

## Mechanism and reaction rate of the Karl-Fischer titration reaction. Part I. Potentiometric measurements

**Citation for published version (APA):**

Verhoef, J. C., & Barendrecht, E. (1976). Mechanism and reaction rate of the Karl-Fischer titration reaction. Part I. Potentiometric measurements. *Journal of Electroanalytical Chemistry*, 71(3), 305-315.  
[https://doi.org/10.1016/S0022-0728\(76\)80017-4](https://doi.org/10.1016/S0022-0728(76)80017-4)

**DOI:**

[10.1016/S0022-0728\(76\)80017-4](https://doi.org/10.1016/S0022-0728(76)80017-4)

**Document status and date:**

Published: 01/01/1976

**Document Version:**

Publisher's PDF, also known as Version of Record (includes final page, issue and volume numbers)

**Please check the document version of this publication:**

- A submitted manuscript is the version of the article upon submission and before peer-review. There can be important differences between the submitted version and the official published version of record. People interested in the research are advised to contact the author for the final version of the publication, or visit the DOI to the publisher's website.
- The final author version and the galley proof are versions of the publication after peer review.
- The final published version features the final layout of the paper including the volume, issue and page numbers.

[Link to publication](#)

**General rights**

Copyright and moral rights for the publications made accessible in the public portal are retained by the authors and/or other copyright owners and it is a condition of accessing publications that users recognise and abide by the legal requirements associated with these rights.

- Users may download and print one copy of any publication from the public portal for the purpose of private study or research.
- You may not further distribute the material or use it for any profit-making activity or commercial gain
- You may freely distribute the URL identifying the publication in the public portal.

If the publication is distributed under the terms of Article 25fa of the Dutch Copyright Act, indicated by the "Taverne" license above, please follow below link for the End User Agreement:

[www.tue.nl/taverne](http://www.tue.nl/taverne)

**Take down policy**

If you believe that this document breaches copyright please contact us at:

[openaccess@tue.nl](mailto:openaccess@tue.nl)

providing details and we will investigate your claim.

## MECHANISM AND REACTION RATE OF THE KARL-FISCHER TITRATION REACTION

### PART I. POTENTIOMETRIC MEASUREMENTS

J.C. VERHOEF

*Laboratory of Analytical Chemistry, Free University, de Boelelaan 1085, Amsterdam  
(The Netherlands)*

E. BARENDRECHT

*Laboratory of Electrochemistry, Technical University, P.O. Box 513, Eindhoven  
(The Netherlands)*

(Received 17th November 1975)

#### ABSTRACT

The reaction rate of the coulometric variant of the Karl-Fischer titration reaction (in which electrolytically generated triiodide is used as oxidant instead of iodine) has been measured in methanol. The reaction is first order in water, sulfur dioxide and triiodide, respectively. For  $\text{pH} < 5$  the reaction rate constant decreases logarithmically with decreasing pH. Addition of pyridine solely influences the pH (by fixing it to a value of about 6) and has no direct influence on the reaction rate. A linear relation exists between the reaction rate constant and the reciprocal value of the iodide concentration, from which we can calculate the individual reaction rates for the oxidation by iodine and triiodide, respectively. While the reaction rate constant for triiodide is relatively small ( $k_3 \approx 350 \text{ l}^2 \text{ mol}^{-2} \text{ s}^{-1}$ ), the reaction rate constant for iodine is much larger ( $k_3 \approx 1.5 \times 10^7 \text{ l}^2 \text{ mol}^{-2} \text{ s}^{-1}$ ).

#### INTRODUCTION

Among the many methods for the determination of water that are available [1] the titrimetric method as introduced by Karl Fischer [2] in 1935 has surpassed all others in simplicity and applicability. Although the titration according to Karl Fischer is used nowadays as a routine determination, one still has not succeeded to unravel completely the reaction mechanism [3–7].

The mechanism that Fischer originally proposed stems from the benzene experiments, for in his publication he assumes that one mole of iodine is equivalent to two moles of water:

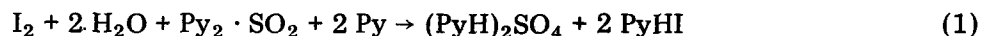

Later investigations by Mitchell and Smith [3] showed that in alcoholic solutions one mole of iodine is equivalent to one mole of water. They proposed the following two-step overall mechanism

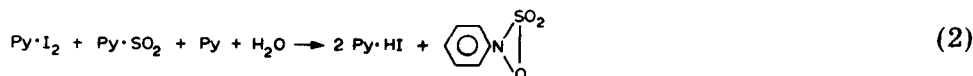

In the second step the pyridine sulfurtrioxide is solvolysed by methanol (that must be present in a very large excess over water, otherwise this too will solvolyse the pyridine sulfurtrioxide).

The vast majority of publications [8–18] on the Karl-Fischer reagent deals with technical problems of handling and keeping the reagent, with various applications, with possible substitutes or alterations of the reagent and with measuring techniques. Little has been published on the mechanism of the reaction. Since the investigations of Mitchell and Smith some authors tried to investigate the possible intermediates and especially the role of pyridine. To our knowledge, no publications so far have considered the role of the pH in the reaction mechanism.

#### THEORY

To measure the reaction rate of the titration reaction it is most convenient to monitor the triiodide concentration. In a buffered solution with a relatively large excess of water, sulfur dioxide and iodide, only the triiodide concentration will vary. If we assume the reaction to be first order in triiodide, the decrease in the triiodide concentration per unit of time is proportional to its instantaneous concentration (concentrations are used instead of activities throughout):

$$dc_{\text{I}_3^-} / dt = -k_1 c_{\text{I}_3^-} \quad (4)$$

So

$$\ln c_{\text{I}_3^-} = \ln c_{\text{I}_3^-}^0 - k_1 t \quad (5)$$

where  $c_{\text{I}_3^-}$ ,  $k_1$  and  $c_{\text{I}_3^-}^0$  are, respectively, the actual triiodide concentration, the pseudo-first order reaction rate constant and the initial triiodide concentration. According to Nernst's law, the potential of an inert electrode in a solution of iodide and triiodide is given by:

$$E = E^{0'} + (RT/2F) \ln(c_{\text{I}_3^-} / (c_{\text{I}^-})^3) + E_j \quad (6)$$

where  $E^{0'}$  is the formal standard redox potential and  $E_j$  the junction potential.

When the iodide concentration is relatively large, one can write instead of (6):

$$E = E^{0''} + (RT/2F) \ln c_{I_3^-} \quad (7)$$

where

$$E^{0''} = E^{0'} + E_j - (3RT/2F) \ln c_{I^-}$$

From (5) and (7) follows:

$$E = E^{0''} + (RT/2F) \ln c_{I_3^-}^0 - (RT/2F) k_1 t \quad (8)$$

A plot of  $E$  vs.  $t$  gives a straight line with a slope

$$(dE/dt) = -(RT/2F) k_1 \quad (9)$$

and an intercept

$$E_{t=0} = E^{0''} + (RT/2F) \ln c_{I_3^-}^0 \quad (10)$$

Cedergren [6] has shown that a platinum electrode can be used successfully as a monitoring electrode for the triiodide concentration, but he has not taken advantage of the logarithmic characteristic of the electrode. This, indeed, makes it possible to obtain directly the reaction rate constant and obviates the tedious way of first making a calibration curve. From (9) it follows that it is not necessary to know the initial triiodide concentration,  $c^0$ .

If the sulfur dioxide concentration is not relatively large with respect to the triiodide concentration, the reaction becomes pseudo-second order (assuming that the reaction is first order both in  $I_3^-$  and  $SO_2$ ). Then:

$$dc_{I_3^-}/dt = -k_2 c_{SO_2} c_{I_3^-} \quad (11)$$

with

$$dc_{I_3^-}/dt = dc_{SO_2}/dt$$

So

$$\ln c_{I_3^-} = \ln(c_{I_3^-}^0/c_{SO_2}^0) + \ln c_{SO_2} + (c_{I_3^-}^0 - c_{SO_2}^0) k_2 t \quad (12)$$

where  $c_{I_3^-}^0$  and  $c_{SO_2}^0$  are the initial triiodide and sulfur dioxide concentrations, respectively.

If  $c_{SO_2}^0 \gg c_{I_3^-}^0$ , then  $c_{SO_2} \approx c_{SO_2}^0$  and (12) simplifies to (5), with  $k_1 = c_{SO_2}^0 k_2$ . Combination of (7) and (12) gives:

$$E = E^{0''} + \frac{RT}{2F} \ln \frac{c_{I_3^-}^0}{c_{SO_2}^0} + \frac{RT}{2F} \ln c_{SO_2} + \frac{RT}{2F} (c_{I_3^-}^0 - c_{SO_2}^0) k_2 t \quad (13)$$

The tangent in any point of the  $E-t$  curve has a slope:

$$dE/dt = -(RT/2F)(c_{\text{SO}_2}^0 - c_{\text{I}_3}^0 + c_{\text{I}_3})k_2 \quad (14)$$

that varies with the triiodide concentration and therefore with time. However, the initial slope has a value

$$(dE/dt)_0 = -(RT/2F)c_{\text{SO}_2}^0 k_2 \quad (15)$$

that is equal to the slope in the first order case, with  $k_1 = c_{\text{SO}_2}^0 k_2$ .

In the case that the water concentration too is small, the reaction is third order (assuming that the reaction is first order in  $\text{H}_2\text{O}$  as well). Then, one can derive, that the initial slope of the  $E-t$  curve has the value

$$(dE/dt)_0 = -(RT/2F)c_{\text{SO}_2}^0 c_{\text{H}_2\text{O}}^0 k_3 \quad (16)$$

This result is the same as (9) with:

$$k_1 = c_{\text{SO}_2}^0 c_{\text{H}_2\text{O}}^0 k_3 \quad (17)$$

At 25°C the factor  $(RT/2F)$  equals 12.85 mV. The (third order) reaction rate constant,  $k_3$ , is obtained by dividing the experimentally found initial slope of the  $E-t$  curve by a factor  $-12.85c_{\text{SO}_2}^0 c_{\text{H}_2\text{O}}^0$ .

## EXPERIMENTAL

### *Apparatus*

The experiments have been carried out at  $25 \pm 0.5^\circ\text{C}$  in a cell as shown in Fig. 1. The main compartment (35 ml) contained the generator electrode (anode) and the indicator electrode. The counter electrode (cathode) compartment (13 ml) and the reference electrode compartment (9 ml) were connected to the main compartment by means of glass frits. The experiments were carried out in a glove box (Mecaplex, model GB 3111/1) with nitrogen continuously pumped through (via silica gel and 3 Å molecular sieve filters). Small amounts of triiodide were generated by a Delta Elektronika current source, model CST 100 (max. capacity 100 mA at 45 V). The potential of the indicator electrode vs. the reference electrode was measured with a PAR, model 135, electrometer and recorded on a Kipp, model BD8, flat bed recorder. The charge through the cell was measured with a Wenking current integrator, model SSI 70. The pH of the solution was measured with a Metrohm combined glass electrode and a Philips digital pH meter, model PW 9408.

### *Reagents*

All methanol used was Baker analytical grade, dried by distillation after refluxing with magnesium. Sodium iodide (Merck or Baker, A.R.) and sodium

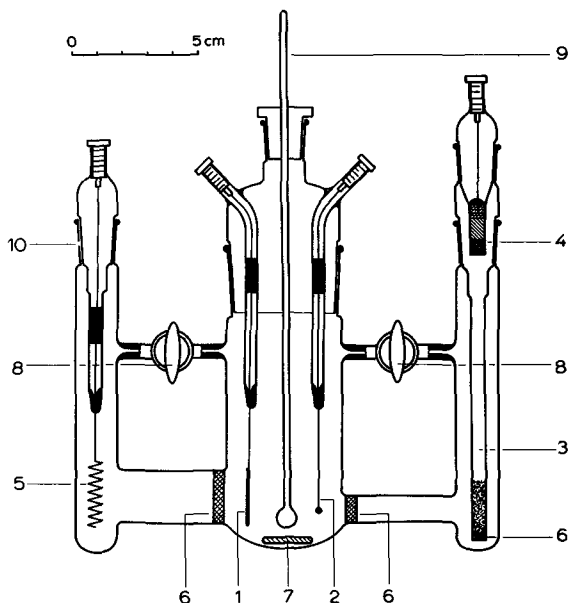

Fig. 1. Coulometric cell. (1) Pt gauze generator electrode, 4 cm<sup>2</sup>; (2) Pt indicator electrode; (3, 4) salt bridge and saturated calomel reference electrode in methanol; (5) Pt wire counter electrode; (6) P3 glass frits; (7) stirring magnet; (8) stop cocks; (9) thermometer; (10) vent.

acetate (Baker, A.R., anhydrous) were dried at ca. 150°C for at least 24 h. Sulfur dioxide (Matheson, anhydrous gas) was used without further purification. Dried pyridine (Merck), tetramethyl ammonium hydroxide (EGA, ca. 3 M solution in methanol) or sodium hydroxide (Baker, A.R.) together with glacial acetic acid (Baker, A.R.), monochloroacetic acid (Baker, A.R.), dichloroacetic acid (Baker), trichloroacetic acid (Baker, A.R.), salicylic acid (Baker, A.R.), hydrogen chloride (Baker, gaseous) or perchloric acid (Baker, A.R.) were used for buffering, also without further purification. As the  $pK_a$  of acetic acid in methanol is 9.7 [21], sodium acetate can be used instead of sodium hydroxide at lower pH values in order to keep the water concentration small.

Typical concentrations of the reagents used are: iodide 0.5 M, sulfur dioxide 10–100 mM, water 30–100 mM, buffer 0.1 M + 0.1 M conjugated acid–base couple.

### Procedure

Before each experiment the cell was overfilled with a few milliliters of the buffered sodium iodide solution. After sulfur dioxide was added, the pH was readjusted, if necessary, to the desired value with perchloric acid, sodium acetate, etc. The excess cell content was used for a preliminary water determination by the classical Karl-Fischer method. The result served to calculate

the amount of water to be added for the adjustment of a desired water concentration. Then, a generating current of approximately 100 mA was allowed to flow through the cell until the potential of the indicator electrode reached a value of about 100 mV vs. SCE. After each experiment 10 ml of the cell content was used for an accurate determination of the final water concentration and 5 to 10 ml was used for an iodometric determination of the final sulfur dioxide concentration (addition of a small excess of an aqueous iodine solution and a subsequent back titration with sodium thiosulfate). Then, the pH was checked: a shift less than 0.05 pH unit was considered as acceptable. In order to obtain the actual concentrations at the beginning of each experiment, the current integrator readings were used to correct for consumption of sulfur dioxide and water during the experiments.

## RESULTS AND DISCUSSION

The response time of the indicator electrode and the time of mixing of the triiodide formed determine the maximum possible rate of potential decrease. First order reaction rates to approximately  $2 \text{ s}^{-1}$  (i.e. about 25 mV potential decrease per second) were still reliable; at higher first order reaction rates too low values were always found. Further, potential decrease rates less than  $0.1 \text{ mV s}^{-1}$  were not reliable because of drift of the system and, moreover, made the measurements very time consuming. A potential change of more than 50 mV was usually obtained. A typical potential–time curve is shown in Fig. 2. At time  $t_0$  the current source was switched on and at  $t_1$  switched off. As can be seen, the descending part of the  $E-t$  curve is completely straight. Only when one of the concentrations of the constituents of the reagent was very small (or the buffering was insufficient) the linearity of the  $E-t$  curve was poor, but the initial slope was always well measurable.

The order of the reaction with respect to sulfur dioxide and water has been investigated by changing only one concentration and keeping all other parameters constant. The results are shown in Fig. 3 from which it appears that the

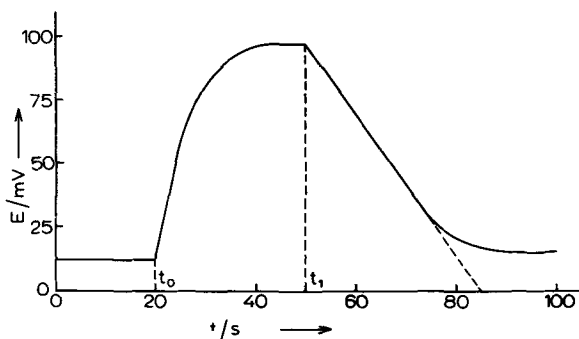

Fig. 2. Typical potential–time curve.  $c_{\text{H}_2\text{O}} = 29 \text{ mM}$ ,  $c_{\text{SO}_2} = 10 \text{ mM}$ ,  $c_{\text{I}^-} = 0.5 \text{ M}$ ,  $\text{pH} = 5.0$  (dichloroacetic acid buffer).

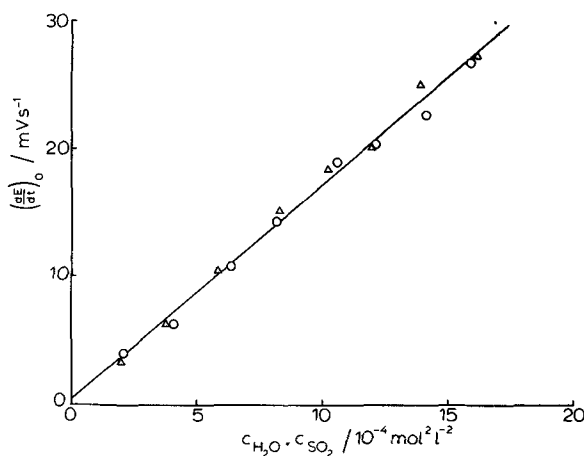

Fig. 3. Initial rate of potential change as a function of change in concentration at  $\text{pH} = 6.0$  and  $c_{\Gamma} = 0.5 \text{ M}$ . (O) Variation of  $c_{\text{H}_2\text{O}}$ , with  $c_{\text{SO}_2} = 10 \text{ mM} \pm 10\%$ ; ( $\Delta$ ) variation of  $c_{\text{SO}_2}$ , with  $c_{\text{H}_2\text{O}} = 50 \text{ mM} \pm 10\%$ .

reaction is first order in both sulfur dioxide and water. To investigate the pH dependence of the reaction, the pH was varied over a wide range, from  $\text{pH} = 2$  to  $\text{pH} = 11$  (Fig. 4, a). The points in this Figure are the mean values of several measurements with different sulfur dioxide and water concentrations at a certain pH value.

In acid solutions up to ca.  $\text{pH} = 5$  the logarithm of the reaction rate constant increases linearly with the pH. In the range from  $\text{pH} = 5.5$  to  $\text{pH} = 8$  the reaction rate has a constant value:  $\log k_3 = 3.12$ . This value agrees well with the value found by Cedergren [6]:  $k_3 = 1200 \pm 200$ , i.e.  $\log k_3 = 3.08 \pm 0.08$ . It appeared that addition of pyridine to a buffered solution (and readjustment of the pH, if necessary) has no influence on the reaction rate (Table 1). A solu-

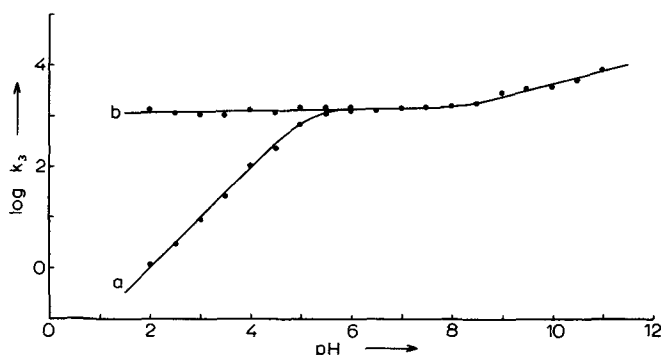

Fig. 4. Reaction rate constant as a function of the pH. (a) Measured reaction rate; (b) recalculated for monomethyl sulfite.



TABLE 1

Values of  $\log k_3$  at different pH values and different pyridine concentrations

$c_{Py}/mM$	$\log k_3$ at		
	pH = 5.0	pH = 6.0	pH = 7.0
0	2.75	3.15	3.16
10	2.75	3.12	3.18
30	2.78	3.13	3.14
100	2.83	3.17	3.15

tion that is buffered with pyridine (to a value of  $pH \approx 6$ ) gives the same results as a solution that is buffered with another buffer reagent, e.g. dichloroacetate or salicylate. This makes it clear, that in solutions where the pyridine concentration is in excess, because of the good buffering capacities of pyridine, the reaction rate does not vary with increasing pyridine concentrations, since a plateau is already reached in the reaction rate constant—pH curve [6,7].

At  $pH = 8.5$  the reaction rate increases again with pH, but to a much lesser extent than in the  $pH$  range  $\leq 5$ . Possibly, the formation of iodonium hydroxide or iodonium methoxide that occurs at this pH value [19] is the cause of this effect.

The shape of the  $\log k_3$  vs. pH curve suggests that not sulfur dioxide itself, but a sulfurous base is oxidized. Although sulfites and bisulfites are practically insoluble in methanol, a sulfur dioxide solution can be titrated with a methanolic tetramethylammonium hydroxide solution without the formation of a precipitate. Recrystallization of the  $(CH_3)_4N^+SO_3CH_3^-$  formed, however, renders it insoluble. Only the pyridine—sulfur dioxide adduct is soluble, but this is probably not a salt. From the titration curve one can calculate an apparent dissociation constant for the reaction

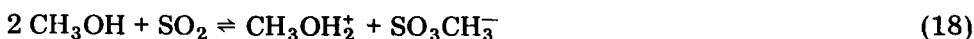

$$K_a = c_{CH_3OH_2^+} c_{SO_3CH_3^-} / c_{SO_2}$$

We found for  $pK_a$  a value of  $6.02 \pm 0.02$ , independent of the water concentration, so that the formation of bisulfite according to



$$K'_a = c_{CH_3OH_2^+} c_{HSO_3^-} / c_{SO_2} c_{H_2O}$$

is unlikely. In a 0.5 M sodium iodide solution we found a larger value for  $K$ :  $pK_a = 5.10$ .

The titration curve shows no second inflection point, so that a methanolic

sulfur dioxide solution can be considered as to contain a moderately weak monobasic acid. If the analytical sulfur dioxide concentration (i.e. the total concentration of sulfurous products as it is determined by iodometry) is  $\bar{c}_{\text{SO}_2}$ , then one can easily derive that

$$\bar{c}_{\text{SO}_2} = c_{\text{CH}_3\text{SO}_3^-} (1 + c_{\text{H}^+}/K_a) \quad (20)$$

in which  $c_{\text{H}^+}$  is the concentration of the solvated proton.

The reaction rate

$$v = dc_{\text{I}_3^-}/dt = k_3 c_{\text{I}_3^-} c_{\text{H}_2\text{O}} \bar{c}_{\text{SO}_2} \quad (21)$$

can now be written as:

$$v = k'_3 c_{\text{I}_3^-} c_{\text{H}_2\text{O}} c_{\text{CH}_3\text{SO}_3^-} \quad (22)$$

where

$$k'_3 = k_3 (1 + c_{\text{H}^+}/K_a) \quad (23)$$

If we may interchange the activity and the concentration of the solvated proton, then at  $c_{\text{H}^+} \gg 10^{-\text{p}K_a}$ :

$$\log k'_3 = \log k_3 - \text{pH} + \text{p}K_a \quad (24)$$

while at  $c_{\text{H}^+} \ll 10^{-\text{p}K_a}$ :

$$\log k'_3 = \log k_3 \quad (25)$$

Recalculation of the reaction rate for the monomethyl sulfite ion with (23), (24) or (25) shows, that  $k'_3$  is independent of the pH (Fig. 4, b).

We have studied the effect of change of the iodide concentration. Triiodide is in equilibrium with iodine and iodide:

$$K = c_{\text{I}_3^-}/c_{\text{I}_2} c_{\text{I}^-} \quad (26)$$

If both triiodide and iodine oxidize the sulfurous base with reaction rates  $k_{\text{I}_3^-}$  and  $k_{\text{I}_2}$ , then one can easily derive, that

$$k_3 = (k_{\text{I}_3^-} K c_{\text{I}^-} + k_{\text{I}_2}) / (1 + K c_{\text{I}^-}) \quad (27)$$

If the iodide concentrations are chosen so that

$$K c_{\text{I}^-} \gg 1$$

we may simplify (27) to

$$k_3 = k_{\text{I}_3^-} + k_{\text{I}_2}/K c_{\text{I}^-} \quad (28)$$

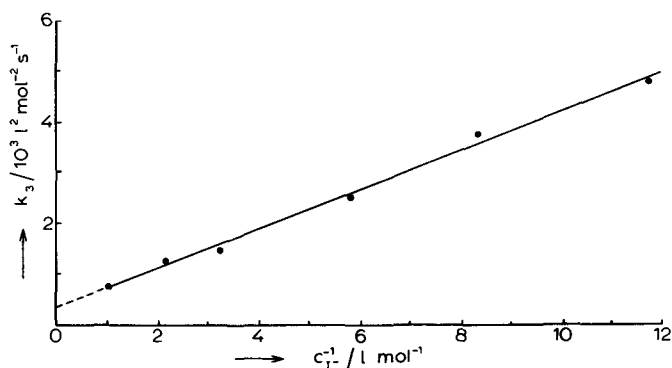

Fig. 5. Reaction rate constant as a function of the iodide concentration at pH = 6.5.

A plot of  $k_3$  vs.  $1/c_{I^-}$  gives a straight line with intercept  $k_{I_3^-}$  and slope  $k_{I_2}/K$  (Fig. 5).

We find

$$k_{I_3^-} = (3.46 \pm 0.93) \times 10^2 \text{ and } k_{I_2}/K = (3.84 \pm 0.14) \times 10^2$$

Triiodide is very stable in methanol and therefore the value of  $K$  is very large. A value of  $K = 2.3 \times 10^4$  is given in the literature [19] (respectively [20]  $\geq 4 \times 10^4$ ); with this value we find  $k_{I_2} = 8.8 \times 10^6$ .

The large difference in reaction rate of iodine and triiodide is remarkable. We could think of a reaction intermediate

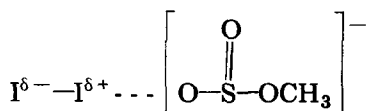

or even

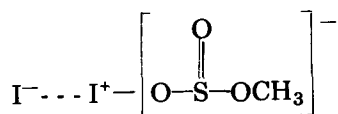

that would be much easier formed with iodine than with triiodide. This intermediate then is hydrolysed by water to form hydroiodic acid and monomethylsulfate. If it is also very slowly solvolysed by methanol, this would be a possible explanation for the slow decrease in titer of a Karl-Fischer reagent.

## CONCLUSION

Since the publication of the monography by Mitchell and Smith [3], all authors have more or less accepted a mechanism for the Karl-Fischer titration reaction in which pyridine plays an important role. From our experiments,

however, it appears that pyridine solely acts as a buffer and that at a fixed pH addition of pyridine has no influence on the reaction rate.

The species oxidized is not sulfur dioxide, but a sulfurous base, the mono-methyl sulfite ion. At pH values larger than about 6 practically all sulfur dioxide is converted into this base, so that the reaction rate has a maximum value. This reaction rate is composed of two contributions: oxidation by the slow reacting triiodide that is present in very large excess and oxidation by the fast reacting iodine of which very little is present. Since at low iodide concentrations the iodine concentration is larger, the usual analytical technique (in which the content of one vessel is used for several subsequent titrations) is, from the view-point of performing a rapid titration, less favorable.

#### REFERENCES

- 1 C. Harris, *Talanta*, 19 (1972) 1523.
- 2 K. Fischer, *Angew. Chem.*, 48 (1935) 394.
- 3 J. Mitchell, Jr. and D.M. Smith, *Aquametry*, Interscience, New York, 1948. Ch. III.
- 4 E. Eberius, *Wasserbestimmung mit Karl-Fischer Lösung*, Verlag Chemie, Weinheim, 2e Aufl., 1958, pp. 36—49.
- 5 E. Bonauguri and G. Seniga, *Z. Anal. Chem.*, 144 (1955) 161.
- 6 A. Cedergren, *Talanta*, 21 (1974) 265.
- 7 E. Barendrecht and J.C. Verhoef, *J. Electroanal. Chem.*, 59 (1975) 221.
- 8 A.S. Meyer, Jr. and C.M. Boyd, *Anal. Chem.*, 31 (1959) 215.
- 9 M.R. Lindbeck and H. Freund, *Anal. Chem.*, 37 (1965) 1647.
- 10 R. Karlsson and K.J. Karrman, *Talanta*, 18 (1971) 459.
- 11 T.H. Beasley, Sr., H.W. Ziegler, R.L. Charles and P. King, *Anal. Chem.*, 44 (1972) 183.
- 12 A. Cedergren, *Talanta*, 21 (1974) 553.
- 13 E. Barendrecht and J.G.F. Doornekamp, *Z. Anal. Chem.*, 186 (1962) 176.
- 14 P.A. Shaffer, Jr., A. Briglio, Jr. and J.A. Brockman, Jr., *Anal. Chem.*, 20 (1948) 1008.
- 15 E.D. Peters and J.L. Jungnickel, *Anal. Chem.*, 27 (1955) 450.
- 16 R.F. Swensen and D.A. Keyworth, *Anal. Chem.*, 35 (1963) 863.
- 17 F.B. Sherman, M.P. Zabokritskii and V.A. Klimova, *J. Anal. Chem. USSR*, 28 (1974) 1450.
- 18 R. Belcher and T.S. West, *J. Chem. Soc.*, (1953) 1772.
- 19 J.C. Verhoef, W.H. Voogt and E. Barendrecht, to be published.
- 20 S. Lormeau and M.H. Mannebach, *Bull. Soc. Chim. France*, (1966) 2576.
- 21 B. Trémillon, *La Chimie en Solvants Non-Aqueux*, Presses Universitaires de France, Paris, 1971, p. 78.