

## Research Article

# Wind Tunnel Tests on Aerodynamic Characteristics of Ice-Coated 4-Bundled Conductors

Li Xin-min,<sup>1</sup> Nie Xiao-chun,<sup>2</sup> Zhu Yong-kun,<sup>3</sup> You Yi,<sup>2</sup> and Yan Zhi-tao<sup>4</sup>

<sup>1</sup>China Electric Power Research Institute, Haidian District, Beijing 100192, China

<sup>2</sup>School of Civil Engineering, Chongqing University, Shapingba District, Chongqing 400030, China

<sup>3</sup>State Grid East Inner Mongolia Electric Power Company Limited, Hohhot 010020, China

<sup>4</sup>School of Civil Engineering and Architecture, Chongqing University of Science and Technology, Shapingba District, Chongqing 401331, China

Correspondence should be addressed to Yan Zhi-tao; [yanzhitao@cqu.edu.cn](mailto:yanzhitao@cqu.edu.cn)

Received 20 February 2017; Revised 4 June 2017; Accepted 9 July 2017; Published 4 October 2017

Academic Editor: Yuri Vladimirovich Mikhlin

Copyright © 2017 Li Xin-min et al. This is an open access article distributed under the Creative Commons Attribution License, which permits unrestricted use, distribution, and reproduction in any medium, provided the original work is properly cited.

Wind tunnel tests were carried out to obtain the static aerodynamic characteristics of crescent iced 4-bundled conductors with different ice thicknesses, initial ice accretion angles, bundle spaces, and wind attack angles. The test models were made of the actual conductors and have a real rough surface. Test results show that the influence of wake interference on the drag coefficients of leeward subconductors is obvious. The interference angle range is larger than  $20^\circ$  and the drag coefficient curves of leeward subconductors have a sudden decrease phenomenon at some certain wind attack angles. The absolute value of the lift and moment coefficient increases with the increase of the ice thickness. In addition, the galloping of the iced subconductor may occur at the angle of wind attack near  $\pm 20^\circ$  and the wake increases the moment coefficient. The variation of initial ice accretion angle has a significant influence on the aerodynamic coefficients. The aerodynamic coefficient curves exhibit a “moving” phenomenon at different initial ice accretion angles. The bundle spaces have a great influence on the moment coefficient of leeward thin ice-coated conductors. With the increase of ice thickness, the bundle spaces generally have little influence on the aerodynamic coefficients.

## 1. Introduction

China is a mountainous country. The mountain area accounts for more than 60% of the land area. The mountainous southwestern region is rich in hydropower resources and it is also the main power generation area of the West-East Electricity Transmission Project. Most of the transmission lines will cross valleys, rivers, and micrometeorological areas in mountainous southwestern regions, where the conductors are easily ice-coated in winter. Under certain conditions, the ice-coated conductor will produce large amplitude and low frequency self-excited vibration, which is called galloping [1, 2]. Galloping may cause transmission lines' collision, fittings failure, line trip and power outage, or even line breaking, tower failure, and other great dangers [3]. In 2008, the biggest snow and ice disaster in this century hit the southern region of China, which led to transmission lines icing on a large scale and seriously affected the normal operation of the

power system. Since the aerodynamic coefficients of ice-coated conductors are the basis for the study of galloping, it is necessary to investigate the aerodynamic characteristics of the ice-coated conductors in ultrahigh voltage transmission lines.

There are lots of researches about the aerodynamic characteristics of ice-coated conductors. As early as 1932, Den Hartog [4] proposed the vertical galloping mechanism of ice-coated conductors. Nigol et al. [5–7] proposed the torsional motion mechanism and the protective measures of galloping by the experimental study of the ice-coated conductors. Gurung et al. [8] and van Dyke and Laneville [9] carried out a full-scale test to obtain the aerodynamic characteristics of the iced conductor. However, investigation on full-scale test line is limited because of the low efficiency, high cost and difficulty to record test data accurately. Therefore, the wind tunnel test became the most common method to study the aerodynamic characteristics of the conductor. Rawlins [10]

and Chabart and Lilien [11] measured the aerodynamic characteristics of single conductors in wind tunnel test. However, the study by Zhang et al. [12] showed that galloping takes place more frequently on a bundle conductor transmission line than on a single one because the cross-sectional shape of the ice accreted on a bundle conductor tends to be non-circular due to its larger torsional stiffness. Zhou et al. [13] carried out a wind tunnel test to obtain the aerodynamic coefficients of the iced eight bundle conductor with crescent shape. It is concluded that the air flow interference effect around sub-conductors is obvious. The similar conclusions have been obtained in the study of Hu et al. [14] and Diana et al. [15]. However, these studies are lack of specific conclusions about the effects of wake interference on aerodynamic characteristics of iced conductor. The aerodynamic characteristics of crescent and D-shape conductors have been studied in wind tunnel by Stumpf and Ng [16], Chadha and Jaster [17] as well. Lou et al. [18] carried out a wind tunnel test to investigate the influence of the initial ice accretion angle on the aerodynamic characteristics of D-shape 2-bundled and 6-bundled conductors. It also gave the Den Hartog coefficients of D-shape bundled conductors with various initial ice accretion angles. However, the experimental data of the influence of the initial ice accretion angle on the aerodynamic force of the crescent iced 4-bundled conductor is still lacking.

It is worth noting that most of the scholars currently use smooth surface conductor models in experiments. In this paper, the sectional models were made of the actual conductors and have a real rough surface. In addition, research on the influence on the bundle space and the initial ice accretion angle of the crescent iced 4-bundled conductors is still rare. Therefore, tests were carried out to obtain the variation laws of static aerodynamic characteristics of crescent iced 4-bundled conductors with different ice thicknesses, initial ice accretion angles, bundle spaces, and wind attack angles in the wind tunnel. The obtained results may provide the fundamental data for the development of antigalloping techniques of ice-coated 4-bundled conductors.

## 2. Experiment Design

The wind tunnel tests were carried out in  $1.4\text{ m} \times 1.4\text{ m}$  low-speed wind tunnel at the China Aerodynamics Research and Development Center (CARD C). The maximum wind velocity is  $60\text{ m/s}$ . The test model in wind tunnel is shown in Figure 1(a). The experimental setup is shown in Figure 1(c), where two balances are applied to measure the aerodynamic forces. Both ends of the conductor are fixed on a balance by the connector, respectively. Compared with the way of measuring balance set at one end of the conductor, this method can eliminate the measurement error from model vibration, and it is also more suitable for the high velocity tests. The aerodynamic forces of all subconductors are measured in turn by changing the installation position of the balance.

The actual transmission conductors were chosen for the test model, whose type is LGJ400/35 ( $d = 26.8\text{ mm}$ ), and the model ratio is 1:1, as shown in Figure 1(b). Compared to most conventional models in previous studies, the paper's



(a) Iced 4-bundled conductors

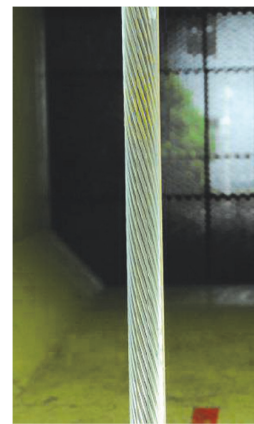

(b) Real conductor

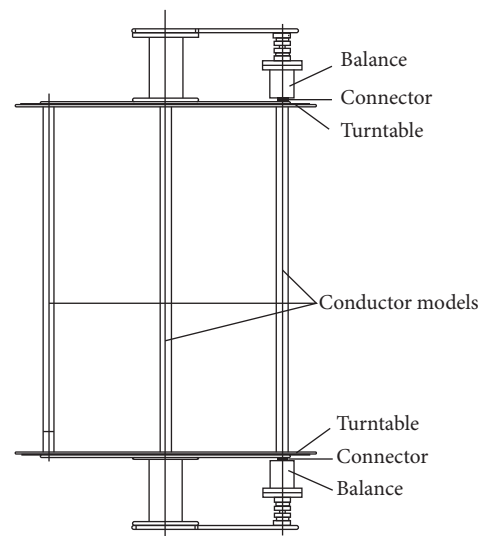

(c) The experimental setup

FIGURE 1: Model in the wind tunnel.

model is more approximate to the real situation. The crescent iced model is fixedly connected to the surface of the conductor model. The ice thicknesses ( $H$ ) of models are  $10\text{ mm}$ ,

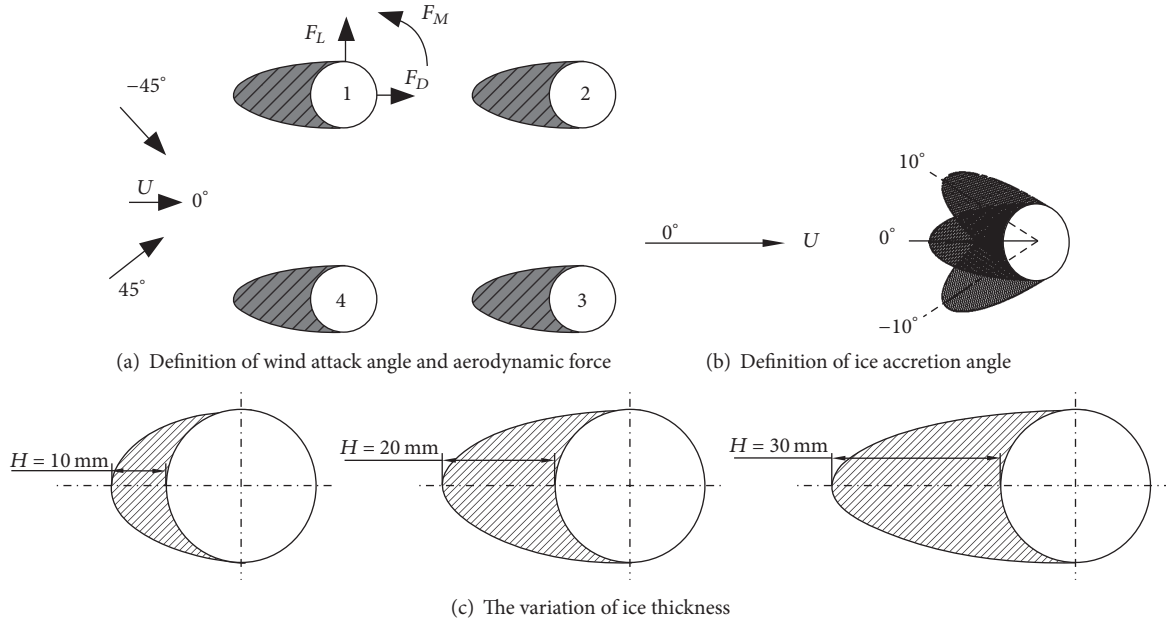

FIGURE 2: Definition of wind attack angle and aerodynamic force and ice accretion angle.

20 mm, and 30 mm, respectively, as shown in Figure 2(c), and the bundle spaces are 485 mm, 450 mm, and 400 mm, respectively. Since the initial ice accretion angle existed in the actual icing conductor, the initial ice accretion angles of  $0^\circ$ ,  $-10^\circ$ , and  $+10^\circ$  are discussed in this experiment, which are shown in Figure 2(b). Considering that the actual variation of the inflow direction will not be too large, the aerodynamic characteristics were only measured at the range of wind attack angle from  $-45^\circ$  to  $45^\circ$  with an interval of  $5^\circ$ . The definition of wind attack angle and aerodynamic force of iced conductors is shown in Figure 2(a). The wind attack angle is changed by rotating the upper and the lower turntable in wind tunnel tests.

The aerodynamic characteristic parameters of the ice-coated conductor include drag coefficient, lift coefficient, and torsional coefficient. The dimensionless characteristic parameters of the ice-coated conductor are defined as follows:

$$\begin{aligned} C_D &= \frac{F_D}{(1/2\rho V^2 Ld)}, \\ C_L &= \frac{F_L}{(1/2\rho V^2 Ld)}, \\ C_M &= \frac{M_Z}{(1/2\rho V^2 Ld^2)}, \end{aligned} \quad (1)$$

where  $F_D$ ,  $F_L$ , and  $M_Z$  are the drag force, the lift force, and the torsional moment, respectively;  $C_D$ ,  $C_L$ , and  $C_M$  are the drag coefficient, the lift coefficient, and the moment coefficient, respectively;  $L$  is the models' reference length ( $L = 1400$  mm);  $d$  is the diameter of naked conductor;  $V$  is wind velocity ( $V = 20$  m/s); and  $\rho$  is the air density.

### 3. Test Results

#### 3.1. Influence of Ice Thickness

**3.1.1. Drag Coefficient.** The variations of subconductors' aerodynamic coefficients with different ice thicknesses and wind attack angles are shown in Figures 3–6 under the condition of the initial ice accretion angle of  $0^\circ$  and the bundle space of 485 mm. Figure 3 shows that the drag coefficient of the windward subconductors 1 and 4 is substantially symmetrical at the range of wind attack angle from  $-45^\circ$  to  $45^\circ$ . Meanwhile, the drag coefficient of leeward subconductors 2 and 3 is substantially symmetrical as well. This confirms the repeatability and accuracy of the tests. In addition, from the comparison of the measured drag coefficient of subconductor 1 with the results from [19], it can be seen that the two results are in good agreement at the wind attack angle of  $0^\circ$ . As also can be seen from Figure 3(a), the drag coefficient of subconductor 1 at the attack angle of  $-45^\circ$  is 1.80, which is close to that of [20]. The error between them is mainly due to the discrepancy of wind velocity ( $V = 10$  m/s in [20] while  $V = 20$  m/s in this article). This shows that the measured results are accurate and feasible.

Figure 3 shows that the windward conductor has an obvious wake interference on the leeward conductor, especially when the ice thickness is relatively thin ( $H = 10$  mm). The curves of drag coefficient have a sudden decrease phenomenon at some certain wind attack angles. Subconductors 2 and 3 are affected by the wake of subconductors 1 and 4 at the angle of wind attack near  $0^\circ$ , respectively, and the drag coefficient decreases by more than 0.5. Moreover, subconductors 2 and 3 are affected by the wake of subconductors 4 and 1 at the angle of wind attack near  $45^\circ$  and  $-45^\circ$ , respectively, and the drag coefficient also significantly reduced. In both cases, the ratios of the distance between the windward and leeward conductors to the diameter of the ice-coated conductor

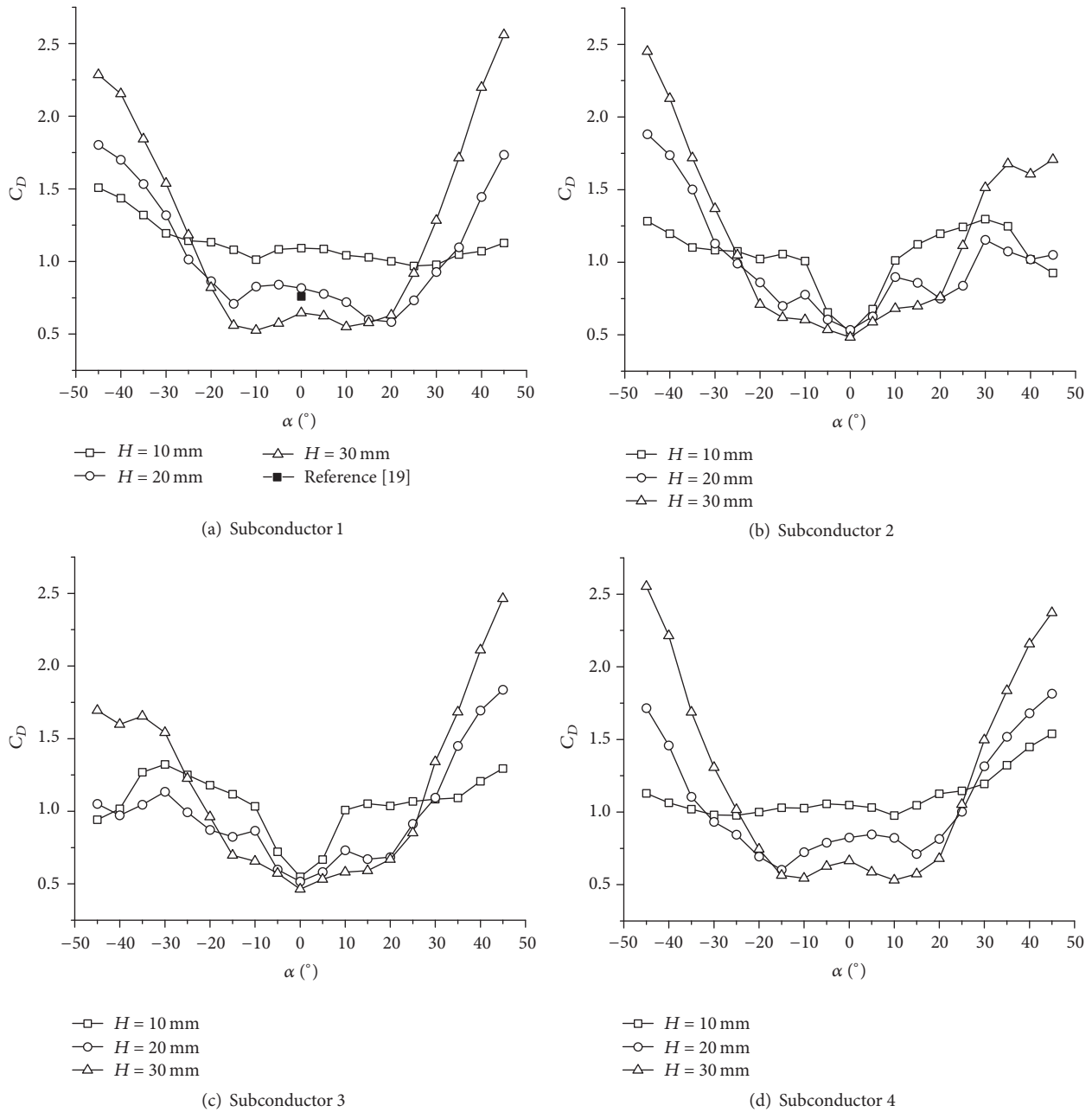

FIGURE 3: Aerodynamic characteristics of bundled conductors with respect to wind attack angle (space: 485 mm).

( $H = 10\text{ mm}$ ) reach 13.2 and 18.6, respectively. This shows the interference distance is relatively large and the interference angle range is larger than  $20^\circ$ .

When the ice thickness increases to 20 mm or 30 mm, the sudden decrease phenomenon of drag coefficient on subconductors 2 and 3 weakens at the angle of attack of  $0^\circ$ . This is mainly because the outline of the conductor is closer to the streamlined body when the ice thickness of the conductor is thicker. The effect of wake interference on aerodynamic characteristics of the ice-coated conductor with streamlined body is smaller than that of the conductor with blunt body. When the wind attack angle is  $-45^\circ$  or  $+45^\circ$ , the streamlined

body has been converted to a similar blunt body, which significantly enhances the interference effect on the leeward conductor. The drag coefficient curves of subconductors 2 and 3 also vary significantly. Due to the variation of wind attack angle, the outlines of the windward conductors vary with the direction of inflow. This also indicates that the windward conductor's outlines play an important role in wake interference on the leeward conductors.

**3.1.2. Lift Coefficient.** Figure 4 shows the curves of the lift coefficient varying with the wind attack angles under different ice thicknesses.

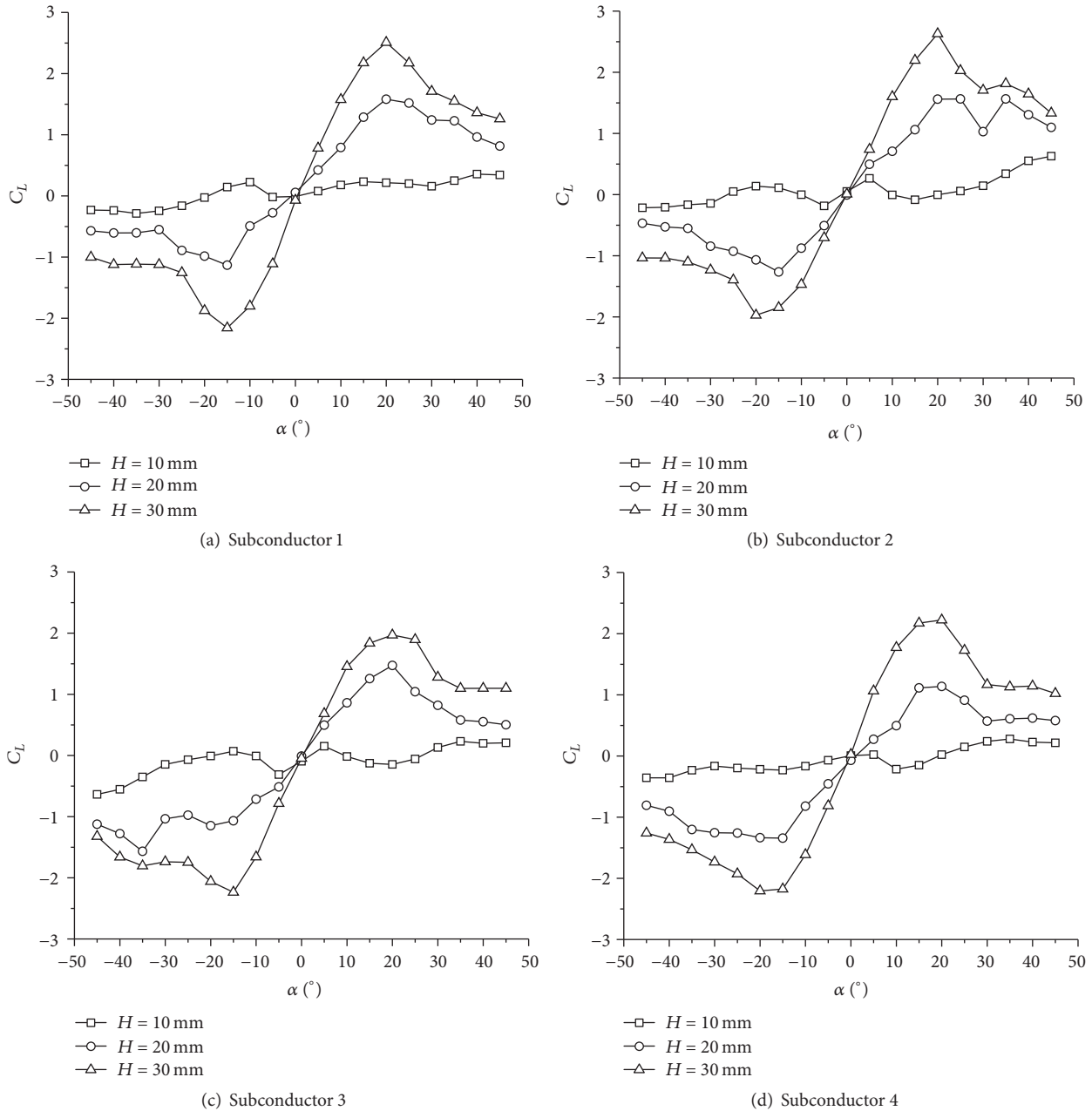

FIGURE 4: Aerodynamic characteristics of subconductors with respect to wind attack angle (space: 485 mm).

It can be seen that the lift coefficients of subconductors are substantially antisymmetric at the range of wind attack angle from  $-45^\circ$  to  $+45^\circ$ . Figure 4 also indicates that the wake interference has a little effect on the lift coefficient of subconductors 2 and 3.

The absolute value of the lift coefficient increases with the increase of the ice thickness in the range of wind attack angles, especially at the angle of wind attack near  $\pm 20^\circ$ . The absolute value of the lift coefficient increases rapidly with the increase of the ice thickness and forms a sudden peak phenomenon at these two angles. This phenomenon is similar to the wing stall, which is a kind of flow separation phenomenon. When the ice thickness is relatively thin, the outline of the

conductor is close to the bluff body, and the flow separation phenomenon is not obvious.

**3.1.3. Moment Coefficient.** Figure 5 shows the curves of the moment coefficient varying with the wind attack angles under different ice thicknesses.

It can be seen from Figure 5 that the moment coefficients of the subconductor are also antisymmetric at the range of attack angle, the same as the lift coefficients varying with the wind attack angles. The ice thickness has a great influence on the moment coefficient of the subconductor, and the absolute value of the moment coefficient increases with the increase of ice thickness. The increasing trend is more obvious

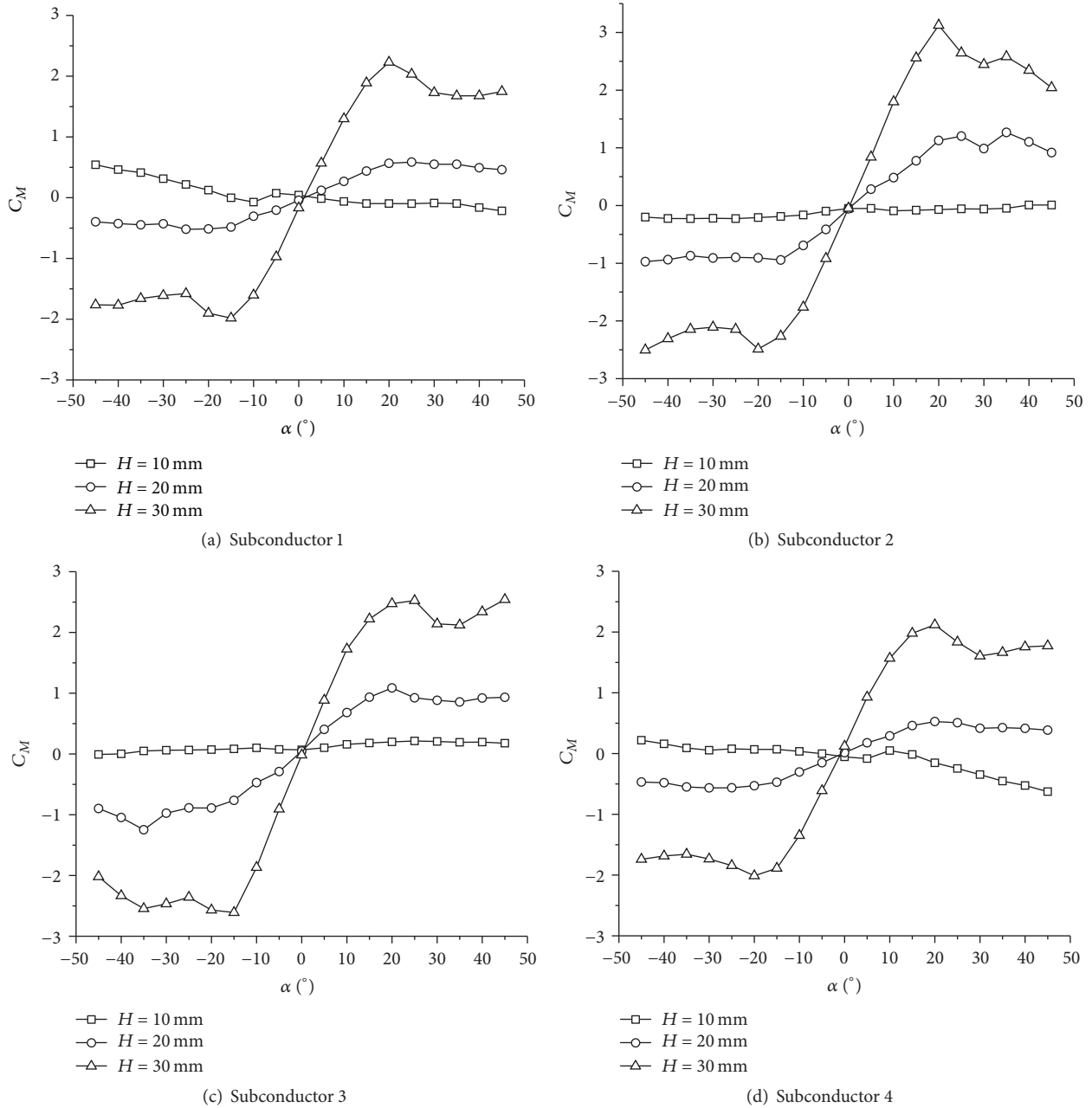

FIGURE 5: Aerodynamic characteristics of bundle conductors with respect to wind attack angle (space: 485 mm).

with thicker ice. The absolute value of moment coefficient of subconductors 2 and 3 is significantly increased at the angle of wind attack near  $+20^\circ$  and  $-20^\circ$ . When the ice is thicker, the absolute value of subconductors 2 and 3 is often larger than that of subconductors 1 and 4, respectively, which indicates that the wake increases the moment coefficient.

**3.1.4. Stability Analysis Based on the Coefficient of Den-Hartog.** The above results show that although the variation laws of aerodynamic coefficients of subconductors with attack angle are basically the same at different ice thicknesses, the measured values are obviously different. In this paper, the

Den-Hartog criterion is performed to estimate the possibility of galloping. Aerodynamic damping less than zero is the necessary condition of instability to gallop; the formula for the criterion is as follows:

$$\text{Den} = \frac{\partial C_L}{\partial \alpha} + C_D < 0, \quad (2)$$

where Den is the coefficient of Den-Hartog;  $C_L$  is the lift coefficient;  $C_D$  is the drag coefficient;  $\alpha$  is the wind attack angle. Figure 6 shows the curves of the Den-Hartog criterion varying with the wind attack angles under different ice thicknesses.

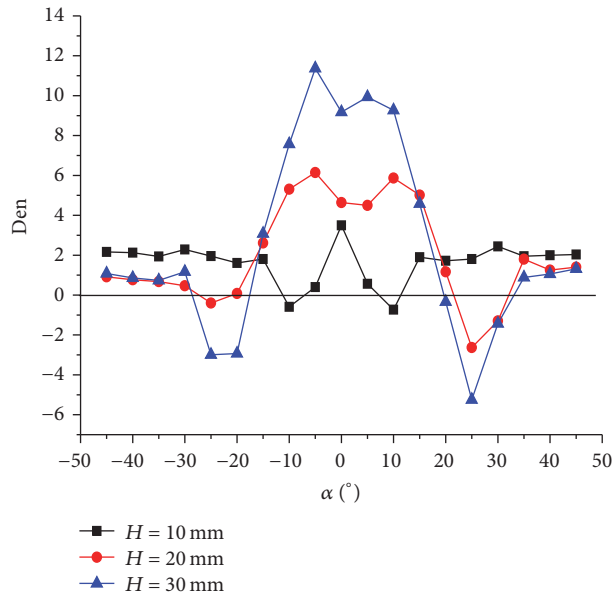

FIGURE 6: Den-Hartog coefficient of conductors varying with ice thickness.

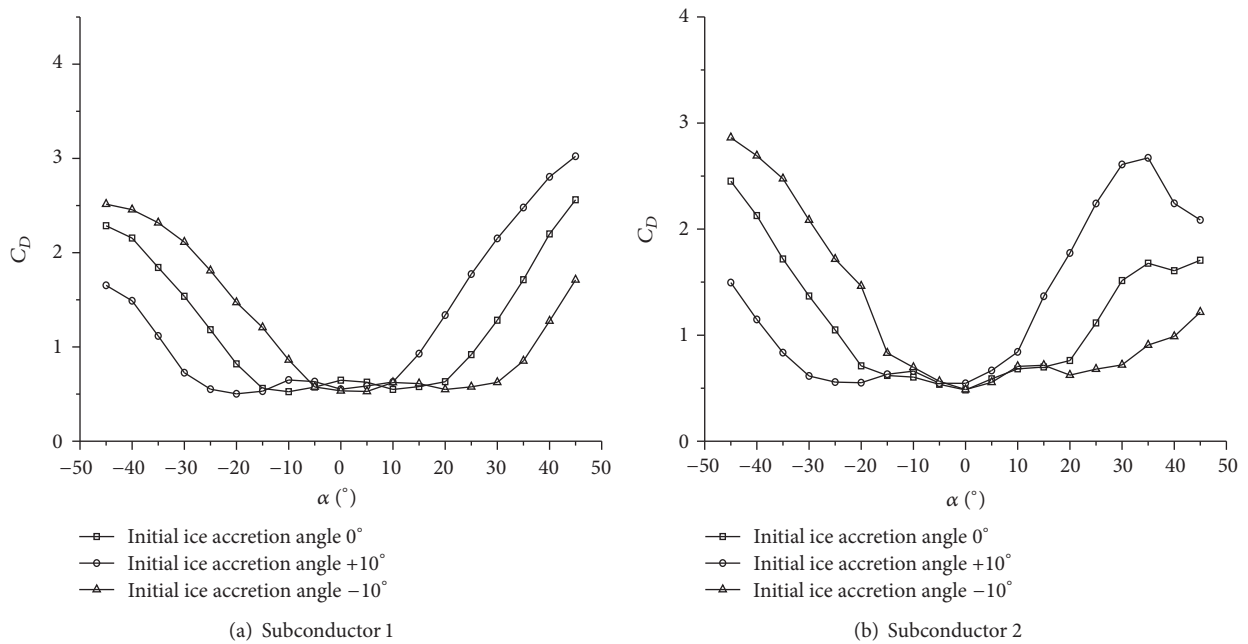

FIGURE 7: Effect of initial ice accretion angle on  $C_D$  (thickness: 30 mm, space: 485 mm).

It can be seen from Figure 6 that the absolute value of the Den-Hartog coefficient of 4-bundled conductors basically increases with the increase of ice thickness. Compared with thin iced conductors, the possibility of galloping of heavy iced conductors is greater, especially in the range of  $-20^\circ \sim -30^\circ$  and  $20^\circ \sim 30^\circ$  of wind attack angle, and the possible galloping regions are similar to those in [18]. Thus, the galloping problem of heavy iced conductors under high wind velocity is worth more attention.

**3.2. Influence of Initial Ice Accretion Angle.** The aerodynamic coefficient curves of subconductors 1 and 2 varying with the wind attack angles under different initial ice accretion angles are shown in Figures 7–9.

It can be seen from Figure 7 that the change of initial ice accretion angle has a significant influence on the drag coefficient. Take the heavy ice-coated conductor as an example; theoretically, the initial ice accretion angle is  $+10^\circ$  or  $-10^\circ$  corresponding to an increase or decrease of the wind

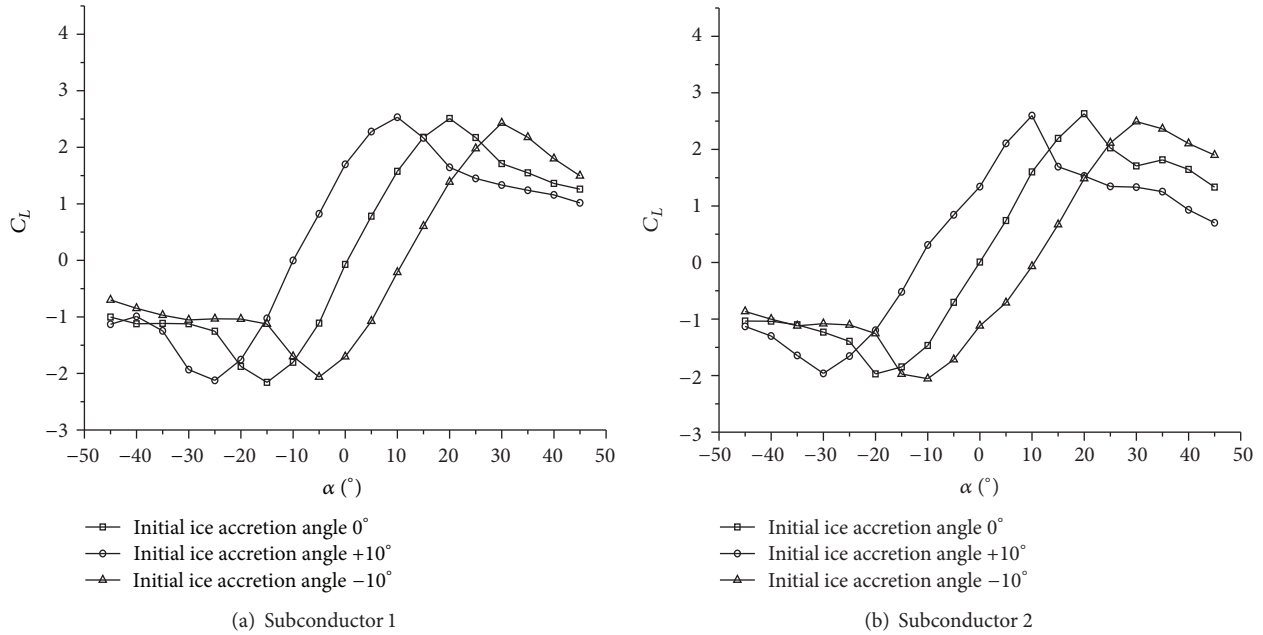

FIGURE 8: Effect of initial ice accretion angle on  $C_L$  (thickness: 30 mm, space: 485 mm).

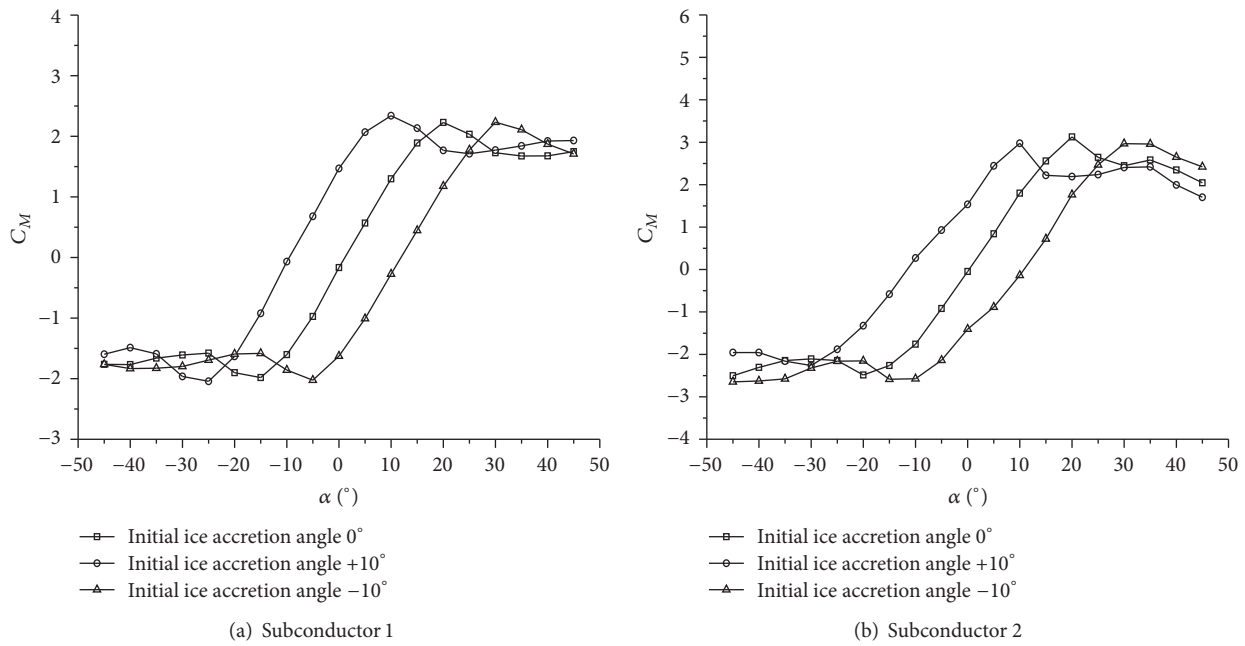

FIGURE 9: Effect of initial ice accretion angle on  $C_M$  (thickness: 30 mm, space: 485 mm).

attack angle by  $10^\circ$ . This means that the drag coefficient curve should appear to be “moving” accordingly. However, this is only suitable for windward subconductors 1 and 4. For leeward subconductors 2 and 3, the interaction between the conductors is complicated due to the influence of wake interference, so “moving” is uneven, especially at the angle of wind attack near  $35^\circ$ .

Figures 8 and 9 show that the slopes of the conductor’s lift and moment coefficient curves are relatively large in a small range of wind attack angle (absolute value within  $20^\circ$ ). In this range, the lift and moment coefficient curves exhibited a “moving” phenomenon for the same nominal wind attack angle under different initial ice accretion angles. This presents a significant variation in the amount of the ladder. When the



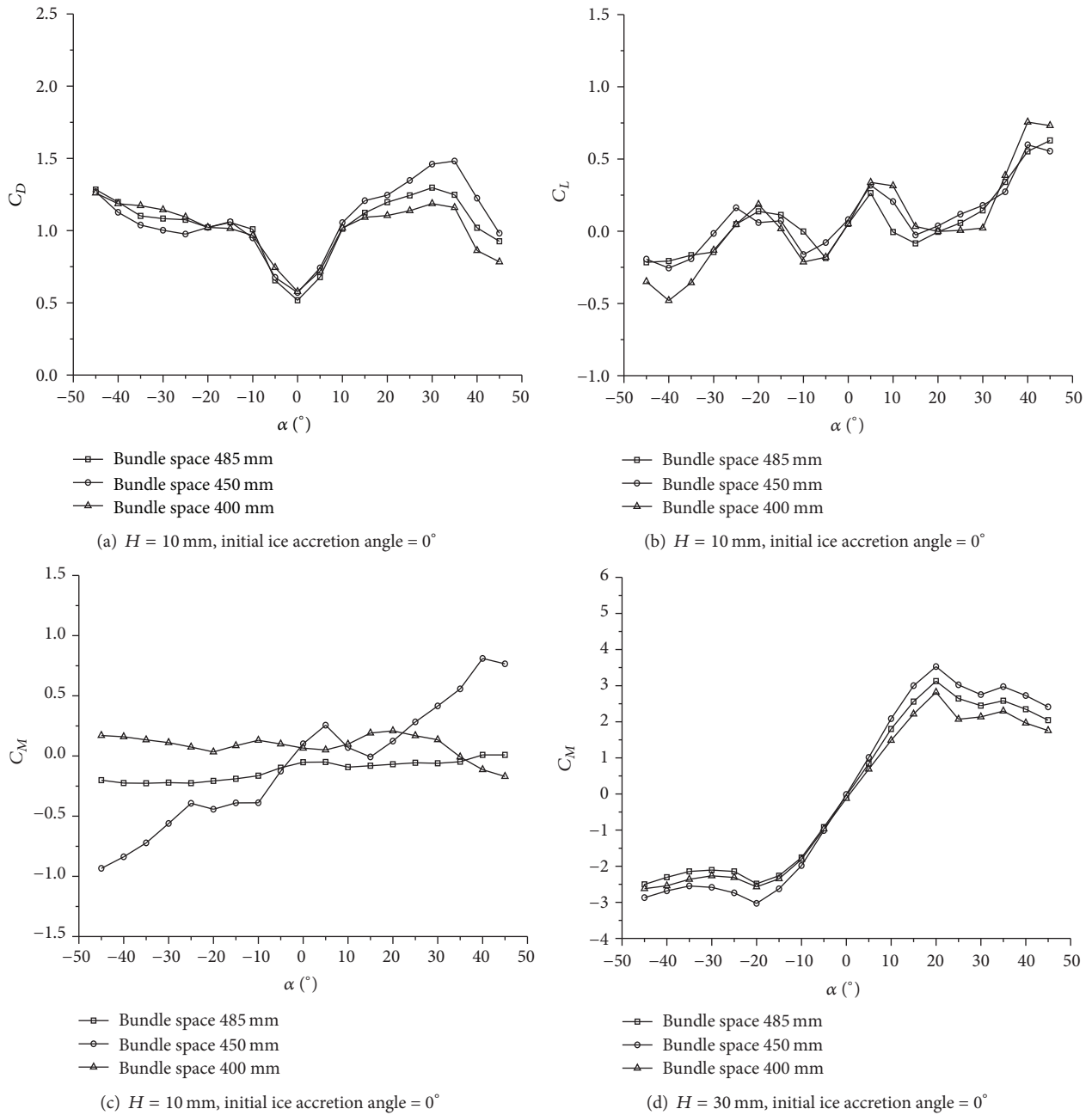

FIGURE 10: Effect of bundle space on the aerodynamic characteristics of subconductor 2 (thickness: 10 (30) mm, initial ice accretion angle:  $0^\circ$ ).

range of wind attack angle is larger (absolute value without  $20^\circ$ ), the lift and moment coefficients of the conductors are less affected by the change of the initial ice accretion angle, except the lift coefficient of leeward subconductor 2, which is interfered with by the wake interference. Therefore, it is necessary to consider the influence of the initial ice accretion angle.

**3.3. Influence of Bundle Space.** The aerodynamic coefficient curves of subconductor 2 varying with the wind attack angles under different bundle spaces are shown in Figure 10.

It is observed that the variation of the bundle space generally has little influence on the drag and lift coefficient, even for subconductor 2, which is greatly influenced by the wake interference. When the conductor is with thin ice coating ( $H = 10$  mm), the curves of moment coefficient are quite different under the different bundle spaces. This is due to the fact that the thin iced conductor's outline is close to blunt body and the wake interference between blunt bodies is complicated. When the conductor is with heavy ice coating ( $H = 30$  mm), the outline of the ice-coated conductor is closer to streamlined body, so the effect

of bundle space on moment coefficient becomes smaller.

#### 4. Conclusions

Wind tunnel tests were carried out to obtain the static aerodynamic characteristics of the widely used ice-coated 4-bundled conductors (LGJ400/35) in a transmission system with different ice thicknesses, initial ice accretion angles, bundle spaces, and wind attack angles. The main conclusions are as follows:

- (1) The windward conductor's outline is the key factor to affect the aerodynamic characteristics of iced conductors.
- (2) The influence of wake interference on the drag coefficient of subconductors is obvious. The interference angle range is larger than  $20^\circ$  and the curves of leeward conductors' drag coefficient have a sudden decrease phenomenon at some certain wind attack angles. This sudden decrease phenomenon gradually decreases with the increase of ice thickness.
- (3) The absolute values of the moment coefficients of leeward conductors are always larger than those of the windward conductors, which means the wake increases the moment coefficient.
- (4) When the conductor is with heavy ice coating, the curve of the lift and moment coefficient will form a sudden peak phenomenon at the angle of wind attack near  $\pm 20^\circ$ , and the galloping of the iced subconductor may occur near these two angles of wind attack.
- (5) The variation of initial ice accretion angle has a significant influence on the aerodynamic coefficients. The aerodynamic coefficient curves exhibit a "moving" phenomenon for the same nominal wind attack angle at different initial ice accretion angles. For the leeward subconductors, the "moving" of aerodynamic coefficient curves is not uneven due to the influence of wake interference.
- (6) The bundle spaces generally have a great influence on the moment coefficient of subconductor 2 for the conductors with thin ice coating. With the increase of ice thickness, the bundle spaces generally have little influence on the aerodynamic coefficients.

#### Conflicts of Interest

The authors declare that there are no conflicts of interest regarding the publication of this paper.

#### Acknowledgments

This work was supported by the National Natural Science Foundation of China (Grant no. 51478069) and Chongqing Natural Science Foundation (Grant no. CSTC2017JCYJB0210).

#### References

- [1] J. Wang and J.-L. Lilien, "Overhead electrical transmission line galloping: A full multi-Span 3-DOF model, some applications and design recommendations," *IEEE Transactions on Power Delivery*, vol. 13, no. 3, pp. 909–916, 1998.
- [2] T. Ohkuma and H. Marukawa, "Galloping of overhead transmission lines in gusty wind," *Wind and Structures, An International Journal*, vol. 3, no. 4, pp. 243–253, 2000.
- [3] J. Druez, S. Louchez, and P. McComber, "Ice shedding from cables," *Cold Regions Science and Technology*, vol. 23, no. 4, pp. 377–388, 1995.
- [4] J. P. Den Hartog, "Transmission Line Vibration Due to Sleet," *Transactions of the American Institute of Electrical Engineers*, vol. 51, no. 4, pp. 1074–1076, 1932.
- [5] O. Nigol, G. J. Clarke, and D. G. Havard, "Torsional stability of bundle conductors," *IEEE Transactions on Power Apparatus and Systems*, vol. 96, no. 5, pp. 1666–1674, 1977.
- [6] O. Nigol and P. G. Buchan, "Conductor galloping part I: den hartog mechanism," *IEEE transactions on power apparatus and systems*, vol. 100, no. 2, pp. 699–707, 1981.
- [7] O. Nigol and P. G. Buchan, "Conductor galloping part II: torsional mechanism," *IEEE Transactions on Power Apparatus and Systems*, vol. 100, no. 2, pp. 708–720, 1981.
- [8] C. B. Gurung, H. Yamaguchi, and T. Yukino, "Identification of large amplitude wind-induced vibration of ice-accreted transmission lines based on field observed data," *Engineering Structures*, vol. 24, no. 2, pp. 179–188, 2002.
- [9] P. van Dyke and A. Laneville, "Galloping of a single conductor covered with a D-section on a high-voltage overhead test line," *Journal of Wind Engineering and Industrial Aerodynamics*, vol. 96, no. 6-7, pp. 1141–1151, 2008.
- [10] C. B. Rawlins, "Analysis of conductor galloping field observations — Single conductors," *IEEE Transactions on Power Apparatus and Systems*, vol. 100, no. 8, pp. 3744–3753, 1981.
- [11] O. Chabart and J. L. Lilien, "Galloping of electrical lines in wind tunnel facilities," *Journal of Wind Engineering and Industrial Aerodynamics*, vol. 74-76, pp. 967–976, 1998.
- [12] Q. Zhang, N. Popplewell, and A. H. Shah, "Galloping of bundle conductor," *Journal of Sound and Vibration*, vol. 234, no. 1, pp. 115–134, 2000.
- [13] L. Zhou, B. Yan, L. Zhang, and S. Zhou, "Study on galloping behavior of iced eight bundle conductor transmission lines," *Journal of Sound and Vibration*, vol. 362, pp. 85–110, 2016.
- [14] J. Hu, B. Yan, S. Zhou, and H. Zhang, "Numerical investigation on galloping of iced quad bundle conductors," *IEEE Transactions on Power Delivery*, vol. 27, no. 2, pp. 784–792, 2012.
- [15] G. Diana, M. Belloli, S. Giappino et al., "Wind tunnel tests on two cylinders to measure subspan oscillation aerodynamic forces," *IEEE Transactions on Power Delivery*, vol. 29, no. 3, pp. 1273–1283, 2014.
- [16] P. Stumpf and H. C. M. Ng, *Investigation of aerodynamic stability for selected inclined cables and conductor cables*, University of Manitoba, Winnipeg, Canada, 1990.
- [17] J. Chadha and W. Jaster, "Influence of turbulence on the galloping instability of iced conductors," *IEEE Transactions on Power Apparatus and Systems*, vol. 94, no. 5, pp. 1489–1499, 1975.
- [18] W. Lou, J. Lv, M. F. Huang, L. Yang, and D. Yan, "Aerodynamic force characteristics and galloping analysis of iced bundled conductors," *Wind and Structures, An International Journal*, vol. 18, no. 2, pp. 135–154, 2014.

- [19] X. Li, K. Zhu, and B. Liu, "Numerical and experimental simulation on aerodynamic character of crescent-shaped iced conductor," *Applied Mechanics and Materials*, vol. 275-277, pp. 622–627, 2013.
- [20] D. Yan, Z. Lü, W. Lin, and W. Lou, "Experimental study on effect of turbulence intensity on the aerodynamic characteristics of iced conductors," *Gaodiyana Jishu/High Voltage Engineering*, vol. 40, no. 2, pp. 450–457, 2014.



# Hindawi

Submit your manuscripts at  
<https://www.hindawi.com>

