

PDF hosted at the Radboud Repository of the Radboud University Nijmegen

The following full text is a publisher's version.

For additional information about this publication click this link.

<http://hdl.handle.net/2066/17264>

Please be advised that this information was generated on 2021-09-28 and may be subject to change.

PHYSICO-CHEMICAL CHANGES OF ALUMINIUM IN MIXING ZONES: MORTALITY AND PHYSIOLOGICAL DISTURBANCES IN BROWN TROUT (*SALMO TRUTTA* L.)

HILDA E. WITTERS,*† SYLVAIN VAN PUYMBROECK,† ALEXANDER J. H. X. STOUTHART‡ and
SJOERD E. WENDELAAR BONGA‡

†Vlaamse Instelling voor Technologisch Onderzoek (VITO), Department of Environment, Boeretang, 200, B-2400 Mol, Belgium

‡University of Nijmegen, Department of Animal Physiology, Toernooiveld, NL-6525ED Nijmegen, The Netherlands

(Received 13 April 1995; Accepted 13 November 1995)

Abstract—A standardized laboratory setup, simulating field mixing zones that originate at the confluence of limed rivers with acidic, aluminium-rich, tributaries, has been developed. Detailed analyses of the chemical speciation of aluminium (Al) in relation to the biological response of brown trout were performed to identify the mechanism of unexpected high fish mortality in the above-mentioned mixing zones with pH levels above 6.0. Brown trout experienced an acute cumulative mortality (98% in 48 h) immediately after neutral and acidic, Al-rich, water had mixed. Mortality was only 60% within 48 h of exposure to the acid water with Al (pH 4.6 + 6.8 $\mu\text{mol Al/L}$), although the Al concentration in the mixing zone was less (2.8 $\mu\text{mol Al/L}$) at a nonharmful pH level (pH 6.4). Chemical speciation and ultrafiltration studies demonstrated that the transformation of low-molecular weight Al (<10 kD) into high-molecular weight Al (>10 kD), defined as Al polymerization, could better be related to the toxic response of fish, than the total Al concentration. The aging of polymerized Al forms (for 480 s) resulted in reduced fish mortality and less pronounced physiological stress. Brown trout in the initial mixing zone showed significantly increased plasma glucose and cortisol levels. Light and electron microscopy studies demonstrated serious damage to the skin: increased mucous secretion, a high ratio of acid to neutral glycoprotein-containing mucous cells, increased apoptosis, and infiltration of leucocytes and macrophages between the epithelial cells. Ionoregulatory parameters, which showed minor changes in fish in the initial mixing zone, did not allow explanation of acute fish mortality. Data on the ventilation frequency and the blood hematocrit, which both increased, gave support for the hypothesis that acute fish mortality in mixing zones could be caused by respiratory dysfunction.

Keywords—Aluminium Brown trout Toxicity Mixing zones Aluminium fractionation

INTRODUCTION

A serious decline or extinction of natural fish populations in the past decades in the northern temperate regions (Canada, Scandinavian countries, and elsewhere) has been described as a major consequence of atmospheric acid deposition [1-3]. Both field and laboratory studies have demonstrated that aluminium, which is easily mobilized from poorly buffered soils into surface waters, is the principal toxicant to fish, with a minor role for H^+ ions [4,5].

Aluminium is found to be most toxic in the pH range 4.8 to 5.4 [6,7], which is highly related to its aqueous speciation. Aluminium bound to ligands such as organic acids, fluoride, sulfate, and silicate is less toxic and only inorganic monomeric Al is claimed to contribute to acute toxicity [8-10]. At pH 4.0, aluminium mainly exists as the hexahydrate $\text{Al}(\text{H}_2\text{O})_6^{3+}$ (free ion). As pH increases, successive deprotonation of $\text{Al}(\text{H}_2\text{O})_6^{3+}$ yields the hydrolysis products $\text{Al}(\text{OH})(\text{H}_2\text{O})_5^{2+}$ and $\text{Al}(\text{OH})_2(\text{H}_2\text{O})_4^+$, which constitute the predominant forms of inorganic monomeric Al in the pH range 4.8 to 6.0. At circumneutral and basic conditions the anionic form $\text{Al}(\text{OH})_4^-$ occurs in solution [11]. Current theories on acute Al toxicity in the pH range 4.5 to 5.5 are based on interactions of cationic Al hydrolysis products with the gill surface ligands and cellular internalization [12-14]. Damage to the gill epithelium and intracellular Al accumulation causing necrosis and apoptosis of gill ion-transporting cells [15] have been described as the main causes of ionoregulatory and osmoregulatory dysfunctions. A greater inflammatory response

to Al-hydroxides, greater mucous production, and subsequent increased resistance to O_2 and CO_2 diffusion are additional causes of fish death after Al exposure [7,16].

However, recently, questions have been raised upon the mechanism of Al toxicity after toxicity of Al has been documented at pH levels from 6.0 to 6.5 [17]. In the mixing zone (pH 4.8-6.5; 50-240 $\mu\text{g Al/L}$) of a limed river with an acidic tributary, increased mortality ($\text{LT}_{50} = 7$ h) of Atlantic salmon (*Salmo salar* L.) and brown trout (*Salmo trutta* L.) was observed compared to the acidic river ($\text{LT}_{50} = 22$ h and 40 h for Atlantic salmon and brown trout, respectively). This mixing zone is a disequilibrium condition where a temperature-dependent polymerization of inorganic Al occurs as pH increases [17]. In field channel experiments in Norway, acidic lake water and neutral lake water were mixed. Chemical analyses of Al speciation were performed and biological responses of brown trout were investigated [18].

In this study, a laboratory set up has been developed to simulate such field observations under controlled conditions (e.g., with respect of temperature, flow rate, and water pH). To gain more insight into mixing zone toxicity a detailed analysis of the aqueous speciation of aluminium in relation to the biological response of fish was performed. The effects on several physiological parameters and skin ultrastructure were examined.

MATERIALS AND METHODS

Experimental animals

Brown trout of both sexes, 8 to 10 months old (mean weight 56 g, range 22-113 g), were obtained from a hatchery (Pisci-

* To whom correspondence may be addressed.

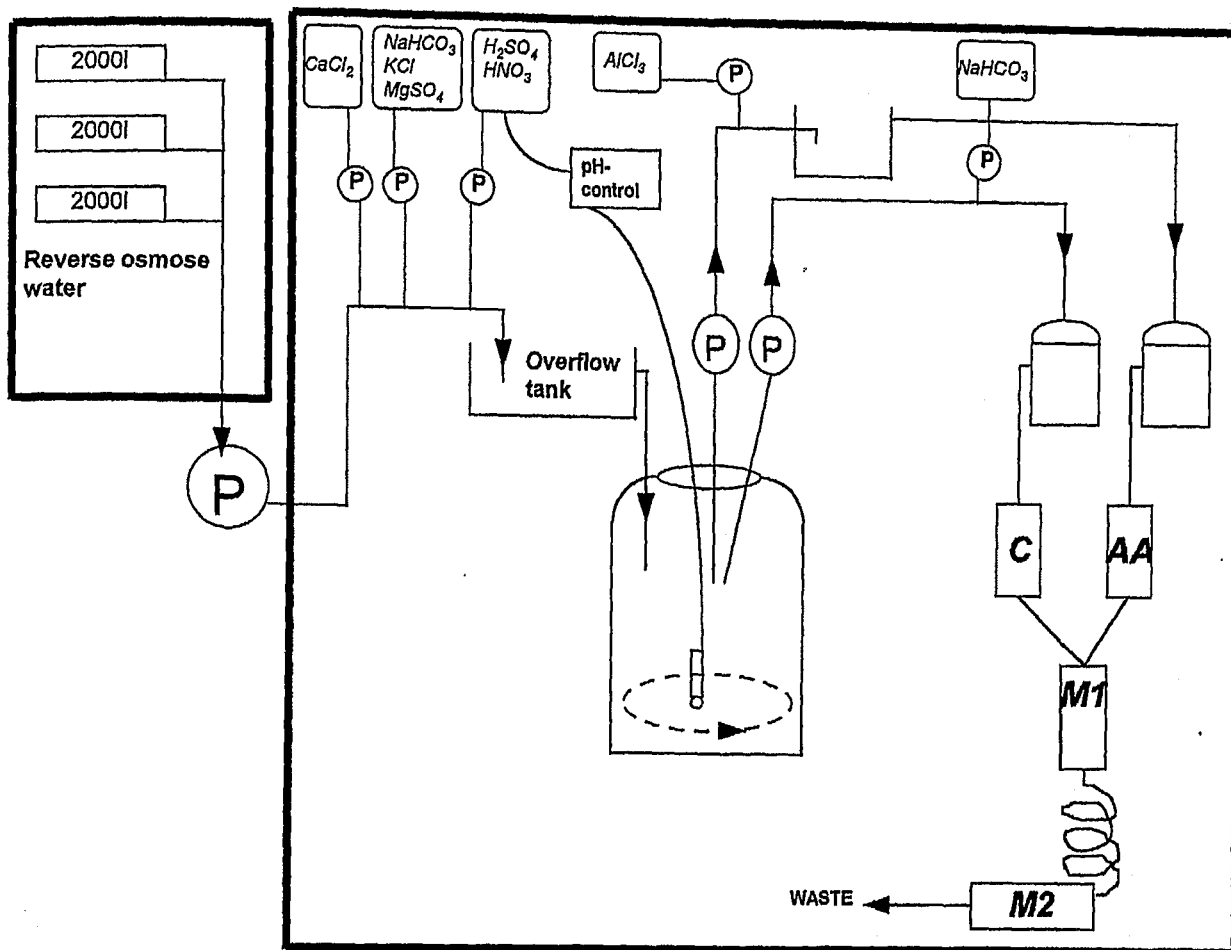

Fig. 1. A schematic presentation of the experimental set up of mixing zones in the laboratory at VITO-Mol.

culture Colette, Wavre, Belgium). They were stocked in 1,000-L fiberglass tanks that were continuously provided with aerated tap water (temperature 16°C; pH 8.6; $[\text{Na}^+] = 0.4$; $[\text{Ca}^{2+}] = 1.0$; $[\text{Cl}^-] = 0.3$, and $[\text{HCO}_3^- + \text{CO}_3^{2-}] = 0.9$ mmol/L). The fish were daily fed with commercially available trout pellets. The fish were maintained in these conditions at least 8 to 10 weeks prior to experimentation.

Experimental set up

In a separate temperature-controlled room, a laboratory set up was built to simulate mixing zones as they occur in the field where an acidic tributary enters a limed neutralized river [17]. A scheme of the set up is presented in Figure 1. Water demineralized by reverse osmosis (EU-R0-TEC, 01-A-1) was pumped at a rate of 180 L/h from 2,000-L tanks, which were kept at 15°C, into the experimental room. Mineral salts (NaCl , KCl , CaCl_2 , MgSO_4 , and NaHCO_3) were added with dosing pumps (Prominent Electronic, E1201). Then the water passed an overflow tank and ran into a 200-L reservoir. The pH was continuously measured in this reservoir and adjusted to pH 4.6 by an automatic pH controlling device (Prominent Dulcometer PHWSO14). This device was connected to the dosing pump just prior to the overflow tank where acid from a stock solution of 0.1 N H_2SO_4 : HNO_3 (2:1) was added. A stirrer and aeration were placed in the 200-L reservoir to obtain a homogeneous water quality. The water was then divided into two circuits, with

each receiving approximately 75 L/h by two pumps (Prominent Vario HM). One represented the acidic, Al-enriched system where Al was added by a dosing pump (Prominent Electronic E1201) from an AlCl_3 stock solution (100 mg Al/L in demineralized water, pH 4.0) to a nominal value of 200 μg Al/L. The second circuit represented neutralized water, which was prepared by dosing (Prominent Electronic, E1201) NaHCO_3 to the system to get a pH rise from 4.6 to 6.7. At the end of each circuit, another 150-L reservoir was installed with aeration and continuous pH control. From these reservoirs, the water ran into the fish-exposure chambers by overflow. The plexiglass chambers were 11 cm wide, 40 cm long, and 30 cm high, and contained a volume of 3.9 L water in the absence of fish. Four fish exposure chambers were used in these experiments: the first (control) received the neutralized water from the reservoir; the second (Acid + Al) received the acidic, Al-rich water from the other reservoir, both at a flow rate of 75 L/h; and the third fish chamber (MIX1) represented the initial mixing zone at the confluence of neutralized and acidic, Al-rich water, leaving the foregoing fish chambers. The aging time of water in the first mixing zone was 90 s. The mixed water (flow rate = 150 L/h) was then passed through a tube (residence time: 300 s) and entered a fourth fish chamber representing mixed water 390 s after mixing (MIX2). At the inflow of each fish exposure chamber, a baffle and aeration were provided to obtain an optimal and fast homogeneous distribution of the Al species. The wa-

terflow, pH, temperature, and total ion concentrations were daily measured.

Experimental procedure

Feeding was stopped 3 d prior to the start of the acclimation period. Then the fish were transferred to the experimental room and distributed among the four fish chambers, which were continuously supplied with neutralized (control) water. In each chamber 8 to 10 fish were kept during the 4-d acclimation period. The experimental exposure was started by supplying the fish chambers with experimental solutions. The overflow of the reservoir with acidic, Al-rich water (Acid + Al) was connected with the second fish chamber and water was changed within a few minutes. Due to the confluence of the neutralized water and the acidic, Al-rich water at the entrance of the third fish chamber, a mixing zone was established (MIX1) (flow rate = 150 L/h). The mixed water subsequently passed to the fourth fish chamber (MIX2) to replace the acclimation water. The fish were exposed for 48 h to these experimental conditions. The mortality was registered at 2-h intervals during the first 10 h of exposure and at 12-h intervals during the next 2 d. Ventilation frequency was estimated by counting opercular movements during 30 s for three different fish in each chamber after 2, 6, 24, and 48 h of exposure. Blood sampling of two to three fish in each experimental group was also performed at these time intervals after ventilation frequency was measured. Fish were rapidly killed by a blow on the head and the blood was collected by caudal puncture with a preheparinized syringe. The experiment was repeated five times to get enough data for each sampling point and each experimental group. Due to mortality in some groups, the number of fish in some groups decreased substantially during the experiments, resulting in a variation of data numbers from $n = 12$ to $n = 1$.

Analytical techniques

Water pH was measured with a Hamilton electrode (Liq-Glass) coupled to a pH meter (WTW, pH192). Low ionic strength buffers of pH 4.10 and pH 6.97 (Orion, No. 700001) were used for calibration and the water sample was diluted (1:100) with 3 M KCl to get comparable ionic strength levels. The concentrations of Na^+ , Ca^{2+} , and Mg^{2+} were measured by plasma emission spectrophotometry (Jarrell Ash, Atomcomp Model 750). The Cl^- concentration in the water was determined by segmented flow analysis (Skalar, model 5100). The total Al concentration in water samples was measured by graphite furnace (Type THGA) atomic absorption spectrophotometry (Perkin Elmer, model 5100 PC) after samples were acidified for at least 1 h to pH 1.0 with HCl.

Speciation studies of aqueous Al were performed using the Barnes-Driscoll extraction-cation-exchange method in combination with hollow fiber ultrafiltration [19]. Three replicate samples for each experimental condition were taken and independently processed. Four chemical fractions can be determined by the HQ/MIBK method [20,21] in which Al is bound to 8-hydroxyquinoline and extracted at pH 8.3 with methylisobutylketone within 20 s. The extracts were kept for 24 h at 4°C prior to spectrophotometric measurements (Perkin Elmer, Lambda 2) at room temperature. Absorbance measurements were carried out only at 395 nm. Corrections for iron interference were not performed because the iron concentration present in the water samples was below detection levels. The monomeric Al form (Al_1) was determined by direct extraction of water samples [21]. The samples were also run under standardized conditions

through an Amberlite IR-20 cation-exchange resin column. The aluminium present in the eluate was defined as nonlabile aluminium, often called organic monomeric Al, termed Al_0 [21]. The concentration of labile or inorganic monomeric Al (Al_1) was calculated as the difference between Al_0 and Al_1 . The total reactive aluminium (Al_1) was analyzed by HQ/MIBK extraction after acidifying untreated water samples with HCl to pH 1.0 for at least 1 h.

Further fractionation of water samples was performed using an Amicon H1P 10-20 hollow fiber cartridge, which allowed division of water samples into two molecular weight fractions. In this study, some experiments were performed with hollow fiber cartridges with a nominal molecular weight cutoff level of either 3 kD or 10 kD. The fractionation method of Barnes/Driscoll [20,21] was only performed on the filtrates obtained with the cartridge with a cutoff level of 10 kD. The Al speciation studies were performed in the experimental temperature-controlled room in order to exclude temperature effects and to reduce time between sample collection and treatment in order to minimize molecular weight transformation during analysis. The hollow fiber cartridge was set up in the immediate vicinity of the fish exposure chambers for the same reason. Some preliminary ultrafiltration experiments were performed in order to find out whether the ratio of high-molecular weight forms versus low-molecular weight forms could be different in the presence or absence of fish in the exposure chambers. Because no differences were found by this experiment, collection of water samples for ultrafiltration was performed in the absence of fish, thus omitting stress effects on fish during the experiments.

The study of the biological response of brown trout consisted of observations of mortality and ventilation frequency, and collection of blood samples for the analysis of several parameters. Some blood was distributed into ammonium heparinized microcapillary tubes (Clay Adams, No. 1025) and centrifuged for 10 min (Sarstedt, Desaspeed MH-2) to allow hematocrit determination. The remainder of the blood was centrifuged to obtain plasma. An automated analyzer (Hitachi 705) was used to determine $[\text{Cl}^-]$ (Hycel chloride test), glucose (Boehringer, automated analyses 704.067), and protein content (Boehringer, automated analyses 704.705) in plasma samples. $[\text{Na}^+]$, $[\text{Ca}^{2+}]$ and $[\text{Mg}^{2+}]$ were determined by argon plasma emission spectrophotometry (Jarrell Ash, Atomcomp. model 750) and $[\text{K}^+]$ was measured by atomic absorption spectrophotometry (Perkin Elmer, Model 5100 PC) in plasma samples diluted 1:200 with 0.01 N HCl. Plasma cortisol was determined in a radioimmunoassay (RIA) as described by De Man et al. [22]. The cortisol antiserum was produced by S. Klinger, St. Albans COO1/2. ^3H -labelled cortisol was purchased from Amersham International. Bound and free cortisol were separated by precipitation of the immunocomplex with Sac-Cel (Nichols Institute Diagnostics, The Netherlands), and diluted five times.

For histology, skin samples were taken from the ventral side, between the pectoral fins. For light microscopy, tissues were fixed in Bouin's solution and, after dehydration in a graded series of ethanol and xylene, embedded in paraplast. Cross sections of 7 μm thickness were mounted on glass slides and stained for 10 min with Alcian Blue (pH 2.5) to identify mucous cells containing acid glycoproteins. Of every skin sample, 25 fields (each with a length of 1 mm of cross-sectioned epidermis) were examined to determine mucous cell density and the ratio of mucous cells containing acid (Alcian blue positive) or neutral glycoproteins (Alcian blue negative). For electron microscopy, tissues were fixed for 10 min in 3% glutaraldehyde buffered in

Table 1. Major water quality parameters (mean values \pm SEM, $n = 4$) in the fish exposure chambers

	Control (neutralized water)	ACID + Al (acidic, Al-enriched water)	MIX1 (mixing zone, aging time = 90 s)	MIX2 (mixing zone, aging time = 480 s)
pH	6.7 \pm 0.1	4.6 \pm 0.1	6.4 \pm 0.1	6.4 \pm 0.1
Temp. ($^{\circ}$ C)	16 \pm 1	16 \pm 1	16 \pm 1	16 \pm 1
Na ⁺ (μ mol/L)	565 \pm 22	409 \pm 17	487 \pm 22	487 \pm 17
Mg ²⁺ (μ mol/L)	14 \pm 1	13 \pm 1	14 \pm 1	14 \pm 1
Ca ²⁺ (μ mol/L)	25 \pm 3	25 \pm 3	25 \pm 3	25 \pm 3
Cl ⁻ (μ mol/L)	243 \pm 11	262 \pm 8	257 \pm 11	260 \pm 14
Al _{tot} (μ mol/L)	n.d. ^a	6.82 \pm 0.44	2.78 \pm 0.26	2.78 \pm 0.37

^an.d. = nondetectable by plasma emission spectrophotometry (less than 1 μ mol/L).

sodium cacodylate (0.1 M, pH 7.4), and postfixed for 1 h in 1% osmium tetroxide in the same buffer. Ethanol-dehydrated tissues were embedded in Spurr's resin. Ultrathin sections, collected on 150-mesh copper grids, were contrasted with uranyl acetate and lead citrate, and examined in a Jeol 100 CXII transmission electron microscope.

Data analysis

All values from chemical analysis are presented as means \pm standard error of the mean (SEM). Biological data were first examined for fit to a normal distribution and homogeneity of variance. Physiological endpoints from all exposure groups (control, Acid + Al, MIX1, MIX2), exposure durations (2, 6, 24, and 48 h), and experimental runs (five) were analyzed for significant effects of treatment, exposure time, experimental replicate, and interactive effects using MANOVA. Main effects appeared from experimental treatment and exposure duration. Individual values for experimental runs were pooled for each treatment and each exposure time. Mean values were presented in the figures and compared using a Student's *t* test or a Duncan's multiple range test. The treatment groups, Acid + Al, MIX1, and MIX2 were compared with the control group and statistical differences are indicated by asterisks in the figures (*: $p < 0.05$; **: $p < 0.01$; ***: $p < 0.001$). Physiological responses were also compared between MIX1 and MIX2 at 2, 6, and 24 h and statistical differences are indicated by plus signs in the figures (+: $p < 0.05$; ++: $p < 0.01$; +++: $p < 0.001$). The latter comparison was not made at 48-h exposure because only one fish ($n = 1$) survived for 48 h in MIX1. All calculations were performed using the Statistica[®] (Statsoft[®], Tulsa, OK, USA) statistical software package.

RESULTS

Water chemistry

The data on the measurements of several water quality parameters in the fish exposure chambers are presented in Table 1. In the control group, the pH level was continuously kept at 6.7. The pH level in the mixing zones, MIX1 and MIX2, was slightly less (pH 6.4) but remained the same in both exposure chambers during the whole experiment. In the Acid + Al group, the mean pH value was 4.6 and the measured Al level was 6.82 μ mol/L. The total level of Al was reduced by approximately 50% in the mixing zones, as could be expected from equal flow rates of neutralized and acidic, Al-enriched water.

More details on water chemistry were obtained from ultrafiltration and Al fractionation studies. In a preliminary experiment, comparative ultrafiltration, with a 3-kD and a 10-kD membrane, of water samples from the Acid + Al, the MIX1,

and the MIX2 group was performed (Fig. 2). It was demonstrated that the Al fraction with a size less than 3 kD was low and of the same order of magnitude in each group (respectively 8, 12, and 14% of total Al in the Acid + Al, MIX1, and MIX2 groups). The distribution of low- and high-molecular weight fractions differed between experimental groups when ultrafiltration with a cutoff of 10 kD was carried out. In the Acid + Al group, the major fraction of Al was of a size less than 10 kD (70%) compared to respectively 14 and 15% in MIX1 and MIX2. The same distribution of low- versus high-molecular weight fractions of Al was found when ultrafiltration was performed with water samples collected from fish exposure chambers containing five brown trout each (Fig. 2). It was concluded from these results that further Al speciation studies should be performed with a hollow fiber cartridge with a cutoff level of 10 kD and that watersamples should be collected before or at the end of the biological experiments (no fish in exposure chambers).

Results on combined ultrafiltration and fractionation studies are presented in Figure 3. The figures illustrate that the total reactive Al (Al_r) highly corresponds to the monomeric form (Al₁) in the Acid + Al group. Most Al in this experimental group was in a low-molecular weight form (<10 kD): 69% of

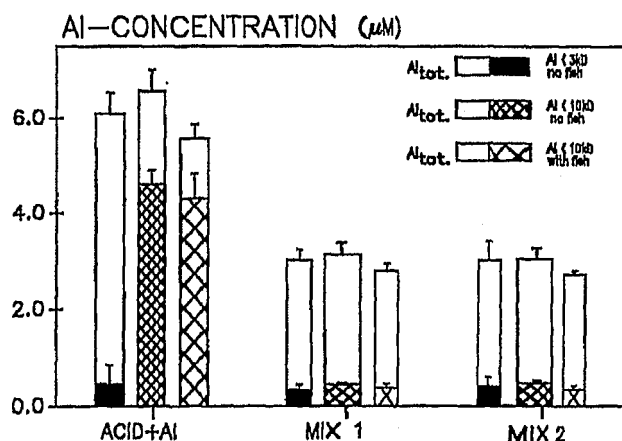

Fig. 2. The concentration of total Al (complete bar) and the ultrafiltrable fraction (filled or shaded parts) of the total Al in water samples from three experimental groups: Acid + Al (pH 4.6), MIX1 (pH 6.4), and MIX2 (pH 6.4). The first two bars in each experimental group represent total Al with ultrafiltrable fraction of, respectively, molecular weight <3 kD (■) or <10 kD (▨). The third bar in each experimental group represents data obtained in the presence of five fish with total Al and the ultrafiltrable fraction of a molecular weight <10 kD (▨). Mean values with SEM are presented ($n = 3$).

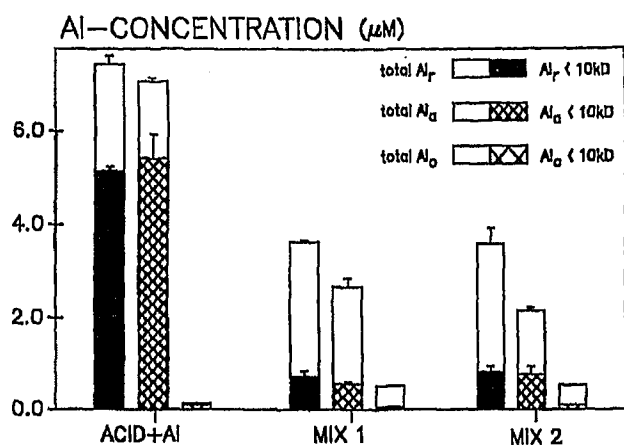

Fig. 3. The concentration of the total Al (complete bar) and the ultrafiltrable fraction with a molecular weight cutoff of 10 kD (filled or shaded part) of different Al fractions: total reactive Al (Al_r) (■), monomeric Al (Al_m) (▨), and monomeric organic Al (Al_o) (▩) in water samples from three experimental groups: Acid + Al (pH 4.6), MIX1 (pH 6.4), and MIX2 (pH 6.4). Mean values with SEM are presented ($n = 3$).

Al_r and 73% of Al_m . The amount of monomeric organic Al was negligible (3% of total Al_r), which is as expected because of the absence of organic substances in our artificially prepared experimental solutions. The total Al_r was reduced 50% in the mixing zone (MIX1 and MIX2) compared to the Acid + Al group. The monomeric Al (Al_m) was 25% (MIX1) and 38% (MIX2) lower than the total Al_r . The latter appeared to be the main chemical difference between MIX1 and MIX2. The occurrence of Al polymerization in the mixing zone is demonstrated by the results of the ultrafiltration. Most Al (80% in MIX1 and 77.3% in MIX2) has a molecular weight size of more than 10 kD, which is the reverse of the size distribution in the Acid + Al group. A significant amount of monomeric organic Al (Al_o) (14 and 14.4% of Al_r in MIX1 and MIX2) was measured by the cation-exchange method.

Fish mortality

Data on cumulative mortality of brown trout in each experimental condition ($n = 40-44$ at $t = 0$, with decreasing numbers due to intermittent blood sampling) are presented in Figure 4. The rate of mortality was highest in MIX1 and increased up to 98% after 48 h of exposure. The mortality in the Acid + Al group started after 24 h of exposure and increased up to 60%. Fish mortality in MIX2 remained low (14%) compared to MIX1 despite similar chemical conditions for pH and total Al concentration.

Physiological parameters

The data on changes of hematological, respiratory, and ionoregulatory parameters are presented in Figure 5. Measurements of the ventilation frequency (Fig. 5A) gave an indication of respiratory stress. An increase in the ventilation frequency was significant ($p < 0.001$) after 3 h in all experimental groups compared to the control. The ventilation frequency in MIX1 was also significantly higher compared to MIX2 during the first 24 h of exposure. Data on hematocrit values as presented in Figure 5B demonstrate that two groups, Acid + Al and MIX1, were most affected: an immediate increase in the hematocrit value was observed in MIX1, which remained high, whereas the hematocrit value in the Acid + Al group increased with

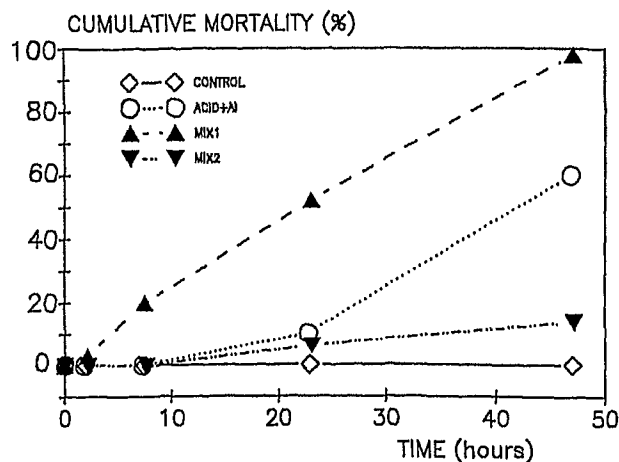

Fig. 4. Cumulative mortality of brown trout as a function of time of exposure to either control (◇), Acid + Al (○), MIX1 (▲), or MIX2 (▼) water.

some delay and became significantly higher than the control after 24 h of exposure ($p < 0.001$). Comparison of MIX1 and MIX2 showed significant differences at 6 and 24 h of exposure. Figure 5C and D show that ionoregulatory disturbances were most pronounced in the Acid + Al group. Both plasma $[Na^+]$ and $[Cl^-]$ decreased to significantly ($p < 0.01$) lower values as a function of time during the first 24 h. Slight decreases of plasma $[Cl^-]$ were seen in MIX1 and both plasma $[Cl^-]$ and plasma $[Na^+]$ in MIX2 were slightly decreased. The extremely low value at 48 h for plasma $[Na^+]$ and $[Cl^-]$ in MIX1 probably represents the physiological condition of a dying fish ($n = 1$ at 48 h in MIX1). The levels of $[Ca^{2+}]$, $[Mg^{2+}]$, and $[K^+]$ were also measured in blood plasma but no significant changes were observed in any of the experimental groups. The general stress condition of fish in the exposure groups is represented by the increased glucose and cortisol level in the blood plasma. The significant changes of the glucose level in the MIX1 and Acid + Al group were of the same order of magnitude (Fig. 5E). Plasma cortisol levels of the Acid + Al group showed a fourfold increase at 6 h ($p < 0.001$). The levels of the MIX1 group increased 20-fold at 6 h and remained elevated for 24 h ($p < 0.001$). The levels of the MIX2 group increased slightly at 2 h ($p < 0.02$) and threefold at 6 h ($p < 0.001$), but decreased close to control levels at 24 h (Fig. 5F). Significant differences were observed for plasma glucose and cortisol levels between MIX1 and MIX2 after 6 and 24 h of exposure.

Light and electron microscopy of the skin

In the skin of control fish the total number of mucous cells and the number of mucous cells containing acid or neutral glycoproteins was constant during the experiment (Fig. 6A). The ratio of mucous cells containing acid glycoproteins to mucous cells containing neutral glycoproteins was about 0.5 (Fig. 6B). The total number of mucous cells in the MIX1 group was significantly ($p < 0.05$) decreased after 2 h of exposure, whereas in the Acid + Al and MIX2 groups the decrease became significant ($p < 0.05$) after 24 h. The ratio of acid to neutral glycoprotein-containing mucous cells increased significantly at 6 h in the MIX1 group and at 24 h in the Acid + Al and the MIX2 groups (Fig. 6B).

The epidermis of the control fish in general conformed to the recent description by Iger et al. [23]. The epidermis was

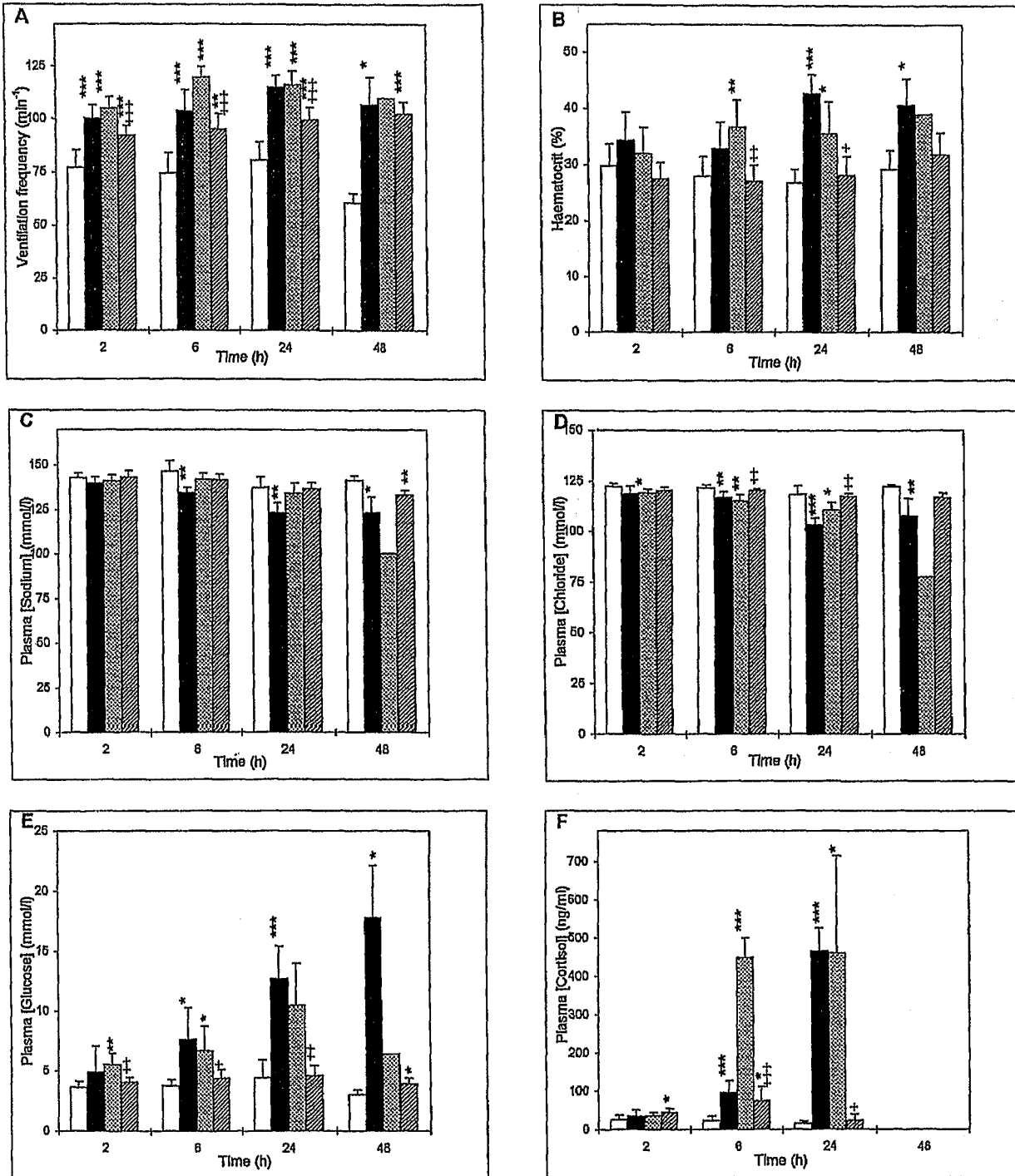

Fig. 5. Physiological parameters: (A) ventilation frequency, (B) hematocrit, (C) plasma sodium concentration, (D) plasma chloride concentration, (E) plasma glucose concentration, and (F) plasma cortisol concentration in brown trout as a function of time of exposure to either control (□), Acid + Al (■), MIX1 (▨), or MIX2 (▩) water. Mean values with 95% confidence intervals are presented. Plasma cortisol levels were not determined after 48 h of exposure. At 48 h only one fish survived in MIX1, which is represented as a single value. Significant differences with the control group for each time interval are indicated with asterisks: * $p < 0.05$, ** $p < 0.01$, *** $p < 0.001$. Significant differences of MIX2 in comparison with MIX1 at 2, 6, and 24 h are indicated with plus signs: + $p < 0.05$, ++ $p < 0.01$, +++ $p < 0.001$.

mainly composed of filament cells and mucous cells. Most of the mucous cells contained electron-transparent secretory granules, probably representing neutral glycoproteins (Fig. 7A). Very few filament cells showed the cytoplasmic and nuclear densification typical for apoptosis. In these cells transparent secretory granules were only occasionally observed, and were

exclusively in the upper layer of filament cells. Macrophages and lymphocytes were scarce. Contrastingly, in the epidermis of the Acid + Al and MIX1 groups phenomena of apoptosis as well as transparent secretory granules were very common in the upper layers of filament cells. In the upper cell layer, the intercellular spaces were enlarged (Fig. 7B and C). Numerous

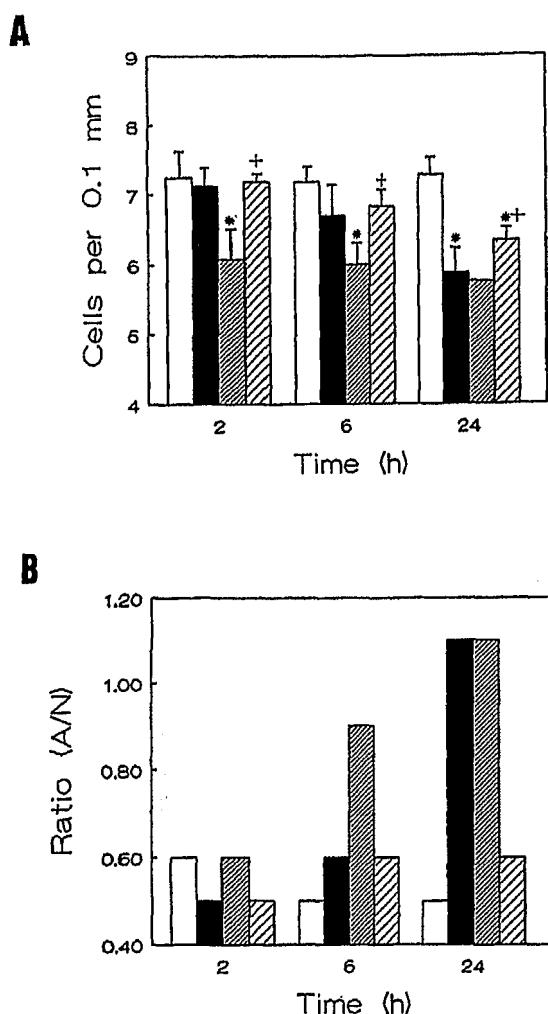

Fig. 6. Number of mucous cells (both Alcian Blue-positive and -negative cells) in the epidermis (A) and ratio of Alcian Blue-positive (acid glycoproteins = A) and Alcian Blue-negative (neutral glycoproteins = N) mucous cells in the epidermis (B). The experimental groups are control (□), Acid + Al (■), MIX1 (▨), and MIX2 (▩). Means \pm SEM; $n = 5$ (except at 6 h: $n = 6$ in MIX1 and MIX2; at 24 h: $n = 6$ in Acid + Al, $n = 2$ in MIX1, $n = 4$ in MIX2). Significant differences compared to control are indicated with asterisks (* $p < 0.05$) and significant differences between MIX1 and MIX2 are indicated with plus signs (+ $p < 0.05$).

lymphocytes were present between the filament cells (Fig. 7D and E). Macrophages were also common in these areas (Fig. 7E). The condition of the epidermis of the MIX2 fish was intermediate between that of the controls and the Acid + Al and MIX1 groups. The number of mucous cells was decreased in the Acid + Al and MIX1 groups, which was mainly due to the disappearance of these cells from the upper cell layers. In the MIX2 group, more than in the Acid + Al and MIX1 groups, differentiating mucous cells were observed in the lower layers of the epidermis of fish exposed for 24 and 48 h. Many of the differentiating mucous cells contained secretory granules with electron-dense cores, probably representing neutral glycoproteins (Fig. 7F).

DISCUSSION

Experimental set up

This paper presents the first results from standardized laboratory studies that simulate an in situ mixing zone of a limed

river and an acidic tributary, as was first described by Rosseland et al. [17]. The laboratory approach allowed us first to eliminate the poorly predictable interference of physicochemical parameters on Al speciation, such as organic carbon and seasonal or diurnal temperature changes, and second to perform a detailed physiological evaluation of the biological responses of exposed fish.

Comparison of the data on Al chemistry and mortality of brown trout in the laboratory mixing zone set up (Figs. 3 and 4) with the field observations [17,18,24] confirmed that the effects on fish were also in line with the field observations. The highest mortality (98%) was seen in the initial mixing zone (MIX1) with low total Al levels (2.8 $\mu\text{mol/L}$) at pH 6.4. This confirms the very high toxicity of Al in freshly mixed acidic and neutral water at a pH at which Al, until recently [17] was considered not toxic. The mortality was reduced to 15% when the mixed water (2.8 $\mu\text{mol Al/L}$, pH 6.4) was aged for 480 s (Fig. 4). Mortality was intermediate in the group exposed to higher Al levels (6.8 $\mu\text{mol/L}$) at pH 4.6. It is evident that Al toxicity to fish is not related to the total Al concentration in the water and that it neither is limited to the pH range 4.5 to 6.0 [7,11,25].

Water chemistry

Complexing agents known to influence speciation and bioavailability and hence toxicity of Al do not differ between the experimental groups. Compounds such as F^- , organic substances (e.g., humic or fulvic acids), or H_4SiO_4 that reduce Al bioavailability and toxicity [8–10] were not present in any of the experimental solutions. Calcium, which at elevated levels should mitigate toxic effects of Al at low pH by gill surface interactions [6], remained at the same low level of 2.5 $\mu\text{mol/L}$ in all the experimental groups (Table 1). The pH, the Al concentration, and the age of the experimental solutions for MIX1 and MIX2 remain the crucial parameters that differ between the experimental groups.

Most laboratory studies on Al toxicity to fish and invertebrates have described the pH-related toxicity as a function of the occurrence of soluble monomeric Al species. At low pH, $\text{Al}(\text{H}_2\text{O})_6^{3+}$ is the predominant form, which is converted to $\text{Al}(\text{OH})(\text{H}_2\text{O})_5^{2+}$ and $\text{Al}(\text{OH})_2(\text{H}_2\text{O})_4^+$, due to successive deprotonation as pH increases. As pH increases above 6.2, the anionic form, $\text{Al}(\text{OH})_4^-$, becomes the predominant one. Precipitation of Al as $\text{Al}(\text{OH})_3$ has been described [6,26] only in oversaturated solutions when inorganic Al-OH forms exceed gibbsite solubility. Our results from ultrafiltration studies with a hollow fiber cartridge with a molecular weight cutoff of 3 kD demonstrated, however, that in acid water (pH 4.6), only a minor fraction (~10%) of the Al forms had a size less than 3 kD. Thus only a small portion of Al in acidic water could be present in the monomeric form. At pH 4.6, about 60% of the Al was found to have a molecular weight between 3 and 10 kD. These results demonstrate that polymerization of monomeric Al-OH forms to high-molecular weight molecules (>3 kD) can occur in artificially prepared experimental solutions in the laboratory even at pH < 5.0.

When pH was increased from 4.6 to 6.4 (in MIX1 and MIX2) polymerization appeared to be more pronounced, because 85% of the total Al had a molecular weight higher than 10 kD. The likelihood of Al polymerization as a function of a pH increase in natural waters has been described by Driscoll and Schecher [11]. The monohydrated monomeric Al ions may form a dimer by a dihydroxide bridge. This form is considered unstable but

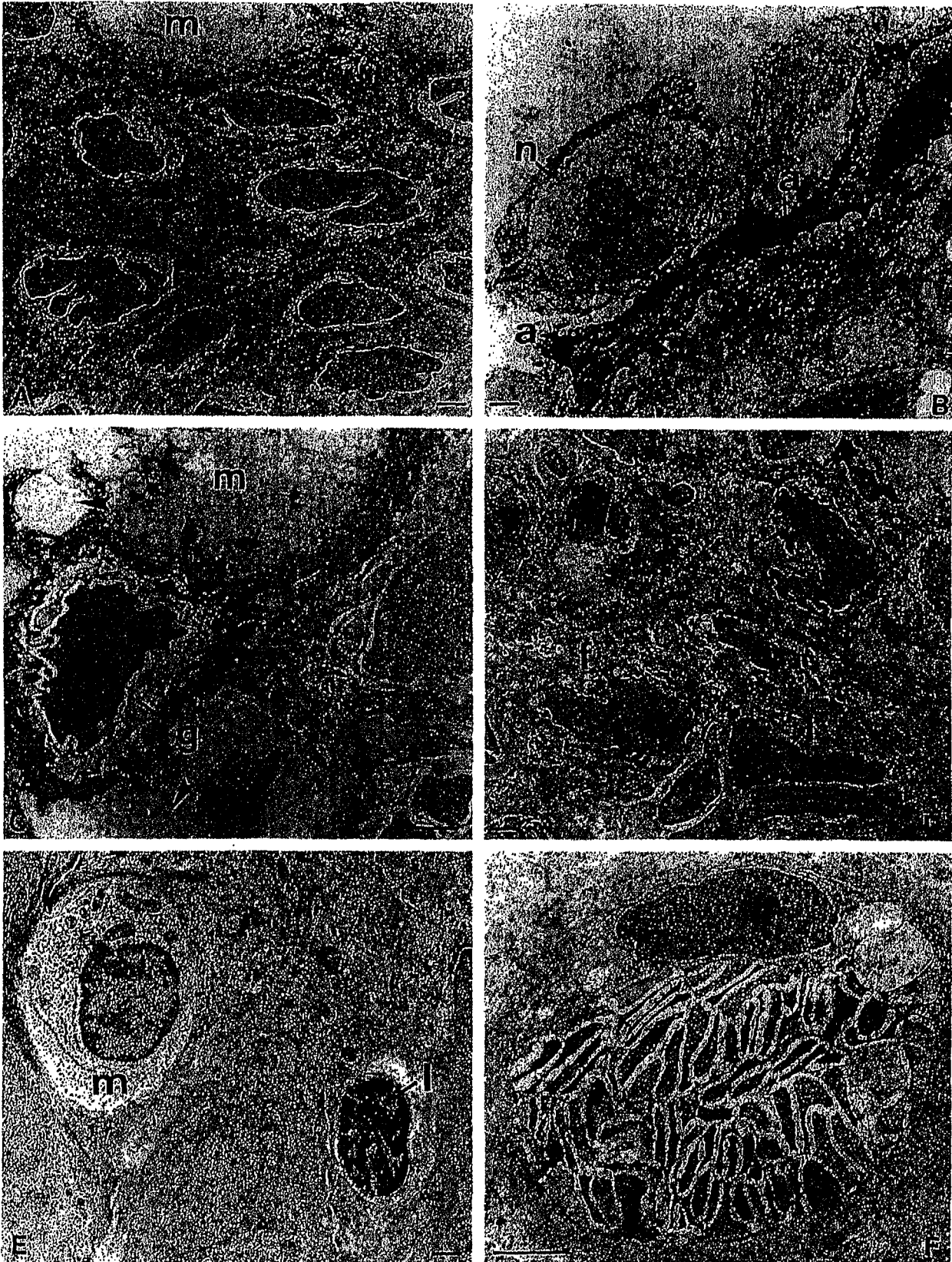

Fig. 7. Electron micrograph of the epidermis of a brown trout; bars represent 1 μm . (A) Control, showing middle part of the epidermis with many filament cells and part of a mucous cell with transparent secretory granules (m). (B) MIX1 group, 24 h. Upper layers of the epidermis showing filament cells with necrotic swellings (n) and apoptotic filaments cells (a); some filaments contain cells with secretory granules (arrow heads). Intercellular spaces are distended (arrows). (C) Acid + Al group, 24 h. Upper cell layers of epidermis, showing filament cell with secretory granules (g), distended intercellular spaces (arrow heads), and a mucous cell (m). (D) MIX1 group, 24 h. Middle part of the epidermis showing filament cells (f) and lymphoid cells (l). (E) Acid + Al group, 24 h. Middle part of epidermis, showing a macrophage (m) and a lymphocyte with an apoptotic nucleus (l). (F) MIX1 group, 24 h. Middle part of the epidermis, showing mucous cell with dense-cored secretory granules.

may result in the formation of a stable Al polymer in a ring structure, formed by six Al hydroxide octahedra $Al_6(OH)_{12}^{6+}$ molecules. These ring-shaped polymers may further coalesce to double- or triple-ring structures ($Al_{10}(OH)_{22}^{2+}$ or $Al_{13}(OH)_{30}^{2+}$). More than 10 Al polymer species have been proposed in the literature [11].

The polymeric species that occur in mixing zones have yet to be identified. It seems from the comparison of Al chemistry data between MIX1 and MIX2 that different high-molecular weight polymers occur. The difference between total Al_i and total Al_e points to the presence of nonextractable (at least within 20 s in the HQ/MIBK method of Barnes and Driscoll [20,21]) polymeric Al forms. This amount (Total Al_i - Total Al_e), however, is twice as high in MIX2 as in MIX1. This may be due to the presence of aged Al polymers that are less reactive (more or less nonextractable). This difference in chemical species (aged polymeric Al) between MIX1 and MIX2 has to be further studied in order to verify its impact on observed differences in physiological responses. Another fraction of polymeric Al (high molecular weight) in the mixing zone is identified as Al_o in Figure 3. The cation-exchange method presented by Driscoll [21] has especially been used in order to distinguish between monomeric inorganic Al, which is retained by the column, and the monomeric nonlabile, so-called organic-bound Al, which is collected in the eluted sample. Our study, which is performed without organic substances, gives evidence that the nonexchangeable fraction can also contain the inorganic stable high-molecular weight polymeric forms with low charge density, which cannot be retained by the ion-exchange column. A revision of the speciation method of Barnes and Driscoll [20,21] with respect to identification of the chemical fractions seems desirable in light of the polymerization processes. A third significant portion of high-molecular weight forms in the mixing zones is part of the inorganic Al_i fraction, which is calculated as the difference between Al_i and Al_e. The amount of high-molecular weight Al_i (>10 kD) is highest in MIX1 (44 μmol/L) and of the same order of magnitude as in the group Acid + Al (44.3 μmol/L). The high-molecular weight Al_i fraction decreased as a function of aging of the mixed solution to 26 μmol Al/L in MIX2. These data indicate that the total amount of high-molecular weight Al_i polymers is not related to the extreme mortality in MIX1. It rather could be due to the kinetic transformation of low-molecular weight Al forms to high-molecular weight Al forms as pH is increasing in the mixing zone. Deposition studies with the tracer Al-26 did demonstrate that the ongoing polymerization of low-molecular weight Al forms (<10 kD) was the source of elevated deposits of Al on the gills of fish in mixing zones. The high-molecular weight forms in the mixing zone did not appear to contribute to the gill Al accumulation [27].

Biological response

Our laboratory studies demonstrated unexpectedly high toxicity of Al (2.8 μmol/L) at pH 6.4. Mortality data in MIX1 were similar as documented in mixing zones in field studies [17,18,24]. The underlying mechanism, however, is not yet fully understood.

The toxicity of Al to fish in the pH range 4.2 to 5.5 has been extensively studied in the past 10 years [5,7,9,25,26,28,29]. The toxicity has been attributed to a dual process: failure of ionoregulation caused by a combination of Al and H⁺ effects, and respiratory failure, prevailing at moderate pH levels (pH 5.0–5.5), induced mainly by Al. Measurements of several physiological parameters in our laboratory experiments gave some

indication that disturbances of ionoregulatory functions were most pronounced in the Acid + Al group and less important than effects on ventilation frequency and stress parameters in MIX 1. Ionoregulatory changes, as shown by plasma [Na⁺] and [Cl⁻] levels were most pronounced in the Acid + Al group. Both the total ion loss and the initial ion loss rate were of the same order of magnitude as could be expected from former studies on pH and Al toxicity [16], and were consistently higher compared to fish in MIX1, which showed the highest mortality rate. Field studies with Atlantic salmon also have confirmed that the ionoregulatory failure was of lesser importance in mixing zone conditions than in Al-containing acidic water [24].

Studies on carp and trout have shown that acidic water induces a typical stress response in these animals. This response is indicated by increases in plasma cortisol and glucose, and, in the skin, increased mucous secretion, a higher ratio of acid to neutral glycoprotein-containing mucous cells, increased apoptosis, stimulated secretory activity in the upper layers of epidermal filament cells, and infiltration of leucocytes and macrophages between the epithelial cells. These phenomena were also observed in fish exposed to Cu, Cd, or a sudden increase in water temperature [23,30,31]. The very prominent presence of these phenomena in the surviving fish of the Acid + Al and MIX1 groups, and to a lesser extent in the MIX2 group, further confirms the stressful impact on fish of both the Al-containing acidic water and the mixing zone conditions.

In line with the mortality data, the extremely high cortisol levels of the MIX1 group point to freshly mixed neutral and acidic water as the most toxic of the three conditions tested. Cortisol, the main end product of the hypothalamo-pituitary-interrenal axis in fish, is known to increase plasma glucose levels as well as mucous secretion and the secretory activity of the filament cells. The observed reduction of the number of mucous cells in the experimental groups is likely a result of intense mucous secretion, combined with a rather slow formation rate of new mucous cells. An increase in Alcian Blue-positive cells (cells producing acid rather than neutral glycoproteins), as observed in particular in the MIX1 group, has been reported earlier in trout exposed to stressors such as Cu, Cd, or a temperature shock [23,30,31]. The secretory granules produced by the filament cells of stressed fish contain antibacterial enzymes secreted at the epidermal surface [23,30], probably in response to structural damage inflicted upon the skin by stressors. The presence of necrotic and apoptotic cells in the upper epidermal layers observed in the experimental groups indicates that the experimental treatments all caused substantial damage to these cells. This further explains the presence of large numbers of leucocytes in the epidermis, probably attracted by antigens penetrating destabilized skin from the water [23,30].

An increase in the blood hematocrit value has often been shown to be a good indicator of Al toxicity. The high hematocrit value in Al-exposed fish has been explained on one hand by an increased red blood cell volume caused by osmotic changes due to ion losses from the blood plasma and on the other hand by increased numbers of red blood cells as a result of adrenergic-induced splenic contraction in hypoxic conditions [7,16,32]. Our results demonstrated a rapid increase in the hematocrit value in MIX1 during the first 6 h. The pattern was similar to the change in the ventilation frequency. We will further investigate whether the increased hematocrit values in MIX1 are mainly a reflection of respiratory dysfunctions. The increase in the ventilation frequency is related to the presence of Al in the mixing zone. Preliminary experiments were performed with a mixed water

flow of control water and acidic water (without Al). No mortalities or changes in ventilation frequency were observed in brown trout during a 7-d exposure period.

Acute respiratory stress in brown trout (within 3–6 h) in MIX1 is suggested thus far as the primary cause of death in our experiments. When mixed experimental solutions were aged (MIX2), ventilation frequency in fish was increased with some delay and lower values were reached. This could explain the low mortality rate. Chemical speciation analyses of Al polymers still must be improved, because they do not yet provide enough evidence for a different pattern of Al polymerization between MIX1 and MIX2 (except for the difference $Al_3 - Al_1$), which might support the significantly different response between both groups for several parameters (hematocrit, ventilation frequency, plasma glucose, and cortisol). The ongoing polymerization of Al in mixed solutions, which is the kinetic transformation of low-molecular weight to high-molecular weight Al forms, is suggested to cause interference with respiratory gas exchange [33]. Oughton et al. [27] demonstrated deposits of Al on fish gills in mixed waters as a result of polymerization of low-molecular weight Al forms. A physical barrier of deposits of Al on the gills due to the polymerization of low-molecular weight forms in the gill microenvironment may interfere with respiration.

Except for the data on hematocrit and ventilation frequency, no experimental evidence is available to identify the primary cause of fish death in mixing zones. Future experiments will need to support the hypothesis that respiratory dysfunction is likely the cause of death, by simultaneous measurements of Al polymerization in mixed water, Al deposition on gills, and additional respiratory parameters in exposed fish.

These experimental studies clearly illustrated that metal toxicity in dynamic systems cannot be derived from the total concentration of the metal (e.g., Al) only. Changes of chemical species, such as through the polymerization process, should be focussed on when waters of different physicochemical quality (pH, temperature, ionic strength) meet at the confluence of rivers or when wastewater is discharged into river systems.

Acknowledgement—This study is part of a joint EC research project supported by the EC programme Environment (Contract EV5V-CT92-0073). We wish to express our gratitude to J. Patyn for assistance in statistical data analysis and to E. Wuyts for technical help and animal care.

REFERENCES

- Beamish, R.J., W.L. Lockhart, J.C. Van Loon and H.H. Harvey. 1975. Long term acidification of a lake and resulting effects on fishes. *Ambio* 4:98–102.
- Schindler, D.W., K.H. Mills, D.F. Malley, D.L. Findlay, J.A. Shearer, T.J. Davies, M.A. Turner, G.A. Linsey and D.R. Cruikshank. 1985. Long-term ecosystem stress: The effects of years of experimental acidification on a small lake. *Science* 228:1395–1401.
- Rosseland, B.O. and A. Henriksen. 1990. Acidification in Norway. Loss of fish populations and the 1000-lake survey 1986. *Sci. Total Environ.* 96:45–56.
- Cronan, C.S. and C.L. Schofield. 1979. Aluminium leaching response to acid precipitation: Effects of high elevation watersheds in the Northeast. *Science* 204:304–306.
- Muniz, I.P. and H. Leivestad. 1980. Toxic effects of aluminium on the brown trout, *Salmo trutta*. *Proceedings, International Conference on Ecological Impact of Acid Precipitation*, Sandefjord, Norway, March 11–14, pp. 320–321.
- Howells, G.D., D.J.A. Brown and K. Sadler. 1983. Effects of acidity, calcium and aluminum on fish survival and productivity—A review. *J. Sci. Food Agric.* 34:559–570.
- Playle, R.C., G.G. Goss and C.M. Wood. 1989. Physiological disturbances in rainbow trout (*Salmo gairdneri*) during acid and aluminium exposures in soft water of two calcium concentrations. *Can. J. Zool.* 67:314–324.
- Driscoll, C.T., J.P. Baker, J.J. Bisogni and C.L. Schofield. 1980. Effect of aluminium speciation on fish in dilute acidified waters. *Nature* 284:161–164.
- Witters, H.E., S. Van Puymbroeck, J.H.D. Vangenechten and O.L.J. Vanderborght. 1990. The effect of humic substances on the toxicity of aluminium to adult rainbow trout *Oncorhynchus mykiss* (Walbaum). *J. Fish Biol.* 37:43–53.
- Birchall, J.D., C. Exley, J.S. Chapell and M.J. Phillips. 1989. Acute toxicity of aluminium to fish eliminated in silicon-rich waters. *Nature* 338:146–148.
- Driscoll, C.T. and W.D. Schecher. 1988. Aluminium in the environment. In H. Sigel and A. Sigel, eds., *Metal Ions in Biological Systems. Aluminium and Its Role in Biology*, Vol. 24. Marcel Dekker, New York, NY, USA, pp. 59–122.
- Neville, C.M. and P.G. Campbell. 1988. Possible mechanisms of aluminium toxicity in a dilute acidic environment to fingerlings and older life stages of salmonids. *Water Air Soil Pollut.* 42:311–327.
- Playle, R.L. and C.M. Wood. 1989. Water pH and aluminum chemistry in the gill micro-environment of rainbow trout during acid and aluminum exposures. *J. Comp. Physiol. B* 159:539–550.
- Exley, C., J.S. Chappell and J.D. Birchall. 1991. A mechanism for acute aluminum toxicity in fish. *J. Theor. Biol.* 151:417–428.
- Eeckhaoudt, S. 1994. Morphological and micro-analytical study of gills of fish exposed to aluminum at low pH. Ph.D. thesis. University of Antwerp, Antwerp, Belgium.
- Witters, H.E., S. Van Puymbroeck and O.L.J. Vanderborght. 1991. Adrenergic response to physiological disturbances in rainbow trout, *Oncorhynchus mykiss*, exposed to aluminum at acid pH. *Can. J. Fish Aquat. Sci.* 48:414–420.
- Rosseland, B.O., et al. 1992. The mixing zone between limed and acidic river waters: Complex aluminum chemistry and extreme toxicity for salmonids. *Environ. Pollut.* 78:3–8.
- Lydersen, E. A.B.S. Poléo, M. Nanndrup Petterse, G. Riise, B. Salbu, F. Kroglund and B.O. Rosseland. 1995. The importance of "in situ" measurements to relate toxicity and chemistry in dynamic aluminum freshwater systems. *J. Ecol. Chem.* 3:357–365.
- Lydersen, E., B. Salbu, A.B.S. Poléo and I.P. Muniz. 1990. The influence of temperature on aqueous aluminium chemistry. *Water Air Soil Pollut.* 51:203–215.
- Barnes, R.A. 1975. The determination of specific forms of aluminium in natural water. *Chem. Geol.* 15:177–191.
- Driscoll, C.T. 1984. A procedure for the fractionation of aqueous aluminium in dilute acidic waters. *Int. J. Environ. Anal. Chem.* 16:267–283.
- De Man, A.J.M., J.A. Hofman, T.H. Hendriks, F.M.A. Rosmalen, H.A. Ross and T. Benraad. 1980. A direct radioimmunoassay for plasma aldosterone: Significance of endogenous cortisol. *Neth. J. Med.* 23:79–83.
- Iger, Y., R.A.C. Lock, H.A. Jenner and S.E. Wendelaar Bonga. 1994. Cellular responses in the skin of carp (*Cyprinus carpio*) exposed to copper. *Aquat. Toxicol.* 29:49–64.
- Poléo, A.B.S., E. Lydersen, B.O. Rosseland, F. Kroglund, B. Salbu, R.D. Vogt and A. Kvellestad. 1994. Increased mortality of fish due to changing Al-chemistry of mixing zones between limed streams and acidic tributaries. *Water Air Soil Pollut.* 75:339–351.
- Wood, C.M. 1989. The physiological problems of fish in acid waters. In R. Morris, E.W. Taylor, D.J.A. Brown and J.A. Brown, eds., *Acid Toxicity and Aquatic Animals*. Society for Experimental Biology Seminar Series 34. Cambridge University Press, Cambridge, UK, pp. 125–152.
- Hutchinson, N., K. Holtze, J. Munro and T. Pawson. 1987. Lethal responses of salmonid early life stages to H^+ and Al in dilute waters. *Ann. Soc. R. Zool. Belg.* 117:201–214.
- Oughton, D., B. Salbu and H.E. Bjornstad. 1992. Use of an aluminium-26 tracer to study the deposition of aluminium species on fish gills following mixing of limed and acidic waters. *Analyst* 117:619–621.
- Witters, H.E. 1986. Acute acid exposure of rainbow trout, *Salmo gairdneri* Richardson: Effects of aluminium and calcium on ion balance and haematology. *Aquat. Toxicol.* 8:197–210.
- Verboost, P.M., F.P.J.G. Lafeber, F.A.T. Spanings, E.M. Aarden and S.E. Wendelaar Bonga. 1992. Inhibition of Ca^{2+} uptake in freshwater carp, *Cyprinus carpio* during short-term exposure to aluminium. *J. Exp. Zool.* 262:247–254.
- Iger, Y., H.A. Jenner and S.E. Wendelaar Bonga. 1994. Cellular

- responses in the skin of the trout (*Oncorhynchus mykiss*) exposed to temperature elevation. *J. Fish Biol.* 44:921-935.
31. Iger, Y., R.A.C. Lock, J.C.A. van der Meij and S.E. Wendelaar Bonga. 1994. Effects of waterborne cadmium on the skin of the common carp (*Cyprinus carpio*). *Arch. Environ. Contam. Toxicol.* 26:342-350.
32. Witters, H.E., S. Van Puymbroeck, I. Van Den Sande and O.L.J. Vanderborcht. 1990. Haematological disturbances and osmotic shifts in rainbow trout, *Oncorhynchus mykiss* (Walbaum) under acid and aluminium exposure. *J. Comp. Physiol. B* 160:563-571.
33. Poléo, A.B.S. 1995. Aluminium polymerization—A mechanism of acute toxicity of aqueous aluminium to fish. *Aquat. Toxicol.* 31: 347-356.