

## An Elementary Model of Nitrogen Uptake and Redistribution by Annual Plant Species

N. G. Seligman\*, H. van Keulen, and J. Goudriaan

Department of Theoretical Production Ecology, Agricultural University, Wageningen

Received June 5, 1975

*Summary.* A model is presented that simulates nitrogen uptake and response to nitrogen deficiency by a growing annual plant canopy. It is a descriptive model as it is not based on a detailed definition of the biochemical processes involved. It does incorporate a considerable amount of experimental knowledge about these processes as well as some tentative concepts concerning the availability of soil nitrate and the relation between rates of growth, death and nitrogen translocation to the seeds. The model simulates the effect of nitrogen deficiency on plant growth, seed development, death of vegetative tissues and changes in the nitrogen concentration of the different plant parts. The results warrant a verification and development study under specific field conditions. The model is meant to be used in conjunction with another model that simulates the water balance and transpiration of an annual plant canopy under moisture limiting conditions. The nitrogen balance in the soil is not yet treated in either model.

In most published models of plant canopy growth the supply of water and nutrients to the plant roots is regarded as being non-limiting (de Wit *et al.*, 1970; Lemon *et al.*, 1971). Some models account for limiting soil moisture by means of a reduction function on potential growth (Brockington, 1971; Vickery and Hedges, 1972). One model relates plant growth to transpiration via the water use efficiency which is calculated from another basic plant physiological model or determined experimentally (van Keulen, 1975). Some models account for nitrogen limitation of growth by introducing a reduction function based on "soil nitrogen levels" (Patten, 1972). Only a few have given special attention to nitrogen uptake and its relation to plant growth (Frere *et al.*, 1970; Scaife, 1974).

The present study concerns nitrogen uptake and redistribution in the plant in an elementary model that accounts for much of the available experimental evidence. The model is restricted to annual, seed-forming species with special emphasis on pastures composed of such species growing in semi-arid regions with winter rainfall. In some aspects it is more generally applicable.

Three main processes constitute the core of the present model: nitrogen uptake by the plant; translocation of nitrogen from the vegetative tissue to the seeds; effects of nitrogen levels in the plant on growth and death rates of plant tissue. It is designed for use in conjunction with the model of van Keulen (1975) that relates plant growth to transpiration.

\* Present address: Agricultural Research Organisation, Volcani Center, Bet Dagan, Israel.

## Background

### *a) Nitrogen Uptake by the Plant*

Nitrogen in the nutrient medium can be brought into contact with the root surface by three mechanisms:

- growth of the root to the nutrient source;
- transport to the root with the mass flow of water;
- diffusion along a gradient of decreasing concentration towards the root;

A nitrogen source more than a few centimeters away from an active root is virtually unavailable to the plant unless the root grows towards it. With growth rates of the order of 1 cm day<sup>-1</sup> (Tadmor *et al.*, 1969), this mechanism can be important in adjusting the root system to changes in the location of the source of available nitrogen. This could occur as a result of leaching to lower soil layers for instance. However, a fully expanded root system must be kept in continual supply by mass flow and diffusion.

Mass flow transport can supply the nitrogen needs of the plant only if  $rc > d$  where,

- $r$  = rate of flow of water to the root,
- $c$  = concentration of nitrogen in the water,
- $d$  = demand of nitrogen by the plant.

A closed grass canopy growing at a rate of 200 kg dry matter ha<sup>-1</sup> day<sup>-1</sup> generates a demand of about 8 kg N ha<sup>-1</sup> day<sup>-1</sup>. If transpiration is 4 mm day<sup>-1</sup> then the concentration of nitrogen in the transpiration stream must be at least 200 ppm for the demand to be satisfied by mass flow transport only. Such nitrogen concentrations are seldom attained in the field. For high yielding horticultural crops soil nitrogen concentrations of the order of 80 ppm are considered optimal (Roorda van Eysingen, 1971). However, it is most probable that with high concentrations, osmotic stress will limit water uptake as well as growth (Dijkshoorn and Ismunadji, 1972). In practice this is what limits the amount of nitrogen fertiliser that can be applied to a crop. Thus, mass flow transport cannot normally satisfy such high demands of nitrogen and the difference must be made up by diffusion.

When  $rc < d$ , plant growth can still proceed at potential rates as long as nitrogen is available in the growth medium almost till depletion (Alberda, 1965, 1968). Many experiments (*e.g.* Wiersum, 1973) have shown that the concentration of nitrogen in the transpiration stream can be higher than that in the medium. In water culture the depletion around the root can be prevented by stirring or by convection currents in the solution; but in soil, when  $rc < d$ , depletion of nutrient around the root can be prevented only by diffusion. Theoretical considerations indicate that under such conditions diffusion of anions to the surface of a reasonably dense root system can be so rapid that mass flow is relegated to a minor role (van Keulen *et al.*, 1975). Since most of the available nitrogen in aerated soils is rapidly converted to nitrate by nitrification, this is an important mechanism. Thus, when there is sufficient nitrate in the soil solution, the potential flow rate of nitrate to the root by diffusion is much faster than maximum rates of nitrogen uptake. As a result, the actual uptake rate is controlled by the demand and uptake mechanisms of the plant and is independent of the concentration.

The conclusion that nitrate uptake is independent of its concentration in the medium is apparently contradicted by some experiments (Wild *et al.*, 1974). However, the data can also be interpreted to show that the absolute amount of nutrient available during the growth season and a poorly developed root system were limiting growth. The dependence of uptake on concentration cannot be concluded unequivocally even for the very low concentrations that were used in this experiment.

All three mechanisms, mass flow, diffusion and root growth, operate together and ensure that in a normal, actively growing stand of vegetation, nitrogen is available on demand as long as it is not exhausted in the rooted soil. Availability is reduced by competition from micro-organisms and by leaching beyond the roots. Some aspects of these factors are treated by Beek and Frissel (1973) and by de Wit and van Keulen (1972).

The demand for nitrogen is defined as the difference between the optimum amount of nitrogen in the vegetative tissue of the plant and the actual amount. The uptake rate is equal to the demand divided by a time constant, but cannot be greater than maximum uptake rate, considered in the next paragraph. The time constant converts the demand into a rate and gives an idea of the time needed for the current demand to be satisfied when the plant is well supplied with nitrogen. This is of the order of 2 days.

However, a starved plant takes at least 10 days to restore optimum nitrogen concentration in the tissue, after nitrogen has become freely available again (Dijkshoorn *et al.*, 1968; Dijkshoorn and Ismunadji, 1972). Apparently, the uptake rate necessary to satisfy the excessively high demand of starved plants is beyond the power of the root system. The maximum uptake rate also depends on the amount of transfer tissue available, but no specific study of this aspect has been done. Experimentally, the highest rate of utilization by a closed grass canopy is about 8 kg N ha<sup>-1</sup> day<sup>-1</sup> measured over weekly periods (Sibma, unpublished data). The maximum daily rate of uptake may be a little higher, a maximum of about 9 kg N ha<sup>-1</sup> day<sup>-1</sup> would agree with Dijkshoorn's results.

The optimum level of nitrogen in the tissue needs to be known. Many data (van Burg, 1962; Frere *et al.*, 1970; Houba, 1973) show that even when the supply of nitrogen is adequate, the nitrogen concentration in the whole plant decreases as it matures. When nitrogen is not limiting, the nitrogen level in young leaves stays fairly constant even as the whole plant ages. The decrease in nitrogen concentration of the whole plant is therefore due to an increase in the proportion of structural, nitrogen-poor tissues (van Burg, 1962). The actual values are fairly similar for annual grass and herb species and are usually somewhat higher for legumes. The range in grass and herbs is generally between 4.5% nitrogen in the dry matter of young plants to 2% in mature (van Burg, 1962; Dilz, 1964; Houba, 1972).

#### *b) Translocation of Nitrogen from Vegetative Tissue to Seeds*

The nitrogen concentration in seeds of annual plants varies within a characteristic range for each species (Morrison, 1954; Spector, 1956). The variations within the range are often due to the nitrogen nutrition of the plant (Dilz, 1964). As seeds grow, they utilize stored organic nitrogen from other plant parts. It is

generally accepted that in grasses, nitrate is reduced in the leaves and the nitrogen moves as amino acids to the seeds (McKee, 1962). It has often been shown that when uptake from the growth medium ceases (as a result of depletion or obstruction in the uptake mechanism), the protein nitrogen in the vegetative tissue continues to be mobilised and transferred to the ripening seed; at maturity, the seed can have a much higher nitrogen concentration than the vegetative parts. Growth of the seeds creates a demand for nitrogen which depends on the amount of carbohydrate transferred to the seeds and on their characteristic optimal nitrogen content. The extent to which this demand is satisfied depends on the availability of nitrogen; if it is low, the nitrogen concentration of the seeds is also low (Dilz, 1964). The withdrawal of nitrogen from the vegetative tissue proceeds nevertheless and its nitrogen concentration becomes reduced to very low levels. Values of 0.3% nitrogen in the dry matter of depleted tissues are common (Dilz, 1964).

Little is known about the effect of nitrogen starvation on the translocation of nitrogen to the seed. When nitrogen is available in excess to what the vegetative tissue requires for unrestricted growth, the nitrogen concentration in the seeds should be optimal. When nitrogen drops to a level that limits the rate of photosynthesis, the availability for translocation to the seeds must be severely restricted. The translocation rate must be reduced more drastically than the photosynthesis rate; otherwise there would be no reduction in the concentration of nitrogen in the seeds of nitrogen starved plants. It has been shown that nitrogen supplied to maturing cereal crops can appreciably increase the nitrogen content of the seeds (van Dobben, 1961, 1962, 1965, 1966; Jonker, 1964).

The nitrogen demand of the seeds can be represented as the difference between the optimum and the actual nitrogen content in the seeds; the translocation rate is then the demand divided by a time constant as was postulated for nitrogen uptake by the plant. However, this means that nitrogenous compounds will start to arrive only after the demand has been created by the carbohydrate which diluted the nitrogen in the seed. A lag develops which results in the nitrogen concentration of the seed starting at zero and gradually approaching the optimum concentration at a rate dependent on the magnitude of the time constant.

An alternative representation could link translocation of nitrogenous compounds to the translocation of carbohydrates to the seeds. In this way, the concentration of nitrogen in the seed would be optimum at the start and would drop only if a nitrogen deficiency developed in the tissues. If the nitrogen supply of a starved plant is restored, the nitrogen translocation to the seeds increases accordingly but only in relation to the current carbohydrate transfer. Thus if a nitrogen deficiency develops during only part of the seedfilling stage, the seeds will not attain optimum nitrogen concentration.

In the first representation, nitrogen translocation is controlled by demand in the seed; in the second, by the transfer of carbohydrate to the seed. It is difficult to determine which is more appropriate without additional experimental work.

### *c) Growth of Seeds*

The weight of the seed yield per unit area or per plant will depend on the time available for seed-fill, the rate of photosynthesis during seed-fill, the proportion

of photosynthate translocated to seeds, the number of seeds and the average size of the seed. In many cereal crops grown under normal conditions, size and number of seeds seldom limit seed yield. This can be deduced from data which show that the increase in weight of seed yield accounts for all of the photosynthate formed during the seed filling period (Stoy, 1965; Tanaka *et al.*, 1964; Thorne, 1974). However, if seed formation is prevented by adverse conditions during ear formation or pollination, then seed yield increase will be limited by the small number of seeds and the maximum seed size.

Normally, duration of seed-fill, rate of photosynthesis and partitioning of photosynthate are the dominant factors that determine the yield of seeds. Most annual cultivated seed crops flower and produce seed late in the life of the plant. However, during the period of seed fill, most of the products of net photosynthesis move to the seeds (Stoy, 1965), where their weight is reduced by respiratory losses due to the conversion of carbohydrate to fats and proteins in the seed (Penning de Vries, 1974). In some crops (buckwheat, beans etc.) and in annual mediterranean pastures composed of many wild or recently domesticated species, flower initiation, seed fill and vegetative growth often occur together. Then seed formation generally starts before one third of the life span has passed but a much smaller fraction of the current photosynthate is transferred to the seeds. The actual fraction varies widely between species; judging by seed yields the range is about 10–30%. This fraction can be assumed to be fairly constant as flowering and subsequent seed-fill in these annual species are closely related to leaf and stem development. It has been argued that on theoretical grounds, the fraction should increase; but no supporting evidence is presented (Cohen, 1971).

Current photosynthesis appears to be the main source of carbohydrate for the seeds. Some evidence shows that very little reserve carbohydrate is stored in the vegetative tissues of annual species and even of many perennial species that have no special storage organs. In some experiments, a grass sward used stored carbohydrate for regrowth during the first day after being cut, after which growth depended mainly on current photosynthate (Ryle, 1974). Other experiments have shown that stored carbohydrates are used for regrowth during a number of days after cutting and are important in determining the initial rate of regrowth and consequently, the final yield (Alberda, 1966). Evidence of the immobility of carbohydrate after it has been incorporated into new tissue is given by experiments in which  $^{14}\text{C}$  was fed in pulses to leaves. The assimilated radio-carbon was retained in discrete areas of the roots (Ryle, 1974). However, there is evidence that for certain crops and under certain conditions, carbohydrate stored in the stems can be translocated to the seeds (van Ittersum, 1971; Stoy, 1965; Tanaka *et al.*, 1964). It is estimated that this can account for as much as 20% of seed weight.

#### *d) Nitrogen Levels in the Plant and Their Influence on Growth and Death of Tissues*

There is evidence that maximum growth rates can be maintained even when the nitrogen concentration in the plant is less than maximal. In graminaceous plants, the growth rate does not increase when the nitrate concentration in the foliage is above 0.5 meq/gram dry weight (van Burg, 1962; Dijkshoorn *et al.*, 1968). As nitrogen is exhausted from the medium, the nitrate concentration

becomes very low and the organic nitrogen concentration is reduced as a result of dilution by growth. However, the organic nitrogen level can drop considerably without growth rates being affected (Dijkshoorn *et al.*, 1968). Apparently there is a minimum nitrogen concentration in the plant above which photosynthesis is not seriously limited by nitrogen (Dantuma, 1973). As growth takes place mainly in the younger tissues, both the minimum nitrogen concentration for unrestricted growth and the maximum nitrogen concentration in the plant will drop as it matures and accumulates structural and storage carbohydrates. During the early vegetative phase, the minimum concentration for unrestricted growth of grasses is around 2.0–2.5% N. During the later stages of maturity it drops to around 1.0%. Below the minimum concentration, growth is retarded and eventually ceases when no nitrogen is available for maintenance of the enzyme system of photosynthesis.

The effect of nitrogen in the plant on the death rate is known qualitatively: adequate nitrogen retards the senescence and death of leaves; deficiency hastens it (van Dobben, 1961). With exhaustion of the nitrogen supply to the plant, the nitrogen concentration of the dead leaves becomes very low as most of the nitrogen is mobilized and translocated to the growing parts of the plant (Dilz, 1964). However, a lack of knowledge of the biochemistry of senescence and of more specific empirical data make it difficult to quantify these observations. The normal senescence of leaves depends on the morphogenesis pattern of the plant. These are fairly well known for many crop species, and can be used as a basis for describing leaf death during growth of the canopy.

A quantitative description of the deficiency effect on the death rate can be based on the following considerations. It has frequently been observed that with nitrogen depletion in the plant, net growth is severely reduced before the leaves start to die off. The effect of nitrogen deficiency in the plant on the death rate must initially be weaker than on the growth rate. As the nitrogen concentration drops to a critical value, net growth must cease completely and the death rate must approach a maximum. However, the plant will still manage to form some new tissue at the expense of old (Alberda, 1966).

The effect of nitrogen depletion in the plant on translocation rate of nitrogen to the seeds must be examined in relation to its effect on growth and death rates. In grasses nitrogen is transferred to the seeds as amino acids produced by the leaves. Thus if nitrogen is limiting photosynthesis, the translocation rate of nitrogen to the seeds must drop to a relatively greater extent than the photosynthesis rate. As the nitrogen concentration approaches the level that stops growth, translocation must cease too.

In conclusion, it is proposed that as the nitrogen concentration of the plant drops from the critical level for unrestricted growth to a low, residual level

- the growth rate drops evenly to zero;
- the death rate increases very gradually at first and then rises sharply as the residual level is approached;
- the translocation rate decreases sharply as the critical level is passed.

These relationships are represented in Fig. 1.

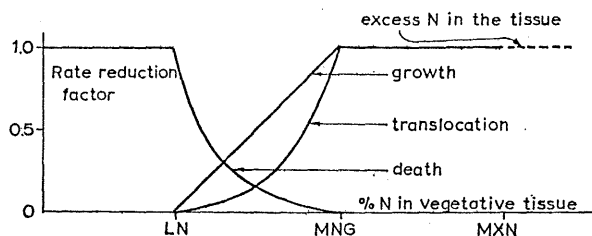

Fig. 1. A schematic representation of the effect of nitrogen concentration in the plant on net growth rate, death rate and the rate of nitrogen translocation to the seeds (*LN* low, residual N-conc. in plant; *MNG* minimum N-conc. needed for unrestricted growth)

#### e) Phenological Aspects

The stages in the life cycle of annual plants considered in this study are germination, vegetative growth, seed-fill and death. The physiological age of the germinating seed and the established plant, which can be represented by the accumulation of development rate in dependence of temperature or sometimes by the accumulation of day degrees (De Wit and Goudriaan, 1974), is generally well correlated with transitions from germination to seedling establishment, from vegetative growth to reproductive growth and from maturity to death. The critical number of day-degrees for each transition is well known for many species, especially cultivated species (*e.g.* Tadmor *et al.*, 1969). The timing of the transitions is also affected by photoperiod, moisture conditions and nutrient status of the plant.

In winter rainfall regions, and in dry regions generally, germination is initiated by wetting of the seed. It can be interrupted if the seed is subsequently dried before seedling emergence and establishment. Under these conditions, the germination of the seeds appears to be relatively insensitive either to temperature thresholds or to photoperiodic and nutrient effects. Seedling emergence generally occurs after a critical number of day-degrees has been accumulated (Tadmor *et al.*, 1969).

Transition from the vegetative to the reproductive stage is a species specific characteristic which is influenced mainly by physiological age (as defined above) and photoperiod (Nuttonson, 1955). In native winter annual species there is no clear transition and both stages occur concurrently. Flowering and seed formation can begin as soon as 30 days after emergence, but normally about 90 days after emergence or after about 900 day-degrees have accumulated. Wheat flowers after about 1300 day-degrees have accumulated. There is evidence that soil moisture stress has very little effect on this transition (Newman, 1965) but nutrient deficiency has a variable effect depending on species, photoperiod and time from germination (Ryle, 1964; Calder and Cooper, 1961). These effects have not yet been considered in the present study as they appear to be relatively small.

The life span of many annuals, especially those of arid environments in many cases is well correlated with the physiological age of the plant. Native species need between 1600–2000 day degrees to mature. Barley is closer to the lower level, wheat to the higher. Moisture and nutrient deficiencies accelerate death rates and shorten the life of the plants. This aspect has been discussed in previous sections.

## The Model

The concepts outlined above were cast in a model written in CSMP (de Wit and Goudriaan, 1974) which will also be used to describe it here. The main structural features of the model are given in Fig. 2. The formulation is adapted for winter growing, annual, non-leguminous species. The season begins on the 1st October; the time units are days.

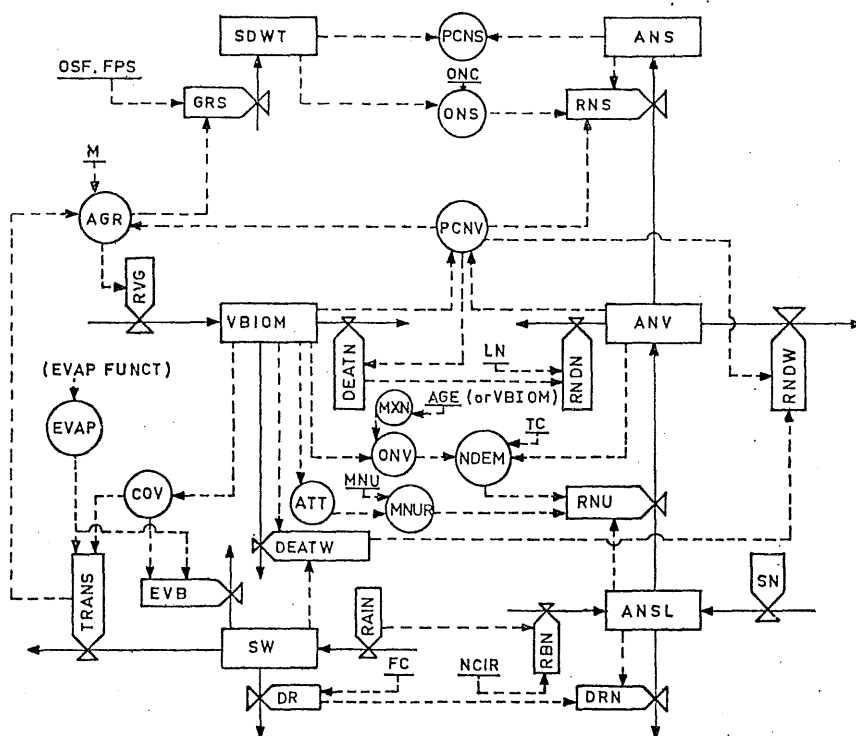

Fig. 2. Main structural features of plant nitrogen model.  $\rightarrow$  flow of material;  $\cdots\rightarrow$  flow of information;  $\square$  state variable;  $\square$  rate of change;  $\circ$  auxiliary variable;  $-$  parameter. *SDWT* seed weight; *PCNS* N-conc. in seed; *ANS* amount of N in seed; *OSF* onset of seed-fill; *FPS* fraction of photosynthate to seeds; *GRS* growth rate of seeds; *ONC* optimum N-conc in seeds; *ONS* optimal amount of N in seeds; *RNS* rate of nitrogen translocation to seeds; *M* proportionality (or transpiration) factor; *AGR* actual total growth rate; *RVG* rate of vegetative growth; *PCNV* N-conc. in vegetative biomass; *VBIOM* vegetative biomass; *DEATN* death rate of *VBIOM* due to N-deficiency; *LN* limiting (residual) N-conc; *RN* rate of N loss to dead plant material due to N-deficiency; *ANV* amount of N in live biomass; *RNDW* rate of N-loss to dead plant material due to water deficiency; *EVAP* potential evaporation; *COV* plant cover; *DEATW* death rate of *VBIOM* due to water deficiency; *ATT* available transfer tissue; *MNU* maximum N-uptake rate per unit of transfer tissue; *MNUR* maximum actual N-uptake rate; *MXN* maximum N-concentration in *VBIOM*; *ONV* maximum N-content of *VBIOM*; *NDEM* N-demand; *TC* time constant ( $\text{TAU}_2$ ); *RNU* rate of N-uptake; *TRANS* transpiration; *EVB* - evaporation from bare soil; *SW* soil water content; *DR* - rate of drainage; *RAIN* precipitation; *FC* field capacity; *NCIR* N-conc in rainfall; *RBN* rain borne N; *ANSL* amount of N in soil; *DRN* loss of N in drainage; *SN* seedling N



a) *The Growth of the Vegetative Biomass and Seed Weight*

Actual Growth Rate of the Vegetative BIOMass is determined by TRANspiration, a proportionality factor ( $M$ ), potential EVAPoration and a reduction factor for nitrogen deficiency ( $X$ ). Growth begins with an Initial BIOMass after germination and is decremented by DEATH due to Water deficiency and DEATH due to Nitrogen deficiency (see section below).

$$VBIOM = INTGRL (0., IBIOM \times PUSH2/DELTA + (RVG-DEATW-DEATN) \times (1-PUSH) - VBIOM \times PUSH/DELTA)$$

$$RVG = (AGR-GRS)$$

$$AGR = GROWTH \times X \text{ (for definition of } X, \text{ see DEATN)}$$

$$GROWTH = M \times TRAN/EVAP$$

$$GRS = INSW (TMPSM-OSF, 0., FPS \times AGR)$$

$$SDWT = INTGRL (0., GRS)$$

$$PARAM OSF = 1300., FPS = 0.8 \text{ (wheat)}$$

PUSH2 is 0 generally, but 1 at the moment of germination. This occurs when the Temperature SUM needed for Germination is reached after a consecutive series of days when soil moisture was above wilting point. There is no germination after the 180th day (end of March). This is programmed as follows:

$$PUSH2 = AND (TMPSM-TSUMG, 0.5 \times IBIOM-VBIOM) \times INSW (TIME-180., 1., 0.)$$

$$TMPSM = INTGRL (0., TMPA-DEAD-TMPSM \times PUSH/DELTA)$$

$$TMPA = TeMPerature of Air, \text{ daily mean in } ^\circ C.$$

$$DEAD = INSW (TSUMG-TMPSM, 0., INSW (SW-WP, TMPSM/DELTA, 0.))$$

Initial BIOMass is a parameter, generally taken here as 50 kg ha<sup>-1</sup>. The term TMPSM/DELTA empties the integral TMPSM whenever the Soil Water drops below Wilting Point. The soil water section is elaborated in a separate program, ARID CROP (van Keulen, 1975).

PUSH is 0 generally, but 1 when VBIOM drops below IBIOM as a result of death rate being more rapid than growth rate. Thus,

$$PUSH = AND (PLBIOM-IBIOM, IBIOM-VBIOM)$$

$$PLBIOM = DELAY (10, DELTA, VBIOM).$$

The term (1.-PUSH) ensures that at the moment all the live vegetation dies, the regular growth and death processes are stopped as well. TRAN and EVAP are calculated in ARID CROP.  $M$  is entered as a table from experimental data or is calculated by means of a physiological process model, BASIC CROP Simulator (de Wit *et al.*, 1975). For trial runs it is set at 120 kg ha<sup>-1</sup> day<sup>-1</sup>. Growth Rate of Seeds is zero before the Onset of Seed-Fill (OSF). For wheat, this would be about 1300 day-degrees after germination, but for many winter annual pasture species, it could be much earlier, sometimes as soon as 600 day-degrees after germination. During wheat seed-fill a large Fraction of the Photosynthate is transferred to the Seeds. In winter annuals, where growth and seed-fill occur simultaneously, the proportion of the photosynthate transferred to the seeds is much smaller, often less than 0.3.

The Dead BIOMass is collected in a separate integral:

$$DBIOM = INTGRL (0., (DEATW + DEATN) \times (1.-PUSH) + VBIOM \times PUSH/DELTA).$$

For definition of DEATW and DEATN see section d) below.

*b) Nitrogen Content of the Vegetation*

The Total Nitrogen in the Vegetative organs is initiated by transfer of Seedling Nitrogen to the integral and then increased by nitrogen uptake at the Rate of Nitrogen Uptake from the growth medium. The amount of nitrogen in the live vegetation drops as the vegetative parts die at a Rate of Nitrogen loss through Death, and as nitrogen is translocated to the seeds (RNS). Thus,

$$\begin{aligned} \text{TNV} &= \text{INTGRL} (0., \text{SN} \times \text{PUSH2/DELTA} + (\text{RNU-RND-RNS}) \times (1.-\text{PUSH})) \\ \text{SN} &= \text{IBIOM} \times \text{MXN} [\text{MXN}(\text{see section c})]. \end{aligned}$$

*c) Rate of Nitrogen Uptake*

Nitrogen DEMand is determined by the nitrogen deficiency in the plant (Optimum amount of Nitrogen in Vegetation minus actual Total amount of Nitrogen in Vegetation) divided by a time constant which converts nitrogen deficit to a rate.

Thus,

$$\begin{aligned} \text{NDEM} &= (\text{ONV-TNV})/\text{TAU2} \\ \text{ONV} &= \text{VBIOM} \times \text{MXN}. \end{aligned}$$

TAU2 has arbitrarily been set at 2 days on the assumption that uptake responds rapidly to need, in any case within 2 days. As long as there is Available Nitrogen in the Soil, the demand will be satisfied, irrespective of concentration of nitrogen (van Keulen *et al.*, 1975). However, no more can be removed than what is available and the rate of uptake cannot exceed a Maximum Nitrogen Uptake Rate.

Maximum Nitrogen concentration (actually optimum conc.) of the vegetation drops between germination and the end of the growing season as a function of physiological age. Thus when net increase in dry matter is restricted by moisture deficiency, the plant will still develop structural and reproductive organs and the optimum nitrogen level will drop to similar levels that are attained when crop growth is more vigorous. However, a good case could be made for having the optimum nitrogen level dependent on the biomass. If it is seen as age dependent, the simplest representation would be:

$$\begin{aligned} \text{MX} &= (1.-\text{TMPSM/EGRTH}) \times 0.025 + 0.02 \\ \text{MXN} &= \text{LIMIT} (0.02, 0.045, \text{MX}) \end{aligned}$$

which makes MXN drop from 0.045 g nitrogen per g dry matter on germination to 0.02 g g<sup>-1</sup> at the End of the GRowTH season as the sum of day-degrees (TMPSM) increases.

EGRTH is a parameter which represents the number of day-degrees beyond which growth does not occur. Under the given conditions it is taken as 2300.

If it is preferred to have MXN dependent on biomass then the following values would be analogous to the age dependent MXN:

$$\text{MXN} = \text{AFGEN} (\text{MXNT}, \text{VBIOM})$$

$$\text{FUNCTION MXNT} = 0., 0.045, 2000, 0.03, 6000., 0.025, 10000., 0.02$$

A consequence of this alternative is an increase in MXN as live plant biomass is reduced due to dying or grazing. This implies that older tissues are removed first, a reasonable assumption for dying plants in most cases, but not for grazed plants.

The amount of Nitrogen in the Soil is discussed in section f) below.

The Maximum Nitrogen Uptake Rate is dependent on the Amount of Transfer Tissue available. This is represented as a function of VBIOM as is done in the calculation of plant cover in ARID CROP. The parameter CF is taken as lower than what is used to calculate LAI in ARID CROP. The reason is that the transfer tissue includes roots, the horizontal extension of which is probably greater than the canopy cover, especially when VBIOM is low. Thus, the Rate of Nitrogen Uptake equals:

$$\begin{aligned} \text{RNU} &= \text{AMIN1 (NDEM, ANSL/DELT, MNUR)} \\ \text{MNUR} &= \text{MNU} \times \text{ATT} \\ \text{PARAM MNU} &= 9 \text{ (kg N ha}^{-1} \text{ day}^{-1}\text{)} \\ \text{ATT} &= 1. - \text{EXP} (-0.5 \times \text{TTD}) \\ \text{TTD} &= \text{VBIOM/CF} \\ \text{PARAM CF} &= 350. \end{aligned}$$

*d) Rate of Nitrogen Loss through Death of Vegetation*

Two cases of death of plant tissue are considered; soil water deficiency and nitrogen deficiency (Ageing and senescence are taken into account in the ARID CROP model referred to previously). Nitrogen loss is different in the two cases. Rate of Nitrogen loss by Death due to Water deficiency is determined by DEATW and by the concentration of nitrogen in the live vegetative biomass (PCNV). However, the Rate of Nitrogen loss by Death due to Nitrogen deficiency is determined by DEATN and the residual or Limiting conc. of Nitrogen in the plant. The reasoning behind this distinction is that a tissue dies from nitrogen deficiency after it has been depleted of nitrogen by other living tissue; whereas a tissue that dies due to moisture deficiency must die with an average nitrogen content. Otherwise the concentration of nitrogen in the remaining living tissue would rise explosively.

$$\begin{aligned} \text{RNDW} &= \text{DEATW} \times \text{PCNV} \\ \text{PCNV} &= \text{TNV/VBIOM} \end{aligned}$$

The relative death rate of vegetative biomass due to water deficiency (FDEATH) is a function of soil moisture conc. (PSI). Wilting point is at PSI=0.2.

$$\begin{aligned} \text{DEATW} &= \text{VBIOM} \times \text{FDEATH} \\ \text{FDEATH} &= \text{AFGEN (FDT, PSI)} \\ \text{FUNCTION FDT} &= 0.0, 0.5, 0.09, 0.5, 0.1, 0.03, 0.25, 0., 1.0, 0.0 \\ \text{PSI} &= \text{SW/FC} \end{aligned}$$

FC is a parameter, here 200 mm. Soil Water is calculated by ARID CROP.

$$\begin{aligned} \text{RNDN} &= \text{DEATN} \times \text{LN1} \\ \text{DEATN} &= \text{VBIOM} \times \text{DRND} \\ \text{LN1} &= \text{AMIN1 (LN, PCNV)} \end{aligned}$$

LN is a parameter, here set at 0.005. The relative Death Rate of live biomass due to Nitrogen Deficiency (DRND) increases slowly as PCNV drops below the Minimum Nitrogen concentration for unrestricted Growth and then rapidly to an estimated maximum of 0.3 day<sup>-1</sup> as PCNV approaches LN. This can be entered as a table or as a quarter circle, which is a sufficient approximation for the present (see Fig. 3).

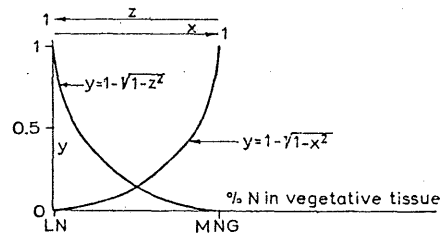

Fig. 3. Circular reduction functions for representing the relationship between N-concentration in VBIOM and various process rates

$$DRND = 0.3 \times (1 - \text{SQRT}(1 - Z \times Z)) \quad (\text{Death Rate due to Nitrogen Deficiency})$$

$$Z = 1 - X \quad (\text{see Fig. 3})$$

$$X = (\text{LIMIT}(\text{LN}, \text{MNG}, \text{PCNV}) - \text{LN}) / (\text{MNG} - \text{LN})$$

$$\text{MN} = (1 - \text{TMPSM} / \text{EGRTH}) \times 0.015 + 0.01$$

$$\text{MNG} = \text{LIMIT}(0.010, 0.025, \text{MN})$$

The discussion on MXN applies equally to MNG.

#### e) Rate of Nitrogen Translocation to the Seeds

This is made dependent on the demand for nitrogen created by the growing seeds, a time constant and a reduction factor for nitrogen depletion in the plant. It serves to reduce the translocation rate drastically as the PCNV drops below MNG. Thus the Rate of Nitrogen transportation to the seeds is:

$$\text{RNS} = (\text{ONS} - \text{ANS}) / \text{TAU} \times 2 \times \text{NDEF}$$

$$\text{NDEF} = 1 - \text{SQRT}(1 - X \times X) \quad (\text{see Fig. 3}) \quad (\text{Nitrogen DEFiciency Factor})$$

$$\text{ONS} = \text{SDWT} \times \text{ONC} \quad (\text{Optimum Nitrogen in the Seed})$$

$$\text{ONC is a parameter, set here at 0.025.} \quad (\text{Optimum Nitrogen Conc. in the seed})$$

$$\text{ANS} = \text{INTGRL}(0., \text{RNS}) \quad (\text{Amount of Nitrogen in Seeds})$$

RNS need not necessarily be determined by the demand created by the nitrogen deficit in the seeds. It could be related to the translocation of carbohydrate from the leaf to the seed. The translocation rate would then be reduced by nitrogen deficiency in the vegetative parts as above.

$$\text{RNS} = \text{GRS} \times \text{ONC} \times \text{NDEF}.$$

#### f) The Amount of Nitrogen in the Soil

The nitrogen balance in the soil is not fully considered in this model as the emphasis is on the plant. The available nitrogen is seen to be a fertiliser application which can be varied as a parameter, SI. It is then decremented at a rate determined by the Rate of Nitrogen Uptake by the plant and by loss through DRainage of Nitrogen beyond the root system. In this case, Field Capacity is set at 200 mm soil water. The effect of micro-organisms on the availability of nitrogen is not treated in the present model (see Beek and Frissel, 1973).

$$\text{ANSL} = \text{INTGRL}(\text{SI}, -\text{RNU} - \text{DRN})$$

$$\text{DRN} = \text{DRXSWNC}$$

$$\text{SWNC} = \text{ANSL} / \text{SW}$$

$$\text{DR} = \text{AMAX1}(0., \text{SW} - \text{FC}) / \text{DELT}$$

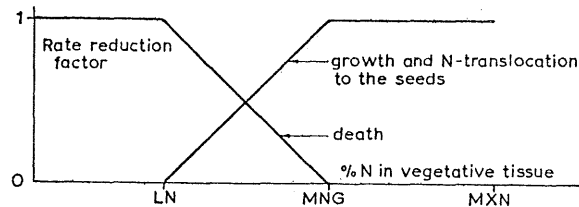

Fig. 4. Linear reduction functions for representing the relationship between N-concentration in VBIOM and growth rate, nitrogen translocation rate to seeds, and death rate of VBIOM

For some runs, Rain Borne Nitrogen was added; in which case the Amount of Nitrogen in the Soil is

$$\text{ANSL} = \text{INTGRL}(\text{SI}, -\text{RNU} - \text{DRN} + \text{RBN})$$

$$\text{RBN} = \text{RAIN} \times \text{NCIR}$$

Nitrogen Content In Rain is a parameter and set at  $0.01\text{--}0.025 \text{ kg N mm}^{-1}$  or  $1.0\text{--}2.5 \text{ ppm}$  (Low and Armitage, 1970).

## Results

### a) Functional Form of Reduction Factors

The model was run to determine the influence of some functions and parameters on various output variables. The influence of the type of reduction function due to increasing nitrogen deficiency on growth rate, death rate and translocation rate of nitrogen to the seed was examined. As a test crop wheat was used. Two sets of suppositions were compared. The one, A, that the reduction factors are linearly related to nitrogen deficiency (Fig. 4) and the other, B, that the relationship is non-linear, as described in the model above (Fig. 1).

In order to run these tests, simplified driving variables were defined for rainfall and potential evaporation: a shower every 15 days in winter and spring according to a sinusoidal function gave a total rainfall of ca.  $300 \text{ mm year}^{-1}$ ; potential evaporation varied sinusoidally from a minimum of  $2 \text{ mm day}^{-1}$  in mid-winter to 6 in mid-summer. Actual transpiration was calculated as a function of cover, soil moisture content and potential evaporation; evaporation from bare soil was a quarter of transpiration per unit area. Cover was calculated as a function of VBIOM.

The results for various amounts of available nitrogen in the soil are given in Table 1.

The calculated total production values with  $100 \text{ kg}$  of available nitrogen  $\text{ha}^{-1}$  are close to what has been measured under these rainfall conditions (van Keulen, 1975). It is clear that total dry matter production is not very sensitive to the exact nature of the tested functions for all levels of nitrogen availability. There is a small effect on the partitioning of assimilates between seeds and vegetative biomass. The linear functions result in a somewhat shorter growing season but the differences between the nitrogen levels are equally pronounced with the non-linear functions. (In both cases the growing season for  $\text{SI} = 100$  is exaggerated because in these runs the ageing of the crop was not included.) The only important

Table 1. The effect of different response functions to nitrogen deficiency in the plant for growth, death and translocation rates on biomass production and nitrogen status of wheat at the end of the simulated growing season

| Type of response function | SI<br>kg N<br>ha <sup>-1</sup> | VBIOM<br>(max)<br>kg DM<br>ha <sup>-1</sup> | SDWT<br>kg DM<br>ha <sup>-1</sup> | DBIOM<br>kg DM<br>ha <sup>-1</sup> | Total<br>biomass<br>kg DM<br>ha <sup>-1</sup> | End of<br>season<br>day | Nitrogen<br>in seed<br>% | Nitrogen<br>whole<br>plant<br>% | Nitrogen<br>in dead<br>biomass<br>% |
|---------------------------|--------------------------------|---|-----------------------------------|------------------------------------|---|-------------------------|--------------------------|---------------------------------|-------------------------------------|
| A<br>(linear)             | 100                            | 3347  | 2452                              | 4573                               | 7025  | 215                     | 2.5                      | 1.4                             | 0.56                                |
|                           | 50                             | 2725  | 1030                              | 3625                               | 4655  | 186                     | 2.4                      | 1.1                             | 0.72                                |
|                           | 20                             | 1126  | 236                               | 2387                               | 2623  | 172                     | 2.3                      | 0.8                             | 0.66                                |
|                           | 5                              | 264   | 27                                | 807                                | 834   | 162                     | 2.1                      | 0.7                             | 0.69                                |
| B<br>(non<br>linear)      | 100                            | 3347  | 2538                              | 4676                               | 7214  | 237                     | 2.35                     | 1.4                             | 0.87                                |
|                           | 50                             | 2839  | 1275                              | 3788                               | 5063  | 207                     | 1.85                     | 1.0                             | 0.73                                |
|                           | 20                             | 1401  | 402                               | 2430                               | 2832  | 192                     | 1.24                     | 0.75                            | 0.66                                |
|                           | 5                              | 340   | 54                                | 818                                | 872   | 177                     | 1.0                      | 0.7                             | 0.68                                |

Table 2. Nitrogen content of grain grown at different levels of nitrogen availability (N0 = no nitrogen fertilizer; N3 = heavy nitrogen fertilizer application)

| Nitrogen<br>availability | Nitrogen content of grain (% N of dry matter) |               |                  |                 |
|--------------------------|---|---------------|------------------|-----------------|
|                          | Oats  | Summer<br>rye | Summer<br>barley | Summer<br>wheat |
| N0                       | 1.22  | 1.39          | 1.32             | 1.4             |
| N1                       | 1.88  | 1.80          | 2.0              | 2.14            |
| N2                       | 1.95  | 1.98          | 1.99             | 2.11            |
| N3                       | 2.4   | 2.25          | 2.35             | 2.57            |

difference is in the nitrogen content of the seeds. This drops with decreasing nitrogen availability in both cases, but the drop is very slight with the linear functions. The pronounced drop obtained with the non-linear functions is more in keeping with experimental data. An example is given in Table 2, calculated from the results of Dilz (1964, p. 76).

The trend and the range of all the cereals are well reproduced by the simulation program, especially when one considers that SI = 5 implies an extremely nitrogen-poor situation. SI = 20 is probably closer to the control (N0) situation of Dilz.

The straw to seed ratio drops with increasing available nitrogen from 15.1 to 1.8 (Table 1B). This is more or less in accordance with most observations but there are also cases where the ratio increases again with a further increase of available nitrogen. Such an effect would not be reflected by the present model.

#### *b) Effect of Rain-Borne Nitrogen on Production*

Nitrogen concentration of rainfall varies widely but is generally between 1 to 2.5 ppm (Low and Armitage, 1970). As it becomes available during the season (unlike fertilizer nitrogen which is immediately available at the beginning) it may be of considerable importance in maintaining growth towards the end of the

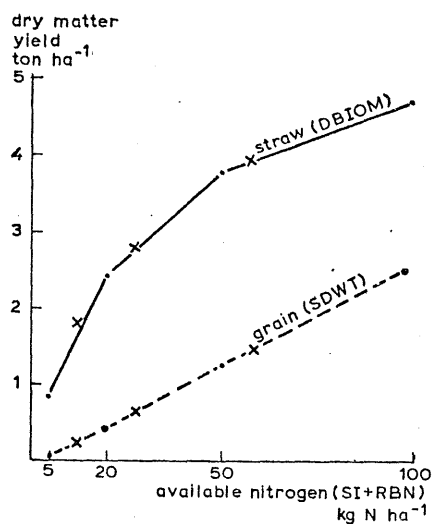

Fig. 5. Effect of initial amounts of available nitrogen in the soil and rain-borne nitrogen on growth of vegetative biomass and grain yield of wheat, without (•) and with (x) rain-borne nitrogen (2.5 ppm N  $\approx$  7.5 kg N ha<sup>-1</sup>)

Table 3. Effect of rain-borne nitrogen on length of growing season of wheat (days)

| SI  | Nitrogen content of the rain |       |         |
|-----|------------------------------|-------|---------|
|     | 0 ppm                        | 1 ppm | 2.5 ppm |
| 100 | 237                          | 239   | 243     |
| 50  | 207                          | 209   | 211     |
| 20  | 192                          | 194   | 197     |
| 5   | 177                          | 184   | 189     |

season. The 7.5 kg N ha<sup>-1</sup> that 2.5 ppm in 300 mm of rainfall would provide may be more effective than a similar amount given as a single dressing at the beginning of growth. The results for seed weight and straw weight are given in Fig. 5. These indicate that under these conditions nitrogen in the rainfall acts as an increment of available nitrogen because the response to the additional nitrogen coincides with the response curve for nitrogen applied at the beginning of the season.

The effect of the rain-borne nitrogen on growth duration is usually minimal for all intents and purposes but when very little nitrogen is available, it lengthens the growing season by 7 to 12 days (Table 3).

The end of the growing season is defined as the day when the last remnant of live vegetative biomass dies. It is interesting that even with the low rainfall used in this model (less than 300 mm for the whole season) the crop died mainly because of nitrogen deficiency and only to a much lesser extent because of lack of moisture. Nitrogen was limiting growth even when 100 kg N was available at the beginning of the season.

Table 4. Effect of time constant on dry matter production and seed-yield of wheat

| Nitrogen availability<br>kg N ha <sup>-1</sup> | Value of time constant<br>TAU2<br>day | SDWT<br>kg DM<br>ha <sup>-1</sup> | DBIOM<br>kg DM<br>ha <sup>-1</sup> | Total biomass<br>kg DM<br>ha <sup>-1</sup> | End of season<br>day | N in seed<br>% | N in whole plant<br>% | N in dead veg.<br>material<br>% |
|--|---------------------------------------|-----------------------------------|------------------------------------|--|----------------------|----------------|-----------------------|---------------------------------|
| 50   | 2                                     | 1188                              | 2831                               | 4019                                       | 204                  | 2.5            | 1.2                   | 0.70                            |
|  | 5                                     | 1213                              | 2890                               | 4103                                       | 201                  | 2.4            | 1.2                   | 0.70                            |
|  | 10                                    | 1274                              | 3031                               | 4305                                       | 203                  | 2.2            | 1.1                   | 0.70                            |
| 20   | 2                                     | 497                               | 1217                               | 1714                                       | 178                  | 2.5            | 1.2                   | 0.71                            |
|  | 5                                     | 511                               | 1251                               | 1762                                       | 172                  | 2.4            | 1.2                   | 0.71                            |
|  | 10                                    | 547                               | 1336                               | 1883                                       | 173                  | 2.1            | 1.1                   | 0.71                            |
| 5  | 2                                     | 125                               | 350                                | 475  | 146                  | 2.5            | 1.3                   | 0.86                            |
|  | 5                                     | 129                               | 359                                | 488  | 144                  | 2.4            | 1.3                   | 0.85                            |
|  | 10                                    | 139                               | 382                                | 521  | 145                  | 2.1            | 1.2                   | 0.84                            |

*c) The Effect on Growth of Different Time Constants for Nitrogen Uptake and Translocation*

The time constant TAU2 was set at 2 days for both uptake and translocation. As this determines the rate of the processes it is reasonable to suppose that it would influence growth and seed production. Some results with different values for TAU2 are given in Table 4.

From these data it is clear that the results are virtually insensitive to the time constant of nitrogen uptake and translocation and only the amount available determines the final yield. The slightly higher yields with the higher time constant are accompanied by lower nitrogen levels in the seed. The delay in translocation due to a higher time constant reduced the death rate due to nitrogen deficiency and as a result increased yields. But this is a small effect and it must be concluded that in a model with this structure the time constants for nitrogen uptake and translocation need not be accurately defined.

*d) Growth of Mixed Annual Vegetation*

The plant species in this model is defined only by two explicit parameters, the time at which seed-fill begins and the fraction of net weight increase that is transferred to the seeds after seed-fill has begun. Implicitly, the model assumes that the species are winter growing annuals. The proportionality factor, M, is not considered here as species dependent but it could be. The wheat was defined by starting seed-fill after 1300 day-degrees had accumulated (about the 105th day after germination) and by transferring 0.6 of the growth to the seeds (This should have been higher, probably around 0.8. But it is unlikely that it would have increased seed yield very much as more rapid depletion of nitrogen would have resulted in earlier plant death). Natural winter annual vegetation is then defined as beginning seed-fill much earlier, after 400 day-degrees had accumulated (about the 30th day after germination) but only transferring 0.3 of the current growth to the seeds. Thus vegetative growth and seed formation are concurrent, as observed. Results for different amounts of available nitrogen are given in Table 5.



Table 5. Effect of nitrogen availability on the yield of seed and straw in a mixed annual winter sward (non-linear reduction functions)

| Nitrogen avail-ability<br>kg N ha <sup>-1</sup> | SDWT<br>kg DM<br>ha <sup>-1</sup> | DBIOM<br>(straw)<br>kg DM<br>ha <sup>-1</sup> | Total<br>biomass<br>kg DM<br>ha <sup>-1</sup> | End<br>of<br>season<br>day | Nitrogen<br>in<br>seed<br>% | Nitrogen<br>in<br>whole<br>plant<br>% | Nitrogen<br>in dead<br>biomass<br>% |
|---|-----------------------------------|---|---|----------------------------|-----------------------------|---------------------------------------|-------------------------------------|
| 100   | 1875                              | 4368  | 6243  | 270                        | 2.5                         | 1.4                                   | 1.0                                 |
| 50  | 1262                              | 3009  | 4271  | 222                        | 2.2                         | 1.1                                   | 0.7                                 |
| 20  | 552                               | 1345  | 1897  | 191                        | 2.1                         | 1.1                                   | 0.7                                 |
| 5   | 143                               | 393   | 536   | 157                        | 2.0                         | 1.1                                   | 0.8                                 |

Compared with a cultivated winter cereal (Table 1 B) the total yield is lower at all levels of available nitrogen. However, seed yields are lower only at the high levels. The reason is that as seed-fill begins earlier, the seeds grow before available soil nitrogen is depleted by the vegetative growth. This result is similar, at least qualitatively, to what one finds in the field. This phenomenon has been described as an adaptation to moisture limitation in semi-arid conditions (Cohen, 1971). Could early flowering with concurrent vegetative and reproductive stages also be an adaptation to limited amounts of available soil nitrogen? It has already been pointed out above that even under semi-arid conditions ( $\approx 300$  mm precipitation year<sup>-1</sup>) low nitrogen levels can limit growth more than limited available soil moisture.

*Acknowledgments.* Prof. Dr. Ir. C. T. de Wit participated actively in this study with advice and criticism. Dr. W. Dijkshoorn, Dr. Th. Alberda of I.B.S., Wageningen, and Dr. I. Noy-Meir of the Hebrew University of Jerusalem read the draft MS. Their comments, corrections, and suggestions have been incorporated in this revised version.

The study is part of a joint project on plant growth in semi-arid winter rainfall regions conducted by the following institutions: Department of Theoretical Production Ecology, Agricultural University, Wageningen; I. B. S., Wageningen; the Botany Department of the Hebrew University of Jerusalem; Agricultural Research Organization, Volcani Center, Bet Dagan, Israel. The project was partly financed by the D. T. H., the Hague.

### References

- Alberda, Th.: The influence of temperature, light intensity and nitrate concentration on dry matter production and chemical composition of *Lolium perenne* L. Neth. J. agric. Sci. **13**, 335-360 (1965)
- Alberda, Th.: The influence of reserve substances on dry matter production after defoliation. Proc. X Int. Grassl. Congr., pp. 140-147 (1966)
- Alberda, Th.: Some aspects of nitrogen in plants, more especially in grass. Stikstof **7**, 97-103 (1968)
- Beek, J., Frissel, M. J.: Simulation of nitrogen behaviour in soils. Simulation Monographs, No. 2. Wageningen: PUDOC 1973
- Brockington, N. R.: Using models in agricultural research. Span **14**, 1-4 (1971)
- van Burg, P. F. J.: Internal nitrogen balance, production of dry matter and ageing of herbage and grass. D. Agr. Sci. Thesis, Agricultural University, Wageningen, Agric. Res. Report, No. 68.12 (1962)
- Calder, D. M., Cooper, J. P.: Effect of spacing and nitrogen level on floral initiation in cocksfoot (*Dactylis glomerata*, L.). Nature (Lond.) **191**, 195-196 (1961)

- Cohen, D.: Maximising final yield when growth is limited by time or by limiting resources. *J. theor. Biol.* **33**, 299-307 (1971)
- Dantuma, G.: Photosynthesis in leaves of wheat and barley varieties. *Neth. J. agric. Sci.* **21**, 188-198 (1973)
- Dijkshoorn, W.: Nitrate accumulation, nitrogen balance and cation-anion ratio during the regrowth of perennial rye-grass. *Neth. J. agric. Sci.* **6**, 211-221 (1958)
- Dijkshoorn, W.: Partitioning of ionic constituents between organs. *Proc. 6th Int. Colloq. on Plant Anal. and Fert. Problems*, Tel Aviv, p. 447-476 (1970)
- Dijkshoorn, W., Ismunadji, M.: Nitrogen nutrition of rice plants measured by growth and nutrient content in pot experiments. 3. Changes during growth. *Neth. J. agric. Sci.* **20**, 133-144 (1972)
- Dijkshoorn, W., Lathwell, D. J., de Wit, C. T.: Temporal changes in carboxylate content of ryegrass with stepwise change in nutrition. *Plant and Soil* **29**, 369-390 (1968)
- Dilz, K.: On the optimum nitrogen nutrition of cereals. *D. Agr. Sci. Thesis*, Agricultural University, Wageningen, Agric. Res. Report 641 (1964)
- van Dobben, W. H.: Nitrogen uptake of spring wheat and poppies in relation to growth and development. *Med. 154*, in *Jaarboek IBS 1961*, p. 45-60. Wageningen: I.B.S. 1961
- van Dobben, W. H.: The distribution of dry matter in cereals and grasses in relation to nitrogen nutrition. *Mededeling 183*, in *Jaarboek IBS 1962*, p. 77-139. Wageningen: I.B.S. 1962
- van Dobben, W. H.: Recent views in the field of nitrogen fertilisation of rye in Western Europe. *Mededeling 287*, in *Jaarboek IBS 1965*, p. 75-80. Wageningen: I.B.S. 1965
- van Dobben, W. H.: Systems of management of cereals for improved yield and quality. In: *Growth of grasses and cereals*, F. L. Milthorpe, J. D. Ivins, eds. London: Butterworths 1966
- Frere, M. H., Jensen, M. E., Carter, J. N.: Simulation of nitrogen behaviour in the soil-plant system. *Proceedings 1970, Summer computer simulation conference*. Denver, Colorado, sponsored by ACM/SHARE/Sci., vol. II (1970)
- Houba, V. J. G.: Effect of nitrogen dressings on growth and development of sugarbeet. *D. Agr. Thesis*, Agricultural University, Wageningen, Agric. Res. Report 791 (1973)
- van Ittersum, A.: A calculation of potential rice yields. *Neth. J. agric. Sci.* **19**, 10-21 (1971)
- Jonker, J. J.: De stikstofbemesting van granen in de IJsselmeerpolders. *Stikstof 42*, 206-212 (1964)
- van Keulen, H.: Simulation of water use and herbage growth in arid regions. *Simulation Monographs*. Wageningen: PUDOC 1975
- van Keulen, H., Seligman, N. G., Goudriaan, J.: Availability of anions in the growth medium to roots of an actively growing plant. *Neth. J. agric. Sci.* (in press)
- Lemon, E. R., Stewart, D. W., Shavercroft, R. W.: The sun's work in a cornfield. *Science* **174**, 371-378 (1971)
- Low, A. J., Armitage, E. R.: The comparison of leachate through cropped and uncropped soils in lysimeter compared with that of rain. *Plant and Soil* **33**, 393-411 (1970)
- McKee, H. S.: *Nitrogen metabolism in plants*, pp. 728. Oxford: Clarendon Press 1962
- Morrison, F. B.: *Feeds and feeding*, 21st ed., 1207 pp. New York: The Morrison Publishing Company 1954
- Newman, E. I.: Factors affecting the seed production of *Teesdalia nudicaulis*. II. Soil moisture in spring. *J. Ecol.* **53**, 211-232 (1965)
- Nuttonson, M. Y.: Wheat-climate relationship and the use of phenology in ascertaining the thermal and photo-thermal requirements of wheat. Washington, D. C.: Am. Inst. Crop. Ecol. 1955
- Patten, B. C.: A simulation of the short-grass prairie ecosystem. *Simulation* **16**, 177-186 (1972)
- Penning de Vries, F. W. T.: Substrate utilization and respiration in relation to growth and maintenance in higher plants. *Neth. J. agric. Sci.* **22**, 40-44 (1974)
- Roorda van Eysinga, J. P. N. L.: Fertilisation of tomatoes with nitrogen. *Agric. Res. Rep.* **754**. Wageningen: PUDOC 1971
- Scaife, M. A.: Computer simulation of nitrogen uptake and growth. *Proceedings 7th Int. Colloquium on Plant Analysis and Fertiliser Problems*, Hannover, Vol II, p. 413-436 (1974)
- Scott-Russell, R., Shorrocks, V. M.: The relationship between transpiration and the absorption of organic ions by intact plants. *J. expt. Bot.* **10**, 301-316 (1959)

- Sibma, L.: Unpublished data. Wageningen: I. B. S. 1974
- Stoy, V.: Photosynthesis, respiration and carbohydrate accumulation in spring wheat in relation to yield. *Phys. Plant., Suppl. IV*, Lund, Sweden (1965)
- Tadmor, N. H., Hillel, D., Cohen, Y.: Establishment and maintenance of seeded dryland range under semi-arid conditions. Final report, project A 10-CR-45, submitted to USDA, p. 140 (1969)
- Tanaka, A., Navasero, S. A., Garcia, C. V., Parao, F. T., Raminez, E.: Growth habit of the rice plant in the tropics and its effect on nitrogen response. *Techn. Bull. 3*, IRRI, Philippines (1964)
- Thorne, G.: Personal communication (1974)
- Vickery, P. J., Hedges, D. A.: A productivity model of improved pasture grazed by merino sheep. *Proc. Austr. Soc. Anim. Prod.* **9**, 16-22 (1972)
- Wiersum, L. K.: Some experiments on supply of ions to the absorbing root surface. *Neth. J. agric. Sci.* **21**, 263-268 (1973)
- Wild, A., Skarlou, V., Clemen, C. R., Snaydon, R. W.: Comparison of potassium uptake by four plant species grown in sand and flowing solution culture. *J. appl. Ecol.* **11**, 801-812 (1974)
- de Wit, C. T., Brouwer, R., Penning de Vries, F. W. T.: The simulation of photosynthetic systems. In: Prediction and Measurement of photosynthetic productivity. Proc. of the IBP/PP Technical Meeting, Trebon, September 1969, p. 47-70 (1970)
- de Wit, C. T., Dijkshoorn, W., Noggle, J. C.: Ionic balance and growth of plants. *Versl. Landbouwk. Onderz.* **69.15**, Mededeling 220. Wageningen: I. B. S. 1963
- de Wit, C. T., Goudriaan, J.: Simulation of ecological processes. Simulation Monographs no. 4. Wageningen: PUDOC 1974
- de Wit, C. T., van Keulen H.: Simulation of transport processes in soils. Simulation Monographs No. 1. Wageningen: PUDOC 1972
- de Wit, C. T., Penning de Vries, F. W. T., Goudriaan, J., van Keulen. H.: BACROS, a basic crop simulator. Simulation Monographs. Wageningen: PUDOC 1975 (in preparation)

Dr. N. G. Seligman  
Agricultural Research Organisation  
Volcani Center  
Bet Dagan, Israel

