



Efficient generation of 509 nm light by sumfrequency mixing between two tapered diode lasers

Tawfieq, Mahmoud; Jensen, Ole Bjarlin; Hansen, Anders Kragh; Sumf, Bernd; Andersen, Peter E.

Publication date:
2014

Document Version
Publisher's PDF, also known as Version of record

[Link back to DTU Orbit](#)

Citation (APA):

Tawfieq, M., Jensen, O. B., Hansen, A. K., Sumf, B., & Andersen, P. E. (2014). Efficient generation of 509 nm light by sumfrequency mixing between two tapered diode lasers. Poster session presented at 10th International Young Scientist Conference , Riga, Latvia.

DTU Library

Technical Information Center of Denmark

General rights

Copyright and moral rights for the publications made accessible in the public portal are retained by the authors and/or other copyright owners and it is a condition of accessing publications that users recognise and abide by the legal requirements associated with these rights.

- Users may download and print one copy of any publication from the public portal for the purpose of private study or research.
- You may not further distribute the material or use it for any profit-making activity or commercial gain
- You may freely distribute the URL identifying the publication in the public portal

If you believe that this document breaches copyright please contact us providing details, and we will remove access to the work immediately and investigate your claim.

Efficient Generation of 509 nm Light by Sum-Frequency Mixing between two Tapered Diode Lasers



Mahmoud Tawfiq^{1,*}, Ole Bjarlin Jensen¹, Anders Kragh Hansen¹, Bernd Sumpf² and Peter E. Andersen¹

¹DTU Fotonik, Department of Photonics Engineering, Technical University of Denmark, Frederiksborgvej 399, 4000 Roskilde, Denmark

²Ferdinand-Braun-Institut, Leibniz-Institut für Höchstfrequenztechnik, Gustav-Kirchhoff-straße 4, 12389 Berlin, Germany

*s093016@student.dtu.dk

Introduction

Many applications within the field of biomedicine, material processing and displays require light sources in the visible region. The green spectral region is not easily accessible by direct diode lasers, and therefore several methods exist for generation of green light. Many Watts of green light can be generated and with very good spectral and spatial quality by the process of second harmonic generation (SHG) [1]. Sum frequency generation (SFG) is another process of generating green light by mixing the output from two laser sources. SFG between two similar DBR tapered diode lasers was recently demonstrated to generate up to 3.9 W of nearly diffraction limited light at 531 nm [2]. In this work, we demonstrate the concept of combining two tapered diode lasers at different wavelengths (978 nm and 1063 nm), and thereby generate 509 nm green light by SFG.

The experimental setup

The SFG process is obtained by frequency adding of

- 6.17 W from a 978 nm tapered diode laser
- 8.06 W from a 1063 nm tapered diode laser
- Focused inside a periodically poled MgO doped lithium niobate crystal
- Using a 60 mm lens (proved to be optimum for the SFG process)

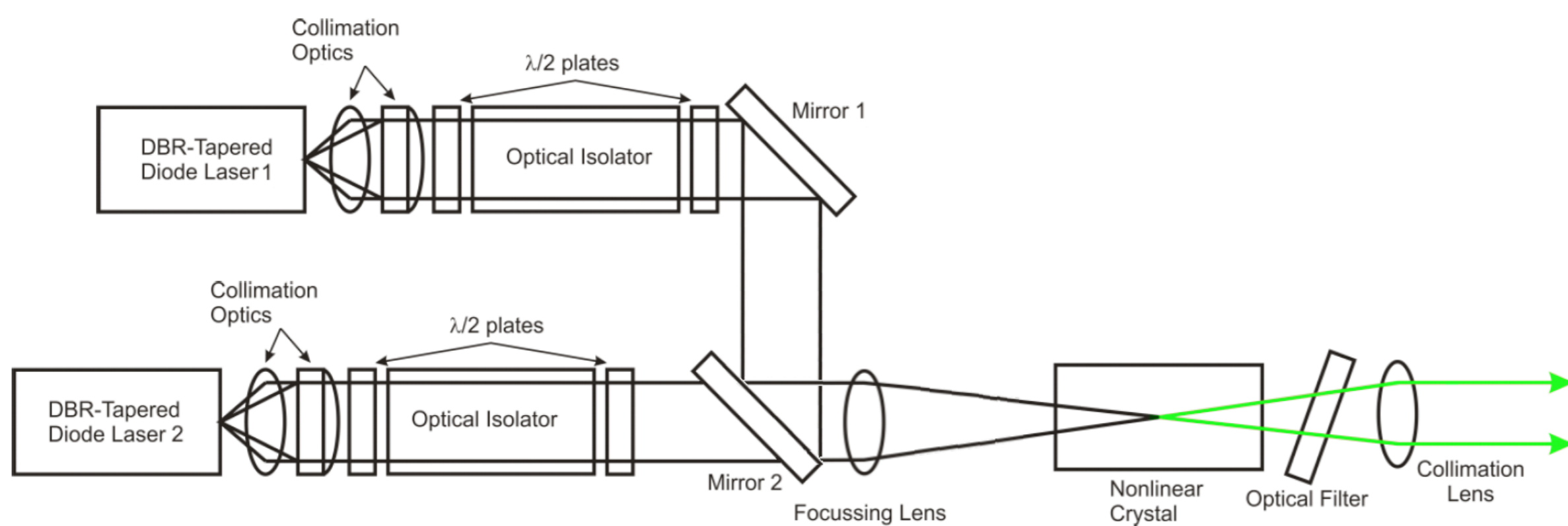

Figure 1: Setup for spectral beam combining of DBR-tapered diode lasers with subsequent sum-frequency generation.

Results

In this study we demonstrate:

- 1.7 W narrow linewidth green 509 nm light source
- Nearly diffraction limited light with $M^2=1.1$ in the fast and the slow axis
- Optical to optical conversion efficiency of 12.1 %
- Non-linear conversion efficiency of 4.3 %/W

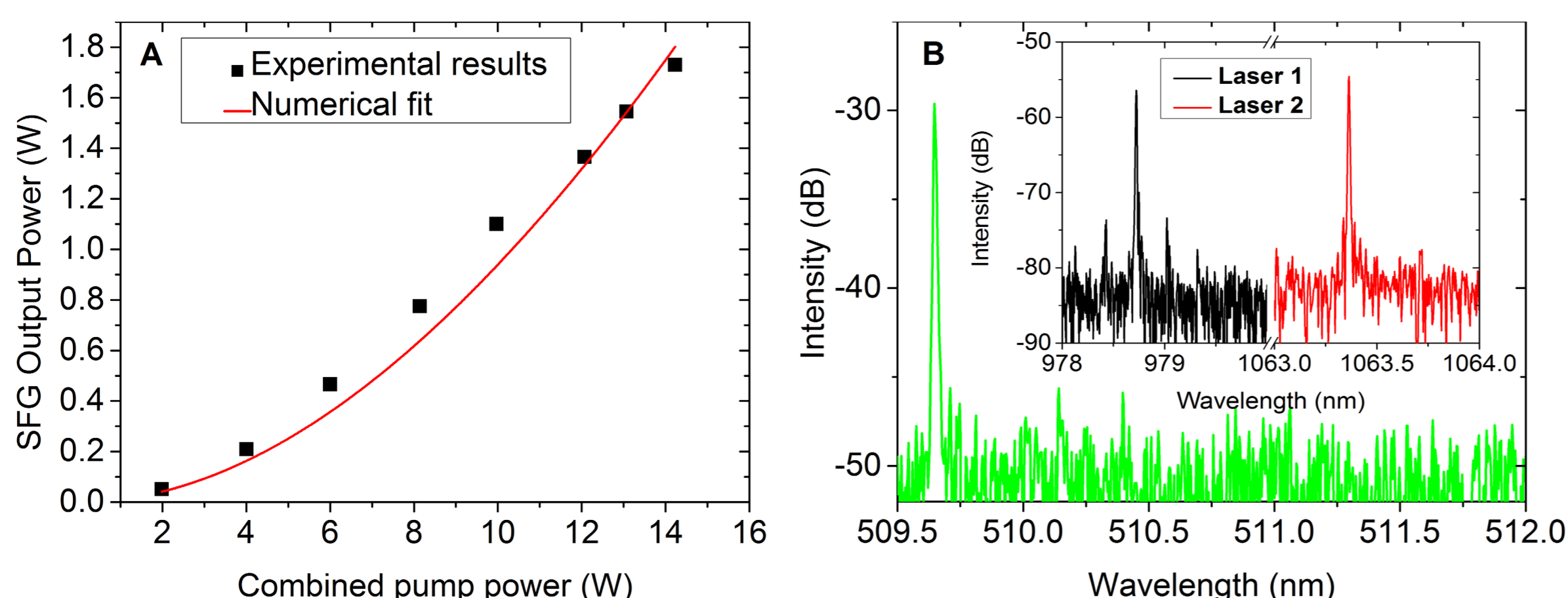

Figure 2: (A) : SFG output power vs. combined input power. The red curve is a numerical fit of the non-linear process, resulting in a nonlinear conversion efficiency of 4.3 %/W. (B) SFG Optical spectra of the SFG beam and the two individual beams.

Summary

Concept for generation of laser light based on SFG between tapered diode lasers with different wavelengths:

- Efficient generation of diffraction limited light
- Desired wavelength with narrow linewidth
- Relatively high emission power

Such light sources could be introduced in different optical systems where either high power at a specific wavelength is needed, or in systems where the reduction of cost and footprint would be advantageous.

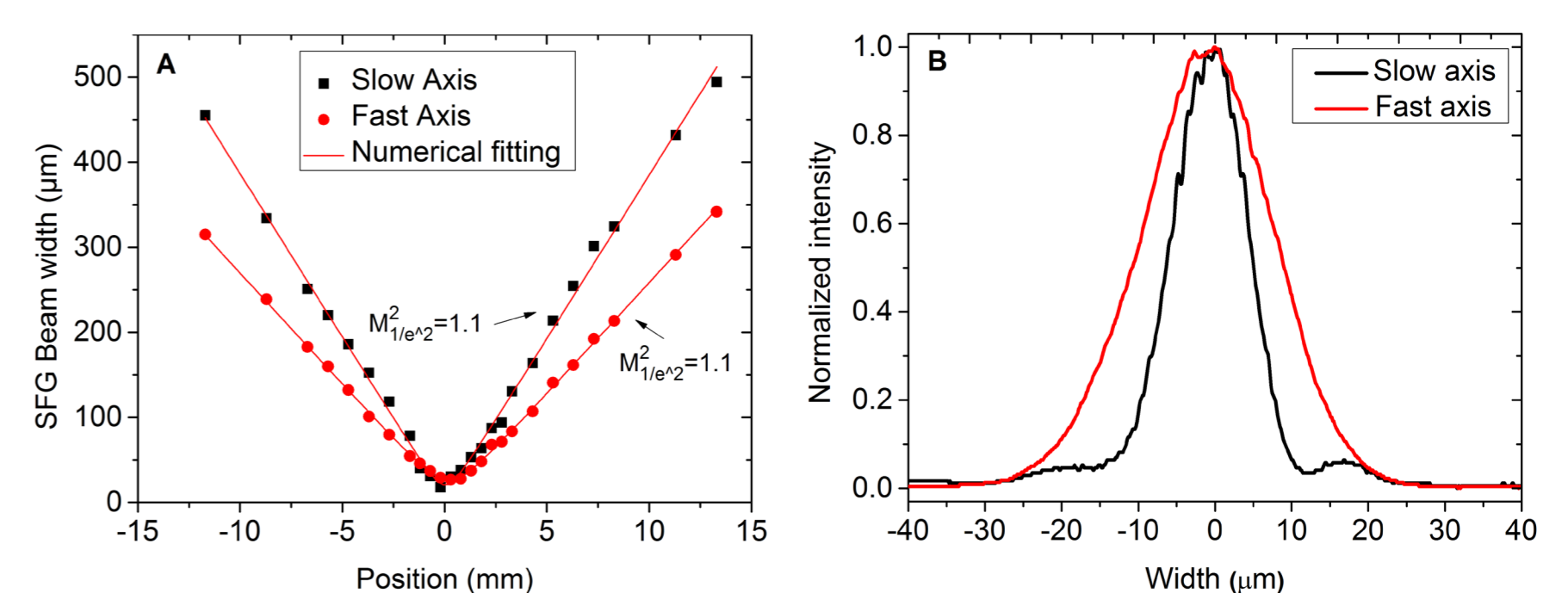

Figure 3: (A) M^2 measurements ($1/e^2$) of the SFG beam. The squares shows measurements of the slow axis, the circles shows the fast axis and the red curves represents the numerical fittings of the beam profiles. (B) Focused beam profiles of the slow- and the fast axis for the SFG.

Pumping Ti:Sapphire Laser

As a possible application, the 509 nm green light was used to pump a Ti:Sapphire laser

- Maximum Output Power of 226 mW (CW)
- Maximum Output Power of 185 mW (Mode-Locked)
- Spectral Width of about 54 nm (FWHM)

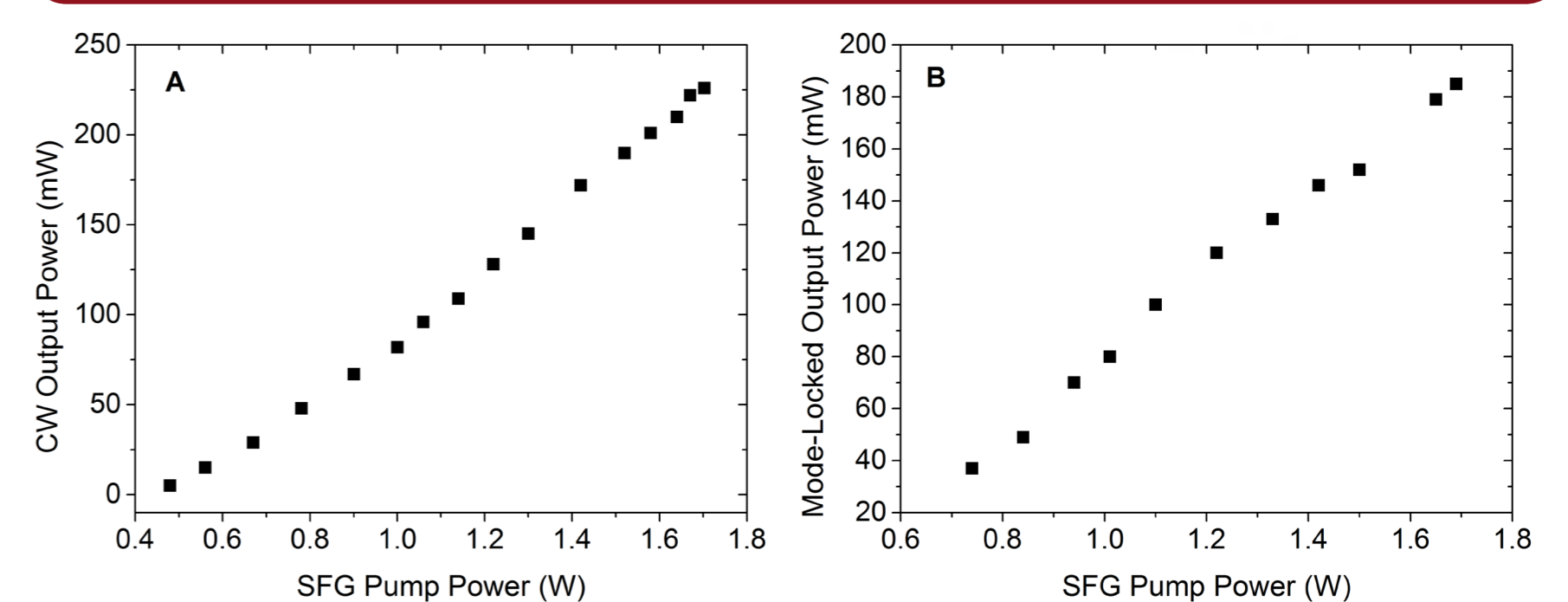

Figure 4: Ti:sapphire characteristics of (A) CW emission and (B) mode-locked emission, pumped by the 509 nm SFG laser.

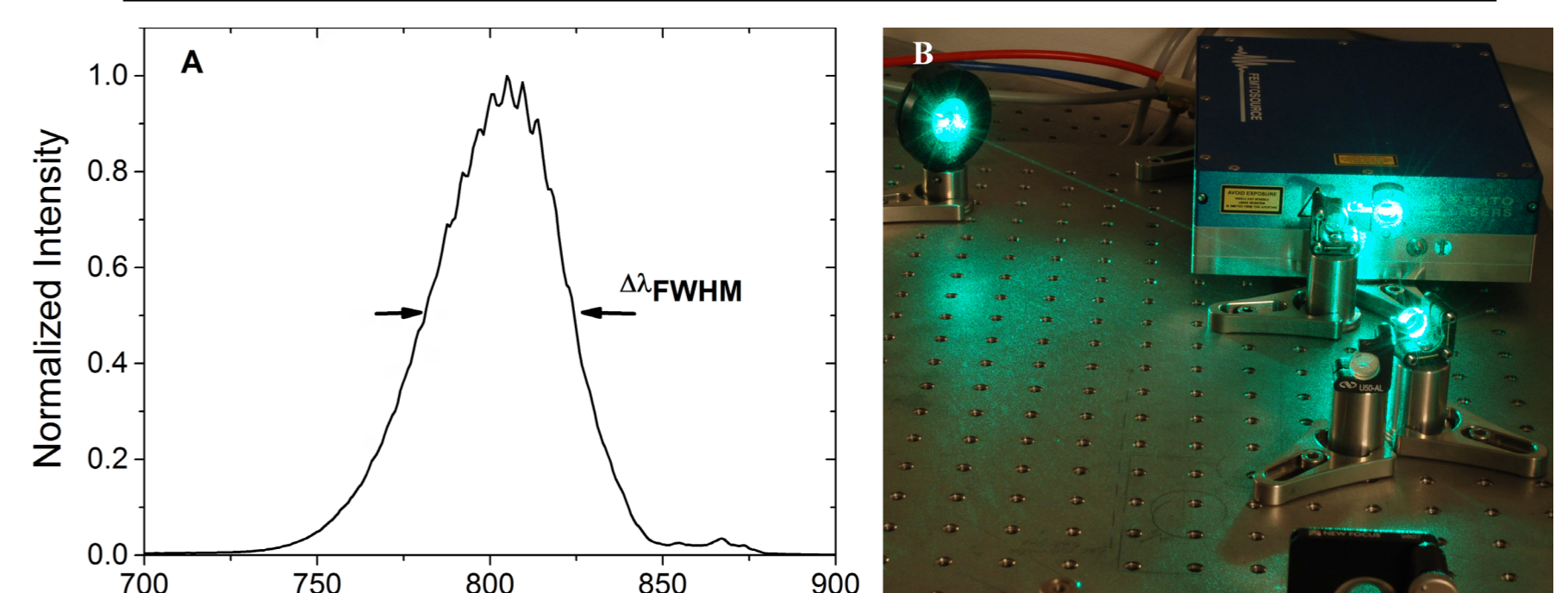

Figure 5: (A) Optical spectrum of the mode-locked Ti:sapphire laser, directly pumped by the 509 nm laser. (B) Image of the pumped Ti:Sapphire Laser.

Acknowledgment

This research was supported by the European project FAMOS (FP7 ICT 317744). We gratefully acknowledge Femtolasers Produktions GmbH for providing the Ti:Sapphire laser.

References

- [1] L. McDonagh and R. Wallenstein, "Low-noise 62 W CW intracavity-doubled TEM₀₀ Nd:YVO₄ green laser pumped at 888 nm.," Opt. Lett. 32, 802–804 (2007).
- [2] A. Müller, O. B. Jensen, K.-H. Hasler, B. Sumpf, G. Erbert, P. E. Andersen, and P. M. Petersen, "Efficient concept for generation of diffraction-limited green light by sum-frequency generation of spectrally combined tapered diode lasers.," Opt. Lett. 37, 3753–3755 (2012).

10th International Young Scientist conference
"Developments in Optics and Communications"
Riga, April 9 - 12, 2014

