

Technical University of Denmark



4 × 160-Gbit/s multi-channel regeneration in a single fiber

Wang, Ju; Ji, Hua; Hu, Hao; Yu, Jinlong; Mulvad, Hans Christian Hansen; Galili, Michael; Jeppesen, Palle; Oxenløwe, Leif Katsuo

Published in:
Optics Express

Link to article, DOI:
[10.1364/OE.22.011456](https://doi.org/10.1364/OE.22.011456)

Publication date:
2014

Document Version
Publisher's PDF, also known as Version of record

[Link back to DTU Orbit](#)

Citation (APA):
Wang, J., Ji, H., Hu, H., Yu, J., Mulvad, H. C. H., Galili, M., ... Oxenløwe, L. K. (2014). 4 × 160-Gbit/s multi-channel regeneration in a single fiber. *Optics Express*, 22(10), 11456-11464. DOI: 10.1364/OE.22.011456

DTU Library

Technical Information Center of Denmark

General rights

Copyright and moral rights for the publications made accessible in the public portal are retained by the authors and/or other copyright owners and it is a condition of accessing publications that users recognise and abide by the legal requirements associated with these rights.

- Users may download and print one copy of any publication from the public portal for the purpose of private study or research.
- You may not further distribute the material or use it for any profit-making activity or commercial gain
- You may freely distribute the URL identifying the publication in the public portal

If you believe that this document breaches copyright please contact us providing details, and we will remove access to the work immediately and investigate your claim.

4 × 160-Gbit/s multi-channel regeneration in a single fiber

Ju Wang,¹ Hua Ji,² Hao Hu,² Jinlong Yu,^{1,*} Hans Christian Hansen Mulvad,² Michael Galili,² Palle Jeppesen,² and Leif Katsuo Oxenløwe²

¹ School of Electrical and Information Engineering, Tianjin University, Tianjin 300072, China

² DTU Fotonik, Department of Photonics Engineering, Technical University of Denmark, Ørstedts Plads, Building 343, 2800 Kgs. Lyngby, Denmark

*yujinlong@tju.edu.cn

Abstract: Simultaneous regeneration of four high-speed (160 Gbit/s) wavelength-division multiplexed (WDM) and polarization-division multiplexed (PDM) signals in a single highly nonlinear fiber (HNLF) is demonstrated. The regeneration operation is based on four-wave mixing in HNLF, where the degraded data signals are applied as the pump. As a result, the noise on both ‘0’ and ‘1’ levels can be suppressed simultaneously in our scheme. The stimulated Brillouin scattering (SBS) from the continuous wave (CW) is suppressed by cross-phase modulation (XPM) from the data pump, relieving the requirement of external phase modulation of the CW light. Mitigation of the inter-channel nonlinearities is achieved mainly through an inter-channel 0.5 bit slot time delay. Bidirectional propagation is also applied to relieve the inter-channel four-wave mixing. The multi-channel regeneration performance is validated by bit-error rate (BER) measurements. The receiver powers at the BER of 10⁻⁹ are improved by 1.9 dB, 1.8 dB, 1.6 dB and 1.5 dB for the four data channels, respectively.

©2014 Optical Society of America

OCIS codes: (070.4340) Nonlinear optical signal processing; (060.2330) Fiber optics communications; (190.4975) Parametric processes.

References and links

1. M. Matsumoto, “Fiber-Based All-Optical Signal Regeneration,” *IEEE J. Sel. Top. Quant.* **18**(2), 738–752 (2012).
2. A. Bogoni, X. Wu, S. R. Nuccio, and A. E. Willner, “640 Gb/s All-Optical Regenerator Based on a Periodically Poled Lithium Niobate Waveguide,” *J. Lightwave Technol.* **30**(12), 1829–1834 (2012).
3. L. Provost, F. Parmigiani, P. Petropoulos, and D. J. Richardson, “Investigation of simultaneous 2R regeneration of two 40-Gb/s channels in a single optical fiber,” *IEEE Photon. Technol. Lett.* **20**(4), 270–272 (2008).
4. L. Provost, F. Parmigiani, P. Petropoulos, D. J. Richardson, K. Mukasa, M. Takahashi, J. Hiroishi, and M. Tadakuma, “Investigation of Four-wavelength Regenerator Using Polarization- and Direction-Multiplexing,” *IEEE Photon. Technol. Lett.* **20**(20), 1676–1678 (2008).
5. J. Wang, J. Yu, T. Meng, W. Miao, B. Sun, W. Wang, and E. Yang, “Simultaneous 3R Regeneration of 4×40-Gbit/s WDM Signals in a Single Fiber,” *IEEE Photon. J.* **4**(5), 1816–1822 (2012).
6. F. Parmigiani, P. Vorreau, L. Provost, K. Mukasa, M. Takahashi, M. Tadakuma, P. Petropoulos, D. J. Richardson, W. Freude, and J. Leuthold, “2R Regeneration of Two 130 Gbit/s Channels Within a Single Fiber,” *Proc. Opt. Fiber Commun. Conf., JThA56* (2009).
7. C. Yu, T. Luo, B. Zhang, Z. Pan, M. Adler, Y. Wang, J. E. McGeehan, and A. E. Willner, “Wavelength-shift-free 3R Regenerator for 40-Gbit/s RZ System by Optical Parametric Amplification in Fiber,” *IEEE Photon. Technol. Lett.* **18**(24), 2569–2571 (2006).
8. C. Peucheret, M. Lorenzen, J. Seoane, D. Noordegraaf, C. V. Nielsen, L. Grüner-Nielsen, and K. Rottwitt, “Amplitude regeneration of RZ-DPSK Signals in Single-Pump Fiber-Optic Parametric Amplifiers,” *IEEE Photon. Technol. Lett.* **21**(13), 872–874 (2009).
9. J. Luo, J. Yu, B. Han, B. Wu, J. Wang, W. Wang, H. Hu, and E. Yang, “Simultaneous Dual-Channel Retiming and Reshaping Using Two Independent Phase Clocks in Fiber-Optic Parametric Amplification,” *IEEE Photon. Tech. Lett.* **22**(11), 760–762 (2010).
10. A. Bogris and D. Syvridis, “Regenerative Properties of a Pump-Modulated Four-Wave Mixing Scheme in Dispersion-Shifted Fibers,” *J. Lightwave Technol.* **21**(9), 1892–1902 (2003).

11. J. Wang, H. Ji, H. C. H. Mulvad, M. Galili, E. Palushani, P. Jeppesen, J. L. Yu, and L. K. Oxenløwe, "All-optical 2R regeneration of a 160-Gbit/s RZ-OOK serial data signal using a FOPA," IEEE Photonics Conference, p. MM4 (2012).
12. J. Wang, J. Yu, J. Luo, W. Wang, B. Han, B. Wu, and E. Yang, "40-Gb/s 2-channel all-Optical 3R regeneration using data-pump fiber parametric amplification based on HNLF," IEEE Asia Communications and Photonics Conference, p. 86–87 (2010).
13. K. Inoue, "Suppression of level fluctuation without extinction ratio degradation based on output saturation in higher order optical parametric interaction in fiber," IEEE Photon. Technol. Lett. **13**(4), 338–340 (2001).
14. G. P. Agrawal, Nonlinear Fiber Optics, Fourth Edition, Academic Press, 2007.
15. M. Takahashi, M. Tadakuma, R. Sugizaki, and T. Yagi, "SBS Suppression Techniques In Highly Nonlinear Fibers," IEEE Photon. Summer Top. Meetings., p. 149-150 (2010).
16. H. Hu, E. Palushani, M. Galili, H. C. H. Mulvad, A. Clausen, L. K. Oxenløwe, and P. Jeppesen, "640 Gbit/s and 1.28 Tbit/s polarisation insensitive all optical wavelength conversion," Opt. Express **18**(10), 9961–9966 (2010).

1. Introduction

Optical signals propagating in fiber-optic transmission systems are impaired by various sources, which limit their transmission distance [1]. All-optical regeneration is a valuable functionality that can potentially extend the distance of digital-signal transmission beyond this limitation in a larger network. All-optical regenerators have the capability of signal processing at ultra-high speeds and potentially lower power consumption. The highest data rate achieved for single channel all-optical regeneration is 640-Gbit/s in a periodically poled lithium niobate waveguide (PPLN) [2]. As most transmission today is based on multi-channels systems, it would be beneficial if such a high speed optical regenerator could deal with multi-channel signals, but this has so far proven difficult, because of detrimental inter-channel cross-talk due to effects such as XPM, cross gain modulation (XGM) and four-wave mixing (FWM). A number of studies have been reported on all-optical signal regeneration using HNLF, among which few focused on high-speed (e.g. 160-Gb/s) multi-channel regeneration [3–6]. Bidirectional multiplexing can be used for two-channel regeneration where pattern-dependent nonlinear inter-channel interaction is avoided by the rapid walk-through between the signals traveling in opposite directions. If orthogonal polarizations are used, four-channel regeneration can be achieved, where inter-channel nonlinearities are avoided in time by using data signals with very short pulse duration (e.g. duty cycle is much less 50%) [4]. In [5], all-optical 3R regeneration for 4×40 -Gbit/s WDM channels in a dispersion-shifted fiber (DSF) was demonstrated. This scheme can process data signals with practical pulse duration (e.g. 33% or 50% duty cycle) by utilizing an inter-channel 0.5 bit slot time delay.

In this paper, we demonstrate simultaneous all-optical regeneration for four 160-Gbit/s WDM and PDM channels, using FWM in a HNLF. The regenerator is based on the FWM with a data modulated pump, which increases the SBS threshold. The amplitude noise on both '0' and '1' levels of the data signal can be suppressed simultaneously. Bidirectional propagation in the fiber and polarization multiplexing are used to relieve the inter-channel interference among the four channels. A 0.5 bit slot time delay between the two co-propagating signals introduced by an optical delay line (ODL) can mitigate the inter-channel interference [5]. The regeneration performances are confirmed by BER measurements.

2. Concept

2.1 Data-pump FWM

FWM in HNLF have the potential of operating at ultra-high bit rates. Over the years, many works have been reported on the development of all-optical regenerators based on FWM [7–13]. Some involve the use of CW pumps. When using CW light as the pump, the amplitude noise on the '1' level can be suppressed due to gain saturation of the data signal [7, 8]. But the noise on the '0' level cannot be suppressed and might even be amplified. If the data signal is used as the pump, as shown in Fig. 1, the same parametric process can be used to amplify an idler signal. When the data power is low ('0' levels), the amplifier gain of the idler wave is exponentially dependent on the data power [14]. The amplitude noise on '0' levels can be

suppressed at the idler wavelength. For the data at high power ('1' levels), the phase matching will deteriorate due to a nonlinear phase shift [14] which will result in the gain suppression of the idler wave. In this case, the amplitude noise on '1' levels can be suppressed. Thus in the Fig. 1 scheme, the amplitude noise on both '0' and '1' levels of the data signal can be suppressed simultaneously. At the same time, in a regenerator with modulated pump, the obtained four wave mixing product can exhibit a significantly enhanced extinction ratio [10]. In paper [11], a regenerator of a 160-Gbit/s return-to-zero on-off keying (RZ-OOK) signal is demonstrated using a highly nonlinear fiber with the data signal as pump. In the experiment of paper [11], BER bathtub curves of the back-to-back (B2B), degraded and regenerated data signals are measured at the same received average power of -31.5 dBm, as shown in Fig. 2. It can be seen that the degradation results in a much narrower error-free opening in the bathtub curve than the B2B case, i.e. corresponding to a closing of the eye diagram. After regeneration, the regenerated data signal has a broader error-free opening in the bathtub curve than the degraded data signal. The '0' level shows a little change, and the '1' level is very clearly improved. The BER bathtub curves confirm the clear opening of the regenerated eye diagrams on both '0' levels and '1' levels.

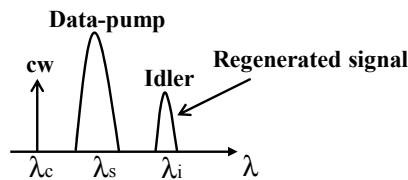

Fig. 1. FWM principle using data pump.

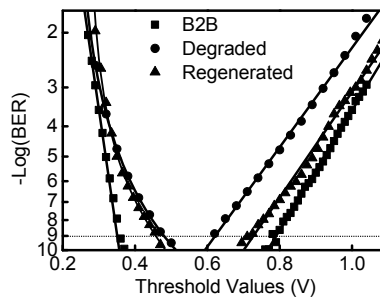

Fig. 2. BER bathtub curves for back-to-back, degraded and regenerated 160-Gbit/s RZ-OOK signals.

In this paper, the wavelengths allocation of the 4×160 -Gbit/s WDM-PDM data signals and two CW lights is shown in Fig. 3(a). Data1, data2, data3 and data4 comprise the four WDM and PDM channels. Data1 and data2 are at the wavelength of 1560 nm and with orthogonal polarizations. Data3 and data4 are at the wavelength of 1547 nm and also with orthogonal polarizations. The wavelengths of the two CW beams are 1574 nm and 1533 nm, respectively. The degraded data signals are applied as the pump in the FWM processes. The idlers are the regenerated signals. The power transfer curves of the two FWM in the HNLF used for the regenerator (parameters are described in the experimental setup) are measured. The powers of the two CW lights are fixed at 17.2 dBm (1574 nm) and 21.2 dBm (1533 nm), which are optimized for the saturation of the FWM with different pump wavelengths. As shown in Fig. 3(b), the exponential idler response of the FWM at lower pump level allows for reducing the 0-level noise. For higher data pump power ('1' levels), the idler power saturates because of the nonlinear phase mismatch [14]. Thus, the noise on both '0' and '1' levels can be suppressed simultaneously in our experiment.

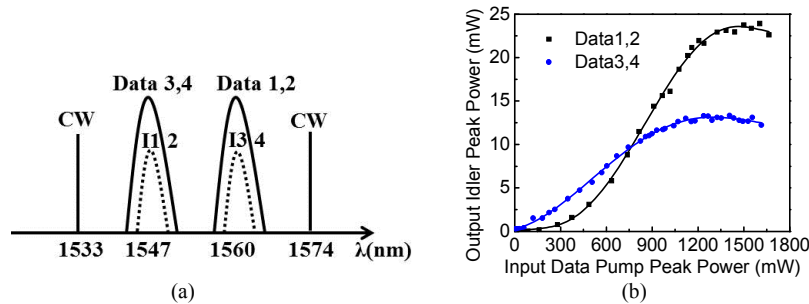

Fig. 3. (a) wavelengths of the 4×160 -Gbit/s data signals and two cw lights (b) FWM transfer curves for the two wavelengths.

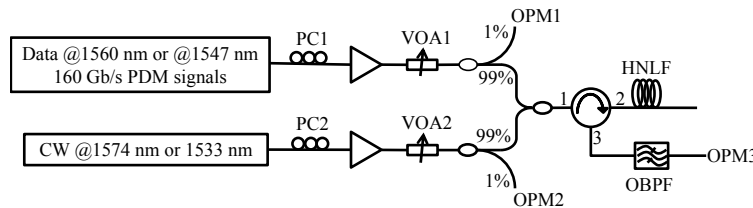

Fig. 4. Experimental setup of SBS measurement in data-pump FWM. PC: polarization controller; VOA: variable optical attenuator; OPM: optical power meter; OBPF: optical bandpass filter; HNLF: highly non-linear fiber.

2.2 SBS suppression

In many cases, all-optical regenerators based on FWM in HNLF have CW light as pump. However, SBS is a severe limitation as the power of the CW pumps increase. Several techniques have been proposed to minimize SBS [7–9, 15], most of which are based on external phase modulation of the pump to broaden its spectrum using several sinusoidal tones or pseudorandom bit sequence (PRBS) data. In our scheme, the degraded data signals are used as the pump, the power of the CW light does not need to be so high. In addition, the spectrum of the CW light is broadened by cross-phase modulation from the data signal, which increases the SBS threshold.

The experimental setup of SBS measurement in the data-pump FWM is shown in Fig. 4. 160-Gbit/s PDM signals at 1560 nm (data1 and data2) are amplified by a high-power EDFA. A variable optical attenuator (VOA1) is used to control the data power. Then data1 and data2 goes into an optical coupler with a splitting ratio of 99%:1%. The 99%-port is connected with a 3-dB optical coupler. The 1%-port is used to monitor the injected data power. The CW light at 1574 nm is amplified by another high-power EDFA. VOA2 is used to control the injected CW power. Then the CW light goes into another optical coupler with a splitting ratio of 99%:1%, the 99%-port of which is connected with the other port of the 3-dB optical coupler. The output of the 3-dB coupler is connected with port1 of a circulator. The data signal and the CW light are launched into the HNLF which is used in the regenerator (parameters are described in the experimental setup) through port2 of the circulator. Two polarization controllers are adjusted to make the nonlinear processes (e.g. FWM and XPM) most effective. The reflected SBS light is monitored at port3.

Figure 5(a) shows the reflected SBS power as a function of CW power with different input data (data1 and data2) powers (20.4 dBm, 24.1 dBm and without data input respectively). The data powers and the CW powers are all measured at the input of the HNLF. When the input data power is 24.1 dBm and the CW power is 24.6 dBm, the reflected SBS power is suppressed by 24.5 dB, compared to the case of without data pump. The SBS suppression condition for data3- and data4- pump and CW light at 1533 nm is shown in Fig. 5(b). The

reflected SBS power as a function of CW power with different input data (data3 and data4) powers (22.6 dBm, 24.5 dBm and without data input respectively). When the input data power is 24.5 dBm and the CW power is 21 dBm, the reflected SBS power is suppressed by 19.5 dB compared to the case of without data pump.

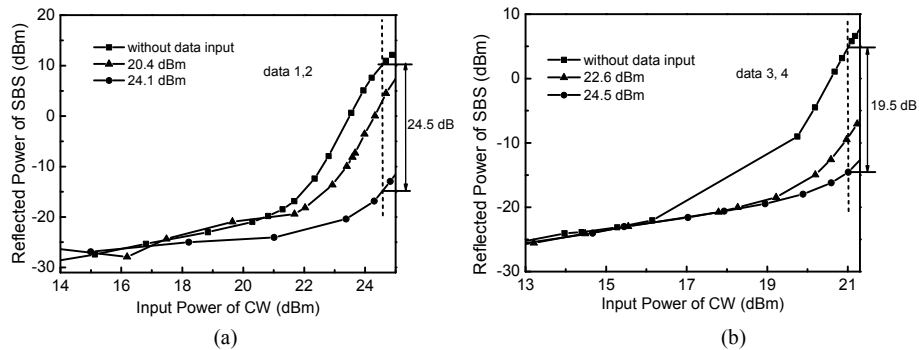

Fig. 5. Reflected SBS power versus input CW power (a) data 1, 2 (b) data 3, 4.

2.3 Mitigation of inter-channel interference

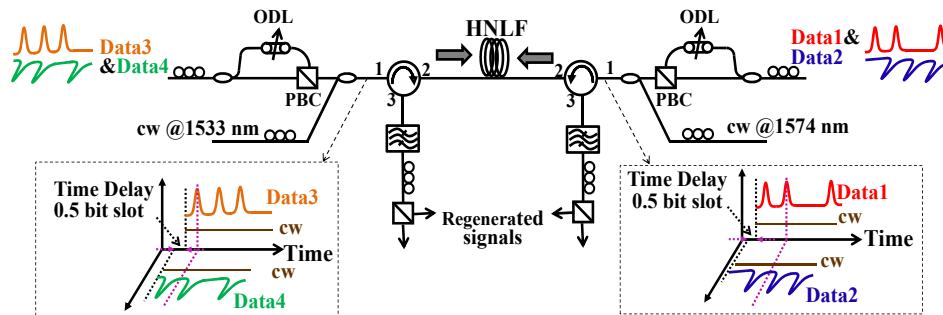

Fig. 6. Principle of regenerator operation for 4×160 -Gbit/s WDM-PDM signals, which is based on FWM in a single fiber.

Most of the demonstrated multi-channel regeneration schemes are based on fiber nonlinearities. However, inter-channel interferences such as XPM, XGM and FWM usually limit their performance. Mitigation of inter-channel interference is another issue, which should be solved in our experiment.

Figure 6 shows the principle of regenerator operation for 4×160 -Gbit/s WDM-PDM signals. By using bidirectional propagation of four channels at different wavelengths, simultaneous regeneration of four WDM-PDM channels can be achieved. Data1 and data2 are multiplexed in orthogonal polarization at the same wavelength of 1560 nm. Data3 and data4 are polarization orthogonally multiplexed and at the wavelength of 1547 nm. Data1, data2 and CW light at 1574 nm are launched into the HNLF forward. Data3, data4 and CW light at 1533 nm are launched in the opposite direction. The CW beam at 1574 nm is adjusted to 45° with respect to data1 and data2, and the same goes for the CW beam at 1533 nm, data3 and data4. Bidirectional multiplexing is used for regeneration where pattern-dependent nonlinear inter-channel interaction (e.g. FWM, XPM and XGM) is avoided by the rapid walk-through between the signals traveling in opposite directions [4].

For the two PDM data signals propagating in the same direction, the inter-channel interference cannot be completely suppressed due to the limited polarization extinction ratio of the device. Inter-channel XPM, and XGM via CW pump still exist between the two data channels with orthogonal polarization in the same direction. To further mitigate the inter-

channel XPM and XGM, a 0.5 bit slot time delay between the two data channels in the same direction is introduced, as shown in Fig. 6. A polarization maintaining optical coupler (PM coupler) is used to separate the two orthogonal polarized data signals into two parts. The two outputs of the coupler are connected to the two inputs of a polarization beam combiner (PBC). An ODL is inserted into one connection of the PM coupler and the PBC, in order to introduce the 0.5 bit slot time delay. At the output of the PBC, when one data signal is at the pulse peak, the other data signal will be at the pulse bottom. In this way, when they are launched into the HNLF to produce FWM, the XPM and XGM between orthogonally polarized channel-pairs will be suppressed sufficiently [5].

3. Experimental setup

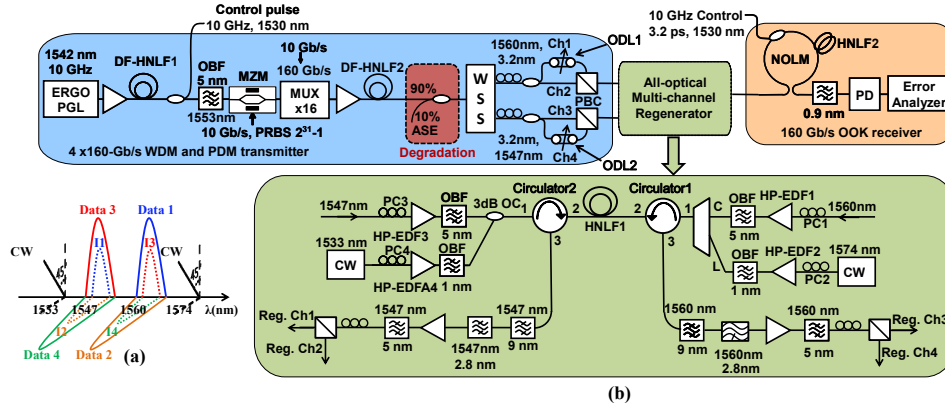

Fig. 7. (a) Wavelength position and polarization relationship of the four channels and CW signals; (b) Experimental setup of the regenerator of 4×160 -Gbit/s WDM and PDM channels

Figure 7(a) shows the polarization and wavelength allocation of the four WDM-PDM data signals and two CW signals. Data1, data2, data3 and data4 comprise the four WDM and PDM channels. Data1 and data2 are at the same wavelength and with orthogonal polarizations and the same for data3 and data4. The regenerator includes a polarization controlling stage in order to make the two CW beams linearly polarized. The CW beam at 1574 nm is adjusted to 45° with respect to data1 and data2, and the same goes for the CW beam at 1533 nm, data3 and data4. In our scheme, the degraded data signals act as pumps in the FWM processes and the reshaped data signal replicas are generated on the idler wavelengths. The transfer curves are measured and shown in Fig. 3(b), indicating that the amplitude noise on both ‘0’ and ‘1’ levels can be suppressed simultaneously. Note that, in Fig. 3(a), the regenerated data1 and data2 (corresponding to I1 and I2) are at the same wavelengths as the incoming data3 and data4 in this scheme (the same for I3 and I4 with data1 and data2). In this way, the output wavelengths of the regenerator occupy the same bandwidth as the input data wavelengths.

The experimental setup of the regeneration of the four 160-Gbit/s WDM and PDM signals is shown in Fig. 7(b). It includes the generation of the four 160-Gbit/s WDM and PDM data signals, a fiber based multichannel regenerator, an OTDM demultiplexer and a BER tester. A degradation unit is introduced in the transmitter.

An erbium glass oscillating pulse-generating laser (ERGO-PGL) generates 10-GHz pulses at 1542 nm with a full-width at half-maximum of 1.5 ps. The 10-GHz pulses are spectrally broadened in a 200-m dispersion-flattened HNLF (DF-HNLF1, dispersion slope $S = 0.017$ ps/nm²/km at 1550 nm, zero-dispersion wavelength at 1553.3 nm, nonlinear coefficient $\gamma = 10.5$ W⁻¹km⁻¹) by self-phase modulation (SPM) [16]. The output spectrum of DF-HNLF1 is split and filtered at two wavelengths to obtain data and control signals. A 5-nm optical band-pass filter (OBF) centered at 1553 nm is used to obtain 10-GHz pulses for the data signal, and

a 1-nm OBF at 1530 nm is used to obtain the 10-GHz control pulses for a nonlinear optical loop mirror (NOLM) based OTDM demultiplexer. The 10-GHz pulses at 1553 nm are modulated by a 10 Gbit/s PRBS ($2^{31}-1$) signal in a Mach-Zehnder modulator (MZM). The modulated 10-Gbit/s RZ-OOK signal is multiplexed in time to 160-Gbit/s using a passive fiber-delay multiplexer ($\text{MUX} \times 16$). The 160-Gbit/s OTDM signal is amplified and then injected into a 400-m dispersion-flattened HNLFF (DF-HNLFF2, dispersion $D = -0.45$ ps/nm/km, slope $S = 0.006$ ps/nm²/km at 1550 nm, and $\gamma = 10.5$ W⁻¹km⁻¹) to generate a supercontinuum. The supercontinuum is launched into a degradation subunit. The supercontinuum (average power is 14 dBm) and broadband amplified spontaneous emission (ASE) noise (average power is 13 dBm) are combined using a 10-dB coupler. After optical bandpass filtering in a wavelength selective switch (WSS, 3-dB bandwidth is 3.2 nm), two degraded WDM signals at 1560 nm and 1547 nm are obtained. Note that only in-band ASE noise is added after the WSS. The data signal at 1560 nm goes into a 3-dB PM coupler. The two outputs of the coupler are connected to the two inputs of a PBC. At the output of the PBC, two PDM degraded data signals (data1 and data2) are obtained. Data3 and data4 are generated in the same way.

In the all-optical multichannel regenerator, data1 and data2 are amplified by a high-power EDFA (HP-EDFA1). The CW beam at 1574 nm is amplified by another high-power EDFA (HP-EDFA2). Data1, data2 and the 1574 nm CW beam are injected into HNLFF1 (200m, zero-dispersion wavelength at 1554 nm, dispersion slope $S = 0.053$ ps/nm²/km and non-linear coefficient $\gamma = 10.5$ W⁻¹km⁻¹) through a WDM (C band and L band combiner). ODL1 between the PM coupler and PBC is used to introduce a 0.5 bit slot delay between data1 and data2 before launching the data into HNLFF1. Two polarization controllers (PC1 and PC2) are used to adjust the polarization of the CW beam at 45° with respect to data1 and data2. The same relative polarizations are set for data3, data4 and the CW beam at 1533 nm, which are combined by a 3-dB coupler. The output powers of HP-EDFA1, HP-EDFA2, HP-EDFA3 and HP-EDFA4 are optimized. Two circulators (Circulator1 and Circulator2) are located at the two sides of HNLFF1 to separate the in- and out-going signals. At port3 of Circulator2, the regenerated data1 and data2 (the FWM idler products) together with the original degraded data signals and the CW beam are launched into a filtering subsystem, which consists of a 9-nm OBF, a WSS, an EDFA and a 5-nm OBF. The WSS is programmed with an OBF of 3-dB bandwidth 2.8-nm. This filtering subsystem is used to separate the regenerated data signal at 1547 nm from the original data signal and the CW beam. Finally, a polarization beam splitter (PBS) is utilized to polarization-demultiplex the regenerated data1 and data2. In the same way the regenerated data3 and data4 can be obtained.

The regenerated four 160-Gbit/s signals are detected by a 160-Gbit/s receiver based on a NOLM. The NOLM is used to demultiplex the 160-Gbit/s regenerated data signal down to the 10-Gbit/s signal tributaries. The NOLM operation is based on XPM in a 50-m HNLFF2 (zero-dispersion wavelength at 1545 nm, $S = 0.015$ ps/nm²/km at 1550 nm, and $\gamma = 10.5$ W⁻¹km⁻¹). The demultiplexed 10-Gbit/s signal is detected by a 10-Gbit/s optically pre-amplified receiver with a photodetector (PD). The performance of the received signal is evaluated by a 10-Gbit/s error analyzer.

4. Results

When all the four channels on, the spectra at the input and output of HNLFF1 for data1 and data2, and the spectrum of the regenerated data signal after filtering and amplification are shown in Fig. 8(a). The corresponding spectra for data3 and data4 are shown in Fig. 8(b). The conversion efficiencies of the two FWM idlers (at 1547 nm and 1560 nm) are measured to be -13 dB and -17 dB respectively. The data (data1 and data2) power and CW beam (at 1574 nm) power are 24.1 dBm and 24.6 dBm at the input of HNLFF1. The injected power of data3 and data4 is 24.5 dBm and that of CW beam at 1533 nm is 21 dBm.

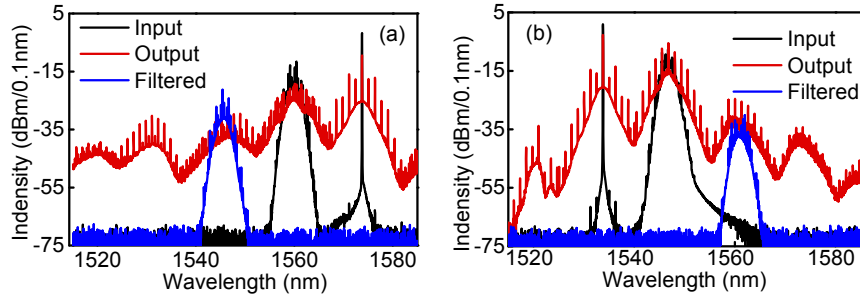

Fig. 8. Spectra at input and output of HNLF1 and the regenerated data signal after filtering and amplification for (a) data1 and data2, (b) that for data3 and data4.

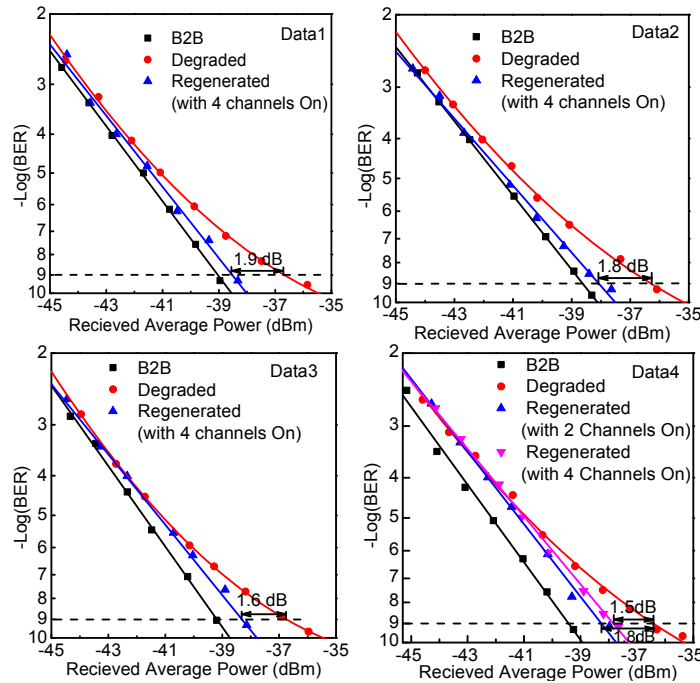

Fig. 9. 10-Gbit/s BER performance after demultiplexing for data1, data2, data3 and data4.

As shown in Figs. 8(a)-8(b), the spectrum of CW beam at 1574 nm and 1533 nm has been broadened obviously by XPM from data signals. Under these power conditions, the reflected SBS power as a function of CW power with different input data powers in Figs. 5(a)-5(b). For data1 and data2, when the input data power is 24.1 dBm, the reflected SBS power (the CW power is 24.6 dBm) is suppressed by 24.5 dB compared to the case of without data pump. For data3 and data4, when the input data power is 24.5 dBm, the reflected SBS power (the CW power is 21 dBm) is suppressed by 19.5 dB, relieving the requirement of external phase modulation of the CW light. BER measurements as a function of the receiver power for the B2B, degraded and regenerated cases for data1, data2, data3 and data4 are shown in Fig. 9. B2B here means the optimized 160-Gbit/s WDM and PDM data signal, i.e. without degradation added. BER curves are plotted for a 10-Gbit/s signal demultiplexed from the 160-Gbit/s RZ-OOK signal. The degradation unit introduces additional ASE noise to degrade the optical signal to noise ratio (OSNR) of the WDM-PDM signals. The degradation causes a beginning error floor at the BER of $\sim 10^{-9}$ for each of the data channels. Compared to the B2B case, data1, data2, data3 and data4 have 2.3 dB, 2.3 dB, 2.5 dB, and 3 dB power penalties at

the BER of 10^{-9} respectively. After regeneration the receiver powers at 10^{-9} BER are improved by 1.9 dB, 1.8 dB, 1.6 dB and 1.5 dB, respectively. The error floors are notably suppressed and the receiver sensitivities are all improved for all four data channels. The BER performance of the regenerated data4 with the all 4 channels on shows 0.3 dB power penalty compared to that with only 2 co-propagating channels on. This is mainly due to the effect of the Rayleigh back scattering as the regenerated data signals are at the identical wavelength with the original data signal (data1 and data2) coming from the opposite side. When the data power of data1 and 2 is 24.1 dBm, the Rayleigh backscattering power is measured to -12.8 dBm. As the simultaneous regeneration is performed, the injected power of data3 and data4 is 24.5 dBm and the power of the regenerated idlers is measured to 7.5 dBm. Thus the power difference between the regenerated idlers and the Rayleigh backscattering of data1 and data2 is 20.3 dB, which means the Rayleigh backscattering power is less than 1% of the regenerated idlers, indicating that the cross-talk for counter-propagation in the HNLF is minor.

5. Conclusion

We have demonstrated simultaneous all-optical regeneration for 4×160 -Gbit/s WDM and PDM channels based on FWM in a single HNLF. Direction and polarization multiplexing are used here and an inter-channel 0.5 bit slot time delay is introduced to further suppress interaction between the two co-propagating data signals. The SBS from the CW beam is suppressed by cross-phase modulation from the data pump, relieving the requirement of external phase modulation of the CW light. The FWM based regenerator using the degraded data signal as pump can suppress amplitude noise on both '0' and '1' levels simultaneously, which is validated by BER bathtub curves. The regenerator performance is confirmed by BER measurements, showing sensitivity improvements of 1.5-1.9 dB for the four WDM-PDM data channels.