

Features of Electronic Emission from Surface of Dielectric Thin-film Materials with Ion-beam Etching

A. Kurochka¹, A. Sergienko¹, S. Kurochka¹, V. Kolybelkin²

¹ National University of Science and Technology «MISIS» (MISIS), 4, Leninskiy Pr., Moscow, Russia

² Research and production corporation "Istok", 2A, Vokzalnaya Str., Fryazino, Moscow Region, Russia

(Received 19 May 2014; published online 15 July 2014)

This work presents a series of experimental studies aimed at validating the main theoretical aspects of the ion-electron emission in conditions of ion-beam etching and lookup the possibility of practical realization of the method of operative control processes ion-beam etching different dielectric thin film materials of electronic technics.

In the real article the estimation of influence of the pointed superficial potential is conducted in dielectric tape on the integral signal of secondary electrons at an ionic etch.

The electric field strength in dielectric film under the influence of the induced potential creates prerequisites for the emergence of "Malterovskay" emission, defined by properties actually dielectric and properties of the substrate.

Keywords: Ion-electronic emission, Ion-beam etching, Secondary electron current, Electric field strength, Electron affinity, Surface electron states, Surface potential.

PACS number: 79.90. + b

1. INTRODUCTION

The use of signal of ion-electronic emission for control of process of an ion-beam etches takes on the special significance at forming of heterostructures including dielectric thin-films [1-3].

Research of ion-electronic emission from the surface of massive dielectrics the great number of works is sanctified to [4-5]. It is set that value of coefficient of ion-electronic emission γ for them in 10-100 times higher, and thresholding of energies for kinetic emission on an order less than, what for metals. A substantial contribution to electronic emission gives excitation of electrons from the valence zone of dielectric, that is the kinetic breaking of electrons out of dielectric carries by volume character.

Published results on ion-electronic emission in the process of an ion-beam etch, including reactive, dielectric thin-films very limit. In-process [6] the comparative analysis of relative change of coefficient of ion-electronic emission is conducted for metallic, oxide and nitride of thin-films at a magnetron etch by the ions of Ar⁺.

2. EXPERIMENTAL SECTION

In the real article the estimation of influence of the pointed superficial potential is conducted in dielectric tape on the integral signal of secondary electrons at an ionic etch. Conformities to law of change of current of secondary electrons I_{se} are investigated at a reactive ion-beam etch of heterostructures, containing tapes of nitrides and oxides.

Experimental results and discussion of research methodology for the receipt of results on electronic emission the series of experiments were conducted on specially formed thin-films multi-layered heterocompositions:

- dielectric / semiconductor (Si₃N₄ / Si);
- dielectric / metal / semiconductor (Ta₂O₅ / Al / Si);
- metal / dielectric / semiconductor (Al / TiO₂ / Si).

The prepared standards of multi-layered structures were subjected reactive ion-beam etch in mixture of gases of Ar (80 %) + CF₄ (20 %) with control of integral signal of current of secondary electrons in the process of etch.

Measuring of current of secondary electrons I_{se} in the process of ionic etch with the use of the electric chart presented on a Fig. 1.

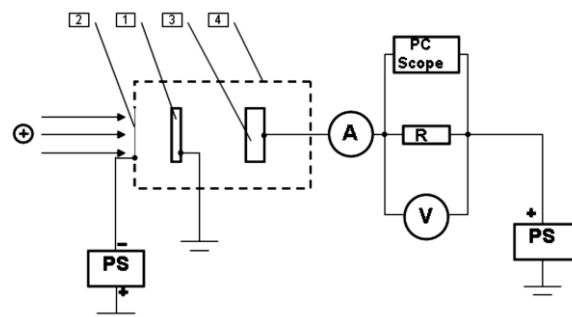

Fig. 1 – Electrical scheme of the experiment: 1 – sample, 2 – metal grid, 3 – electron receiver, 4 – metal container with a diaphragm

For prevention of hit of primary particles, charged secondary particles (negative and positive ions) and tertiary electrons the receiver of electrons is situated after the investigated standard.

The results of measuring of current of secondary electrons in the process of ionic etch are presented on a Fig. 2.

The level of integral signal of current of secondary electrons from the surface of the investigated structures is similar to the analogical signal for metallic and semiconductor materials.

Following the substantive provisions of physics of surface, it is possible to suppose that emission properties of dielectric thin-films depend on electric field, form in a dielectrics superficial potential, pointed ionic

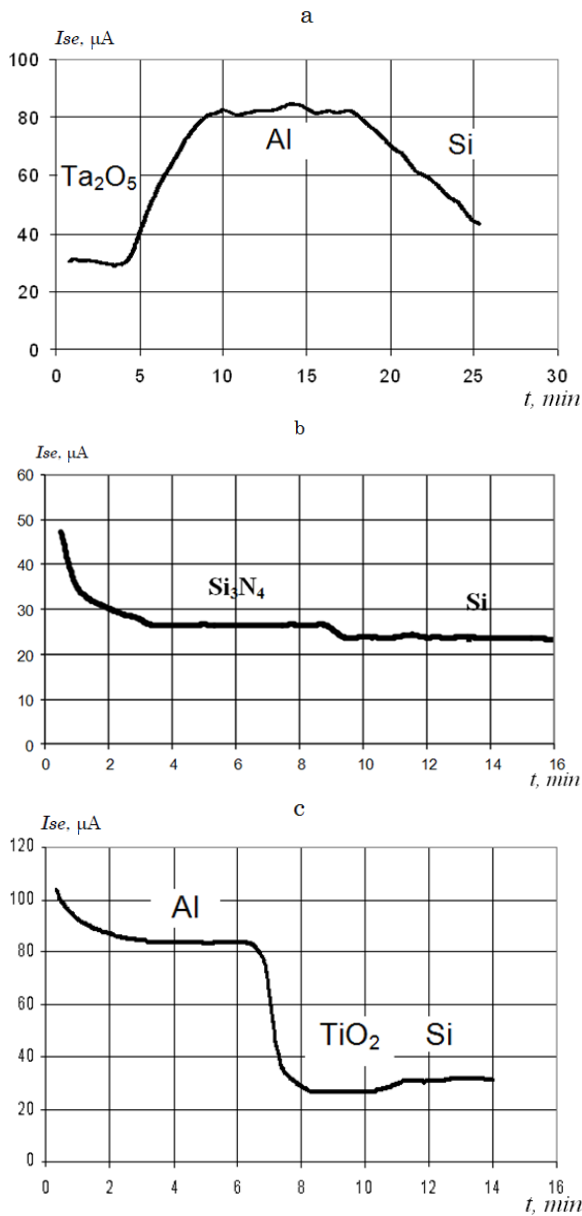

a) Ta₂O₅/ Al / Si, b) Si₃N₄/ Si, c) Al / TiO₂/ Si

Fig. 2 – Dependence of current of secondary electrons I_{se} on time of etch t structures in mixture of gases of Ar (80 %) + CF₄(20 %)

bunch in the process of ionic etch. The surface potential, pointed by an ionic bunch in the prospected dielectric tapes at the saturation of current of the secondary electrons caught by a receiver, was determined on methodology by expounded in [7], bit tension was set at the level of 1 kV, current of ions – 50 μA, the saturation of current of secondary electrons was fixed at potential on a receiver to 300 V.

The results of measuring are presented on a fig. 3. It ensues from the got results, that at the small values of the potential given on the receiver of U_{rec} , in technological space of working chamber there is the electric field insufficient for catching of part of secondary electrons. With the increase of U_{rec} the amount of electrons able to attain the surface of receiver increases and the saturation of current of secondary electrons comes under reaching some boundary value $U_{rec} = U_{boun}$.

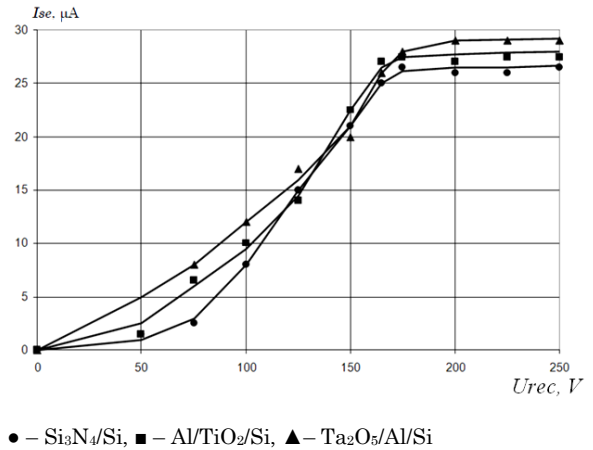

● – Si₃N₄/Si, ■ – Al/TiO₂/Si, ▲ – Ta₂O₅/Al/Si

Fig. 3 – Dependence of current of secondary electrons I_{se} on potential on the receiver of U_{rec} .

Potential at that there is a saturation of current of secondary electrons of U_{reg} for dielectric tapes of Si₃N₄ – 180 V, Ta₂O₅ – 210 V, TiO₂ – 190 V (± 5 V).

Superficial potential created by an ionic bunch, on the surface of dielectric tape determined on a formula [7]:

$$\varphi_n = \frac{r_i}{\sqrt{\pi L}} U_{boun}$$

where r_i – is a radius of ionic bunch on the surface of tape, L – it is distance between substrate and receiver.

Superficial potential φ_n made for: Si₃N₄ – 20,8 V, Ta₂O₅ – 24,3 V, TiO₂ – 21,9 V.

Electric field strength in the volume of dielectric tape made: Si₃N₄ – $21 \cdot 10^{-7}$ V/m, Ta₂O₅ – $24,3 \cdot 10^{-7}$ V/m, TiO₂ – $21,9 \cdot 10^{-7}$ V/m.

In a structure metal – dielectric at presence of positive potential on dielectric tape electrons of inject from a metal in a dielectric. For clarification of mechanism of Malterovskay emission it is necessary to analyse physical processes what be going on in dielectric tape under influence of internal electric field.

Three areas of origin of potential are possible in a structure: border of structure metallic tape - dielectric tape, material of dielectric, pores in tape of dielectric.

Substantial role in the mechanism of emission of Malter taken to porosity of tape of dielectric. Free runs of electrons in the pores comparable with the linear sizes of pores along the field. At motion in pores electrons can accumulate energy, sufficient for the shock ionizing, increasing the amount of electrons in the zone of conductivity of dielectric.

It should be noted that level of current of secondary electrons from the surface of the dielectric tapes besieged on wafers from different materials, differ on a size, id est determined by emission properties of wafer.

3. CONCLUSION

Experimental researches of thin-films structures: dielectric – a semiconductor, dielectric – metal – semiconductor, metal – dielectric – semiconductor, allowed to estimate influence of the pointed superficial positive potential on the size of current of secondary electrons. The theoretical estimation of the pointed potential the size of that made for tape of Si₃N₄ is conducted – 20,8 V, for tape of

Ta₂O₅ – 24,3 V, for tape of TiO₂ – 21,3 V.

Electric field strength, arising up in dielectric tape under influence of the pointed potential, creates pre-

conditions for the origin of the Malterovskay emission determined by properties actually dielectrics and by properties of wafer.

REFERENCES

1. R. Teshev, G. Kuznetsov, *Izv. Universities. The materials of electronic technics* No 2, (2002) [in Russian].
2. G. Kuznetsov, S. Simakin, N. Kislov, A. Sergienko, *Izv. Universities. The materials of electronic technics* No4, (2004) [in Russian].
3. G. Kuznetsov, A. Kurochka, A. Sergienko, S. Kurochka, *The materials of electronic technics* No3 (M: MISiS: 2011).
4. A. Aksenov, D. Noskov, (Tomsk: Tomsk State University of Control Systems and Radio Engineering: 2007).
5. S. Cernusca, M. Fursatz, H. Winter, *Europhys. Lett.* **70** No6, [768](#) (2005).
6. D. Depla, X. Y. Li, S. Mahieu, R. Degryse, *J. Phys. D: Appl. Phys.* **41**, [202003](#) (2008).
7. G.G. Bondarenko, A.I. Bazhin, A.P. Korzhavyi, V.I. Kristya, R.D. Aitov, *Tech Phys.* **43**, [1121](#) (1998).