

Research Article

Design of a Turbulence Generator of Medium Consistency Pulp Pumps

Hong Li, Haifei Zhuang, and Weihao Geng

Research Center of Fluid Machinery Engineering and Technology of Jiangsu University, Zhenjiang, Jiangsu 212013, China

Correspondence should be addressed to Haifei Zhuang, zhf05110103@163.com

Received 30 April 2011; Revised 26 November 2011; Accepted 8 December 2011

Academic Editor: Arthur Lees

Copyright © 2012 Hong Li et al. This is an open access article distributed under the Creative Commons Attribution License, which permits unrestricted use, distribution, and reproduction in any medium, provided the original work is properly cited.

The turbulence generator is a key component of medium consistency centrifugal pulp pumps, with functions to fluidize the medium consistency pulp and to separate gas from the liquid. Structure sizes of the generator affect the hydraulic performance. The radius and the blade laying angle are two important structural sizes of a turbulence generator. Starting with the research on the flow inside and shearing characteristics of the MC pulp, a simple mathematical model at the flow section of the shearing chamber is built, and the formula and procedure to calculate the radius of the turbulence generator are established. The blade laying angle is referenced from the turbine agitator which has the similar shape with the turbulence generator, and the CFD simulation is applied to study the different flow fields with different blade laying angles. Then the recommended blade laying angle of the turbulence generator is formed to be between 60° and 75° .

1. Introduction

MC (Medium Consistency) pulp pumps are key equipment to transport pulp in modern paper mills. Paper pulp suspension contains three kinds of media, namely, fibers, water, and air, which results in a high flow complexity and particularity in the pump itself. The pulp cannot move when the pulp mass consistency is more than 6%. In order to transport the medium with the consistency over 6%, the MC pulp pumps must have the ability to fluidize the pulp. The turbulence generator is the key component of the MC centrifugal pulp pump, which fluidizes the MC pulp and separates the gas from the pulp suspension. The structure of MC pulp pumps is shown in Figure 1.

Some research had been done in China [1–4], including the simulation of fluidization of paper pulp suspension and the optimized designs of the turbulence generator. But the systemic design theories and methods are still not built. Starting with the research on the flow and shearing characteristics of the MC pulp, a simple mathematic model is built, and the formula for calculating the radius of the turbulence generator is established. The range of the blade laying angle is obtained by the recommended blade laying angle from the turbine agitator which has the same shape as

the turbulence generator, and the CFD simulation is applied to study the different flow fields with different blade laying angles.

2. Deducing the Critical Shear Velocity Gradient

The flow of MC pulp suspension is neither similar to usual water flow, nor to two-phase flow or liquid-particle flow. It is a kind of three-phase fluid, consisting of gas-liquid (water)-solid (fiber) flow. It has very complicated flow characteristics, changing with the species, consistency, and velocity of the paper pulp and the fiber shape.

High consistency of the fibers and gas/air in the MC pulp makes the fiber suspensions fail to move forward freely. By high-speed rotation, the turbulence generator introduces high shearing force to distribute fibrous reticulum and also avoid fibers to flocculate again. In this situation, pulp fiber suspensions show the flow characteristics as similar to water. Therefore it is defined as fluidization [4].

The minimum shear force which makes fibrous reticulum of the MC pulp suspension distributed is called the critical shear force. Based on experimental researches on

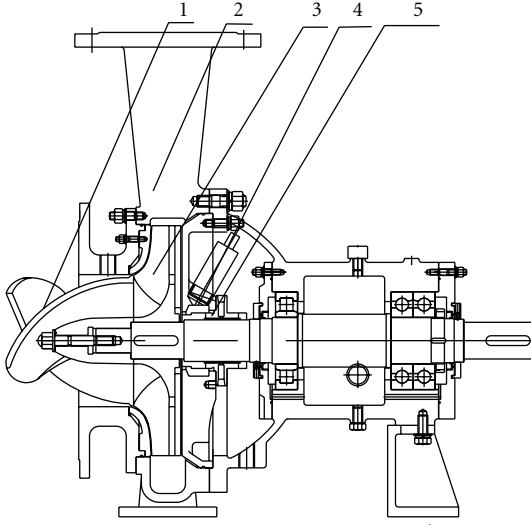

FIGURE 1: MC pulp pump. (1) Turbulence generator. (2) Casing. (3) Impeller. (4) Gas outlet. (5) Mechanical seal.

sulphated wood pulp by Hemstrom et al. [5], the critical shear force τ_d can be given as

$$\tau_d = KC^a, \quad (1)$$

where K and a are the coefficients related to the species of the paper pulp. For given species of the paper pulp, the critical shear force τ_d is only related to C , which is the mass consistency of the paper pulp suspension.

The apparent viscosity of the non-Newtonian fluid is defined as the ratio of the shear force to the shear velocity [6]. The apparent viscosity, μ_a (Pa·s), is given by

$$\tau_d = \mu_a \frac{du}{dr} = \mu_a S_w, \quad (2)$$

where τ_d is the shear force (Pa) and S_w is the shear velocity gradient (1/s). We can get the critical shear velocity gradient of the paper pulp by (1), but for the actual generator design, there is no direct relationship between the critical shear force and the geometric parameters. So we need to change the condition parameter of the fluidization from the critical shear force to the critical shear velocity gradient, by analyzing the relationship between the shear force, the shear velocity, and the shear velocity gradient.

Duffy et al. [7] obtained the apparent viscosity of straw wood pulp by experiments. The apparent viscosity, μ_a , is given by

$$\mu_a = 0.178C^{3.30}S_w^{-0.75}, \quad (3)$$

simultaneously by (2) and (3)

$$\begin{aligned} \tau_d &= \mu_a \frac{du}{dr} \\ &= 0.178C^{3.30}S_w^{-0.75} \cdot S_w \\ &= 0.178C^{3.30}S_w^{0.25}, \end{aligned} \quad (4)$$

TABLE 1: K , α , τ_d ($C = 15\%$) and S_{wd} of seven kinds of paper pulp.

Species of paper pulp	K	α	τ_d	S_{wd}
Bleaching poplar wood pulp	27.3	1.98	5818.66	341.4
Unbleached poplar wood pulp	18.9	2.04	4739.01	150.2
Spruce wood pulp	6.7	2.43	4830.33	162.1
Bleaching redpine sulphate wood pulp	5.74	2.52	5286.34	231.5
Unbleached redpine sulphate wood pulp	5.38	2.52	4949.17	216.9
Unbleached stone ground wood pulp	0.4	3.49	5088.84	199.7
Unbleached waste paper pulp	0.15	3.8	4073.4	113.5

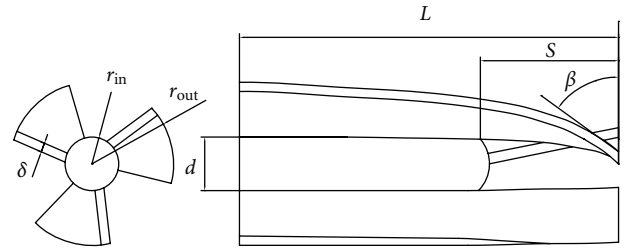

FIGURE 2: Turbulence generator. r_{out} is the blade outlet radius; r_{in} is the blade inlet radius; d is the hub diameter; δ is the blade thickness; β is the blade laying angle; S is the blade overhang length; L is the blade total length.

where S_{wd} is the shear velocity gradient for the fluidization of paper pulp.

Simultaneously by (1) and (4)

$$\begin{aligned} KC^a &= 0.178C^{3.30}S_{wd}^{0.25}, \\ S_{wd} &= (5.618KC^{a-3.30})^4. \end{aligned} \quad (5)$$

Gullichsen and Harkonen [8] and Kefu [9] obtained the values of K and α with shearing experiments on MC pulp. Based on the experimental data and the formulations above, K , α , τ_d ($C = 15\%$) and S_{wd} of seven common kinds of paper pulp are obtained, as shown in Table 1.

3. Parameters of the Turbulence Generator

The turbulence generator in this research consists of a hub and three blades. The blade working face is perpendicular to the surface of the hub. Outside surfaces and inside surfaces of blades are all cylindrical surfaces.

Main parameters of a turbulence generator are shown in Figure 2.

The blade outlet radius and the blade laying angle are the most important design parameters, which are the preconditions of other structure sizes, deciding the working range and efficiency of the MC pulp pumps.

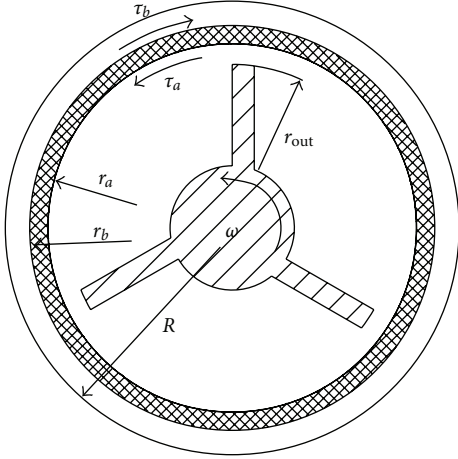

FIGURE 3: Flow at a section of the shearing chamber of the turbulence generator.

4. Blade Outlet Radius of Turbulence Generator

In this part, starting with the researches on the flow characteristics of the MC pulp suspension, a series of formulas are deduced to qualify the critical fluidization of MC pulp. The formulas for calculating the radius of the turbulence generator have then been established by simplifying the model of the flow field of the turbulence generator.

4.1. Calculating Blade Outlet Radius. As shown in Figure 3, supposing that the paper pulp suspension fills within the full flow passage, we analyze the force of laminar flow in the torus field at a section of the shearing chamber of the turbulence generator.

When the turbulence generator is rotating at a high speed, neglecting axial velocity, we can consider the paper pulp flow being laminar in the area from blade top of the turbulence generator to the inside wall of the shearing chamber. We note the shear force inside as τ_a and outside as τ_b , as shown in Figure 3. At the normal running condition, the momentum moment to axis in the grid flow field keeps constant. So the whole moment is zero. That is,

$$2\pi r_a \cdot \tau_a \cdot r_a = 2\pi r_b \cdot \tau_b \cdot r_b. \quad (6)$$

So,

$$\begin{aligned} \tau(r) \cdot r^2 &= M, \\ \tau(r) &= \frac{M}{r^2}, \end{aligned} \quad (7)$$

where M is a constant and $\tau(r)$ is the circumferential shear force at r radius position.

Based on formulas above, given the shearing chamber radius R and the shear force at the inside wall $\tau(R)$, we can obtain the momentum moment M :

$$M = \tau(R) \cdot R^2. \quad (8)$$

Combine (4), (7), and (8). S_w is given by,

$$\begin{aligned} 0.178C^{3.30}S_w(r)^{0.25} &= \frac{\tau(R) \cdot R^2}{r^2}, \\ S_w(r) &= \left(\frac{\tau(R) \cdot R^2}{0.178C^{3.30}r^2} \right)^4, \end{aligned} \quad (9)$$

where $S_w(r)$ is the radial velocity gradient when the radius is r .

In conditions of a laminar flow, the shear velocity gradient is inversely proportional to the distance to the rotating axis in the area from the blade top of the turbulence generator to the inside wall of the shearing chamber. So the shear force near the inside wall of the shearing chamber is the smallest. We can consider that the whole flow field becomes turbulent, if the shear velocity gradient near the inside wall reaches the critical value.

Define N as

$$N = \left(\frac{\tau(R) \cdot R^2}{0.178C^{3.30}} \right)^4. \quad (10)$$

where N is a constant which is decided by the species of the paper pulp and the shearing chamber radius R .

So (9) becomes,

$$S_w(r) = N \frac{1}{r^8}. \quad (11)$$

The velocity of pulp at the blade outlet of the turbulent generator is given by

$$\begin{aligned} v_{out} &= \int_{r_{out}}^R s_w(r) dr \\ &= N \left(\frac{1}{7r_{out}^7} - \frac{1}{7R^7} \right), \end{aligned} \quad (12)$$

$$v_{out} = 2\pi r_{out} \frac{n}{60}. \quad (13)$$

Combining (12) and (13) gives

$$r_{out} = \frac{30N}{7\pi n} \left(\frac{1}{r_{out}^7} - \frac{1}{R^7} \right). \quad (14)$$

From the formulas above, we can get the critical shear force τ_d from Table 1. Let $\tau(R)$ be equal to τ_d , and we get the minimal N from (10). Then r_{out} can be obtained from (14).

4.2. Design Example. The design parameters of an MC pulp pump are taken as follows: $Q = 60 \text{ m}^3/\text{h}$, $H = 50 \text{ m}$, $n = 1450 \text{ r/min}$, $C = 8\% - 15\%$, and the pump inlet diameter (shearing chamber diameter) $D = 150 \text{ mm}$.

Based on the parameters above and Table 1 when C is 15%, the critical shear force $\tau_d = \tau(R) = 5818.66 \text{ Pa}$, the shearing chamber radius $R = D/2 = 75 \text{ mm}$. So we get the following from (13):

$$N = \left(\frac{5818.66 \times 0.075^2}{0.178 \times 15^{3.30}} \right)^4 = 3.417 \times 10^{-7}. \quad (15)$$

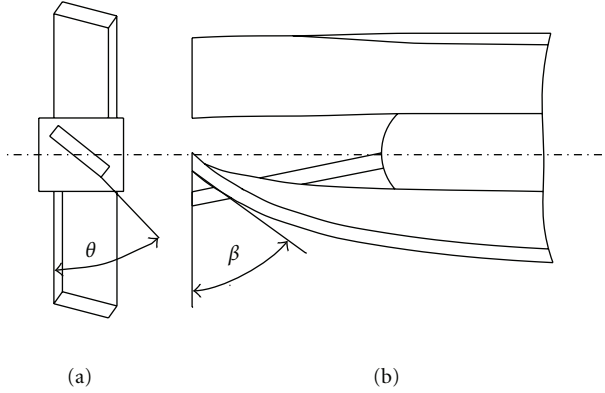

FIGURE 4: Pitched turbine type agitator (a) and turbulence generator (b).

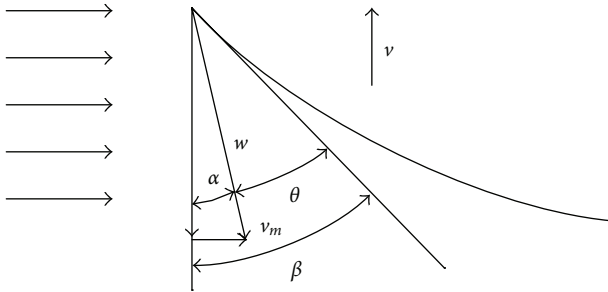

FIGURE 5: Velocities at the outlet streamline of the turbulence generator.

Finally, we obtain r_{out} from (14) that $r_{\text{out}} = 62.47$ mm. Let $r_{\text{out}} = 65$ mm after roundness.

By the experiment of the MC pulp pump with the turbulence generator of the sizes given above, the performance of the pump is checked and achieved in the paper published before [10]. This paper introduced the main structure of the test bed for the centrifugal pulp pump. The test result showed that the pump could run stably and efficiently under the 11% stock consistency in that test condition, with the efficiency to 40%. It testified the MC pump had a good performance, satisfying the pulp transporting needs.

5. Blade Laying Angles of Turbulence Generator

5.1. Setting Blade Laying Angle. The principle of the turbulence generator is similar to an agitator. The blade structure is similar to a pitched turbine agitator, as shown in Figure 4. The viscosity coefficient of the transporting medium in one agitator can reach 100 Pa.s, which matches up to that in the turbulence generator of the MC pulp pump. According to [11], the recommended blade laying angles are 45° , 60° , and 90° . The initial axial velocity inside the agitator is usually zero, but it is not null inside the pump. Compared to the recommended blade laying angle of the pitched turbine type agitator, the angle of the turbulence generator should be modified according to the actual flow.

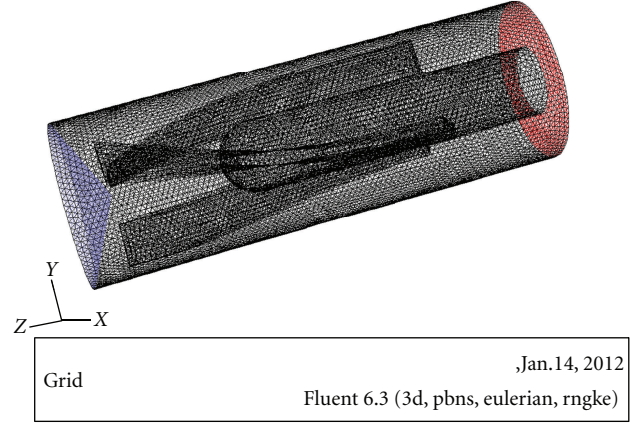

FIGURE 6: The grid of a turbulence generator.

Figure 5 shows the outlet streamline of the turbulence generator. α is the correction angle, which means the angle between relative velocity w direction and circumferential velocity direction at the blade outlet; θ is the recommended blade laying angle of the turbine agitator; β is the blade laying angle of outlet streamline.

We can obtain the following equations from Figure 5

$$\beta = \alpha + \theta, \quad (16)$$

$$\alpha = \arctan \frac{v_m}{v}, \quad (17)$$

$$v_m = \frac{Q}{\pi R^2}, \quad (18)$$

where Q is the volumetric flow (m^3/h); v_m is the axial velocity (m/s); w is the relative velocity (m/s); v is the linear velocity at the blade outlet (m/s); R is the shearing chamber radius of the turbulence generator (m).

In the application of the MC pulp pump, the rotating direction of the turbulence generator should be contrary to the pump impeller. The blade laying angle cannot exceed 90° , so α should be 0° when θ is already 90° .

The blade correction angle α is 10.8° after calculation by (17). According to (16), three blade laying angles β of the turbulence generator are 55.8° , 70.8° , and 90° , respectively.

5.2. CFD Simulation Model. CFD (Computational Fluid Dynamics) is used to calculate and analyze the flow field through solving basic equations, such as the momentum conservation equations, the mass conservation equations, and the energy conservation equations. The numerical simulations in this paper are performed using FLUENT 6.2.

The flow of the MC pulp suspension after fluidization is a turbulence flow, and the flow characteristics are similar to the gas-water two-phase flow, but the large amount of gas inside the pulp will influence the flow.

The research on the inner flow in the MC pulp pump focuses on the movement and distribution of gas in the paper pulp, interaction between gas and liquid, as well as the turbulence distribution in the flow field. So in the CFD simulation of the fiber suspension flow in the shearing

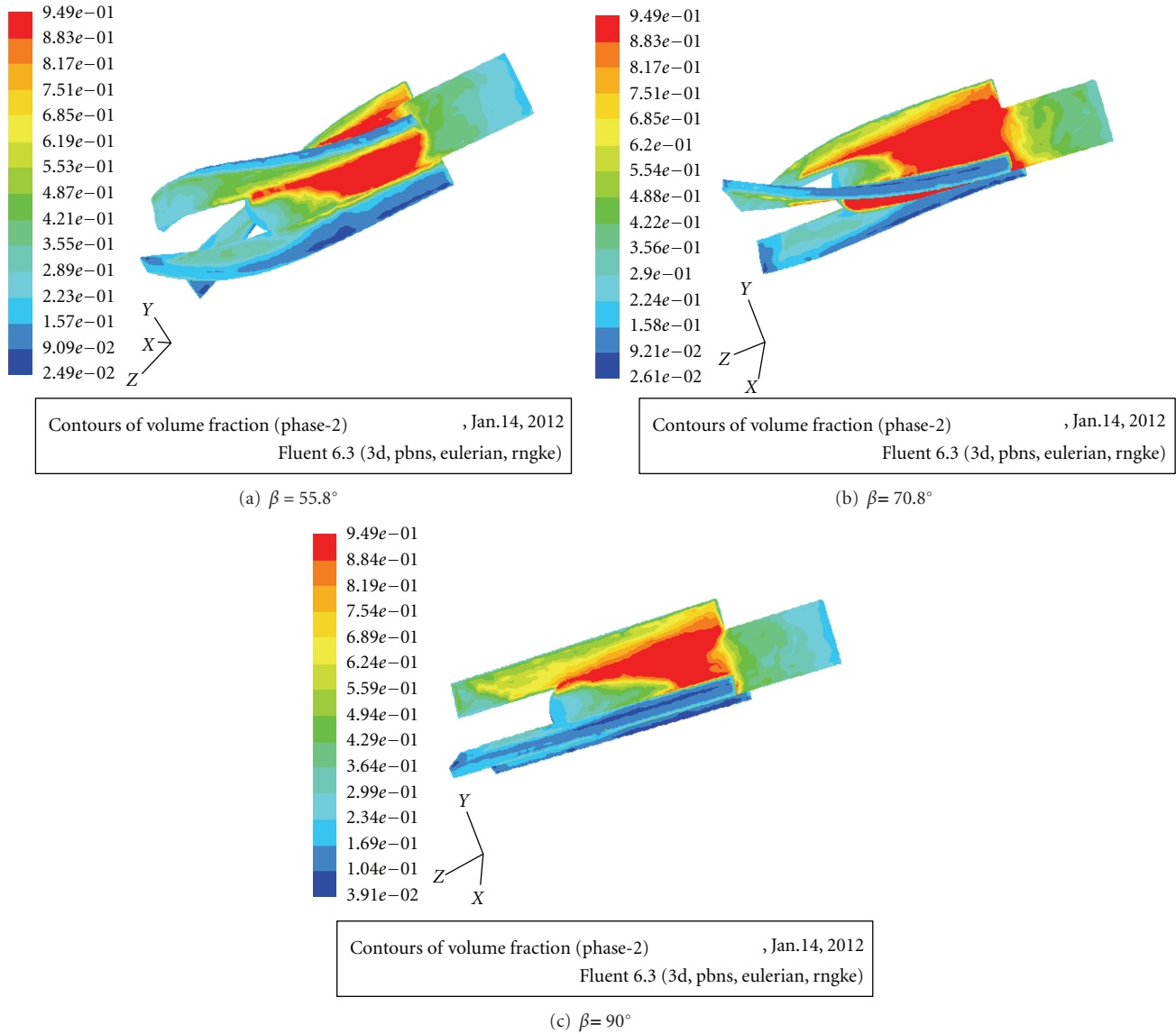

FIGURE 7: Gas distribution on the blade surfaces with different blade laying angles.

chamber, we apply Eulerian gas-liquid phase model and RNG $\kappa-\epsilon$ model, with RANS as momentum equations [12]. We use the MRF (Multiple Reference Frames) [13, 14] to build the frame, Phase Coupled SIMPLE to deal with the coupling of pressure and velocity, and the implicit steady-state segregating solution to solve the equations.

5.3. *Building 3D Models and Boundary Conditions.* We establish a 3D model and define the grid for the flow field of the turbulence generator when the blade laying angles β are 55.8° , 70.8° and 90° , respectively. We make the field a whole field to simplify the computation, as shown in Figure 6. Boundary conditions are determined as the real running conditions of the turbulence generator. The gas volume fraction is 20%.

5.4. *Analysis of the Simulation Results.* Simulation results are compared and analyzed, which are the effects on the gas-liquid separation, the turbulent kinetic energy, the torque produced by the turbulence generator, and the pressure changing from the outlet to the inlet of the turbulence generator.

(1) *Effects on Gas-Liquid Separation.* From Figure 7, we can observe that there is no big difference of effects on gas-liquid separation, with the gas volume fraction reaching almost 95% at the end of the turbulence generator. The blade impact angle from the medium will increase with the enlargement of the blade laying angle, which results in the low pressure field being strengthened and expanded on the suction face at the blade front part. So we can find that the bigger the blade

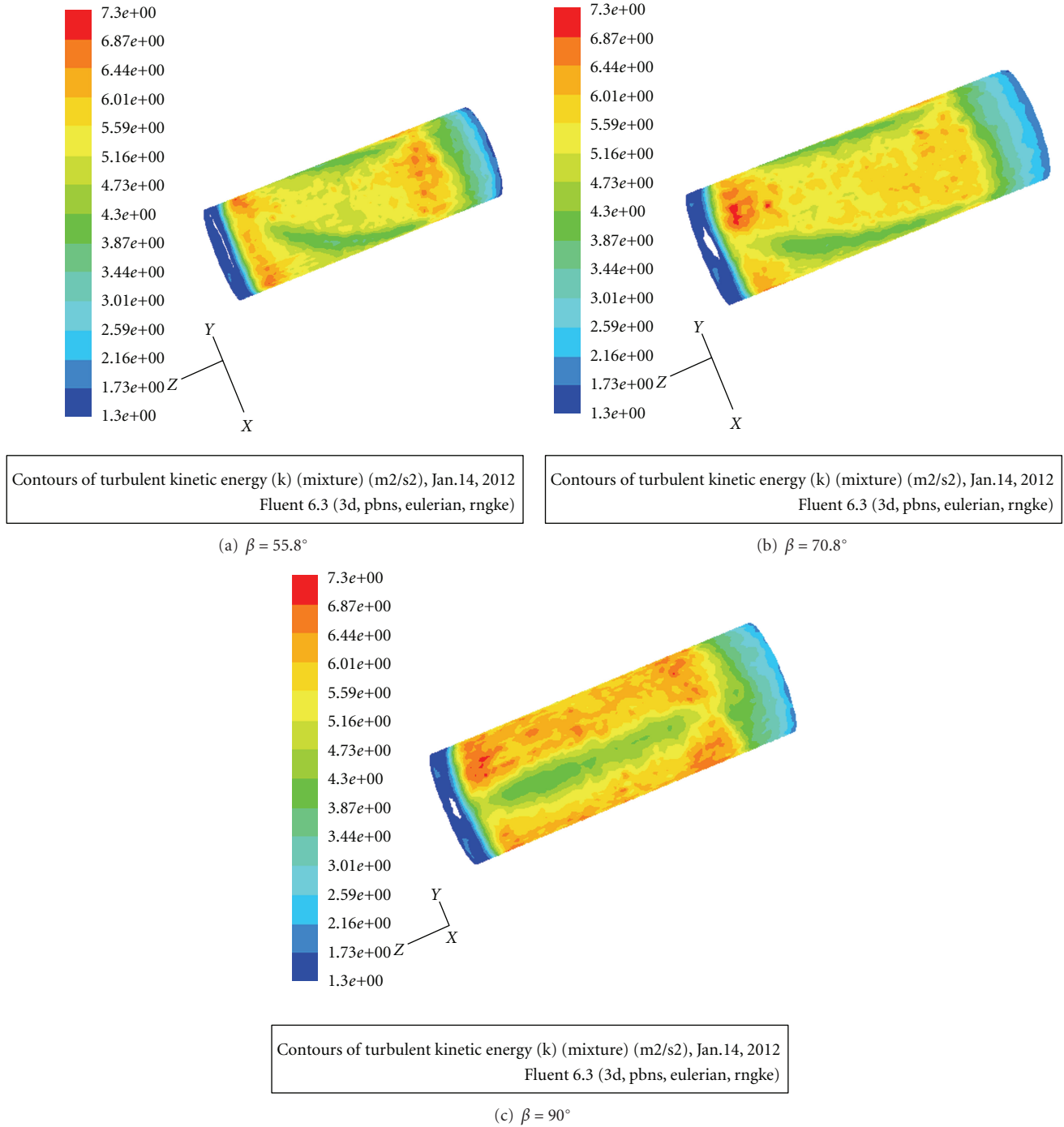

FIGURE 8: Turbulent kinetic energy distribution in shearing chamber with different blade laying angles.

laying angle is, the shorter the gas-liquid separation field is to the blade front part.

(2) *Turbulent Kinetic Energy Distribution.* According to Figure 8, the turbulent kinetic energy in the field between the blade outlets to the inside wall of the shearing chamber is lower than that around blades. And the distribution of the turbulent kinetic energy trends to be well distributed with the increase of the blade laying angle.

(3) *Targeted Values.* From Table 2, we can get that, with the increase of the blade laying angles β , the turbulence intensity will also increase, so did the torque value of the turbulence generator. But the differential pressure in the flow field from outlet to inlet decreases continuously.

Theoretical analyses show that, with the increase of the blade laying angles β , the guiding role that blades were playing for the paper pulp decreases, which causes the torque value produced by the turbulence generator to be increased.

TABLE 2: Targeted values with different blade laying angles.

β	Turbulent kinetic energy K (m^2/s^2)	Torque value ($\text{N}\cdot\text{m}$)	Differential pressure (Pa)
55.8°	131.28%	24.56	5721.83
70.8°	135.72%	25.34	1676.43
90°	140.39%	26.58	-6404.76

Meanwhile the increase of the impact from the blades to the medium makes the flow more complicated, which results in a stronger turbulence flow. When blade laying angle β becomes small, the axial thrust applied to the paper pulp produced by the blades makes the outlet pressure bigger than the inlet pressure. When β increases to a certain value, the axial thrust will offset the frictional head loss as of the paper pulp flow. There will be no axial thrust when β is 90°, and the frictional loss causes the outlet pressure to become smaller than the inlet pressure.

Based on the results of the numerical simulation, the recommended blade laying angle of the turbulence generator is from 60° to 75°.

6. Conclusions

- (1) We analyzed the principle and the conditions of the fluidization of medium consistency pulp. We established the fluidization expression formulas with the characteristic parameters as variables of the MC pulp pump.
- (2) We established the flow mathematical model inside the shearing chamber and obtained the formula to calculate the blade outlet radius of the turbulence generator.
- (3) We simulated the pulp flow inside the turbulence generator. Blade laying angle of the turbulence generator has a small influence on the gas-liquid separation. But the bigger the blade laying angle is, the nearer the gas-liquid separation field is to the blade front part. And the distribution of the turbulent kinetic energy trends to be well distributed with the increase of the blade laying angles.
- (4) The recommended blade laying angle of the turbulence generator is from 60° to 75°.

Acknowledgment

This paper is supported by high technology project of Jiangsu province, China, ID: SBE201000567, R&D of MC paper pulp pumping system.

References

- [1] Z. Jiankang, X. Zonghua, C. Kefu et al., "Design of turbulence medium consistency pulp pump-ZBJ31," *China Pulp and Paper*, vol. 3, no. 6, pp. 3–8, 1986.
- [2] Q. F. Chen, K. F. Chen, and R. D. Yang, "Study on the structure of turbulent generator of MC centrifugal pump based on CFD," *China Pulp and Paper*, vol. 25, no. 10, pp. 25–27, 2006.
- [3] L. Hong, Z. Wanyi, Z. Rongsheng et al., "Structure characteristics of centrifugal pulp pump," *China Pulp and Paper*, vol. 22, no. 4, pp. 38–40, 2003.
- [4] C. Qifeng, C. Kefu, Y. Rendang et al., "Study on the fluidized characteristics of medium-consistency pulp suspensions," *Journal of China Pulp and Paper*, vol. 18, no. 12, pp. 148–150, 2003.
- [5] G. Hemstrom, K. Moller, and B. Norman, "Boundary layer studies in pulp suspension flow," *Tappi*, vol. 59, no. 7, pp. 115–118, 1976.
- [6] S. Wence, *Engineering Fluid Mechanics*, Dalian University of Technology Press, Dalian, China, 2004.
- [7] G. G. Duffy, K. Moller, P. F. W. Lee et al., "Design correlations for groundwood pulps and the effects of minor variables on pulp suspension flow," *Appita*, vol. 27, no. 5, p. 327, 1974.
- [8] J. Gullichsen and E. Harkonen, "Medium consistency technology—1. Fundamental data.," *Tappi*, vol. 64, no. 6, pp. 69–72, 1981.
- [9] C. Kefu, *Technology and Equipment of Medium-High-Consistency Pulp*, South China University of Technology Press, Guangzhou, China, 1994.
- [10] L. Hong, G. Gweihao, F. Jianguo et al., "Experimental study on medium consistency centrifugal pulp pump," *China Pulp and Paper*, vol. 27, no. 2, pp. 71–72, 2008.
- [11] C. Zhiping, Z. Xuwen, and L. Xinghua, *Mixing and Mixing Equipment Application Manual*, Chemical Industry Press, Beijing, China, 2004.
- [12] C. Qifeng, *Study on medium-consistency pulp suspension and CFD application*, Ph.D. dissertation, South China University of Technology, Guangzhou, China, 2005.
- [13] G. Z. Zhou, L. T. Shi, and Y. C. Wang, "Computational fluid dynamics progress in stirred tank reactors," *Chemical Engineering (China)*, vol. 32, no. 3, p. 28, 2004.
- [14] H. Sun, W. Wang, and Z. Mao, "Numerical simulation of whole three-dimensional flow field in stirred tank with anisotropic turbulence model," *Journal of Chemical Industry and Engineering (China)*, vol. 53, no. 11, pp. 1153–1159, 2002.



Hindawi

Submit your manuscripts at
<http://www.hindawi.com>

