

ILC CRYOGENIC SYSTEMS REFERENCE DESIGN

Cite as: AIP Conference Proceedings **985**, 1565 (2008); <https://doi.org/10.1063/1.2908522>

Published Online: 27 March 2008

T. J. Peterson, M. Geynisman, A. Klebaner, V. Parma, L. Tavian, and J. Theilacker



View Online



Export Citation

ARTICLES YOU MAY BE INTERESTED IN

[Cryogenic system for the Cryomodule Test Facility at Fermilab](#)

AIP Conference Proceedings **1573**, 179 (2014); <https://doi.org/10.1063/1.4860699>

[The ESS elliptical cavity cryomodules](#)

AIP Conference Proceedings **1573**, 639 (2014); <https://doi.org/10.1063/1.4860762>

[Status of the ESS cryogenic system](#)

AIP Conference Proceedings **1573**, 633 (2014); <https://doi.org/10.1063/1.4860761>



Lock-in Amplifiers

Zurich Instruments

Watch the Video

ILC CRYOGENIC SYSTEMS REFERENCE DESIGN

T. J. Peterson¹, M. Geynisman¹, A. Klebaner¹, V. Parma², L. Tavian², J. Theilacker¹

¹Fermi National Accelerator Laboratory
Batavia, Illinois 60510, USA

²CERN
CH-1211 Geneva 23, Switzerland

ABSTRACT

A Global Design Effort (GDE) began in 2005 to study a TeV scale electron-positron linear accelerator based on superconducting radio-frequency (RF) technology, called the International Linear Collider (ILC). In early 2007, the design effort culminated in a reference design for the ILC, closely based on the earlier TESLA design. The ILC will consist of two 250 GeV linacs, which provide positron-electron collisions for high energy physics research. The particle beams will be accelerated to their final energy in superconducting niobium RF cavities operating at 2 kelvin. At a length of about 12 km each, the main linacs will be the largest cryogenic systems in the ILC. Positron and electron sources, damping rings, and beam delivery systems will also have a large number and variety of other superconducting RF cavities and magnets, which require cooling at liquid helium temperatures. Ten large cryogenic plants with 2 kelvin refrigeration are envisioned to cool the main linacs and the electron and positron sources. Three smaller cryogenic plants will cool the damping rings and beam delivery system components predominately at 4.5 K. This paper describes the cryogenic systems concepts for the ILC.

KEYWORDS: cryogenics, superconductivity, particle accelerator, linear collider

INTRODUCTION

The International Linear Collider (ILC) will consist of two 250 GeV linear accelerators (linacs), which provide positron-electron collisions for high energy physics research [1]. The ILC main linacs will accelerate electron and positron beams to their final energy in superconducting, niobium, radio frequency (RF) cavities operating at 2 kelvin. At a length of about 12 km each, the main linacs will be the largest cryogenic systems in the ILC, but the positron and electron sources, damping rings, Ring to Main Linac

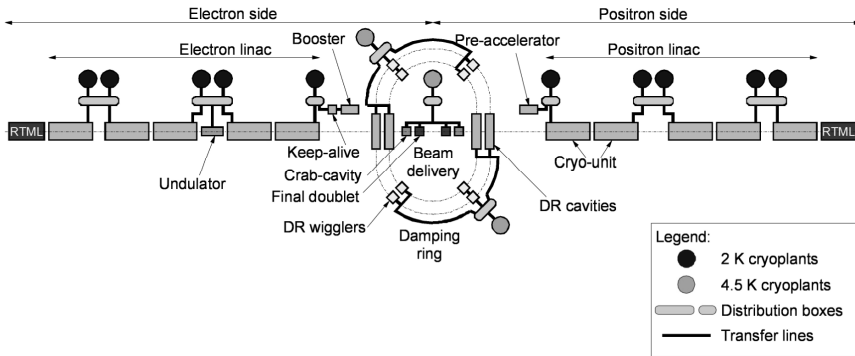

FIGURE 1. The overall layout concept for the cryogenic systems.

(RTML), and beam delivery systems also have a large number and variety of liquid helium temperature superconducting RF cavities and magnets. FIGURE 1 illustrates the concept for the cryogenic system arrangement in ILC. Ten large cryogenic plants with 2 kelvin refrigeration cool the main linacs subdivided into cryogenic units, RTML and the electron and positron sources. Three smaller cryogenic plants with mostly 4.5 K loads cool the damping rings and beam delivery system.

In addition to the 1.3 GHz RF cavities in the main linacs, the ILC has 1.3 GHz superconducting RF cavities in the sources and RTML, 650 MHz superconducting RF in the damping rings, and 3.9 GHz RF in the beam delivery areas. TABLE 1 summarizes the numbers of various types of superconducting RF modules in the ILC.

Although the RF modules listed in TABLE 1 dominate the ILC cryogenic systems, there are a variety of superconducting (SC) magnets. As listed in TABLE 1, 644 1.3 GHz modules contain SC magnets. For positron production, the electron linac includes about 290 meters of SC helical undulators. The Damping Rings have 8 strings of superconducting wiggler magnets, and there are special SC magnets in the sources, RTML, and beam delivery system.

TABLE 1. Superconducting RF modules in the ILC

Cryomodules	8-cavity 1 quad	9-cavity no quad	8-cavity 2-quad	6-cavity 6-quad	1300 MHz	1-cavity 650 MHz	2-cavity 3900 MHz
Main Linac e-	282	564			846		
Main Linac e+	278	556			834		
RTML e-	18	30			48		
RTML e+	18	30			48		
e- source	24				24		
e+ booster	12		6	4	22		
e+ Keep Alive	2				2		
e- damping ring						18	
e+ damping ring						18	
beam delivery system							2
TOTAL	634	1180	6	4	1824	36	2

MAIN LINAC CRYOGENIC SYSTEM

In cryogenic system design, it is important to view the cooled devices as part of the thermal system. Cryogenic system integration with accelerator components is particularly important in the main linacs, where we are considering cooled lengths of over 2 km.

Main linac cryogenic modules each containing eight (with magnet package) or nine (without magnet package) nine-cell niobium cavities, cold helium pipes, and thermal shields are the dominant load to be cooled. The ILC cryomodule design for the 1.3 GHz RF is based on the TESLA Test Facility (TTF) type III design [2] which contains all the cryogenic pipework inside its vacuum enclosure. There are approximately 23 km of 1.3 GHz cryomodules including main linacs, RTML, and sources.

The cryogenic unit cooling scheme (FIGURE 2) consists of long series of modules cooled in series. Like for the TESLA cryogenic concept [3], saturated He II cools RF cavities at 2 K, and helium gas-cooled shields intercept thermal radiation and thermal conduction at 5 - 8 K and at 40 - 80 K. A two-phase header (liquid helium supply and vapor return) connects to each helium vessel and connects to the major pumping return line (Line B) once per module. A small diameter warm-up/cool-down line connects the bottoms of the He vessels.

A subcooled helium supply line (Line A) connects to the two-phase line via a Joule-Thomson valve once per “string” (typically 12 modules). Saturated superfluid helium flows through the two-phase header over the entire length of the 12 module string for filling the cavities and phase separators located at both ends of the string. The first phase separator is used to stabilize the saturated liquid produced during the final expansion. The second phase separator is used to recover the excess of liquid, which is vaporized by a heater. At the interconnection of each cryomodule, the two-phase header is connected to the pumping return line. The 5 K and 40 K heat intercepts and radiation screens are cooled in series through an entire cryogenic unit of up to 2.5 km in length.

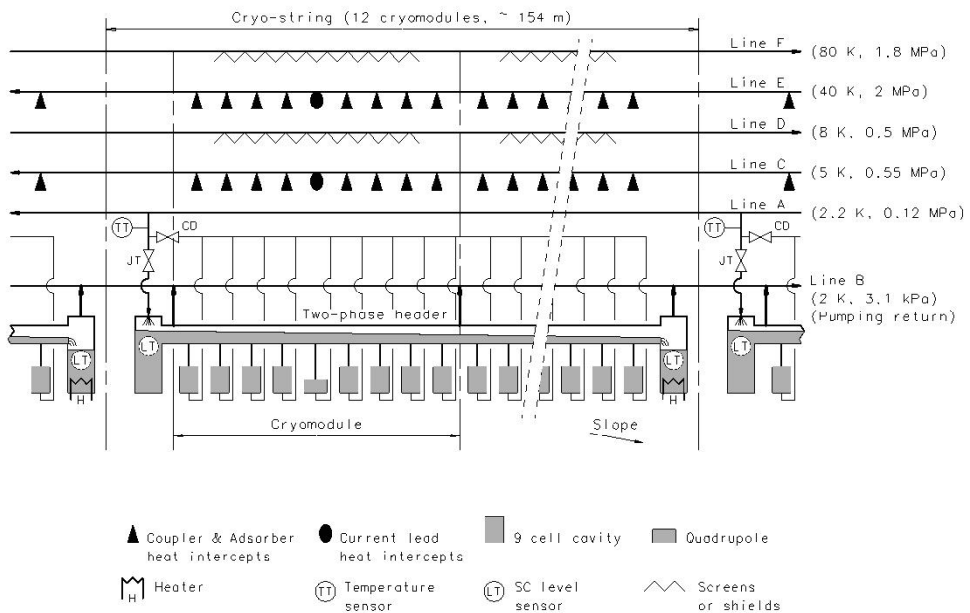

FIGURE 2. ILC main linac cryogenic string

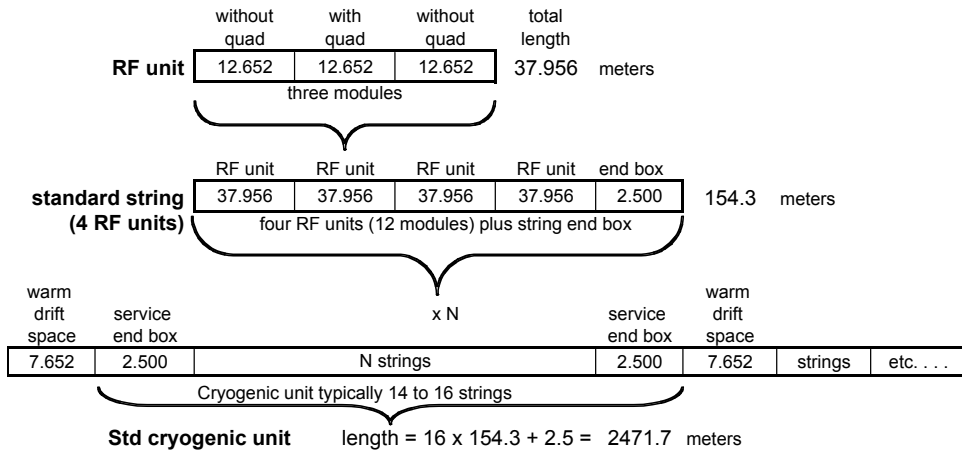

FIGURE 3. Division of main linac into cryogenic strings

The division of the main linacs into cryogenic units is driven by various plant size limits and a practical size for the low pressure pumping return line. A cryogenic plant of 25 kW equivalent 4.5 K capacity is a practical limit due to industrial production for heat exchanger sizes and over-the-road shipping size restrictions. Cryomodule piping pressure drops also start to become rather large with more than 2.5 km distances. Practical plant size and gas return line pressure drop limits are reached with 192 modules in a 16-string cryogenic unit, 2.47 km long. Five cryogenic units divide each main linac conveniently for placing the undulators at 150 GeV. FIGURE 3 illustrates the division of the main linac into strings and units.

ILC MAIN LINAC CRYOMODULES

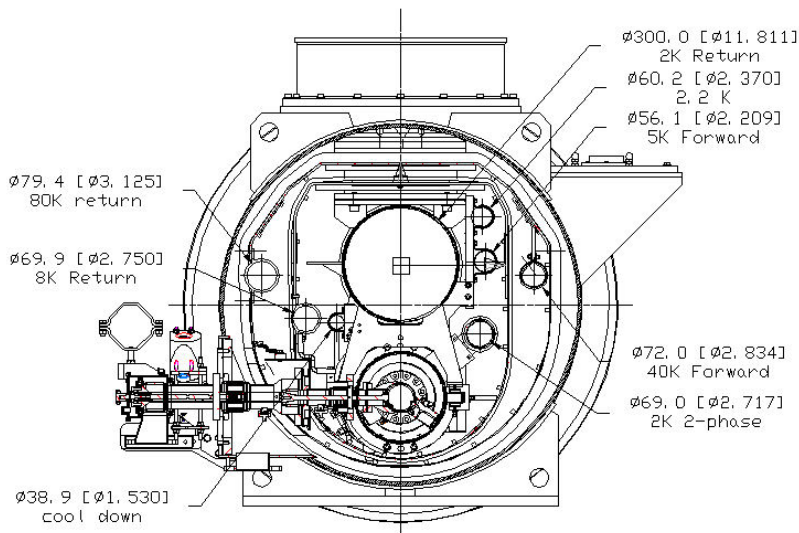

FIGURE 4. Main linac cryomodule cross-section showing pipe sizes and temperature levels.

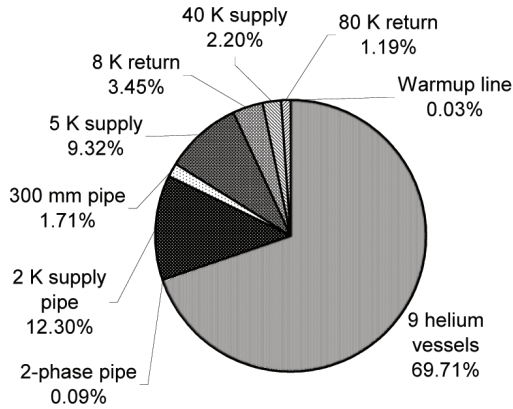

FIGURE 5. Helium mass in a module.

The large flow rates over distances of up to 2.5 km require careful pipe sizing and pressure drop optimization. Calculations were performed for a typical ILC cryogenic unit to verify that variations in pressure and temperatures stay within the design limits. Also, calculations were performed for the loss of vacuum. As the design of the ILC cryogenic system closely resembles the design of TESLA, it is possible to re-use most of the investigation techniques and solutions previously done for TESLA [4]. Calculations show that the 300 mm gas return pipe can support venting of the entire 2 K helium inventory of a 12-module string back to the cryogenic plant. Issues of availability of warm gas storage at the cryogenic plant, operation of beam vacuum valves and recovery of the entire cryogenic unit should be further studied. At least on the scale of one ILC cryomodule the effect of the break down of the insulation vacuum and the beam vacuum should be studied in a real time experiment.

As illustrated in FIGURE 5, most of the helium inventory consists of the liquid helium which bathes the RF cavities in the helium vessels. The total helium inventory in ILC will be roughly equal to that of the LHC at CERN, about 650,000 liquid liters, or about 100 metric tons.

TABLE 2. Main Linac helium inventory

Volumes		Helium (liquid liters equivalent)	Tevatron equivalents	LHC equivalents	Approximate inventory cost (K\$)
One module		346.1			
String	12 modules	4,153.3	0.1		12.46
Cryogenic unit	14-16 strings	62,991.5	1.0	0.1	188.97
ILC main linacs	2x5 cryo units	630,260.9	10.5	0.8	1890.78

SOURCES, DAMPING RINGS, AND BEAM DELIVERY SYSTEMS

Electron and positron sources each include just over 20 SRF modules containing 1.3 GHz RF cavities cooled to 2 kelvin (TABLE 1). The sources also include several superconducting magnets, as well as about 290 meters of superconducting undulators, cooled by one of the cryogenic plants in the electron linac. The electron and positron source linacs are also cooled from main linac cryogenic plants, as illustrated in FIGURE 1.

The damping rings are two accelerator rings, one for electrons and one for positrons, in one tunnel of about 6.7 km circumference. Damping ring cryogenic loads, in total for both rings, include eight strings of 4.5 kelvin superconducting wigglers, four strings of 4.5 kelvin 650 MHz cryomodules, associated cryogenic distribution systems, and 70 K thermal shields for all of these. Two cryogenic plants serve the damping rings. Note that with the damping ring tunnel approximately the same circumference as the Tevatron and HERA tunnels, the damping rings cryogenic system is comparable in scale to the Tevatron or HERA cryogenic systems, although smaller in cooling capacity.

The beam delivery system has one 3.9 GHz cryomodule (containing two cavities) on each side of the interaction point, superconducting final focus quadrupoles, and other special superconducting magnets spaced several hundred meters from the IR. One cryogenic plant serves both sides of the interaction region. This plant could also serve the cryogenic needs of the detectors, but that aspect of these cryogenic systems is not considered here.

HEAT LOADS AND CRYOGENIC PLANT POWER

TABLE 3 shows the predicted heat load for a typical main linac cryogenic unit. This table lists the “uncertainty factor” and “overcapacity factor”, which are multipliers of the estimated heat loads. These are used to estimate a total required cryogenic plant capacity as follows. Installed cryogenic capacity = $F_o \times (Q_d \times F_{ud} + Q_s \times F_{us})$, where F_o is overcapacity for control, off design operation and seasonal temperature variations. F_{ud} is the uncertainty factor on the dynamic heat load estimate, F_{us} the uncertainty factor on static heat load. Q_d is predicted dynamic heat load, and Q_s is predicted static heat load. Note also that cryogenic plant “Carnot” efficiency is assumed to be 28% at the 40 to 80 K level and 24% at the 5 to 8 K temperature level. The efficiency at 2 K is only 20%, however, due to the additional inefficiencies associated with producing refrigeration below 4.2 kelvin. All of these efficiencies are in accordance with recent industrial conceptual design estimates.

A similar analysis has been done for the sources, damping rings, and beam delivery system in order to estimate size requirements for each. (RTML cooling is included with the main linac.) TABLE 4 lists the estimated heat loads and required cryogenic plant size for the damping rings.

TABLE 3. Main linac heat loads and cryogenic plant size.

		40 K to 80 K	5 K to 8 K	2 K
Predicted module static heat load	(W/module)	59.19	10.56	1.70
Predicted module dynamic heat load	(W/module)	94.30	4.37	9.66
Number of modules per cryo unit (8-cavity modules)		192.00	192.00	192.00
Non-module heat load per cryo unit	(kW)	1.00	0.20	0.20
Total predicted heat per cryogenic unit	(kW)	30.47	3.07	2.38
Heat uncertainty factor on static heat (Fus)		1.10	1.10	1.10
Heat uncertainty factor on dynamic heat (Fud)		1.10	1.10	1.10
Efficiency (fraction Carnot)		0.28	0.24	0.22
Efficiency in Watts/Watt	(W/W)	16.45	197.94	702.98
Overcapacity factor (Fo)		1.40	1.40	1.40
Overall net cryogenic capacity multiplier		1.54	1.54	1.54
Heat load per cryogenic unit including Fus, Fud, and Fo	(kW)	46.92	4.72	3.67
Installed power	(kW)	771.72	934.91	2577.65
Installed 4.5 K equiv	(kW)	3.53	4.27	11.78
Percent of total power at each level		18.0%	21.8%	60.2%
Total operating power for one cryo unit based on predicted heat (MW)			3.34	
Total installed power for one cryo unit (MW)			4.28	
Total installed 4.5 K equivalent power for one cryo unit (kW)			19.57	

TABLE 4. Damping ring cryogenics

For each cryogenic plant (of two total)

Total predicted 4.5 K heat	(W)	1660
Total predicted 4.5 K liquid production (for current leads)	(grams/sec)	0.80
Total predicted 70 K heat	(W)	5080
Uncertainty and overcapacity (total combined) margin		1.54
Installed power	(MW)	1.13
Cryogenic plant capacity (converted to 4.5 K equiv)	(kW)	3.45

TABLE 5 summarizes the required capacities of the cryogenic plants for the different area systems. The maximum required plant capacities (equivalent at 4.5 K) are comparable with the present state of the art cryogenic plants used in the Large Hadron Collider [3]. Total installed power for the cryogenic system is 47 MW, with an expected typical operating power of 37 MW.

If the tunnel is located near the surface, i.e. with depth of access shafts smaller than 30 m, the entire cryogenic plant can be installed above ground. If the tunnel is deep, certain components must be installed at tunnel level because of the hydrostatic pressure head.

TABLE 5. ILC cryogenic plant sizes (Sources listed separately here, but may be combined with Main Linac.)

Area	Number of plants	Installed plant size (each) (MW)	Installed total power (MW)	Operating power (each) (MW)	Operating total power (MW)
Main Linac + RTML	10.00	4.28	42.80	3.34	33.40
Sources	2.00	0.59	1.18	0.46	0.92
Damping Rings	2.00	1.13	2.26	0.88	1.76
BDS	1.00	0.41	0.41	0.33	0.33
TOTAL			46.65		36.41

CONCLUSIONS

These ILC cryogenic system concepts provides a baseline for further design and development work. Open design issues remain, due both to the nature of superconducting RF and the scope of the ILC. Three major areas of work during the upcoming engineering design phase will be cryogenic plant cycle design, maintenance and reliability, and options for grouping major surface components.

We will learn much about large-scale, 2-kelvin cryogenics from two projects which will precede ILC. XFEL [5] at DESY will be comparable to one ILC main linac cryogenic unit and will provide important experience regarding operation of long strings of ILC-style cryomodules. LHC [6] at CERN is a 2-kelvin cryogenic system comparable in size to that foreseen for ILC. Thus, although the LHC cryogenic system differs from ILC in many ways, and X-FEL also differs from ILC, both will provide valuable experience and information about operation of very large-scale 2-kelvin cryogenics.

In summary, the ILC cryogenic system will permeate the full 32 km of linacs, damping rings, and beam delivery areas in the ILC. Installed power of about 47 MW will provide over 30 kW of cooling at 2 kelvin plus refrigeration at other, intermediate temperatures. Although the cryogenic system will make use of existing, industrially produced technology, some unique problems and features will be addressed during the engineering design phase of ILC.

ACKNOWLEDGMENTS

This work is supported by the U. S. Department of Energy under contract No DE-AC02-07CH11359. The authors thank Chris Adolphsen and Nikolay Solyak for main linac heat load guidance and design information, Yuri Orlov for cryomodule information, and the various ILC reference design technical and area leaders for their collaborative efforts.

REFERENCES

1. "ILC Reference Design Report," April, 2007, available at <http://www.linearcollider.org/cms/>
2. "TESLA Technical Design Report," published by DESY, Notkestrasse 85, 22607 Hamburg, March, 2001.
3. Horlitz, G., Peterson, T., and Trines, D., "The TESLA 500 Cryogenic System Layout," in *Advances in Cryogenic Engineering* 41A, edited by P. Kittel et al., Plenum, New York, 1996, pp. 911-920.
4. Petersen, B., Wolf, S., "Numerical Simulations of Possible Fault Conditions in the Cryogenic Operation of the TTF/FEL – and Tesla Linear Accelerator", *Proceedings of the 18th International Cryogenic Engineering Conference (ICEC18)*, Mumbai, India, 2000.
5. "XFEL Technical Design Report," published by the DESY XFEL Project Group, Notkestrasse 85, 22607 Hamburg, July, 2006. (http://xfel.desy.de/tdr/index_eng.html)
6. Lebrun, Ph., "Cryogenics for the Large Hadron Collider," LHC Project Report 338, presented at the 16th International Conference on Magnet Technology, 1999, Ponte Vedra Beach, FL.