

**INTELLIGENT POWER SYSTEM PROTECTION
DATA MANAGEMENT**

NURULHUDA BINTI HJ HANZAH

**A thesis submitted in
fulfillment of the requirement for the award of the
Master Of Electrical Engineering**

**Faculty Of Electrical & Electronic Engineering
Universiti Tun Hussien Onn Malaysia**

DECEMBER 2013

ABSTRACT

The Power Flow is the most important issue to ensure an efficient yet affordable system. To maintain a low failure electrical breakdown or blackout analysis of faults leads to appropriate protection settings which can be computed in order to select suitable fuse, circuit breaker size and type of relay. The studies and detection of these faults is necessary to ensure that the reliability and stability of the power system do not suffer a decrement as a result of a critical event such a fault. This project will analyze a power systems under fault conditions.

CONTENTS

DECLARATION

ACKNOWLEDGEMENT

ABSTRACT	iii
CONTENTS	iv
LIST OF TABLE	viii
LIST OF FIGURES	x
LIST OF SYMBOLS AND ABBREVIATIONS	xii

CHAPTER 1 : INTRODUCTION

1.1	Design of protection	2
1.2	Equipment of protection	3
1.3	System protection	3
1.4	Problem statement	4
1.5	Objective	4

CHAPTER 2 : LITERATURE REVIEW

2.1	Introduction	5
-----	--------------	---

CHAPTER 3 : METHODOLOGY

3.1	PowerWorld Simulator Network Case	10
3.2	System Modelling via PowerWorld Simulator	10
3.3	Power Flow Analysis Voltage Control Simulator	11
3.4	Formulation of Power Flow	12
	3.4.1 Inner power flow loop	12
	3.4.2 Nonlinear power flow equations	12
3.5	Power flow analysis	12
	3.5.1 Positive sequence components	13
	3.5.2 Negative sequence components	13
	3.5.3 Zero sequence components	14
3.6	Fault analysis for power system	17
	3.6.1 Three phase fault	17
	3.6.2 Single line-to-line fault	20
	3.6.3 Line-to-line fault	22
	3.6.4 Double line-to-ground fault	24

CHAPTER 4 : DATA ANALYSIS AND RESULTS

4.1	Power network model	29
4.2	Power balance in power system	30
4.3	Normalization of voltage measured in per unit instead of V	31
4.4	Power flow variables and parameters	32
4.5	Security limits in power system operating	33
	4.5.1 Branch loading limits	33
	4.5.2 Bus voltage limits	33
4.6	Fault analysis	34
	4.6.1 Three phase fault	34
	4.6.2 Single line-to-ground fault	35
	4.6.3 Line-to-line fault	35
	4.6.4 Double line-to-ground fault	36

4.7	Fault analysis when increasing the load on Bus 3 from 100 MW to 300 MW	37
4.7.1	Three phase fault	37
4.7.2	Single line-to-ground fault	38
4.7.3	Line-to-line fault	38
4.7.4	Double line-to-ground fault	39
4.8	Fault analysis when increasing the load on Bus 3 from 300 MW to 600 MW	40
4.8.1	Three phase fault	40
4.8.2	Single line-to-ground fault	41
4.8.3	Line-to-line fault	41
4.8.4	Double line-to-ground fault	42
4.9	Fault analysis when increasing the load on Bus 3 from 600 MW to 900 MW	43
4.9.1	Three phase fault	43
4.9.2	Single line-to-ground fault	44
4.9.3	Line-to-line fault	44
4.9.4	Double line-to-ground fault	45
4.10	Hand calculation on Bus 3 at 100 MW	46
4.10.1	Three phase fault	46
4.10.2	Single line-to-ground fault	48
4.10.3	Line-to-line fault	54
4.10.4	Double line-to-ground fault	60
4.11	Results and discussion	67
4.11.1	Three phase fault	67
4.11.2	Single line-to-ground fault	68
4.11.3	Line-to-line fault	68
4.11.4	Double line-to-ground fault	69

CHAPTER 5 : CONCLUSION

5.1 Fault analysis visualization of results 71

5.2 Conclusion 72

REFERENCES 74

LIST OF TABLES

4.1	Bus voltage for three phase fault at load 100MW	34
4.2	Fault current for three phase at load 100MW	34
4.3	Bus voltage for single line-to-ground fault at load 100MW	35
4.4	Fault current for single line-to-ground at load 100MW	35
4.5	Bus voltage for line-to-line fault at load 100MW	35
4.6	Fault current for line-to-line at load 100MW	35
4.7	Bus voltage for double line-to-ground fault at load 100MW	36
4.8	Fault current for double line-to-ground at load 100MW	36
4.9	Bus voltage for three phase fault at load 300MW	37
4.10	Fault current for three phase at load 300MW	38
4.11	Bus voltage for single line-to-ground fault at load 300MW	38
4.12	Fault current for single line-to-ground at load 300MW	38
4.13	Bus voltage for line-to-line fault at load 300MW	38
4.14	Fault current for line-to-line at load 300MW	39
4.15	Bus voltage for double line-to-ground fault at load 300MW	39
4.16	Fault current for double line-to-ground at load 300MW	39
4.17	Bus voltage for three phase fault at load 600MW	40
4.18	Fault current for three phase at load 600MW	41
4.19	Bus voltage for single line-to-ground fault at load 600MW	41
4.20	Fault current for single line-to-ground at load 600MW	41
4.21	Bus voltage for line-to-line fault at load 600MW	41
4.22	Fault current for line-to-line at load 600MW	42
4.23	Bus voltage for double line-to-ground fault at load 600MW	42

LIST OF TABLES

4.24	Fault current for double line-to-ground at load 600MW	42
4.25	Bus voltage for three phase fault at load 900MW	43
4.26	Fault current for three phase at load 900MW	44
4.27	Bus voltage for single line-to-ground fault at load 900MW	44
4.28	Fault current for single line-to-ground at load 900MW	44
4.29	Bus voltage for line-to-line fault at load 900MW	44
4.30	Fault current for line-to-line at load 900MW	45
4.31	Bus voltage for double line-to-ground fault at load 900MW	45
4.32	Fault current for double line-to-ground at load 900MW	45

LIST OF FIGURE

3.1	Methodology of creating diagram of power system	11
3.2	Simulator solution methodology	11
3.3	Positive sequence components	13
3.4	Negative sequence components	14
3.5	Zero sequence components	14
3.6	Diagram of three phase fault	17
3.7	Sequence network diagram of three phase fault	18
3.8	Diagram of single line-to-ground fault	20
3.9	Sequence network diagram of single line-to-ground fault	20
3.10	Diagram of line-to-line fault	22
3.11	Sequence network diagram of line-to-line fault	23
3.12	Diagram of double line-to-ground fault	24
3.13	Sequence network diagram of double line-to-ground fault	25
4.1	Diagram of 5 Bus system	29
4.2	Diagram of 5 Bus system showing active power (MW) and normalized Voltage (pu)	30
4.3	Power flow list	32
4.4	Power flow diagram when Bus 3 at 300MW	37
4.5	Power flow diagram when Bus 3 at 600MW	40
4.6	Power flow diagram when Bus 3 at 900MW	43

LIST OF FIGURE

4.7	Three phase fault	67
4.8	Single line-to-ground fault	68
4.9	Line-to-line fault	68
4.10	Double line-to-ground fault	69
5.1	Diagram of 5 bus system power flow	71

LIST OF SYMBOLS AND ABBREVIATIONS

P	–	Power
Q	–	Reactive power
V	–	Voltage
I	–	Current
$ V $	–	Voltage magnitude
θ	–	Phase angle
Hz	–	Hertz
Cos	–	Cosine
Sin	–	Sine
MW	–	Mega Watt
KV	–	Kilovolt
(F)	–	Fault
AGC	–	Automatic generation control

CHAPTER 1

INTRODUCTION

Different types of protections are installed to protect the equipment in an electric power system. Their task is to disconnect failed or overloaded equipment or parts of the system to avoid unnecessary damages on equipment and personnel. The purpose is also to limit the impact of failures on the parts of the system that have not failed. Special types of protection are the “system protections”. Their task is to prevent collapse (black out) of the system or parts of the system.

An intensive development of protections based on modern information technology is going on both regarding hardware and software. On the hardware side microprocessors have been used over a long time to implement different functions in the protections, and with the recent developments more and more complicated functions can be implemented in a reliable way. Powerful methods like signal processing, state estimation, and “artificial intelligence”, are being integrated into the protections. In general the functions which earlier were handled with separate relays are increasingly being integrated with other functional units for control and supervision.

It is cost prohibitive to make power systems 100 percent safe or 100 percent reliable. Risk assessments are necessary for determining acceptable levels of danger from injury or cost resulting from damage. Protective relays are electronic or electromechanical devices that are designed to protect equipment and limit injury caused by electrical failures. Relays are only one part of power system protection, because protection must be designed into all aspects of power system facilities. Protective relays cannot prevent faults; they can only limit the damage caused by faults. A fault is any condition that causes abnormal operation for the power system or equipment serving the power system. Faults include but are not limited to: short- or low-impedance circuits, open circuits, power swings, overvoltages, elevated temperature, off-nominal frequency operation, and failure to operate.

Power system protection must determine from measurements of currents and/or voltages whether the power system is operating correctly. Three elements are critical for protective relays to be effective: measurements, data processing, and control.

In order to prevent such an event, power system fault analysis was introduced. The process of evaluating the system voltages and currents under various types of short circuit is called fault analysis which can determine the necessary safety measures and the required protection system. It is essential to guarantee the safety of public.

1.1 Design of Protection

A protection for an electric power system comprises the following parts:

- *Measurement device* with current- and/or voltage transformers and other sensors measuring the relevant quantities.
- *Relay* which when certain conditions are fulfilled sends signals to a circuit breaker or another switching device. This relay was earlier a separate unit, but can in modern protections be a part of a larger unit for protection, supervision and control.
- *Circuit breakers* which execute the given instruction(s) from the relay.

- *Telecommunication system* is mainly used at distance (line) protection to get a faster and more reliable performance.
- *Power supply systems* which shall secure the power supply to the protection system, even with faults in the system.

1.2 Equipment Protection

The primary function of power system protection is to limit damage to power system apparatus. Whether the fault or abnormal condition exposes the equipment to excessive voltages or excessive currents, shorter fault times will limit the amount of stress or damage that occurs. The challenge for protective relays is to extract information from the voltage and current instrumentation that indicates that equipment is operating incorrectly. Although different faults require different fault detection algorithms, the instrumentation remains the same, namely voltages and currents.

1.3 System Protections

System protections are special types of protection, the primary task of which is not to isolate failed equipment, but to prevent that the total system large parts of it collapse. System protections often use information from several different points in the system or quantities which can give a reliable diagnosis of the state of the system. These systems often work in a time scale which is considerably longer than the more device oriented protections which were considered earlier, typically several seconds or minutes. An example of a system protection is load shedding. This is used to avoid that the frequency in the system falls below acceptable values if the generation capacity has dropped in the system. The load shedding then disconnects predetermined loads depending on how much and how fast the frequency is falling. Voltage collapse

protection is another system protection, the task of which is to prevent voltage collapse in the system. Load shedding uses only the frequency as input signal, while the voltage collapse protection often uses several different quantities as input signals.

1.4 Problem statement

Many organizations are turning to intelligent power technology to protect their data center. When power generator failures triggered, the company was compelled to pay out millions to their clients. The most rigorous redundancy in servers, storage and networking means nothing if lose the power to run it all, even briefly. If power fluctuates for even a few seconds, data can become corrupted or lost. A brief power disturbance can trigger events that require hours of data recovery time. Invisible power anomalies can damage sensitive components and cause malfunctions in crucial servers and processes and the costs are high.

1.5 Objective:

The objectives of this project are :

1. To study the 5 Bus power system transmission.
2. To develop a system protection of data.
3. To analyze a power systems under fault conditions.

CHAPTER 2

LITERITURE REVIEW

Bruce G. Bailey [1] says the power monitoring system described uses microprocessor technology to provide protection, real-time status displays, event logging and power management and control for industrial AC power distribution and generation systems. The system uses an industrial grade host personal computer to monitor various device communication systems. Each device communication system consists of a display and monitoring unit connected by a single twisted-pair EIA RS-485 communications interface to microprocessor-controlled power meters, trip units, overcurrent protective relays and/or motor protective relays on power distribution systems. Both metering and protection functions use RMS sensing to properly account for harmonics that distort waveforms.

Mesut Baran and Jinsang Kim [2] developed a method for screening the Power Quality event records and estimating the protection system responded to disturbances. The method identifies the protection devices operated following a disturbance and checks whether there is coordination or malfunction problems with the protection devices involved. In the system, Mesut Baran and Jinsang Kim said the electric utilities

are installing power quality monitors (PQM) at substations to monitor power quality. Distribution substations are the preferred places for PQ monitoring. Whenever a PQM detects any current or voltage variation that is outside the preset threshold, it records all phase current and voltage waveforms. This data is stored in PQM and downloaded and stored in a power quality database (PQDB). The PQ event analysis uses these event records in the PQDB and generates a report that includes a description of disturbance and the system response to the disturbance.

Meanwhile Dr. Z Schreiner, A.J. Middleton and J. Bizjak [3] has adopted a new intelligent mobile approach for secondary systems maintenance, enabling Advanced Data Management together with access to rapid, automatic and reliable testing procedures. The paper describes the solution and how it provides documentation optimization with automatic synchronization of the mobile data throughout the enterprise. The team said the new system enables management and testing of power system protection devices to be carried out by single or multiple users and also from different locations, including switchgears, substations, power plants etc. Mobile working is supported by notebooks with local databases, followed by automatic synchronization after connection to the server via LAN or WAN. Maintenance of modern protection devices must be adapted to existing and future technologies for example the IEC61850. The authors' present new developments in protection testing methodology termed SOR (Stabilization-Operation-Reset). SOR is a standard, simple and vendor-independent test methodology and experienced conducting practical test of SOR for future trends in Mobile Data Management. The Project Team added, the new system must be extremely user friendly and intuitive. The simplicity of the system from the user point of view was seen to be the fundamental issue and also the new system had to be capable to manage protection parameters no matter to the generation, producer and type of the asset. That means that the system is also suitable for legacy devices (electromechanical and analogue protection devices) that do not have a capability to import the protection parameters. As a result, the system had to have the capability of manual input of protection parameters.

Mladen Kezunovic [4] from Texas A&M University, said one issue that did not get adequate attention regarding control and protection of power systems in the past is the data integration and information exchange. The traditional approaches assume that each function such as protection, control, monitoring, and maintenance are supported by a separate infrastructure of recording instruments and/or controllers for obtaining and processing data. With introduction of the new computer-based equipment for control and protection in the mid eighties, the integration of data and information exchange were possible, but not explored. This paper indicates the improvements and benefits that can be obtained by integrating the data and exchanging information among control and protection as well as system-wide monitoring and control functions.

Zhang Hai Yang and Li Shan De [5] discover the key idea to make certain changes to the protection system is respond due to the load changes, such as power failures caused by switching operations or changes in the power system. By referring to the basic principle of protection, adaptive protection automatically adjust the relay to a various protection functions, or changes to more suitable for a given power system conditions. For general protection adaptive capacity and detecting some aspects of complex fault there are some limitations and hardware circuit of microprocessor line protection device. Both hardware and algorithm considers the anti-jamming methods. On the software side, they use new method of frequency measurement, dynamically tracking changes of frequency, real-time adjustment of sampling frequency for sampling and developed the new algorithm in improving data accuracy and simplifying the hardware circuit. The adaptive principle is applied to the microprocessor line protection, adaptive instantaneous overcurrent protection, overcurrent protection principles, to meet the requirements of rapid change operation mode to improve the performance of line protection. Relay protection needs to adapt to frequent changes in the power system operating mode, correctly remove various failure and equipment, and adaptive relay protection maintains a system of standard features in case of parameter changes. The simulation results show that it is an effective adaptive method.

Takaya Shono, Katsuhiko Sekiguchi, Tatsuji Tanaka, Member and Shigeki Katayama [6] developed a system which can reduce the total cost of maintenance and management of protection and control equipment. In the system, they have proposed an Intranet Power System which performs supervisory control of a power system using Internet technology and they also have proposed a mobile agent for power system protection and control system as part of the Intranet Power System. In this paper, the Real-Time Mobile Agent Platform (MAP) provides more powerful functions to synchronize between two or more agents in a distributed node, and redundancy to deal with unexpected communication failure. So the agent can now be applied to the power system protection and control system for which real time operation and advanced reliability are required. They said, at present, a Remote Operating and Monitoring System for protection and control equipment has been verified for real use and put into service. However, in order to perform maintenance or event analysis for two or more equipments, it is necessary for the operator to use the terminal (PC) for data collection and analysis, connecting and communicating individually.

Jianxin Tang [7] studies the optimal power flow (OPF) in a power grid using the PowerWorld Simulator for an undergraduate power system course. He discussed the cases of with and without transmission line losses. The results from the simulations are compared to analytical and numerical calculations. The visual results from the simulator allow students to better understand the OPF and how to use the simulator to perform more advanced simulation of power grid.

Fangxing LI and Rui Bo [8] present two small test systems for power system economic studies. The first system is based on the original PJM 5-bus system, which contains data related to real power only because it demonstrates results based on the linearized DC optimal power flow (OPF) model. Fangxing LI and Rui Bo suggests some modification to the original data, as well as new parameters related to reactive power such AC-model-based simulation is possible. The second system is based on the original IEEE 30-bus system, which is an AC system, but it does not have economic data such as

generation costs and transmission network limits. Both of them suggest some reasonable values for generation costs and transmission limits.

CHAPTER 3

METHODOLOGY

3.1 Powerworld Simulator Network Case

PowerWorld is a power system visualization, simulation and analysis tool. This case study contains information such as bus data, generator data and branch data which this information is needful to complete power flow diagram of system. There is a certain information need to fill up without information given in the study case such as rating of transformer that connects to every bus.

3.2 System Modelling via PowerWorld Simulator

Before starting a power flow via PowerWorld Simulator, the system must have the information about the systems element such as generator, transmission lines, transformer and load. The orders in which they are input are shown in Figure 3.1 below.

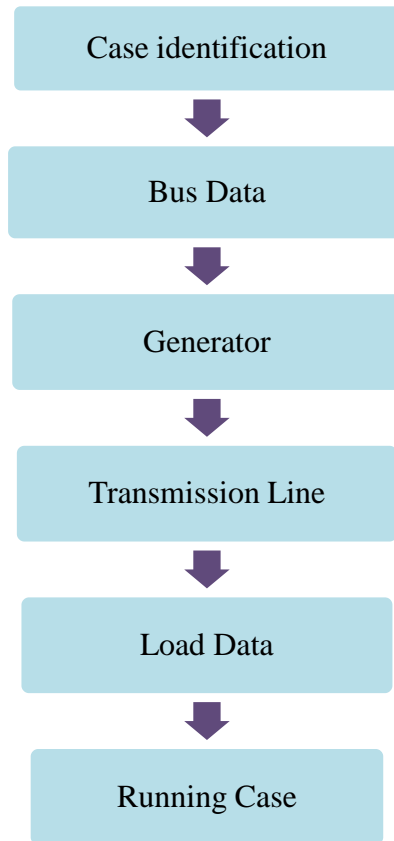

Figure 3.1 Methodology of creating diagram of power system

3.3 Power Flow Analysis and Voltage Control using Simulator

In the Power Flow Analysis, the formulation of the power flow problem is using the Newton's method for solving the power flow. In the PowerWorld Simulator, the simulator actually uses three nested loops to solve the power flow.

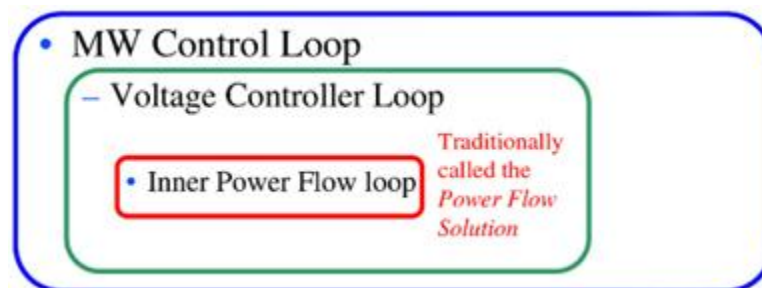

Figure 3.2 Simulator Solution Methodology

3.4 Formulation of Power Flow

3.4.1 Inner Power Flow Loop

The goal is to solve the nonlinear power balance equations for all system buses. For an n bus power system :

$$I = Y_{bus} V \quad (3.1)$$

where;

$I =$ complex vector of current injection in all buses

$V =$ complex vector of voltage at all buses

$Y_{bus} =$ complex n bus admittance matrix

3.4.2 Nonlinear Power Flow Equations

The complex nonlinear power balance equations are :

$$S^* = V \times I \quad (3.2)$$

$$S^* = V^* Y_{bus} \times V \quad (3.3)$$

3.5 Power flow analysis

Power flow (or load flow) analysis provides the steady-state solution of a power network for specific network conditions which include both network topology and load levels.

The power flow solution gives the nodal voltages and phase angles and hence the power injections at all buses and power flows through lines, cables and transformers. It is the basic tool for analysis, operation, and planning of distribution networks. In a power system, each busbar is associated with four quantities. There are the magnitude of voltage ($|V|$) and its angle (θ), real power injection (P) and reactive power injections (Q).

Analyzing any symmetrical fault can be achieved using impedance matrix method or Thevenin's method. Fortescue's theorem suggests that any unbalanced fault can be solved into three independent symmetrical components which differ in the phase sequence. These components consist of a positive sequence, negative sequence and a zero sequence.

3.5.1 Positive Sequence Components

The positive sequence components are equal in magnitude and displayed from each other by 120° with the same sequence as the original phases. The positive sequence currents and voltages follow the same cycle order of the original source. In the case of typical counter clockwise rotation electrical system, the positive sequence phasors are shown in Figure 3.3. The same case applies for the positive current phasors. This sequence is also called the "abc" sequence and usually denoted by the symbol '+' or '1'.

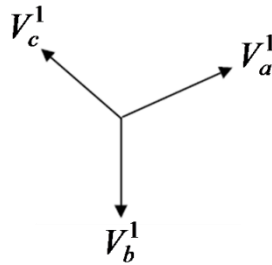

Figure 3.3 Positive sequence components

3.5.2 Negative Sequence Components

This sequence has components that are also equal in magnitude and displayed from each other by 120° similar to the positive sequence components. However, it has an opposite phase sequence from the original system. The negative sequence is identified as the "acb" sequence and usually denoted by the symbol '-' or '2'. The phasors of this sequence are shown in Figure 3.4 where the phasors rotate anti-clockwise. This

sequence occurs only in case of an unsymmetrical fault in addition to the positive sequence components,

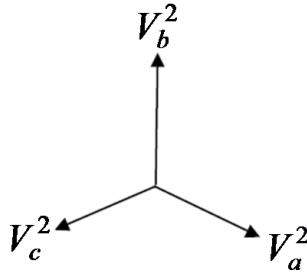

Figure 3.4 Negative sequence components

3.5.3 Zero Sequence Components

In this sequence, its components consist of three phasors which are equal in magnitude as before but with a zero displacement. The phasor components are in phase with each other. This is illustrated in Figure 3.5.

Under an asymmetrical fault condition, this sequence symbolizes the residual electricity in the system in terms of voltages and currents where a ground or a fourth wire exists. It happens when ground currents return to the power system through any grounding point in the electrical system. In this type of faults, the positive and the negative components are also present. This sequence is known by the symbol '0'.

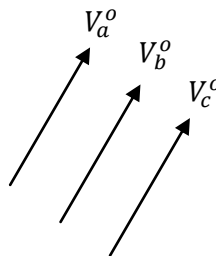

Figure 3.5 Zero sequence components

The following are three sets of components to represent three-phase system voltages as positive, negative and zero components :

$$\begin{aligned} \text{Positive component} &= V_{a1} V_{b1} V_{c1} \\ \text{Negative component} &= V_{a2} V_{b2} V_{c2} \\ \text{Zero component} &= V_{a0} V_{b0} V_{c0} \end{aligned}$$

The addition of all symmetrical components will present the original system phase components V_a , V_b and V_c as seen below :

$$\begin{aligned} V_a &= V_{a0} + V_{a1} + V_{a2} \\ V_b &= V_{b0} + V_{b1} + V_{b2} \\ V_c &= V_{c0} + V_{c1} + V_{c2} \end{aligned} \quad (3.4)$$

The 'a' operator is defined below :

$$a = 1 \angle 0^\circ \quad (3.5)$$

The following relations can be driven as below :

$$\begin{aligned} a^2 &= 1 \angle -120^\circ \\ a^3 &= 1 \angle 0^\circ \end{aligned}$$

From the above definition and using the 'a' operator, it can be translated into a set of equations to represents each sequence :

$$\text{Zero sequence components} : V_{a0} = V_{b0} = V_{c0} \quad (3.6)$$

$$\text{Positive sequence components} : V_{b1} = a^2 V_{a1} \text{ and } V_{c1} = a V_{a1} \quad (3.7)$$

$$\text{Negative sequence components} : V_{b2} = a V_{a2} \text{ and } V_{c2} = a^2 V_{a2} \quad (3.8)$$

The original system phasors V_a , V_b and V_c can be expressed in terms of phase 'a' components. The equation can be written as follows :

$$\begin{aligned} V_a &= V_{a0} + V_{a1} + V_{a2} \\ V_b &= V_{a0} + a^2V_{a1} + aV_{a2} \\ V_c &= V_{a0} + aV_{a1} + a^2V_{a2} \end{aligned} \quad (3.9)$$

Writing the above equations can be accomplished in a matrix form :

$$\begin{pmatrix} V_a \\ V_b \\ V_c \end{pmatrix} = \begin{pmatrix} 1 & 1 & 1 \\ 1 & a^2 & a \\ 1 & a & a^2 \end{pmatrix} \begin{pmatrix} V_{a0} \\ V_{a1} \\ V_{a2} \end{pmatrix} \quad (3.10)$$

Defining A as :

$$A = \begin{pmatrix} 1 & 1 & 1 \\ 1 & a^2 & a \\ 1 & a & a^2 \end{pmatrix} \quad (3.11)$$

The equation (3.10) can be written as :

$$\begin{pmatrix} V_a \\ V_b \\ V_c \end{pmatrix} = A \begin{pmatrix} V_{a0} \\ V_{a1} \\ V_{a2} \end{pmatrix} \quad (3.12)$$

The equation above can be inverted to obtain the positive, negative and zero sequences from the system phasors :

$$\begin{pmatrix} V_{a0} \\ V_{a1} \\ V_{a2} \end{pmatrix} = A^{-1} \begin{pmatrix} V_a \\ V_b \\ V_c \end{pmatrix} \quad (3.13)$$

Where A^{-1} is equal to the following :

$$A^{-1} = \frac{1}{3} \begin{pmatrix} 1 & 1 & 1 \\ 1 & a^2 & a \\ 1 & a & a^2 \end{pmatrix} \quad (3.14)$$

These equations can be applied for the phase voltages and currents. It also can be express for line currents and line-to-line voltages of any power system under fault conditions.

3.6 Fault Analysis in Power System

Fault studies form an important part of power system analysis [11]. The problem consists of determining bus voltages and line currents during various types of faults. Faults in power systems are divided into three-phase balanced faults and unbalanced faults. Different types of unbalanced faults are single line-to-ground fault, line-to-line fault and double line-to-ground fault.[8]

3.6.1 Three Phase Fault

A three phase fault is defined as the simultaneous short circuit across three phases. It occurs infrequently but it is the most severe type of fault encountered. Some of the characteristics of a three phase fault are very large fault current and usually a voltage equals to zero at the site where the fault takes place.

A general representation of a balanced three phase fault is shown in Figure 3.6 where F is the fault point with impedances Z_f and Z_g . Figure 3.7 shows the sequences networks interconnection diagram.

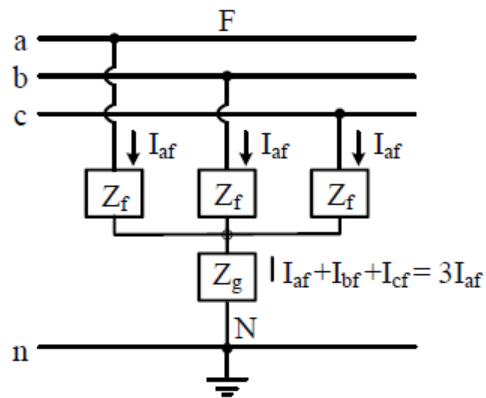

Figure 3.6 Diagram of three phase fault

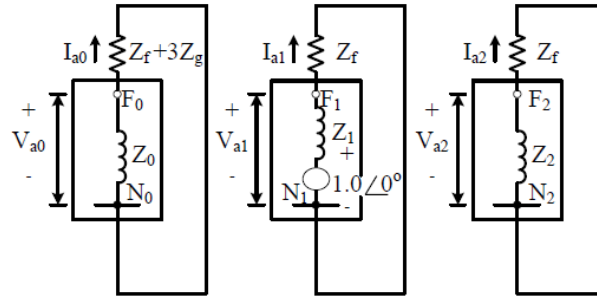

Figure 3.7 Sequence network diagram of balanced three phase fault

From figure 3.7 positive sequence network has an internal voltage source. Therefore, the corresponding currents for each of the sequences can be expressed as

$$\begin{aligned} I_{a0} &= 0 \\ I_{a2} &= 0 \\ I_{a1} &= \frac{1.0 \angle 0^\circ}{Z_1 + Z_f} \end{aligned} \quad (3.15)$$

If the fault impedance Z_f is zero,

$$I_{a1} = \frac{1.0 \angle 0^\circ}{Z_1} \quad (3.16)$$

If the equation is substituted into equation

$$\begin{bmatrix} I_{af} \\ I_{bf} \\ I_{cf} \end{bmatrix} = \begin{bmatrix} 1 & 1 & 1 \\ 1 & a^2 & a \\ 1 & a & a^2 \end{bmatrix} \begin{bmatrix} 0 \\ I_{a1} \\ 0 \end{bmatrix} \quad (3.17)$$

Solving equation 3.17

$$\begin{aligned} I_{af} &= I_{a1} = \frac{1.0 \angle 0^\circ}{Z_1 + Z_f} \\ I_{bf} &= a^2 I_{a1} = \frac{1.0 \angle 240^\circ}{Z_1 + Z_f} \\ I_{cf} &= a I_{a1} = \frac{1.0 \angle 120^\circ}{Z_1 + Z_f} \end{aligned} \quad (3.18)$$

Since the sequence networks are short-circuited over their own fault impedance

$$\begin{aligned} V_{a0} &= 0 \\ V_{a1} &= Z_f I_{a1} \\ V_{a2} &= 0 \end{aligned} \quad (3.19)$$

If the equation is substituted into Equation

$$\begin{bmatrix} V_{af} \\ V_{bf} \\ V_{cf} \end{bmatrix} = \begin{bmatrix} 1 & 1 & 1 \\ 1 & a^2 & a \\ 1 & a & a^2 \end{bmatrix} \begin{bmatrix} 0 \\ V_{a1} \\ 0 \end{bmatrix} \quad (3.20)$$

Therefore,

$$\begin{aligned} V_{af} &= V_{a1} = Z_f I_{a1} \\ V_{bf} &= a^2 V_{a1} = Z_f I_{a1} \angle 240^\circ \\ V_{cf} &= a V_{a1} = Z_f I_{a1} \angle 120^\circ \end{aligned} \quad (3.21)$$

The line-to-line voltages are

$$\begin{aligned} V_{ab} &= V_{af} - V_{bf} = V_{a1}(1 - a^2) = \sqrt{3} Z_f I_{a1} \angle 30^\circ \\ V_{bc} &= V_{bf} - V_{cf} = V_{a1}(a^2 - a) = \sqrt{3} Z_f I_{a1} \angle -90^\circ \\ V_{ca} &= V_{cf} - V_{af} = V_{a1}(a - 1) = \sqrt{3} Z_f I_{a1} \angle 150^\circ \end{aligned} \quad (3.22)$$

If Z_f is equal to zero,

$$\begin{aligned} I_{af} &= \frac{1.0 \angle 0^\circ}{Z_1} \\ I_{bf} &= \frac{1.0 \angle 240^\circ}{Z_1} \\ I_{cf} &= \frac{1.0 \angle 120^\circ}{Z_1} \end{aligned} \quad (3.23)$$

The phase voltage becomes,

$$V_{af} = V_{bf} = V_{cf} = 0 \quad (3.24)$$

The line voltages,

$$V_{a0} = V_{a1} = V_{a2} = 0 \tag{3.25}$$

3.6.2 Single Line-To-Ground Fault

The single line-to-ground fault is referred as short circuit fault and it occurs when one conductor falls to ground or makes contact with neutral wire. The diagram on Figure 3.8 shows a single line-to-ground fault where F is the fault point with impedances Z_f . Figure 3.9 shows the sequences network diagram. Phase a is assumed to be the faulted phase.

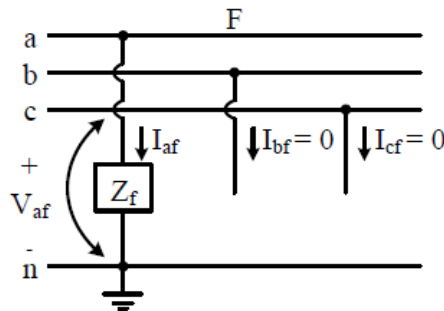

Figure 3.8 Diagram of single line-to-line fault

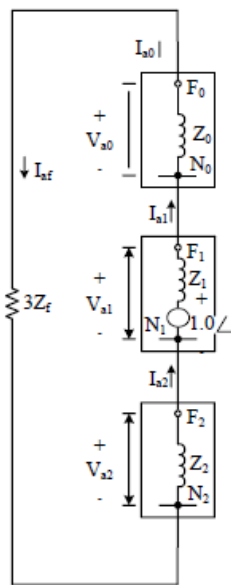

Figure 3.9 Sequence network diagram of single line-to-line fault

Since the zero sequence, positive sequence and negative sequence currents are equals therefore,

$$I_{a0} = I_{a1} = I_{a2} = \frac{1.0 \angle 0^\circ}{Z_0 + Z_1 + Z_2 + 3Z_f} \quad (3.26)$$

Since,

$$\begin{bmatrix} I_{af} \\ I_{bf} \\ I_{cf} \end{bmatrix} = \begin{bmatrix} 1 & 1 & 1 \\ 1 & a^2 & a \\ 1 & a & a^2 \end{bmatrix} \begin{bmatrix} I_{a0} \\ I_{a1} \\ I_{a2} \end{bmatrix} \quad (3.27)$$

Solving Equation the fault current for phase a is

$$I_{af} = I_{a0} + I_{a1} + I_{a2} \quad (3.28)$$

It can also be

$$I_{af} = 3I_{a0} = 3I_{a1} = 3I_{a2} \quad (3.30)$$

From Figure 3.8 it can be observed that,

$$V_{af} = Z_f I_{af} \quad (3.31)$$

The voltage at faulted phase a can be obtained by substituting Equation 3.27 into Equation 3.29. Therefore,

$$V_{af} = 3Z_f I_{af} \quad (3.32)$$

$$V_{af} = V_{a0} + V_{a1} + V_{a2} \quad (3.33)$$

$$V_{a0} + V_{a1} + V_{a2} = 3Z_f I_{af} \quad (3.34)$$

With the results obtained for sequence currents, the sequence voltages can be obtained from,

$$\begin{bmatrix} V_{a0} \\ V_{b1} \\ V_{c2} \end{bmatrix} = \begin{bmatrix} 0 \\ 1.0 \angle 0^\circ \\ 0 \end{bmatrix} \begin{bmatrix} 1 & 1 & 1 \\ 1 & a^2 & a \\ 1 & a & a^2 \end{bmatrix} \begin{bmatrix} I_{a0} \\ I_{a1} \\ I_{a2} \end{bmatrix} \quad (3.35)$$

By solving Equation

$$\begin{aligned} V_{a0} &= -Z_0 I_{a0} \\ V_{a1} &= 1.0 - Z_1 I_{a1} \\ V_{a2} &= -Z_2 I_{a2} \end{aligned} \quad (3.36)$$

If the single line-to-ground fault occurs on phase b or c, the voltages can be found by the relation that exist to the known phase voltage components,

$$\begin{bmatrix} V_{af} \\ V_{bf} \\ V_{cf} \end{bmatrix} = \begin{bmatrix} 1 & 1 & 1 \\ 1 & a^2 & a \\ 1 & a & a^2 \end{bmatrix} \begin{bmatrix} V_{a0} \\ V_{a1} \\ V_{a2} \end{bmatrix} \quad (3.37)$$

and

$$\begin{aligned} V_{bf} &= V_{a0} + a^2 V_{a1} + a V_{a2} \\ V_{cf} &= V_{a0} + a V_{a1} + a^2 V_{a2} \end{aligned} \quad (3.38)$$

3.6.3 Line – To – Line Fault

A line to-line fault may take place either on an overhead and/or underground transmission system and occurs when two conductors are short circuited. The characteristic of line-to-line fault is the fault impedance magnitude could vary over a wide range and it is very hard to predict its upper and lower limits.

When the fault impedance is zero, the highest asymmetry at the line-to-line fault occurs. Figure 3.10 shows the diagram of line-to-line fault.

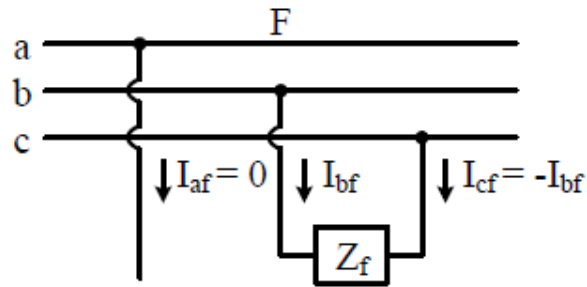

Figure 3.10 Diagram of line-to-line fault

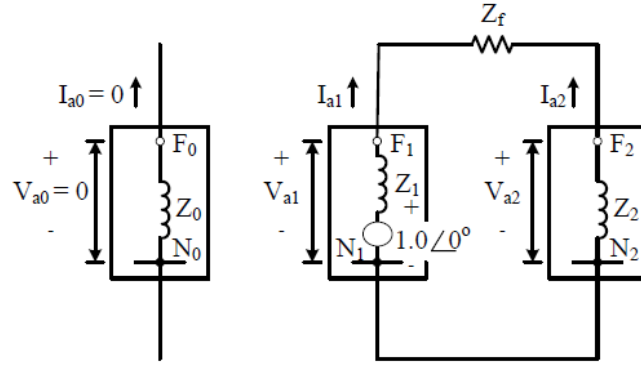

Figure 3.11 Sequence network diagram of line-to-line fault

From Figure 3.11, the equations are

$$\begin{aligned} I_{af} &= 0 \\ I_{bf} &= -I_{cf} \\ V_{bc} &= Z_f I_{bf} \end{aligned} \quad (3.39)$$

The sequence currents can be obtained as

$$\begin{aligned} I_{a0} &= 0 \\ I_{a1} &= -I_{a2} = \frac{1.0 \angle 0^\circ}{Z_1 + Z_2 + Z_f} \end{aligned} \quad (3.40)$$

If $Z_f = 0$

$$I_{a1} = -I_{a2} = \frac{1.0 \angle 0^\circ}{Z_1 + Z_2} \quad (3.41)$$

The fault currents for phase b and c can be obtained by substituting Equations 3.40 into Equation 3.27.

$$I_{bf} = I_{cf} = \sqrt{3} I_{af} \angle 90^\circ \quad (3.42)$$

The sequence voltages can be found by substituting Equation 3.40 into Equation 3.35

$$\begin{aligned} V_{a0} &= 0 \\ V_{a1} &= 1.0 - Z_1 I_{a1} \\ V_{a2} &= -Z_2 I_{a2} = Z_2 I_{a1} \end{aligned} \quad (3.43)$$

Also substituting Equation 3.41 into Equation 3.35

$$\begin{aligned} V_{af} &= V_{a1} + V_{a2} = 1.0 + I_{a1}(Z_2 - Z_1) \\ V_{bf} &= a^2V_{a1} + aV_{a2} = a^2 + I_{a1}(aZ_2 - a^2Z_1) \\ V_{cf} &= a^2V_{a2} + aV_{a1} = a + I_{a1}(a^2Z_2 - aZ_1) \end{aligned} \quad (3.44)$$

The line-to-line voltages for line-to-line fault can be expressed as

$$\begin{aligned} V_{ab} &= V_{af} - V_{bf} \\ V_{bc} &= V_{bf} - V_{cf} \\ V_{ca} &= V_{cf} - V_{af} \end{aligned} \quad (3.45)$$

3.6.4 Double Line – To – Ground Fault

Double line-to-ground fault represents a serious event that causes a significant asymmetry in a three phase symmetrical system and it may spread into a three phase fault when not clear in appropriate time.

When analyzing double line-to-ground fault, the assumption of the impedance Z_f and value of the impedance toward the ground Z_g . Figure 3.12 shows the diagram of double line-to-ground where F is the fault point with impedances Z_f and the impedance from line to ground Z_g . Figure 3.13 shows the sequence network diagram. Phase b and c are assumed to be the faulted phases.

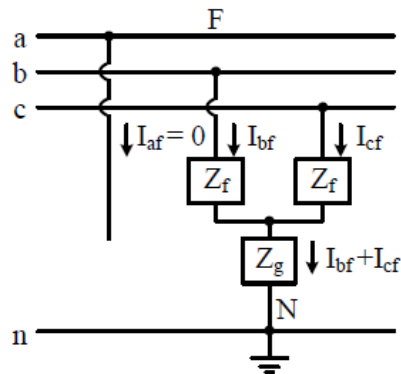

Figure 3.12 Diagram of double line-to-ground fault

REFERENCES

1. Bruce G. Bailey, *Power System Protection – Power Monitoring – Data Logging – Remote Interrogation System*. IEEE. 2005
2. Mesut Baran and Jinsang Kim, *Protection Device Monitoring Using Data from Power Quality Monitoring Devices*, IEEE.2008
3. Dr. Z Schreiner, A.J Middleton and J. Bizjak, *Innovative Technique for Intelligent Power System Mobile Data Management*. pg 459-464
4. Mladen Kezunovic, *Data Integration and Information Exchange for Enhanced Control and Protection of Power System*, Proceedings of the 36th Hawaii International Conference on System Sciences. 2002.
5. Zhang Hai Yang and Li Shan De, *Design of Adaptive Line Protection under Smart Grid*, The International Conference on Advanced Power System Automation and Protection 2011, pg 599-603
6. Takaya Shono, Katsuhiko Sekiguchi, Tatsuji Tanaka and Shigeki Katayama, *A Remote Supervisory System for a Power System Protection and Control Unit Applying Mobile Agent Technology*.pg 148-153, IEEE 2002

8. Janaka Ekanayake, Kithsiri Liyanage, JianzhongWu, Akihiko Yokoyama and Nick Jenkins, *Smart Grid Technology And Applications*
9. Anthony J. Pansini, *Guide to Electrical Power Distribution System. 6th edition*. Lilburn GA. The Fairmont Press. 2005
10. Turan Gonen, *Electric Power Transmission System Engineering, Analysis and Design*, Crc Press Taylor and Francis Group.
11. Paul M. Anderson, *Analysis of Faulted Power Systems*. The Institute of Electrical and Electronics Engineers, Inc. 1995.