

University of Dundee

DOCTOR OF PHILOSOPHY

The role of place in perceived identity continuity

Bowe, Mhairi

Award date:
2012

Awarding institution:
University of Dundee

[Link to publication](#)

General rights

Copyright and moral rights for the publications made accessible in the public portal are retained by the authors and/or other copyright owners and it is a condition of accessing publications that users recognise and abide by the legal requirements associated with these rights.

- Users may download and print one copy of any publication from the public portal for the purpose of private study or research.
- You may not further distribute the material or use it for any profit-making activity or commercial gain
- You may freely distribute the URL identifying the publication in the public portal

Take down policy

If you believe that this document breaches copyright please contact us providing details, and we will remove access to the work immediately and investigate your claim.

Download date: 17. Feb. 2017

DOCTOR OF PHILOSOPHY

The Role of Place in Perceived Identity
Continuity

Mhairi Bowe

2012

University of Dundee

Conditions for Use and Duplication

Copyright of this work belongs to the author unless otherwise identified in the body of the thesis. It is permitted to use and duplicate this work only for personal and non-commercial research, study or criticism/review. You must obtain prior written consent from the author for any other use. Any quotation from this thesis must be acknowledged using the normal academic conventions. It is not permitted to supply the whole or part of this thesis to any other person or to post the same on any website or other online location without the prior written consent of the author. Contact the Discovery team (discovery@dundee.ac.uk) with any queries about the use or acknowledgement of this work.

The Role of Place in Perceived Identity Continuity

Mhairi Bowe

A thesis submitted for the degree of Doctor of Philosophy

University of Dundee

August 2012

TABLE OF CONTENTS

TABLE OF CONTENTS.....	II
LIST OF TABLES.....	V
LIST OF FIGURES.....	VI
LIST OF ILLUSTRATIONS.....	VII
ACKNOWLEDGMENTS.....	VIII
DEDICATION.....	IX
DECLARATIONS.....	X
ABSTRACT.....	1
PROLOGUE.....	3
The Case Study of Franco Magnani.....	3
PART I: THEORETICAL BACKGROUND AND METHODOLOGY.....	7
CHAPTER ONE.....	8
Introduction and Overview of the Thesis.....	8
Introduction.....	8
The Self and Identity Continuity.....	10
Place as a Source of Identity Continuity.....	16
The Future Dimension of Place Identity Continuity.....	22
Outline of the Chapters.....	24
CHAPTER TWO.....	27
Place, Identity, and Continuity: A Multi-disciplinary Literature Review.....	27
Introduction.....	27
The Study of Place.....	29
Conclusions.....	47
CHAPTER THREE.....	49
Place, Identity, and Continuity: A Psychological Literature Review.....	49
Introduction.....	49
Environmental Psychological Theories of Place.....	50
Social Psychological Identity Theories, Place, and Subjective Continuity.....	70
Implications of the Proposed Research.....	90
Conclusions.....	92
CHAPTER FOUR.....	94
Methodological Approaches.....	94
Introduction.....	94

Critical Analysis of Place, Identity, and Continuity Studies.....	97
The Argument for Mixed Methods	109
The Proposed Studies.....	115
PART II: EMPIRICAL STUDIES.....	120
CHAPTER FIVE	121
Study 1: A Qualitative Exploration of Place Identity Continuity	121
Introduction.....	121
Aims of the Study	126
Interview Methods and Design	127
Analysis and Discussion	134
Part 1: Deductive Coding for Place Identity Continuity Dimensions	134
Part 2: Inductive Coding for Place Identity Continuity Themes.....	164
Summary and Conclusions.....	175
CHAPTER SIX.....	181
Study 2: Development of a Place Identity Continuity Measure.....	181
Introduction.....	181
Method	186
Results.....	192
Discussion.....	212
CHAPTER SEVEN	215
Study 3: Place Identity Continuity and Psychological Well-Being	215
Introduction.....	215
Method	217
Results.....	221
Discussion.....	235
Conclusions.....	240
CHAPTER EIGHT	242
Study 4: Social Identity and Place Identity Continuity.....	242
Introduction.....	242
Method	246
Results.....	251
Discussion.....	256
Conclusions.....	264
CHAPTER NINE.....	266
General Discussion	266
Introduction.....	266

Summary of the Findings.....	268
Integration of the Findings.....	273
Unexpected Findings and Limitations	275
Potential Future Research	279
Implications.....	282
Concluding Remarks.....	285
REFERENCES	287
APPENDIX ONE.....	318
Study 1: Interview Schedule	318
APPENDIX TWO.....	321
Study 1: Introducing the Participants.....	321
APPENDIX THREE.....	330
Study 1: Transcription Notation.....	330
APPENDIX FOUR	331
Study 2: Questionnaire.....	331
APPENDIX FIVE.....	346
Study 3: The Satisfaction with Life Scale.....	346
APPENDIX SIX	347
Study 4: The Student Identity Prime Questionnaire	347

LIST OF TABLES

Table 5.1 <i>Key Characteristics and Residential History of Study 1 Participants</i>	132
Table 5.2 <i>A Priori Code Labels and Operational Definitions</i>	135
Table 6.1 <i>Direct Oblimin Rotated Loadings of the Thirty Place Identity Continuity (PIC) Items Following CFA</i>	195
Table 6.2 <i>Direct Oblimin Rotated Loadings of the Thirty Social Place Identity Continuity (SPIC) Items Following CFA</i>	197
Table 6.3 <i>Goodness-of-fit Indices for the Original and Refined Three-factor Models, and the Refined One-factor Model of Place Identity Continuity Items</i>	204
Table 6.4 <i>Goodness-of-fit Indices for the Original and Refined Three-factor Models, and the Refined One-factor Model of Social Place Identity Continuity Items</i>	205
Table 6.5 <i>Intercorrelations and Descriptive Statistics for Study 2 Variables</i>	208
Table 7.1 <i>Goodness-of-fit Indices for the Three-factor PIC Model and Three-factor SPIC Model</i>	223
Table 7.2 <i>Intercorrelations and Descriptive Statistics for Study 3 Variables</i>	228
Table 8.1 <i>Means and Standard Deviations for all Variables According to Condition</i>	252

LIST OF FIGURES

Figure 5.1 <i>Categories and Sub-Categories of Place Identity Continuity Themes</i>	164
Figure 6.1 <i>Results of CFA for the Refined 20-item Three-factor PIC Model</i>	202
Figure 6.2 <i>Results of CFA for the Alternative 20-item One-factor PIC Model</i>	203
Figure 6.3 <i>Results of CFA for the Refined 20-item Three-factor SPIC Model</i>	206
Figure 6.4 <i>Results of CFA for the Alternative 20-item One-factor SPIC Model</i>	207
Figure 7.1 <i>Results of CFA for the Cross-validated 20-item Three-factor PIC Model</i>	224
Figure 7.2 <i>Results of CFA for the Cross-validated 20-item Three-factor SPIC Model</i>	225
Figure 7.3 <i>Mediation Models for the Effects of Place Identity Continuity Dimensions on Satisfaction with Life Mediated by Place Identity</i>	232
Figure 7.4 <i>Mediation Models for the Effects of Social Place Identity Continuity Dimensions on Satisfaction with Life Mediated by Place Identity</i>	234
Figure 8.1 <i>Moderated Regression of Identity Salience Condition and Total Years Residency on Place Referent Continuity</i>	254
Figure 8.2 <i>Moderated Regression of Identity Salience Condition and Place Identity on Place Congruent Continuity</i>	255

LIST OF ILLUSTRATIONS

Illustration 1. " <i>Pontito Panorama</i> " by Franco Magnani.....	3
Illustration 2. " <i>Finestra Spazzile</i> " by Franco Magnani.....	6

Both illustrations reproduced with permission from the artist.

ACKNOWLEDGMENTS

Over the course of my doctoral studies I have become indebted to many people, each of whom I wish to wholeheartedly thank. Though at times studying for a PhD is a lonely endeavour, I have been lucky enough to share it with each of the following people in one way or another. For this I am truly grateful.

Firstly, it has been my absolute pleasure to work with my supervisor, Professor Fabio Sani, whose support and kindness have comforted me throughout many crises. I am always thankful for the opportunities that he has given me, bestowed with both faith and confidence even when I lacked it myself. Dr Nick Hopkins also deserves special thanks, not only for his patience as I wrangled with epistemological dilemmas, but also for his warmth, hospitality, and humour that kept my feet firmly on the ground. I would also like to give Dr Suzanne Zeedyk thanks for her encouragement, which gave me the confidence to embark on my doctoral studies.

I would like to give my thanks to all the members of academic, office, and technical staff, each of whom added to my experience at Dundee University. The School of Psychology always felt like a home to me thanks to you all. Thanks go out to John Morris, Liz Evans, Linda Fullerton, Heather Henderson, Astrid Schloerscheidt, Victoria Bourne, Douglas Potter, Mark Bennett, Emese Nagy, Alissa Melinger, and Trevor Harley for the support they have each provided. Special thanks go to Sammyh Khan and Juliet Wakefield for their patient statistical advice. I also wish to thank the postgraduate community at Dundee, past and present. Such a vibrant collection of individuals made the experience fun and intellectually challenging, and it has been a pleasure to share the years with them all. Specific thanks go to my wonderful fellow student, Mandy Yilmaz. I cannot describe how invaluable your support has been throughout the course of my research and the write-up of this thesis. I am eternally grateful for your friendship and am proud to call you a colleague. I am also indebted to the fabulous Gillian Shorter for the week she spent proof-reading, dog-walking, and looking after my children, to Alex Meredith for his formatting genius, to Claire Pooley for her friendship and endless proof-reading, and to Ali Farquharson for putting a roof over my head during the trips to Scotland.

Finally, the largest debt of gratitude is owed to my family and friends for having endured listening to me talk about this thesis endlessly. I wish to thank Gordon Lumsden for his continuous love, kindness, and understanding, as well as his generous provision of meals and childcare in times of need. Lastly, I would like to thank my amazing children Ailidh and Ciaran for patiently waiting on me to finish this thesis and for never moaning about me sitting at the computer all the time. Both have been outstanding.

This work was supported by the Economic and Social Research Council and only possible due to the time donated by each of my participants.

DEDICATION

This thesis is dedicated to my mother, Janice MacGillivray, who made every place I lived a warm and loving home, and showed me what it is to be courageous and hard-working whilst still allowing your imagination the freedom to dream.

DECLARATIONS

Statement: I declare that I, the candidate, am the author of this thesis. Unless otherwise stated, all references cited have been consulted by the candidate. The work of which this thesis is a record has been done by the candidate, and it has not been previously accepted for a higher degree.

Signature: _____
(Candidate)

A handwritten signature in cursive script, appearing to read "M. Bowe", is written above a horizontal line.

ABSTRACT

The core principle underlying this research program is that places can contribute to identity, and that like other elements of identity they may be subject to the same psychological processes. One way in which personal and social identity have been characterised is by their provision of a psychologically significant sense of identity continuity. The overarching question addressed throughout each chapter of this thesis is whether places are significant aspects of identity because they too provide a sense of temporal endurance: *place identity continuity* (PIC). Four empirical studies aimed to address this question using insights from social psychological theory. They also aimed to reveal the structure of place identity continuity, its psychological significance, and whether variation in its expression could be accounted for using social context.

Following an introduction to the core themes of the thesis in Chapter One, Chapters Two and Three provide reviews of the literature connecting place, identity, and continuity: the first from disciplines outside psychology and the second from psychology itself. Chapter Four describes the research methods to be used, and ends Part I of the thesis. Part II presents the empirical studies. Chapter Five reports the results from Study 1, an interview study conducted with residents of Tayside, exploring their place experiences and perceptions of identity continuity in relation to places. It reveals that place relationships can be characterised by connections with past and future selves, and a sense of fit between place and self, but that they can also vary according to strength of place identification and social context. Chapter Six reports the results of Study 2, a large student survey study leading to the development of a three-dimensional scale to measure PIC, and confirmation that PIC is connected with place attachment and place identity. Chapter Seven reports the results of Study 3, a cross-validation of the PIC measure and examination of the varying connections

between PIC dimensions and psychological well-being in a large general public survey study. Finally, Chapter Eight reports the results of Study 4, an experiment showing that PIC can vary according to self-categorisation such that those categorising themselves as a family member will generally rate PIC higher than those primed with a student identity.

Chapter Nine draws the results of each study together to conclude that PIC is a significant aspect of place identity, and that it is characterised by connections with past place identity, present place and self congruency, and future place identity, thus extending the existing place identity literature. It is also concluded that the use of social psychological approaches enriches previously static and deterministic understandings of place identity, and provides an opportunity to integrate social and environmental psychology. Limitations, future studies, and theoretical and practical implications are then provided before concluding remarks are offered.

PROLOGUE

The Case Study of Franco Magnani



"Pontito Panorama"

© Franco Magnani

By virtue of our very existence, we are all somehow connected to a place. These connections may be weak or strong, coincidental, or fundamental, but few cases have been displayed with more fervour than that of the Tuscan painter, Franco Magnani. Magnani is famed for his paintings, their astounding accuracy revealing the unnerving gift of memory possessed by the artist. However, it is the *subject* of his paintings that is of particular relevance to the present thesis: his Italian hometown of Pontito. It is, moreover, the reasons for his paintings and the functions they serve that are significant, first and foremost, to the story this thesis will tell. To explain, it is necessary to introduce the reader to the case of Franco Magnani, first elucidated by the neurologist and writer, Professor Oliver Sacks in his collection of essays: *An Anthropologist on Mars* (Sacks, 1995).

Born in 1934, Franco Magnani grew up in the village of Pontito in the hills of Tuscany. A small, historic, self-contained village, its inhabitants led a self-sufficient lifestyle steeped in traditional values and customs until the 1940s when the coming of war and Nazi occupation changed the landscape of Pontito irreversibly. Many inhabitants were forced to

leave to seek work, and Magnani himself became one of them in 1946, leaving to learn a trade. During this time he missed Pontito terribly and spent much of his time mentally replaying the autobiographical scenes of his childhood and telling stories of Pontito. Following a brief return in the 1950s when he witnessed the decline of Pontito, Magnani – not yet the artist he would become – left Pontito for work in Europe, and later America. For several years, he lived with some content until in the mid-1960s when a strange affliction began to trigger overwhelmingly vivid dreams and visions of the Pontito of his past. This period marked the beginning of a series of events where Magnani seemingly involved himself in elaborate attempts to *recreate* Pontito. The nature of the illness that took hold of him at this time remains debated, but it has been linked to the rigours of the work he was forced to undertake and the issues he was purported to have with immigration services. The combination of these circumstances resulted in a period of prescribed bed-rest and eventually some time in a sanatorium.

Sacks offers an alternative explanation, however, suggesting that the impetus for this series of events may have been Magnani's final decision to abandon Pontito for permanent residency in San Francisco; this conclusion being influenced by his observations that it was during this time he became visibly obsessed with his hometown. The dreams of his childhood Pontito that he experienced during this time were described by Magnani as so real that he could step into them. On waking, he reported feeling overcome with nostalgia and overwhelmingly compelled to reproduce the Pontito that appeared before him. Photographic comparisons with the resulting paintings later revealed their stunning precision, although done from Magnani's child's-eye-view. Sacks describes that Magnani felt the images "promised him a repossession of Pontito" (1995, p. 151) and that his obsessive reproductions of Pontito were not the result of illness, but were the result of a spiritual gift or 'calling'; a gift which necessitated his compliance in preserving Pontito for eternity. A task he believed

was so important because by sharing his paintings with the world he reasoned that “it won’t die, although it is dying [...] my paintings will at least keep its memory alive.” (p. 168).

Franco Magnani remains a successful and much revered painter who is still engaged in the preservation and recreation of Pontito. The effects of his ‘illness’ and his chronic exercise in nostalgia on his well-being are important, but it is the reasons behind this exercise that are of primary concern for this thesis. Sacks suggests Magnani’s painting results from three significant features of his identity. First, the detailed, multi-dimensional visions of Pontito that he experienced following his illness, potentially due to a form of temporal lobe epilepsy. Second, his outstanding memory abilities, which were apparent from childhood. Third, and perhaps most importantly, Magnani’s specific psychological experiences: the loss of his father; a strong attachment to his mother to whom he made a promise to ‘recreate’ Pontito; his nostalgic love and admiration of Pontito as a ‘citadel against the flux of change and time’; his loss of connection with Pontito; and finally his witnessing of its change and death – a loss of identity as the Pontito he recognised and loved. It seems perhaps that the first two features have provided Magnani with the skills that underwrite his ‘memory art’ and thus provide the means to satisfy the psychological desires resulting from his experiences.

The experience of loss and discontinuity is a key issue in this thesis. Sacks (1995) suggests that the propensity to recollect is brought about by separation or change, a taking away from the significant features of one’s life: the people, the events, and even the places. Indeed in this account it is clear to see that the place, Pontito, is infinitely connected to the life of the man. Not just because his paintings depict scenes from his own autobiography, but also because he connects the task of its preservation to his own existence at a metaphorical and spiritual level. Indeed anticipating his return to Pontito and the prospect of finding it different to the way he has so perfectly encoded it, he suspects that he himself will die – his life and the place are so inextricably entwined. Sacks links this separation from place to

notions of continuity and change. He suggests, “It is thus the great discontinuities in life that we seek to reconcile, or integrate by recollection, and beyond this, by myth and art” (p.160). Further, he insists, “Discontinuity and nostalgia are most profound if, in growing up, we leave or lose the place where we were born or spent our childhood, if we become expatriates or exiles, if the place or the life we were brought up in is changed beyond recognition or destroyed. All of us finally are exiles from the past” (p.160). For Magnani, life has afforded a way to overcome this discontinuity with his treasured place by repeated reproduction of its scenes, but the motives behind this task may be familiar to many, though perhaps realised by more mundane means. This thesis seeks to discover whether in fact we all, to some degree, seek to preserve the places from our past, to conquer these discontinuities by possessing and preserving these places for the future and linking our lives to them, as Magnani has with Pontito. Moreover, it seeks to explore the conditions under which this preservation and connection is not sought. This tripartite model of identity, place, and continuity provides the framework upon which these tasks will be endeavoured.



"Finestra Spazzile"

© Franco Magnani

**PART I: THEORETICAL BACKGROUND AND
METHODOLOGY**

CHAPTER ONE

Introduction and Overview of the Thesis

“We do not grasp space only by our senses...we live in it, we project our personality into it, we are tied to it by emotional bonds; space is not just perceived...it is lived”.

Georges Matoré (1962)

Introduction

The idea that places are simply the backdrop to our experiences has long been rejected by many disciplines of human enquiry. These ideas circulate widely in the work of human geographers and environmental psychologists, but have been approached from researchers located anywhere between architecture and leisure studies, where place has been succinctly described as, “a dynamic context of social interaction and memory” (Stokowski, 2002, p.268). The formulation of the environment as a series of meaningful human ‘places’ as opposed to simple physical ‘spaces’ by geographers such as Yi-Fu Tuan and Edward Relph in the humanistic geography movement of the 1970s, helped promote this subjective approach to the study of the relationships between people and their geographical surroundings. This acknowledgement of place as a human concept also finds real-world support in popular practices such as heritage protection and the search for ‘roots’, along with popular notions of ancestral and cultural homelands; both of which demonstrate not only the significance of place for everyday life but also its role as a symbolic signifier of human history and hence identity.

The power of place as a construct that extends beyond the simple physicality of the environment is therefore clearly apparent in many contemporary human phenomena. Perhaps none are as dramatic as the struggles that ensue between warring factions of residents who claim ownership of a contested homeland: a situation that is all too familiar in current socio-political climates across the globe. Place, therefore, appears to have a distinctly *social* element. This element has not gone unnoticed by social psychologists such as Dixon and Durrheim (2004), who describe place as a changing interactive environment which is “both socially constituted and constitutive of the social” (p. 27). Yet despite its importance, place is an elusive concept in psychological research and resultantly it has, for the most part, remained a neglected area of social psychological enquiry.

Instead, the significance of place has been traditionally been discussed from phenomenological, sociological, and geographical perspectives. This situation is problematic for a discipline that concerns itself with matters of identity precisely because of this definition of place as a construct which reaches beyond location into the realm of human experience and emotion. Instead, the concept must be tackled using a psychological perspective, such that its role as a potentially crucial constituent in an individual’s life story, identity, and well-being may be appreciated, understood and where necessary, protected. It is towards this very task that this thesis will aim. In order to satisfy this aim, it will be proposed that the concept of continuity, which is pervasive in each of these multi-disciplinary discussions of people and place relationships but never fully elucidated, should be examined with a social psychological approach as a potential means of understanding the links between place and identity.

The Self and Identity Continuity

Philosophical Conceptualisations

The concept of identity is a principal theme of this thesis. Identity is a familiar and well-researched concept that spans numerous areas of investigation in psychology. Of course, it is also a fundamentally *human* issue as notions of self and identity are central features of existence. Most people are familiar with some kind of introspection that takes the form of “Who am I?”, “What am I?” or “What is my purpose?” questioning. Given the fundamentality of these questions to the human state, they have shaped the foundations of philosophical enquiry for centuries where they have been formulated as a series of ‘problems’. One of the foremost of these questions is labelled the ‘Problem of Persistence’ (Olson, 2007). This philosophical problem can be traced as far back as Plato’s *Phaedo* and is so inherently linked to philosophical conceptions of personal identity that it follows seamlessly from any enquiry of the self, and is included in almost any undergraduate dictionary or encyclopaedia of philosophy (e.g., Blackburn, 1996). This issue has been addressed using various headings: ‘unity’, ‘sameness’, ‘diachronic identity’, and so on, but essentially the issue relates to how we can be sure that the self remains the same across time. Moreover, it is concerned with reconciling intuitive perceptions of this ‘sameness’ of self from moment to moment with an acknowledgement of the persistent changes in human identity that occur across the lifespan (More, 1995).

By far the most common approach to the solution of this problem has been psychological in essence, and follows the reasoning of John Locke (1690/1980) who suggested the enduring physical body alone is not enough to guarantee sameness of self. Instead continuous streams of consciousness were set forth as the key to understanding personal identity and unlocking the solution to the persistence problem. The psychologically-

based approaches that followed centre on evidence from various psychological phenomena such as traits, mentalities, memories, preferences, and so on, but all are centralised on one theme: the achievement of a *sense* of self-continuity (Sani, 2008b). Parfit (1987) has suggested a division of these solutions into two main categories: 1) ego theories, and 2) bundle theories. The former relying on some unchanging essence or inner self (e.g., Descartes, 1641/1993; Baars 1997) and the latter referring to the contiguity of an on-going series of perceptions and sensations experienced by the individual across time (e.g., Hume 1739/2000). The issue of identity continuity continues to receive attention from various accounts that situate themselves between these two theoretical positions. For example, Daniel Dennett (1991) has offered up a theory describing subjective continuity as afforded via collections of personal narratives where the self represents the ‘Center of Narrative Gravity’. Proponents of this type of model typically suggest that despite the multiplicity of identity, the life narrative affords an essential source of continuity (Frie, 2011). More recently, neuroscientific studies have added a neurophenomenological dimension by offering biological location-based solutions to the issue of continuing conscious experiences of self (e.g., Lutz & Thompson, 2003). What is clear is that questions of self continuity form an area of enquiry that continues to stimulate and puzzle; perhaps because it is viewed as so fundamental to human existence. As Kierkegaard (1843/2000) concluded: “A human being’s eternal dignity lies precisely in this, that he can gain a history. The divine in him lies in this, that he can give this history continuity” (p.80).

The View from Psychology

Whilst the self is a conspicuous topic within philosophical traditions, it is by far one of the most important topics in the discipline of psychology. This is partly because, although sometimes tacitly, the self is a primary determinant of behaviour (Baumeister, 2000;

Oyserman, 2004), but also because psychologists recognise as well as philosophers that the self is at the forefront of human awareness, and hence experience. As Gordon Allport stated, “The existence of one’s own self is the fact of which every mortal person – every psychologist included – is perfectly convinced” (1943, p. 451). The primacy of the self has meant that psychologists have also acknowledged the fundamentality of the introspective “Who am I?” questions in their theorising. They have offered up the self-concept and the idea of personal identity as the answers to these questions (Neisser, 1993), and generally agree they form a crucial element of human existence (Lewis, 1990). Social psychologists have paid particular attention to the topic of selfhood and its behavioural, emotional, and motivational consequences (for reviews see Banaji and Prentice, 1994, and Baumeister, 1998). Although the self-concept is generally understood as a unifying multi-faceted stock of self-knowledge, it has been claimed the nature of selfhood is hard to pin down theoretically, therefore there exist various alternative perspectives on the precise nature of the phenomenon (Baumeister, 2000). What is clear is that the concept of identity is bound up with notions of the self, and as such identity also has implications for perception, emotion, and behaviour.

Early identity theories described distinct aspects of self and included a clear role for others in the self. For example, William James (1890/1981) famously drew a distinction between the ego or ‘I’, which can be thought of as the ‘knower’, and the ‘Me’ reflecting the ‘known’. Subsequently, symbolic interactionist approaches to identity highlighted the individual’s relationships with others, including a version of self as defined both by one’s own perceptions and by interpretations of others’ perceptions (e.g., Mead, 1934). These theories gave way to social cognitive versions of the self during the 1970s era of behaviourism (Kihlstrom & Canter, 1984). These theories focussed on a definition of the self-concept as a knowledge structure stored in memory in the form of a series of self-schema, each with varying levels of conscious accessibility (Markus, 1977; Markus & Kunda 1986;

Markus & Wurf, 1987). This personality account of the self presupposed a largely stable and fixed self, and because of this the account has subsequently been criticised for failing to take into account context and the role of others fully, rendering it unable to account for processes of self and contextual change (Onorato & Turner, 2001). In their place, accounts of the self-concept based upon processes of self-categorisation have been proposed by researchers in the social identity tradition (Turner & Onorato, 1999; Turner, Reynolds, Haslam, & Veenstra, 2004).

Further alternative perspectives on the creation and maintenance of self have also been offered, including those that centre on self-verification and the search for self-consistency (Swann, 1987). However, perhaps the most useful theoretical starting point for the study of place and identity is Breakwell's (1986, 1992, 1994) Identity Process Theory, which considers the self as a product of multiple dimensions of identity. Both personal and social accounts of identity will be revisited later in this thesis, but for present purposes it is important to note that each of these models of self has consequences for our understanding of self continuity, because each include in their procedural accounts notions of identity stability, and change, and therefore also continuity.

In contrast to self theories, which involve self continuity as a by-product or consequence of their theoretical conceptualisations, many have made issues of self continuity absolutely explicit in their enquiries. Taking their lead from philosophical study of the topic, psychologists have long documented that a sense of self continuity is a fundamental feature of the self and that its achievement is a core developmental task (Erikson, 1959; James, 1890/1981). Neisser (1988) recognised the significance of subjective self continuity by inclusion of the 'extended self' in his five-part model of self-knowledge. He related this type of self-knowledge to the extension of self across time, from past to future, and considered it a

product of assimilation between present self-knowledge, memory of past selves, and possible future selves.

Perceptions of self-continuity also play a pivotal role in theories describing the construction of narrative identity, and the connections between autobiographical memory and the creation of life stories (Bluck & Habermas, 2001; Conway, Singer, & Tagini, 2004; McAdams, 2001). It has also been implicated in theories espousing the importance of ‘possible selves’ for motivation and action (e.g., Markus & Nurius, 1986). However, it is worth pointing out that in spite of its role as a key characteristic of self in early self theories, the issue of self continuity did not receive much attention until around the last decade, which Sani (2008b) suggests might be attributable to the behaviourist movement, which disregarded internal states in favour of measureable behaviours.

The perception and experience of self continuity has been associated with a whole host of positive psychological outcomes. Perhaps one of the most compelling of these findings is the relationship between perceived continuity and mental health. Perceived personal self continuity has been linked with psychological well-being, positive affect, and a sense of authenticity (Diehl, Jacobs, & Hastings, 2006; Troll & Skaff, 1997). Consistency and stability of self have also been repeatedly associated with higher self-esteem, increased self-knowledge, low neuroticism, and lower depression scores (Campbell, 1990; Campbell & Lavalley, 1993; Campbell et al., 1996). Perceived continuity provides a source of self-knowledge that has been documented as pivotal across the life-span, in the development of self, adolescent identity processes, and successful aging (Bird & Reese, 2008; Brandtstader & Greve, 1994; Fivush, Habermas, Waters, & Zaman 2011; Nelson, 2008). Moreover, a lack of continuity has been linked with numerous maladies and disorders of the self (Scharfetter, 2003; Sims, 2003). These include conditions such as Parkinson’s disease (Haberman, 1999); dementia (Haslam, Jetten, Haslam, Pugliese, & Tonks, 2011); Schizophrenia (D’Argembeau,

Raffard, & Van der Linden, 2008), and various conditions and injuries that result in dissociative experiences (Sacks, 1985). An inability to maintain a sense of continuity can also lead to potentially grave psychological outcomes, such as increased risk of suicide, especially in the young members of marginalised cultural groups (Chandler, Lalonde, Sokol, & Hallett, 2003; Chandler & Proulx, 2008).

Temporality is also a defining feature of human collectives and features in early social identity conceptualisations, although this has not always been evident in subsequent empirical paradigms (Condor, 1996). Nevertheless, social psychologists have recently recognised that a sense of identity continuity is also an important feature in social groups. Sani and colleagues (Sani, Bowe, Herrera, Manna, Cossa, Miao, & Zhou, 2007), for example, introduced the construct ‘perceived collective continuity’ to describe ingroup perceptions of national and regional groups as both historically and culturally enduring. Across several studies they demonstrated the importance of these perceptions, finding them to be related to a multitude of positive group cognitions such as collective self-esteem, common fate, and entitativity, and later as a key component of social well-being (Sani, Bowe, & Herrera, 2008b).

Perceived collective continuity has also been found to be important in other group identities. It is, for example, associated with better functioning in family groups (Bowe, 2008; Herrera, Sani, & Bowe, 2011). It has been identified as a key component of organisational identity, especially in contexts of merger and take-over (Jetten & Hutchinson, 2011; van Knippenberg, van Knippenberg, & Bobbio, 2008), and its loss has been implicated in various groups undergoing schismatic processes (Sani, 2008a). In fact, the scope of the construct goes so far, it has even been named as a key factor in protecting against existential anxiety (Landau, Greenberg, & Solomon, 2008; Sani, Herrera, & Bowe, 2009), and in politically strategic constructions of group identity (Reicher, 2008).

A crucial implication of the research outlined above is that despite the complexities of life and the inevitable changes undergone, some sense of continuity of self across time may be psychologically valuable, if not vital. This continuity can be achieved through aspects of personal identity, memory, and narrative, as well as via perceptions of collective continuity. It is essential to note, however, that this sense of continuity might be afforded by other elements of the self. It is the proposal of this thesis that identifications with place might be one of these continuity providing mechanisms.

Place as a Source of Identity Continuity

Whilst within social psychology places have traditionally only been linked symbolically to identity via social identifications such as national groups (Speller, Lyons, & Twigger-Ross, 2002), place does appear in some of the earliest literatures on the self. Revisiting the work of William James, there are clear references to the issue of self continuity, but more importantly the potential role of place in identity was recognised in relation to both James' elements of self. Within his theorising on the 'Me', or knower, James spoke of how the boundary between self and other can become blurred so that external items such as possessions can feel like part of the self. He even goes as far as to state that, "In its widest possible sense... a man's self is the sum total of all that he can call his, not only his body and his psychic powers, but his clothes and *his house*, his wife and his children, his ancestors and friends, his reputation and works" (1890/1950, p.292; italics added). These aspects of the material self are viewed as fundamentally connected to the individual in such a way that their loss results in a sense of 'shrinkage', or forfeiture of self. This emotional investment in places is eloquently elaborated on in James' discussions on the home: "Its scenes are part of our life; its aspects awaken the tenderest feelings of affection... We have a

blind impulse to [...] find for ourselves a house of our own which we may live in and improve” (p. 292).

In contrast to these explicit connections, the link between the “I”, or knower, and place is less clear. However, this ego-related dimension of self has been likened by some contemporary theorists to the part of the self associated with the construction of the life story or ‘narrative identity’ (Prentice, 2000). This narrative identity has been found to be linked to place by numerous researchers who stress the importance of places in varying degrees. Essentially, they convey the message that places can be used by individuals to construct and document their life stories, often via autobiographical memory, because they can act as cues, or memory aids, providing a sense of ‘environmental constancy’ (Bluck & Alea, 2008; Taylor, 2010). Following this reasoning, authors have suggested that if the environment experienced on an everyday basis can provide easily accessible physical cues to memories of personal history, then less memory work has to be done to achieve subjective self continuity (Nelson, 2003). In contrast, if the individual has moved from environment to environment throughout their lives they will usually resort to more effortful recall of memories in order to create a continuous life narrative, especially in old age (Conway & Hague, 1999). These theories have subsequently been put to good use in various areas of applied psychology, for example, pictures of old family houses have been used to help adopted children maintain a sense of continuity with their past (Brookfield, Brown, & Reavey, 2008), and relocating elderly adults are actively encouraged to recreate ‘home-like’ place attachments on entering residential care environments to reduce relocation trauma and challenges to feelings of familiarity and person-environment fit (Oswald & Rowles, 2006; Rowles & Watkins, 2003).

In James’ (1890/1950) theorising, place is a concept given as much of a role in defining the self as other more obvious aspects of identity, such as family and friends. This equating of place with other aspects of James’ self has been noted by environmental

psychologists (e.g., Twigger-Ross, Bonaiuto, & Breakwell, 2003), but as yet recognition of the equity between these dimensions of self has not featured explicitly in leading social psychological theories such as Social Identity Theory (Tajfel & Turner, 1981). Thus far, only Breakwell's (1986, 1992, 1994) Identity Process Theory has theorised explicitly about these multiple dimensions of self, and their role in the creation and maintenance of identity (Breakwell, 1996). The integration of these major social psychological approaches is a primary motivation in this construction of this thesis, and will be discussed in full in Chapter Two and Three. What is more important is the dual recognition of multiple identity elements (including places) and the role of continuity in the identity process account. Continuity is argued to be a key motive or desire that guides the construction and maintenance of identity, referred to as the 'continuity principle'. This means continuity should be considered a key component in explanations of identity processes illustrating the importance of perceptions of continuity in defining relationships with elements of identity, such as places.

Whilst Breakwell's (1986, 1992, 1994) model provides the most clearly acknowledged social psychological account of place as an identity component, it is worth noting one other less-known theory within the discipline that has incorporated place into its multi-dimensional account of the self. Burris and Rempel (2004) have introduced 'Amoebic Self Theory' to promote a version of the self which is concurrent with James' ideas. In their account, the self can be thought of as including a series of dimensions, one of which is the 'spatial symbolic self'. This dimension is concurrent with James' material self, and is said to include identity markers such as cherished possessions, interpersonal relationships, and importantly the places we recognise as our own. This approach also makes links between place, identity, and continuity by arguing that through the maintenance of these symbolic structures the individual is afforded a sense of continuity (Burris & Rempel, 2008).

Both of these theoretical approaches have forged some initial associations between the three constructs of place, identity, and continuity, but these links remain largely unexplored by the discipline of social psychology itself. It does, however, follow from these accounts that significant places like one's home might be identity elements that could contribute to subjective self continuity. Indeed sociologists have agreed that the home in particular is a source of psychological stability and ontological security (Dupuis & Thorns, 1998; Padgett, 2007). If this is the case then it is possible that other places representative of the self will satisfy this self continuity need. In recognition of this possibility, the links between various place identifications and perceived continuity will be addressed throughout this thesis.

In order to gain a full appreciation of the human significance of place and its relationship with identity continuity it is essential to look at the concept of place identity from its earliest conceptions and from disciplines outside of social psychology, as these form the primary sources of theorising on place and identity. These theories will only be touched on conceptually here, as full discussion of their methods and conclusions will be provided later in Chapter Two.

As mentioned in the introduction, the discipline of human geography was pivotal in establishing the significance of places to human life, showing them to be symbolically meaningful and extended beyond the physical environment. These accounts exploring the *experience* of place also included some clear acknowledgement of the temporal dimensions of people and place relationships. Lowenthal (1975) for example, discussed the desire to preserve historical sites to maintain a psychologically comforting sense of temporal continuity with previous generations. Edward Relph (1976) provided a similarly explicit exposition of place and continuity in his book *Place and Placelessness*. He argued not only that places themselves embody characteristics of persistence, but that relationships with them

can symbolise a sense of endurance that both leads to our attachment with them deepening and becoming imbued with a sense of continuity. His in-depth analysis of place and its phenomenological dimensions paved the way for further key theoretical approaches that sought to highlight the emotional dimensions of place, including place attachment, sense of place, place identity, and several more (Seamon & Sowers, 2008). Each of them highlighted two key points: that places have a psychological impact on people, both socially and individually, and that relationships between people and places, particularly those characterised by stability and endurance, can be vital for psychological health and well-being (Rowles, 1983).

The work of human geographers not only allowed the relationships between people and places to take centre stage within their own discipline, it also allowed several other disciplines to make the connection between places, people, and continuity. As stated earlier, these approaches are multiple and variable, but outside of psychology it is anthropology and sociology that have made the issue of place continuity most clear. Anthropological accounts, for example, have highlighted the role places have in human history and matters of temporality, observing that significant places often pass symbolically through generations of families and communities (Ambrecht, 2008). Sociologists have also described the role of places as symbolic constructions, essential for human narratives, and representing collective memory (Milligan, 2007). This has led some to emphasise their part in the creation of a 'temporal identity' (Easthope, 2009). Moreover, just as geographers have emphasised the emotional significance of places, these disciplines have also noted the psychological impact of places and the continuity they provide. Milligan (2003) for example, directly addressed this temporal dimension by looking at the negative outcomes of forced relocations and the discontinuity these disruptions bring about, again demonstrating the role of places as providers of continuity.

It is clear then that several theoretical domains have identified a psychological connection between people and places, and that these connections involve an inherently temporal dimension. Whilst it has been noted that social psychologists have on the whole failed to address this tripartite relationship between place, identity, and continuity, environmental psychologists have in fact introduced the term ‘place-identity’ to specifically refer to the part of identity that is developed via socialisation with significant places (Proshanky, 1978). Like Identity Process Theory (Breakwell, 1986, 1992, 1996), Proshanky’s ‘Place-Identity Theory’ has argued that places and other aspects of the self (e.g., social groups) are equivalent sub-structures in identity, and as such should be subject to the same procedural accounts and be deserving of equal attention in psychological research (Proshansky, Fabian, & Kaminoff, 1983). Indeed, Krupat (1983) has claimed simply that place relationships are integrated into the self-concept in such a way that they become a “part of the person” (p. 343).

Importantly, the key role of continuity in the relationship between place and identity featured in some of the early formulations of place-identity as a challenge to static conceptions of identity – a challenge social psychologists have also deemed as crucial in their own theorising on social identity (see Condor, 1996). They therefore sought to examine the effects of change of environmental settings on identity by looking at cases of residential relocation, and concluded that one of the overarching functions of place identity is the development of self continuity and its relationship to self integration. More precisely, the authors stated that, “perceived stability of place and space [...] validate the individual’s belief in his or her own continuity over time” (Proshansky et al., 1983, p.66). This work went on to inspire numerous research programmes within environmental psychology identifying perceived continuity as an important aspect of place identity (Fullilove, 1996; Korpela, 1989; Lalli, 1992). However, because little specific empirical attention was given to Proshansky’s

statements, and there lacked any guidelines upon which one might expect these processes to occur, there has been little subsequent research able to reveal the processes by which places might be related to perceived identity continuity (Twigger-Ross, Bonaiuto, & Breakwell, 2003).

The Future Dimension of Place Identity Continuity

Although there remains little empirical exploration of the relationship between places and identity continuity, there has been one specific collection of qualitative studies which have drawn on place identity literature to explore participants' relationship with their residential locations. These studies conducted by Twigger-Ross and Uzzell (1996); Speller (2000); Speller, Lyons, and Twigger-Ross (2002); and Speller and Twigger-Ross (2009) all utilise the identity process model as their theoretical framework and therefore include a direct reference to identity continuity in their analysis. Notwithstanding any potential methodological critiques, I will argue that this research is limited in one specific way: it involves a conception of continuity that relates only to the individual or group past and the congruency of the place with present identity needs. This leads to an analysis of place identity which includes no reference to the future. This is problematic for two main reasons: 1) it is incongruent with psychological notions of self continuity at both personal and social levels; 2) it is not in line with theorising on place and continuity emanating from the multiple disciplines outside psychology reviewed above.

Indeed it is clear that to form any type of psychological representation of the self, it is necessary to include within that representation a conceptual link between not only the past and present, but the future too. Discussing selfhood, the neuroscientist Edelman states, "The concept of a personal self necessarily assumes the ability to model the future as well as the past into some correlated scene" (Edelman, 1992, p. 122). Psychologists have agreed with

the importance of this mental time travel, drawing on the notion of ‘autonoetic consciousness’ – the ability to be conscious of the self in time – they have argued that conceiving of the self during past events is closely linked to the ability to project oneself in to the future (Quoidbach, Hansenne, & Mottet, 2008). This inherent temporal connection is implicit in all the psychological accounts of self that have been provided, but has been explicitly stated both by theorists looking at personal identity and the mental health outcomes associated with a projected future (e.g., Edelman, 1992), and those concerned with collective notions of identity (e.g., Chandler & Proulx, 2008; Sani et al., 2007). Indeed, social psychologists have identified the loss of a sense of future continuity, realised through group identifications, as a considerable source of collective angst (Wohl, Squires, & Caouette, 2012) and have shown that these sorts of identity components can provide a sense of temporal extension, security, and continuity of self that protects from anxiety and existential concerns regarding mortality and the future (Sani, Herrera, & Bowe, 2009; Solomon, Greenberg, & Pyszczynski, 1991).

Moreover, human geographers such as Relph have also suggested that places represent, “the present expressions of past experiences, and events, and of hopes for the future (1976, p.73). Lowenthal (1975) concurs, suggesting that whilst places provide a psychologically comforting link to the past and previous generations of ‘us’, this continuity afforded by place also links us to our future and those of succeeding generations. When this sense of continuity is challenged, he reasons, people are motivated to recreate it using symbols of the past; he suggests this recreation is evident in the use of old place names for new locations (found so often throughout history in the naming of ‘new’ lands) and the collection of place-related souvenirs. In line with this, he maintains that place is characterised by identity continuity that extends the past into the future such that, “buffeted by change we retain traces of our past to be sure of our enduring identity” (p.9). Taking these

limitations of the existing literature into account, one of the final primary aims of this thesis is the extension of existing notions of continuity within the environmental psychology literature to include a version of place identity that forms a perceptual thread which runs from past, to present, *and* future.

In the preceding paragraphs, I have sought to argue that notions of identity necessarily involve a sense of continuity, and that places are crucial elements of self that can provide this perceived continuity, which has been presented as so vital for psychological health and well-being. During this argument several aims of the program of research reported within this thesis have been outlined.

In summary, the aims of the thesis are:

- 1) to establish whether the link between place and identity can be accounted for with reference to perceived identity continuity;
- 2) to explore the significance of the future dimension of place identity continuity;
- 3) to bring together identity process theory accounts of place and identity, with those of self-categorisation theory and place-identity theory using a social psychological approach.

Outline of the Chapters

Following the introduction of the idea that places might afford a sense of identity continuity, provided in this chapter, Chapters Two and Three will provide a full literature review of existing research that addresses these constructs in combination. This literature review will outline the varying disciplines that have discussed place, but will focus primarily on the psychological literature and will close by providing a description of the relationship between these three constructs as it currently stands. Chapter Four will discuss the key

theoretical and methodological issues relevant to the conducting of the research contained within this thesis. This discussion will involve examination of the research methods employed within the key domains identified as relevant starting points for this research programme. This thesis will draw upon mixed methods to fulfil its aims and therefore there will also be a full discussion of specific types of qualitative methodologies used in existing studies, the relationship between qualitative and quantitative methodologies, and the merit of the mixed method approach to be used.

This chapter will close with a description of the studies that will follow within the thesis. Chapter Five reports the results of Study 1, which provides initial exploration of place identity continuity in the form of twenty semi-structured interviews analysed using theoretical thematic analysis (Braun & Clarke, 2006). This study will explore specifically whether participants' relationships with places – their place identities – involve a conceptualisation of the future place-person relationship to discover whether perceived continuity derived from place identity is akin to that which is constructed within personal and social identity. In doing so, it seeks to go beyond the past and present focussed version of place identity continuity found in existing environmental psychology accounts.

Chapters Six, Seven, and Eight mark a move towards quantitative analysis of the newly developed construct 'Place Identity Continuity' (PIC) using regression-based techniques including structural equation modelling, moderated regression, and bootstrapping analyses. In Chapter Six, there is a description of Study 2, a large survey study which looks at the structure of PIC quantitatively to develop a measure of the construct, and explores the initial correlates of past, present, and future perceived place continuity. Chapter Seven describes Study 3 which builds on the survey-based design of Study 2, but looks specifically at the impact of perceived place continuity on measures of well-being whilst also cross-

validating the new PIC measure. Chapter Eight presents the final study, which is concerned with the integration of place identity research with a social identity approach by looking at the effects of social identity salience on measures of perceived place continuity, amongst other key measures, using participants' relationship with their hometown as a relevant place identification. Chapter Nine pulls the results of these studies together firstly by summarising the aims of the thesis, then reporting the main findings and conclusions that can be drawn from the results. Suggestions for improving the presented studies and potential future studies are then provided. In general it is noted that although this research marks only the beginning of a series of necessary future studies, it provides evidence that places can provide a sense of identity continuity, and that this continuity represents a relationship between people and places that is connected to both the past, present, and future and that, moreover, each of these has quite specific outcomes for identity and mental health.

CHAPTER TWO

Place, Identity, and Continuity: A Multi-disciplinary Literature Review

Introduction

In Chapter One, the central themes of place, identity, and continuity were introduced and it was suggested that a sense of continuity is a central feature of both personal and social identity. A combination of philosophical theorising and psychological evidence was then presented that indicates that this sense of continuity has a number of positive, and potentially critical, consequences for the psychology of both the individual and the group. The sources of this continuity have yet to be fully elucidated, however. In line with this observation, the objective of exploring the role of other potential identity elements in providing a sense of identity continuity was therefore set forth. Drawing on a number of theoretical perspectives from various disciplines, it was suggested that the concept of place – conceived of as a psychologically significant and socially-constructed entity – might be an important source of both identity, and by extension, perceived identity continuity. The goal of providing a specifically *social psychological* analysis of place as a source of perceived identity continuity was therefore laid out at the culmination of the chapter.

Emerging from this over-arching goal was a number of subsidiary aims. Firstly, to examine perceived continuity in relation to place identity from a more comprehensive perspective that treats continuity both as extending from the past into the present *and* the present into the future – a feature lacking in existing accounts. Secondly, by drawing on the only existing social psychological literature that has brought together the concepts of identity, continuity and place (e.g., Twigger-Ross & Uzzell, 1996), the thesis will aim to further the integration of the Identity Process Theory literature (Breakwell, 1986, 1994, 1996) with other

relevant theories of identity: Self-Categorisation Theory (Turner, Hogg, Oakes, Reicher, & Wetherell, 1987) and Place-Identity Theory (Proshansky, et al., 1983) specifically. In doing so, it is hoped that the oft called for cross-fertilization between social and environmental psychology (e.g., Bonnes & Secchiaroli, 1995; Dixon & Durrheim, 2000) might be further developed.

In order to fully explore psychological understandings of each construct, and more specifically the tripartite relationship between them, a full literature review was conducted, focusing on the interplay between place, identity, and continuity. The latter two constructs are embedded primarily within the psychological literature and as such the literature reviewed in this thesis will pertain mostly to this body of literature, and will be covered in Chapter Three. However, the former construct 'place' has been both introduced and studied just as extensively from disciplines outside of psychology, as well inside the discipline itself. This chapter will therefore begin with an account of the development of theories of place that paved the way for an understanding of the concept as a psychologically relevant phenomenon. These theories will primarily be drawn from anthropology, sociology, and human geography but will also touch upon other fields such as architectural theory. These accounts naturally lead to an understanding of place as a potential source of identity, and consequently the topic of place identity as conceived by environmental psychologists will follow in Chapter Three, specifically with reference to Place-Identity Theory (Proshansky et al., 1983).

The Study of Place

In an often quoted statement, renowned author and expert in the study of place, Delores Hayden claims, “Place is one of the trickiest words in the English language, a suitcase so overfilled that one can never shut the lid” (Hayden, 1997, p. 112). The overwhelming number of conceptualisations of ‘place’ existent in academic literature today is testament to the veracity of this statement. Indeed, many commentators (e.g., Stedman, 2002; Patterson & Williams, 2005) have identified the lack of exacting empirical findings ascertaining the links between place and behaviour as a result of the multiple developmental paths of each of the many discipline-specific notions of place: sense of place, rootedness, place dependence, place attachment, and place identity, to name only the most often used. Each of these notions will be discussed in turn, but one point of agreement is however clear: the concept of ‘place’ refers to far more than the physical environment. Each theoretical tradition concurs on the idea that place can therefore not be understood as simply location or space but must be given a more human perspective such that its role in an individual’s experience and life story may be appreciated.

This notion of place as ‘lived in’ has been echoed by philosophers who trace the expansion of the concept of place back to the writings of philosophers such as Heidegger (1973) and Merleau-Ponty (1962). These writers assert the inherency of the connection between human experience and places; a view shared by more contemporary thinkers such as Malpas (2007). Edward Casey (1997) provides a philosophical review of the history of the place construct, charting its disappearance into obscurity during the Enlightenment period and its subsequent resurgence in the 1970s as a relevant scientific topic. He too draws a clear distinction between space as location and places as both domains of interaction and integral elements of human life-stories that can be influenced by emotions, desires, and interests as

well as social and cultural contexts. He asserts that, “there is no place without self and no self without place” (Casey, 2001, p. 406). Outside of psychology, this place-person relationship has particularly been recognised by the disciplines of social anthropology, sociology, and perhaps most prominently by human geography. Each of these prominent areas of enquiry will now be discussed in turn.

Anthropological Approaches to Place

The distinctly *human* element of place has brought it to the attention of anthropologists, specifically those interested in the social and cultural dimensions of human existence. By treating human communities as based in spatial locations the discipline has successfully developed and extended its understandings of human cultural groups through exploration of dynamic processes such as ‘territorialisation’ and ‘place-making’ (Gupta & Ferguson, 1997; Low & Lawrence-Zúñiga, 2003). Setha Low (1992), in particular, has provided useful ethnographic evidence looking at the symbolic dimensions of both individual and group relationships with places. The research reveals how the affective and symbolic bonds people share with particular spaces or local pieces of land develop through the culturally ascribed meanings given to them. She suggests their part in these processes mean that connections with places are not only characterised by cognition and emotional ties, but that they are also imbued with meaning because they play a significant part in shared cultural beliefs and practices.

In subsequent years, these culturally significant dimensions of place have also been identified as the reason that they can become sources of potential contestation and conflict. For example, in a later review of the anthropological literature, Low (1996) describes the social construction of places whereby spaces are transformed into meaningful symbolic entities through social interaction, exchanges, imagery, actions, and use and in people’s

memory. This socially constructed aspect of their definition means places can lead to potential contestation between those who share attachments and identifications with one place but whose interpretations vary. Often this contestation is political and economic but it can stem from ideological and emotional causes, and therefore it is essential to examine both the social production and construction of place in order to understand attachment to place and conflict over it. This contestation is complicated by the fact that due to the symbolic foundations of these relationships, attachments can be applied to places that are solely mythical or by those who have never experienced a place first-hand – for example, in the case of genealogical claims of ownership in accordance with ‘ancestral roots’ (Nash, 2002) – as well as those that extend beyond the experiential altogether instead resulting from sociopolitical identifications and notions of citizenship (Low, 1992). Perceptions of and motives for maintaining place identity continuity might be one key influence in these processes of contestation and negotiation.

One of the main contributions offered by social anthropology to the study of place-person relations has been through the investigation of specific place characteristics that impact upon and determine these relationships. It is in these accounts that the relevance of time and notions of continuity become especially apparent. Altman and Low (1992) for example, provide a series of six types of links between people and places that can be viewed as antecedents to relationships with places. These include ‘genealogical links’ (links to one’s family and origin); ‘loss or destruction of community’ (a disruption that can highlight place relationships); ‘economic linkage’ (such as ownership or occupation); ‘cosmological links’ (religious, spiritual, or mythological significance) and ‘narrative linkage’ (storytelling and place naming). Clearly both antecedents that relate to a temporal dimension, genealogical and narrative links, might be connected to a sense of continuity deriving from place-person relationships.

In fact, anthropologists have often noted the temporal dimensions of places, specifically the role of places in symbolising both individual and social pasts. For example, in many Celtic traditions sacred places are thought to connect communities to people from their past, and this lies at the core of community relationships with place. Often described in theological terms as ‘thin places’ (Balzer, 2007), the key things to note about these places are not only their spiritual significance, but also the way they symbolise the shared social history of a people, affording them ‘sacred’ status. More specifically, one anthropological account of life in a traditional Nepalese community has revealed how these places often represent a long history where land is passed down from ancestors through succeeding generations, capturing the potentially enduring nature of relationships between place, self and others (Armbrecht, 2008). Studies such as this provide overwhelming support for the potential importance of temporal dimensions of places, such as the genealogical and narrative links described in Altman and Low’s (1992) typology. However, as anthropological approaches are largely ethnographic, few empirical studies have used their typology to conduct quantitative research. Moreover, although anthropological accounts, such as Altman and Low’s, have drawn attention to the felt aspect of relationships with place, much of the subsequent focus within the discipline has been directed at the afore-mentioned spiritual and cosmological links to place (e.g., Mazumdar, 2004; Mazumdar & Mazumdar, 1993; Mazumdar, Mazumdar, Docuayan, & McLaughlin, 2000). The writer Val Bethell (2003) describes these links nicely in her poem discussing the Welsh concept of ‘Hiraeth’: a word with no direct translation in English, it refers to the draw of a spiritual home:

"I know the meaning of the Welsh word - 'Hiraeth'. This has pulled at me all my life. I would happily travel west, but north, south or east was so difficult. I lived in a beautiful home on the edge of Wales, looking west.

The mountains shouted hiraeth, hiraeth! Silently and patiently.

One day as my material life allowed I was able to obey the call. Eureka! I now know, yes I know what it means. Hiraeth is in the mountains where the wind speaks in many tongues and the buzzards fly on silent wings. It's the call of my spiritual home, it's where ancient peoples made their home. We're high on a hill, where saints bathed sore feet in a healing spring and had a cure.

Hiraeth - the link with the long-forgotten past, the language of the soul, the call from the inner self. Half forgotten - fraction remembered. It speaks from the rocks, from the earth, from the trees and in the waves. It's always there.

Yes, I hear it. Yes, I understand what hiraeth means."

Sociological Approaches to Place

The discipline of sociology has also stressed that places are more than just physical and built, instead expressing an understanding of places as evolving, negotiated, interpreted and narrated entities embedded within society (Massey, 1994; Massey & Jess, 1995; Soya, 1996). Gieryn (2000) conducted a large review of the sociological literature, highlighting the fact that despite a wealth of sociological studies that echo anthropological interest in place-making and contestation, sociological studies of place are commonly not recognised by other place theorists. However, just as in the anthropological research, sociological theorists have also identified the role of places in embodying social history, and providing stability and durability to social structural categories (Gieryn, 2000), and hence are relevant to the current task of identifying the role of places in identity continuity.

Sociologists have also recognised the emotional dimensions of place-person relationships. Hummon (1992), for example, draws upon the notion of community sentiment to describe the ways that perceptions of a shared environment can become imbued with feeling due to people's emotional reactions to them. The combination of these perceptual and

emotional processes is therefore offered to account for the way environments become meaningful. In an early study of this topic, Kasarda and Janowitz (1974) looked at the sociodemographic factors underlying this 'community attachment and sentiment' using the results from a large survey study conducted in 1960s America. This sentiment was identified as feeling of belongingness to a residential area, interest in neighbourhood events, and pleasure or displeasure expected if moving. They identified several key influences on these outcomes including: social integration, length of residence, population size, community size, and socio-economic class. Interestingly, length of residency in the community was found to be the most important predictor of these emotions, hinting at the importance of accumulating a past history in location for development of attachments. Later authors Gerson, Stueve, and Fischer (1977) look more directly at this aspect of place relationships with a specific focus on residential mobility or stability, recognising the importance of continued undisrupted residency and by extension continued place relationships.

More recently, sociologists have drawn upon this literature and applied them to contemporary social phenomena by combining knowledge of community settlement and place-making in the context of place disruption. Samson and Gifford (2010), for example, have applied this literature to the study of refugee transitional experiences and their subsequent well-being. The young, primarily Sudanese, participants in their study have a common history of discontinuity in their place relationships due to residential experiences characterised by frequent place disruption, relocation, and resettlement. By using photo novella and place drawings combined with interview data, they have studied the effects of activities engaged in following recent arrival in Australia, identifying the role of place-making and restorative environments on well-being.

Just as in anthropological accounts, sociologists have also sought to provide typological analyses of place-person relationships. American sociologist Jennifer Cross

(2001) provided such an account in her interview study of the ways people in Nevada defined their multiple connections to place. This typology includes relationships that are: 1) Biographical (related to historical and familial bonds developed over time) 2) Spiritual (emotional and intangible bonds related to feelings of belonging) 3) Ideological (moral and ethical bonds guided by responsibility towards particular places) 4) Narrative (mythical bonds brought about by shared cultural, political or family stories) 5) Commodified (a cognitive choice based on desirability and preference) and 6) Dependent (a material connection based on constraint or dependence). Interestingly in terms of the potential connection between places and identity continuity, relationships categorised as biographically defined and characterised by long standing identity-based links are found to be the most robust and durable, being characterised commonly by an enduring sense of place identity and personal history. The issue of temporality features in other place relationship descriptions too. For example, in those categorised as ‘Ideological’, there is also some talk relating to the importance of maintaining on-going relationships with places. In those characterised as ‘Narrative’ there is also an inherent temporal dimension, with places relationships being characterised by their part in shared historical narratives expressed within family, community and cultural groups.

Notable in light of the current concern with lack of *future-related* aspects of place identity, is Cross’ (2001) further classification of place relationships (which she labels ‘Sense of Place’; a notion that will be revisited later in this chapter). Here she explicitly comments on how different types of place relationship can have varying impact on future intentions for residency. She suggests that is it relationships classified by a sense of ‘rootedness’ (a notion that will also be covered in full later in this chapter), that result in the highest levels of place satisfaction, identity strength, and importantly intentions for maintaining *continued*

residence¹. In reference to her earlier typology, she identifies these relationships as commonly resulting from biological, ideological, and spiritual bonds.

Certain sociological approaches have explicitly indicated the role that place might have in forming temporal identity. Milligan (2007) uses an ethnographic approach to study buildings as representative of collective memories, exploring how this function of certain places can influence the practice of heritage preservation. She notes that the preservationist stance frequently adopted assumes an inherent worth in maintaining historic sites, in spite of the contents of that history. This suggests that whilst places do have a symbolic role in the representation of social groups and personal history, there is also a sense that there is something intrinsically valuable about preserving history via these physical structures in our society.

In an earlier study, Milligan (2003) has also offered a direct examination of the effects of displacement on identity continuity by studying employees' use of collective nostalgia to counter negative experiences of discontinuity following relocation of their work premises. She states that, "A major source of identity continuity is the locations or types of locations within which given identities are enacted; when continuities of location are disrupted, disruption in identity continuity likely follows" (p. 382). Hence suggesting that place can be a source of collective continuity that summons a desire for reinstatement when the place feels lost. It is pertinent to note however that although the future dimension of continuity is apparent in her interviewees' accounts, the focus of this work is the role of nostalgia in enabling a sense of continuity with the *past*.

¹ This is not to imply that it is only via continued residency that places can afford a sense of identity continuity as it is possible to remain identified with a place where one does not reside. However, it is taken here as an indicator of a desire to maintain continued place identification common with continued residency in a place characterised by strong attachment.

In contrast with this, Swedish sociologist Gustafson (2001) has provided qualitative evidence for the role of continuity in the attribution of meaning to places. Situated around the central theme of the self, places cited as meaningful are deemed as representative of home, security, identity, and memory, but crucially they are often connected with a life-path theme that relates to notions of roots and continuity. Places can therefore be meaningful because they provide continuity in a self-related fashion due to their role in life-history, origins, significant experiences, and continued residency. What is more, continuity is found to be important in another sense: it is identified as a theme that relates to one of a series of dimensions underling the *processes* of attribution: the ‘how’ as opposed to the ‘why’ of place meaning. Gustafson suggests these themes are sometimes explicitly mentioned in respondents’ accounts, but often remain tacit, reflecting a ‘taken for granted’ quality of place. In this sense, continuity is inherent in the way people perceive places because they can embody social history, tradition, and temporality in general. The notion of continuity is also seen as tied up with interviewees’ discussions of place change – an inherent aspect of all physical environments. It is only in this link between place continuity and place change that any notion of the future dimension of place is tentatively broached when Gustafson suggests people make plans regarding their relationships to place under the rhetoric of personal goals and projects.

Therefore, it seems that both Gustafson (2001) and Milligan’s (2003) accounts of continuity in relation to places identify the historical dimensions of places *as places*, and the temporal aspects of place as part of the self. However, like the earlier sociological accounts, both are limited in terms of their lack of acknowledgement of the future dimension of connections between time, place, and self. As has been reasoned in Chapter One, this future dimension is not only inherent in any issues of temporality and self, but it is an important element of other sources of identity (e.g., social groups) suggesting place-related elements of

identity could also include this dimension. Moreover, although the notion of place identity is inherent in Milligan's theorising, it is not explicitly stated (or empirically tested) and the study concerns itself more with how place can allow or disallow certain personal and social roles or identifications. Whilst in Gustafson's account the focus is less on identification and more on the meaning of places, he does suggest that the identity process framework adopted by some social and environmental psychologists (Twigger-Ross & Uzzell, 1996, in this instance) is a potentially useful one. This issue will be revisited later in Chapter Three.

Place & Human Geography

In contrast to sociological perspectives that look at society and identity in relation to place, traditions such as human geography have considered the direct relationship between identity and place (see Easthope, 2009). In the 1970s, a distinct group of geographers began to reject the exclusively spatial focus of some theorists within their discipline. Instead they made a move towards a more all-encompassing *human* geography (Relph, 2008). Taking their inspiration from phenomenological theorists such as Norberg-Schulz (1971, 1980), early human geographers initiated a move away from traditional geographical approaches with an emphasis on the physical aspects of place, to explore the human experience of place. Norberg-Schulz had used both psychological and philosophical perspectives in his approach to the architecture of place, describing the 'genius loci', or spirit of place, to illustrate the experience of place as imbued with structure and meaning. Notably, even these early accounts made reference to the role of places characterised by this genius loci in providing a point of reference that can impart a sense of personal stability and significance across the life-course (Cobb, 1970).

Overwhelmingly though, the focus of these humanistic accounts was on the potential for emotional connections with places. Yi-Fu Tuan (1974, 1977) contributed a series of

seminal interpretations of positive affective attachment to place, an emotion he named “topophilia”, meaning simply “love of place”. These attachments, he reasoned, are formed through experience within places and by the security afforded by them. Not only that, Tuan also suggested that people experience a unique sense of anchorage in places, perhaps pointing to the role of places in temporal identity (Easthope, 2009). Through the phenomenological perspectives of works such as these, place gained prominence as a field of human experience worthy of exploration and the idea that place can act as an anchor for both life-history and identity has continued to resonate throughout the discipline (e.g., Ryden, 1993) .

The geographer Edward Relph (1976) was a keen leading proponent of these experiential accounts and wrote extensively on the subject of people and place. Drawing on existential perspectives such as that of Sartre (1962, cited in Relph, *ibid*), he argued that place was an essential part of what it is to be human. Relph described how people-place relations could go beyond simple interactions to a state where people become immersed in place and through that immersion derive belongingness and identity. He labelled this state of inner connection with place: ‘existential insideness’. It is from within his theorising that human geography’s nod to the link between places and self-continuity becomes most evident.

Indeed Relph (1976) alluded specifically to the sense of continuity that can be associated with significant places in his book *Place and Placelessness*. He argued that places can display persisting characteristics across time representing continuity within our experiences of change that authenticate our past life-stories, hence reinforcing a sense of association and bonding with these places. This account is similar to the sociological conclusions drawn by Gustafson (2001) that distinguish between the continuity derived from the physicality of place and from the continuity of self that places may be instrumental in providing. However, Relph’s writing goes a step further by highlighting the ways in which continuity from the physical aspects of place may impact on the continuity of the self via this

reinforcement process. Due to this process, he suggested that the intensity of these bonds increase with time in residence, particularly if one is born in that area, due to increased social knowledge, involvement, and commitment to these places as identity-relevant entities. Significantly, he proposes that, “the result of this growing sense of attachment, imbued as it is with a sense of continuity, is the feeling that this place has endured and will persist as a distinctive entity even though the world around may change” (Relph, 1976, p.31).

Of course, Relph acknowledges that, like all things, places are subject to vast change over time. Nevertheless, he identifies human practices of ritual and tradition that function to strengthen the sense of permanence associated with places. One such example is the ancient cyclical tradition of processions for ‘beating the bounds’ of villages to actively symbolise the place and reinforce its stability and continuity. Recent studies have also found evidence of these types of continuity-provoking practice. For example, Ansari (2007) has explored the way that Muslim communities have rooted themselves in areas in Britain through place-making practices such as creating Muslim burial grounds that serve to construct a sense of community narrative imbued with cultural permanence. This capturing of continuity through place-related practices has also been evidenced many times on a larger socio-political scale. For instance, in the use of cultural identity markers to create a new imagined homeland in present day re-instatements of ‘Hindustan’ in the Netherlands by Muslim Indians following their re-territorialisation since the 1940s diaspora after the partition of British India (Bal & Sinha-Kerkhoff, 2008).

Accounts such as these indicate the inherently social element of place identity and sensed continuity. It is worth noting here that this use of elements of history and culture to promote a sense of temporal continuity and boost identity is completely concurrent with social psychological accounts that focus on social identities as opposed to place identities

(see Sani et al., 2007). This concurrence constitutes only one of the many ways parallels can be drawn between these literatures, as will become apparent throughout this thesis.

Relph (1976) also highlights the inherently social nature of place attachments and continuity across time. Specifically, he suggests places can represent a link to ancestors, resulting in an overwhelming sense of commitment to certain places and unwillingness to ever leave their locale. These accounts therefore seem to indicate an inherent value in maintaining an enduring relationship between people and place. Although following this reasoning, this commitment is less likely in places that fail to represent any significant personal or social history, such as is often the case in patterns of migration and residency in modern societies. This is nicely demonstrated by observations of American migrants' compulsions to travel from their homes to visit to Europe to seek out their original roots (Lynch, 1972).

A recent geographical study has examined this practice specifically looking at Australian migrants' attempts to claim an 'ancestral homeland' by use of shared place narratives and sites of collective memory in Scotland (Basu, 2005). The author suggests that these practices function to re-root these people by forming relationships and continuities with the land. What is more, like perceived continuity in social groups, it seems that this continuity does not only link to the past but the desire to maintain on-going place connections indicates that it concerns the future too; highlighting again the importance of this future dimension of place-related continuity. Indeed, Relph (1976) suggests that place can be representative of "the present expressions of past experiences and events, and of hopes for the future (p.73); an idea which has impacted upon subsidiary disciplines such as urban planning and architectural studies. Theorists in these disciplines have noted the inherent connections between spatial and temporal identities due to the ability of place to 'concretise memory' (Dovey, 1985) and

have suggested these ‘timeplaces’ – places situated within time – are embodiments of past, present, and future time (Lynch, 1972).

Perhaps the clearest elaboration of the link between place and subjective identity continuity comes from geographer David Lowenthal (1975). Lowenthal draws on architectural observations of the desire to preserve historically symbolic sites and the emotional reactions that occur if their existence, and hence ability to evoke a sense of temporal rootedness and continuity, is challenged (Lynch, 1972). Lowenthal agrees that places provide a felt link to the past and a connection to previous generations of ‘us’, and that this sense of continuity provides a sense of security which is psychological comforting. However, he too goes further to suggest this continuity with the past, afforded by place, also links us to our future and those of succeeding generations, claiming that “buffeted by change we retain traces of our past to be sure of our enduring identity” (Lowenthal, 1975, p.9). Moreover, whenever this is challenged people are motivated to recreate that sense of continuity using symbols of the past; this he suggests is evident in the collection of place-related souvenirs and the use of old place names for new locations (as evidenced in the above sociological examples of ‘Hindustan’).

Two distinct messages relevant to this thesis emerge from a review of the human geography literature. Firstly, place should be defined in accordance with a set of multiple interwoven elements: the physical location, the socio-cultural context, and a felt experiential dimension. As a consequence, the task of producing analyses that acknowledge the interplay between all three elements of place has been levied at the discipline by several theorists (e.g., Agnew, 1987). Secondly, there is a distinctly temporal aspect of place; specifically, the physical dimensions of places seem inextricably linked with a sense of continuity across time. Furthermore, the literature suggests this not only affords a sense of continuity of place, but also a continuity of self via personal and social connections with

place. This point is crucial to the propositions set out in this thesis, but what is also significant is the way that this continuity has been connected with the future and not simply with the past.

These issues will become even more crucial when examining the current literature in psychology but before embarking on that task it is necessary to create a segue into significant studies emanating from various other disciplines that have also turned their attention to the relationship between people and places. This involves drawing upon various alternative definitions of place-person relationships that have included constructs such as ‘place dependence’, ‘place commitment’, ‘insideness’, ‘rootedness’, and ‘sense of place’; I will focus on the last two, as they have been the most productive in terms of place and continuity.

Rootedness

Some authors have approached the human significance of place by reference to the concept of 'rootedness', also situated within human geography. Relph (1976) describes this concept as relating to a series of emotional experiences including a sense of knowing and being known in a place, a strong sense of familiarity with it and concern for it, and above all a feeling that this particular place represents one's ‘roots’. Philosophers have long recognised the need for roots as a core human need (e.g., Weil, 1955). Indeed Heidegger (1971) even spoke of the importance of ‘dwelling’ – simply being at home in a place of one's own – as a core feature of human existence. Just like alternative formulations of place, the notion of rootedness has been linked with positive outcomes. Relph (1976), for example, identified a sense of roots in a particular place as constituting a secure haven to negotiate from and to garner a sense of meaning. Yi-Fu Tuan also wrote extensively on the symbolic nature of these experiences of deep rooted connection, stressing the inherence of these

relationships in everyday language exposed in commonly used terms such as ‘motherland’ (Tuan, 1977).

The notion of rootedness by its nature includes a sense of continuity. Concurrently, researchers interested in feelings of rootedness in residential settings have found this perception to be primarily associated with a sense of belonging and length of residency, and to be predictive of attachment to places (McAndrew, 1998). In his Pulitzer Prize winning book, psychiatrist Robert Coles (1972) approaches the concept of rootedness in his illustration of the significance of places identified as ‘home’. He does so using an interview account given by a North American farmer who describes home as, “a place that you have and your kin always have had and your children and theirs will have, until the end of time” (p.358). Together these sources suggest, that feeling at home in a place is derived from accumulated time spent in place, combined with the sense of belonging to that place. This sense of belonging and attachment seems further intensified, developing into a sense of rootedness, if the temporal connections associated with that place exceed individual lifetimes. This leads to a sense of continuous linkage to those places often realised by their connection with preceding generations of family or community members. In this sense, as well as concurring with sociological, anthropological, and geographical definitions of place relationships, rootedness proves itself to be a useful concept by emphasising the role of social identifications in place identity, and place identity continuity.

Sense of Place

Another approach to the relationships between people and place has been in the study of a ‘sense of place’. This sense of place literature has echoed earlier accounts of place importance by focusing on the emotional elements of place relationships. Tuan (1980) has put forth a definition of sense of place as the result of an individual’s reflections regarding

their connections with place. Specifically, it has been identified as a combination of emotion and attention that leads to specific perceptions underlying the development of attachment to places, therefore containing both 'sensing' and 'bonding' elements (Hay, 1990, cited in Hay, 1998b). As such, the concept is often theoretically subsumed by the notion of place attachment. However, sense of place research aims to go further than simple attachment by examining the impact of particular social and geographical contexts on the development of sense of place (e.g., Hay, 1998a, 1998b).

Jorgensen and Stedman (2001, 2006) have treated sense of place as an attitudinal concept made up of feelings about the place, beliefs about the place-person relationship, and behavioural tendencies resulting from commitment to the place. The authors suggest that this multi-dimensional approach to sense of place encompasses place identity, attachment, and dependence and suggest that it is therefore more predictive of residential behaviours than these single variable approaches. Whilst this work has been valuable in recognising the components of place-person relationships, the literature has commonly been criticised for missing the dynamic, multi-dimensional character of place relationships and for basing conclusions on the limited range of places commonly studied, which rarely moves beyond household or local community (Manzo, 2003). This means that the complex relationship between person and nation, for example, is largely unexplored.

Perhaps the most important research for the study of continuity is Hay's (1998) study of the development of sense of place. Using interview and survey methods the study identified a tendency for strong sense of place to develop for those who have long periods of residency, particularly if participants were 'raised' in a place. Cultural and ancestral links were therefore found to be significant precursors to experiencing a sense of place, helping to promote the place as an 'anchor for identity'. Crucially, Hay also suggested that although the

current societal context makes it a difficult task, a sense of place based on these types of cultural and ancestral bonds should be promoted in light of the psychological benefits of the 'rooted' sense of place they enable; a sense characterised by feelings of stability and importantly, continuity. Several other studies have supported these conclusions.

One such study is the sociological interview study of sense of place discussed earlier in which Cross (2001) also concluded that biographical relationships characterised by a long residency where places represent part of personal history, are characteristic of the strongest relationships with place. Through this process, people and place become incorporated within each other in a manner that is often experienced as valuable and positive. This positive evaluation is evident in the following account provided by one of the interviewees: "I feel like I'm a part of this place. I'm a part of the history. When I go into the supermarket, I know so many people. I'm just really happy living here. My kids are sixth generation". It is pertinent to observe that the experience of this reciprocal relationship between self and place affords the individual a place in something viewed as meaningful and characterized by a sense of temporal endurance.

A recent interview study by Hawke (2011) lends further support to this conclusion. The authors using this literature as a framework to explore the impact of cultural heritage on sense of place in the England's North Pennines. Through deductive coding of the data in line with previous sense of place and the identity process literature that will be covered later, she concludes that this engagement in heritage practices helps promote feelings of pride and distinctiveness through participants' relationships with these protected places. Moreover, she notes they engage in 'memory talk' that helps locate them temporally within the past and present in line with these places; crucially, therefore allowing them to achieve "senses of continuity across time" (p 1331) that further reinforces their sense of place. It is to these

specific perceptions that the majority of their data point, concurrent with the idea of temporality inherent in notions of heritage protection.

Conclusions

A review of the above literature has pointed towards the inherent value and emotional elements of human relationships with places. It is, however, crucial to recognise that being entrenched in one place is not beneficial in all circumstances, especially in present day culture when definitions of success are often bound up with notions of mobility.

Furthermore, not all outcomes of sense of place are positive. For example, just as in the sociological accounts explored earlier, several authors have identified the socially constructed nature of sense of place arguing that these emotional bonds with places are in a state of perpetual flux, negotiated and renegotiated at both individual and social levels (Williams & Stewart, 1998). This realisation has countered notions of sense of place as primarily positive by exposing place as a context for place-making practices that can express a multitude of social, ideological, and power relationships, often for politically-oriented outcomes (Stokowski, 2002).

Nevertheless, research in both rootedness and sense of place represents advancement in the theoretical conceptualisations of the significance of place and is concurrent with more general sociological and geographical approaches to place. Moreover, both research traditions have pointed towards the significance of the temporal dimension of place-person relationships and have been suggestive of the ability of these relationships to provide a sense of identity continuity. Most theorists also agree that these types of emotions related to place can be critical to the psychological health of many populations (e.g., Rowles, 1983). In line with this, it follows that if as suggested this temporal dimension strengthens connections to place then it is possible that a sense of place identity continuity will also influence

psychological well-being. Importantly, unlike earlier approaches, both research areas have also developed beyond theory to empirical investigation. Validated measures of rootedness have been found to predict attachment and patterns of residency (McAndrew, 1998), for example, and emotional and cognitive dimensions of sense of place relate to attitudes towards specific types of residency (Jorgensen & Stedman, 2006).

Despite these merits, Kyle, Graefe, Manning, and Bacon (2004) have suggested that concepts such as rootedness and sense of place, as well as the afore-mentioned insideness and place dependence, are all simply concepts relating to different aspects of place attachment. Whilst some authors have drawn important distinctions between them – Tuan (1980), for example has differentiated between the terms sense of place and rootedness, describing sense of place as an awareness of a positive feeling for a place and rootedness as a feeling of ‘being home’ – there is a general consensus that the use of these multiple terms can hamper further empirical investigation of emotional bonds with place, and by extension any research that seeks to look at the functions of these relationships. Moreover, the differing research strands are seen as primarily indicative of the lack of definition of the general concept of place attachment (Giuliani, 2003). Concurrently, some researchers have suggested separation of the concepts for research purposes is untenable (Hay, 1998b). It is therefore towards an examination of this overarching concept of place attachment that attention will now turn.

The following chapter will begin by asking specifically if, like the sociological and geographical literature, the place attachment literature recognises of the role of place in subjective continuity. As this body of work resides in the psychological literature, this section is also a point of departure from non-psychological literature into research conducted primarily by environmental and social psychologists. Chapter Three will therefore review the psychological literature on place, identity, and continuity, before providing an integrated conclusion on the literature reviewed there and in this chapter.

CHAPTER THREE

Place, Identity, and Continuity: A Psychological Literature Review

Introduction

The work of human geography, sociology, and anthropology converge on many points but one resounding conclusion they all point to is the psychological impact that places can have on people. This means that despite the breadth and depth of insights offered by these disciplines, it is necessary to move beyond them to look specifically at what psychology has to offer for an understanding of these pervasive place-person bonds. The first key theoretical domain offering some explanation of the psychological significance of place is centred on the notion of 'place attachment'. This literature makes a good departure point from these earlier disciplines as it is heavily influenced by the experiential theories of human geography (e.g., Relph, 1976; Tuan, 1980), yet is psychological in both essence and method.

This literature is limited by its solely emotional focus but its interactional nature leads directly to discussions of place and self, and as such a narrowing of focus towards self and identity in relation to place. Consequently, reference must be made to various areas of psychological theory that describe the relation between environment and identity, specifically the identity theories found in environmental psychology, social psychology, and to some degree discursive and political psychology. Each of these literatures will be described in turn to explore psychological understandings of place and self, and then more specifically to identify where they have touched upon continuity of identity and place. At the culmination of these accounts, it will then become possible to identify what issues remain to be addressed in the research documented in this thesis.

In order to fulfil these aims, this chapter will move from a description of place attachment research to a summary of the problems inherent in the place identity literature. Discussion will then turn towards a review of the social psychological studies that have successfully incorporated the concept of place into their theorising on identity. This literature will include reference to research emanating from the social identity approach, but will focus primarily on the most fruitful identity theory to incorporate place continuity: Identity Process Theory (Breakwell, 1986, 1992, 1996). It will then be suggested that the nexus between these two theoretical approaches within social psychology not only affords opportunities for the multidisciplinary development of an understanding of the relationship between place and identity, but that it also constitutes an appropriate and potentially fruitful context for a comprehensive study of the notion of place identity continuity.

Environmental Psychological Theories of Place

Place Attachment Theory

Place attachment can be defined simply as an affective bond with a place, an experience that researchers in this tradition believe most humans have experienced in one form or another at some time in their lives (Giuliani, 2003). However, to rely on a simple definition denies the sublime intricacies of these phenomenological relationships. Altman and Low (1992, p.5), for example, describe the complexity of this bond by noting that it is, "...an interplay of affect and emotions, knowledge and beliefs, and behaviours and actions in reference to a place" and others note these relationships are "beyond cognition, preference or judgement" (Riley, 1992, p.13). The ubiquitous nature of these emotional bonds with place means much has been written about place attachment in disparate disciplines such as environmental sciences, town planning, and architecture, as well as environmental psychology. This is due in no small part to the geographical and sociological accounts

discussed earlier that emphasise the role of emotion in place-person relationships. However, as place attachment has sometimes been labelled as the extent to which an individual values or identifies with a particular place (Altman & Low, 1992), it has often been the case that place attachment has been used as a proxy for place identity. Although Proshansky et al. (1983) are keen to clarify its status as only the affective component of place-identity, a construct which will be discussed fully in the next section of this chapter.

On the whole, within the discipline of psychology, the cognitive and behavioural elements of person-place relationships have been the main interest of environmental psychologists, leaving the emotional elements largely untouched. However, as the above literature has suggested, these emotional elements have proved pervasive features of place with potentially significant behavioural outcomes, rendering them worthy of study. Favourite, pleasant, and unpleasant places, for example, evoke reactions ranging through multiple dimensions of positive affect, through to fear and arousal (Korpela & Hartig, 1996). Moreover, some types of natural and built environments have also been ascribed health-giving restorative properties (Scopelliti & Giuliani, 2004). Importantly, concerning the present interest in the temporal aspects of place-person relationships, place attachment has also been defined as a bond between individual and place characterised by a tendency to stay close to a place, and maintain connections – be they residential or otherwise (Hidalgo & Hernandez, 2001).

Particular theoretical attention has been paid to emotional links to home reflecting its primacy as a place involved in giving meaning to the self. Various qualitative studies have explored the meanings of home that feature in respondents' accounts of their home (e.g., Rowles, 1983). However, this work is largely descriptive and not linked to any specific theories of self (Giuliani, 2003; Moore, 2000) and the study of place satisfaction and its

behavioural consequences, e.g., residency, is one of the few areas of study where there has been any attempt at defining the theoretical underpinnings of place attachment theory itself. This lack of theoretical elaboration has been linked to the propensity in the place attachment literature to ignore attachment theory proper; a neglect that is considered surprising by some as John Bowlby's (1959) work on mother-infant attachment featured reference to the psychological significance of the near environment and suggested that individuals might become attached to places as well as people (Giuliani, 2003). Moreover, human geographers have agreed that the act of homemaking reflects a basic human need (Relph, 1996). Giuliani (2003) has therefore suggested that the tenets of attachment theory be extended to acknowledge attachment to place, just as they have been usefully applied to interpersonal and social domains (e.g., Baumeister & Leary, 1995; Mikulincer & Shaver, 2005; Smith, Murphy, & Coats, 1999). He maintains, this theoretical framework may help provide an account of both typical and atypical relationships with place by particular examination of "the role of early experience in influencing late psychological outcomes" (p. 140).

Research has shown that the places of childhood are particularly significant and usually involve a large degree of attachment (Rubenstein & Parmelee, 1992). This is something that has been acknowledged by theorists in many different disciplines throughout history. For example, Cobb (1970) reasoned that the places of childhood are conducive to discovery of the self because significant locations have the potential to be transformed into 'my place'. The places to which the child forms an attachment therefore have a distinct significance and so are revered in memory (Relph, 1976). In this way, they may be considered building blocks of identity in a similar way to cherished possessions, peer groups, or significant events. Giuliani (2003) suggests that secure place attachment in childhood is particularly important in the development of identity and that satisfaction of early place attachments facilitates later explorations and attachments. This is a concept borrowed directly

from Bowlby's theorising but subsequent research on childhood place attachment seems to support this idea finding that places represent security and familiarity as well as discovery (Chawla, 1992).

As childhood places have been identified as potentially some of the most significant in the array of places an individual may feel a connection with across their life span, it follows that they too might also be connected with a sense of self continuity; perhaps even being a particularly crucial source of continuity. Theory in alternative disciplines suggests this is the case. The geographer Dardel (1952, p.46), suggests, for example, that the geographical reality of man is, "the place he is in, the places of his childhood, the environment which summons him to its presence". Moreover, these childhood places have been associated not just with a connection to the past of the individual but also for their sense of the future. Indeed, the philosopher Albert Camus writes that the memory of ruins he knew as a child provided him with an *ongoing* sense of stability and meaning throughout life (Camus, 1955). It is however, crucial to realise that people can become attached to places at any stage of their life. In fact, old age has been identified as another key life-stage where place attachment is particularly apparent both because of the role of places in memories of earlier life-stages and because familiar local identity can afford a sense of self-esteem at this often challenging time of life (Rubenstein & Parmelee, 1992).

The place attachment literature has also offered another approach to studying place-person relationships within which the role of continuity becomes apparent. This approach has been motivated by human geographers' study of lack of place attachment, which they have often conceived of as *rootlessness* or *placelessness*, and frequently associated with negative consequences (Relph, 1976; Tuan, 1980). Their approaches have suggested that place attachments might not always be apparent to observers or the individual themselves.

This can be because there are many different levels of place attachment and their expression can depend on intervening social variables. However, they suggest that place attachment may become salient when emotions are triggered via a *loss* of place, what might be considered as a break in the continuity of the bond between person and place (cf. Milligan, 2003).

These focussing effects of place loss have meant that one approach to the study of place attachment is to focus on the occurrence of place disruption (Brown & Perkins, 1992). In one of the first studies to look the emotional aspects of place, Fried (1963) conducted a psychiatric study of place attachment processes by examining residents' reactions to a forced relocation in Boston. Using interview data he argued that this dislocation of place led to strong negative emotional responses akin to grief. Unfortunately, these emotional responses are often difficult to access because of the complexity of verbalising these frequently taken for granted emotions linked to the places we call our own. For example, Lifton (1967) provides a description of a survivor of Hiroshima whose experience of seeing Hiroshima itself destroyed, even in comparison to some of the awful sights he bore witness to, was so shocking he could not put his emotions into words. Relph (1976) reasoned this sense of indescribable emotion is resultant from the deep-seated psychological and existential ties people can have to places they feel attached to. This intangibility can make their role in identity even harder to grasp, as Lalli (1992) contends, "the state of identification with the environment is largely unselfconscious and becomes aware when threatened" (p.287). One factor underlying these grief experiences may therefore be a combination of the loss of the knowledge that the place is available, as part of the individual, persistent across time and the loss of security and sense of self this knowledge provides (Relph, 1976).

Despite the methodological difficulty associated with describing these potentially imperceptible relationships, there have been some notable contributions to the study of emotional reactions to loss of place; be it via complete destruction of a place, removal from place, or by such change that a place loses its recognisable identity. In addition, each of these accounts touch upon the idea that this dislocation from place can represent a break in place-related continuity. For some authors this break is due to the loss of the physical characteristics of the place, that is, the *actual* place continuity as opposed the place identity continuity, as discussed earlier in this chapter. That is to say that because physical features of places are thought to cue the symbolic meanings of the place, dislocation and displacement can disrupt access to the place features therefore damaging the attachment experience (Stedman, 2003).

These features, often historical in nature, can represent a link to memory and the past, and as such, a sense of continuity. By embodying group history and culture, they connect to the social groups they represent. In support of this idea Lewicka (2008) provided questionnaire data showing that Polish cities with more historical sites, reminders of the past, and successive generations of residents, were characterised by higher levels of place attachment amongst residents than those without. Furthermore, Rubenstein and Parmelee (1992) suggest that one explanation of the association between length of residency and increased place attachment is that place-located memories are built up over time allowing a sense of continuity within one's life.

The discipline of psychiatry has also provided an examination of this phenomenon, its subjective experience and psychiatric consequences, through the study of 'root shock' (Fullilove, 2001). This term is based on an analogy from botany whereby a plant is placed under trauma by forceful extraction at the roots. This analogy is used to make sense of the psychiatric trauma that results from processes such as urban renewal which have uprooted

entire communities in some cases (Fullilove, 1996, 2001). In her book exploring the importance of place in her family story and its role in development of the self (or “rooting in place”), Fullilove (2002) describes a similar sense of confusion, sadness, and loss often experienced on return to changed significant buildings such as those from childhood or particularly relevant times of identity development. She explores the ways that loss of home and neighbourhood can affect a sense social bonding and belonging and consequently interactions within communities and other social groups; concurring with the social psychological literature on perceived collective continuity and social well-being (Sani et al., 2008a). Interestingly, even in Fried’s (1963) original work on the breaking of place attachment bonds there is suggestion that a loss of continuity of place may underlie the emotions experienced by residents.

The study of place attachment to what is considered ‘home’ has also emphasised the role of place in subjective self-continuity. Although home has been considered a potentially confusing multi-definitional construct by some (Moore, 2000), there appears to be some general consensus on its necessary features. This typically includes elements such as safety, retreat, and self-expression, but importantly home has also been linked to permanence and identity continuity (Somerville, 1997). This temporal dimension of home and the desire for it to represent some kind of permanence often features in people’s accounts of home, particularly for those challenged by geographically mobile family lives (Allen, 2008). Fried (2000) has also recently extended his study of place attachment with a focus on a sense of continuity with place, noting that although in some sociological conditions powerful attachments to place can be detrimental, people often do still display a desire for continuity gained through attachment to their communities.

Place attachment research has offered up some interesting theories and qualitative research, and in particular has highlighted the link between attachment places and subjective continuity. However, although the construct can now be measured with a variety of scales (e.g., Williams & Vaske, 2003), its lack of theoretical elaboration remains a problem for constructing subsequent procedural accounts (Giuliani, 2003). Nevertheless, one potentially fruitful integrative approach has been focussed on identifying the relationship between place attachment and the related construct of place identity, despite some problems with extracting precise relationships due to the numerous ways place attachment has been conceptualised (Hidalgo & Hernandez, 2001). For example, in some cases, place attachment is thought to subsume place identity (Kyle, Graefe, & Manning, 2005), and in others they are both subcategories of another construct, for example, sense of place (Jorgensen & Stedman, 2001).

Place attachment theorists have nonetheless attempted to look at these constructs in combination to promote a fuller understanding of person-place bonds that includes cognitive, as well as emotional, aspects of place attachment bonds. They suggest that bonds to places are significant as they not only link us to places which seem to have an impact on sense of self therefore guiding identification with places, but they may also affect behaviour towards the places themselves and to others who may share that place identity (Giuliani, 2003). Chow and Healey (2008), for example, have recently successfully used both of these constructs to understand the impact of place attachment and place identity on student experiences of transitions to university. One of the key characteristics of studies such as this one is that they reason that it is through the process of attachment that place identity develops by facilitating the construction of self (Moser & Uzzell, 2003; Rowles, 1983); a conclusion that has significant ramifications for the understanding of place identity continuity, its development and potential psychological outcomes. It is towards an exploration of this link between place identity and continuity, specifically through the lens of leading identity

theories that this chapter will now progress, but first some words of caution about the preceding conclusions are necessary.

Whilst the work of human geography had a substantial impact on place attachment research in environmental psychology by highlighting the psychological significance of residential stability, it is essential to avoid an overgeneralised understanding of the primacy of long-lasting, historically-based place attachments. Giuliani (2003) points out that although some authors interpret the work of both human geography and Fried's (1963) early work as suggesting a sense of attachment and residential stability are *necessary*, Fried has cautioned that a sense of continuity is not always contingent upon the stability of place and people necessarily but is the case in only *some* circumstances. In fact, he suggests that ongoing 'fixed' place attachments may be less than ideal in some circumstances by limiting human adaptation and making the seeking of new opportunities more difficult; in other circumstances they are potentially disastrous where disputes over ownership and territoriality can ensue (Fried, 2000).

Moreover, in a French doctoral study by Bahi-Fleury (1996) looking at place bonding and the connections between residential history, attachment and identity with 180 residents in various areas of Paris, length of residency was found to have little association with attachment. Instead it was found to be more important whether residents felt they 'chose' to be in the area; an idea that appeals to recent moves to breakdown place attachment in to traditional versus active types (Lewicka, 2011a). The study also showed a significant impact on place attachment of positive and negative childhood and adolescent experience, and the acceptability of cultural stereotypes of Parisian versus rural identity in respondents. Each of these findings suggests that it is dangerous to presume that place identity continuity is either universally desirable or due to a developmentally uniform experience. Nonetheless, its role

in place identity seems potentially significant as the literature reviewed below will demonstrate.

Place Identity Theory

Theories of place identity have their roots firmly in the discipline of environmental psychology: a discipline where the psychology of place is at its most apparent. Arising from a Lewinian concern with the application of psychological methods to real-world issues, the discipline arose almost simultaneously in the United States and in the United Kingdom during the 1960s and 1970s through a combination of developments in architectural and ecological theory (Bonnes, Lee, & Bonaiuto, 2003; Bonnes & Secchiaroli, 1995). Since its inception it has attempted to pull together theorising from disciplines outside its own and apply a psychological perspective to them to facilitate empirical exploration of environmental concepts.

Early work looking at the effects of specific residential environments on behaviour pulled together researchers working in various research traditions exemplifying this interdisciplinary inception and an early deterministic interest in the physical aspects of the environment. However, by the time the first handbook of environmental psychology was published in 1987, the focus was clearly stated as the relationship between the *sociophysical* environment and human behaviour and well-being (Stokols & Altman, 1987). This shift reflects the rejection of earlier behaviouristic small-scale approaches in favour of larger-scale transactional approaches that incorporated the effects of the ‘sociophysical milieu’ into their interactive accounts of person and place (Canter, 1977; Stokols, 1978; Stokols & Schumaker, 1981). However, it also demonstrated the dual influence of cognitive and social psychology, whose methodologies were of primary use to the nascent discipline (Bonnes & Secchiaroli, 1995).

The definition of the 'environment' employed in this disciplinary context is exceptionally broad, including both natural and built settings, at physical and social levels that extend from the local to the global. This approach allows it to address human-environment interactions on multiple levels and domains, and with a multitude of research aims that are largely problem-oriented (De Young, 1999). Having said this, several specific themes have emerged over time. Specifically, issues surrounding subjective perceptions of the environment, conservation, attention, cognitive representation, participation, preferred environments, and finally environmental stress and coping (De Young, 1999; Kaplan & Kaplan, 1982). It is worthwhile to note that whilst the issue of continuity has been little studied as a primary focus of these research programs, the last two of these main themes do hold some relevance. For example, the idea that there can be 'preferred environments' has pointed towards the emotional component of place interactions (Bonnes & Secchiaroli, 1995). More precisely, links have been made between well-being, a sense of coherence, and the preservation and restoration of environments. Issues of environmental stress have also included some consideration of the effects of lack of continuity, usually in the context of displacement. These literatures will be discussed in turn below.

Despite these few links to continuity, the discipline on the whole has given most attention to topics such as environmental design, planning, management, and cognitive mapping. Consequently, its study of behaviour and social problems has remained concentrated on examining the outcomes of specific environmental features and the factors determining pro-environmental behaviours (De Young, 1999). However, the crucial issue of identity has permeated throughout the history of environmental psychology. One of the first dialogues on the concept of identity featured in Fried's (1963) work on place attachment, discussed earlier, where he noted the significance of what he termed 'spatial identity' in peoples' bonds with their local environment. Specifically, he noted the effects on this sense

of identity following a loss of these bonds. Several theorists have subsequently noted this link between place attachment and identification processes, suggesting that a strong sense of attachment may precede identification with places, although this has led to some conceptual obfuscation between the two (Giuliani, 2003). However, the most notable contribution within environmental psychology for present purposes is the development of the concept of 'place-identity'.

Harold M. Proshansky at City University New York first introduced the term place-identity² in his seminal publication *The City and Self Identity* where he presented this new concept rather broadly as, "those dimensions of the self that define the individual's personal identity in relation to the physical environment by means of a complex pattern of conscious and unconscious ideas, beliefs, preferences, feelings, values, goals and behavioural tendencies and skills relevant to this environment" (Proshansky, 1978, p.155). This located notion of identity arose out of the new disciplinary framework set out by environmental psychology where it acted as a specific response to the previously dislocated conceptions of identity that existed in psychology, and from calls for more ecological notions of self from areas such as personality psychology (e.g., Craik & McKechnie, 1977). The resulting place-identity theory suggested that every identification a person experiences as a result of their specific social roles is also impacted upon by certain physical environmental elements that are subsumed within that identity, thereby recognising the importance of places as sub-components of the self-concept.

As well as these specific place identifications, Proshansky also presented a distinctively developmental account of the existence of a generalised place-identity, specific

² The term 'place-identity' is the hyphenated form specifically used for the construct in Proshansky's (1978) Place Identity Theory. However, later uses of this concept tend to refer to 'place identity' and as such, the original term will be used only in relation to Proshansky's theory.

to each individual. For example, Proshansky et al. (1983) described how this collection of place-related cognitions, behaviours, and emotions can develop into a relatively stable sub-structure of the self-system as a direct result of each individual's interactions with places. According to this account, children are said to first associate themselves with distinct childhood places and use them as the lenses through which to evaluate, create, and interpret all further places. The place-identity is then said to be modified and developed across the life span fulfilling certain psychological roles and performing specific functions including the provision of recognition, meaning, expression, change mediation, defence, and anxiety management. All places experienced are then compared to this core place-identity (Proshansky et al., 1983; Proshansky & Fabian, 1987).

This theory therefore not only recognises identifications related with specific places but it also describes place-identity as a generalised sub-identity representing the 'physical world socialisation' of the person; that is, incorporating experience with *multiple* places (Proshansky, 1978). This reflects a core tenet of theory: the idea that each individual has an 'environmental past', which consists of all the places, and their features, which have had an impact on the individual in his or her past (Proshansky et al., 1983). In sum, Proshansky's place-identity theory marks one of the most dominant and all-encompassing accounts of places as significant components of the self-concept. Components that, according to this theory, are as important in terms of the self as other aspects of identity such as social class and gender (Proshansky & Fabian, 1987).

Whilst the dominance of the place-identity model is undeniable in environmental psychology and it represents a significant advancement in definitions of place-related self, it has been characterised by several key limitations. Dominant critiques are primarily related to the theoretical underpinnings of the approach, its theoretical clarity, and its lack of connection to alternative models of identity (Twigger-Ross, et al., 2003). One of the major

problems relates to its lack of procedural explanations, which has left the processes and structures of place-identity hard to pin down and research providing any sound empirical conclusions clearly lacking (Dixon & Durrheim, 2000; Korpela, 1989; Manzo, 2003; Speller, et al., 2002; Twigger-Ross & Uzzell, 1996). This problem has led to some quite specific critiques. The developmental accounts and hypotheses offered, for example, have been identified as incompatible with other models of identity, meaning that its developmental processes remain vague and it is unclear whether the functions satisfied by place-identities are unique to this aspect of identity (Hauge, 2007).

This lack of clear description has resulted in the contested character of the construct, and an absence of clear operational descriptions that both hamper further empirical examination and lead to a confusing variety of measurement and structural approaches (Hidalgo & Hernandez, 2001; Lalli, 1992; Manzo, 2003; Pretty, Chipuer, & Bramston, 2003; Twigger-Ross et al., 2003). Some say this lack of conceptual clarity results from a scarcity of dialogue on the part of the multi-disciplinary research groups working in environmental psychology (Patterson & Williams, 2005). What is clear is that this particular account of place identification remains largely under-utilised, and its interpretations of identity are thought of as largely unconscious and schematic (Hauge, 2007; Twigger-Ross et al., 2003), perhaps due to its understandings of place as the cognitive backdrop to experience (Proshansky, et al., 1983).

Despite these inherent problems, more defined formulations of the construct were to follow. Korpela (1989), for example, defined place identity as psychological structure created via the individual's attempts to regulate their environments. According to this definition, individuals can derive a coherent sense of self and present that self to others through usage of the surrounding environments. A sense of belonging has also been defined as an important element of place identity and it is argued that only following this 'place-

belongingness' can cognitive and definitional elements of place identity form. Other researchers have provided further definitions with some as simple as place identity being the incorporation of place into self (Krupat, 1983). However, despite the varying descriptions, there is general consensus that people actively use places to develop and represent a sense of self, meaning, rootedness, and attachment via their interactions and personalisation of self-relevant places.

Further conceptualisations have identified specific features of place identity. For example, place identity is considered a 'nested' phenomenon such that a person may have identifications with various levels, for example, home, community, or nation (Cuba & Hummon, 1993). In light of this, some authors have attempted to classify the hierarchical relationship of these identities in terms of importance. For example, Rubenstein and Parmelee (1992) suggest more personally-defined place identities might have a primary role in identity. However, this denies the potential for larger scale socially-based place identities to become salient, and hence of primary importance, in certain contexts (Twigger-Ross et al., 2003). Indeed the fundamentality of socially-defined place identification has been repeatedly demonstrated. For example, Cuba and Hummon (1993), found that respondents often choose larger-scale shared place identities like region and community, as opposed to dwelling, when asked which kind of place they most feel at home in. Both this nested and variably-accessible nature of place identity go some way to support the compatibility between theories of social identity and those of place identity: a key issue for this thesis.

Following an extensive review of the place-identity literature, Lalli (1992) echoed concerns both over the need for convergent theoretical foundations and the lack of large-scale social dimensions of place identity research. His key finding related to the limited range of spatial extension involved in place identity research and this led him to use focus on what he named urban-related identity using a social psychological framework. In contrast to the

existing environmental psychology work of that time, Lalli paid particular attention to the social elements of identity by arguing that social identities such as the sense of local community could impact upon the individual's sense of urban place identity. Following this lead, subsequent studies have also begun to address the social elements of place identity (e.g., Auburn & Barnes, 2006; Bonaiuto, Breakwell, & Cano, 1996; Pretty, et al., 2003), but despite this development place identity is often still considered fundamentally individualistic in its general approach (Dixon & Durrheim, 2000; Twigger-Ross, et al., 2003).

As well as providing an impetus for drawing together social and place identity literatures, Lalli's (1992) work provides further support for the current aim of theoretical integration with Breakwell's (1986, 1992, 1996) identity process literature. Specifically, his work initiated a move towards looking at the processes that might guide the construction of place-identity. He suggested that urban-related identity may help in the acquirement of a sense of self-esteem and distinctiveness, both guiding principles in identity process theory. This complimented work outside of place identity research, where a few authors looking at the self-regulating role of place attachment had also looked at identity processes suggesting that attachment relationships can restore self-esteem and promote identity coherence (Hartig, Mang, & Evans, 1991; Korpela, 1989; Korpela, Hartig, Kaiser, & Fuhrer, 2001). In addition, these studies identified people-place relations as crucial in satisfaction of identity motives such as sense of security, control, belongingness, relatedness, and positive affect.

Of primary significance, however, is the fact that some of the place identity literature also pointed towards issues of temporality and continuity in relation to their place identity conceptualisations. Feldman's (1990) study examined what she termed 'settlement-identity', conceptualising this in terms of participants' choice of place type considered to be most indicative of their identity (rural versus urban, for example). Crucially in terms of place-related continuity she noted that people who live in an area that is not concurrent with their

own preferred type of place identity experience a sense of ‘temporal dislocation’ from their settlement-identity; this was experienced in a similar manner to those who describe the rupture of place attachment bonds. This observation is concurrent with studies housed in the cross-over between place identity and identity process literatures that will be explored in the subsequent sections of this chapter, which show that people will often chose to live in places consonant with their sense of appropriate place identity (e.g., Twigger-Ross & Uzzell, 1996) .

Feldman (1996) also reported that in some cases these residential decisions are influenced by the primacy of particular life stage identities, such as, ‘divorcee’, ‘young person’ or ‘mother’, which themselves transmit normative expectations about appropriate types of place identification. Again, these findings connect place and social dimensions of identity, and illustrate the potential context-specificity of place identity, aligning the theory with social identity principles. However, this finding also illustrates the role of places in narratives or life-stories, a literature which has for many years highlighted the importance of subjective continuity (Conway & Hague, 1999; McAdams et al., 2006). This goes beyond the simple role of place in providing environmental constancy to facilitate memory, and hence continuity (Bluck & Alea, 2008). Instead this notion is more akin to Rowles’ (1983) ‘autobiographical insideness’: an aspect of identity brought about by attachment and rootedness to place across autobiographical time, which emerged from his ethnographic study of place relationships with elderly residents of an Appalachian community.

Just as in the place attachment literatures discussed earlier, when using these life-cycle perspectives the real significance of continuity in the place identity literature is demonstrated under conditions that threaten feelings of continuity. Cuba and Hummon (1993) use such a perspective to study situations of ruptured place continuity, in this case whilst exploring the effects of migration on place identity. Using an interview study, they examined migrants’ constructions of a sense of home using place affiliations. The results

suggest people have different primary affiliations at different stages of life. For example, they note that younger people are more affiliated to family and friends, and that older adults' affiliations are more characterised by places and place experience. They conclude that mobility does not always erode place identity but instead it should be examined within a developmental cycle that sees places become more important in later life and less so earlier in times when life-stage might contradict a permanent form of place identity. This conclusion is in accordance with recent research in autobiographical memory which shows that constructions of stability and continuity are particularly marked in older adults whereas adolescent and younger adults tend to produce narratives that feature themes relating to change (McLean, 2008). These studies have important implications for the understanding of place identity continuity and its utility. Again, it seems that at least some existing literature has hinted that a strictly deterministic, essentialist approach to place identity continuity might be a limited one (Speller & Twigger-Ross, 2009).

Issues of temporality and autobiography within the place identity literature have therefore signalled the significance of place-related continuity but in fact despite the wealth of theoretical critiques levelled at it, Proshanbky's original place-identity theory did also identify a key role of continuity. This is because Proshansky et al. (1983) sought not only to extend theoretical knowledge of the self to include reference to the physical environment, but also originally intended to challenge static conceptions of identity. They too therefore sought to examine the effects of changing environmental settings on identity by looking at cases of residential relocation. From this research they concluded that one of the overarching functions of place identity is the development of continuity of self and its role in integration of the self. They elaborated on this link between place and personal continuity with reference to the recognition function of place identity, suggesting that unchanged places serve to help the individual affirm a sense of continuity with their past, claiming that the "perceived

stability of place and space that emerges from such recognitions correspondingly validate the individual's belief in his or her own continuity over time" (1983, p.66).

This mirroring between the enduring physical space and continuing psychological place identity is put forward as a source of 'support and credence' for the individual's sense of personal identity (Proshansky et al., 1983). Indeed, the development of this place-related continuity is awarded such significance that the authors propose children should spend prolonged periods of childhood spent in one residential location to developing a stable place identity. Later studies, also identified continuity as an important process in operation in place identifications (e.g., Korpela, 1989) but because little specific empirical attention was given to Proshansky's statements, or any guidelines upon which one might expect these processes to occur, there has been little subsequent research on processes such as perceived continuity that has resulted directly from this theorising (Twigger-Ross et al., 2003).

Instead, the notion of place identity continuity has remained as a feature of the discussions in place identity literature, primarily in research looking at the link between places and well-being following forced relocation. Fullilove's (1996) root shock analogy discussed earlier, where she draws upon concepts of place identity and attachment as determinants of psychiatric health in displacement processes, is one such example of this. More recently, Carroll, Morbey, Balogh, and Araoz (2009) have provided qualitative evidence of the psychological processes that lead to post-traumatic stress disorder following relocation caused by severe flood damage. Interestingly, the authors make note of respondents' experiences of loss of ruptured bonds with their past and discontinuity with present and future resulting from losing their homes and treasured possessions. Attachment bonds and sense of security are identified as damaged through this process of disruption to home identity. They conclude that disasters not only affect physical health but attack bonds

of familiarity and attachment to the home as well as resulting in a “breaking with the past and discontinuity with present and future” (p.6).

As well as the application of theory to specific social problems such as displacement and the theoretical advancement offered by understanding them, authors in other domains such as planning and architecture have also been able to utilise insights from place identity to inform their work, particularly in relation to the link between place and continuity. For example, Yuen (2005) has suggested that particular places can perform self-regulatory functions because, “place identity can help to provide a sense of stability and continuity...to construct and preserve our identity.” (pp. 201-202), and that features of the environment such as old buildings are often said to provide people with a sense of history and permanence that situates them in time: past and future. Accounts such as these are clearly concurrent with Proshansky’s original theorising, as well as theorising from related domains of place research such as sense of place, rootedness, and place attachment theories. However, it is essential to note that they provide clear reference to the future dimension of continuity; a feature missing in the majority of existing empirical approaches. Not just in their explicit use of the future pole of continuity, but also with the idea that people connect their lives to places and the use of terms such as identity preservation.

For the most part, however, despite the valuable introduction of more located notions of identity and some exploration of the relationship between places and subjective continuity, the place identity construct has itself acted more as a starting point for research projects that tend to use their own ways of measuring the relationship between place and self (Pretty et al., 2003). Furthermore, many authors feel that the version of place identity they describe tends to be too fixed in contrast with the dynamic constructions of identity that appear in identity theories within related disciplines (Twigger-Ross et al., 2003). These issues, combined with the above-cited individualistic bias, has inevitably led to the calls for an integrative approach

to this literature and cross-fertilisation between the discipline and its close relative social psychology, a call introduced earlier in this thesis (Dixon & Durrheim, 2000; Stedman, 2002).

This integration is sure to not only benefit environmental psychology's place identity literature but also the social identity literature itself. That is because, as Dixon and Durrheim (2000) have suggested, whilst environmental psychology's notion of place identity captures the located dimensions of identity, this has often been missing from social psychological theory (with a few exceptions, e.g., Canter, 1977). This omission is theoretically significant not only because social identities are often inherently place-related, but also because of the compatibility of processes in relation to both types of identity dimension. If Proshansky and colleagues are correct then "what is true of self-identity is also generally true of its sub-structure, place-identity" (Proshansky et al., 1983, p. 60). Moreover, although there is some doubt over whether social or environmental psychology is best placed to approach the study of place identity, Dixon and Durrheim (2000) suggest that both approaches may be used integratively precisely because places are "socially constituted and constitutive of the social", and hence both inextricably linked (p.27). In light of these compatibilities, the social psychological literature on place warrants particular examination.

Social Psychological Identity Theories, Place, and Subjective Continuity

In Chapter One, it was suggested that the concept of identity can be conceptualised broadly as a definition of self and that much of the theorising in this area has its roots in the work of William James. As noted, James (1890/1950) described the spiritual, social, and material self, the latter included reference to the 'material self' in which is included specific reference to possessed places, such as the home. According to James, each of these aspects of self has equal ability to cause both positive and negative emotional responses in the

individual. Echoes of this multidimensional theory of self can be found in definitions of identity that recognise the role of personal characteristics and attributes, memberships in social categories and crucially, place belongings (e.g., Twigger-Ross et al., 2003). However, in comparison to other identity theories within social psychology, place identity has been relatively under-represented by research in the discipline. In contrast, other identity theories have been subjected to extensive empirical development. The idea that researchers in these domains may be well placed to rectify this disparity and begin to uncover the processes that link place to identity is, however, encouraged by the discovery that place has already been touched upon by two major identity theories within social psychology: Social Identity Theory and Identity Process Theory.

Social Identity Theory

As discussed, place identity theory has mainly attended to place in relation to the individual, leaving the social dimensions of place underexplored and the disciplines of social and environmental psychology largely independent (Dixon & Durrheim, 2000; Twigger-Ross et al., 2003). Research within the social identity tradition, however, has at its core an interest in the social elements of self and behaviour. Social Identity Theory (SIT) (Tajfel, 1978, 1979, 1981; Tajfel & Turner, 1986) focusses on the role of social category membership in intergroup phenomena such as stereotyping and prejudice, with reference to processes of social identification and comparison. According to SIT individuals are motivated to maintain positive self-esteem and seek positive evaluations for the groups to which they belong and that constitute their social identity. Cognitive phenomena leading to the accentuation of within-category similarities were used to help explain how identification with ingroup members and differentiation from outgroup members combined with strivings for positive group identity can lead to intergroup discrimination (Tajfel & Wilkes, 1963). Early studies

by Henri Tajfel, aimed at exploring the minimal conditions necessary for these kinds of intergroup processes, found that simple categorisation of the self as a group member, even when group membership was meaningless, was enough to stimulate ingroup favouritism. A wealth of empirical studies followed looking at a vast range of social phenomena. Subsequent research provided elaboration on the cognitive processes of categorisation and self-stereotyping which occur when an individual identifies with social groups or categories; this research formed the foundations of Self Categorisation Theory (SCT) (Turner, 1985; Turner et al., 1987) and together these two theories are often referred to as the social identity approach.

The social identity approach has proved a valuable addition to understanding behaviour in social terms. Social identity theorists have suggested that as the individual incorporates the (in)group in to the self, so are they then able to experience emotions and cognitions relating to the group (Tajel, 1981). Therefore, it is not inconceivable that the same processes apply to self-relevant places. However, although it has long been suggested that a social identity perspective may also illuminate behaviour in relation to the environment (e.g., Brown, 1986), there has been little work that has used this particular approach to advance place identity theory. Furthermore, as mentioned earlier, the social elements of place identities have not been of primary interest despite several calls for an approach of this nature (Lalli, 1992; Stedman, 2002). This is surprising considering many of the social identities studied in this domain are often intrinsically linked to spatial locations and research programs often share the same topics of interest. Notions of 'homeland', for example, connect to both place and national, ethnic, and cultural identity (Kakar, 1996), and both place and social identity incorporate psychological and physical boundaries of inclusion and exclusion (Dixon & Durrheim, 2004).

Despite this general lack of integration between the theoretical traditions, the literature reviewed earlier suggests that the application of social identity theory's procedural accounts represents perhaps the greatest potential avenue of disciplinary cross-fertilisation for promoting theoretical understanding of place identity processes. One such procedure might be the striving for positive self-evaluations through identity processes. Twigger-Ross et al., (2003) suggest that if place is taken as representative of social category then processes of specific place identifications might be interpreted as a means to achieve positive distinctiveness. That is, they suggest that, "the struggle for a positive social identity can be achieved through positive in-group *place* distinctiveness" (p. 225). Indeed, research in architectural science has suggested that people tend to prefer places with positive features that enhance self-esteem (Hauge, 2007) and environmental psychology has shown place attachment levels to be indicative of the valence of attitudes towards place (Lalli, 1992).

This drive to maintain a positive self-image can also be evidenced in patterns of residency and mobility such that place identities may be adopted, defended, adapted or disregarded in a similar way to social groups (Twigger-Ross et al., 2003). Twigger and Breakwell (1994) looked at coping strategies displayed after a hypothetical threat to the environment. In particular, they examined how hypothetical group threats to local area like industrial dumping affected tendencies towards social change or mobility strategies. Crucially in terms of continuity, they found that people who were highly attached were more likely to opt for a social change strategy that would perpetuate the link between them and that cherished place whereas those less attached were more likely to prefer moving location. This study suggested that identity processes analogous to responses to social identity threat might be played out in response to threats to place, and the authors proposed that identification with place and social group may then only differ in terms of identification type.

Experimental substantiation of this proposed link was later provided in Bonaiuto, Breakwell, and Cano's (1996) social psychological study of local and national identification and environmental evaluation. The authors looked at the impact of social context and identity processes on perceptions of beach pollution, by creating ostensible EU evaluations of local beach pollution to act as a potential threat to place identity. They expected to see similar defensive responses as those evinced in situations of social identity threat and predicted that English participants would make positive discriminations when evaluating local and national beaches in England such that their responses would be guided by ingroup preferences and not actual pollution or the assessment made by the fake inspectors. The result showed this to be the case, demonstrating processes akin to ingroup favouritism. Moreover, lower levels of perceived pollution, and the denial of pollution, were predicted by both national identity and local town (place) identity showing defensive behaviour typical in social identity paradigms but in relation to place identity. The authors conclude that there are complex identity processes involved in relationships with place which can determine evaluations of the environment more than demographics or levels of environmental concern (Bonaiuto et al., 1996). These research programs have provided some support for the correspondence of psychological processes involved in relation to both social and place identity, specifically in relation to the provision of positive self-evaluation. However studies such as these are limited in number and social psychological analyses of these processes are not typically motivated by a social identity analysis (e.g., Twigger-Ross & Uzzell, 1996).

One other key dimension of social psychological analysis that has indicated social and place identity types may correspond is work exploring to the role of context. A key feature of social identity approaches is the idea that different social contexts can make particular social identities salient and as such, behaviour resulting from social categorisation processes is context dependent. However, Condor (1996) has suggested research in this area has been

based upon a limited definition of social context by focussing on people as the primary source of contextual definition. This definition has meant that the role of place (and time) as social context has been underappreciated. However, as has already been noted, it is reasonable to suggest that places may act as contexts and that place identities might be context-dependent, in a similar manner to social identifications. This compatibility is primarily evident in work that has noted that just as individuals can identify with social groups that have varying levels of size and abstraction, so too place identity involves different levels of socio-spatial identification that carry with them their own set of common features (Cuba & Hummon, 1993).

In one of the few studies of its kind, Levine and Thompson (2004) seized upon this idea of adding a spatial dimension to the study of helping behaviour by experimentally manipulating self-categorisation processes. In their study they use places as representative features of social identity to determine when individuals will opt to help countries experiencing natural disaster. They reasoned that manipulating social identity may bring about changes in sociospatial scale that will affect the likelihood of participants indicating their willingness to give aid to other countries. Their results showed that British participants were more willing to give aid to Europe compared with South America when their European identity was made salient, whereas when British identity was made salient they were more likely to give to Britain than Europe. They concluded that when the place is consonant with social identity, people are more willing to intervene financially and help ingroup members. They also showed this was not due to geographical location or distance from home because if participants' European identity had not been made salient then they were not any more likely to help there than in South America.

One of the main conclusions to draw from this study is that places can be represented as ingroup or outgroup by their connection to social identity. However, it seems possible that these behaviours might also be due to the place itself either being part of self or not, through processes of *place* identification. The authors themselves even warn, “Investigators do not yet know how much of the intervention can be explained by relations to place itself or how much can be explained by relations to the people in those places” (Levine & Thompson, 2004, p.242). They relate this difficulty to the tendency in social identity research mentioned earlier to treat people as context and suggest the unravelling of effects from different kinds of contexts is a valuable future research endeavour.

As well as ascertaining the application of social identity processes to place identity, a small number of studies within social psychology have looked at the interplay between group identity and place-related behaviour. In particular, several studies have shown a link between national identity and spatial behaviour. In a qualitative study, Hopkins, Reicher, and Harrison, (2006) found that people reported being less likely to relocate to places which are not concordant with their national identity. In another study, the same authors (Reicher, Hopkins, & Harrison, 2006), also used an experimental approach to also demonstrate the link between social identity and place, showing that national identity salience increased the likelihood of preference for ingroup over outgroup places as potential employment locations. Interestingly this was mediated by a sense of fitting in or being at home, which as literature reviewed earlier has shown is often taken as a proxy for place identity. These studies suggest that not only do collective identity processes affect the evaluation of places but that this also has the potential to impact upon significant life choices.

A recent publication, which spans social and environmental psychology, has provided some further evidence of the link between collective identity and evaluations of place.

Lewicka (2008) looked at the nature of participants' collective memories of place to identify ethnic biases of the residents of two cities in Poland that have both undergone significant change in terms of their population and national character. Evidence of these ethnic biases in memory content, which help express the ownership of current residents, was found for both groups, again suggesting the use of place in positive evaluations of self (cf. Bonaiuto, et al., 1996; Twigger-Ross et al., 2003). However, they were predicted by different factors. In one group, memory biases were predicted by participants' levels of national identification, but in the second, where place identity is lower, by demographics such as young age and modern accommodation. The key difference is in the former, the city is seen as symbolic of national identity and in the latter, the place is disconnected from identity. An important conclusion drawn from this study is that, as in social identity research, when place identity is salient, it becomes indicative of behaviour and traditional determinants such as socio-economic status, age or sex, lose their explanatory power in favour of identity-based predictors; this is also evident Bonaiuto et al.'s beach pollution study. One interesting distinction was also evident: in Lviv, the city characterised by high place identity, the content of collective memory was presented positively by using references to historically significant national characters. In contrast, in Wroclaw, where place identity was lower, positive figures were typically contemporary in nature. This finding, again, hints at the importance of temporality in place and social identifications.

There are very few mentions of place identity continuity itself within the social identity research literature. However, the work of Devine-Wright and Lyons (1997), exploring the collective dimensions of people-place relationships, has highlighted how these relationships can provide a sense of self-esteem and identity continuity. In their study, Irish participants from different political groups were asked to rate the significance of historically symbolic Irish sites. The study showed that the types of places deemed historically

significant were those that represented the particular group participants belonged to and helped construct a positive group identity with a sense of historical continuity. As well as supporting current claims that places can constitute a viable source of identity continuity, works such as these also support the compatibility between place and social identity processes in as much as recent social identity literature has demonstrated the importance of perceived collective continuity provided by national, regional and family group identification (Sani, Bowe, Herrera, Manna, Cossa, Miao, et al., 2007; Sani, Bowe, & Herrera, 2008; Herrera, Sani, & Bowe, 2011).

One important question still remains despite these empirical indicators of similarity. That is, it is not always clear whether place is another equivalent identity element, therefore operating by similar rules, or whether place is merely a symbol that is representative of social identity, and in that sense just part of the social identity. It seems possible in Levine and Thompson's study for example, that the former could be the case as participants could be acting in terms of a place identification. However, clearly in other studies, such as that of Hopkins et al. (2006) or Devine-Wright and Lyons (1997), place seems more symbolic of social identity. Researchers in the both environmental and social psychology have varying opinions on this dilemma. Twigger-Ross, et al. (2003), for example, suggest that social identity theory may be extended towards places and that social identities have place-related implications. However, it seems this statement involves a definition of place *as* social group. This is evident in their statement that place, "can be considered as part of the self-concept because it is treated according to similar principles operating for other aspects of an individual's *social* identity" (Twigger-Ross et al., 2003, emphasis added),

Nonetheless, other researchers in the social identity tradition have recognised that place and social identity can be treated as distinct (Moser & Uzzell, 2003). Whilst there is no doubt that place can be a socially-defined entity, the concerns with this position are two-fold:

firstly, this conception of the place as social group leaves out the role of place as a feature of personal identity, memory, and narrative; secondly, it seems to neglect the importance of the physicality of places. This neglect is important because the place identity literature suggests there is a perceptual mirroring between physical places and people that reflects upon and validates the self (Proshansky et al., 1983). Whilst the first issue may be justifiable from a social identity perspective that considers the distinction between personal and social identity a problematic dichotomy (Jetten & Postmes, 2006), the second issue may be harder to resolve from the perspective of environmental psychologists. Graumann (1983) states for example that place identity is a complex construct that involves many dimensions and crucially that can refer to different environmental *and* social levels. On the few occasions when the social elements are analysed they are labelled to indicate this distinction, for instance as ‘place-related social identity’ by Uzzell, Pol, and Badenas (2002) and social and physical elements are sometimes analysed separately (e.g., Hidalgo & Hernandez, 2001).

Twigger-Ross et al. (2003) suggest that the distinctions made between place identity and social identity may simply be due to differential emphasis between the group in some cases and the place in others, and propose that whilst the two are conceivably inseparable, the issue of extent of transferability of process should be settled empirically. This task therefore represents a potential avenue to advance both social and environmental psychological theory that makes up one of the key secondary aims of this thesis. However, Twigger-Ross et al., (2003), and others (e.g., Moser & Uzzell, 2003), have suggested there is no need for two distinct identity theories as a framework exists upon which both can be easily applied: Breakwell’s Identity Process Model.

The Identity Process Model

The second of the social psychological approaches including reference to what might be considered place identity, is Breakwell's Identity Process Theory (IPT; Breakwell, 1986, 1993, 1994). The model was developed to extend the limits of social identity theory such that identity processes beyond those driven by striving for positivity could be explored (Breakwell, 1993). This model treats identity as a dynamic and changeable product of both the human capacity for memory, consciousness, and organised construal, and its interactions with both physical and societal dimensions of the social context. According to IPT, identity is defined by two distinct planes: the content plane and the evaluative plane. These are governed by psychological processes and are expressed by thought, affect, and action whilst being subject to constant change and adaptation. The individual, in this account, is considered self-aware and has a monitoring role in the status and maintenance of identity, hence identity is not viewed deterministically but instead is created via agentic processes.

In contrast to the social identity approach, this model looks at *both* personal and social identity simultaneously as equivalent components of identity 'content', and treats the distinction between them as purely a temporal artefact. Whilst also recognising the role of salience, the theory argues the content of identity is also influenced by the variable centrality and hierarchy of identity elements. These elements of identity content can include social characteristics like group memberships and roles, as well as more individually-based characteristics. Furthermore, each of these identity elements have a value attached to them determined by relationships between the individual and current social value systems. This value aspect is important because the structure of identity is controlled by dual processes of evaluation and accommodation-assimilation (a two-pronged process describing memory-based incorporation of new information into identity and the adjustment of identity structure).

Both processes facilitate the development, selection, and maintenance of desirable and useful identity elements in the changing social environment and are governed more by self-interest than by accuracy. These processes operate in accordance with ‘identity principles’ that relate to the fulfilment of certain psychological needs. The principles are culturally variable but in western cultures they relate to motives for self-esteem, distinctiveness, self-efficacy and, crucially, continuity (Breakwell, 1993).

As well as being culturally variable, the primacy of each specific principle varies across time and situation because identity elements are assimilated in accordance with context and social influence processes (Breakwell, 1994; Twigger-Ross et al., 2003). Recently, Vignoles, Regalia, Manzi, Golledge, and Scabini (2006) used this theoretical approach to demonstrate how satisfaction of these multiple identity motives leads to the perceived centrality of identity elements. In these studies, the authors extended Breakwell’s model suggesting that a sense of belonging and meaning – in addition to self-esteem, distinctiveness, efficacy and continuity – are key psychological needs that guide identity maintenance, and construction. It follows from this that if a place satisfies motives for continuity, then it will become increasingly central to identity. This idea corresponds precisely with the theories of human geography and other disciplines that suggest that people become particularly concerned with and attached to those places that can provide a sense of self-continuity. Interestingly, in a later study the authors also use a survey data to connect these identity principles to views of desired future selves (Vignoles, Manzi, Regalia, Jemmolo, & Scabini, 2008), adding both a temporal dimension to this theoretical framework and indicating the connection between identity principles such as continuity and feelings about the future.

According to IPT researchers, places can be regarded as important identity elements that are socially symbolic. They are meaningful in two specific ways. Firstly, they may represent personal memories through associations with particular interactions or events making them a significant part of an individual's personal history. Secondly, they may also represent social memories meaning they can become enmeshed in inter-group relations and representative of social status (cf. Lewicka's 2008 Polish study on ethnic biases). Just like other identity elements in IPT, places are subject to the need to satisfy the core identity principles and as such, their meaning is open to negotiation and reinterpretation (Twigger-Ross et al., 2003). Ultimately, this means that if a place cannot satisfy these motives then its inclusion in the individual's identity will be unlikely.

Twigger-Ross et al., (2003) suggest that in light of this model's explanation of place identity processes within the remit of general identity processes there is no need to propose a specific place identity theory. However, they suggest that in light of its role as a pervasive identity element, it should be recognised within social psychological theorising on identity. To date it is from within this model that social psychology has given most of its attention to place and identity, and that the most well-developed arguments on place, identity, and continuity have emerged.

The earliest work from these origins was put forward in a conference paper by Glynnis Breakwell in 1996. Here she discussed place relationships and the role of new place relationships in identity threat suggesting that that places are identity elements "subject to the pressure to maintain self-esteem, self-efficacy, continuity and distinctiveness" (p. 9). She outlines that being immersed in new places can constitute identity threat due to the challenges brought about by feelings of unfamiliarity, new demands and the invalidation of previous place relationships. According to IPT, situations of threat are viewed in the model as the juxtaposition of assimilation-accommodation processes with the demands of satisfying

identity principles. In these situations it is thought that the individual will be motivated to reinstate sensations associated with the principle in question and as such will adopt appropriate coping strategies. In adapting to place change, continuity is clearly challenged and so the individual will act to recover a sense of place-related continuity.

These situations may also result in either the attenuation or accentuation of the support provided by old and new places respectively, making them less or more salient parts of the individual's identity. In some situations engagement with a new place may result in a sense of complete dislocation from the old place, such that it loses its relevance and may then no longer be triggered as part of the individual's identity at that time. This line of reasoning is consonant with the idea of identity salience found in the social identity literature. Another concordant element of IPT's theorising on place is the nesting of places as different identity elements, such that one may identify with home, community, and nation. According to the theory these levels of identity tend to be socially rather than geographically defined and may be used differentially depending on context and threat. It seems therefore that the identity process model can offer a framework that is not only complimentary with social identity approaches, but that also concurs with place identity and place attachment literature.

By far the most significant strength of IPT for the study of place identity continuity though, is its inclusion of identity principles, specifically the continuity principle. This dimension means they go beyond place as context and towards a model that includes "place as an integral part of the identity process" (Speller, Lyons, & Twigger-Ross, 2002, p. 5). In a landmark IPT and place study, Twigger-Ross and Uzzell (1996), conducted an interview study of residents' accounts of their local environment in London's Docklands, in accordance with Breakwell's identity principles. They found evidence of place-related self-esteem, distinctiveness, self-efficacy, and continuity in residents' accounts, and that these effects were significantly more pronounced in those participants who expressed stronger place

attachment. Importantly, these authors characterised place identity continuity in two specific ways. The first type of continuity constituted what they termed ‘congruent continuity’, emphasising the way that associations with the residency depended on how *congruent* the place was seen to be with the individual’s identity. That is, there was evidence that different places were used to maintain a stable, continuous definition of self, contingent upon the level of congruency between the nature of the place and their conceptions of their identity.

In keeping with more temporally defined notions of continuity, a second type of continuity termed ‘referent continuity’ was also evident in the interviews. This was expressed through the use of place as a reference point for their identity such that their residential locations afforded them a sense of continuity with their past. The place therefore embodies memory and fixes the individual in the past, in a way consonant with so many of the accounts discussed above from various disciplines within and outwith psychological theorising. However, the authors make no reference to the afore-mentioned sense of permanence, ongoing narrative, or more precisely, continuity of self into the future that is also implicated in the cross-disciplinary definitions of self.

Knez (2005) subsequently provided a broad replication of Twigger-Ross and Uzzell’s results using a quantitative design. He showed increased place attachment and the congruency of ‘city-person’ identity predicted satisfaction of the identity principles for residents of Gothenburg, Sweden, again including both congruent and referent continuity. Importantly, his model showed that it is increased residential time that first leads to place attachment and then to satisfaction of identity principles. This finding supports the earlier theoretical positions of environmental psychology and suggests that the processes of interaction and the building of memories and narratives across time have a fundamental role in instigating place identity processes.

The identity process model has been continually productive in its examination of place identity, although the literature has for the most part focussed on identity processes in the reaction to place change, specifically relocation. Gerda Speller and colleagues have led this research centred on the forced relocation of a traditional Derbyshire mining community in the 1980s to a replacement modern housing development. The authors used qualitative analyses to find evidence of change in salience and satisfaction of each identity principle both before and after the forced community relocation (Speller, 2000; Speller, Lyons, & Twigger-Ross, 2002; Speller & Twigger-Ross, 2009). Results showed that collective self-esteem and distinctiveness were replaced by more individually defined self-esteem and distinctiveness over the course of the move due to the changing nature of the place from an interacting, egalitarian community to an individualistic, materialistic housing scheme.

In regards to the continuity principle, Speller and colleagues also found that the new place was not congruent with the old location leading to a violation of place-related congruent continuity, which led to a sense of loss of continuity at the collective, community level. For some residents this led to a seeking of individual self-esteem and distinctiveness, but for others the loss of this sense of continuity was seen to cause substantial distress, signifying the importance of this place-related continuity. Interestingly, and in accordance with place attachment work (e.g., Fried, 1963), the role of the old site in providing continuity was not always apparent until this continuity principle was challenged in the context of place loss (Speller, et al., 2002). Although recent work suggests relocations are not always experienced negatively, particularly if a degree of choice and control over changes in place identity are involved (e.g., Bernardo & Palma, 2005), relocation generally impinges on subjective connections with the past. These processes are related to the provision of referent continuity, and to the role of places as fixing aids and embodiments of memory (cf. Korpela, 1989). Alternative studies using the IPT framework have supported this idea, for example,

Lyons (1996) reported that identity principles, like the need for continuity, guide the construction of social memories. This work also compliments approaches from social and political psychology, which have looked at the strategic use of social memories to create a desired sense of national collective continuity (e.g., Reicher, 2008).

The identity process approach has therefore been instructive in revealing the processes of place identity and has redefined the construct of place identity as one characterised by dynamic change and adaptation. Moreover, it has paid specific attention to the importance of a sense of place identity continuity. By examination of these processes and the conditions under which they become more or less central to identity maintenance, identity process theory has gained significant explanatory power in relation to many kinds of identity relevant behaviours, including those connected with places. However, where it claims to look at outcomes of identity processes, such as thought and affect, there is little empirical evidence of the outcomes of identity beyond satisfaction of identity principles. In addition, although context is said to influence identity in this account (Breakwell, 1992, 1994), there is less evidence to support the actual impact of context in comparison to the elaborate paradigms of social identity research.

However, for the purposes of exploring subjective self-continuity, the most serious omission in the identity process literature is the conceptualisation of place-related continuity as only referent continuity – with the past – and the need to maintain continuing congruency of place identity. What is missing is any reference, beyond a passing comment, toward future self continuity. This is the case for all but one study (Droseltis & Vignoles, 2010), which looks simply at general continuity using only one item, and does not delineate between continuity types. This solely past-focussed approach is a significant limitation because it is not in line with the work of researchers looking at the psychological significance of perceived

continuity across time (e.g., Bluck & Alea, 2008; Burris & Rempel, 2008; Chandler & Proulx, 2008, Landau, Greenberg, & Solomon, 2008; Sani et al., 2008), or with the understanding of the concept of place identity continuity in human geography and environmental psychology, discussed earlier. In this respect, the IPT model may provide a useful approach to look at some aspects of place identity and subjective continuity but it requires development in order to fully appreciate the significance and structure of place identity continuity and the potential functions of it and place identity in general.

Discursive Approaches to Place and Continuity

One important area of psychological theory also acknowledging the link between place and identities emanates from a more discursive, constructionist tradition that focussed on how these relationships are dynamically constructed in participants' talk and actions (e.g., Dixon & Durrheim, 2000). Transactional approaches examining interaction have often been used in environmental psychological research to capture the dynamic nature of person-in-place relations. They prove particularly useful as empirical designs do not lend themselves as well to examination of particular interactions between person and location (Saegert & Winkel, 1990). Consequently, transactional approaches have problematised empirical approaches commonly characterised by a desire for generality and have brought to the fore issues of reliability and the influence of the researcher, both in research design and in the testing situation. These approaches will be described only in brief here, as they will be explored in full in Chapter Four, which focusses on methodology and these issues of theoretical approach.

Stokowski (2002) notes that as well as being dynamic socially-constituted contexts, the discourse produced on the topic of place also embodies overt and covert social practices and place-making behaviours that may conceal ideological, political, and power processes.

In acknowledgement of this discursive dimension, she urges that sense of place is a social construction, in this case in relation to public leisure sites. She suggest that places should not be viewed in a static sense but should be understood as permanently in creation and subject to manipulation for sought after personal, social and political outcomes.

Taylor (2003, 2005, 2010) also adopts a discourse analytic approach to look at the way place is used as part of a set of narrative discursive resources employed by interviewees to construct and present a version of self. Taylor focusses on normative narratives of identity and place and how they can be drawn upon in women's identity work to balance normative ideals of rootedness with the mobility and residential shifts that are often 'way-markers' in their life stories. Taylor treats narratives as both construction and resource, elaborating on how individuals can draw upon situated accounts of family and personal history to make legitimate claims of belonging. She suggests participants can respond to dominant cultural discourses such as the 'born and bred narrative' in this way. In doing so she also suggests that place identities are frequently represented in terms of continuity, for example in terms of connections with a chain of ancestors and future family generations, specifically because they endorse stewardship over the land. Interestingly, she also suggests that constructions of continuity between the past and the present also help women to construct a sense of projected future identity: an "extension of continuity from now into the future" (Taylor, 2010, p. 74).

However, she also proposes that this normative ideal is increasingly difficult to achieve in light of societal increases in mobility and multiple residencies, drawing upon sociological accounts of 'modernity' (Giddens, 1991). She therefore explores how women's accounts of their place identities can include notions of choice and opportunity to effectively deal with these contextual constraints. By doing so, they have the opportunity to redefine place identity as characterised by choice as well as rooted historical connection. She aligns these accounts with modern sociological approaches to mobility that suggest people

increasingly inhabit the world in different ways in western societies where moving is part of a story of maturation and success (van Meijl, 2010), and where dichotomies between 'rooted belonging' and 'rootless mobility' are over-simplistic (Ahmed, Castañeda, Fortier, & Sheller (2003).

In light of these strategic uses of identity construction, social psychologists have explored the use of these kinds of place identity discourses to promote particular relationships and behaviours at an intergroup level. This has often centred on the notion of inclusion and exclusion and explored the methods by which places help to define those who do not belong, and are deemed 'outsiders', in contrast with those who fit and are accepted. Behavioural outcomes such as segregation have provided elaborate evidence of these processes in action (see Dixon, 2001; Dixon & Durrheim, 2004; Dixon, Foster, Durrheim, & Wilbraham, 1994; Dixon, Reicher, & Foster, 1997). Similarly, these versions of identity may be used to promote outmoded negative behaviours that nonetheless maintain a historical sense of place identity (Wallwork & Dixon, 2004). These ideas have found some additional support outside of psychology in geographical studies of the political construction of landscape boundaries aimed at manipulating a sense of what belongs and what does not (Trudeau, 2006).

As well as exposing the ways that manipulation of the shared societal views about the value of place and identity continuity can be used to achieve certain ends, discursive approaches, like Taylor's (2010), can also tell us something about the methods people use to manage this call for place-related continuity. For example, sociologists have utilised this approach to look at the accounts of people who consider themselves as life-long travellers. This research has revealed that these individuals often negotiate their mobility with reference to the idea of the 'global abode', such that they present themselves as world citizens who can feel at home *anywhere* in the world thereby challenging the notion of the dislocated 21st Century mobile individual (Germann Molz, 2008).

These studies have made valuable contributions regarding the ways continuity might be managed, and have spoken to the motivation behind maintaining a sense of place identity continuity to some degree, particularly in political terms. Nonetheless, adopting this approach means accepting the limitations inherent in looking at only the content of discourses, namely the choice to turn away from and address issues of phenomenology. This approach therefore leaves unexplored psychological processes such as sense of coherence, attachment, emotion, stability, and crucially sense of continuity, which have been linked to place identity by so many theorists and researchers. The significance of this methodological decision and potential solutions to it will be explored more fully in Chapter Four but it is pertinent to note that the exclusion of experience from social psychological analysis is therefore unsuitable for satisfaction of the current aims of exploring *perceptions* of place identity continuity. Nonetheless, it is essential to be cognisant of these discursive processes of construction and politicisation in order to appreciate the complexity of the relationship between person, or people, and place, and the way these relations may be used strategically to fulfil personal and political agendas, and to mediate social issues, power relations, and prejudices. Indeed, this has been laid down as crucial task for political and social psychology (Hopkins & Dixon, 2006).

Implications of the Proposed Research

As well as developing the existing psychological research on perceived identity continuity, the further implications of studying place identity continuity appear to be numerous on the basis of the literature reviewed above. First, it is important to understand the central features of place identity due to their potential psychological consequences in relation to health. A number of authors from different disciplines have stressed the importance of place identity for human well-being and self-regulation, (e.g., Lowenthal,

1985; Lynch, 1972; Proshansky et al., 1983) and there has even been some links made between a reduction in various physical symptoms of ill health and reduced stress when visiting favourite places (Korpela & Ylen, 2007). As perceived continuity has been found to be linked to positive well-being in social groups, it is essential to understand the full nature of these continuity-related processes in place identity in order to promote practices that can protect this aspect of mental health.

In addition, the uncovering of the processes involved in perceptions of places can begin to afford an understanding of why people can become so emotionally dependent on their home, community, and national territories. This is especially relevant as despite the nuances of modern relationships with place, community ties can remain dysfunctionally strong in certain intergroup contexts such that they have been labelled as potential “pathologies of community attachment” (Fried, 2000, p. 193). Furthermore, whilst these types of studies will develop understandings of the phenomenon of place identity they also seek to provide opportunity for further cross-disciplinary knowledge sharing with environmental psychology and may potentially be of relevance to other disciplines. For instance, by investigating the significance of maintaining perceptually continual place identities for well-being, the proposed research can inform disciplines as diverse as gerontology. In doing so, it can complement and extend existing research that highlights the importance of feeling ‘at home’ for determining the consequences of moving elderly individuals into residential care (e.g., Mitty & Flores, 2008).

The findings of this research may also be applied to various parts of society. For example, it may be applicable to the study of emotional responses to migration for small groups such as families. An understanding of how place-related continuity is maintained and how it interacts with other complex identity processes might help address concerns relating to why some families manage these challenges more effectively than others do (Allen, 2008).

However, this research topic is equally applicable to the study of larger groups such as ethnic city communities who are often most subject to forced relocations (Fullilove, 2001). In the wider political arena, this research could impart valuable insights into the determinants of the psychological health of immigrants, who often experience a rupture in place identity continuity, and so may aid in promoting successful acculturation programmes that include acknowledgement of the need to re-establish a sense of place-based self continuity. This research may also facilitate a deeper appreciation of the gravity of world events such as the Asian Tsunami, Pakistani earthquake, Hurricane Katrina in the USA, and in the present political climate in the devastating conflict in the Democratic Republic of Congo, each of which has resulted in thousands of people losing their homes. It is politically essential to understand these processes that link people to place as they can have a profound impact on people's behaviour, even leading to lower risk perceptions and refusal to leave war-torn and dangerous environments (Billig, 2006), as well as for the purposes of promoting a more sophisticated understanding of the place-related reasons for war (Hopkins & Dixon, 2006).

Conclusions

It is clear from the breadth of research discussed above that place is far more than the background for action, and that instead it is a highly symbolic part of the history and framework of human identities. Furthermore, it can lead to a sense of subjective continuity of self; a perception that has been shown to be crucial in the development and maintenance of self, as well as for performing key psychological functions at both individual and collective levels. It is therefore essential that psychology, and the political debates informed by the subject, be familiar with the deep psychological connections between people and place to

gain a full understanding of the processes at work in the relationships between people and the places that they consider part of the ongoing fabric of their identity.

To achieve this understanding it is necessary to step beyond this vast array of largely qualitative research. This is because despite its concurrence on many issues of place-related emotion, perception, and identity, the dominant literature hails from disparate and frequently inconsistent research disciplines and often involves limited conceptions of the significance of place identity continuity. What is needed is the creation of a coherent theory of self continuity bringing together qualitative and quantitative methodologies drawn from a combined background of Place Identity Theory, Social Identity Theory, and Identity Process Theory to provide a full exposition of perceived continuity and its functions. Moreover, this conception of continuity should be characterised by a connection across time from past, through present, *and* to future. The remainder of this thesis will therefore be focussed on the provision of evidence that this crucial sense of self-continuity can be obtained not just through social products and interactions but also from the physical environments that we call our home.

CHAPTER FOUR

Methodological Approaches

Introduction

The previous two chapters have provided reviews of the existing literature connecting the key concepts of place, identity, and continuity. This chapter is concerned with introducing the chosen methodologies of the studies included in this thesis research program. Therefore, the initial task of this chapter will be to provide a critical methodological analysis of the existing empirical studies reviewed earlier, specifically those that relate directly to the psychological connection between places, identity, and subjective continuity. The main purpose of this critical review is to make an argument for the methods that have been chosen and how these methods will help satisfy the aims of the thesis.

Chapter Two outlined contributions from non-psychological disciplines, primarily anthropology, sociology, and human geography, to the area. Although, their exploration of these topics was largely observational and conceptual, one clear message emerged: emotional connections and feelings of identification with places is a pervasive feature of human existence. This message was evident in each account, whether place-person relationships were conceptualised as topophilia, sense of place, rootedness, place dependence, or autobiographical insideness. More importantly, many of these literatures highlighted the connections between places, human identity, and perceptions of continuity.

A number of commentators, primarily anthropologists, and sociologists, have translated these theoretical ideas into empirical studies. These studies, primarily qualitative in terms of methodology, have revealed the significance of the temporal aspects of places by uncovering the roles of variables such as length of residency, biography, history, and

accumulated memory in place relationships. They have also highlighted the potentially consolidative relationships between the enduring physicality of places and perceived continuity of identity, both personally and in a socio-cultural sense. In addition, they have also hinted at the human need to maintain place relationships by exploring the impact of place discontinuity and disruption, and the pervasive desire to 'preserve'. Together this series of observations provide support for current propositions regarding the significance of place identity continuity defined in terms of both past, present, and future continuity.

Chapter Three also provided a thorough literature review of the interconnection between place, identity, and continuity, but with a focus on the psychological literature. A large part of this literature was concerned with issues of place attachment, with occasional insights from psychiatry. Together these literatures again emphasised the human propensity for emotional reactions to places, particularly homes and neighbourhoods, and especially in times of place change. This research has successfully helped identify the link between places and continuity; however the place attachment literature has been highly criticised due to its lack of practical theoretical framework. This persists despite claims about the developmental significance of place attachments and calls to integrate place attachment with John Bowlby's (1969) Attachment Theory (e.g., Giuliani, 2003).

The chapter then traced the trajectory of place identity conceptualisations from within environmental psychology, specifically in terms of Proshansky's Place-Identity Theory (Proshansky, 1978, Proshansky et al., 1983). It was argued that although Proshansky's own conceptualisations of 'place-identity' included an environmental past and a sense of place-related continuity, this theory, similarly to place attachment theories, has also suffered from a lack of procedural accounts rendering empirical testing difficult (Twigger-Ross et al., 2003). This lack of understanding about the mechanics of place-identity resulted in multitude of place identity measures and accounts unable to converge upon a singular place identity

definition. It was, however, noted that this landmark theory constituted the first psychological espousal of place identity and provided a base from which to develop a full integrated account of place identifications and their role in perceptions of identity continuity. Moreover, it was noted that certain features of the place identity literature are concurrent with the procedural accounts offered in the social identity tradition, particularly Self-categorisation Theory (Turner et al., 1987). This observation suggested that place identity and social identity theories may be describing similar components of identity.

The social psychological accounts described in this chapter that including some relevant representations of place were primarily from one of two main traditions: the social identity tradition (Tajfel & Turner, 1981; Turner et al., 1987) and the identity process tradition (Breakwell, 1986, 1992, 1996). Notably, whilst the former included recognition of the connections between place and identity, especially the symbolic nature of places for identity, place was typically taken as either a proxy for social identity or a feature of it. It was therefore not treated as an independent component of identity. In spite of this, some of these studies are methodologically relevant and worthy of further critical analysis.

Studies housed within the identity process tradition have provided some direct accounts of place identity processes and have explicitly included a sense of continuity as a driving force in identity construction and maintenance. These studies, and specifically the utility of their methodologies, will therefore be analysed in full below. By drawing upon methodologies from each of these theoretical frameworks it is hoped that this thesis can help respond to the calls for cross-fertilisation between the disciplines of environmental psychology and social psychology (Dixon & Durrheim, 2004). There have been some initial steps towards that goal taken in the writings of several authors. Each has invited future research pulling together either two or all three of these main theoretical approaches (e.g., Hauge, 2007; Korpela, 1989; Twigger-Ross et al., 2003; Stedman, 2002). Others have

suggested that this integration will cultivate conceptual clarity, affording an understanding of behaviour resulting from these particular types of identifications (Devine-Wright & Clayton, 2010). This theoretical integration is an important task within this thesis and it provides a basis from which to achieve the primary aim of this thesis: to provide an account of places as sources of place identity continuity.

With this context in mind, the current chapter will focus on three main tasks: i) a critical analysis of the existing psychological studies that have been published in respect to the issues central to this thesis, with a specific focus on the methodologies used and the validity and comprehensiveness of their conclusions; ii) a critical discussion of the quantitative and qualitative methodological approaches needed to fulfil the aims of the present thesis, with a specific focus on the utility of their combination in research programmes; and iii) a description of the approaches employed in each of the prospective studies included in this thesis.

Critical Analysis of Place, Identity, and Continuity Studies

Place Identity Methods

It has been clearly noted that although the place identity literature initiated valuable moves towards a located notion of identity, the discipline has been subject to methodological critique. However, particular environmental psychologists working in this domain have made some empirical progress and as such offer potential methods for use. The majority of methods used in this area are qualitative, therefore these methods will be examined first, with discussion of quantitative approaches considered next.

Chow and Healey's (2008) study of first year undergraduate students' experiences of moving to a new residential location to attend university in England provides a good example

of a qualitative approach to the study of place identity that considers issues of continuity. The authors employed an interview-based longitudinal design with ten students to explore the challenges associated with place identity and attachment at two time points across the transition period (five months apart). They identified a loss of place identity and subsequent sense of continuity as a particular challenge limiting students' ability to identify with their new place as a self-relevant home. As discussed in Chapter Three, focussing on place change is an effective means to access place identity cognitions that are often hard to articulate, as it is often via a sudden sense of dislocation that place identity is most reflected upon (Brown & Perkins, 1992). This approach also allows access to feelings of *discontinuity* such as those expressed in existing interview studies of forced relocation or sudden place change (e.g., Carroll et al., 2009; Fried, 1963; Fullilove, 1996, 2002). However, a focus on place identity change may limit an understanding of place relationships in everyday situations that lack an element of significant change, although it should also be noted that lack of change and continuity are not synonymous.

Interviewees in Chow and Healy's (2008) study revealed they experienced their residential shift as a change in self, thus challenging overall self-continuity. Some evaluated this positively as a marker of personal growth, but this positivity was jeopardised by a loss of perceived continuity, familiarity, and security. Those experiencing the move as problematic reported it as, "arousing a conscious discontinuity" (p. 367). They sought to resolve this and reinstate continuity by seeking to retain connections with their place of origin, therefore hinting at the significance of future-oriented, projected place identifications. Despite this, the study was limited in terms of its exposition of continuity because although the authors quote Speller et al.'s (2002, p. 43) theoretical definition involving, "not the complete absence of change but some connection between the past, the present *and the future* within identity"

(italics added), they only conceptualise this continuity with a connection to the past referring to Twigger-Ross and Uzzell's (2006) place referent continuity.

This means Chow and Healy's study highlights the role of place in providing a symbolic link to the past only. However, as the context of the study involves transition from a place that symbolised students' past identity, the unidirectional orientation is appropriate, and is reflected in the discussions of memory and past experience featured in their analyses. The study does include some acknowledgment of a new sense of place as dependent on identity congruency, but the specific focus on change of residency may limit exploration of perceived continuity as oriented towards the future. Therefore, this approach of looking at identity change over times of specific mobility was not employed in the current research program, as it appeared to be particularly past focussed and therefore less suitable for revealing the full structure of place identity continuity. Instead, the studies conducted needed to provide a means to look at continuity in relation to past, present, and future place identity, and ideally in a variety of place-related contexts and relationship types to improve the explanatory power of the research.

However, two features of Chow and Healey's design were determined as useful for satisfying the aims of the present studies. Firstly, the semi-structured nature of their interview schedule, and secondly their phenomenological, or realist, approach to the interviewees' accounts. Together these features are particularly useful for exploring participants' experiences and emotions associated with places. Indeed, these methods have been commonly employed by authors interested in the emotive dimensions of place identity. Realist interpretations of the data are particularly appropriate for examining perceptions, such as place identity continuity. The authors claim this approach allowed them to probe the 'deeper understanding' of these topics, demonstrating the utility of this type of qualitative methodology for exploring whether place-related continuity results from multiple place

identities, and whether it does so in a future-oriented, as well as past-oriented, manner. More generally, it is ideal for exploring whether people actually think of their relationships with places in temporal terms, because it allows for flexible exploration of place relationships that is responsive to participants' accounts.

Realist interview methods therefore seem most appropriate for identifying the existence of perceptions of place identity continuity. The semi-structured interview has in fact been the most utilised method in the existing place identity literature, although there have been some minor variations in this method. In his explorations of place identity, Korpela (1989, 1992) adapted the interview technique using a free-writing task. He posed open-ended questions to participants and then interpreted themes from their short essay answer responses. These were essentially written interviews with Finnish children aged from mid to late-childhood about their self-selected 'favourite places' used to uncover how places relate to identity functions, primarily that of self-regulation. This methodology allowed Korpela to link favourite places with narrative and self-esteem, as well as revealing how these places are used for fixing memories and providing self-coherence. Again, this work shows that non-directive methods are useful for accessing the varied phenomenology of connections between places and the self in ways that are relevant to issues of continuity. As respondents were allowed to write about any type of place-related experience, this type of open-ended method is ideal for exploratory purposes whilst being approachable enough for children who may feel pressured by responding verbally to an interviewer. This freedom of response was essential but writing tasks were not employed in the present studies due to the adult specific sample, which meant that participants should be more conformable with verbal interactions with the interviewer as long as participating remained strictly voluntary with no monetary incentives.

A phenomenological approach to place identity research has been identified by Lalli (1992) as particularly valuable and successful throughout the history of this research area,

because it does not examine the actual environment, but rather how the individual experiences and relates to the environment, providing cognitive, emotional, and therefore behavioural insights. This is precisely what is needed for the current focus on *perceived* place identity continuity and a conceptualisation of place identity as a part of the subjective identity of the individual (or group), and not the identity of the location itself. This distinction is vital, and contrasts an identification process that develops via the associations between individual and place, in contrast with a place identity that is pre-existent and independent of individual experience (cf. Graumann, 1983).

In contrast, several authors have tackled the issues of place identity continuity with quantitative methods. As discussed in Chapter Two, Feldman (1990) addressed the issue of maintaining ‘continuity of residential experiences’ in a mobile world (increasingly characterised by shifts in residency) by drawing upon the idea that people develop psychological bonds with place-identity *types*, introducing the notion of ‘settlement identity’. This was done using questionnaire studies with employee residents of Colorado, U.S.A. Settlement identity is based on Proshansky’s (1978) place-identity but is defined as a generalised identity relating to all settlements of the same type, this settlement identity is said to “provide dispositions for future engagement with that type of settlement” (p.190). This survey work, based on a series of earlier interview studies, was part of a large study on public housing but included measures of settlement preference type, positive affect, and evaluations of the distinctiveness of the settlement type.

Crucially, in terms of continuity, Feldman (1990, 1996) measured both consistency of residency type and future intentions to stay in this type of place, as the study sought to explore how settlement identity impacted upon explanations of both past and future residential experience. Feldman argues people try to maintain consistency of identity type and that satisfaction with residency will depend upon this congruency (cf. Twigger-Ross and

Uzzell's, 1996, 'congruent continuity'). However, these measures did not actually tap perceptions of continuity, and instead focussed on the evaluation of the actual place, past residential patterns, and predicted behaviour. Therefore, whilst this approach does speak to calls for place identity research to focus on behaviour (e.g., Devine-Wright & Clayton, 2010), it does not focus on the significance of *perceptions* of continuity in place identity.

As well as not directly examining place identity continuity, Feldman's studies do not identify its correlates and consequences, or examine its existential and identity functions. Although, interestingly, the author does find support for consistency between place identity type, past residency type, and intended future associated with that particular type. Moreover, those participants who reported no preference for any settlement identity type (approx. 16% of the 6,120 employee sample) were characterised by more residential moves in the past and more intentions to move in the future, therefore suggesting identity strength and desire to maintain bonds via residency were related for this sample. These findings suggested it was necessary for the present methods to be able to study variation in place identifications and continuity perceptions among participants.

Lalli's (1992) attempt at adding more specification to place identity research involved a quantitative examination of 'urban-related identity' in the German city of Heidelberg. Using survey methods, he attempted to explore the significance of this type of place identity by developing a five component scale of urban place identification; one of these components was labelled 'continuity'. He operationalised continuity as "the significance of the urban environment for the sense of subjective temporal continuity", allowing a, "connection between [one's] own biography and the town" (p.284). His version of continuity again refers specifically to connection with the past. Lalli used these components – each measured using four Likert-style questionnaire items – to predict the significance of different elements of the

city identity and demonstrated the role of the continuity dimension in predicting positive place evaluations by city residents.

In addition, Lalli (1992) showed that both length of residency and past-related continuity were correlated with each other and each of the other urban identity dimensions: attachment, evaluation, and familiarity. A positive correlation was also found between continuity and 'commitment', suggesting both past *and* future-oriented cognitions. Personal commitment to the city was conceptualised as maintenance of self-concept stability, a feeling of being connected with the future of the city (by continued residence), and an interest in the future of the city. Scores on both the continuity and commitment subscales of urban-related identity (as well as the remaining three subscales) positively predicted scores on residents' ratings of the town's importance, and so these subscales were taken as valid measures of urban place identity.

Despite the fact that this represented one of the only empirical attempts in the field to measure place identity continuity whilst acknowledging thoughts about the future, continuity with personal past and commitment in the future are mere components of identity in Lalli's study, and not constructs in their own right. Therefore, when determining the impact of multiple residential moves on identification, past continuity is taken as measure of identification itself. This is a significant limitation of the study because it inhibits any independent study of continuity as predictor, mediator, or criterion variable in relation to place identity. The quantitative studies reported in this thesis included independent measures of place identity continuity to overcome these limitations.

Social Psychological Methods

As noted in Chapter Three, several studies from the social identity tradition have featured reference to the role of places in identity, but for the most part these have involved a treatment of place as representative of social groups and categories. Amongst these can be included the studies by Bonaiuto, Breakwell, and Cano (1996), and Levine and Thompson (2004). Others have been invaluable in demonstrating that places are implicated in specific identity-related behaviours, for example, decisions about residential mobility in relation to national identification and belonging, using both interview (Hopkins, Reicher, & Harrison, 2006), and experimental methods (Reicher, Hopkins, & Harrison, 2006). Others have used a mixture of discourse analytic and interview techniques to demonstrate how places can be used to represent particular versions of national identity and citizenship (Abell, Condor, & Stevenson, 2006), and how they can be used to negotiate the civility, acceptability, and legitimacy of certain local social acts, ranging from public alcohol consumption (Dixon, Levine, & McAuley, 2006), to fox-hunting (Wallwork & Dixon, 2004), through to larger scale issues such as racial segregation (Dixon & Durrheim, 2000, 2004) and the control of 'transient' travelling populations (Barnes, Auburn, & Lea, 1998, 2004).

These studies, whilst indispensable in highlighting the importance of place in a discipline where it has been largely excluded, have not been able to speak to the issue of place identity continuity whilst recognising place as a part of identity in its own right. Several key studies have however spoken to the issues of temporality and history. Both Lewicka's (2008) study and that of Devine-Wright and Lyons (1997) highlighted the inherent value placed on place history for the collective identity of residents using large-scale survey methods. Devine-Wright and Lyons' study even made specific reference to the significance of the national group's sense of continuity with the past. It should also be noted that these

studies have demonstrated that a variety of approaches, from qualitative to quantitative, can be employed to explore issues of place and identity. The experimental manipulation of place-related behavioural intentions (cross-national labour mobility) with social identity primes by Reicher et al. (2006) is particularly note-worthy, and constituted a potentially useful approach for the present research program to explore variability in place-related perceptions.

Within social psychology it is the studies using Breakwell's (1986, 1992) Identity Process Theory (IPT) of identity that have been the most useful in examining continuity resulting from place identity as a distinct component of self. Twigger-Ross and Uzzell's (1996) study with residents of London's Docklands classified as either place-attached or not place-attached, led the way in this research program. In accordance with the identity process model, they studied place identity continuity as an identity process in combination with the other guiding identity principles of self-esteem, self-efficacy, and distinctiveness³. As stated earlier this approach argues for a version of identity that is psychologically constructed through processes of affect, action, and thought; based upon both content and evaluative planes of identity; and governed by certain identity principles that control identity construction and maintenance. Each identity principle directs processes of accommodation/assimilation and evaluation that are dynamic and constant (Breakwell, 1986, 1993, 2000). Twigger-Ross and Uzzell (1996) therefore looked for evidence of desire for each identity principles within residents' accounts of their place identities. To do so, they use thematic analysis of interview data gathered during a time of significant residential change in the area during the 1990s.

³ Note that when this study was conducted only these four main identity principles had been explored in the IPT model and additional principles of meaning and belonging were not added until later.

The results of their thematic analyses, which they state have a ‘broadly inductive’ and ‘empiricist’ approach, allow them to draw two main conclusions: that interviewees’ accounts of their place identification are guided by satisfaction of each identity principle, and that this occurs for those who express strong place attachment but not for those that express no, or negative, place attachment. Importantly though, using this social psychological approach allows the authors to add the necessary process-based account previously lacking in the place identity literature. However, as noted earlier their conceptions of perceived identity continuity are limited. That is, like Lalli (1992) and Chow and Healy (2008), they refer only to continuity in terms of a past connection with the place, termed ‘place referent continuity’. Although they also add ‘place congruent continuity’ to refer to the maintenance of continuity through identification with similar ‘fitting’ place characteristics (cf. Feldman, 1990, on settlement identity). This reflects Breakwell’s initial theorising on the continuity principle, where for example, she has claimed that “continuity can be associated with growth and change which require inconsistencies between *past and present conceptions of the self* just as long as these changes are congruent with the development of the same identity” (Breakwell, 1993b, p.205, emphasis added). However, as discussed in Chapter Three this is problematic in terms of the current interest in a fuller conception of perceived continuity that is in line with social and clinical psychological models describing a connection between past, present, and future.

This particular line of IPT place research has been continued by Gerda Speller and colleagues based on a longitudinal interview study within a traditional English coal mining community undergoing large-scale architectural redevelopment (Speller, 2000; Speller, Lyons, Twigger-Ross, 2002; Speller & Twigger-Ross, 2009). These studies focussed on the experiential understandings of these events. Using thematic analyses these experiences were linked with social variables, like isolation and reduced support, and behavioural outcomes

like competitiveness between residents. More importantly, they have continued to highlight the role of identity processes in place identity and have therefore considered the role of places in providing a sense of identity continuity. However, like Twigger-Ross and Uzzell (1996), they have primarily focussed on a lack of continuity and disconnection with the past, and a sense of incongruency with place. Although they do mention in their discussion that they perceive a distinction between people who think of themselves in a 'static' sense and others who present a more 'developing self', there is no coding of future-oriented continuity.

Indeed, they consider residents' desire not to move from their location in the future as evidence of place referent continuity, because it is justified by past experiences in place. Speller and colleagues' (2002, 2009) idea of a developing self seems to imply a projected self, but because they do not label it as such final coding of continuity in their interviews included only three themes: 'collective continuity', relating to changes in the feeling of community and social interactions post-relocation; 'spatial continuity', relating to changes in the physical layout of the community; and 'continuity through possessions', relating to the use of material objects to maintain continuity post-relocation.

In more recent years, there has been one IPT study including a fuller conceptualisation of place identity continuity. Droseltis and Vignoles (2010) conducted a questionnaire study with members of the general public and used multilevel modelling techniques to build an integrative model of place identity, to identify its predictors and dimensions. However, their treatment of place identity continuity consisted of only one questionnaire item requiring a level of agreement about the perceived connection between past, present, and future continuity of primary place identities. Apart from concern over single-item scales usually being psychometrically inferior to multiple-item scales (Gosling, Rentfrow, & Swann, 2003), this approach also did not allow for any exploration of distinct continuity dimensions (e.g., past and future) unlike the earlier IPT studies (Twigger-Ross &

Uzzell, 1996; Speller et al., 2002). Moreover, because the study did not make continuity its focus, the exact nature of this aspect of place identifications was left to be fully elucidated.

Drawing upon the methodological critique of the above studies, it is clear that studies in this area have commonly used interview methods exploring participants' place-related experiences. They have also convincingly demonstrated the utility of qualitative approaches in exploring temporally-orientated perceptions relating to place identifications. Moreover it seems quantitative approaches have also explored these issues to some degree. Commonly using questionnaire-based designs, they have provided a potential means of measuring perceptions, behaviours, and emotions relating to place identity. However, both qualitative and quantitative studies have been limited in their treatment of place identity continuity and have consequently not provided results relating to any future-oriented perceptions of place identity continuity.

There are several potential reasons for these omissions. Firstly, it might be that analytic interpretations were guided by researcher expectations of how places might provide a sense of continuity of self, mediated by existent literature emphasising the significance of history and memory in determining place identity. On the other hand, it could simply be that people do not have a future-projected sense of place identity, and therefore place identities are not discussed in this manner in interviews. However, it is essential to recall that articulation of relationships with places can be difficult, and uncommon, outside contexts that engender place identity threat. This poses a challenge for the detection of the future-related components of place identity continuity precisely because it becomes hard to determine whether the projection of place identity is psychologically unimportant, and therefore not an intuitive way to perceive these particular dimensions of identity, or whether it is a question of access to these complex, existential, and abstract, identity processes.

The resolution of these issues remains a vital task of this thesis. However, it is encouraging to note that studies of perceived *collective* continuity have explored perceptions of future continuity in relation to social dimensions of identity. These studies have used quantitative questionnaire methods, with both correlational and experimental designs (see Sani et al., 2007, Sani, Herrera & Bowe, 2008), although they too have not measured perceived identity continuity using distinct temporal orientations. In sum, the above critical analysis suggests qualitative methods cognisant of potential future-related identity dimensions could determine the nature of place-related perceptions in interviewees' accounts. Moreover, it suggests that a combination of qualitative and quantitative methods might be the most fruitful approach to satisfy the thesis aims in full.

The Argument for Mixed Methods

As has been shown, there have been several attempts at quantifying specific dimensions of place identity. However, as Dixon and Durrheim (2000) point out, Proshansky (1976) himself was wary of a move towards a social psychological analysis of place identity, because this process of quantification into measureable variables risks neglecting and obscuring the phenomenology of place identity – the essence of what the *experience* of connection with a place is. As this thesis is concerned primarily with exploring perceptions of place identity continuity, that is the sense of identity continuity derived from place identifications, it is essential to capture this experiential dimension of relationships with places, whilst also bearing in mind the limitations inherent in this approach. By doing so, it is hoped that an accurate assessment of the nature and nuances of place identity continuity can be achieved.

The critical review of existing methods above suggests that a qualitative interview-based approach is an appropriate means by which this assessment can initially be made. Also

that the use of thematic analyses, that code, describe, and interpret themes within interview transcripts, has been one of the most common methods employed thus far. Interviewing is well-known as an alternative to close-ended survey approaches as it allows a deeper, more considered set of participant responses representative of interpretations, perceptions, and emotions (Byrne, 2004). Accordingly, it has been suggested as appropriate for investigation of psychological phenomena from a vast number of theoretical domains, and with different epistemological and analytic commitments.

Thematic analyses of interviews have been recommended as a useful analytic approach to tackle both the usual data-driven, inductive coding of data and also more deductive, or theoretically-driven, coding (Boyatzis, 1998; Braun & Clarke, 2006; Fereday, & Muir-Cochrane, 2006). This latter approach is ideally placed to answer questions regarding prevalence and type of continuity perceptions, as it allows active and targeted searching for themes relating to place identity continuity within participants' accounts. Indeed closer examination of the several IPT studies directed towards place identity reveals a similar approach, where evidence of each identity principle is identified in a theoretically-motivated manner, although the approach is not labelled specifically as such (e.g. Twigger-Ross & Uzzell, 1996). Moreover, although thematic analysis has generally been critiqued as being vaguely defined despite its common use, recent publications have provided clear and specific guidelines on the procedures associated with successful interviews and analysis (e.g., Braun & Clarke, 2006).

Being clear about the most appropriate choice of method and approach for each research question is perhaps the most important of the thematic analysis steps in these procedural accounts. Therefore it is necessary to be mindful of the suitability of chosen methods, the nature of the data collected, and the epistemological understandings of what that data represents, that is, the status it is given (Silverman, 2011). This means considering

whether the data is representative of some inner reality, reflecting the mental states of individuals, or if the data are merely the words people actively use within interactions. As this decision determines the suitability of realist or discursive paradigms for the studies conducted within this thesis, it is necessary to discuss this issue in some depth before considering the potential of mixed methods approaches.

The bringing together of social psychological theory with environmental psychology's accounts of place identity has been set out as one of the aims of this thesis. As such it is desirable to draw upon a full range of approaches offered by each discipline to satisfying the thesis aims. Dixon and Durrheim (2000, 2004) have claimed that place identity may be a topic around which the two disciplines can meet. However, they have made a convincing case for doing so by reconceptualising place identity as a collective construction that "helps participants makes sense of their locatedness" (Dixon & Durrheim, 2000, p.40). Specifically, they suggest a relocating of the focus from the internal to the rhetorical, by moving away from an examination of interview accounts as representative of inner states to one that is representative of strategic and ideologically-influenced dialogue and behaviour. By using this discursive approach they facilitate explorations that reveal the social and political dimensions of place relationships and processes of legitimization and belonging, as discussed earlier in this chapter.

This discursive approach has also been successfully employed by Stephanie Taylor in her thematic analysis of semi-structured interviews exploring how women construct their identities in narrative terms using place identifications (Taylor, 2003, 2005, 2010). Taylor's research program has perhaps contributed most to current literature on place identity in relation to continuity, as she specifically explores the role of places in women's past *and* future identity. However, what she is interested in is how women use places to construct versions of self. For example, she describes how they draw upon notions of continuity to

validate their claims about belonging using cultural repertoires such as the ‘born and bred’ narrative.

Whilst the chosen methods in this thesis most certainly do not refute the importance of these constructive, sense-making processes, examinations of that sort do not accord with the primary task of developing a perceptual account of place identity continuity. However, the research proceeded with acknowledgment and mindfulness of discourse analysts’ concerns over whether there can ever be genuine access to these internal representations (Potter & Wetherell, 1987). That said, this work was not aimed at developing a purely individualistic, deterministic, or ‘acontextual’ account, and therefore sought to employ multiple research methods and designs to avoid this (see Speller & Twigger-Ross, 2009).

In their move towards a discursive approach, Dixon and Durrheim (2000) not only sought to expose the political dimensions of place relations, and the dialogues surrounding them, they also tackled the over-individualisation of place identity theorising. These critiques (see Chapter Three), have been echoed by many researchers arguing that individualised approaches neglect the inherently social elements of place relationships. This individualistic critique was to be tackled in this thesis by exploring the social predictors of place identity, specifically the impact of context on place identity perceptions, and by exploring a collective version of place identity continuity. Whilst this approach does not speak directly to the politicisation of place identity and its strategic use in the way that a discourse analysis would, it addressed the need for a context-sensitive account in place identity research, whilst also providing a means by which the similarity of processes between social identity and place identity can be examined. Moreover, it sought to challenge dominant, normative definitions of place identity that approach the phenomena from a deterministic perspective where place identity – specifically one characterised by a sense of continuity – is a fixed, static, and desirable dimension of self.

In light of this aim, the research included in this thesis not only included a phenomenological examination of place identity perceptions using qualitative methods, but also sought to quantify perceptions of place identity continuity. This was done to compliment – rather than supersede – qualitative conclusions and support reliability. However, it was also aimed at providing further opportunities for exploring the significance and variation of place identity continuity in all its dimensions. In addition, it sought to provide measures that could be used in an experimental examination of the context-specificity of place identification and place identity continuity. In adopting such a mixed methodology, certain considerations must be kept in mind, particularly the tensions between these two types of methodological approach within psychology.

The debate between qualitative and quantitative methods has been a central feature of psychology, with many perceiving a general dominance of quantitative psychology resting upon commonplace claims over its ‘superior scientific rigour’ (Danziger, 1985; Kidder & Fine, 1997; Todd, Nerlich, & McKeown, 2004). However, within social psychology concerns over reductionism and the limits of positivism have meant that qualitative methods have enjoyed a revival (Hogg & Vaughan, 2010; Pancer, 1997). Some authors have argued that the divide between the two is essentially artifactual, partly due to the subjectivity inherent in all empirical approaches, but also because both encompass multiple methodologies with quite distinct epistemological assumptions (Hammersley, 1996), as evidenced in the above discussion regarding interview analysis strategies.

Realisations such as this have led some researchers to extol the merits of a research program that draws upon both paradigms. This does not mean to say that 'methodological eclecticism' should be employed without the reflexivity so valued by qualitative researchers; instead this should be a considered methodological approach adopted because it satisfies

specific, relevant aims. In doing so the researcher must also be cognisant of the distinctions between qualitative approaches, which draw on the individual's own subjectivity to form conclusions, and quantitative approaches that seek to form conclusions from a population of individuals based on statistical estimations (Todd et al., 2004).

To date, multiple research programs have benefitted from this methodological plurality in various areas of psychological research, see for example Nicholson's (2004) work combining findings from interviews with new mothers and quantitative clinical data on post-natal depression. Within social psychology, Haslam and McGarty (2010) also suggest that it is not necessary to be rigid in allegiance to either qualitative or quantitative research methods. They argue that the division between them is not as clear as it first appears, and that it is useful to employ a variety of approaches that are relevant and appropriate for addressing specific aspects of an overall research program. They suggest that, "the benefits of a multi-faceted approach to psychological enquiry are well illustrated" (p.392), and cite Steve Reicher's work on the psychology of crowd behaviour as an example of this sort of research program. They argue that the achievement of such a 'rounded theoretical analysis' stemmed from the use of interviews with content analytic (Stott, Hutchison, & Drury, 2001) and discourse analytic methods (Potter & Reicher, 1987), observational studies (Reicher, 1984b), and experimental paradigms (Reicher, 1984a); each of which furthered understanding of this complex topic.

Likewise, researchers contributing to the social psychological literature on place have also adopted this multi-method strategy. For example, as discussed earlier in this chapter, Hopkins, Reicher and Harrison (2006) described participants' use of place as a feature of national identity to justify their feelings about occupational mobility. The authors then supported and supplemented these findings with an experimental study that manipulated

national identity salience. By examining how this affected responses to hypothetical job offers both within and across national boundaries, they were able to determine that Scottish participants were less likely to endorse cross-border relocation when their Scottish identity was salient. This kind of triangulation has been put forth as a means of achieving increased validity in research programs, as long as the methods used are complimentary (Brewer & Hunter, 1989; Denzin, 1989).

Along with triangulation, the other benefits of mixed methods approaches include: comprehensive and complete exploration of a research topic; greater access to the nuances of complex topics; an offsetting of specific methodological limitations with the strengths of others; help in explaining the results of each study using the findings of others; the refinement of research questions; and finally instrument development – particularly by using qualitative methods in advance of creating quantitative measures (Robson, 2011). The studies reported in this thesis seek to achieve these benefits by employing a ‘concurrent triangulation design’ (Creswell, 2003), which uses various methods whilst focussing on one topic: perceptions of place identity continuity.

The Proposed Studies

At the end of Chapter One, a set of specific aims of the thesis were laid out. These were as follows:

- 1) to establish whether the link between place and identity can be accounted for with reference to perceived identity continuity;
- 2) to explore the significance of the future dimension of place identity continuity;

- 3) to bring together identity process theory accounts of place and identity, with those of self-categorisation theory and place-identity theory using a social psychological approach.

With these specific aims in mind, and in the context of the above critical analysis of existing methodologies, the following studies were conducted as part of the research program described in this thesis.

Study 1 reports the results of initial explorations of place identity continuity in the form of twenty semi-structured interviews with participants of varying ages, backgrounds, and residential histories. The resultant interview data were analysed using a hybrid model that incorporated both deductive, theoretical thematic analysis and inductive, exploratory thematic analysis, following the guidelines laid out by Boyatzis (1998) and later elaborated on by Braun and Clarke (2006). This methodology was chosen in order to provide an understanding of place identity continuity grounded in people's own accounts of their experiences and identification with places. The deductive nature of the thematic analysis facilitated a search for evidence of whether participants' relationships with places – their place identities – provide them with a sense of identity continuity. A particular aim of the study was also to expand the existing literature on place and continuity by looking for the existence of future oriented place identity continuity. In doing so, it was hoped two specific objectives would be achieved. Firstly, evidence of a fuller temporal conception of place identity continuity would be described to bring place identity theorising into line with psychological understandings of personal and social identity. That is, to provide evidence that perceived continuity derived from place identity is akin to personal and social identity and goes beyond the past and present focussed versions currently found in environmental psychology. Secondly, the results would provide a background for the remaining studies

grounded in the nuances of participants' own experiences and perceptions, in order to lay the ground for the creation of quantitative measures of place identity continuity.

The studies that follow Study 1 mark a move towards a quantitative analysis of a newly developed construct 'Place Identity Continuity' (PIC). In Chapter Six, there is a description of Study 2, a large cross-sectional survey study conducted with Scottish students, which develops a scale to measure the construct. This scale was developed drawing upon a combination of the results from Study 1 interview accounts of place identity continuity, existing studies of perceived *collective* continuity (Sani et al., 2007), and the findings of Twigger-Ross and Uzzell's (1996) seminal study on place identity processes. The scale was therefore designed to tap on distinct dimensions of PIC, these being place referent continuity and place congruent continuity, both drawn from Twigger-Ross and Uzzell's findings, and the proposed place future continuity dimension. The scale structure was confirmed using exploratory and confirmatory factor analysis to develop a robust, reliable, and valid measure. The relationship of each dimension of PIC was then examined in conjunction with other key place-related measures, such as place identification and place attachment, to explore the initial correlates of past, present, and future place identity continuity. This was done to promote understanding of the construct and establish the validity of the scale. This set of analyses also allowed for questions regarding the relationship between perceptions of place identity continuity and the strength of place attachment and identification to be answered.

Study 3 was a second large scale survey study, this time conducted with a general public population to confirm the validity of the measure beyond a student sample. The scale structure was confirmed using factor analysis to avoid confirmation bias and provide further support for the reliability of the PIC measure. This study sought to extend the exploration of PIC by identifying the links between these perceptions and key variables such as residential history, age, and mobility beliefs. In addition, this study sought to speak to issues of

variability in place identity perceptions by exploring the impact of identity continuity strategy on PIC (Chandler et al., 2003). Finally this study further explored the significance of PIC by extending existing empirical and theoretical literatures that describe the potential links between place relationships and mental health. This was done using mediation analysis to explore the impact of PIC dimensions on psychological well-being.

Study 4 involved an experimental paradigm added to test the contextual dimensions of PIC, as well as general place identity and attachment. This study therefore sought to examine whether place identity continuity is in fact flexibly perceived dependent on the situational context and the particular aspects of participants' identities that these make salient. The design of the study drew equally on the results of Study 1 and existing literature from social identity research showing subjective ratings of 'stable' personality characteristics can be experimentally manipulated (e.g., Reynolds, Turner, Branscombe, Mavor, Bizumic & Subašić, 2010). This led to the design of a study that involved manipulating the salience of two specific social identities, each expected to be differentially related to the hometown place identity. In correspondence to the observations in the interview data, the two social identities selected were 'student' and 'family member'. Each identity was primed experimentally across two conditions to increase its salience before participants rated their own hometown place identity on the PIC measures.

These rating scales were administered to explore whether contrasting endorsements of place identity, and perceptions of the continuity of that relationship, occurred between conditions. It was hypothesized that perceptions of place identity continuity should be higher in the family identity condition as interview data suggested this collective was commonly associated with the hometown, whereas the student identity commonly represented a breakaway from the hometown and the life-stage it represented. Measures of age and social identification were included as control measures, as well as a number of additional measures

relating to the strength and significance of the place-person relationship. These latter measures were included to explore any potential moderating influences they may have on the relationship between social identity and place-identity continuity. Moderated regression techniques were used to achieve these ends.

The addition of this final study was motivated by concerns over static and deterministic conceptualisations of both place identity in general (Easthope, 2009; Speller & Twigger-Ross, 2009), and place identity continuity specifically, and sought to add a contextualist element to the study of place identity continuity. It was hoped that in doing so it could be shown that whilst place identity continuity is valuable in some contexts, it might be less relevant in others, thus demonstrating the inherently complex but flexible nature of relationships with places in modern western society, at least for those who are afforded choices over place relationships and residency. These studies will be presented in the remaining chapters of this thesis.

PART II: EMPIRICAL STUDIES

CHAPTER FIVE

Study 1: A Qualitative Exploration of Place Identity Continuity

Introduction

The preceding chapters of this thesis have described and evaluated the extant literature concerning identity continuity derived from place relationships. It has been claimed that research influenced by Breakwell's (1986, 1992, 1994) Identity Process Theory has been most productive at providing direct accounts of the construct. As has been stated, the identity process model includes a specific 'continuity principle' which describes the impact of on identity of motives to preserve continuity of self over time. This continuity principle has been detailed by those who have used identity process principles to study the psychological consequences of place change. Speller (2000), for example, suggests this relates to, "a person's sense [of] persistence over time, linking past, present and future self-concepts and includes any references to any break in continuity in terms of temporal, social, spatial or cultural aspects of the person's self or life." (p. 156). However, as she observes, only evidence of 'place referent continuity' - place as a reference point for past selves and actions - and 'place congruent continuity' - where place features are transferable and aligned with current conceptions of self - are evident in the interviews conducted by Twigger-Ross and Uzzell (1996). These findings persist over the course of the subsequent studies based upon this paradigm, meaning that reference to future place identity is not represented in the research evidence and is therefore largely absent from the discipline.

It is very possible that this is due to the reasons discussed during Chapter Four, specifically that previous theory may have influenced analytic procedures or that place may not be conceived of as readily in terms of future selves as they are in terms of past experience

and present needs. However, a third possibility exists: the particular research contexts involved might have influenced participants' discussions of the specific places relationships studied. This is because in each case the interviews are focused on reactions to place change and therefore potential place loss. In this case it might be harder for, and less likely that, participants would think about these places as parts of their future identity and the loss of places relating to their past might be far more salient.

This study seeks to address these issues by exploring whether places are in any way related to future identity as well as past and present identity, be that in an individual or collective sense. To provide an opportunity for these types of perceptions to be exposed, it is necessary to conduct a study with people of various backgrounds, age groups and residential histories who are not specifically defined by forced dislocation from particular place identifications. Whilst it is not always possible to provide a truly diverse group of participants when the research is conducted in one location and an infinite amount of interviews cannot take place, sampling techniques were focused on recruiting as broad a sample as possible.

This sort of broad sampling strategy was employed in the discourse analytic studies conducted by Stephanie Taylor (2010). Taylor's studies were motivated by sociological accounts of a modern day society as increasingly characterised by mobility and rootlessness, and an interest in how women negotiate their identity in relation to place within this context. This meant her sample consisted solely of women, but she did interview a relatively large sample (twenty participants) with varying residential histories. Crucially this sampling technique, and its narrative-based procedure, uncovered references to women's future conceptions of self in terms of their place identities, and revealed how place relationships appear in projected narratives (Taylor, 2003, 2010). Although Taylor's studies concern the construction of identities and place relationships using discursive narrative resources (e.g.,

the born and bred narrative), these findings nevertheless suggest that the future is a relevant dimension upon which to consider relationships with significant places.

As the study is concerned with identifying evidence of place referent continuity and place congruent continuity, a fuller description of how these constructs are conceptualised in the existing literature will now follow. The labels used for each will be retained within this research program for the sake of consistency and transferability of findings. The next section will also provide an account of what will be termed 'place future continuity', which draws upon the existent theoretical literature discussed in Chapters Two and Three.

Place Referent Continuity (PRC)

Place referent continuity is the first type of continuity that places are said to facilitate by providing a trigger for memory and connecting the individual or collective to their past identity. This is a process that is challenged following relocation or substantial place change (Speller, 2000). Milligan (1998) suggests that places can act as 'mnemonic devices' that endorse the veracity of memories, highlighting the important role of nostalgia for reconnecting to one's past in place. Korpela (1989) similarly refers to places as 'fixing aids' for memory in environmental settings that create continuity of self-conceptions. Several studies have also explored the desire for continued residency and conservation of places as a means of harnessing memories and connections with past versions of self and group (e.g., Devine-Wright & Lyons, 1997; Rowles, 1993). Twigger-Ross and Uzzell (1996) suggest that it is through these functions that places help support identity. In their interviews they considered evidence of place referent continuity to be shown if interviewees used self-relevant places to relate past activities and aspects of self to their present selves, for example, through explaining how a place used to be at a certain point in their lives.

Place Congruent Continuity (PCC)

Place congruent continuity is distinct from place referent continuity in terms of place specificity because it is not necessarily linked with only one place, but is rather linked to specific place *features* that are felt to be consonant with the individual's values, and hence sense of self (Twigger-Ross & Uzzell, 1996). Feldman's (1990) settlement identities provide evidence of the ways that people can maintain a sense of continuity of self via identification with multiple *suitable* places, for example, as a 'city person'. Individuals will therefore continually seek out places that match their values and are congruent with their self, and will be dissatisfied with places that have become perceptually incongruent. In Twigger-Ross & Uzzell's coding scheme evidence of place congruent continuity was judged to be present if the interviewee discussed their relationships with places as based upon a sense of fit between the place and themselves, in terms of needs, values, and place features. For some of their interviewees this was done by comparisons between incongruent current residences and more congruent past places. Substantial evidence of this type of place identity continuity and perceived referent continuity was found in both their interviews and those that followed (e.g., Speller et al., 2002).

Place Future Continuity (PFC)

According to Twigger-Ross and Uzzell's coding scheme, evidence of continuity was centred on accounts of the interviewees' residential *history* in accordance with the principle of continuity relating to "past and present self-concepts" (p.207). Accordingly, although the work by Speller and colleagues has alluded to a future perspective they have not interpreted it as such. Specific literature discussed in Chapter Two also includes a future perspective, suggesting that future continuity might be expressed through support for heritage preservation for both future self and future generations (e.g., Milligan, 2007). The place

attachment literature discussed in Chapter Three also suggests that places can provide a secure base (e.g., Chawla, 1992) suggesting that people have some representation of places as available in the future; this is echoed to some degree in the interview accounts described by Speller and colleagues (2002, 2009).

Taylor's (2010) interviews provide a direct examination of places in relation to a constructed future, although in accordance with available societal narratives and interactional agendas. Some of her interviewees construct a continuing future in place by drawing upon family connections and rootedness that allow them to either remain in, or later return to, the place they 'belong', whilst others draw upon suitable place features as guiding future identity constructions (cf. place congruent continuity). Others are found in situations of broken future continuity and therefore employ alternative strategies of identity construction. In sum, although it has not been coded for before, existing literature suggests that perceptions of future continuity might be evidenced in reference to various topics: projected selves, future self-development, a secure base, heritage and preservation, continuing belonging, and anticipated seeking of specific place types.

Further Considerations

As well as seeking to ascertain the existence and nature of place identity continuity, the study also sought to explore the processes underlying place identity continuity. It was therefore essential to address the circumstances in which place might not lead to a sense of continuity, and perhaps not be at all connected to identity or temporality. A full understanding of the relationship between identity and places cannot be gained without an unbiased exploration of this sort, and true insight into perceptions of place identity continuity cannot be gained without considering situations when they may not actually be desirable or positive, despite the psychological evidence that suggests otherwise. One need only consider

circumstances in which individuals seek to distance themselves from past versions of self, such as group experiences of collective guilt and shame over past group actions (Branscombe, Doosje, & McGarty, 2002), to appreciate that the typical 'continuity as desirable' conceptions might not always be useful in explanatory terms. Speller and Twigger-Ross (2009) have already suggested that place-related continuity should not be conceived of in these essentialist terms. For these reasons, and because the corroboration of these claims was laid out in Chapter One as an additional aim of this thesis, the study will also seek to explore the potentially nuanced nature of place relationships and place identity continuity as it is experienced by participants. The precise aims of the study are detailed below by way of summary of these points.

Aims of the Study

This study aimed to identify evidence of continuity-related themes in interviewees' accounts. This proposed 'top-down' approach has been used by various authors seeking theory-confirmation (Akintola, 2011; Hayes, 1997, for example) and differs from typical data-led inductive thematic analysis because interview transcripts are examined specifically for evidence relating to a theoretically specific issue. One potential limitation of a deductive approach of this sort is that it means that instead of examining patterns across the whole dataset, the dataset is instead carefully examined for only relevant themes. This means that interesting information contained within the dataset can be left unanalysed; however a more in depth, fine-grained analysis of the themes pertaining to the particular research question is gained in exchange for forgoing a holistic approach (Braun & Clarke, 2006).

However, although it is necessary to identify these specific features of the data, it has been frequently stated that to be a skilled qualitative researcher it is essential to adopt a conceptually flexible interpretative style (e.g., Boyatzis, 1998). This means that whilst a

focused deductive approach was necessary when identifying references to future-oriented place continuity, it was important not to preclude the possibility that additional themes relevant to the core topic of the thesis would be found in the contents of the interviews. This meant that a hybrid model of the type employed by authors such as Fereday and Muir-Cochrane (2006) was needed. By including both deductive and inductive coding, the study aimed to achieve the following two outcomes:

- 1) A theory-driven deductive analysis of each interview to identify the existence of themes relating to place referent continuity, place congruent continuity, and place future continuity.
- 2) An inductive exploratory thematic analysis of the interview corpus for themes relating to place identity continuity.

An approach of this sort is ideal because it allows fulfilment of the theoretically-driven main aims of the study whilst allowing for an exploration of accounts given by a group of people not bound by a context of place change (as in the studies by Twigger-Ross and Uzzell, 1996, and Speller and Twigger-Ross, 2009). As this approach involves a range of place identifications and residential contexts, exploration can be flexible, contextually-aware and open to the nuances of participants' relationships with place, and therefore well-placed to interpret the circumstances under which place identity continuity is appropriate and useful, and when this might not be the case.

Interview Methods and Design

Concerning the nature of the data, a realist approach was adopted to allow for exploration of the phenomena in question and to give voice to participants' experience. Although, in using this approach it is impossible to make any claims regarding objectivity

and generalisation, the potential depth of exploration and insight gained via participants' verbal accounts of a phenomenon are considerable. It is crucial however that the researcher critically evaluates their interpretations and is cognisant that the nature of participants' perceptions is available only through the window of that subjective interpretative process (Hepburn, 2003; Kidder & Fine, 1997; Prilleltensky & Fox, 1997).

The research was advertised as a study on 'Place and Life Experience'. Place was left undefined so that people would feel free to draw upon a broad range of potential places of varying scales and significance without imposing the researcher's ideas about the primacy of particular place types, albeit with the realisation that the study title may have already primed some swaying of talk in particular directions. A semi-structured interview schedule was used so that themes relevant to place identity could be covered in a way that allowed comparison across interviews in terms of the key issues of place and identity. The schedule included a series of initial opening questions inviting participants to describe themselves and their lives, with the expectation that talk of places would naturally occur during the interviews. The open-ended format of the initial statement allowed the participants to develop a rapport with the interviewer promoting willing disclosure and the structuring of experiences in a narrative form (see Willig, 2001). This approach was thought to lend itself well to discussion of places and identity in terms of temporality, and to allow the participant to exert more control over the direction of conversation and topics discussed (Babbie, Mouton, Vorster & Prozesky, 1998). The schedule outlined the key place topics arising from the literature review, and those that permitted issues of place-related continuity to unfold, should these issues be relevant to the participants. These topics included: i) residency and attachment; ii) place experience; iii) identity; iv) social groups; and v) place loss/change.

Participants

Participants were recruited using the weekly university e-mail newsletter. Posters advertising the study were also displayed in and around the university campus to recruit students and staff of the university, as well as members of the general public to gain a diverse sample⁴. However, it should be noted that sampling was undoubtedly influenced by the location and nature of the university area and the specific populations that frequent this more affluent area of the city. This sampling technique resulted in the recruitment of twenty participants. Participants were of mixed sex (12 females and 8 males) and ranged in age between 19 and 77 years. Several participants were students, five were in full-time employment, one was completely retired, and two were retired but studying part-time. Many participants were parents but a roughly equal number were not (11 and 9 participants, respectively). Participants varied according to nationality, with one Polish participant, one Greek, and one Canadian, all of whom were also students studying at the university. The remainder either identified themselves as Scottish (5 participants) or British (12 participants), although several of the British participants had moved between Scotland and England and found it difficult to classify themselves in accordance with either of these nationalities, therefore adopting the British label. Others dealt with difficulty in identifying a primary nationality due to considerable residential mobility, by categorised themselves with references to their country of origin.

All participants shared the common feature of current residency in or around the Tayside area of Scotland, affording them access to campus. In all other respects their residential histories varied, with some participants living at home in the town or village of

⁴ Each participant is referred to only by participant number in order to avoid promoting any perceptions of their personality or background (for example, P1).

their birth, others having moved from one area of Scotland to another for the purposes of University study or employment. Others had travelled and resided in several countries, usually involving moves between British nations or European transitions, but one had relocated trans-continently. They also varied in terms of the people they resided with, be it partners, friends, or peers, and they often varied in terms of how close they were to their families; this was a prominent feature in several interviews and often defined how people related to places.

Finally, it is pertinent to note that because the title of this study involved the word ‘place’ people especially interested in this topic may have been more likely to volunteer themselves. Whilst a qualitative study of this sort does not seek to ignore, or statistically iron out, individual preferences and interests, it is however important to note at the outset that certain beliefs and values may be expressed in relation to place identities because of these vested interests. Finally, it is useful to provide some further individual information on the circumstances of each participant for two reasons: i) previous literature has suggested the residential histories, present circumstances and life-stage of individuals are potentially impactful on relationships with places, and ii) because the study involved individuals with varying backgrounds, awareness of the circumstances each participant brings to the study can help the reader judge the validity of interpretations. A short summary of the history and circumstances of each individual is therefore provided in Appendix Two⁵. These accounts do not seek to be exhaustive or claim to be the exact or only accounts of the participants’ lives. Rather, they summarise the accounts provided during each interview. Moreover, they do not claim to be diagnostic in any manner, as this thesis is not concerned with providing

⁵ Any detailed identifying information has been removed, including names and specific dates. Larger locations like cities have been retained in order to provide an accurate context, but more detailed smaller-scale locations (e.g., particular suburbs) have been omitted for confidentiality reasons.

any kind of psychoanalytic or developmental account of place relationships. A summary of key participant characteristics can be found below in Table 5.1 in order to provide a simplified overview.

Procedure

The interviews took place during spring and summer of 2008 in the social psychology lab of the Department of Psychology at the University of Dundee. This location is not irrelevant as it necessarily brings with it a set of assumptions about the 'scientific' nature of the study, which can impact upon participants' expectations and dialogue, as well as potentially influencing the dynamics between researcher and participant. Interviews were tape-recorded, which began following satisfaction of ethical procedures. The interviews varied as expected between participants, with some giving a detailed description of themselves in a narrative sense throughout the interview and others providing only a brief response to the initial questioning, then describing in more depth specific places of significance for them. During each interview, the researcher used the prompt questions outlined in the interview schedule to probe areas of interest. When the talk drew to a natural conclusion, the researcher ended the interview, thanked and debriefed the participants and provided contact details for withdrawal from the study and any further information. In some cases the interviews had to be brought to a close for the purposes of transcription as they had exceeded one hour, but the majority lasted around 45 minutes.

Table 5.1 Key characteristics and residential history of Study 1 participants.

Ppt. No.	Age Bracket	Marital Status	Sex	Children	Occupational Status	Residential Mobility	Nationality
<i>P1</i>	20s	Single	Female	No	Student	Moderate	Greek
<i>P2</i>	30s	Single	Male	No	Student	Low	Scottish
<i>P3</i>	Teens	Single	Female	No	Student	Low	Scottish
<i>P4</i>	40s	Married	Male	Yes	Student	High	British
<i>P5</i>	40s	Married	Female	Yes	Employed	High	British
<i>P6</i>	50s	Divorced	Female	Yes	Student	High	British
<i>P7</i>	50s	Divorced	Female	Yes	Employed	Moderate	Scottish
<i>P8</i>	20s	Single	Male	No	Student	Moderate	Canadian
<i>P9</i>	30s	Married	Male	Yes	Student	Moderate	British
<i>P10</i>	70s	Widowed	Female	Yes	Retired	Moderate	Scottish
<i>P11</i>	20s	Single	Female	No	Student	High	Polish
<i>P12</i>	20s	Single	Male	No	Student	Moderate	Scottish
<i>P13</i>	40s	Married	Male	Yes	Employed	Moderate	Student
<i>P14</i>	20s	Single	Female	No	Student	Low	Scottish
<i>P15</i>	60s	Married	Female	Yes	Student	High	British
<i>P16</i>	30s	Single	Male	No	Student	Low	Scottish
<i>P17</i>	20s	Single	Female	No	Employed	High	British
<i>P18</i>	60s	Married	Female	Yes	Student	Low	Scottish
<i>P19</i>	20s	Single	Male	No	Student	High	British
<i>P20</i>	50s	Married	Female	Yes	Employed	High	British

Note: Although many participants are listed as ‘student’, many were mature students over 25 years old, three were ex-army personnel now studying for a second career, one was a student nurse doing vocational training, and two were retired but studying part-time. Low mobility was characterised by few moves, usually within a relatively small area of one county, moderate mobility was characterised more than three moves, usually within the UK, and high mobility was characterised by frequent moves, often between several countries.

Analytic Procedure

Analysis of the data began with transcription of each interview and repeated listening by the researcher. Transcription was done verbatim from recordings of each interview using

a simplified version of the notation described by Antaki, Billig, Edwards, and Potter (2003) to describe patterns of speech (see Appendix Three for details). During this period, initial notes were taken on each interview including information on both the history of the participant, their expressed relationships with each place and the places they discussed; this provided the basis for the summaries of each participant provided in Appendix Two.

This also acted as stage one in the stages of thematic analysis laid out by Braun and Clarke (2006) according to their general guidelines for thematic analysis⁶. The analysis then took two specific forms according to each aim of the study. To examine the data for evidence of themes relating to continuity and temporality of place identity, a form of template analysis was used (Crabtree & Miller, 1998). This approach involves creating template codes based on pre-existing research that can be applied to interview data to confirm the existence of particular themes. Themes that are not confirmed are deleted and themes that are found can be developed into secondary level sub-themes, where necessary. To proceed with this technique, a priori codes relating to each dimension of place identity continuity were developed and sought out within the text. Sections of text where each dimension was evident were recorded using colour coding, and then collected together in a separate file.

Following this step, and sometimes simultaneously, each interview was explored for additional relevant themes relating to the main topic. Crabtree and Miller (1998) have suggested that one limit of template analytic approaches can be the removal of the context of the interview from the results. In recognition of this, and because it coincides with one of the aims of the thesis, this second part of the thematic analysis was contextually-oriented in

⁶ Some of the transcriptions were completed by a voluntary team of undergraduate students. In these cases the tapes were listened to by the researcher and the transcriptions checked and amended where necessary. This was done to ensure the accuracy of the transcripts but also to facilitate stage one of analysis.

recognition of identities and place relationships being bound and constrained by the contexts within which they occur.

Following these initial stages, successive re-readings and listening to interviews were again completed to allow the researcher to be fully immersed in the accounts of each participant before second-stage coding. For the deductive analysis this involved the a priori codes being developed into further sub-category codes to capture the complexity of each dimension type. For the inductive analysis, initial themes were developed from the earlier notes and then interpreted into codes that captured the relevant information provided in the interviews.

Analysis and Discussion

Part 1: Deductive Coding for Place Identity Continuity Dimensions

The following sections present the results from the theoretical thematic analysis of the twenty interviews using selected excerpts. Results are organised according to the three main over-arching dimensions of place identity continuity and each of their associated secondary level categories. All twenty interviews were analysed but some interviews will only be referred to briefly, for reasons of space and because their accounts reflected those of others. Each extract contains the original utterances of the participant, however, an approximation of what is said is included in square brackets where speech is unclear, the information has been anonymised, or where the participant is paraphrased due to the lengthiness of their response. Questions and responses are reported where possible, due to a desire to represent the structure of conversation, rather than just chunks of disconnected text.

The initial set of a priori codes used in Part I of the analysis is provided below in Table 5.2, which describes the nature of each code as it should appear in the data. This is

included to promote conceptual clarity of each code and to address the need to provide an explicit codebook at the start of theoretical thematic analyses (Fereday & Muir-Cochrane, 2006). In this instance the codebook consists of three of Boyatzis' (1998) stages of code identification following the approach recently used by DeCuir-Gunby, Marshall, and McCulloch (2011): i) labelling of the code; ii) definitions of what the code means; and iii) an account of how to recognise when evidence of the code can be found.

Table 5.2 A Priori Code Labels and Operational Definitions

	Code Label	Definition of code	Evidence of when code occurs
1.	Place Referent Continuity	Place as reference point to the past	<ul style="list-style-type: none"> - Use of place for connecting past with present self - Accounts of memories represented by place - Accounts of places triggering memory
2.	Place Congruent Continuity	Place as congruent with current identity	<ul style="list-style-type: none"> - Accounts of self as having a place identity type - Identification of place features as incongruent or congruent with self - Accounts of residential history as driven by place fit
3.	Place Future Continuity	Place as connected to future of self.	<ul style="list-style-type: none"> - Accounts of future self in specific places or congruent place types - Expressions of desire to preserve place for future - Accounts of belief in need to return to past places in future

Initial examinations of the transcripts allowed the broad meaning of each section of text to be decided upon (where a section referred to the smallest meaningful segment of interview data). The nature of these sections of text were then compared with each of the

dimensions, and a decision was made regarding whether the data could be interpreted as relating to any of the three pre-existing codes. Once these segments were categorised it became possible to further analyse each to generate the most useful and appropriate secondary interpretations. Borrowing Saldana's (2012) terms, this involved initial decoding of information to aid interpretations that then allowed for final encoding.

During this stage, several initial themes were collapsed in to superordinate categories. For example, within PRC, an initial theme labelled 'familiarity and predictability', associated with the build-up of place-related memories, was combined with a theme relating to places as the 'receptacles of memory'. These became the 'Storehouses of Memory' theme described below. At conclusion, six initial subthemes became five within the PRC main category, and within the PFC main category, seven initial themes became four. Summaries, elaboration, and interpretations of sub-category themes are provided below using examples from transcript excerpts to satisfy the final stages of analysis recommended by Boyatzis (1998), and Braun and Clarke (2006).

Place Referent Continuity

Theme 1: Origin of Me

One of the most prominent ways people relate to places in accordance with their past is with reference to a sense of origins; this being a characteristic that can lead to a deep sense of belonging and identification. For some participants, like P16, just being born in a place underwrites a strong sense of attachment:

P16: Yeah, born in St. Andrews and I really feel like I'm *from* St. Andrews (.) that's like where my spiritual home is I would say (.) so (.) I feel like a big attachment to St. Andrews.

Participant P1 sums this emotion up when explaining why connections to physical places, like her attachment to her home in Crete, occur.

P1: A part of us is the place where we have grown (.) I mean, ourselves is this place (.) and that's why we always, even if we move from this place, we always, go back and it is this place (.) and we always feel better when we are there.

This notion of 'origin' is tied up with a sense of home and, as the following excerpt shows, can also be bound up with the idea of family history, genealogy, and residency. Here P15 describes her childhood home of Bournemouth, a place she still considers home although she has raised a family in the Dundee area.

P15: I was born in Bournemouth and (...) my family, generations, have been in Bournemouth. I suppose thinking about family, my grandparents, and mother, we are quite a close family [*describes them*] I think that's come through the generations.

This importance of Bournemouth as a place of origin persists for her even though her family is not there anymore, but she goes on to describe how nowadays the pull to her place of origin is mediated not so much by her living family but by her parents being buried there.

I: So you probably do have a lot of family in Bournemouth that you...

P15: They are now like second cousins because my great-uncles and great-aunts are now deceased (.) and it's now their grandchildren that are still there, which I wouldn't know. I just sort of vaguely knew them as children.

I: So nobody to go back to visit then?

P15: Not really, but I still go.

I: Oh, do you?

P15: Yeah, every few years I go down. I go to the cemetery.

She goes on to describe still visiting "family places" like the church and the house where her grandmother lived, despite now being in her sixties herself. She closes by describing how the

place always remains a home for both her and her brother, and again reiterates how this is mediated by the fact that her family are temporally ingrained in the place.

I: Is there any (.) do you feel an emotional bond with Bournemouth then?

P15: I suppose so because I still speak about it as home. Ehm, especially with my brother, he was on the phone this morning, and both of us, we actually use that term 'down home'. [I: Mhmm] Now both of us have lived in Scotland for years and years and years but I suppose that's what we mean.

I: And what is it that makes it home do you think, for you, because it's not somewhere that you live?

P15: No, no, no, and I've not lived there since I went to train, when I was eighteen. No, I suppose it's just the association of all the family. Numerous generations were there [...] I can remember my great-grandfather knew Bournemouth City, the square which is the main thing, when it was a field with a river. And my grandfather built the groin that goes out from the beach along so there's part, quite a lot of family still there in one way or another. Not in people or person, but in part of the time there.

This interview closes with another interesting observation that reasserts the importance of a sense of origin in place relationships. In her account P15 talks only of Bournemouth as her home, despite having many residential changes through her lifetime. Near the end of the interview, she describes one other place that has this significance for her: a town in Belgium where her maternal grandmother and the rest of her relations come from.

I: Is that [having a family history in Belgium] an important thing for you?

P15: I think so, because that's your roots. It's where you, you come from. There's so many family stories. There's stories from my Flemish grandmother. She and her sister were nurses in the First World War. [Shares several family stories] There's all the sorts of stories like that, and you think, that's your heritage. That's in the end what makes you (.) makes *you*. I like to walk down the road and think that my Flemish great-grandmother walked down here, knew this shop [provides other descriptions] and I can think, "My grandfather built that".

This connection to the places appears to come both from the lineage she has there, and the resultant sense of origin and belonging, but also from the memories the place holds – both personal and familial. These types of accounts are frequently echoed by other participants therefore these processes of memory and remembering are the subject of the next two themes.

Theme 2: Storied Places

Interviewees frequently describe places from their past by giving accounts of their significant memories, which are triggered by these places. This theme labelled ‘Storied Places’ was exceptionally prevalent in the accounts of participants, but it should be noted that remembering was not always experienced as a positive thing. In each instance the places seemed to function to link people to earlier times in their personal or social history through memories recounted in the form of stories. Frequently this connection between place and memories was used to justify place attachments. Participant P1 below described her attachment to Crete in this way, for example.

P1: Ehm, (.)I always miss these times, ehm, it’s more in, ehm, (.) intense, when I am in Crete and I go to places and I see something, a place for example, where I was 10 years ago and I say to myself oh that’s the place where I fell in (.)10 years ago, and I cried and...

P1: It’s where you grow up, you remember yourself doing things, you remember yourself going to school (...) my memories come from this island. I miss very much these times, these years, back then, and I wish that I had a time machine to go back.

Later she describes how she thinks of these childhood places whilst living far away in Scotland, describing the complexity of the feelings she comments: “...it’s both missing it and reliving it”: an idea that ties in nicely with Milligan’s (1998) notion of places as mnemonic devices involved in processes of nostalgia helping to create a sense of continuity.

Participant P2 describes below how a village he spent time in during his youth triggers memories of his childhood experiences when justifying his feelings about wanting to buy a house there when he is older, despite the expensive house prices.

I: So you'd move back to [town name] if you could?

P2: Oh I certainly would, definitely.

I: Oh I see.

P2: I think that I had a lot of happy times when I was there, like building dens, out on bikes. It's a very safe place.

I: And what do you think...so you think about those times often?

P2: Yeah

I: When in particular?

P2: When I'm passing through and I see a tree I used to climb or something.

Here he makes reference to the ways the place stories are connected to others, and confirms that the places help him to remember the people themselves, as well as the experiences in place.

I: So there are significant places?

P2: Yes.

I: Can you tell me about one of them?

P2: Just places where we used to build dens and that, and have a laugh.

I: Places where you played?

P2: Aye.

I: Do you think it's something about it reminding you about the people you shared those times with or is it more of a personal 'all about me' sort of thing?

P2: No, I think it's quite social. The fact that some of my friends, some of the friends I spent a lot of times with, it's good to remember them (...) cos like, one of them (.) he's dead now so...

This story-based account of places as triggering memories from the past is also expressed below by participant P15 when describing why she likes to go back to visit places from her home town, although it is located in the south of England.

I: Why do you do that? What do you think?

P15: To just remember happy times. I had a very happy childhood and again, (.) uhm, family, who are always there. I mean we used to go to my grandmother's, eh, every week, if not, you know, more. Go out to see Gran. And I can remember as a kid, you always fall out with your parents, you know, and I remember thinking if I was in trouble, I would always run away to my Gran's (laughs).

Similarly P18 uses the contrast between places that can trigger memories and those that cannot to explain why she is so connected to Edinburgh.

P18: You can look at a pretty loch and think that's lovely but it's not going to stick in your mind for long. I've been up in Edinburgh on the castle esplanade at 3 o'clock in the morning after a rowdy party there, ehm,(.) you know, (.) the Canongate is far more of a memory than, "Oh that's just a nice castle esplanade".

Theme 3: Storehouses of Memory

In a similar fashion, people often orient to places from their past with a sense that those places somehow 'hold' memories. This is a somewhat less active remembering-based or 'trigger' type account of place. Instead it is more characterised by places as storehouses of memories, and it involves a notion of places as safeguarding this aspect of self. In some cases, the distinction between the triggering of memories in place and the role of places as a store of memories is clear because the place no longer exists. One of the most unusual accounts like this came from participant P20 who saw her parents', now scrapped, caravan 'The Enterprise' as the storehouse of her childhood memories, because her parents were travelling entertainers. However, the distinctions between storing and triggering functions of place are often hard to separate and articulate, though. This is evident in P12's account of significant places:

P12: So there's no, you know, places (.) It's not, it's not some sort of (.) *empty* place. Ehm it's like there's- You know there's a place jammed between, yourself remembering that place and what is in that place. And eh, you kind of eh (.) whatever situation you can remember.

However, participant P1 summarises the storehouse idea clearly here, saying, "It's just such a place which holds happy memories to me. It's very dear to me." This housing of memory becomes more apparent in sequences that involve confrontation of place changes. An example of this is expressed by P1, who firstly describes her school in Crete, and then later describes how it felt when she later visited and found it had been demolished.

P1: Well I pass from there and I think "oh here was my school and look at how different it is now" (...) and I felt really bad when I was passing from there and there was nothing before building it again. There was just the land.

I: What do you think made that feel bad?

P1: Ehm, (.) I felt that someone had destroyed my past.

Interestingly, she later gives an account of how she recovered from those emotions by trying to think of the memories that the place encapsulated. This excerpt shows the close link between the place as holding memory, and the active memory work that can be done to reinstate it when needed.

P1: I was always bringing the image of my school and the faces of my classmates, I was thinking, that's *my* school and automatically I start thinking (.) of my teachers, my school mates and all the, the funny and the pleasant moments we had.

She later describes the relief she felt when she discovered on a subsequent trip that a new school had been built on the site of the old one. When pressed on why this is good she stated, "It's a different building but it's still my school", indicating that having a building there that represents her school, the physicality of the building, helps with that holding of memories.

The idea of places housing memory in a somewhat fixed manner is typically identified by those who also express strong place identification as a positive thing, and the fixity of the place can be positive for a number of reasons. One common way this was expressed is in relation to a sense of familiarity and predictability that this connection with memory provides. One participant describes being in these places as “Like putting on an old overcoat.” This notion is expressed with some more details in the following account by P2 describing his most significant childhood place.

P2: [*Village A*] always feels like home, it feels a lot more comfortable and that, because places like [*Town A*] and [*Town B*] change quite dynamically, whereas [*Village A*] is stuck in a little time warp. It feels very comfortable. You’re not going to be surprised by anything

I: Is that like a safety thing?

P2: No, I wouldn’t say safety, you just, you just don’t have to expect the unexpected.

Later he brings this topic up again whilst explaining why he did not move away when he had the chance in his twenties, a time when he felt he needed ‘stability’.

I: Would staying in one place give you that stability?

P2: (...) It’s that word again, ‘familiarity’.

I: Do you think familiarity is to do with the people or the surroundings, or a combination?

P2: I think a lot of it is what you are used to. I’ve been to quite a lot of places in the world and I’ve always enjoyed myself, or I’ve been away and thought I wished I was back home or back in a more familiar settings, but it’s just that it’s very easy to be familiar with things.

Interestingly, this memory is sometimes explicitly linked to events beyond the lifetime of the person, and the perceived continuity is therefore mediated by the collective associated with the places rather than the direct experiences of the interviewee. P6 uses this

connection between people and events from the past to justify his preference for places with a sense of heritage, which he suggests is salient when a place represents a proud collective history.

I: How do places like that, even a town centre for example, how do they play a part in that sense of belonging? Sense of where you are going?

P4: It's not the battle field itself, I'll use that as an example, its people's attitude about the battle. It's their pride that the battle took place there. [*Goes on to describe how this relates to actions of people in the past*]

I: It's what happened there that is the link to the people? It is the people from the past that were in place, rather than the place itself which forms that sense of heritage?

P4: Yeah, unless I mean, the only reason I can think where people would say I'm pleased I'm proud of being from [a place without heritage] is if there is a huge landmark there. A natural formation.

I: Still you feel, I'm just going back to Corby and why it's not attractive to you. Still you think somewhere you would seek out, would be somewhere that has that sense of heritage over somewhere that doesn't?

P4: Yeah, certainly be more attractive to me. I would say (...) Peterborough is quite a classic example. Yes it's a new town, it's got the housing estates as far as the eye can see, but it's got two queens buried in the cathedral church yard.

Later he discussed how this links to the human propensity to seek preservation, linking it specifically with the maintenance of identity.

I: Why do you think people want to do that, why do you think they want to preserve?

P4: It's to do with history [...] since then we have become more and more interested in history it has helped create, I think, identities about what happened in the past.

Participant P16 echoes this human propensity to seek heritage and continuity with the past whilst discussing why he thinks people from other countries come to Scotland in search of history and ancestry.

P16: If you can see traces all the way back you feel (.) it's more like home [unclear] if you've got a constant path or constant reminders of the past. People in America, because they can see like the (.) past, they can only go back like 200 years, it confuses the shit out of them because (...) they dinnae feel like (.) they belong. They're always... [I: Sure] So they come over here and they just love St. Andrews and they love the, the heritage.

Theme 4: Broken Past

The difficulty of losing a sense of connection with past self through the loss of an important place is another prominent reflection of perceived referent continuity within the interviews. This is found in the excerpt below where P10 discussed rediscovering the main street in the suburb where she grew up upon her return from England many years later.

P10: I try to remember what it used to look like...but I just don't feel that it's the same...I just don't feel at home. I felt no relationship at all with it.

In contrast to this experience, she later described how she progressed on her walk during this visit to find her old church, which had retained its identity.

P10: I was very happy to go in and see the church. If you go back to a place it makes you think of a time before, and what you were like in that time, and in that place (...) I was happiest in my walk when I saw that place that had stayed the same.

Several other participants also described the impact of place change throughout their lifetime. Describing going back to a very early childhood home on a visit with his mother, participant P8 described how he felt when discovering quite significant change in the garden and house

they used to live in. He reasoned, “I guess probably everybody feels this, like the past is past (.) and that’s kind of tough to see that gone”. He was clear to express this place is not the place from his childhood that he considers home, and he does not feel this is a particularly problematic issue for him, evident in the ‘kinda’. He viewed it as somewhat to be expected, but nonetheless it is experienced with displeasure.

Participant P6 also describes a break in continuity with a past place but in a different way. For her the break was a desirable thing because the memories the place held were negative. In the following excerpts she describes her need to leave her childhood home in Newcastle and her decision to seek a ‘home’ in the army after returning from a brief spell working in Spain as a teenager.

P6: I think I was looking for a home and I felt I would be safe and ehm, (.) how should I put it (.)°My father was a strict man°. And we all left home pretty early and ehm, and of course between that and ehm the experience in Spain. I think I was really looking for somewhere safe.

I: Uhuh. So you weren’t pleased to be back to Newcastle then?

P6: (.) In, in a way because my brother and sister were there, and, and Newcastle will always be special, but I don’t suppose I consider it my home. It’s just somewhere I go back to visit.

Interestingly though, her feelings and the valence of her memories change according to the specificity of the place. For example, in the next excerpt she recounts feeling sad about the fields around her house changing, and later admits she would be happy to move back and retire to a neighbouring town that she used to frequent in her youth.

I: When you go back then to Newcastle are things the way they were when you grew up there?

P6: Oh, no! I suppose that... Oh God I sound so old! When my dad was taken ill and he had to go into a nursing home and I went home for the first time in

like about 30 years I couldn't believe how small it was. And it was (.) it was really °uncomfortable°, the old house. And I didn't like that. It wasn't as I'd remembered. And it was very uncomfortable, and too sad, too many memories. I didn't like that. (.) And it is frightening because I'd say to [partner's name] come on let's have a walk down and I'll show you this place, it was great, and then it's gone! The trees, the fields...

However, the memories of the house itself are too strong for her to have wanted to visit during her lifetime, as is evidenced in the following excerpt.

I: So when you went back to your home [*after her father had died*] it was a really long time since you'd been there?

P6: Yeah.

I: Do you think when you went there and it was different [*summarises earlier account*] was that sort of saddening in that similar way as when you went to places and the trees were down and all that?

P6: Yeah, it was and the circumstances as well it was (.) you look back and you think, it really is sad (.) We could have had such a nice life and instead we had this awful life [*goes on to describe details about her family life*]. I think it helped a bit though that it wasn't exactly the same. I was scared to go. I was really scared to go!

These two examples have shown that for some people a break in the past is problematic because it represents a break in link with memory (both as trigger and storehouse), developmental experiences, and the sense of belonging. However, they have also indicated that a break in PRC can be useful, and deliberately chosen in some circumstances, especially where these memories are undesirable or disturbing.

Theme 5: The Contingency of Place

A notion commonly related to the idea of strong identification with a place that arose in some interviews was a feeling that places were somehow destined to be part of the person in

some way. This idea was commonly expressed when people attempted to explain why they felt attached to some places and not others. For example, in P15's account of her attachment to Bournemouth, and not her current home for the last 30 years in Dundee, she comments:

P15: I don't relate so much to the home, the *place* (*corrects herself*). I mean don't get me wrong, I think Dundee is great, you know, but it's by sheer chance that my husband chose to come here. We nearly went down south, we nearly went to Exeter. I probably would have felt the same way about Exeter. So it's really been contingent upon other things, Dundee.

This theme seems to relate to a dichotomy in places as either fixed and predestined in some way, or arbitrary and random. In the first instance places seem to feel predestined if they are related to either a long family history (as in the origin theme), or are related to some formative developmental stage of the individual. Participant P12 describes it as the difference between places he feels are more fixed in his life story and those that are more transient. On the other hand, they seem to be linked with a sense of randomness if the place is deemed less important to the participant's formative experiences. In this situation the participants feel the place is contingent upon other factors; commonly those that are concerned with the congruency dimension of place identity continuity. This is evidenced in P8's account of why he is attached to his second childhood home in Canada, more than any other place he has lived in Canada or Europe – places he describes as feeling merely “incidental”.

I: What do you think makes it significant then?

P8: Hmm (...) well (...) I think for my, I think my house is the best example. The place I grew up in, in Calgary, because that's the place more than any other place, I feel the most (.) that possessiveness towards and eh, yeah I mean identity (.). Yeah that's the closest I would say to that house is part of my identity (.) growing up there is part of who I am. And I think that has a lot to do with, uhm, with my family. I guess everything else feels kind of random

[*describes residential history*] the place just sort of, that's the way it came about. You know, Dundee just happened to be the university that I got into, and that was the cheapest so I said, "Okay, I'll go to Dundee". Whereas Calgary, I mean it doesn't feel random, anymore [...] it feels important, it feels significant.

Place Congruent Continuity

Theme 1: My Type of Place

Of course, there is an element of suitability in the decisions made about connections to places, which might not be captured in the previous accounts. This suitability of fit of a place is related to the provision of congruent continuity. The first theme interpreted from the interview data representing place congruent continuity corresponds closely with Feldman's (1990) settlement identity ideas. That is, that people see themselves as being a person who prefers particular types of environments, or 'settlements' in Feldman's terminology. For many participants this is defined by preference for rural or city places. Participant P8 described how he doesn't have a particular place in mind for his future, but that he knows it will be a city, as he sees himself as a "city person".

P8: For me I would say I am more like one of the people who doesn't have an idea, but you know I spend far too much time messing around on Google, checking out places that I would like to go and (...) I mean I love cities [*describes his friend's rural preferences*]. I grew up in a big city and I love big cities, I miss big cities and every time I go to one, like when I go to London (...) I just love it.

For others it is more specific place features that are important. P1 for example, sees being by the sea as a crucial place feature for her, a feature she "connects with". She commented on how it has made her feel better during her time away from Crete when she has

been able to be near the water. In Dundee she has found a house near the Tay Estuary, which she reported are being “comforting”. Below she discusses her time studying in France and why she likes places by the sea.

P1: In France I wasn't near the sea, unfortunately. And (.) ehm, I missed, I missed, it was what I was missing very much. But I don't think I could live my life away from the sea.

I: And has that got something to do with Crete itself, with growing up near the sea?

P1: Yeah. It comes from the water, hearing the water, seeing the water (.) that's all.

Importantly, these accounts differ in one aspect, which is whether or not this congruency is associated with an on-going search for congruent continuity that is not at all place specific, or whether it will later be followed by a return to an already suitable home. For example, in P1's account she considered Crete to hold “the most basic characteristics that I consider essential for a place to have just to say I can live here for the rest of my life”. This issue will be discussed again in accordance with place future continuity, but it is important to note that the difference between these types of accounts seems to be the expressed level of attachment and identification with interviewees' places of origin, or that place considered their ‘home’.

Theme 2: Lost Congruency

One way that place congruent continuity is evident in the interviewees' accounts is in relation to a lost sense of congruency with a place due to its change. This is evident in the account given by participant P4 when he described what the town of Corby was like when he grew up. He describes the town as a ‘steel town’ as the steel industry was a defining feature of the place when he was growing up, until the 1980s when the company collapses there.

When asked if he would like to return, he referred to the decline of the town and its resultant unsuitability for him became apparent, especially in his final qualification – which he expressed with some sadness: that places should progress positively, not negatively.

I: Ever feel like you wanted to go back there?

P4: No. Me mum still lives there, and my eldest brother still lives there. But you still hear about things that are going on. The town's got bigger, it hasn't got better, em, the thing we noticed, I noticed when I was growing up, no one got murdered in Corby, a lot of, pretty hard town, but I can never remember when I was growing up people getting killed. In the last 10 years, must be about ten people been killed. And of course, my father died last year. Went back for the funeral and got talking about the town, and all that sort of thing, and there was just no way (...) sad (.) sad thing to say.

I: Why do you think it's sad?

P4: Eh, well as we move on things are supposed to get better, not worse

On being asked to elaborate on why he would not go back, he goes on to explain the place's change, which has created its unsuitability for him. He explains that the town had "new town" status in the 1950s, when new industry created a lot of new jobs, but concedes this once important identity is now lost.

P4: The identity when I was growing up in Corby was the steel works, that's what made Corby different, the steel works and having the mine down the road, an' that sort of thing, gave it an identity. The last 20 years it has tried to develop a new one and that's just because (unclear), and part of the location. I do think when the steel works, and that was around in the 1980s, that was what made Corby different. Twelve thousand people worked there and now it's down to six thousand. And then in 1981 it was just another town with massive unemployment (...) we were a black spot.

These concerns over change in suitability is echoed by participant P9, who moved away from his hometown to seek excitement and opportunity in London but later realised how

unsuitable it had become for him; a change he associates both with his age and his perceptions of city people.

P9: I reached the age of thirty and then the whole city thing started to get a bit wearing and I kind of found, I found myself getting more and more annoyed with people that lived in the cities, really, really, rude and when I say that, even if you come to Dundee, compared to [town] city people are extremely rude. Erm, (.) and I just couldn't cope with it anymore ((laughing)). Even Dundee on a Saturday is quite difficult for me to cope with now and that's, you know, I used to be bombing around Oxford Street and Soho.

Indeed this sense of places becoming unsuitable as people develop and change is quite common, and as such featured in many of the interviews. This unsuitability and the challenge to congruent continuity often does not appear to come as too much of a surprise to the individual because of their own perceived change, especially if they feel no longer attached to that place. Participant P11 simply comments for example, "When I did come back occasionally, just to visit that place, I also suddenly found that it's (.) I've become too big for it, both mentally and physically".

Theme 3: The Risk to Me

The accounts given by both P4 and P9 are about place change, but both accounts also show evidence of the next theme, which is less about a change in place causing incongruence and more about the fear of the place potentially changing the participant. P4 discusses the lifestyle that his new place(s) can afford him in terms of opportunity, employment, and lifestyle and how this contrasts with what his hometown of Corby could offer him.

P4: I didn't actually join the army until I was 23, so I think these are all kind of ideas from when you're younger, don't you?

I: What kind of ideas?

P4: To belong to somewhere, an area. I couldn't see any, when I've heard this from other people who live there [...] If you stay there beyond a certain age, you're going to stay there your whole life, which is probably the same for a lot of other places. Emm, so at 23, I was like "That's it I'm off", that's why I've never lived in Corby ever since.

I: What do you think was the main factor for you in not wanting to be somebody who stayed there, their whole life potentially?

P4: Eh, em (...) I couldn't see it was somewhere where I would advance, or grow, or expand myself. [I: Right] I could get a job quite easily as it turned out, and I would be doing that job for 10 years. And I would be doing the same thing every day for 10 years. I just didn't want to do that. [...] It was like being a mouse on the wheel.

This motivated a move to the army, and to places that offered him the "chance to do different things, which I never would have had the chance if I had stayed in Corby". P9 also describes the risks he felt he faced if he had stayed in London and not moved back to Scotland. This risk is very much associated with the culture of the place and how he sees it as having affected the actions of the people who remain there.

I: So nothing that particularly changed apart from that you kinda had enough?

P9: Yeah. Yeah, definitely. Although in saying that London's changed a lot but I don't (.) it's difficult to know whether it's my perception of it that's changed or whether London itself has changed. I think it has. It's definitely busier and dirtier and there's more people. Erm (.) and it gets continually more violent, but then again it's difficult to tell whether that's really what's happening or whether as I'm getting older you become more sensitive to these things. I think maybe your self-preservation instinct kicks in, and you start to think, "I don't want to be around this, it's dangerous".

Participant P13 described a similar survival concern as his explanation for leaving home and going to the army. In his case he described the rough area of Dundee that he grew up in and how his teenage friends progressed from alcohol to harder drugs, until eventually a

close friend died. At this point his hometown became so incongruent with him and his plans that he felt he had to leave his family and go. His reflections on this move illustrate this risk felt in relation to incongruence between self and place:

P13: You know (.) so (.) that side of life you're thinking (.) If I stayed in Dundee, I don't know (...) if I hadn't joined the army I don't know what would have happened.

For others the risk is just associated with becoming the kind of person who is stuck in one place. As in this final account by P12 on why he needed to leave his hometown:

P12: Well, I just think it's, think it's important to like see other places and eh, not to be too (...) because, I just, I don't, I don't really like the idea of eh, becoming too comfortable with a place.

Theme 4: This Place Fits

Perhaps the most straightforward demonstration of the impact of place congruency on place identifications, and often by extension residential behaviour, comes with the notion that a person's life should be mediated by a fit between the place and the self. This differs from a notion of place type expressed in the 'My Type of Place' theme, as it constitutes a much more fluid idea of fit that seems to vary significantly across phases of people's narratives. This contrasts with settlement-type identities, which are commonly more fixed interpretations of self. It is also more associated with seeking something more 'ideal' rather than escaping something dangerous or negative. Participant P1 states this simply whilst explaining why she has moved around:

I: And [*after your studies*] did you go back to Athens or back to Crete?

P1: Athens. Because it's the capital and the opportunities are there.

I: Do you think if there were opportunities in Crete you would have gone back there.

P1: Maybe I would have gone, I don't know. And it was difficult to find a job that I liked so I decided to continue my studies, and that's why I'm here.

She later goes on to describe how it is the specific features of Crete that will lead to her eventual return to Crete; again demonstrating how place features impact upon the maintenance of congruent continuity.

P1: It's the kind, the way of living (...) ehm, it's ehm, the environment. Ehm life is more relaxed there, (.) ehm it's near the sea. It's very important for me, ehm (...) It's mostly because it's, ehm, life is more relaxed there (.)The day passes more slowly...

Participant P15 also provides a good demonstration of how residential history can be mediated by the needs of other people, in her case to suit her husband's employment needs.

P15: So it was really his job and then it was his job that brought us to Dundee.

I: So would you say you've moved around quite a lot due to work then, rather than choice?

P15: Yes, before I was married, for my choice but then after I was married, well you go where the job is don't you? Well, I did, but some people don't ((laughs)).

She later describes how her residency has more recently been regulated in part by being close to her grown-up children, just as it had been for her mother. What is important to note in this account though, is that she does not report considering any of these contingent places as home. In fact, she declares her Bournemouth residence as "always" home to her, despite not living there since very early adulthood. Similarly, in P4's account, his moving for work (and planned continuation of staying away) comes in conjunction with little self-reported attachment to home. This indicates that whilst place congruent continuity is one way that places can provide a sense of continuity of self, this continuity is not necessarily associated with place identity per se. The importance of these issues and how they impact on future

plans and place identity are elaborated on when examining themes relating to place future continuity below.

Future Continuity

Theme 1: The Need for Preservation

The idea of preservation, or more accurately conservation, was evident in relation to place referent continuity. However, to some extent it was also evident when people were orientated towards maintaining place identities for the future, rather than just maintaining the link between past and present. One good example of this is in participant P10's account of her feelings about the church she frequented as a child, and has now found again. She suggested that although she does not like the modernisation, she knows that if the place does not adapt to suit future generations it will not continue; this continuation is felt as inherently valuable to P10.

P10: Part of me wants it to be the same, but we're all going to die off and the church will have nobody so if we keep things the same then it will die too so there has to be change

Participant P15 also describes the idea of preserving place for future generations, but this time in connection with place-related stories and family memories, rather than the physicality and use of place for future generations. She explains why she thinks it is important to pass these details on to her grandchildren, below.

I: And why do you think that's an important thing to have?

P15: Yes, about where you come in the line...and probably where you are going. [*Discusses past places briefly*] I feel very strongly about that because I remember my grandmother and all the stories, and that's why I tell my grandchildren stories. I think I'm laying down what was laid down for me

because they will carry that on. And they want to know, they want to know, who and where did they live and what did they do.

It is clear in this account that the interviewee feels the continuity of the place identification should be preserved for her family – stating that it is this “family folklore” that knits future and past generation together – and she feels a responsibility towards this end. Literature that looks at the need to gain family integrity in older age (e.g., King & Wynne, 2004) would suggest this might be associated with this particular participant’s age (61 years). Regardless of the cause, this finding provides a good indication that people seek to continue place identifications in the future, and even consider this important beyond the limits of their own life-span.

Theme 2: Projected Congruency

The idea that places can be used to manage an on-going sense of self is closely connected with the function of place congruent continuity, discussed earlier. This maintenance of congruent continuity is also evident in people’s accounts of where they would like to go, therefore providing evidence of a projected sense of self in connection to places. This is apparent in P2’s account below where he explains what it would be like not to be able to fulfil his dream of settling down in his home town.

P2: That would just be life, and I’m sure there are other places. Although [town name] is a special place I don’t doubt there would be a place that would have an even bigger meaning for me

I: And what sort of features would a place like that have to have?

P2: Probably a small square, one road in, one road out ((laughs))

I: Something reminiscent of [town name]?

P2: Yeah ((laughs))

Here, participant P2 unexpectedly described this future place as completely identical to his place of origin, providing some amusement. As was mentioned earlier in line with place congruent continuity, this finding demonstrated that place future continuity can be derived not just from a future return to places from the past, but also can be fulfilled by a place with the features associated with what feels like appropriate self-development. For example, for participant P8 this means seeking a city environment, but not necessarily the one he originated in.

P8: What I keep saying is I want to go to a world class city. That's like London, Toronto, Montreal in Canada or uhm (.) Paris or someplace like that [...] But the truth is I don't really care. As long as I have a job I can stand and (girlfriend's name) is happy there (.) and it's gotta be in a big-ish city (.) but other than that I'm not that picky.

For some participants the congruency of place sought for the future was much more about the nature of the emotional relationship with place. For example, P19 describes the sense of attachment he felt to his grandparents' farm, which offered him the comfort his "unsettled" home life could not.

P19: I just felt it was kind of- everything was kind of more real (or something) there. So I'd like to (.) I'd like to create that for myself.

For other participants future congruency seems to be realised through movement from place to place, rather than specific place features. This is quite different to earlier accounts, but still involves relationships between places and self in terms of planning for a maintained sense of congruency. The following example was related by participant P7, who described a need to travel as being consonant with her views about places and her own autonomy; a characteristic that she feels results from her experiences of disability and immobility in her childhood.

P7: I'm autonomous. I like autonomy [*describes her desire to enter the Wrens so she could travel*]. I knew that if I went to Derby I would get to London, and from London you would get abroad.

I: Right, I see, so it was all a big plan?

P7: Well, I mean it was pot luck as well, it's pot luck. I thought well that's a better way to do it because people I had become friendly with were quite happy to stay where they are and I thought "No, I don't like this." (.) So that started me on going places.

Later she describes how it felt not to be able to do this once she had her son and was located more permanently in Dundee with a stable job.

I: And how did you feel about the, being in the same place for all that time?

P7: I was unsettled, because you felt like you needed to get up and go somewhere you know, and I really mean it. You know, maybe a year down the line you felt like "Oh I have to go somewhere".

I: And why do you think you, what do you think it was that drove you to feel like you wanted to travel? Or move on is maybe a better word for it.

P7: Move on from where I was?

I: Yeah.

P7: I felt I was capable of doing with a lot more.

Several young people also described this idea of a projected future characterised much more by *movement* between places rather than being suited to one place or seeking out specific place features. Participant P14, for example, described her gap year trip to Africa as "shaping everything I see for my future". She elaborated on this before describing her travel plans for the future. The following excerpt demonstrates how these plans are mediated by a sense of incongruence between her and her peers in the Perthshire town of her birth.

P14: I was like (.) I didn't want to come home (.) I don't want to stay like back at home and stuff (...) like (.) I want to be independent.

I: Is that quite different to the way you'd felt before then?

P14: No I'd always, like even though (.) I would say I've always (.) I've... I do have a very supportive family. I've always wanted to get out of [town name] (.) because (...) I didn't, I don't hang about with anybody there, and I didn't like really (...) my friends or my peer group from [town name] were into like a lot of different things that I wasn't. [I: Mhmm] And they seemed to quite, they thought that [town name] was like the be all and end all.

I: Mmm

P14: Like they couldn't see that you know (.) there's different things out there [...]. And I'd never ever wanted to be like them so I made it a point I think to get away as far as possible.

I just, I don't think I'll ever settle down in one place I think (.) I want to be like (...) always in different places.

Theme 3: The Certain Return to Base

One of the most common ways that interviewees referred to their future place relationships was with the idea of residential reconnection to important places. For some participants this place (often a place of origin) was considered as a base, and therefore was wrapped up in a notion of certain return at some later point in later life. Participant P12 used this word 'base' in relation to his current home, saying, "Dundee is more of a sort of a base (.) is more of a home for me because, eh, it's kind of *my* place". Participant P18 invokes the idea of returning from "exile" to her hometown after being taken away from it as a child saying, "I think because I always saw Edinburgh as my home, and I was sort of in exile, and obviously went back there as soon as I had some autonomy". For young participants especially, like P1, this idea of a return to base is commonly referred in to in a future-oriented fashion with the notion of a distant but expected return.

P1: It's the place that I always want to return to. I want to go and live there for the rest of my life.

I: And do you often go back and visit Crete?

P1: Yeah, yeah, I went in Christmas, because it's my family there. It's the place I always want to return I want to live there for the rest of my life.

She later reasons that even if a place had all the characteristics she associated with her ideal place (therefore satisfying place congruent continuity), the return to her place of birth would still be of primary importance.

P1: I always liked exotic islands. I call them "the paradise" (.) even if we moved to paradise I will always, ehm, miss the place where I was born. I would be miserable if I knew I would not be able to return back.

The notion of a base is not just associated with a later life stage, for some it is important to always have even when just travelling, and it is often mediated by the place's connection with significant people, such as family members. This is apparent in P4's accounts of how he feels about the travel he engaged in a lot during his army days, and how he would now approach it.

P4: Passed the age of where I want to travel extensively. If I want to travel now it would be for enjoyment. If I travelled it would also be to come back to a base. Say we stayed in [town name] then I would work in Aberdeen or Glasgow but always come back to [town name], or wherever our base is.

I: Is that through personal preference or something you would need to have responsibility wise? [P4: What the..?] Coming back to a base all the time?

P4: Oh right, both. Now that I'm enjoying, I got married late and had children late. You want to go back to where your family is.

I: And is that something which changed as you got older, that feeling of wanting to come back to one base?

P4: Not really. No, it's just kinda came with family. Yeah, even in the army you're always coming back to your own barracks. Even in Iraq, I was still coming back to my own barrack. It's just something I've grown up with and got used to. I had quite a stable family background growing up; it was just something I got used to.

In these accounts the place itself is often bound up with notions of permanency and fundamental availability to the individual. This means the place is often considered fixed and immune to change. Participant P3 elaborates on this below whilst giving an account of her plans to move around after university before returning to ‘base’.

P3: These places are like stepping stones, but Dumfries is my base. It’s always going to be a base (.) I grew up there, it’s what I know and it’s predictable and safe [...] It’s always going to be there for me (...) I think that knowledge is fundamental, and it’s what makes me so stable.

These future projections can prove problematic, however. Specifically, when the return takes place and there is no place waiting. This challenges what Taylor (2010) has referred to as the ‘pull of narrative closure’, which is challenged in circumstances of place change. For some though, the return is never made because of the feared inevitability of change and instead continuity is only realised through memory and perceived referent continuity. P19 sums this up as he makes his case for not considering a return to his home when his studies are complete.

P19: Maybe it’s better if I don’t go back.

I: Why?

P19: Just because I have some good memories and (.) why would I want to, ehm (.) My dad told me when he went back to the house he grew up in it was a really horrible experience for him because he had all these great memories about that place, and then when he went back it was nothing like he remembered. (.) So...

Yet for some, it is this anticipated future return that has helped them deal with incongruent places in the past. In the excerpt below, participant P10 exhibits a response of this sort when describing how she reconciled her feelings with having to leave Dundee after her marriage due to her husband’s new job.

P10: The only thing that I know is I am coming back to Dundee...there is no way I am there for life, and because I knew that I could put up with living in that immense built-up area.

This indicates that even the imagined future return can provide a beneficial sense of place future continuity, and also demonstrates both the existence and significance of these future-related perspectives for place identities.

Theme 4: Place as Survival.

The last theme in participant's accounts relating places to the self in terms of forward planning, is bound up with the notion of survival of the self. It occurs in only two of the interviews but is expressed quite clearly as a link between the person, in terms of bodily survival, and the continuing identity of the place. Extending from her account described above, P10 described how it felt when her future plans of reconnection with her home suburb were not realised because of the drastic place change, she says:

P10: I try to remember what it used to look like...but I just don't feel that it's the same...I just don't feel at home. I felt no relationship at all with it.

P10: It is like a wound, and nobody likes being wounded.

This connection between self and place experienced as some kind of existential connection is also expressed by participant P6 when describing how the change in significant places in her life, can make her consider her own mortality.

P6: When we were brought up, there was literally farmland all around us and now it's just motorways and housing estates and I find that (...) very sad (...) That's sort of sad for the world, but it's sad for me because it scares the pants out of me. Because inside I only feel 16, but when you see something like that you think well your life is just ((clicks fingers)) and it's gone. And pretty soon it'll be gone.

The preceding sections have described the identification of all three predicted place identity continuity dimensions in interviewees' accounts and the subthemes associated with each. The final main category, primary, and secondary codes created are displayed graphically in Figure 5.1 below by way of summary.

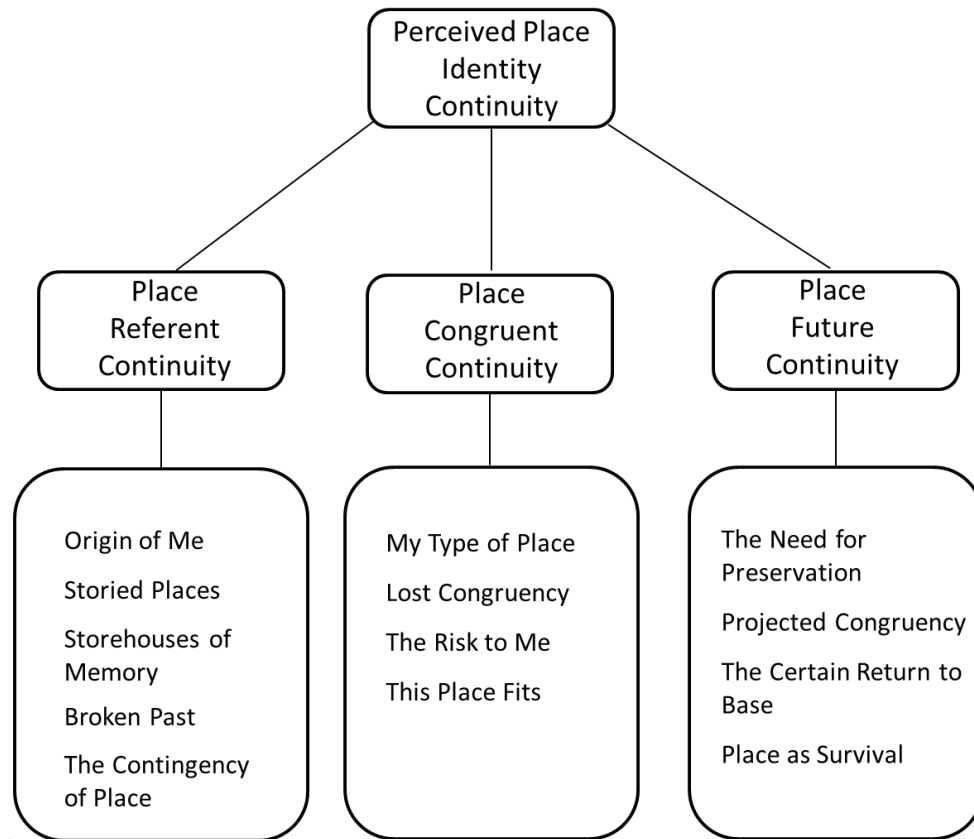

Figure 5.1 Categories and Sub-Categories of Place Identity Continuity Themes

Part 2: Inductive Coding for Place Identity Continuity Themes

The second part of the analytic process involved searching the interview accounts for additional themes relevant to place identity continuity. The accounts provided, due to their inherently narrative structure, vary widely across participants. Just as in previous studies of this type, each interview reflects the rich tapestry of place relationships featuring in individuals' lives. Analysis proceeded following the guidelines provided by Braun and

Clarke (2006) and largely underpinned by Boyatzis' (1998) stage model of inductive coding. This involves first seeing a pattern in responses – “capturing the codable moment” (Boyatzis, 1998, p.4) – before recording and classifying it and giving it a meaningful label. The final stage is interpreting that pattern. Using this procedure three main themes were interpreted from the data corpus: i) the intertwining of place identity continuity dimensions; ii) the importance of place identification, and iii) the contextuality of place identity continuity. Each of these themes will be elaborated on in the remainder of this chapter.

Theme 1: The Intertwining of Dimensions

The first theme related to the observed connections between place identity continuity dimensions. At several points in the analysis of themes relating to each dimension the connections between them become apparent. For example, themes relating to place congruent continuity can clearly be seen to relate to those in place future continuity because interviewees' views of the fit between themselves and the places they are currently connected to have a direct impact on whether it is a place identity they are likely to retain in the future. There are also connections between places from an individual's past, such as their place of origin, and their feelings about being connected to it in the future – whether that be in terms of residency, emotional bond, or preservation for future generations. Participant P6, for example, claims she would not go back to Newcastle because of the bad memories it brings, but later claims she would consider nearby Hexham.

I: Would you ever consider making that house and that family home down in Newcastle, where you could be near your brothers and sisters?

P6: My family is here. But I miss my brother and sister. (.) Oh that's a nasty question. (...) Not in Newcastle. Hexham, we'd live in Hexham, yes, because

it's so beautiful and I don't think I could resist that (...) I really don't think I could resist it.

I: But if you had the choice you'd rather do it up here?

P6: I'd go to St Andrews before I went to Hexham. Yeah, but if somebody said to me there's a house in Hexham...

I: And would that just be for the aesthetic reasons? You know, the way the town is and it's nice?

P6: Yeah and it's part of my, it's part of my childhood. We used to go to the dances in Hexham (.) when I was a teenager. (.)And it's a nice little place.

So whilst for the purposes of in-depth analysis and theoretical development these themes have been analysed independently, the inherent connections between them, in some instances, cannot be ignored. Whilst this intertwining is usually interpreted from the accounts people give and their plans for the future, the connection between past and future dimensions is sometime *explicitly* stated by interviewees. One such example of this connection comes in the account of participant P4 whilst discussing why heritage is an important factor in his residential choices:

P4: It is the same reason why history is important, because to go forward you have to know where you're coming from [...] it gives you that sense of belonging to a place, it gives you an idea (.) what happened in the past must have a certain option to what will happen in the future. That's why heritage is important.

This linking is also evident in P15's account of why she feels it is important to share memories and stories of the places she and her family lived with her children: "I think I'm laying down what was laid down for me because they will carry that on." It is pertinent to note, however, that for some people whilst places from the past are important, they are not part of the individual's projected future. To some degree the analysis in Part I of this chapter suggest that this process may be mediated by whether that place can provide a sense of place

congruent continuity. For example, in the case of P8 he expresses a relatively strong attachment to his Canadian hometown, but because he feels like a “city-person”, he is seeking out a “world class city” to become his home. The existence of this intertwining of dimensions is important to note for the quantitative analyses that follow in the remaining chapters because it suggests that whilst the relationship between the past and future place identifications is not connected in a determinately linear fashion, the dimensions conceal intrinsic interconnections.

Theme 2: The Importance of Place Identification

A small amount of participants in the study express either very little, or no, significant perceptions of place identity continuity. Some interviewees describe past relationships with particular places in the sense that they have lived in places and found features of them to be desirable, but they do feel any sense of connection to them. Moreover, they are not at all guided by an emotional connection to place when thinking about themselves in the future, and their relationships with the places they currently live are defined only by their suitability to satisfy present concerns such as employment opportunities.

Participant P17, for example, describes her experiences solely in terms of residential shifts that her parents engaged in for work reasons, and following that, moves she has made for her own studies and employment. She does not visit home unless she “has to” and would not consider moving back to her most significant place of origin, describing it as “boring”. She replies simply “No” when asked if she is attached to any place, and “No” when she is asked if any place is associated with particular significant memories. She concludes: “I don’t think I really associate places (.) with this. I mean I can’t think of any particular place that is

somehow special or ...” Similarly she has no particular plans for the type of place she would like to go in the future or to settle down somewhere in particular.

Very little of the research literature has examined this lack of place identity continuity partly due to its focus on the impact of place change and forced relocations, where identification and the desire for continuity is amplified (e.g., Speller, et al., 2002). One approach to these accounts would be to consider them as deviant cases, as is often done in qualitative analysis (Silverman, 2011), but an alternative way to approach this issue is to note what else varies in these accounts. Doing so alludes to the relationship between place identity continuity and place identification strength.

In these interviews it is repeatedly apparent that expressions of place identity continuity are associated with stronger identification with places and with attachment to places. This is perfectly concurrent with theorising on this construct because it is concerned not with perceptions of place continuity in physical terms, but in place *identity* continuity, therefore necessitating some role of the relationship between the person and the place – the identification with the place. This is supported by observations that place congruent continuity in terms of connecting to places that fit the person at that present time, is more associated with lower identification, unless it is to do with finding a place that suits a settlement identity type that the person feels fits them because they identify with a place. In these cases the place type is often reminiscent of the features of their place of origin (see P2’s account in Part 1).

Interestingly, this lack of identification is often seems to be moderated by a sense of fit with the social groups associated with past places; this is primarily the interviewee’s family, but in some interviews it is peer groups. For example, P17’s account is characterised by distant family relationships and when asked if she spends time visiting family places she

states that they “weren’t particularly family-orientated”. This is perhaps more explicit in P7’s account below, which follows her description of some upset in her family, which caused her to leave Dundee. Here she puts forward an explanation of why she thinks seeking new places is important.

P7: No, yeah but I think it's cos my friends had moved and you realised that everybody had moved. And I did say it was quite isolating and that was why. Because you knew, you've got to move forward you can't go back. I think that was it. Things can never be what they were, because you've moved on they've moved on. You have to start where you are, not from where you were.

This is perhaps most evident in the account given by participant A5, though. She describes a current sense of *non-belonging* in Scotland after leaving as a young child to go to England. However she describes a childhood lack of belonging there as she was labelled as Scottish, whilst retaining an English accent was problematic when she later visited Scotland. She also describes a strict catholic upbringing and a very restrictive relationship with her father, partly due to his part as a prominent community figure in the English town they lived in; a position that denied any teenage privacy and brought about an “inhibiting effect”. In the excerpt below she described her experiences post-university; a time when she “got as far away as possible”.

P5: I finished that and then I sort of drifted a bit I suppose and I didn’t want to go back home ah (...) what did I do?

I: And why did you not want to go back home?

P5: Because I’d left home, you know. I was never that ehm, (.) I didn’t have the kind of relationship with my parents that would allow me to go back and as I said they were quite catholic and I wasn’t (.) remotely, by that point in my life.

I: Would you not have moved back and just not moved back in with them then?

P5: Well, all my friends had left Leicester, and I’m not one of those people, at that time certainly, who keeps up with people. I just tended to move on.

She goes on to describe a love for travel that defined most of her adult life, later becoming an EFL (English as a Foreign Language) teacher to fulfil this love. Interestingly, she describes Brighton as one of two places she feels some connection with. She describes some affinity with Brighton due to it being by the coast (reminiscent of the coastal town in Scotland her family come from), but defines the place identification as resulting from a sense of ‘fitting in’ due to the culture there.

P5: There was that attraction to Brighton, it was on the coast and it’s you know it was compact, you could live near where you were going out and it was such a melting pot of people. I don’t think I ever knew anybody who was born there. You know, they’d all got their own stories for coming there and ending up there and ...

I: Do you think that idea of a melting pot of people, who didn’t originate there, did that appeal to you in some way?

P5: I think it did because I suppose that’s where I could say, after all the huge and numerous mistakes I made there, that it was really about being me [talks about her father’s community roles] I’m a lot older now but it still rankles a bit. You know there’s still something about nobody knowing you. I do like the idea of anonymous or you know creating who you are...

I: Do you think that came from those experiences in Leicester?

P5: Probably yes, yes, I’m sure. I can’t think where else it would have come from.

This belonging is also associated with her second reported place attachment: the school camp in Norway where she and her husband taught. Again, she associated this place with a sense of acceptance and fitting in as all the other teachers were also ‘travellers’ and originated from multiple places. She relates this affinity with well-travelled people back to her time in Brighton where she suggests the idea of travel “germinated”. She elaborates on this below:

P5: It was to be part of that group that I suppose I'd got into in Brighton and that was part of your passage and the badge of membership is that people travelled extensively.

This participant clearly identifies herself as a 'traveller' and hence expresses some sense of place congruent continuity realised by travelling through many places, but what is crucial to note is that the two places she identifies with involve a stronger sense of place identification, moderated by fitting in with the people there. More importantly it is only these two places in the many she describes that she expresses any other sense of place identity continuity with. Brighton is connected to an earlier version of self and holds significant formative memories, whereas Norway is the only place she admits wanting to return to in the future.

Of course, there is a danger of becoming overly diagnostic with an approach such as this, but the impact both of social relationships on the propensity to develop place attachments and identification seems ubiquitous and able to either promote or limit the development of significant place identities. What is more evident, is that place identity continuity is unlikely to be expressed where there is little sense of place identity, and perhaps vice versa. The relationship between these perceptions and identity processes remains to be quantitatively explored.

Theme 3: The Contextuality of Place Identity Continuity.

The final prominent theme in the interviews concerns the apparent contextuality of expressed perceptions place identity continuity. Evidence of this contextuality can be seen to some degree across many of the interviews, in the sense that there is normally some variation in people's accounts of their place relationships and how they feel about them in terms of the past and future. However, during some interviews participants can be seen to reject the notion of place attachment and identification all together, often construing themselves as

being interested in travel and experiencing new places. This is usually associated with little desire to maintain connections with places of origin, and hence a lack of place identity continuity. However, for some this is followed by accounts of a desire to re-root themselves when they get older or reach a particular life-stage or developmental milestone. In some accounts therefore, there appears to be shifting levels of place identification across interviews. With this shift comes associated expressions of interest in maintaining identifications, for example, whether a place will be somewhere the interviewee sees as important enough to return to in the future. The account of participant P3 will be used to demonstrate this.

Participant P3 is a young female student who comes from a town in the Scottish Borders. She begins her interview by explaining how she came to be at the University of Dundee due to a desire to get far enough away from home to be independent and escape the “comfort zone” she saw her peers as immersed in. Like participant P14, she has travelled to Africa during her gap year and found it a transformative experience that confirmed her desire to escape her hometown and pursue a “valuable” life defined by travel and work abroad. These feelings about pursuing travel without a necessary endpoint, are summed up in the following excerpt where she describes her plans after university.

P3: I don't know whether I'll do the four years and add years on, or whether I'll do the four years, go away, and work, and then come back a few years on, or just go away, find a job somewhere random, because I like to, like, go places. Like, I've always wanted to travel (...) so I'll maybe go away, work, travel, and come back if I want to. I'm really somebody that just kinda goes with the flow.

Later she described the feelings associated with being away from home; feelings she feels are in stark contrast to one of her flatmates who also comes from her town and is very homesick.

I: So, you like the change?

P3: I like the change (.) definitely like the change.

I: But you get homesick sometimes?

P3: Once in a blue moon. Usually if I'm not feeling well. Like if I don't feel well, I'm like "Oh, I just wish mum was here to make me something", or when at night, and I just can't be bothered to make food.

I: So it's the home comforts you miss?

P3: It's not (.) I don't miss the place, I just miss the people.

She later confirmed this lack of future intentions concerning her hometown, stating, "Going away is going away and if I don't come back it's not a problem". Interestingly, she also later describes her discomfort when a friend from Dumfries that she has met and shared a flat with in Dundee travels back with her for a weekend's visit.

P3: So the three of us all went home this weekend, like me, my two flatmates, we all went home and it was, like, °weird°, even though I know she's from Dumfries, I find it difficult her being in the same place as me (.) I find it strange. It was as if, like, two things mixing together that shouldn't mix (...) it was really an odd feeling.

This account seems to indicate that this situation involved the salience of two different place identities, which is potentially mediated by social identities: the peer groups at home and at university. However, it is the shifts in her account that appear later that feature varying perceptions of place identification and place identity continuity. The first of these shifts comes about later in her interview, when she begins to discuss her home town as her base, "Dumfries is always going to be there for me, it's where my family and friends are and that's fine," but she reasons that it is not appropriate at this time or in the near future, "Like,

I couldn't live there through my 20s, 30s." This statement is quite contrary to her earlier accounts of her future, which were free from association with places and seems to hint at the place becoming appropriate once she is older.

This change in views is confirmed later in the interview when she concedes, "It'd be nice when I'm older...and I want to have kids, and I want to like (.) settle down [...] I just don't have the inkling for it, yet." This account shows a stronger endorsement of place future continuity that is justified by this later life stage and the identities associated with motherhood and 'settling down'. The significance of her hometown is reiterated when she begins to refer to it as her "base" and states: "I think it could be fundamental, it's what makes me so stable, knowing it's always there".

One way of thinking about this tendency to link different types of place relationship with different life stages might be to think about what kinds of place-person relationships are viewed as normative at certain times of life. However, the prevalence of other people and social groups in interviewees' expressions of certain perceptions of place identities hints that this variability may be due to the salience of particular identities varying across the interview. For example, for many people place is bound up with family identity and this identity often involves ideas about rootedness and stability. It might therefore be that people tend to experience a stronger sense of place identity when this identity is salient. In contrast, this might be felt as less appropriate when a student or career-person identity is salient. With this proposal in mind, a re-examination of P5's account of Brighton in the previous 'Importance of Place Identification' theme shows these same identity processes. For example, when she expressed both place referent and place congruent continuity in relation to Brighton because her traveller identity provided her with a fitting residential "badge of membership". In contrast, at other points in the interview, this traveller identity is associated with no sense of place identification and is associated with a view of rootedness as constrictive and limiting.

Summary and Conclusions

This study sought to extend the social psychological literature on place identity and specifically the literature that has explored place identity continuity. It has been suggested that a future-oriented dimension of place identity continuity is missing from this literature despite being noted in passing in some recent research programs (e.g., Speller & Twigger-Ross, 2009). It has also been suggested that a bringing together of social psychological theories of identity and environmental psychological accounts of place identity can forge a new understanding of the nuances of perceived place relationships. This study therefore aimed to satisfy two specific objectives. Firstly, to ascertain if the accounts of the interviewees from varying residential backgrounds and histories contained evidence of themes relating to place referent continuity, place congruent continuity, *and* place future continuity. Secondly, to further analyse the nuances of place identifications and perceptions of place identity continuity to explore the potential identity processes underlying them.

Part I of this study has established the existence of each of the predicted place identity continuity dimensions within interviewee's accounts of their place relationships, and has presented evidence of various subthemes relating to each dimension. These subthemes demonstrate the complexity and rich variation of relationships with places, but also the common feature of temporality within the accounts. In many ways, places act as way-markers in each of these accounts. Often they are considered positively, whether they are associated with positivity in terms of genealogical links and family identity, childhood memories, significant opportunities, or future plans. Equally they can be associated with a lack of belonging, a sense of limitation and constriction, and memories that participants would rather leave behind.

Part II of the analysis began by highlighting the complexity of the potential relationships between each dimension of place identity continuity, showing for example that for some participants past place identifications are a certain part of their future place relationships, whereas for others the past and future were disconnected. The study also established the crucial role of a sense of congruency between place and self, and how this impacted upon past and future dimensions of place identity continuity. Moreover, the role of social groups in the perceptions of congruency and place identification was described and elucidated. Perhaps more importantly this pointed towards the potential role of identity processes, and specifically the role of social context, in perceptions of place identity continuity. Social identity salience was therefore offered as one means by which variation in perceptions might be accounted for.

There are several potential alternative explanations for these findings. Firstly, from a methodological viewpoint, it is possible that the variation that occurs in participants' accounts occurs because the nature of the questions asked and the demands these put on participants to respond in a way they perceive as favourable. Despite the semi-structured design of the interview schedule it is hard to get away from this possibility, but care has been taken to provide a context for each excerpt and where appropriate to include the questions as well as the responses of participants to aid valid interpretations. In addition, the existence of interviews where people adamantly claim no place identifications suggests that the demands of the interview did not preclude this possibility.

According to Taylor (2010), participants could be drawing upon available and normative narratives that relate to place relationships. For example, she discusses the 'born and bred' narrative, the 'logic of return' narrative, and the 'urban identity' narrative that exert societal expectations upon individuals and constrain the nature of potential accounts given due to their role as identity resources. Each of these narratives could be said to correspond

with features of participants' accounts in this study. Taylor also suggests that different narratives can be drawn upon during the course of one interview, giving a sense of variability in accounts that is the product of the discursive work being undertaken at different moments in the interview interaction. Whilst this study does not attempt to provide a counter argument to this position, the distinction between these interpretations is considered the consequence of the epistemological commitments explicated in early passages of this thesis.

Indeed there are several different domains in psychological theorising that could be drawn upon to explain this variation. Cognitive accounts suggest that people tend to make judgements about aspects of themselves depending on whether they concern future, distant or current version of self (Wakslak, Nussbaum, Liberman, & Trope, 2008). It is thought to be useful to have: a) flexibility in self-related thinking that allows more contextualised self-conceptions about the present and near future self, and b) an integrated and schematic sense of self in the distant future. This allows for a unified thread between different versions of self when looking at one's self from a distance, but also flexibility to deal with different situations, e.g. negative feedback, in the present. This means future selves are based on more central elements of self and more superordinate values therefore suggesting perceptions associated with the distant future might be considered more accurate representations of the self (Wakslak et al., 2008). If this theory is applied to the variation in accounts, such as that of P3 above, it might suggest that place identifications that are more representative of self will be expressed when considering the future (a 'return to origin' version of self), whereas a more adaptable and variable version of self is expressed in present terms (traveller, mobility-oriented, or opportunity-seeking self). Again, this interpretation is a product of psychological perspective, and explanations may vary across sub-disciplines. Developmental psychologists might, for example, suggest that problematic events in childhood can lead to dysfunctional

place relationships and psychoanalysts may seek to delve further in to participants' experiences to uncover the latent factors responsible for such varying expressions.

It will, however, be argued in this thesis that it is not necessary to rely on explanations that draw upon personality variables or issues of development and dysfunction; instead it is possible to think of these variations in terms of identity. That is, it is possible that particular identities are either chronically or contextually salient at times that do not include any relevant notion of place or where place is just *less* significant. Indeed, Twigger-Ross and Uzzell (1996) suggest that although some identifications appear not to be place-related, all identities in fact have place implications; they therefore suggest that the identity of 'traveller' or 'nomad' might be more salient for these people. Thus, these individuals may still use places to construct and maintain their identities. This process is reflected in the interview data presented in this study. However, it is also possible that the nomad or traveller identity might be associated with another social identity, such as 'young person'. In cases such as these particular life-stages can be associated with certain identities, and again, this is reflected in the interview data.

The role of identity salience is also in accordance with the identity process model, which suggests that each of its identity principles can be made differentially salient over time in relation to place identities (Speller et al., 2002). Within the present interviews, the importance of people and the social group in these processes was repeatedly made apparent – most prominently in terms of the family group or peers defining the importance of a place, and expressions of place identity continuity. This idea is reflected in the literature showing that human social interaction makes places significant and 'home-like' (Manzo, 2005). It also means that for those that move around a lot the family often constitutes the home. The human geographer Yi-Fu Tuan acknowledges his own difficulty in achieving a continuous place attachment throughout his life's many residential shifts in his autobiography

commenting: "Socially I am likewise adrift for a simple reason - I am single. The one portable soil – family – in which an individual is given natural grounding is not available to me." (Tuan, 1999, p.4). This ability of the family group to provide a 'portable soil' is not however specific only to this social group. Within this group of participants several spent their adulthood in the army and considered it their home, incorporating the people, the belongingness, and the 'return to base' that more physical home-spaces may have otherwise provided.

What is essential to observe from the accounts that have been presented though, is that the drive for continuity acquired via place identifications is by no means a universal phenomenon. Places of origin are not always available, are not always congruent with self and current needs, and some places are completely undesirable because of the memories they house. The challenge that remains is to explore the psychological processes through which these perceptions occur and why they might occur. As has been previously stated, a psychoanalytic, or indeed a fully developmental account of place relationships is not the aim of this thesis. Instead it is the social psychological and identity processes involved in place identity that are the primary concern. With this in mind, it is essential to take forward three specific tasks in the remainder of the series of studies:

- i) To explore the relationships between each dimension of place identity continuity and their relative relationships with place attachment and place identity.
- ii) To explore the primary correlates of each dimension with a specific focus on residential history, age and well-being.
- iii) To explore the impact of social identity salience on perceptions of place identity continuity.

It is towards these challenges that that the rest of this thesis is directed. The first of these challenges is met in Chapter Six, but before this can be done it is necessary to develop a valid measure of place identity continuity. Chapter Six therefore marks a move away from qualitative analysis and towards quantitative exploration of place identity continuity and each of its dimensions.

CHAPTER SIX

Study 2: Development of a Place Identity Continuity Measure

Introduction

The results of Study 1 have suggested that place identity continuity (PIC) is a meaningful psychological phenomenon, at least for the participants involved. Moreover, the study has revealed that these sorts of place-related perceptions are complex and multi-faceted in a manner that extends beyond the limits of the current psychological literature. In recognition of this, the present study sought to build upon the results of Study 1, and existing theoretical knowledge, by applying an empirical social-psychological perspective to its study. The overarching goal of the next two studies is to further explore the dimensions, correlates and consequences of place identity continuity, but in order to gain a full understanding of PIC there must first be some valid and reliable method of measuring the construct.

Although there are existing measures of personal identity continuity (e.g., Lampinen, Odegard, & Leding, 2004) and social identity continuity (Sani et al., 2007), there are no measures of continuity in relation to place identity at present. Study 2 was therefore aimed at developing a quantitative measure of the PIC construct. This process was also expected to facilitate a quantitative confirmation of the structure of the construct in terms of its three main components: place referent continuity, place congruent continuity, and place future continuity, and to look at both personal and social dimensions of each component. In addition, the study sought to provide some initial exploration of the relationships between each PIC dimension and other key place identity measures, as well as aspects of place relationships (e.g., residential history) and key demographic variables such as age. This analysis will also enable determination of the construct validity of the scale.

As mentioned above, this is not the first scale of this type to be created. Sani et al's (2007) Perceived Collective Continuity Scale was also developed to measure perceptions of continuity in relation to an element of identity: social identity. They recognised that whilst the importance of personal self-continuity had been accepted within psychology, there remained little exploration of collective sources of self-continuity. This led to the development of a scale to measure perceptions of identity continuity in national ingroups. Although more exploratory in its nature, reflecting the lack of existing literature at that time, the procedures followed by these authors provide a useful template from which to work when addressing place identity. As well as developing a means to quantify the main dimensions of collective continuity, cultural and historical continuity, in terms of their temporal extension from past to future, they also explored the correlates and consequences of these identity-based perceptions, hammering home their psychological significance. The present study will adopt a similar approach through inclusion of a collection of additional related constructs administered with place identity continuity measures. This process will also help determine the validity of the scale. Each of these has been selected on the basis of issues highlighted within the literature reviewed in earlier chapters and based upon the results of Study 1. Each of these potentially related constructs is discussed below.

Firstly, although the majority of the literature has explored personal relationships with place in line with the interest in place's role in personal identity, there has also been a general acknowledgment of the role of social groups in place identities. Geographers, anthropologists, sociologists, and social psychologists alike have emphasised the social elements of place relationships. Some of them have emphasised the socially symbolic elements of places (Bonaiuto, et al., 1996; Devine-Wright & Lyons, 1997); others the connections between places, group history, and memory (Lewicka, 2008; Milligan, 2003); the roles of places in group life (Hummon, 1992; Low, 1996); or the impact of place changes on

social groups (e.g., Speller et al., 2002; Speller & Twigger-Ross, 2009). Each of these accounts imply the necessity of exploring how perceptions of place continuity relate to the collective, as well as the personal self, and therefore this study also sought to develop a social version of the proposed PIC scale to assess this particular type of place relationship.

This study also included measures of place identity and place attachment. Together these two constructs embody the most common way to assess place relationships: the first being more concerned with the more cognitive processes of identifying with places and with the development of this place-related aspect of self; the second, being more focussed on the emotional affective elements of place relationships. Place identity theorising in the classic works of Proshansky (1978) and later studies (e.g. Cuba & Hummon, 1993; Feldman, 1996), and place attachment theorising in the works of geographers such as Relph (1976) and psychologists such as Giuliani (2003) and Lewicka (2008) have been discussed in full in earlier sections of this thesis. In sum, both bodies of work indicate these constructs are key indicators of place relationships, and as such inclusion of these measures is necessary to measure the significance of place identity continuity in relation to place relationships.

These literatures have each already gone some way to connect place relationships with issues of temporality and continuity. However, at times they have also highlighted how these identity-based perceptions are mediated by the physicality of places, that is, the *actual* continuity of places. This issue, discussed in Chapter Two, is inherent in the human geography literature tying together the physicality and phenomenology of places (e.g., Relph, 1976), but has also been picked up on by psychologists emphasising the importance of physical preservation of places and the impact of place changes (e.g., Stedman, 2003; Speller et al., 2002, Speller & Twigger-Ross, 2009). The connections between these physical and

psychological dimensions of place continuity remain unexplored, however, and thus a measure of perceptions of physical place continuity was also included.

Several other measures have also been deemed important to explore based upon the results of Study 1. Firstly, it was evident during the interviews that perceptually stable and enduring places were often described as providing a sense of security and familiarity, imbuing them with a sense of meaning for participants who claimed an attachment with them. This experience was evident in accounts relating to future-oriented dimensions of PIC, for example, in relation to the 'Place as Survival' theme. It also featured in some of the descriptions of familiarity given in connection to the 'Storehouses of Memory' theme of place referent continuity. However, as these emotions were not directly representative of perceptions of continuity, they were not captured within the PIC measures used in this study. Therefore an additional measure aimed at tapping these feelings was developed to investigate the significance of the cognitions and their connection with PIC.

The last two primary measures selected for inclusion represented an attempt to explore the identity processes that might explain differences in place relationships and perceptions of continuity and discontinuity, in lieu of the later experimental studies. The first corresponds to a body of literature by Chandler and colleagues (Chandler et al., 2003; Chandler & Lalonde, 2008), discussed in Chapter One, relating to the mental health consequences of inability to construct a sense of cultural continuity, namely the incidence of suicide in Aboriginal groups in Canada. This series of studies explored the consequences of different continuity-constructing strategies and drew a clear distinction between individuals and groups that use essentialist strategies, referring to an enduring inner essence and narrative strategies referring to continuity realised via an ongoing life-story. In the present study it was reasoned that those individuals who do not express strong connections with places or

perceptions of place continuity, might simply be those who prefer to construct a narrative sense of continuity (characterised by moving through places), rather than using essentialist strategies that draw upon fixed aspects of identity (for example, places of origin).

For similar reasons, this study also sought to explore whether perceptions of place identity continuity vary according to the nature of mobility-related beliefs, perhaps responding to cultural or familial values, or to the contextual variation discussed earlier. The differences between these measures and PIC dimensions were also of interest. For example, it may be those who hold specific views about the value of residential mobility, or who draw upon narrative methods of continuity construction, endorse stronger views of place congruent continuity and less place referent and place future continuity. Similarly, those who express strong place referent continuity may endorse stronger views about retaining links with significant places and this might correspond to specific patterns of residence. The final measures were therefore related to residency, combined with other important demographics highlighted in the literature, such as age.

In summary, this study aimed to create a place identity continuity scale measuring the proposed three factors representing place referent continuity, place future continuity, and place congruent continuity. This scale development was facilitated by exploration of the collected data using traditional factor analysis to reveal their factor structure, followed by further assessment in a confirmatory factor analytic framework. The validity of the scale was then determined using theoretically related variables. Finally, correlation analyses were employed to explore both the significance of and variance between participants' perceptions of place identity continuity in relation to their most prominent place identities.

Method

Design

The study utilised a cross-sectional, survey design with online administration.

Participants

The sample consisted of 548 undergraduate and postgraduate student participants recruited via student email lists through University Departments across the United Kingdom.

Participants who began the survey but failed to complete it were listwise deleted from the analysis as the non-random nature of their missing data meant it could not be replaced with imputed data (Schafer & Graham, 2002). The total effective sample size after deletion of these cases was 318. The sample included 70 males and 186 females, with 62 participants' sex left unspecified. The mean age of participants was 25.47 years ($SD= 7.95$), with a range of 18 to 61 years. The breakdown of nationalities provided was as follows: British: 181; Scottish: 87; English: 4; Irish: 4; Northern Irish: 4; African: 7; Canadian: 4; American: 2; Indian 2; Pakistani: 1; Singaporean: 1, and the remaining 29 identified themselves as coming from eleven different countries across Europe with each being represented by no more than three participants. Concerning residency, 66 participants stated they were presently residing in the place they answered items with respect to and 190 stated they were not. In terms of total residency, 201 stated they had been resident at some time in their chosen place, 48 had never lived in their chosen place, and 69 did not respond. The mean length of total residency in chosen place was 14.23 years ($SD= 7.42$), with a range of 0 to 40 years.

Measures

Development of the PIC items

An initial collection of sixty questionnaire items was created to measure place identity continuity, with twenty relating to each of the three main categories of PIC. These items were developed both by drawing on the contents of the interview data collected in Study 1, and by drawing upon the structure of items from the perceived collective continuity scale (Sani, et al., 2007), discussed above. More specifically, a series of items was generated for each of the main themes interpreted in relation to each dimension. For example, in the place referent continuity subscale the item ‘This place links me to my memories’ was developed to reflect the ‘Storied Places’ theme; in the place future continuity subscale the item ‘This place will continue to represent me in the future’ was developed to reflect the ‘Projected Congruency’ theme; and in the place congruent continuity subscale the item ‘This is the kind of place I can feel like me’ was developed to reflect the ‘My Type of Place’ theme. This initial collection of items was evaluated by the researcher in conjunction with the supervision team, in terms of each item’s clarity, redundancy and ability to reflect each continuity dimension effectively. Following this procedure a final collection of thirty items were selected for use in the questionnaire, with three items in each subscale being negatively worded to reduce the risk of response biases⁷.

The Questionnaire

Materials consisted of an online survey containing a battery of measures related to the above developed place identity continuity measures in relation to both personal and social dimensions of self. Additional variables were included to investigate the correlates, potential

⁷ The final 30 items are presented in Table 6.1 below with the results of the initial confirmatory factor analysis.

antecedents, and potential consequences of place identity continuity, as well as to assess the validity of the final scale. Questions were answered with reference to a significant place chosen by the participant at the beginning of the questionnaire. Participants generated their own specific place in recognition of the results of Study 1, showing that different places might be more or less significant for people depending on a variety of factors including past experience and levels of place identification. Therefore, whilst variability in scoring is important for the purposes of statistical analysis, it is essential not to impose particular place identities on participants where they may not exist. This approach was adopted by Korpela (1989) who allowed participants to choose their own self-relevant place rather than experimenter-selected place identities in order to access representations of the place-person relationships actually felt to be significant. In order to facilitate this selection, participants were required to generate five places they felt were significant to them. They were then asked to reflect upon this list and select the most significant of these places and answer the subsequent questions in relation to it⁸. The measures that followed are detailed below and the entire questionnaire is provided in Appendix Four.

Place Identity Continuity Measures

Place Identity Continuity (PIC) This included the 30 items initially generated to measure place identity continuity. These were broken down into three main subscales corresponding with the three dimensions of PIC resulting from Study 1. The subscales were labeled as Place Referent Continuity (PRC); Place Future Continuity (PFC); and Place Congruent Continuity (PCC). Each subscale included 10 items, all scored with a 7-point Likert scale format (1:

⁸ Participants originally generated five places and answered with respect to the first place during a pilot study ($N=10$), but it was decided future participants should first generate places then select which of these to use. This was because they reported not being able to decide upon their most significant place until after completing the list. Participants agreed all other questionnaire items made sense and were unproblematic to complete.

totally disagree – 7: totally agree) and higher scores on each subscale represented stronger perceptions of place identity continuity.

Social Place Identity Continuity (SPIC) This section included 30 items generated to measure place identity continuity in connection with social identity. Items corresponded to the previous section in terms of subscales and format. Items were generated by adapting the above PIC items and were preceded by a question asking whether the place selected is linked to a particular group of people. If the answer was yes, participants were asked to answer the following sections in reference to that group. The subscales were labeled as Social Place Referent Continuity (SPRC); Social Place Future Continuity (SPFC); and Social Place Congruent Continuity (SPCC). Each subscale included 10 items, all scored with the same Likert scale format (1: *totally disagree – 7: totally agree*) and higher scores on each subscale represented stronger perceptions of social place identity continuity.

Potential Correlating Measures

Existential Security (ES) This 8-item scale was created based on extracts from Study 1 where people expressed emotions of this sort in relation to their place identities. This included items assessing emotions such as security, reliability, and that the place is ‘meant to be’, which could not be represented completely in the PIC measures. All items were scored with the same Likert scale format (1: *totally disagree – 7: totally agree*) and higher scores on the scale represented stronger perceptions of existential security.

Perceived Physical Continuity (PPC) This 8-item scale was created to assess perceptions of the physical change in chosen places with the aim of finding out how maintenance of the physical features of a place might be related to the psychological relationship between person and place. All items were scored with the same Likert scale format (1: *totally disagree – 7:*

totally agree) and higher scores on the scale represented stronger perceptions of physical place continuity.

Place Attachment (PA) This 12-item scale measures the emotional elements of place relationships in terms of attachment to place (Lewicka, 2008). The original 5-point scale was adapted such that all items were scored with the same 7-point Likert scale format (1: *totally disagree* – 7: *totally agree*) and higher scores on the scale represented stronger perceptions of place attachment.

Place Identity (PI) This is a 10-item measure of strength of place identity, that is, identity resulting from the individual's relationship with place. Four suitable items were drawn from Williams and Vaske (2003) and some were created specifically for this study on the basis of Study 1 interviews. All items were scored with the same Likert scale format (1: *totally disagree* – 7: *totally agree*) and higher scores on the scale represented stronger perceptions of identification with the chosen place.

The following three measures were not based upon specific places, and therefore before beginning this section, participants were informed of this and instructed to answer in accordance with their own general beliefs.

Mobility Beliefs (MB) This 8-item scale was created to assess participants' views on the merits of mobility versus residential stability. This was employed to identify whether those who valued residential mobility may be less likely to perceive place-related identity continuity and as such have less strong place identities. All items were scored with the same Likert scale format (1: *totally disagree* – 7: *totally agree*) and higher scores on the scale represented stronger endorsement of residential mobility as important.

Perceived Personal Discontinuity (PPD) This 3-item scale was created from items drawn from Lampinen et al.'s (2004) diachronic disunity scale, which measures a general sense of discontinuity of identity. This was used to assess whether place-related identity continuity was related to general personal continuity. All items were scored with the same Likert scale format (1: *totally disagree* – 7: *totally agree*) and higher scores on the scale represented stronger perceptions of personal discontinuity.

Identity Continuity Strategy (ICS) This measure was a forced-choice question adapted from Chandler, Lalonde, Sokol, and Hallet's (2003) interview-based strategy for ascertaining whether individuals construct personal continuity according to narrative (story-based) or essentialist (entity-based) strategies. Participants were asked to think about how they might convince somebody that despite all the changes that have taken place their life they remained the same person. Participants were then asked to select between two options: one which described a narrative approach to identity continuity and one which described a more essentialist approach to identity continuity.

Demographic Measures

The final section of the questionnaire included a series of demographic questions. These included specifications of sex, age, and nationality. There were also a series of questions relating to the residential circumstances of participants. These asked whether or not the participant was resident in the place they had chosen and if so for how long, and whether or not the participant had ever been resident in the place they had chosen, and again, if so, for how long.

Procedure

Items were administered using the SurveyMonkey software for online data collection. This allowed the delivery of all questionnaire and demographic items to a large sample of

participants. Participants were required to read a study information sheet and to provide informed consent in line with ethical requirements, before clicking on to the survey proper. Participants took part anonymously, although they had the option of leaving an email address to be entered in to a prize draw for an online store voucher worth £30. They were assured that their data would be stored securely and confidentially, and were informed their participation was voluntary, with no direct monetary reward for taking part. Once the online survey had been active long enough to gain a sufficient sample for confirmatory factor analysis, the survey link was closed and the data were downloaded for analysis.

Results

Data Screening & Descriptive Statistics

First all negatively coded items were reversed so that all items on each scale represented stronger endorsement of that variable. Composite variables were then created and the usual checks for normality of distribution were conducted. Inspection of the histograms for each variable suggested that some were slightly negatively skewed with most values clustering nearer the positive end of the scales. This was the case for the following variables: PRC, PFC, PCC, SPRC, ES, and PI. However, the mobility beliefs (MB) variable was positively skewed with most values clustering just below the mid-point. Values for skew and kurtosis for each of these variables exceeded the critical value of 3.75, however transformation of the data was not performed due to the large sample size ($N > 200$), which makes subsequent statistical analysis less sensitive to non-normality (Field, 2009; Tabachnick & Fidell, 2007) and due to the robustness of the estimation methods used to compare the implied and sample covariance matrices in this study. The nature of the scores is reflected in

the means and standard deviations of each scale provided below in Table 6.5⁹. It is likely that positive scores reflect the method of asking participants to choose significant places contributing to the generally positive endorsement of items, and therefore any issues of skew make theoretical sense.

There was no evidence of multicollinearity as all correlations between variables were below .90, VIF values on all variables were all below 10, and Tolerance values were all above .10. Examination of randomly tested standardised residual scatterplots showed relationships between variables to be generally linear and no with evidence of homoscedasticity. Examination of the boxplots for each variables suggested extreme outlying values for three participants only on the place referent continuity variable. As the scores represented possible values and there was no evidence of error in data entry or systematic outlying values for these participants, their data were retained in the analysis. This decision was supported by the similarity in number between the 5% trimmed mean for the variable and the final mean including outlying values, which were 6.17 and 6.01, respectively (Pallant, 2001).

Development of the Place Identity Continuity Scale

For the purposes of confirmatory factor analysis, missing data relating to the place identity continuity items (14.22%) were imputed in the LISREL program using maximum likelihood estimations (LISREL 8.8; Jöreskog & Sörbom, 2004). This allowed for the use of modification indices – not available in datafiles containing missing data – to help identify useful items, and also enabled use of goodness-of-fit indices sensitive to missing data (Schafer & Graham, 2002). In the first stage of scale development it was necessary to submit

⁹ Note that Table 6.5 contains the descriptive statistics for the final PIC scales following confirmatory factor analyses.

all theoretically generated items to factor analysis to explore whether the items loaded appropriately on to the proposed three-factor solution before entering in to a further confirmatory factor analysis phase. The data were then tested for suitability for use in factor analysis. Based upon the correlation matrix between all 30 PIC items, the Kaiser-Meyer-Olkin measure of sampling adequacy was .90 and Bartlett's Test of Sphericity was significant ($p < .001$). These results suggested that the data were suitable for factor analysis (Pallant, 2001).

As the PIC items were based upon prior theory, namely both the extant literature and the results of Study 1, which specifies three main dimensions of perceived identity continuity, a confirmatory factor analysis approach was adopted to confirm that hypothesised three factor solution. Principal Axis Factoring (PAF) was chosen as a suitable technique as opposed to more exploratory techniques such as principle components analysis (PCA). This was because PAF is more appropriate when pre-existing, theoretically-driven ideas about the number of factors and associated items exist, and because it allows for better modelling of error variance (Tabachnick & Fidell, 2007). In comparison to PCA, PAF identifies the impact of unobserved latent factors (subscales) on the observed indicator variables (questionnaire items) using the patterns of common variance shared by these variables (Brown, 2006). It also allows for non-orthogonal factor solutions appropriate in the hypothesised model.

Following direct oblimin rotation¹⁰ of the three-factor solution to improve interpretability of the factors, Factor 1 accounted for 27.29% of the variance, Factor 2 accounted for 19.97 % of the variance, and Factor 3 accounts for 8.91% of the variance

¹⁰ An oblique rotation was chosen as this technique allows for non-independence between factors (Tabachnick & Fidell, 2007). This was deemed necessary because previous theoretical models suggest that continuity between the past and future, as well as a sense of personal congruity realised through place relationships, will be correlated and this is supported by the results of Study 1.

meaning the three-factor PIC model accounted for 55.48% of the total variance in participants' responses. Following Johnson and Lecci (2003), various criteria were applied to evaluate the extracted factors.

Table 6.1 Direct Oblimin Rotated Loadings of the Thirty Place Identity Continuity (PIC) Items Following CFA

Items	Factor 1	Factor 2	Factor 3	M	SD
1. I can reconnect to my past in this place	.02	.83	-.07	6.11	1.52
2. This place links me to my memories	.11	.81	-.12	6.33	1.18
3. This place is not linked to any significant events in my life <i>R</i>	-.03	.29	.03	6.05	1.58
4. My past is rooted in this place.	-.10	.75	.10	5.41	1.87
5. This place is not connected to my history <i>R</i>	-.03	.69	-.01	5.86	1.69
6. If this place is lost, I will lose a link with my past.	-.06	.43	.33	5.05	1.86
7. This place represents periods from my life.	.13	.61	.02	6.33	1.03
8. This place connects me to my past.	-.06	.90	.06	5.78	1.55
9. I sense no link to my past in this place. <i>R</i>	.01	.87	-.08	6.26	1.32
10. This place links me to previous times in my life.	.08	.84	-.04	6.02	1.38
11. I will have new experiences in this place in the future.	.17	-.15	.44	5.15	1.81
12. This place will not continue to be a part of my life <i>R</i>	.00	-.03	.49	5.33	1.89
13. Part of me will survive in this place	-.02	.00	.70	5.32	1.56
14. This place will continue to represent me in the future.	.05	-.09	.75	4.54	1.76
15. My memories will be preserved for the future in this place.	.05	.04	.63	5.05	1.61
16. This place links me to my future.	.23	-.24	.44	4.12	1.83
17. I will always be connected to this place.	.03	.20	.52	5.97	1.25
18. This place will not be significant for me in the future. <i>R</i>	.11	-.01	.38	5.60	1.39
19. Part of me will be preserved in this place.	-.05	-.01	.80	5.00	1.59
20. I will not always be connected to this place. <i>R</i>	-.05	.15	.56	5.34	1.62
21. This place has features that allow me to express the kind of person I am.	.61	-.03	.11	5.19	1.69
22. This place does not offer what I want in my life. <i>R</i>	.76	-.06	-.04	4.56	1.82
23. This place has features I value.	.55	.11	.23	5.77	1.30
24. This place has the qualities I look for.	.82	.06	.04	5.21	1.53
25. This is the kind of place I can feel like me.	.80	.08	-.02	5.50	1.52
26. This place doesn't have the type of qualities that suit me <i>R</i>	.78	.06	-.03	5.15	1.57
27. This place can provide me with the things I feel I need.	.74	-.09	.06	4.92	1.64
28. This place has the characteristics that are important to my life.	.78	.02	.08	5.13	1.53
29. I can be who I want to be in this place.	.81	.03	-.07	5.35	1.66
30. This place does not match the way I see myself. <i>R</i>	.80	-.02	-.05	5.00	1.63

Note: Factor loadings of items selected for further analysis on each factor are in bold. Reverse coded items are marked with *R*.

Firstly, it was ensured that each extracted factor had at least three items with loadings over .35 to avoid an underidentified model when cross-validating results, and because loadings below this level are more likely to reflect error variance. Secondly, factors needed to display minimal cross-loading of items. Both of these features suggest that these items do not discriminate effectively between the dimensions, and as such are unlikely to replicate.

At this stage, four indicator variables, items PRC3, PRC6, PFC6, and PFC8, were excluded from the model either due to low-loading or cross-loading with one of the other factors. Following these exclusions, all retained items loaded on the expected factor and each factor was clearly interpretable as respectively relating to the place referent continuity, place future continuity and place congruent continuity dimensions of PIC (See Table 6.1 above for items, factor loadings and evidence of the retained items). This left a three factor model including 26 items for subsequent confirmatory factor analysis.

The same procedure was followed for the SPIC items. Again, the data were tested for suitability for factor analysis and were satisfactory (KMO = .93, and Bartlett's Test of Sphericity was significant at $p < .001$). Factor 1 accounted for 38.89% of the variance, Factor 2 accounted for 14.96%, and Factor 3 for 7.11% of the variance; this meant that together these factors accounted for 60.95% of the variance in participants' responses. According to the criteria set out above the following low-loading and/or cross-loading items were removed following PAF: SPRC6, SPRC10, SPFC1, SPFC 7, and SPFC10. This left a three factor model with all items loading on the expected factor. This model included 25 items to be entered into stage two of item selection using confirmatory factor analysis. All items, factor loadings and evidence of retained items can be found below in Table 6.2.

Table 6.2 Direct Oblimin Rotated Loadings of the Thirty Social Place Identity Continuity (SPIC) Items Following CFA

Items	Factor 1	Factor 2	Factor 3	M	SD
1. This place is connected to the past of my group	.10	.71	.14	5.99	1.38
2. This place links my group to its history	-.03	.77	-.02	5.57	1.60
3. This place is not linked to any significant group events <i>R</i> from the past.	-.00	.74	-.03	5.92	1.35
4. The history of my group is rooted in this place.	-.13	.70	-.21	5.36	1.76
5. My group has no history in this place <i>R</i>	-.06	.74	-.11	6.12	1.22
6. If this place is lost my group will lose a link to its past.	.05	.27	.41	4.91	1.82
7. This place represents periods in my group's history.	.07	.76	.00	6.01	1.28
8. This place is unrelated to the past of my group. <i>R</i>	-.05	.82	.02	6.13	1.25
9. This place is connected to the past of my group.	.14	.77	.02	5.86	1.34
10. This place is linked to previous generations of my group.	-.12	.20	-.44	3.80	2.25
11. New group histories will be made in this place.	.14	-.20	-.56	5.16	1.73
12. This place will not continue to be significant to people <i>R</i> in my group.	.17	-.02	-.43	5.09	1.78
13. My group's culture and tradition will live on here.	-.07	-.12	-.84	4.44	1.77
14. This place will continue to represent my group in the future	.13	-.07	-.81	4.61	1.79
15. This place will help preserve the memories of my group for the future.	.08	-.02	-.71	5.06	1.56
16. Future generations of my group will be linked to this place.	-.01	-.04	-.81	4.37	1.77
17. My group will always be connected to this place.	.05	.28	-.53	5.31	1.57
18. This place will not be significant for my group in the future <i>R</i>	.16	-.11	-.63	4.99	1.70
19. My group will be preserved in this place.	-.02	-.02	-.84	4.25	1.78
20. My group will not always be connected to this place <i>R</i>	.13	.17	-.53	4.54	1.78
21. This place has features that allow my group to express the kind of people they are.	.69	.02	-.06	5.39	1.38
22. This place does not offer my group what it wants <i>R</i>	.68	-.06	-.12	5.07	1.58
23. This place has the types of features that my group values.	.81	.01	-.07	5.39	1.27
24. This place has qualities that people in my group look for.	.81	.03	-.07	5.31	1.29
25. This is the kind of place people in my group can feel like themselves.	.85	.05	.12	5.57	1.20
26. This place does not have the type of qualities that suit my group. <i>R</i>	.73	-.02	-.01	5.04	1.51
27. This place can provide people in my group with what they need.	.75	-.09	-.14	5.15	1.40
28. This place has characteristics that are important to people from my group.	.67	.09	-.17	5.44	1.27
29. People from my group are able to be themselves in this place.	.76	.03	.03	5.69	1.08
30. This place does not match the way my group defines itself. <i>R</i>	.70	.08	.02	5.19	1.50

Note: Factor loadings of items selected for further analysis on each factor are in bold. Reverse coded items are marked with *R*.

Confirmatory Factor Analysis in AMOS

In order to make a judgement about the dimensionality of the PIC measure and to refine the scale, a further confirmatory factor analysis approach was adopted using the AMOS 17.0 program (Arbuckle, 2008) for structural equation modelling (SEM). Firstly, a measurement model was specified representing the three factors as latent variables and the 26 remaining PIC items as observed – or indicator – variables. Model fit was assessed using a range of goodness-of-fit indices to make allowances for both the strengths and weaknesses inherent in each index (Brown, 2006). These included the chi-squared statistic, the Normed Fit Index (NFI; Bentler & Bonett, 1980), the Comparative Fit Index (CFI; Bentler, 1980) and the Root Mean Square Error of Approximation (RMSEA; Brown & Cudek, 1993). Values of .90 or above on the CFI, and NFI; .10 or less on the RMSEA; and a non-significant chi-squared test statistic traditionally denote a satisfactory fit of the model to the observed data (Brown & Cudeck 1993).

There has been some debate in the literature regarding the most appropriate acceptable levels associated with fit indices (e.g., Barrett, 2007). Some fit indices have therefore been made stricter. For example, RMSEA is now generally recommended to be below .07 (Steiger, 2007). However, acceptable levels are often dependant on issues such as the amount of parameters estimated in the model (Arbuckle, 2008), and a general recommendation is therefore to include a variety of fit indices from which to judge the effectiveness of model fit (Bentler, 2007). This approach was therefore adopted in the present study.

Confirmatory factor analysis using maximum likelihood estimation methods indicated that the initial PIC measurement model displayed a largely unsatisfactory fit with the observed data (see Table 6.3 below for results on all goodness-of-fit indices). To improve

the accuracy of the model fit and identify the best items for measuring each PIC factor, specific parts of the CFA output were used to identify weak indicator items according to the following procedure. Firstly, it is possible to identify items with the lowest standardised regression coefficients in relation to each latent variable. These low-loading items are removed sequentially and a reassessment of model fit is conducted following each modification by observing the reduction in the chi-square statistic achieved after each re-analysis. A chi-squared difference test for model comparison can then be conducted to test the improvement in the model (Bentler & Bonett, 1980). This process continues until no further significant improvement of the chi-squared goodness-of-fit statistic is obtained.

Secondly, modification indices, which report potential reductions in the chi-squared statistic when specific potential paths are added to the model, can be examined to identify changes that will improve model fit (Blunch, 2008; Garson, 2012). In an analysis of this sort, this means looking at patterns of covariance between error terms associated with indicator variables and correlating them where suggested, with the caveat that these relationships should make theoretical sense. Specifically, it is not advised to correlate error terms across factors, as these should not share variance (Garson, 2012). Lastly, standardised residual covariances can be examined to identify specific variables that are contributing most to discrepancies between the measurement and observed models. When comparing the models the aim is to reduce residual errors, therefore any relationships between variables showing large residual values show where the hypothesised model is unable to recreate the covariance matrix of the sample model. If a variable consistently displays large residual covariances then it can be considered for removal (Blunch, 2008). Again, both of the above procedures are following by iterative reassessment of model fit and inspection of the difference in the chi-squared statistic.

For this model, this procedure led to the removal of the following items: PRC7; PFC1, PFC2, PFC7, PCC1, and PCC3, and the addition of three correlational paths between error terms on the PCC factor and one on the PRC factor (see Figure 6.1, below). At the end of this process item PFC10 was observed as still being low-loading, and therefore could have been removed. It was however decided to retain it as its removal did not cause a large difference in the chi-squared value and the model fit was already deemed satisfactory. Moreover, removal of the item may have created a problematic model due to too few indicator variables associated with the PFC latent variable. Models that include too few indicator variables can lead to problems in estimating error correctly and providing suitable solutions (Bollen, 1989; Brown, 2006).

The new 20-item model resulted in a better and adequate fit (see Table 6.3 below for values on all fit indices for each model). Although, the RMSEA, NFI and CFI were now within satisfactory ranges, and the χ^2 / df was below the recommended level of 5, there still remained a significant chi-squared result. This result is however likely in sample sizes above 200 participants, as the chi-squared statistic is sensitive to sample size and likely to produce non-significant results in these circumstances (Brown, 2006; MacCallum & Austin, 2000). However, a chi-squared difference test showed that the chi-squared statistic for the final 20-item model was significantly lower than in the original 26-item model (χ^2 difference (133) = 702, $p < .0001$). The revised 20-item model with standardised beta regression coefficients is displayed in Figure 6.1, in which rectangles represent observed variables, ovals represent latent variables, single headed arrows represent the impact of the latent variable upon each indicator variable, and double-headed arrows represent the relationship between latent variables.

Finally, it is desirable to avoid confirmation bias when assessing the fit of any model within a dataset by looking at alternative structural solutions (Jöreskog & Sörbom, 2004).

For this reason a second measurement model was constructed where only one overall continuity factor impacted on all observed variables. This is a theoretically appropriate model to test in light of earlier social psychological conceptions of identity continuity (Breakwell, 1987), which have been described as representing a “conceptual thread connecting past, present, and future time-slices of identity” (Vignoles, 2011, p. 414), and operationalisations of the construct as such for the study of place identity (Droseltis & Vignoles, 2010).

The fit of this alternative one-factor version of the scale with the observed data was assessed and all goodness-of-fit indices indicated that this model provided a poor fit with the data. To compare this model with the three-factor model, the Akaike Information Criterion (AIC; Akaike, 1987) was used to demonstrate the relative goodness-of-fit of each model, with a small AIC level indicating better model fit (Three-factor model: AIC = 669.53; One-factor model: AIC = 2399.74). Crucially, this non-standardised index takes into account the complexity of each model as well as model fit, and so indicates the superiority of the three-factor model despite the parsimony of the one-factor model. The results for the original, modified and alternative one-factor models are provided below in Table 6.3 and graphic representations of the models are provided in Figures 6.1 and 6.2.

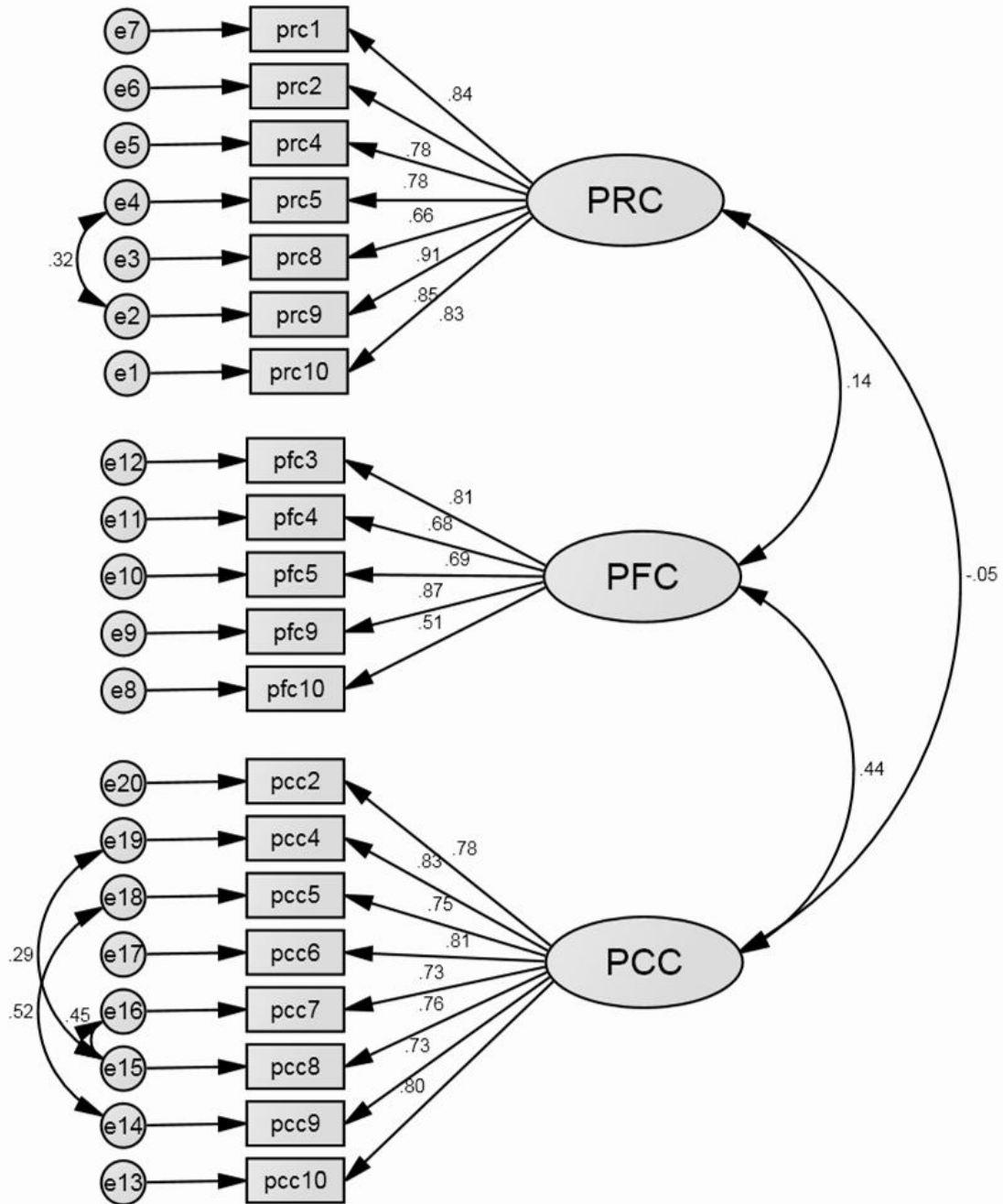

Figure 6.1 Results of CFA for the Refined 20-item Three-factor PIC Model

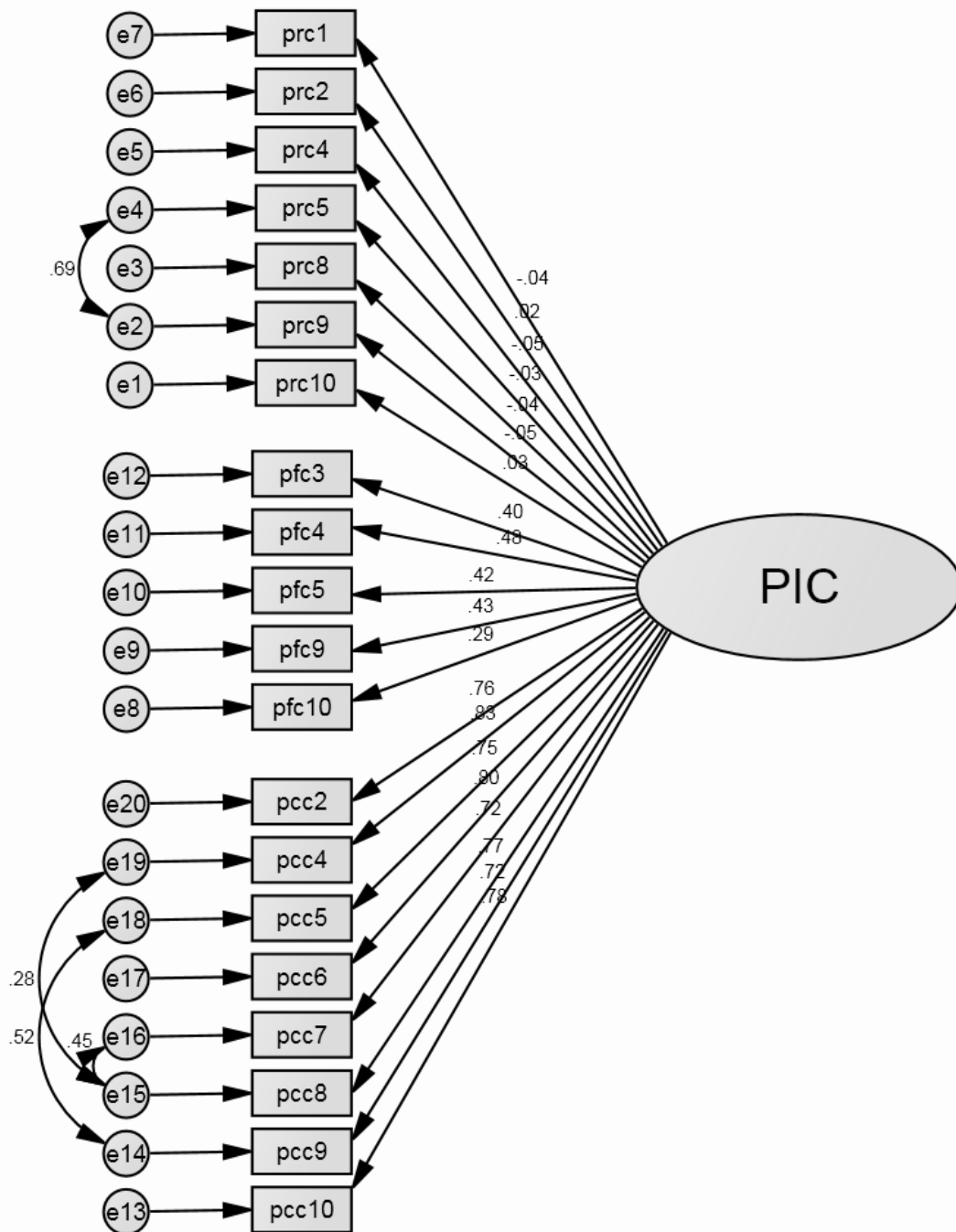

Figure 6.2 Results of CFA for the Alternative 20-item One-factor PIC Model

Table 6.3 Goodness-of-fit Indices for the Original Three-factor Model, Refined Three-factor Model, and the Refined One-factor Model of Place Identity Continuity Items

	<i>N</i>	χ^2	df	χ^2 /df	NFI	CFI	RMSEA
Initial three-factor model	26	1058.81*	296	3.58	.81	.86	.09
Refined three-factor model	20	356.59*	163	2.19	.92	.96	.06
Alternative one-factor model	20	2271.74*	166	13.69	.49	.51	.20

Note: * $p < 0.01$, *N* = Items; NFI = Normative Fit Index; CFI = Comparative Fit Index; RMSEA = Root Mean Square of Error Approximation.

Following successful selection of items to measure all three dimensions of place identity continuity, the same procedure was followed for the social place identity continuity (SPIC) items answered with respect to the social groups connected to participants' chosen places. Again, a measurement model including 25 observed indicator variables (questionnaire items) and three latent factors was specified based on the results of the principal axis factoring presented above in Table 6.2. This initial model provided a poor fit with the observed data therefore the same procedures detailed above were followed to facilitate model trimming. This resulted in a 20-item measurement model that showed an acceptable fit with the data and improvements on all the goodness-of-fit indices (shown below in Table 6.4). Moreover, a chi-squared difference test indicated that the reduction in the chi-squared statistic between the models was significant (χ^2 difference (133) = 702, $p < .0001$). As before, an alternative one-factor model was also tested and provided an unsatisfactory fit with the observed data, and a smaller AIC value again indicated the strength of the three factor model over this alternative model (Three-factor model: AIC = 627.11; One-factor model: AIC = 2376.73). The results for the original, modified and alternative one-factor models are provided below in Table 6.4 and graphic representations of the models are provided in Figures 6.3 and 6.4.

Table 6.4 Goodness-of-fit Indices for the Original Three-factor Model, Refined Three-factor Model, and the Refined One-factor Model of Social Place Identity Continuity Items

	<i>N</i>	χ^2	df	χ^2 /df	NFI	CFI	RMSEA
Initial three-factor model	25	1011.64*	272	3.72	.84	.87	.09
Refined three-factor model	20	497.11*	165	3.01	.90	.93	.08
Alternative one-factor model	20	1740.82*	168	10.36	.64	.66	.17

Note: * $p < 0.01$, *N* = Items; NFI = Normative Fit Index; CFI = Comparative Fit Index; RMSEA = Root Mean Square of Error Approximation.

As can be seen in the below models, following item selection there remained eight items measuring PRC, five measuring PFC, and eight measuring PCC. Similarly there remained eight items measuring SPRC, six measuring SPFC, and eight measuring SPCC. Mean scores, standard deviations, and Cronbach's alpha coefficients for scale reliability were calculated for each new and established scale, with each scale demonstrating good inter-item reliability (above .70; Pallant, 2001). Pearson's correlation coefficients were then calculated to explore the relationships between PIC dimensions and the additional measures included in the questionnaire¹¹. All results are presented in Table 6.5, below.

¹¹ There were no significant differences on any of the variables according to sex or whether participants were parents or not, therefore results for these groupings have been combined.

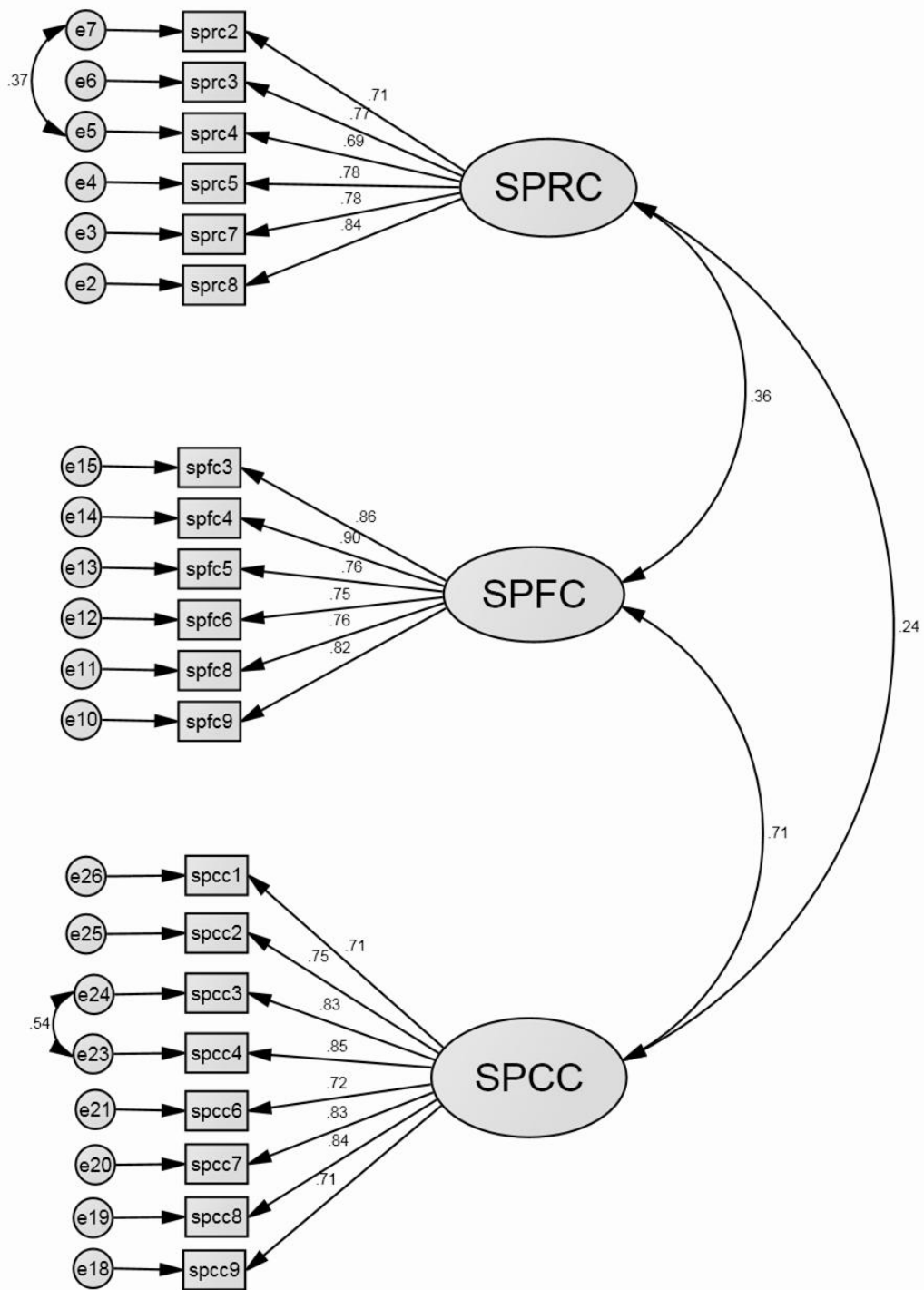

Figure 6.3 Results of CFA for the Refined 20-item Three-factor SPIC Model

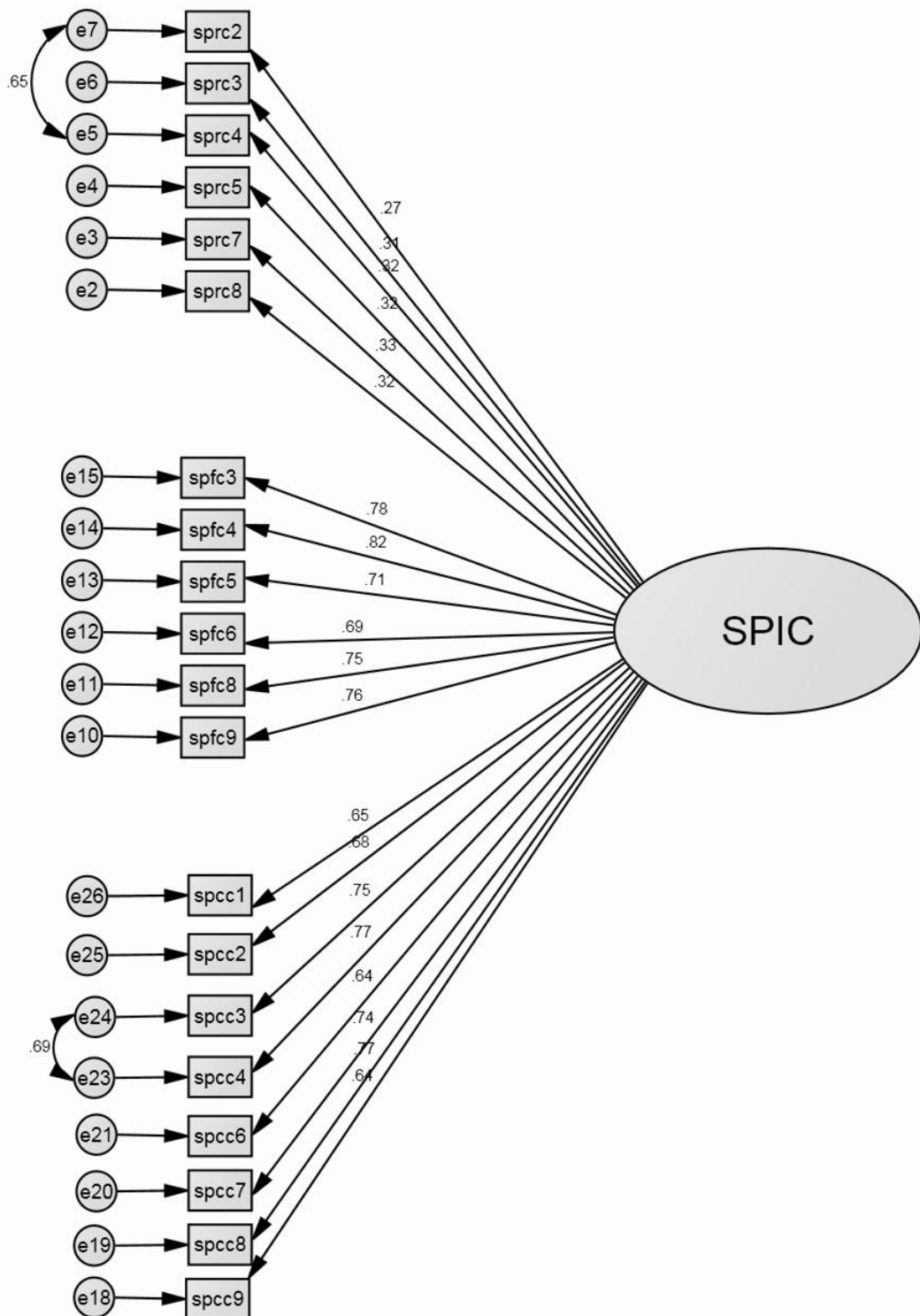

Figure 6.4 Results of CFA for the Alternative 20-item One-factor SPIC Model

Table 6.5 *Correlations and Descriptive Statistics for Study 2 Variables*

Variables	1	2	3	4	5	6	7	8	9	10	11	12
1. PRC	--											
2. PFC	.14*	--										
3. PCC	-.05	.42**	--									
4. SPRC	.58**	.19**	-.02	--								
5. SPFC	.20**	.62**	.40**	.35**	--							
6. SPCC	.10	.48**	.64**	.21**	.66**	--						
7. PA	.15*	.50**	.66**	.14*	.43**	.57**	--					
8. PI	.34**	.45**	.55**	.32**	.41**	.57**	.69**	--				
9. MB	-.22**	-.23**	-.25**	-.19**	-.23**	-.24**	-.44**	-.37**	--			
10. ES	.17**	.48**	.51**	.20**	.42**	.48**	.71**	.59**	-.42**	--		
11. PPD	-.15*	-.07	-.13*	-.15*	-.27**	-.23**	-.19**	-.18**	.21**	-.25**	--	
12. PCP	.09	.45**	.29**	.09	.46**	.32**	.30**	.33**	-.06	.37**	-.09	--
Mean	5.97	5.05	5.10	5.85	4.62	5.31	5.16	5.71	3.16	5.35	4.11	4.98
SD	1.26	1.26	1.31	1.15	1.45	1.10	.96	1.02	.81	1.06	1.49	1.08
α	.93	.83	.93	.90	.92	.93	.84	.91	.70	.85	.73	.83

Note: * $p < .05$; ** $p < .01$. PRC: Place Referent Continuity; PFC: Place Future Continuity; PCC: Place Congruent Continuity; SPRC: Social Place Referent Continuity SPFC: Social Place Future Continuity; SPCC: Social Place Congruent Continuity; PA: Place Attachment; PI: Place identity; MB: Mobility Beliefs; PPD: Perceived Personal Discontinuity; and PCP: Perceived Continuity of Place.

Correlations between Place Identity Continuity Subscales

The first key results to observe are the relationships between the subscales relating to each PIC dimension. Firstly, place referent continuity is not related to place congruent continuity ($r = -.05, p = \text{NS}$) and only has a small but significant relationship with place future continuity ($r = .14, p < .05$). Place future continuity is however connected with place congruent continuity ($r = .42, p < .01$). This pattern is slightly different for the social place identity continuity items. Here the social place referent continuity is connected with the social place congruent continuity ($r = .21, p < .01$) and social future place continuity ($r = .35, p < .01$). SPFC is also strongly related to perceptions of SPCC ($r = .66, p < .01$). In this sample the group most commonly chosen was the family, following by friends.

PIC and Place-related Measures

All dimensions of place identity continuity were positively related to place attachment (PA) ($r = .14; p < .05 - r = .66; p < .01$) and existential security (ES) ($r = .17 - .48; p < .01$), and they were also all negatively related to expressed beliefs regarding the benefits of residential mobility (MB) ($r = -.19 - -.25; p < .01$). The relationships between perceived personal discontinuity (PPD) were not particularly strong, although most were significant at the 5% level and in the predicted negative direction apart from place future continuity ($r = -.07; p = \text{NS}$). The perceived (physical) continuity of place (PCP) was moderately and positively related to both social and personal dimensions of future and congruent continuity ($r = .29 - .46; p < .01$), but no significant relationships were found between place referent continuity and the physical continuity of places for either personal or social variables.

Assessing Validity

There are a number of features of these correlational patterns between the PIC scale and other place-related measures that help to establish the construct validity of the scale. In order to assess the concurrent validity of the scale the relationship between PIC and place attachment (PA) was examined. Theorising on the place attachment construct has suggested that a sense of continuity across time with significant places may be an essential antecedent of attachment because these emotional connections develop through repeated embedded interactions (Knez, 2005). As such it is expected that PIC and PA should be positively correlated if the PIC scale is capable of successful measurement of perceived continuity in place identities. Observation of the correlation matrix show this to be the case for all PIC and SPIC variables ($r = .15, p < .05$ – $r = .66, p < .01$), with the strongest correlations being between place attachment and dimensions of place future and place congruent continuity, showing the importance of an anticipated future connection and a sense of fit for attachment strength.

Similarly, both place attachment theorists (e.g., Lewicka, 2011a, 2011b; Nielsen-Pincus, Hall, Force, & Wulfhorst, 2011), and sociologists (e.g., Low, 1992) have emphasised the importance of length of residence in a place for determining place relationships. It should be expected then that past-oriented place identity continuity should also be linked to length of residency due to the accumulation of residential experiences and memories. The results show this to be the case for both individual and social place referent continuity in relation to total years of residency in the chosen place ($r = .50, p < .01$ and $r = .35, p < .01$, respectively). This finding also supports the concurrent validity of the PIC and SPIC scales.

The above confirmation of concurrent validity helps provide validation for the dimensional approach to PIC measurement resulting from the earlier CFA by showing that

each PIC dimension is differentially associated with key place-related measures. The utility of the scale is also demonstrated by its predictive validity. Predictive validity was assessed by examining the relationship between scores on the PIC scales and the strength of place identification. On the basis of the existing theoretical literature it was reasoned that place identity continuity is a highly desirable feature of place relationships that acts to reinforce, validate, and strengthen place identity. Places characterised in this way are recognized as providing an increased sense of belongingness likely to encourage individuals, and groups, to identify more strongly with them. Following these observations it was predicted that places relationships characterised by a sense of perceived continuity will increase place identification, therefore a valid PIC measure should also be positively correlated with measures of place identification. Results showed that all dimensions of place identity continuity, for both personal and social relationships with chosen places, were positively related to place identity strength ($r = .32 - .57; p < .01$), providing support for the predictive validity of the scale.

Concerning the remaining variables, there are a number of relationships to note. Firstly, there were positive correlations between age and place referent dimensions of continuity (PRC: $r = .28, p < .01$; SPRC: $r = .13, p < .05$), but these were weak. Concerning the effects of narrative and essentialist identity continuity strategies on PIC, independent samples t-tests were used to look at the differences between those with essentialist and narrative identity continuity strategies on all place-related variables. Results showed that although means of the PIC subscales were generally slightly higher in the essentialist condition, there were no significant differences between groups on any of the variables, or on levels of place attachment and place identity in general ($p = .12 - p = .95$). This set of analyses did however show that those who claimed to construct their sense of personal continuity using more narrative strategies were also more likely to endorse stronger views about the

value of mobility ($t(251) = -2.41; p < .05$) and more likely to experience a sense of personal discontinuity ($t(251) = -2.09; p < .05$) suggesting that this simple measure is able to distinguish between groups successfully, and is therefore worthy of further study in an alternative sample.

Discussion

The principle objective of Study 1 was the construction and validation of a Place Identity Continuity (PIC) Scale. A multi-item measure was therefore developed using a combination of traditional exploratory factor analysis and confirmatory factor analysis. This process involved confirming the factors underlying responses to the proposed PIC items and the construction and testing of a measurement model representing the scale and underlying latent variables. From this, optimal sets of items for the final scale, and for a group-based version of the scale, were selected. Both versions of the scale – individual and social – corresponded to the three dimensions of place identity continuity resulting from Study 1, and further confirmation of this three factor structure was provided by favourable comparisons with alternative one factor models. In addition, the variable relationships between each dimension and the other dimensions, and each dimension and other place-related variables, also confirmed the three factor nature of PIC. The intercorrelations between PIC and SPIC measures not only helped to demonstrate the utility of the three factor structure but also helped evidence the construct validity of the new measures. Furthermore, these analyses revealed perceptions of place identity continuity were found to be associated with a range of expected place-related variables such as place attachment and residential history.

Importantly, perceptions of place identity continuity were found to be significantly associated with place identity strength, showing that perceived continuity is an important feature of place identities, and bringing the place identity literature in line with the social

identity literature showing perceptions of collective continuity to be associated with a stronger sense of identification with national, regional, and family groups (Bowe, 2008; Herrera et al., 2011; Sani et al., 2007). However, the study also challenged traditional assumptions present in the literature discussed in Chapter Two and Three, by demonstrating that place congruent and place future continuity are just as, if not more, important than having a rooted sense of historical connection with place.

Concerning the brief measure of existential security developed for this study, intercorrelations did indeed reveal the significance of these feelings supplementing the interview evidence provided in Study 1. This proposed connection between security, stability and continuity is not dissimilar from Giddens' (1991) notion of 'ontological security', and might be due to the capacity of places to embody personal and social history, and help furnish individuals with a sense of projected future. This suggestion is certainly in line with some of the earlier commentaries by geographers and sociologists discussed in Chapter Two. For example, in Lowenthal's (1975) descriptions of the security and psychological comfort derived through historical preservation and genealogical connection, which can also help provide individuals with a sense of anticipated future. Indeed, some connections between feelings of ontological security, constancy, and continuity have already been touched upon by researchers investigating the importance of home spaces (Dupuis & Thorns, 1998; Hiscock, Kearns, Macintyre, & Ellaway, 2001). However, as well as being linked to perceptions of both social and personal place identity continuity this measure was strongly related to both place identity and place attachment strength, further signalling its importance as a feature of some place-person bonds and as a potential area of future study.

It remains the task of the next studies, to reconfirm the structure of the PIC and SPIC scales and to further explore the consequences of place identity continuity; particularly as PIC it has been found to be related to place identification. One way this might be achieved is

to investigate whether PIC has any impact on psychological well-being because this connection has already been found between personal and social types of identity continuity (e.g., Chandler et al., 2003; Sani, Bowe & Herrera, 2008). In addition, because the nature of identity continuity strategy has been unable to account for differences in expressions of place identity continuity, the task of explaining the nuances of these place identity relationships remains. This suggests examining the role of context in explaining the variations in PIC found in Study 1 should also be a primary aim of the subsequent studies.

CHAPTER SEVEN

Study 3: Place Identity Continuity and Psychological Well-Being

Introduction

Study 2 culminated with the development of a scale to measure perceptions of place identity continuity (PIC) in relation to both personal and social aspects of self. The present study seeks to provide further support for the validity of the newly developed scale through its cross-validation. It is often considered desirable in factor analytic studies to use an independent sample to cross-validate the original factor structure using confirmatory factor analysis (Cudeck & Brown, 1983). Replication of the model fit from Study 2 would be particularly advantageous due to the danger of capitalising on chance relationships in a particular data set when the same data set is used for model re-specification (Fife-Schaw, 2000), as occurred in Study 2. In addition, there is an often highlighted weakness in social psychological investigation pertaining to the fact many studies are based solely on the responses of an undergraduate student population (Pancer, 1997). It would therefore be desirable to use confirmatory factor analysis to demonstrate good model fit in an alternative population. For these reasons, the primary aim of Study 3 was the cross-validation of the PIC scale using a general public population, with the aim of replicating the three factor structure found in Study 2.

The development of the PIC measure in Study 2 also provided a means to explore the potential antecedents and consequences of these temporal dimensions of place identity by establishing which place-related variables correlated with PIC. Through this method it was found that perceptions of place-related continuity were associated with place identity and place attachment strength, feelings of existential security, perceptions of personal continuity, perceptions of physical place continuity, and beliefs about the value of residential mobility.

In addition, key differences were found in ratings of PIC according to demographic variables such as residential status and history in chosen places, and according to the way participants construct their own sense of identity continuity – in accordance with either Chandler et al.'s (2003) narrative or essentialist methods. Replication in a non-student population is important to establish the reliability of these correlational findings, and also because it affords access to a population that might be characterised by a more nuanced set of place relationships. This replication therefore constitutes the second aim of Study 3.

As well as satisfying these two aims, the development of a valid PIC measure also facilitates investigation of the tentative hypotheses arising from the literature discussed in Chapter Two and Three. As discussed, various theorists from outside and within psychology have suggested there may be positive psychological consequences of perceiving place-based dimensions of identity as characterised by a sense of continuity. This literature has hinted at a potential link between place identity continuity and well-being. Korpela's program of research, for example, has repeatedly highlighted the role of specific place types on well-being measures (Korpela, 1989, Korpela et al., 2008). Although focussed primarily on what he terms 'restorative places', this work signified the genesis of empirical exploration of place as a determinant of mental health outcomes.

Recent work by Oishi and Schimmack (2010) has considered continuity more directly by exploring the connection between residential stability and well-being. Using a longitudinal design they observed that individuals whose lives have been marked by many residential shifts generally have lower well-being, even making a link between mobility and mortality for some groups of people. In their study on the impact of place change, Twigger-Ross and Uzzell (1996) suggested this link might be mediated by perceptions of control, or rather lack of control. They suggest that this control is threatened under circumstances that challenge the maintenance of continuity, for example, in situations of place loss or change.

As well as being associated with feelings of control and stability, places have also been connected with mental health by providing feelings of security. As discussed in Chapter Six, a sense of being at home has been identified as providing feelings of ontological security (e.g., Dupuis & Thorn, 1998), but this ontological security connected with home spaces has also been explicitly linked to mental health and well-being. For example, Padgett (2007) has highlighted ontological security as a key factor distinguishing between individuals with diagnoses of mental illness who are with and without homes, in the context of a New York City re-homing project. These home spaces were linked with the ability to construct a sense of located identity, and with a sense of constancy and confidence in a situated and stable future; both of which suggest that PIC and well-being might be connected.

Indeed, it is this increased sense of identity that seems to be most closely linked to perceptions of continuity. This connection between continuity and identity strength is made explicit in the continuity principle that guides identity construction and maintenance in Breakwell's (1986, 1992, 1994) identity process model, but other literatures have linked perceived continuity, identity strength, and mental health. For example, Fivush et al. (2011) have argued that a sense of family history leads to stronger identification with the family group, and better well-being of family members. For these reasons, and because the link between PIC and place identity strength has already been established in Study 2, the third and final aim of this study will be to explore whether PIC impacts on well-being, and whether this relationship is mediated by place identification.

Method

Design

The study utilised a cross-sectional, survey design with online administration.

Participants

The sample consisted of 611 members of the general public recruited using a snowballing technique via email advertisement across the United Kingdom. This was facilitated by using local and national workplaces and companies, and social media websites. Participants who began the survey but failed to complete it were listwise deleted from the analysis. The total effective sample size then became 470. The sample included 104 males and 294 female, with 71 participants' sex left unspecified. The mean age of participants was 29.52 years ($SD= 10.69$), with ages ranging from 18 to 65 years. The breakdown of nationalities provided was as follows: British: 176; Scottish: 99; English: 13; Irish: 4; Northern Irish: 3; African: 2; Canadian: 6; American: 14; Australian: 1; Kiwi: 3; Indian: 4; Sri Lankan: 2; Pakistani: 1; Malaysian: 2, and the remaining 59 identified themselves as coming from seventeen different countries across Europe, with most being French or German. Finally, 92 participants did not reveal their nationality. Concerning residency, 129 participants stated they were presently residing in the place they answered items with respect to, 263 stated they were not, and 78 did not respond. In terms of total residency, 296 stated they had been resident at some time in their chosen place, 81 had not, and 93 did not respond. The mean length of total residency in chosen places was 11.36 years ($SD=9.29$), ranging from 0 to 52 years.

Measures

The online questionnaire used in this study mirrored that of Study 2, apart from the three main differences: i) only the final PIC and SPIC items remaining following Study 2 were included; ii) the previously explored existential security (ES) variable was removed; and iii) a measure of general well-being was added. Again participants were asked to select the place most significant to them, and answer place-related items with respect to it. They were

also required to specify whether their chosen place was connected to a particular social group, and SPIC items were answered in relation to that group. Full details of each measure are included in the method section of Chapter Six, therefore only details of the new PIC and SPIC measures, and the well-being measure will be provided below.

Place Identity Continuity This was the final 20-item scale derived from Study 2 measuring perceptions of place identity continuity in accordance with three subscales: place referent continuity (PRC; 7 items); place future continuity (PFC; 5 items), and place congruent continuity (PCC; 8 items).

Social Place Identity Continuity This was the final 20-item scale measuring perceptions of place identity continuity in relation to a chosen social group in accordance with three subscales: social place referent continuity (SPRC; 6 items); social place future continuity (SPFC; 6 items), and social place congruent continuity (SPCC; 8 items).

Satisfaction with Life This five-item scale developed and validated by Diener, Emmons, Larsen and Griffin (1985) is a global measure of life satisfaction assessing the cognitive component of subjective well-being. It is measured using a 7-point Likert scale format (1: *totally disagree* – 7: *totally agree*) and higher scores on the scale represent greater satisfaction. The scale has been found to converge with more detailed measures of subjective well-being (Pavot, Diener, Colvin, & Sandvik, 1991), and it is thus taken to be valid measure of well-being.

The remaining measures duplicated from Study 2 are: PCP: Perceived Continuity of Place; Place Attachment (PA); Place Identity (PI); Mobility Beliefs (MB); Perceived Personal Discontinuity (PPD); Identity Continuity Strategy (ICS). The format of each measure was the same as in the previous study, with all items corresponding to a 7-point Likert scale format (1: *totally disagree* – 7: *totally agree*) apart from ICS which required a choice of

response corresponding to either an essentialist or narrativist method of constructing identity continuity. The questionnaire also included the same demographic questions as the Study 2 questionnaire, identifying the age, sex, and nationality of participants. Again, participants were also asked to indicate if they currently resided in their chosen place, and if so, for how long. They were also asked to indicate if they had ever lived in the place chosen, and if so, for how long. A copy of only the satisfaction with life measure is included in Appendix Five, as all other measures have been included in Appendix Four within the Study 2 questionnaire.

Procedure

The questionnaire items were again administered using the SurveyMonkey software for online data collection facilitating the collection of a large amount of data from a wide general public population. As before, participants were required to read a study information sheet and to provide informed consent in line with ethical requirements, before clicking to commence the survey. Participants took part anonymously, although they had the option of leaving an email address to be entered in to a prize draw for an online store voucher worth £30. They were assured their data would be stored securely and confidentially, and were informed their participation was voluntary, with no direct monetary reward for taking part. Two versions of the survey were posted online so that social and personal PIC items could be counterbalanced. Participants were provided with a link connected to a University of Dundee webpage that randomly directed participants to either one of the two versions of the questionnaire. Once the online survey had been active long enough to gain a sufficient sample for cross-validation of the PIC measures, the survey link was closed and the data were downloaded for analysis.

Results

Data Screening & Descriptive Statistics

First, all negatively coded items were reversed so that all items on each scale represented stronger endorsement of that variable. Composite variables were then created and the usual checks for normality of distribution were conducted. As in Study 2, inspection of the histograms for each variable suggested that some were negatively skewed with most values clustering nearer the positive end of the scales. This was the case for the following variables: PRC, PCC, SPRC, SPCC, PI, and PCP. Again, the mobility beliefs (MB) variable was slightly positively skewed with most values clustering just below the mid-point. Values for skew and kurtosis for each of these variables were above the critical value of 3.75. However, transformation of the data was again not performed due to the large sample size ($N > 200$), and the robustness of the estimation methods and non-parametric bootstrapping to be used in subsequent analyses (Field, 2009; Tabachnick & Fidell, 2007). The nature of the scores is reflected in the means and standard deviations of each scale provided below in Table 7.2. It is likely that positive scores reflect the method of asking participants to choose significant places contributing to the generally positive endorsement of items, and therefore any issues of skew make theoretical sense. As in Study 2, there was no evidence of multicollinearity in the variables as all correlations between variables were below .90, VIF values for all variables were all below 10, and Tolerance values were all above .10. Examination of randomly tested standardised residual scatterplots showed relationships between variables to be generally linear and no with evidence of homoscedasticity. Examination of the boxplots for each variable showed each included no extreme outlying values, and any outlying values represented possible scores therefore not reflecting errors in data entry. All data points were therefore retained in the analysis (Pallant, 2001).

As the presentation of social and personal place identity continuity items was counterbalanced in this study to check for order effects, it was necessary to check for differences in mean scores according to questionnaire version. A series of independent t-tests showed no significant differences between groups on any of the variables, so the results from both groups were subsequently collapsed for analysis.

Cross-validation of the PIC Scales

The first set of analyses conducted involved the cross-validation of the PIC and SPIC scales. For the purposes of confirmatory factor analysis, missing data relating to the place identity continuity items (11.89%) were imputed in the LISREL program using maximum likelihood estimations (LISREL 8.8; Jöreskog & Sörbom, 2004), to enable use of goodness-of-fit indices that are sensitive to missing data. To confirm the dimensionality and structure of the PIC and SPIC factor structures, measurement models corresponding to those developed in Study 2 were constructed and their fit with the general public data was assessed using the same fit indices. This CFA was again conducted using the AMOS 17.0 program (Arbuckle, 2008) for structural equation modelling (SEM).

CFA analysis indicated that both the PIC and SPIC measurement models displayed a satisfactory fit with the observed data (see Table 7.1 below for results on all goodness-of-fit indices). Again, the chi-squared statistic was significant indicating a difference between the measurement model and the observed data. However, as the sample in this study was considerable larger than in Study 2, it was expected that this would be the case. As previously argued, it is unlikely that a non-significant chi-squared result would be achieved under these conditions. Therefore, it is acceptable to judge the success of the cross-validation of the scales on the remaining variety of goodness-of-fit indices observed in Table 7.1 (Brown, 2006;

MacCallum & Austin, 2000). Both 20-item models with standardised beta regression coefficients are displayed below in Figures 7.1 and 7.2.

Table 7.1 Goodness-of-fit Indices for the Three-factor PIC Model and Three-factor SPIC Model

	<i>N</i>	χ^2	df	CMIN/DF	NFI	CFI	RMSEA
Study 3 PIC model	20	575.53*	163	3.53	.91	.93	.07
Study 3 SPIC model	20	493.21*	165	2.99	.92	.94	.07

Note: * $p < 0.0001$, *N*= Items; NFI= Normative Fit Index; CFI= Comparative Fit Index; RMSEA= Root Mean Square of Error Approximation.

Correlations between Place Identity Continuity Subscales

Just as in Study 2, the PIC model in Figure 7.1 showed there was a moderately strong correlation between perceptions of PFC and PCC ($r = .46$; $p < .01$), but no significant relationship between PRC and PCC. However, for this population there was a slightly stronger relationship between PRC and PFC ($r = .24$; $p < .01$). Concerning the SPIC measures, the moderate relationship between SPRC and SPFC was also found in this study ($r = .30$; $p < .01$), as was the low but significant positive correlation between SPRC and SPCC ($r = .19$; $p < .01$). The positive relationship between SPCC and SPFC was also found in this study but the strength of the association was slightly weaker ($r = .56$; $p < .01$).

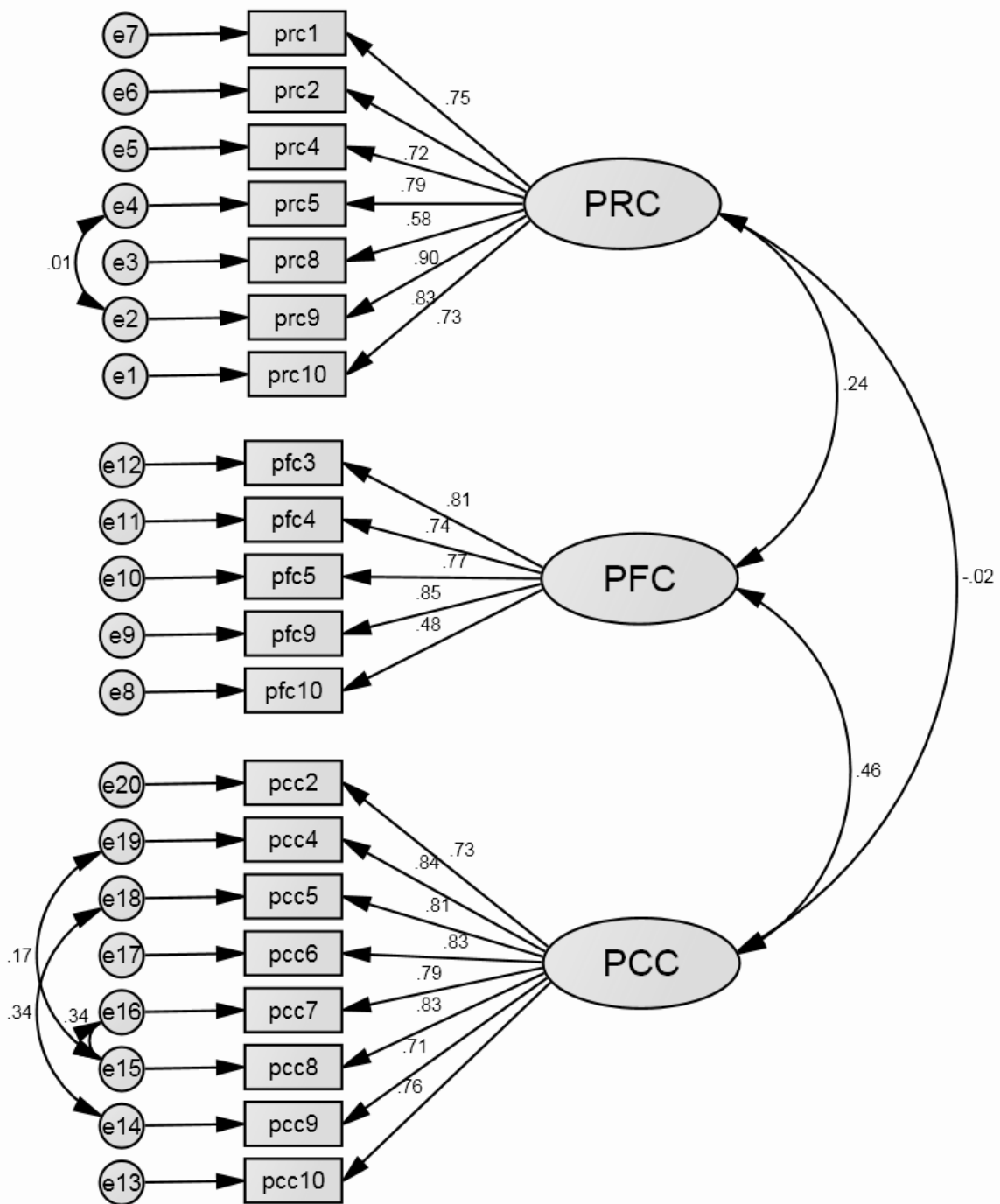

Figure 7.1 Results of CFA for the Cross-validated 20-item Three-factor PIC Model

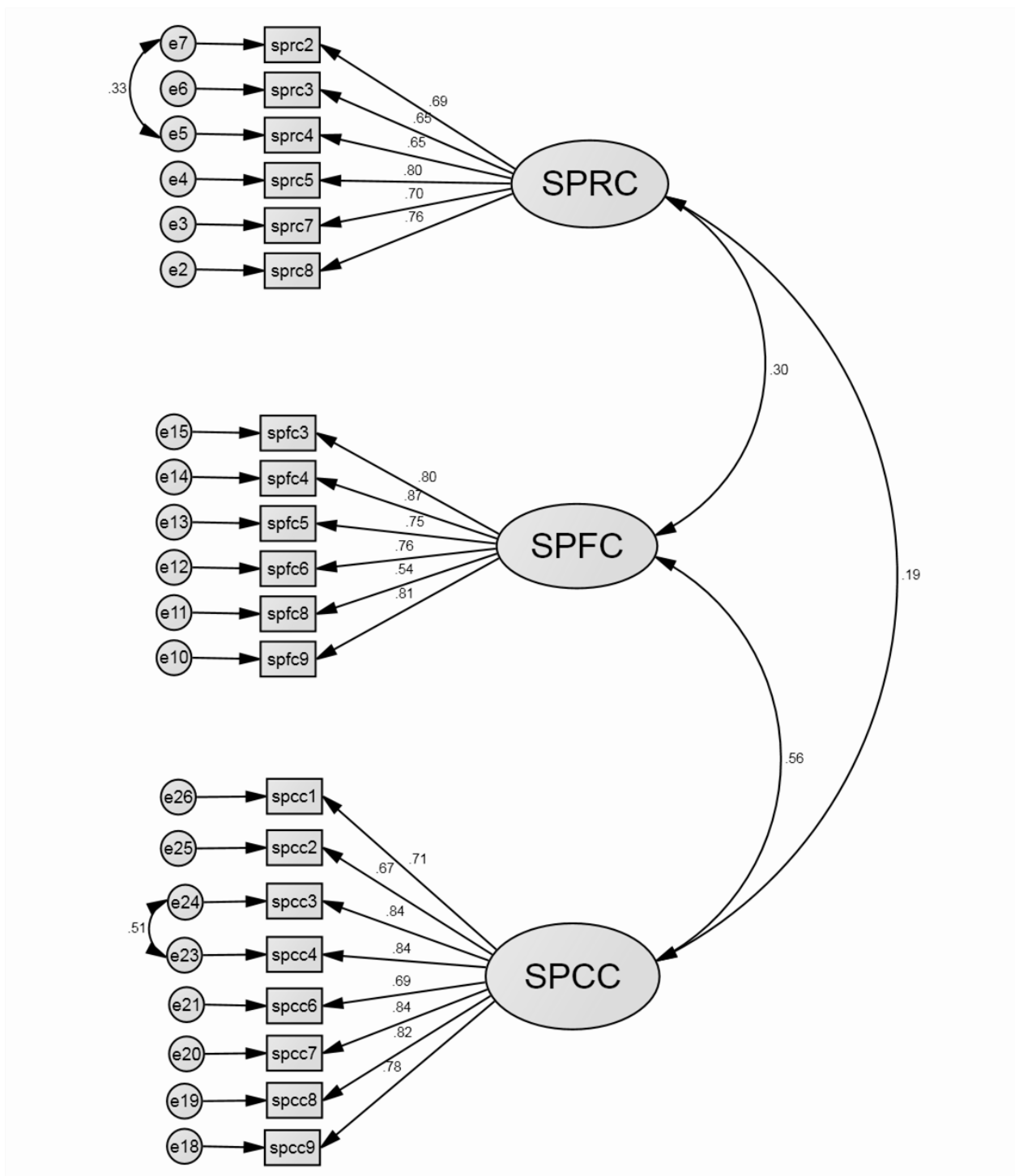

Figure 7.2 Results of CFA Analysis for the Cross-validated 20-item Three-factor SPIC Model

PIC and Demographic Measures

Concerning the primary demographic variables, there were both differences and similarities between the student and general public samples of Study 2 and 3. In the present study there were no significant differences across variables according to sex apart from one: females reported higher perceptions of PFC ($t(396) = -2.37; p < .05$), indicating they were more likely to associate chosen places with a sense of future place identity. There were no significant differences on any variables according to whether participants were parents, and no significant correlations between any of the PIC or SPIC variables and the age of the participants, even with the broader age range characteristic of this sample.

Length of residency was found to be positively associated with all place identity continuity variables, but only two of these reached significant: PRC ($r = .34; p < .01$) and SPFC ($r = .31; p < .01$). Therefore, in this sample increased residency was associated with place being connected more strongly to individual past and an anticipated group future. The group most commonly chosen in this study was again the family, following by friends. In addition, if participants indicated they lived in the place they responded in relation to, their scores on PCC ($t(390) = 2.91; p < .01$) and SPCC ($t(390) = 2.02; p < .05$) were significantly higher. In contrast, scores on PRC ($t(390) = -6.51; p < .01$) and SPRC ($t(390) = -4.59; p < .01$), were higher for those who indicated they did not live in their chosen place, suggesting longer histories were characteristic of places participants used to live. This was confirmed by higher scores for PRC ($t(375) = 2.72; p < .01$) and SPFC ($t(375) = 1.98; p < .05$) for those who indicated that had once lived in their chosen place, compared with those who never lived in their chosen place. Also, the difference between those who had once lived in their place compared with those who had never lived in their chosen place approached significance for

both PFC ($p=.07$) and SPRC ($p=.08$), again with higher scores for those who had lived in the place at some time in their past.

PIC and Place-related Measures

In comparison to the previous study, not all dimensions of place identity continuity were positively related to place attachment (PA) as the relationship between PRC and place attachment did not reach significance ($r = .09$; $p = \text{NS}$). The SPRC variable was weakly but significantly associated with place attachment ($r = .18$; $p < .01$). In contrast, both social and personal place future and place congruent continuity variables were more strongly related to place attachment ($r = .48-.71$; $p < .01$). Again, place identity continuity was related to perceptions of the physical continuity of the chosen place (PCP), and unlike Study 2 this was the case for all personal and social dimensions with correlations strength varying between weak to moderate ($r = .11$; $p < .05 - r = -.42$; $p < .01$), including the PRC and SPRC variables that were not significant in Study 2. As in Study 2, all dimensions of place identity continuity – both social and personal – were negatively related to beliefs regarding the benefits of residential mobility (MB) ($r = -.14 - -.40$; $p < .01$). The relationships between perceived personal discontinuity (PPD) were all significant and negative in this study – including the PRC variables that were not present in Study 2 – although again they were not particularly strong ($r = -.14 - -.25$; $p < .01$). Finally, as in Study 2, all dimensions of place identity continuity, for both personal and social place relationships, were positively related to place identity strength ($r = .33 - .60$; $p < .01$), with the strongest connections with place future and place congruent continuity dimensions.

Table 7.2 *Correlations and Descriptive Statistics for Study 3 Variables*

Variables	1	2	3	4	5	6	7	8	9	10	11	12
1. PRC	--											
2. PFC	.24**	--										
3. PCC	-.02	.46**	--									
4. SPRC	.60**	.24**	.08	--								
5. SPFC	.19**	.63**	.38**	.30**	--							
6. SPCC	.04	.40**	.71**	.19**	.56**	--						
7. PA	.09	.56**	.71**	.18*	.48**	.54**	--					
8. PI	.35**	.56**	.60**	.33**	.42**	.46**	.73**	--				
9. PCP	.16*	.35**	.26**	.11*	.42**	.30**	.34**	.27**	--			
10. SWL	-.06	.13*	.26**	-.06	.09	.21**	.26**	.22**	.15**	--		
11. MB	-.14**	-.31**	-.40**	-.18**	-.20**	-.27**	-.44**	-.34**	-.28**	-.16**	--	
12. PPD	-.16**	-.16**	-.26**	-.15**	-.13**	-.23**	-.25**	-.19**	-.13**	-.33**	.33**	--
Mean	5.74	4.89	5.34	5.76	4.74	5.53	5.12	5.72	5.01	4.84	3.23	4.01
SD	1.21	1.30	1.27	1.09	1.35	1.01	.97	.95	1.13	1.34	.89	1.41
α	.90	.84	.93	.86	.88	.91	.85	.91	.86	.90	.73	.72

Note: * $p < .05$; ** $p < .01$. PRC: Place Referent Continuity; PFC: Place Future Continuity; PCC: Place Congruent Continuity; SPRC: Social Place Referent Continuity SPFC: Social Place Future Continuity; SPCC: Social Place Congruent Continuity; PA: Place Attachment; PI: Place identity; MB: Mobility Beliefs; SWL: Satisfaction with Life, and PCP: Perceived Continuity of Place; PPD: Perceived Personal Discontinuity.

Before exploring the impact of place identity continuity on well-being it was necessary to establish the impact of identity continuity strategy on place identity continuity with this general public sample. A series of independent t-tests were conducted to analyse the differences between those that construct self continuity in accordance with narrative strategies (as a developing and on-going life-story with interconnected phases) compared with those that construct it in accordance with an essentialist strategy (with reference to unchanging inner essences). Unlike in Study 2, where no significant differences in PIC or SPIC were found across conditions despite all mean differences being in the expected direction, significant results were found in this study.

Specifically, those selecting essentialist continuity strategies reported higher place congruent continuity ($t(392) = 2.18; p < .05$) and social place congruent continuity ($t(392) = 2.23; p < .05$).

Those who realise their sense of self continuity via fixed aspects of self were therefore more likely to rate their chosen significant place as congruent with their identity. This was accompanied by increased ratings of place attachment for those with an essentialist identity continuity strategy ($t(388) = 2.43; p < .05$). As in Study 2, those with a narrative-based continuity strategy were more likely to endorse stronger views about the value of mobility ($t(391) = -2.95; p < .01$).

Identity Continuity and Well-being: Mediation Analyses

The correlational relationships presented in Table 7.2 suggest there is a relationship between PIC and SWL, but it is important to understand the means by which PIC might have an impact on this well-being. One way this influence might be carried is by the strengthening of the relationships between person and place: the process of identification. Mediation models assessing at the impact of each dimension of PIC and SPIC upon SWL mediated by PI were therefore tested. Preacher and Hayes' (2008) method of testing indirect effects was employed as it is considered superior to Baron and Kenny's (1986) causal steps approach to establishing mediation in terms of

its power to detect the existence of effects. This is due to its use of non-parametric bootstrapping techniques, which are more robust than the alternative regression-based techniques traditionally used. This bootstrapping involves extracting a large number of randomly selected samples from the data associated with each variable to construct confidence intervals to establish the significance of the indirect effects. If the interval between the lower and upper confidence interval values includes zero, then the effect of the third (mediator) variable is no different than would be expected by chance, and therefore the indirect effect¹² is not significant (Wright & Field, 2009). As well as providing bias-corrected results, using this approach it is still possible to estimate the significance of indirect effects from X to Y through a mediator variable when one of the paths in the model is not significant, unlike the tradition Baron and Kenny method, due to the simultaneous estimation of effects as opposed to the their stepwise approach (Hayes, 2009).

The mediation models constructed to test whether place identity continuity impacted on satisfaction with life by increasing place identity strength are represented below in Figure 7.3¹³. Using bias corrected 95% confidence intervals and 5000 bootstrap samples, the confidence interval for the effect size of the indirect path from PRC through place identity was .06 to .16 and did not include zero, indicating it was a significant mediator; the confidence interval for the effect size of the indirect path from PFC through place identity was .05 to .20 and did not include zero, indicating it too was a significant mediator; and the confidence interval for the effect size of the indirect path from PCC through place identity was -.02 to .13 and included zero, indicating it was not a significant mediator. Thus, in line with predictions, place identity mediated the relationships

¹² Indirect effects refer to the *ab* path in simple mediation models going from the independent variable (X) through the mediator (M) to the dependent variable (Y). This corresponds to the total effect (c) of X on Y that does not control for the mediator, minus the direct effect (c') of X on Y.

¹³ Coefficients displayed in Figure 7.3 and 7.4 are unstandardized regression coefficients as the Preacher and Hayes (2008) method does not produce standardised beta coefficients.

between PIC and SWL. However, this was only for the place referent and place future dimensions, and not for place congruent continuity, which appears to exert its own independent effects.

There are some key features of these indirect relationships that should be acknowledged here, particularly as each PIC dimension involves distinct patterns of correlations. It could be argued that the indirect relationship from place future continuity to satisfaction with life through place identity is the most straightforward mediated relationship. That is, the total effect of PFC on SWL was significant ($b = .13; p < .05$) but when the effect of the place identity was controlled for this significance disappeared ($b = .01; p = \text{NS}$), and as the bootstrap results indicate, this indirect effect was significant. In contrast, there was no significant indirect effect from PCC to SWL through place identity. Here the total effect was significant ($b = .28; p < .01$), but the direct effect between PCC and SWL was also significant and only slightly reduced when place identity was controlled for ($b = .22; p < .01$).

Perhaps the most interesting indirect relationship was between place referent continuity and satisfaction with life with the addition of place identity. In this situation the non-significant total effect relationship from PRC to SWL ($b = -.07; p = \text{NS}$) became a significant negative relationship when place identity was added to the model ($b = -.17; p < .01$). This is indicative of a suppressor effect, which is defined as a third variable relationship mathematically identical to mediation but characterised by a specific set of relationships where the third variable – place identity in this case – suppresses the real effects of the predictor on the criterion variable (MacKinnon, Krull & Lockwood, 2000). In this case, the bootstrap results showed that the suppressor effect was significant and that when the suppressor variable was accounted for PRC actually impacted negatively on well-being.

A) Place Referent Continuity

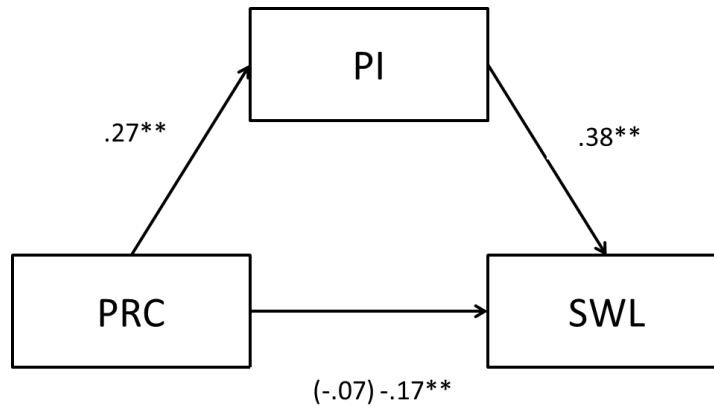

B) Place Future Continuity

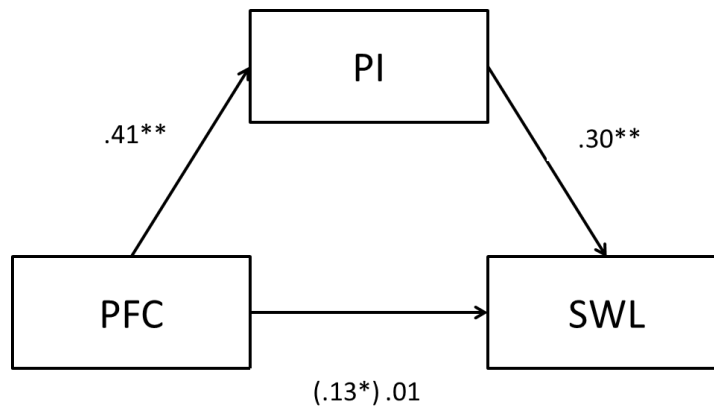

C) Place Congruent Continuity

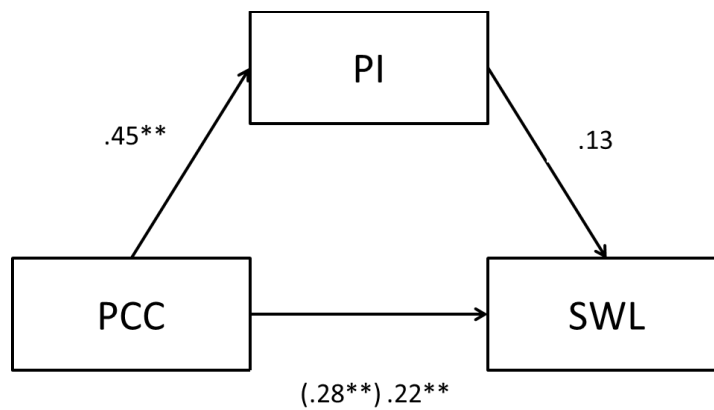
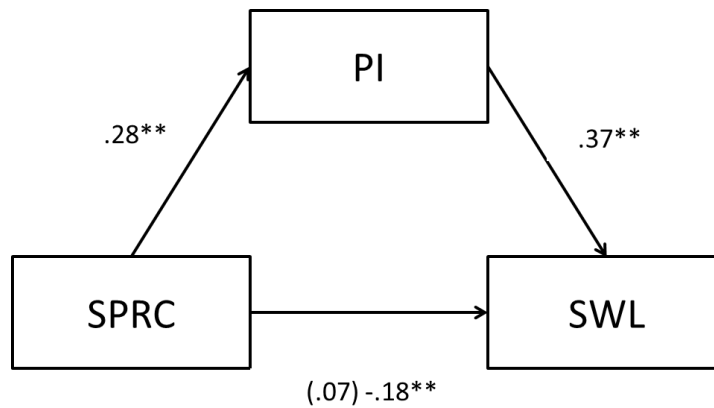

Figure 7.3 Mediation Models for the Effects of Place Identity Continuity Dimensions on Satisfaction with Life Mediated by Place Identity. (N=338; * $p < .05$; ** $p < .01$)

A series of mediation models were also constructed to test whether social place identity continuity impacted on satisfaction with life by increasing place identity strength (see Figure 7.4, below). Using bias corrected 95% confidence intervals and 5000 bootstrap samples, the confidence interval for the effect size of the indirect path from SPRC through place identity was .06 to .17 and did not include zero, indicating it was a significant mediator; the confidence interval for the effect size of the indirect path from SPFC through place identity was .04 to .14 and did not include zero, indicating it too was a significant mediator; and the confidence interval for the effect size of the indirect path from SPCC through place identity was .02 to .17 and did not include zero, indicating it was also a significant mediator. Thus, in line with predictions, place identity mediated the relationships between SPIC and SWL for all dimensions, although this is only a partial mediation for social place congruent continuity, which appears to exert its own independent effects on satisfaction with life.

Again, exploring the specific nature of the impact of each variable is important. As with the PFC variable, the indirect relationship from SPFC to SWL through place identity is the most straightforward mediation relationship. That is, although the total effect of SPFC on SWL was not significant ($b = .10$; $p=NS$), when the effect of the place identity was controlled for the coefficient neared zero ($b = .01$; $p=NS$), and as the bootstrapping results indicate, this mediated indirect effect was significant. In contrast to PCC, there was a significant indirect effect from SPCC to SWL through place identity, although again both the total effect ($b = .29$; $p<.01$) and the direct effect between SPCC and SWL were significant ($b = .20$; $p<.01$). This therefore indicated a significant partial mediation.

A) Social Place Referent Continuity



B) Social Place Future Continuity

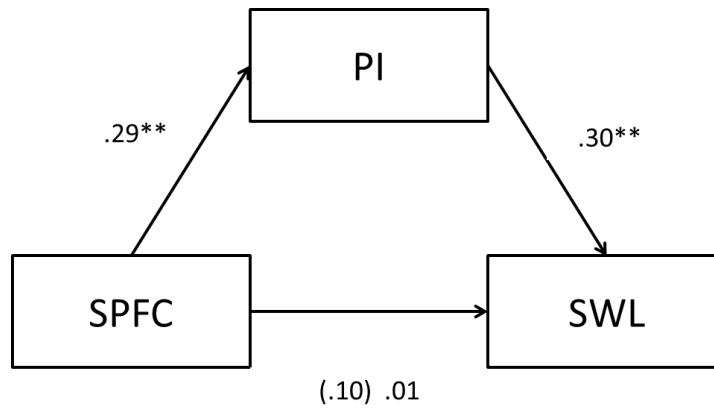

C) Social Place Congruent Continuity

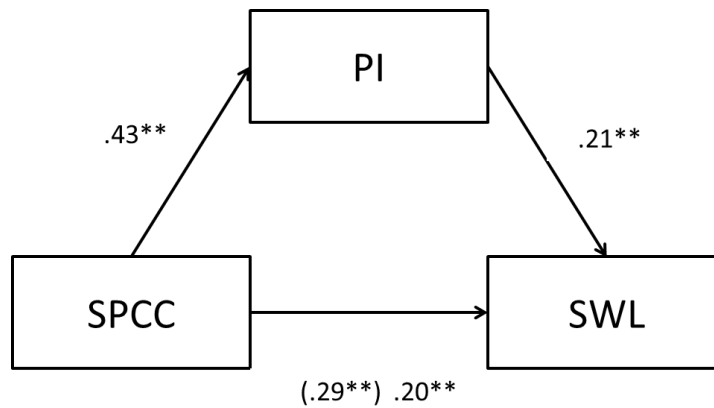

Figure 7.4 Mediation Models for the Effects of Social Place Identity Continuity Dimensions on Satisfaction with Life Mediated by Place Identity. (N=338; * $p < .05$; ** $p < .01$)

However, as for the PRC variable, there appeared to be a suppressor effect of place identity on the link between SPRC and SWL. In this situation, the non-significant total effect relationship from SPRC to SWL ($b = -.07$; $p=NS$) became a significant negative relationship when place identity was controlled for ($b = -.18$; $p<.01$). In this case, the bootstrapping results showed that the suppressor effect was significant and that when the suppressor variable was accounted for SPRC also impacted negatively on this measure of well-being.

Discussion

This study had three specific aims. Firstly, to provide a cross-validation of the newly developed PIC and SPIC scales in a general public sample to confirm both the validity and the three-dimensional structures of the scales. Secondly, the study was aimed at replicating the results concerning the relationships between place identity continuity and other place relevant variables. Finally, the study was aimed at pinpointing the processes by which perceptions of place identity continuity might exert their impact on well-being, specifically by exploring the impact of a third variable in that relationship: place identity. Each of these tasks will be discussed in turn.

Regarding the first aim, the study successfully demonstrated the validity of the scale for an alternative population by replicating the confirmatory factor analytic results from Study 2, and showing that the proposed scale structures adequately fit this new data set. This suggests that the scales can be used with confidence in future studies in different populations, at least within this cultural context. Importantly, similar relationships were also found between the subscales such that the dimensions of place future continuity and place congruent continuity were closely linked, the place future and place referent continuity dimensions were slightly linked, and finally that

place referent continuity and place congruent continuity were not related – especially for the personal version of the scale. These results suggest that the results from Study 2 possess some reliability due to their replication.

The second aim of the study, to provide support for the correlational results found in Study 2, was also successfully achieved. Although there were some minor variations in the direction and nature of effects between studies, results were generally replicated. The importance of length of residency was again found in this study with some important variations in line with whether individuals either lived in, or had once lived in, the place they chose to answer with respect to. Generally this meant that increased continuity ratings were found for those who had stayed in places for longer, but it was more common for participants to perceive higher place referent continuity with a place they had resided in in the past, and more place future and congruent continuity with a place they currently lived in. It was again found that place identity continuity was related to perceptions of the physical continuity of places, with slightly stronger associations observed in this general public sample.

As in Study 2, place identity continuity was negatively associated with perceptions of personal discontinuity, although again this was only a relatively weak association. This perhaps suggests that personal continuity might be derived from other sources of identity, and accords with studies that have highlighted the multiple identity sources capable of providing subjective continuity (e.g., Burris & Rempel, 2008). In addition, place identity continuity ratings were also negatively associated with positive views of residential mobility, just as was found in Study 2, indicating that this was a reliable effect. This finding may indicate that those who value mobility are less likely to consider place identities in this temporal fashion, they may have moved around more often making perceptions of place identity continuity less likely, as well as less important, or

they may consider a temporal connection with the places as limiting travel opportunities. Indeed results showed participants with positive views about mobility are also less likely to become attached to places, suggesting there is significant variability in the propensity to intimately connect with place. These relationships between place identity continuity and views on mobility were evident in the interview data presented in Study 1. For example, several interviewees expressed a desire to make a break from past places to travel or find more suitable places. Moreover, for those who willingly chose to move, the notion of mobility was often bound up with self-development and achievement.

This study also replicated the results of Study 2 by showing that place identity continuity is related to place attachment. In this study, it was also found that place congruent and place future continuity, for both personal and social scales, were more strongly linked with place attachment, just as was the case in the student sample. Interestingly, this distinct pattern of correlations was also observed between PIC and SPIC dimensions and place identity in this study. That is, all dimensions were positively related to place identity, but this relationship was again far more pronounced for perceptions of future place identity and a sense of congruent place identity. Both these sets of results demonstrated the reliability of findings in relation to place attachment and place identity, but importantly they also demonstrated the importance of the new future-orientated approach to place identity conceptions, unique to this program of research.

Finally, the study also sought to clarify the potential effects on PIC of identity continuity strategy, to extend the qualitative work of Michael Chandler and colleagues demonstrating the links between how continuity is maintained and youth suicide (Chandler & Lalonde, 1998; Chandler et al., 2003; Chandler & Proulx, 2008). In Study 2, no differences in terms of place identity continuity or social place identity continuity were found according to whether students

indicated that they constructed their identity in accordance with an essentialist, 'enduring entity' account, or whether they chose a more narrative, 'on-going story' account. However, it was observed that narrative strategies resulted in stronger positive views about mobility and stronger perceptions of personal discontinuity.

In this study, as in Study 2, those with a narrative continuity strategy also expressed more positive views about residential mobility, but unlike in Study 2 they did not perceive more personal discontinuity. However, a finding unique to this study showed those with an essential continuity strategy expressed higher place attachment and stronger perceptions of place congruent continuity, for both themselves and the group identity they associated with their chosen place. These findings indicated that in a general public sample those with essentialist means of maintaining a sense of continuity were less likely to endorse mobility and were more attached to the places they identify with. Moreover, it seems they were more likely to have place relationships that they felt were congruent with their sense of self. In sum, it seems that identity continuity strategy may be one means by which the nuances of place relationships and expressions of place identity continuity might be accounted for.

Concerning the third and final aim of the study, to explore the processes underlying the relationship between place identity continuity and well-being, mediation analyses did show that increased place identity is responsible for some of the effects. More specifically, it was found that both personal and social place future continuity dimensions exerted their positive impact on satisfaction with life by increasing place identity strength. The positive effect of social place congruent continuity on well-being was also partially mediated by place identity but this was not the case for personal place congruent continuity, which exerted an independent effect. These findings suggest there are psychological benefits associated with a place identity that can be

extended into the future, because it increases a sense of connection and identification with that chosen place. In addition, identifying with a place felt to be congruent with the self positively and directly influences the well-being of the individual.

These findings suggest that, just as literature discussed in Chapter One has suggested, personal continuity is related to positive mental health outcomes (e.g., Chandler et al., 2003; Lampinen et al., 2004), so it seems place identity continuity is also connected with well-being. However, the complexities of this relationship require further examination, which might be facilitated by a secondary stage of data analysis from the current datasets. More specifically it is necessary to explore why place referent continuity – both personal and social – seem to exert negative effects on well-being. It is quite possible that this could be to do with the distinct residential patterns in selected places that were associated with perceptions of place referent continuity. It has been noted that those who rate PRC and SPRC more strongly tend to be answering with respect to places they used to live. However, it may be that for the individuals who had chosen to answer with respect to a new place of residence – potentially characterised by a sense of congruency and where they can envisage a future – it might be less possible or crucial to construct a sense of past continuity in this place.

Alternatively, it might be that having a sense that a place is connected to a past version of self is possible but that it could impact negatively on well-being because that connection is unwelcome. This might be because of the content of that past relationship (e.g., negative memories and experiences), or because the past relationship with that place is viewed as constrictive (cf. P6's account in Study 1). It makes sense that this relationship would be masked by the positive effects of place identity strength, which cancel out the negative effects of PRC, as seen in the above suppressor effects. Increased identification with that chosen place may

conceivably mask those negative effects because this increased identification impacts *positively* on well-being. Deciding between these possible explanations remains an important task for future studies that could be addressed with additional controls for residential length and type, and measures of the valence of past place-related experiences.

To help assess the validity of the first explanation, it might be useful to explore the effects of residential status and history on these effects by controlling the nature of place choice in future studies. Unfortunately this variation in place choice is a product of the study design, but one option to explore this situation could be a moderated mediation design. This approach has been described by Preacher, Rucker, and Hayes (2007) and involves observing whether the mediated relationship is altered according to different levels of a fourth moderating variable. In this case, it is plausible that residential circumstances might be this fourth variable, such that for those that answer with respect to places that they currently choose to live in, or have lived in for an extended period, place referent continuity is important and may actually impact upon *positively* on satisfaction with life, despite these effects being masked in the present study. This presents opportunities for further study and more complex place-type specific analyses.

Conclusions

As well as providing the necessary replications of effects from Study 2 to support the reliability and validity of earlier findings, this study has explored the underlying mechanisms linking perceptions of place identity continuity and well-being. Many authors have provided different means to pick apart the complexities of relationships between people, place, and mental health. In their study, discussed in the introduction of this chapter, Oishi and Schimack (2010) attempted to determine whether variations in these relationships could be accounted for in terms of personality variables such as extraversion and introversion. The results of this study have

suggested another way to dissect and understand the connections between people and places might be to identify the strategies individuals use to construct their own sense of continuity. It is vital to isolate the impact of residential patterns and place identity strength to fully understand when and why perceptions of place identity continuity might occur. Each of these analytic paths present opportunities for valuable further study, but the remainder of this thesis will be focussed upon examining another potential determinant of place identity perceptions: social context. In doing this, these final analyses presented in Chapter Eight will address one of the overarching aims of this thesis: the application of social identity processes to the understanding of place identity.

CHAPTER EIGHT

Study 4: Social Identity and Place Identity Continuity

Introduction

The preceding chapters have reported studies addressing the initial aims of this thesis, namely, to explore the nature, structure, and psychological significance of place identity continuity. A social psychological approach has been used to achieve these ends, but beyond the inclusion of a collective version of the PIC scale and the theoretical bedrock influencing the study aims and designs, the social psychological dimensions of place relationships remain somewhat uncharted. With this in mind the present study sought to address the final aims of the research program: to bring together environmental and social psychological theories of identity by specifically exploring the effects of social categorisation on perceptions of place identity continuity.

Study 4 therefore marks a move towards an experimental paradigm concerned with the integration of place identity research with a social identity perspective. As discussed in previous chapters, this is a combinatory move that has been frequently invited by authors whose interests span both disciplines (Dixon & Durrheim, 2000; Hauge, 2007; Lalli, 1992; Stedman, 2002; Twigger-Ross et al., 2003). However, despite arguments that expound the necessity of dynamic and interactive accounts of place identity to complement those found in other theories of identity, this path is still largely not ventured (Devine-Wright & Clayton, 2010). This means personality-based or developmentally-defined views of place-identity (e.g., Proshansky, 1978; Proshansky et al., 1983) still commonly dominate and are frequently used to explain place-related behaviour.

Frieze, Hansen, and Boneva (2006), for example, have put forward the idea of migrant personality types. Specifically, they suggest the propensity to migrate is due to a collection of ‘push and pull’ attitudinal factors relating to issues such as job prospects or the desire to have children. These are said to constitute a personality characteristic postulated as responsible for variation in the likelihood to break away from places of origin. However it is conceivable that social factors, such as self-categorisation, might influence these attitudes and provide more useful means of understanding mobility and weaker place identification. In doing so this would help provide the contextual interpretation of place identity which Proshansky originally sought to advance (see Proshansky et al., 1983, p.61). It would also support an understanding of place identity consonant with the context dependent definition of identity given in Identity Process Theory (Breakwell, 1992, 1994) and Self-categorisation Theory (SCT; Turner et al., 1987). This study therefore sought to examine the contextual elements of place identity by questioning whether this aspect of self is variably perceived dependent on the situational context and contextually-relevant social dimensions of participants’ identities.

A recent body of social psychological literature has laid the ground for this analysis of place identity by challenging the classical distinction between the variable social self, that changes as a function of multiple group identifications, and the enduring trait-based personal self (Reynolds et al., 2010). Various studies have explored ‘fixed’ personality characteristics such as right-wing authoritarianism and social dominance orientation by demonstrating variability in the expression of these characteristics resulting from social identity manipulations. Therefore, challenging existing notions of their ‘stability’ and predictive power (e.g., Reynolds, Turner, Haslam, Ryan, Bizumic, & Subašić, 2007; Wilson & Liu, 2003). Thus far, even characteristics central to dominant theories of personality, such as neuroticism, have been shown to vary according to social identity conditions (Reynolds, Turner, Branscombe, Mavor, Subašić & Bizumic, 2012).

This body of work offers a potential strategy for analysing the variability of perceptions of place identity continuity by drawing directly upon central processes within the social identity perspective. A perspective which has demonstrated that the self is made up, not only of individual characteristics, but also of the groups we feel we belong to (Tajfel & Turner, 1986). Self-categorization Theory (Turner, 1985; Turner et al., 1987) has added to this literature by defining the perceptual and cognitive processes involved in identifying with particular social categories and has elaborating on the role of social identity salience. This notion – a key feature of the studies described above – involves the self as defined in terms of shared group memberships and is implicated in processes of identification, intragroup behaviour, and intergroup phenomena (Oakes, 1987; Onorato & Turner, 2002).

Social identity salience leads to self-stereotyping processes that have behavioural and attitudinal consequences consonant with the content of the social identification in question. This means that qualitatively different shifts in perception and action can be observed according to the nature of currently salient identities because each identity encompasses its own set of norms and values. As these are perceived to be consensually shared by group members, identification leads to expectations of agreement on identity relevant issues (Turner & Reynolds, 2001; Haslam, Oakes, Reynolds & Turner, 1999). Social identity salience is governing by a combination of perceiver readiness and processes of fit between social categories and perceived reality, as governed by the meta-contrast principle laid out in SCT (Haslam, et al., 1999; Oakes, 1987). In this manner, features of the social environment and the comparative context lead to the salience of particular social identities in particular circumstances. However, as seen in the earlier studies, social identity salience can also be manipulated experimentally by altering the accessibility of specific social identities through enhancing perceiver readiness. This is done by increasing individuals' awareness of their membership in particular social categories (Haslam, 2004).

As well as carving out a contextually-oriented account of place identity perceptions, using an approach of this type also builds upon the results of Study 1. Inductive coding of interview data in this study led to the identification of variance within some participants' accounts of their place identities, and their sense of perceived continuity in relation to those place identities. As discussed in Chapter Five, these variations were often couched in terms of development or life-stage, where particular patterns of residency and temporal connection to place were either more or less appropriate. However, it was also noted that the perceived continuity of place identities, be that in terms of its connection to individual or group past, present fit, or future plans, seemed to vary according to whether participants were discussing their family identity. In contrast, when discussing their identity as a student, young person, or career-minded individual, places like the childhood home, hometown, or country were described as less significant. Instead, some merit was associated with travel and the collection of new, or more identity-relevant, place experiences. The challenge emerging from this study was the explanation of this observed variance. Just as social identity analyses challenged accounts that explained away variability in personality traits as due to error variance (Reynolds et al., 2012), so it might be possible to account for variance in PIC using social categorisation.

These arguments led to the design of a study that involved manipulating the salience of two specific social identities, each thought to be differentially related to the hometown. This marked a move away from looking at the endorsement of place identity continuity in general to looking at the effects of social categorisation on a specific place identity. In correspondence with observations of the interview data, the two social identities selected were 'student' and 'family member'. Each identity was primed experimentally across two conditions to increase identity salience before participants rated their own hometown place identity on the PIC measures.

In the present study it was expected that by priming two contrasting social identities, each differentially associated with the importance and relevance of stable, bounded relationships with place, differences in ratings of perceived identity continuity would be observed between groups. Specifically, based on the results of Study 1, it was predicted that priming participants with family identity would lead to higher scores on the place identity continuity scale due to the observed association between the family group and a sense of home, as well as the acquired history and anticipated future potentially associated with that place.

In contrast, it was expected that priming student identity would lead to lower levels of perceived place identity continuity as the student role commonly represented a breakaway from the hometown and a new life-stage, coupled with a common desire to travel and experience new places. Measures of age and social identification were included as control measures, as well as a number of additional measures relating to the strength and significance of the place-person relationship. These latter measures were included to explore any potential moderating influences they may have on the relationship between social identity and place-identity continuity.

Method

Design

The study employed an independent samples experimental design with two randomly-assigned conditions: student identity salience and family identity salience. Place identity continuity measures served as dependent variables, and key place identity measures were included as potential moderating variables.

Participants

The sample consisted of 106 undergraduate student participants from the University of Dundee, recruited via the university research participation scheme in exchange for course credit. Participants who failed to complete the identity salience prime questionnaire in full were listwise deleted from the analysis. One participant was also deleted because they answered with reference to their house instead of their hometown. It was necessary to delete these cases from the analyses to avoid invalidating the results, although this did leave an unequal number of participants in each condition. The total effective sample size after deletion of these cases was 98 participants, including 77 females and 21 males. The mean age of participants was 20.67 years ($SD= 5.03$), with a range of 18 to 45 years. The breakdown of nationalities provided was as follows: British: 45; Scottish: 43; English: 5; Irish: 4; Northern Irish: 1. Concerning residency, 33 participants stated they were presently residing in the place they answered items with respect to, 64 stated they were not, and 1 did not respond. In terms of total residency, 97 stated they had been resident at some time in their chosen place, and 1 did not respond. The mean length of total residency in chosen hometowns was 16.63 years ($SD=6.56$), ranging from 1 to 45 years.

Materials

The materials used in the study were distributed across two separate questionnaires. Each is discussed in turn below. A copy of the student identity version of Questionnaire 1 is included in Appendix Six to illustrate the nature of items.

Questionnaire 1: Social Identity Prime

This questionnaire had two different formats according to experimental condition. The first was designed to prime the participants' student identity and featured a picture of a group of

students at the top of page one under the title ‘Student Life Survey’. The second was designed to prime their family identity and featured a picture of a family group at the top of page one with the title ‘Family Life Survey’. These features were included to provide a framing effect for each of the social categories involved. A series of measures designed to promote the accessibility of each social identity then followed in forms adapted to each group identity; these are detailed below.

Paragraph Task This measure had an open-ended response format that required participants to think about their assigned social group and their place in it, and then provide a brief description of their group in their own words in a paragraph space provided. This approach has been used alone by other authors (e.g., Haslam et al., 1999) with limited success, but was designed to supplement additional salience manipulations in this study.

Three Things Task This is a 4-item open-ended response measure developed and validated by Haslam et al. (1999). Each item requires the participant to list up to three things that they and most other members of their group do relatively often, three things they do relatively rarely, three things they do well, and three things they do badly. The measure has been identified as ideal when priming two relative identities as almost identical items are used in both conditions (Haslam, 2004), and it has been used successfully to that end in previous studies (e.g. Adarves-Yorno, Postmes, & Haslam, 2006)

Collective Identification This is a five-item measure of global collective identification drawn from four established scales. Two items were drawn from Doosje, Ellemers, and Spears (1995), one from Haslam et al. (1999), one from Hinkle, Taylor, Fox-Cardamone, and Crook (1989), and one from Ellemers, Kortekaas, and Ouwerkerk (1999). Each scale has been validated by the original authors, and includes reliable and easily adaptable items. Each item was chosen according to its suitability for adaptation to the family and student identities used in this study.

Questionnaire 2: Place and People Survey

This questionnaire contained the PIC dependent variables and all potential moderator variables. All items were answered with respect to one specific place type to reduce the variability in place-type responses seen in studies 2 and 3, and because the place identity type needed to be held constant across conditions to allow cross-condition comparisons. The hometown was chosen as the most appropriate place for two reasons: i) this place was the most commonly chosen place in Study 2 and 3; and ii) this place was most commonly associated with the family group in both survey studies and interviews. It was also significantly less transitory than the domestic family home in participants' residential history. Participants were instructed to think about the place they felt was their 'true hometown', to provide the name of that place, and then answer with respect to it. Each of the measures detailed below has already been included in Appendix Four within the Study 2 questionnaire.

Place-related Measures

Place Identity Continuity This is the 20-item scale created to measure individual place identity continuity and broken down into three main subscales. The subscales were: Place Referent Continuity (PRC); Place Future Continuity (PFC); and Place Congruent Continuity (PCC). Each subscale included 10 items, all scored with a 7-point Likert scale format (1: *totally disagree* – 7: *totally agree*). Higher scores on each subscale represented stronger perceptions of place identity continuity.

Place Attachment (PA) This 12-item scale measures the emotional elements of place relationships in terms of attachment to place (Lewicka, 2008). All items were scored with a 7-point Likert scale format (1: *totally disagree* – 7: *totally agree*) and higher scores on the scale represented stronger perceptions of place attachment.

Place Identity (PI) – This is a 10-item measure of place identity strength. Four suitable items were drawn from Williams and Vaske (2003) and some were created specifically for this study on the basis of Study 1 interview transcripts. All items were scored with the same Likert scale format (1: *totally disagree* – 7: *totally agree*) and higher scores on the scale represented stronger perceptions of identification with the chosen place.

Demographic Measures

The final section of the questionnaire included a series of demographic questions. These included specifications of sex, age, and nationality. There was also a series of questions relating to the residential circumstances of participants. These asked whether the participant was resident in the hometown they had chosen and if so for how long, and whether the participant had ever been resident in the hometown they had chosen, and again, if so, for how long.

Procedure

A small pilot study ($N = 21$) was first conducted to ensure that all the variables made sense and to get feedback concerning the effectiveness of the identity primes. All feedback was positive and suggested the measures were comprehensible and effective. Initial results suggested that PIC scores were higher in the family condition, and so the study proper proceeded using the above design. The materials were presented in the form of two questionnaires ostensibly associated with two separate studies: the first a study of family or student life, and the second a study of people and place. All participants attended individual laboratory sessions at the University of Dundee and were randomly assigned to either the family identity prime condition or the student identity prime condition. Each participant completed their assigned version of Questionnaire 1, and then all participants completed the people and place questionnaire containing the dependent variables. All

participants completed ethical procedures before participation, and completed demographic variables after each questionnaire, to maintain the illusion of the studies being unconnected. Participants were all fully debriefed after the experiment, and data were then collated for analysis using the anonymous identifier codes provided by each participant.

Results

Descriptive Statistics

First, all negatively coded items were reversed so that all items on each scale represented stronger endorsement of that variable. Composite variables were then created for use in the analyses. Descriptive statistics for each variable are presented below in Table 8.1 according to experimental condition. Levene's tests for equality of variance did not reach significance therefore independent samples t-tests could be conducted to look for main effects of condition on dependent variables. No significant differences were found across conditions in terms of the place identity continuity variables, place attachment or place identity, despite consistent slightly higher ratings on each variable in the family identity condition. A significant difference was only found in terms of collective identification, with participants rating identification with the family group higher than with student identity ($t(96) = -2.73, p < .01$). However, as the highest average score on this scale is 7, it is clear that levels of identification were high in both the student condition ($M = 6.02; SD = .91$) and the family condition ($M = 6.53; SD = .95$) suggesting that the identity salience manipulations were effective in both conditions. Furthermore, collective identification was not found to moderate the effects of condition on any of the place identity continuity measures and so was not controlled for in subsequent analyses.

Table 8.1 Means and Standard Deviations for all Variables According to Identity Salience Condition

	Student Identity Condition (N=52)		Family Identity Condition (N=46)	
<i>Variables</i>	Mean	SD	Mean	SD
PRC ($\alpha = .88$)	5.93	1.10	6.10	.83
PFC ($\alpha = .85$)	4.69	1.24	4.75	1.39
PCC ($\alpha = .94$)	4.56	1.25	4.60	1.48
PA ($\alpha = .86$)	4.72	.88	4.73	1.02
PI ($\alpha = .92$)	5.09	1.14	5.26	1.12
CI ($\alpha = .91$)	6.02	.91	6.53**	.95

Note: ** $p < .01$; PRC: Place Referent Continuity; PFC: Place Future Continuity; PCC: Place Congruent Continuity; PA: Place Attachment; PI: Place identity; CI: Collective Identification.

Moderated Regression Analyses

Based on the results of studies 2 and 3, it was predicted that place identity strength, attachment to place, and length of residential history are key correlates of perceptions of place identity continuity, therefore the impact of each of these variables on the relationship between social identity salience and place identity continuity measures was examined next. Before regression analyses were conducted, the data within each condition were examined for statistical suitability. Although the relationship between place identity and place attachment was high in both conditions (Student Identity Condition: $r = .83$, $p < .001$; Family Identity Condition: $r = .75$, $p < .001$), there was no evidence of multicollinearity in the variables in either condition as all correlations between variables were below .90, VIF values on all variables were all below 10 and Tolerance values were all above .10 (Field, 2009). Examination of randomly tested standardised residual scatterplots showed relationships between variables to be generally linear with no

evidence of homoscedasticity. A series of moderated regression analyses were therefore conducted using Preacher, Curran, and Bauer's (2006) method of calculating two-way interactions effects in multiple linear regressions.

In each of these analyses place identity continuity measures were initially regressed upon identity salience condition and each of the potential moderating variables, specifically place attachment, place identity, and residential history, in a series of hierarchical multiple linear regressions. Then the impact on variance explained of adding the interaction term between the condition dummy variable and each moderator variable in step 2 was assessed. If the interaction proved to be significant, it was then plotted at -1SD and 1SD of the centred moderator variable, and the significance of the slopes between conditions for high and low levels of the moderator was assessed. This method has been widely used by social identity researchers to explore the impact of social identity salience on key group-based outcomes such as stereotyping and intergroup differentiation (e.g., Jetten, Spears & Manstead, 2001). These analyses revealed that place referent continuity and place congruent continuity ratings were significantly moderated by distinct variables across identity salience conditions. Each of these will be discussed in turn.

Place Referent Continuity, Social Identity Salience and Residential History

Moderated regression analyses indicated that whilst there was no main effect of condition on PRC, the effects varied according to length of residency. Specifically, no significant differences were found between student ($M = 5.95$) and family ($M = 5.62$) identity salience groups if participants were low in residential history in the place selected as their hometown ($t(94) = -1.17$; $p = \text{NS}$). There was, however, a significant difference between groups when residential history was long ($t(94) = 3.27$; $p < .01$), such that when primed with student identity participants were significantly less likely to rate their hometown place identity as being characterised by place

referent continuity ($M = 5.86$). In contrast, when primed with family identity PRC ratings were higher ($M = 6.79$).

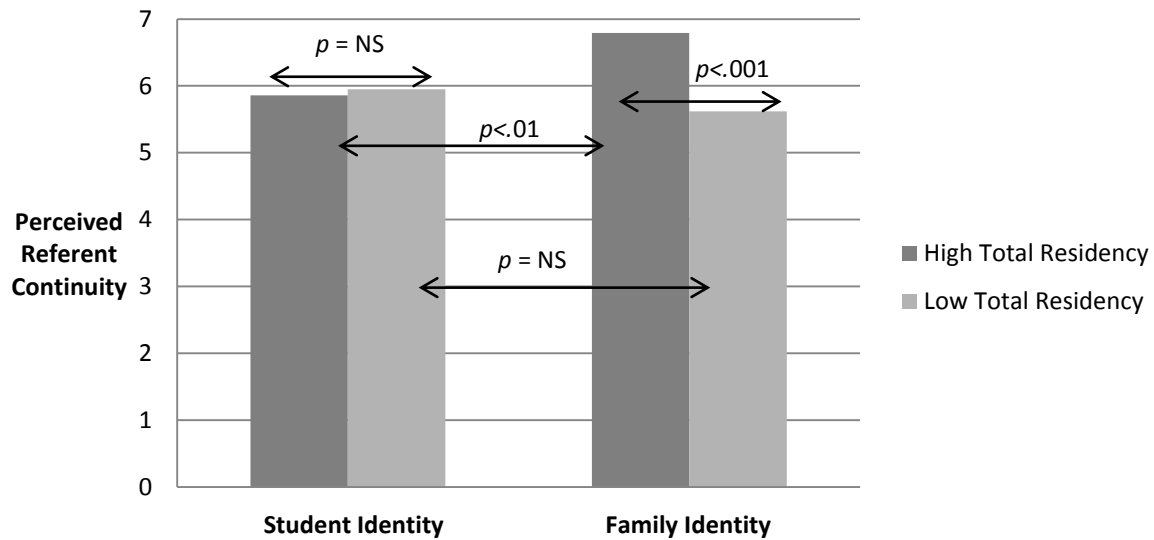

Figure 8.1 Moderated Regression of Identity Salience Condition and Total Years Residency on Place Referent Continuity

Within condition contrasts showed a significant difference between high and low residency participants in the family condition ($t(94) = 3.58; p < .001$), but no differences according to hometown residential history in the student condition ($t(94) = -.32; p = NS$). Each of these relationships is represented above in Figure 8.1¹⁴. None of the other dimensions of place identity continuity were moderated by length of residency.

¹⁴ These results have been presented as bar graphs to allow representation of between and within condition contrasts.

Place Congruent Continuity, Identity Salience and Place Identity

Multiple regression analyses also showed that the effect of identity salience on place congruent continuity was mediated by place identity strength (see Figure 8.2). For those identifying strongly with their home town, family identity salience led to higher ratings of the hometown as identity congruent ($M = 5.52$) than student identity salience ($M = 5.22$), although this trend was not significant ($t(94) = 1.02, p = .13$). However the opposite was true for those whose identification with their selected hometown was low; in this case those in the student identity prime condition ($M = 3.91$) rated the place as more congruent than in the family condition ($M = 3.37$) but again this trend was not significant ($t(94) = -1.68, p = .10$). Within condition contrasts showed that within the student condition ratings of place congruent continuity were significantly higher for participants high in place identification with the chosen hometown ($t(94) = 4.40, p < .001$). Similarly, for those in the family condition participants high in place identity rated PCC significantly higher than those lower in place identification ($t(94) = 6.67; p < .001$).

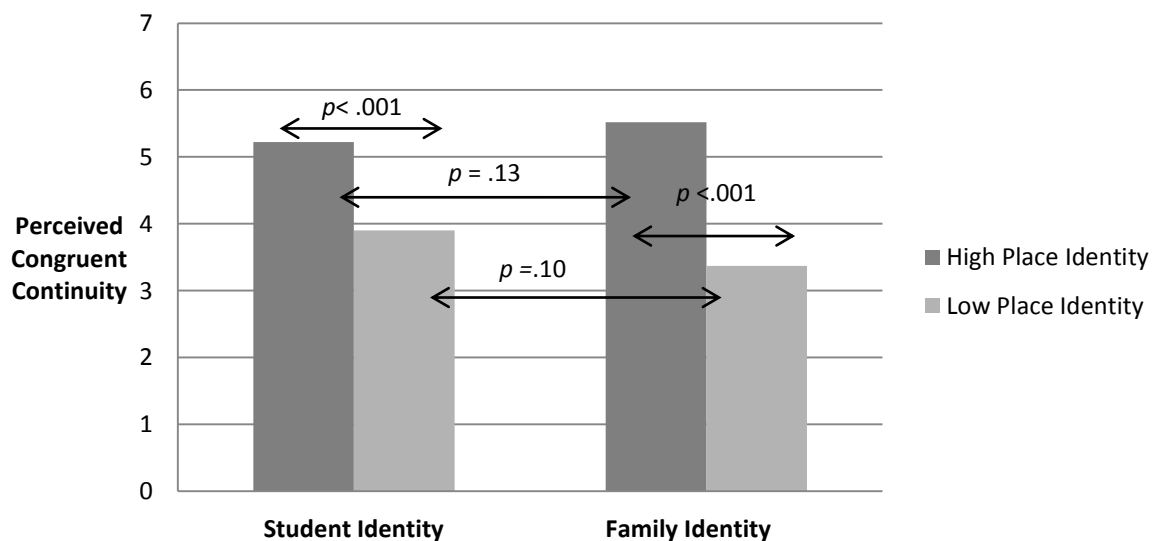

Figure 8.2 Moderated Regression of Identity Salience Condition and Place Identity on Place Congruent Continuity

Place Future Continuity, Social Identity Salience and Place Identity

Two more moderated regressions approached significance. Firstly, there was a near significant moderation of the effects of identity salience on place future continuity by place identity strength. The addition of the interaction term in step two of a hierarchical multiple regression explained a near significant amount of additional variance (R-squared change = .001, $F(1, 94) = 2.74, p = .10$). However, this non-significant interaction meant further across condition explorations of these relationships were not significant. However, within condition contrasts showed greater PFC was reported for those high in place identity in both student ($t(94) = 5.06, p < .001$) and family identity salience conditions ($t(94) = 6.70, p < .001$).

Place Referent Continuity, Social Identity Salience and Place Attachment

Similarly, the moderation of the effects of identity salience on place referent continuity by place attachment also approached significance, with the addition of the interaction term in step two of a hierarchical multiple regression resulting in a near significant change in variance accounted for (R-squared change = .001, $F(1, 94) = 2.57, p = .10$). However, this non-significant interaction meant further across condition explorations of these relationships were not significant. However, within condition contrasts showed greater PRC was reported for those high in place attachment in both student ($t(94) = 4.85, p < .001$) and family identity salience conditions ($t(94) = 3.02, p < .01$).

Discussion

The present study utilised procedural insights from Self-categorisation Theory (Turner et al., 1987) to provide a social psychological explanation for the variability observed in expressions of place identity continuity. This variability in place relationships has been long observed within

environmental psychology, geography, and sociology, where explanations vary from simple differences in levels of place attachment to developmentally ‘atypical’ place relationships (Bah-Fleury, 1996; Giuliani, 2003; Proshansky et al., 1983), and even to ‘nomadic’ identity types (see, Tuan, 1977), and migrant personality types (Freize, et al. 2006)

Within this thesis, the potential significance of identity continuity strategies (Chandler et al., 2003) has also been highlighted as a source of variability, as well as the importance of accounting for patterns of residence and levels of place identification. However, this study represented a unique opportunity to integrate social identity and place identity theories by testing whether variation in place identity continuity might be accounted for by social identity salience – a vital step that goes beyond the existing social identity literature that has involved place as a corollary or feature of social identity (e.g., Levine & Thompson, 2004; Reicher, Hopkins, & Harrison, 2006).

Summary of Findings

The priming of family identity compared with student identity did not reveal any significant differences in student participants’ ratings of referent, congruent, and future place identity continuity in relation to their chosen hometown, despite trends in the predicted direction. However, this lack of main effects is not entirely surprising considering the results of the preceding survey studies exposing the associations between PIC variables and place identity, place attachment, and residential history. As expected, these variables appear to have some moderating role in the impact of social categorisations on perceptions of place identity continuity, but some of these moderating relationships are disappointingly weak and fail to reach significance.

Nevertheless, some important conclusions can be drawn. Firstly, in line with predictions, participants were more likely to rate their hometown as connecting them to their past when categorising themselves in terms of their family group membership – evidenced by higher ratings of place referent continuity – than those categorising themselves in terms of their student identity. Importantly, this was only the case for those who had a longer length of residency in their hometown. For participants with a short length of residence in their chosen hometown, thinking of themselves in terms of their family made no significant difference to PRC ratings, and this was reflected in a significant difference between those high and low in length of residency within the family condition. This is entirely in line with the results of studies 2 and 3 showing the clear, and intuitive, link between accumulated history and place referent continuity. It also reflects the importance of the family group in embodying this historically-directed connection with home, but most importantly it demonstrates that this temporal feature of place identities *is* subject to the effects of social identity manipulations.

A similar pattern was observed between place congruent continuity and social identity type, but this time moderated by strength of place identity. Again, this pattern showed that those higher in the moderating variable rated place identity continuity more strongly when primed with a sense of their family identity in comparison to student identity. This shows that for those who have a strong sense of connection with their hometown, categorising themselves in terms of their family group contributes to an increased sense of congruency between the participant and the place. It is likely therefore, that for those high in identification their hometown identity is deeply entwined with their family identity, meaning that place congruent continuity is highlighted in situations where their family identity is a salient and valid cue for perception and action. However, some of these findings only approached significance and so any interpretations must be made cautiously and with potential non-replication in mind.

Importantly there was also another contrary effect that showed that for those low in place identification with their hometown, place congruent continuity was actually rated *lower* in the family identity condition and higher for those primed with their student identity. One way to interpret this might be to consider the characteristics of those reporting a low sense of place identification with the hometown they selected, and why this might affect the participants' propensity to rate that place with a sense of self-congruency. It might be that those who identified their chosen place as their 'hometown' but then reported a low sense of place identity may have picked their student hometown. This is a possibility because some of the residential histories reported were very low. It makes sense that when categorising as a student then this hometown would provide a sense of congruent continuity, however, when categorising oneself as a family member this place would become significantly less congruent with participants' sense of identity.

Alternatively, these low place identifying students may chose the hometown which is more aligned with their place of origin and family life despite their low identification with it, but the unsuitability of this place may be highlighted even more when they are led to categorise themselves as a family member, the identity that ties them to this unsuitable place. This second interpretation is supported by the significantly lower PCC scores in *both* student and family conditions (around mean and below) for low place identifying participants, suggesting that this hometown is not particularly congruent with either student or family dimensions of self.

Place identity strength also appeared to impact upon place future continuity, such that for those higher in place identification categorising oneself as a family member led to greater perceived future place identity, whereas for those lower in reported place identity student categorisation led to greater projected future in that place. The same interpretations might be drawn here but this moderation was not significant, so again these trends must only be taken as

indicators of effects that might be drawn out with a more effective study design and a larger sample size. Finally, as well as length of residency, place attachment also appeared to have a slight increasing effect on ratings of place referent continuity in the family identity condition. This too was a non-significant moderation but the connection between attachment and length of residency has been found many times before (e.g., Cross, 2001; Giuliani 2003; Rubenstein & Parmelee, 1992), therefore suggesting that this finding might be worth probing in future studies.

Limitations and Potential Future Studies

There are several potential limitations of the study design that may have impacted on the results. Most straightforwardly, it might be that the social identity primes did not successfully lead to self-categorisation in the desired manner. It is possible, for example, that the individual focus of the PIC questions made it difficult to retain a wholly social sense of self-categorisation during the course of the experiment. In their chapter on personality and social identity, Turner, Reynolds, Haslam and Veenstra (2006) have commented on the functional antagonism between personal and social dimensions of self in certain environmental conditions. They suggest that whilst social identity salience will result in changes in self-conceptions such that highlighted social identities will become more likely self-categorisations, there can still be situations where personal and social dimensions of self will both be salient, resulting in complex and potentially oppositional self-conceptions. Keeping this in mind it is possible that the questions, with their focus on personal life narrative and identity continuity, may have interfered with or lessened the effects of the social identity primes. It follows that more significant results may have been achieved if the social PIC measures had been used in the present study. Unfortunately, these were left out in the interests of keeping the second questionnaire brief and because the close correspondence between individual

and social place identity continuity had been consistently observed in the previous two survey studies.

One way to ascertain whether the effectiveness of the primes was an issue would have been to add a more robust manipulation check to provide some assurance that social identity had been successfully manipulated. It would have been ideal to have measures of collective identity corresponding to both family and student identities in both conditions of the experiment. Haslam et al. (1999) use a similar method when priming personal versus national identity. They asked participants to rate the relative importance of each identity following priming, to show higher rates of identification in corresponding conditions. However, using a check of this sort in this study may have risked some undesirable reactivity due to unintended emphasising of the wrong identity type. One alternative may have been some sort of ranking task where participants could provide a list of their important identifications, and the order of listing could be compared across conditions. It is important, however, to note that because a range of validated framing and accessibility-based manipulations were used, and because the levels of collective identification were high in both conditions, it is likely that the social identity manipulations were successful. Moreover, the cross-condition differences observed suggest there was some effect of the primes. Further studies using the social PIC items may help to iron out this issue and detect possible confounds.

The likelihood of the primes being successful means that it is perhaps necessary to look more carefully at the design of the study to explore the reason for the null effects. Further scrutiny of the design suggests that it involves a number of presumptions which prove problematic when interpreting results. Firstly, the design relies upon participants feeling they have a definitive hometown to answer with respect to. Moreover, it presumes they define their hometown as the location they come from, therefore a place which is likely to be connected with their family

identity. However, this might not be the case. Just as not all social identities are considered equally as central or importance to identity (Doosje et al., 1995), it would be problematic to presume all place identities are as relevant and significant as others for each person, and indeed that identification with the hometown will occur at all. It may be that for students who have travelled and changed residency to study at university, the adopted hometown may be a more relevant place identity to answer with respect to. Indeed, as discussed earlier, this tendency to select these places may be reflected in some of the low residential histories in chosen hometowns and the counterintuitive results for low place identifying participants in terms of place congruent continuity. Therefore, although place identity and residential history acted as useful and telling moderator variables in this study, future studies may need to retain more control over the place types employed. One way to isolate a specific identity might be to capitalise on the links between national identity and national territory. For example, by recruiting only Scottish students to answer with respect to Scotland it would be possible to isolate only one particular place from which to explore the antecedents and consequences of place identity continuity, and the conditions within which PIC is expressed.

A second presumption in the study concerns the content of place identities. In this study it was presumed that the family identity would be associated with higher rates of continuity in relation to the hometown place identity, but this might not be the case for many of the individuals in the study. In fact, many families are defined by travel and frequent residential moves (see the accounts of Study 1 interviewees for evidence of this variation) making traditional conceptions of a hometown inappropriate and perhaps less likely to be associated with any sense of identity continuity. In some sense this degree of presumption is inherent in many studies that manipulate identity. For example, in Wilson and Liu's (2003) study challenging personality-based accounts of

social dominance orientation using primes of gender identity, they rely on the stereotypical content of gender identity that is presumed to counter expressions of social dominance.

One way around this problem is to experimentally manipulate the content of the primed identity to look for specific behavioural and perceptual outcomes associated with that imposed definition. This has been done by Byzumic et al. (2008) in their study of closed-mindedness and ideology, where they manipulating the meaning of participants' social identity by presenting the stereotype of young people as open-minded or closed-minded; participants responded by becoming less closed-minded and right-wing in the open-minded condition. Sindic and Reicher (2009) have suggested it is in fact essential in social identity manipulations to appreciate how people understand the content of identities in order to understand the relationships between that identity and behaviour. For example, in their studies they show that for Scottish participants it is not enough to presume that strongly identifying with Scotland leads to less identification with Britain; instead this happens primarily when the content of the British identity is experimentally presented as one that undermines the Scottish.

This manipulation of identity content may be just as equally applied to place identities. For example, if a place identity is seen as involving permanent, binding connections or a lack of opportunity it might be viewed as less desirable, leading to lower levels of place congruent and place future continuity. However, if it is presented as a base to return to or a place full of opportunity, it might become more appealing. Similarly, different versions of place identity may appeal differentially to distinct social groups; an experimental design comparing, for example, younger and older person's identities might be able to provide evidence of this variation and would speak to the issue of when place identity continuity is valuable, or even desired. Future studies would therefore be well-advised to either control for or actively manipulate the content of place

identities to further probe the conditions under which place identity continuity is important and the behavioural consequences of these perceptions in different social contexts. However, the moderating role of levels of place identification found in this study suggest that one challenge that remains is accounting for those participants who do not identify with specific places in a positive sense, despite feeling obliged to label them as 'home' (an reluctant obligation observed during some Study 1 interviews). It may well be that for these individuals a break in continuity is far more desirable, even if the contents of that place identity is experimentally manipulated to appear more desirable or congruent with their self-conceptions.

Conclusions

During Chapter Three it was argued that there are fundamental similarities between conceptualisations of social identity and place identity. It was noted, for example, that like social identities, place identities can be nested, shared, and vary in scale and significance (Cuba & Hummon, 1993; Lalli, 1992). It has also been noted that the limitations of place identity theories might be overcome by the application of methods and insights from other identity theories (Dixon & Durrheim, 2000; Hauge, 2007; Twigger-Ross et al., 2003). This possibility is supported by observations of the above compatibilities between these elements of human identity. The preceding studies included in this thesis have attempted to extend knowledge of this compatibility by showing that just as collectives can be characterised as providing psychologically valuable perceptions of self continuity (Sani et al., 2007; Sani et al., 2008), so can place identities. This study has drawn upon the notion of social context to provide further support for the compatibility of identity processes between these two dimensions of self, and between the theoretical traditions of place identity, identity process, and social identity research.

The addition of this final study was motivated by specific concerns over static, naturalised, and deterministic conceptualisations of place identity, which have been echoed by several other authors (Easthope, 2009; Speller & Twigger-Ross, 2009; Stokowski, 2002). These concerns were responded to in the present study by testing whether perceptions of place identity continuity vary according to self-categorisation to determine whether their significance is context-dependent. It was hoped that in doing so it could be shown that whilst place identity continuity is valuable in some contexts, it might be less relevant in others thus demonstrating the inherently complex but flexible nature of relationships with places in modern western society, at least for those who are afforded choices over place identifications. This work reflects a recent move towards a more in depth, contextualised, and situated notion of interactionism evident in the field of social psychology (Reynolds et al., 2010), and sought to do the same for place identity research.

In their introduction to the *Journal of Environmental Psychology*'s recent special edition on place and identity, Devine-Wright and Clayton (2010) draw comparisons between the well-researched situational variability of ethnic and national identities, and the unexplored variability in place identity. They suggest that longitudinal studies might be one way to access this contextual variability but argue that whatever methods are introduced they must be robust and able to challenge the currently static notions of place identity characteristic of the literature. It is hoped that this study has introduced a path towards capturing the dynamic aspects of self-environment relationships that these authors, and many others, have called for, and that it constitutes an interesting opportunity for future research that can add some theoretical insight to current theories in environmental psychology through the application of social identity methods.

CHAPTER NINE

General Discussion

“For man, geographical reality is first of all the place he is in, the places of his childhood, the environment which summons him to its presence.”

Eric Dardel (1952, p.46)

“There is nothing like returning to a place that remains unchanged to find the ways in which you yourself have altered.”

Nelson Mandela (1994, p. 84)

Introduction

The story of the Tuscan memory painter, Franco Magnani, shared in the prologue of this thesis, told of a man compelling to remain psychologically in touch with the hometown of his youth, despite geographical separation (Sacks, 1995). This thesis has been concerned with exploring this desire for continuity in relationships with significant places – a phenomenon subsequently labelled as *place identity continuity* – and establishing the real significance of this ongoing perceptual connection with places. There is some debate about whether these place relationships are actually characteristic of modern western societies, or whether the need for stable place bonds has been surpassed in modernity (see Giddens, 1991). Accordingly, it is now questioned whether ‘routed identities’ are more appropriate conceptualisations than traditional ‘rooted identities’ (Gustafson, 2001), particularly in a time when maturation and success are often bound up with residential mobility (van Meijl, 2010).

Observations of societal practices such as the hunt for ancestral home lands (Nash, 2003), human territoriality (Grosby, 1995), and the push for heritage preservation (Milligan, 2007), deny the insignificance of places, and disciplines such as human geography and sociology are replete with examples of the bonds between environment, individual, and community (see Chapter Two). Moreover, the psychological literature has provided convincing research evidence supporting the role of places in both individual and collective identity, and the significance of the temporal dimensions of these identity dimensions (see Chapter Three). Therefore drawing upon this literature and research demonstrating the psychological significance of perceived continuity in both personal and social identities (Neisser 1998; Sani, 2008b; Sani, et al., 2008), the overarching research question asked in this thesis was whether the significance of place identities can be accounted for by their ability to provide a sense of identity continuity. This constituted the first primary aim of the research.

In answering this question, this program of research endeavoured to provide a structural analysis of place identity continuity to determine the exact nature of the construct. More specifically, it sought to go beyond the existing literature on place identity continuity by determining whether the construct should involve a future-oriented dimension (place future continuity; PFC), in addition to extant conceptualisations of past-oriented continuity (place referent continuity; PRC) and continuity of fit between person and place (place congruent continuity; PCC) (Twigger-Ross & Uzzell, 1996). This structural analysis constituted the second primary aim of the research.

Lastly, using a social psychological approach, this program of research sought to integrate insights about the relationship between places and identity from Place-Identity Theory (Proshansky, 1978; Proshansky et al., 1983), with the structural and procedural accounts of

Identity Process Theory (Breakwell, 1986, 1992, 1994) and Self-categorisation Theory (Turner, 1985; Turner et al., 1987). In doing so, it attempted to provide a challenge to traditional static and deterministic approaches to place identity by promoting understandings of it as both dynamic and contextually-variable. This integrative approach constituted the final primary aim of the research program.

This final chapter is concerned with summarising and integrating the results of the four empirical studies reported to draw conclusions about the achievements of the research program in light of these aims and the overarching research question¹⁵. A summary of each of the studies and the conclusions of each chapter will therefore follow, before links are drawn between them to formulate an overall assessment of the research program and the understanding of place identity continuity they provide. Any unexpected or inconsistent results will then be discussed before the general limitations of the study designs are considered and assessed. Potential avenues for future research will then be provided before the chapter closes with consideration of the theoretical and practical implications of the findings and final concluding remarks are offered.

Summary of the Findings

In order to promote a deep understanding of the relationships between people and places the research programme began with an interview study, reported in Chapter Five, conducted with individuals living in the Tayside area. The study was concerned with charting individuals' own accounts of their place identifications to determine whether they were characterised by a sense of perceived continuity. This responded to the first thesis aim. The study used a semi-structured

¹⁵ A list of the thesis aims is provided on page 24.

format and data were interpreted using a thematic analysis (Boyatzis, 1998; Braun & Clarke, 2006).

This analysis was done in two parts. The first part involved a deductive approach based upon existing theory to report the significance of place referent continuity (place as a reference point to past identity) and place congruent continuity (place as providing a sense of ongoing congruency with identity) (Twigger-Ross & Uzzell, 1996; Speller et al., 2002), whilst also seeking to identify evidence of place future continuity (place as connecting to future identity). This stage of analysis therefore addressed the second research aim: determining the structure of place identity continuity. The second part involved inductive coding that sought to explore additional features of interviewees' relationships with places relating to place identity continuity. This helped identify the significance of the phenomenon and the contexts within which it was more or less psychologically relevant.

Results from Part 1 indicated that participants' place identities were indeed characterised by a sense of temporal continuity that could link them not only to their past but also to their future, and could provide a sense of congruency derived from a sense of fit between the place and their self-conceptions. These findings provided the first evidence that place identity continuity involved a future-orientated dimension. Each of these dimensions of place identity continuity was also interpreted as involved a number of more detailed sub-themes, described in Chapter Five. This in-depth analysis of each dimension provided an insight into the complexity and richness of meaning associated with perceptions of place identity continuity.

Results from Part 2 revealed three themes within the interview data. Theme one, entitled *The Intertwining of Dimensions*, showed whilst each dimension of place identity continuity could be considered somewhat distinctly, they were also inherently connected in certain ways. For

example, place referent continuity and place congruent continuity often influenced the likelihood of expressions of a projected future in place. Theme two, entitled *The Importance of Place Identification*, revealed that strong place identities are not a feature of all participants' experience. As such, their relationships with places are not characterised by perceived identity continuity. This highlighted the active nature of identification with places that goes beyond simple residential circumstances and satisfaction of needs. Results also indicated that a sense of belonging in place, and the connections between places and relevant social groups, might influence identification and place identity continuity.

Theme three, entitled *The Contextuality of Place Identity Continuity*, showed that whilst place identity continuity perceptions varied across participants they also seemed to vary *within* participants' accounts. This variation appeared to depend upon the salience of particular social identities of the participants. These last two themes both helped respond to the task of identifying the significance of place identity continuity as a feature of place identities (aim 1), and to the bringing together of place identity and social psychological theories (aim 3), because they demonstrated the nuanced relationships between people and places, and the variability between perceptions of place identity continuity: a variability that might be explored using social psychological methods.

Studies 2 and 3, reported in Chapters Six and Seven respectively, saw a shift towards quantitative examination of place relationships and the development of a scale to measure the new construct Place Identity Continuity (PIC). This development involved the construction, evaluation, and refinement of the measure in Study 2, and the cross-validation and confirmation of the scale structure in Study 3. This structural validation provided an opportunity to build on the results of Study 1 by confirming the expected three dimensional structure of the scale, therefore responding

to the second thesis aim. Both studies also quantitatively determined the relationships between each of the PIC dimensions. Both showed that place referent continuity (PRC) and place future continuity (PFC) were slightly related. In contrast, place congruent continuity (PCC) and PFC were closely connected. However, PRC and PCC appeared to be unrelated. This suggested that whilst past relationships with places determine future relationships to some degree, it is more the ability of the place identity to provide a sense of ongoing self-congruency that determines future place identification. Moreover, a past connection with place does not determine a sense of fit between person and place.

Studies 2 and 3 also spoke to the first aim of the thesis - to explore the significance of PIC - by determining the intercorrelations between PIC and other place-related variables. Taken together these studies provided evidence of a positive association between PIC and place attachment, place identity, existential security, and perceptions of the physical continuity of places. Negative relationships between PIC dimensions and personal discontinuity, as well as beliefs about the benefits of residential mobility were also found. Correlation analyses also established the construct validity of the scale. For example, residential history was strongly connected with PRC therefore establishing concurrent validity, and predictive validity was supported by a roughly equal and significant relationship between all PIC dimensions and place identity strength.

In addition to the PIC items these studies also included measures of place identity continuity in relation to place-relevant collective identities. This allowed for the measurement of *social* place identity continuity (SPIC). Intercorrelations between SPIC and each of the included measures were very similar to that of PIC, aside from one key difference: a noticeably stronger relationship between social place referent continuity, and both social place congruent continuity and social place future continuity. This suggests that whilst past place identity continuity does not

necessarily connect with feelings of congruency and projected future in personal terms, the connection between a place and participants' social identities does involve these connections between past and future, and past and congruency.

Study 3 offered a further analysis of the significance of place identity continuity (aim 1), by determining the link between PIC and psychological well-being. It showed that each PIC dimension exerted a unique impact on well-being. PRC appeared to exert a negative effect on well-being, but this effect was suppressed in situations of high place identification. PFC had a positive effect on well-being, and this effect was fully mediated by increased place identification. Finally, PCC exerted a positive effect on well-being, which was not mediated by place identity strength, showing this dimension affected well-being independently. These effects were also largely duplicated for the SPIC measures. The discovery that all of the dimensions of both PIC and SPIC exerted unique impacts on well-being further supported the validity of the three-dimensional approach to its measurement (aim 2).

Both Study 2 and Study 3 also aimed to explore the nature of PIC by examining the effects of identity continuity strategies (Chandler et al., 2003) on it. This was done to begin to address the variability in place identity continuity observed in Study 1 interviews. Study 2 failed to provide evidence for differences in PIC according to continuity construction strategy, which was not wholly unexpected due to the simplicity of the measure in comparison to the existing qualitative measures (Chandler et al., 2003). However, it did show that those in essentialist conditions had less favourable attitudes towards mobility and experienced less personal discontinuity. Therefore, as a follow-up it was re-examined in the general public sample in Study 3. Results there showed that participants selecting an essentialist continuity strategy were higher in perceptions of PCC and reported higher attachment to their chosen place. In contrast, those choosing a narrative continuity

strategy expressed stronger views about the benefits of residential mobility, as found in Study 2. This measure therefore showed some promise in explaining variability in attitudes to places and mobility, place relationships, and place identity continuity. This task, laid out at the end of Study 1, remained to be fully satisfied though, and therefore Study 4 aimed to address it whilst also tackling the third thesis aim: to bring together identity process theory accounts of place and identity, with those of self-categorisation theory and place-identity theory using a social psychological approach.

Study 4, reported in Chapter Eight, was an experimental study exploring the impact of self-categorisation on PIC in relation to the hometown of student participants. It contrasted ratings on PIC, and other place-related variables, across two conditions of social identity salience selected on the basis of Study 1 interviews: the family group identity and the student group identity. Results showed that the impact of self-categorisation on PRC was moderated by length of residential history. However, it was strength of place identity that moderated the effects of self-categorisation on PCC. There appeared to be an effect of self-categorisation on ratings of PFC, also moderated by place identity strength, but this effect did not reach significance. Whilst there was no evidence of main effects and some of the moderated relationships did not reach significance, the key message from Study 4 was that PIC can vary according to self-categorisation.

Integration of the Findings

Taking the results of the studies together, it can be concluded that place identity continuity is a genuine psychological phenomenon representing perceptions of the temporal relationship between people and places. This is supported both by the ability of Study 1 interviewees to discuss these perceptions meaningfully, and by the reliability and validity of the PIC measure in the subsequent questionnaire studies. What is more, it appears PIC is a significant feature of some

place identities associated with place identity strength and the emotional component of that relationship, which can lead to a sense of security and well-being. This has been evidenced in the accounts of interviewees and in the correlational studies that followed.

The structure of PIC has also been confirmed in each of these studies, importantly extending the existing literature to show that PIC does include a sense of future self and demonstrating how important this dimension is in terms of place identity and place attachment. This was achieved by exploring the accounts of interviewees in Study 1 for evidence of the three predicted aspects of place identity continuity. It was then confirmed by the validation of the PIC measure in terms of this three dimensional structure in Studies 2 and 3. However, it should be noted that the interviewee data and the survey data also confirmed the interconnected nature of the PIC dimensions. Taken together these findings suggest that PIC is in line with perceived continuity derived from other aspects of identity such as national groups (Sani et al., 2007; Sani, et al., 2008) in conceptual terms because it involves a perceived connection across time, and not just in a past-oriented manner.

Each of the studies also addressed the need to expand upon the environmental psychological literature by facilitating a study of place identity that recognises its dynamic and contextually-variable nature. This was done initially by drawing upon social psychological theories and methods. Firstly, throughout the thesis the definition of PIC is based upon both the literature on perceived collective continuity (Sani, et al., 2007), and the existing accounts of place identity continuity (PRC and PCC) grounded in the identity process model (Speller et al., 2002; Speller & Twigger-Ross, 2009; Twigger-Ross & Uzzell, 1996). A social identity perspective (Tajfel & Turner, 1986; Turner et al., 1987) was then used to explore the context-specific nature of

PIC, linking together the results from Study 1 and Study 4, and to some degree the observations that PIC and mobility beliefs are correlated.

Unexpected Findings and Limitations

There are three sets of results within the preceding studies that require discussion at this point: i) the lesser importance of place referent continuity for place relationships in comparison with other PIC dimensions in Study 2; ii) the negative impact of place referent continuity on psychological well-being in Study 3; iii) the null effects of social identity salience on place future continuity in Study 4. Each of these will be discussed in turn.

Intercorrelations with Place Referent Continuity

The first set of unexpected results relates to the differential relationships observed between place identity continuity dimensions; most specifically, to the lesser relationships between place referent continuity and place-related variables. Firstly, place referent continuity is reported as uncorrelated with place congruent continuity, and only weakly correlated with place future continuity in both studies 2 and 3. The former of these findings is less surprising, as identifying with a place in the past does not necessarily mean it will be considered fitting in the present. Past connections with place may have been in childhood or earlier adulthood, for example, and therefore dependent on the decisions of family members or needs associated with an earlier life-phase.

Following this reasoning, past places might not be a definite part of the future either, but what is surprising is that this is largely contrary to the literature discussed in Chapters Two and Three. This literature has suggested that connections with place are acquired through the build-up

of experiences, and that this impacts on intentions to maintain connections with places in the future (Cross, 2001; Lowenthal, 1975). The intercorrelations between place referent continuity and measures of place relationships were also surprising. For instance, whilst both PFC and PCC appeared to be reliably linked to place attachment, PRC was only weakly correlated in Study 2 and not significantly correlated in Study 3. Again, this is contrary to a wealth of literature suggesting that this emotional connection with place is built up over time (Cross, 2001; Giuliani 2003; Hay, 1998; McAndrew, 1998; Relph, 1976; Rubenstein & Parmelee, 1992).

One way to approach these findings is to consider the types of place chosen by participants in both of these survey studies. As has been argued in both Chapter Six and Seven discussions, following Korpela (1989), the decision to ask participants to select the places they responded in relation to was made to ensure responses related to places participants *themselves* felt were significant. However, this meant there was little control over the nature of places chosen. In relation to the above findings this means it was impossible to know whether the places chosen were characterised by only short-lived personal connections. In these circumstances it is more likely that having a sense of fit and a sense this place will feature in one's future will determine feelings of attachment. Despite this limitation, it is important to note that these correlational results concerning place attachment, and other place relevant measures, demonstrate the important of future-related conceptualisations of place identity, supporting this addition to the literature.

Place Referent Continuity and Psychological Well-being

A second unexpected finding concerns the negative impact of PRC on well-being, which the mediation analysis in Study 3 (Chapter Seven) showed was suppressed by the positive impact of place identity. This finding was unexpected because it is contrary to predictions made on the basis of the psychological literature suggesting that stable relationships with places have a positive

impact on mental health (Dupuis & Thorn, 1998; Oishi & Schimmack; 2010; Padgett, 2007). The previously discussed limitation related to the issues of place choice has been implicated in Chapter Seven as a possible explanation for this, suggesting that people may have chosen places that they do not have a long history in. However, this lack of PRC would suggest that their well-being would be lower in these cases if there were any relationship between PRC and well-being. This is not the case though, and the direction of effects suggests that increased perceptions of past place identity leads to negative effects on well-being. This suggests that for some people having a long history in their chosen place is not psychologically valuable. Some commentators have noted that long-standing place attachments should not always be presumed as wholly positive (Giuliani, 2003). In fact, many theorists studying the negative impact of place disruption on mental health suggest this effect is mediated by a lack of choice (Bahi-Fleury, 1996) or control (Twigger-Ross & Uzzell, 1996), suggesting there may be situations where a break in continuity is acceptable if it is chosen.

The observed suppression effect of place identity in this case makes theoretical sense. It has been suggested that long-standing place attachments are valuable as they underlie the development of place identity, and therefore valuable self-knowledge (Moser & Uzzell, 2003; Rowles, 1983). Therefore for participants who feel a strong sense of identification with the place they have chosen the negative effects of PRC are cancelled out. A moderated regression design, as opposed to a mediation analysis, may therefore have been more appropriate to explore the effects of PRC on well-being, but the issue of lack of control regarding place choice remains a limitation of the study.

The Effects of Social Identity Salience

The attempt in Study 4 to explore the effects of self-categorisation on PIC responded to the need for convergent theoretical foundations in the study of place identity, by drawing upon social identity methods. The results showed that PIC did vary according to social identity salience, suggesting that perceptions of place relationships might change according to social context. However there was one caveat to these conclusions: the null findings in relation to the PFC dimension. Whilst it appeared that family identity salience might increase PFC for those high in place identity, and decrease it for those low in place identification, these effects were not significant and so no confident conclusions can be drawn from these results. As discussed in Chapter Eight, there is some concern about the nature of the hometown chosen by some participants, but it is possible that the effects only approach significance due to the small sample size involved which is relatively low for a multiple regression analysis (Cohen, Cohen, West & Aiken, 2003).

This study also contained some unexpected results concerning those participants low in the moderating variables. For example, for those low in place identification, PCC was actually lower in the family condition suggesting that when people do not feel identified with their hometown, being reminded of their family identity – potentially associated with the hometown – exacerbates this feeling of incongruence. Whilst these results were not anticipated, when they are integrated with the unexpected results from the previous studies it is apparent that they are completely congruent in their indication that place relationships are exceptionally variable, and using a naturalised, deterministic account may be inappropriate. So, whilst PIC can be a valuable dimension of some place relationships, this is dependent upon many other factors such as suitability, needs, identifications, and social context.

Potential Future Research

Future Studies to Address Limitations

The first series of recommended studies responds to the limitations detailed above and features throughout the discussions of each corresponding study. Firstly, the issue of place choice has been a potential confound in each of the quantitative studies. In Study 2 and Study 3, where participants are asked to respond to their most “significant place”, place choices vary greatly as was the intent of the design. As a consequence, conclusive interpretations were difficult to make. Although, the addition of mediating (Study 3) and moderating (Study 4) variables helped make sense of results in these studies, future studies may benefit from controlling the nature of the place targeted – as was the objective in Study 4. Alternatively, it might be useful to opt for a design that targets only those who express strong place identifications (see Twigger-Ross & Uzzell, 1996). However, this would be done at the expense of being able to explore the nature of PIC dimensions for those who do not identify, and it would leave issues like variability and context-dependence unexplored.

One other suggestion that arises from the limitations of the existing studies – specifically Study 4 – relates to the need to understand the content of place identities, and how they might relate to salient social identifications, before conclusions can be drawn regarding perceptions of identity continuity. Studies manipulating identity content could advance understandings of variations in place relationships by tapping in to the effects of attitudes, values, and normative expectations on place identification, PIC, and place-related behaviours. Moreover, studies such as this would further add to the theoretical integration of place identity and social identity research, as this content-specific analysis already features in the social psychological literature (e.g., Sindic & Reicher, 2009)

Future Studies on Place Identity Continuity

Study 1 was aimed at exploring the temporal aspects of place identity across a broad range of place relationships. This was an essential part of uncovering the nature of the construct within everyday contexts, with all the nuances inherent in those contexts. However, now that the future dimension of PIC has been uncovered, it would be useful to extend these results by determining whether this conceptualisation occurs in more specific populations. It has been suggested, for example, that place attachments become heightened and more apparent in circumstances of loss (Fried, 1963, 2000; Lalli, 1992), and that this loss can have detrimental effects on mental health (Carroll et al., 2009; Fullilove, 2002; Milligan, 2003). Indeed, the literature inspiring this research program has largely focussed its attention on place change and relocation (Speller et al., 2002; Speller & Twigger-Ross, 2009; Twigger-Ross & Uzzell, 1996). However, because these programs have left out a future-oriented dimension of place identity from their analysis, the importance of this dimension – conceivably the *loss* of future identification felt during place disruption – is unexplored in these contexts.

The studies presented in this thesis provide an ideal framework for these future-based analyses. Moreover, application of their methods within these contexts would help test the applicability of the multidimensional structure of the PIC scale in alternative contexts. In particular, it would determine the utility of the measure for identifying the antecedents and consequences of each PIC dimension in contexts of forced relocation. This could apply not only to urban redevelopment, but also to larger scale issues such as international migration and more localised intranational occupational relocation, which is now commonplace in western society.

These sorts of studies could also provide an opportunity to explore the importance of choice in place disruptions. Lack of choice and control over place relationships has been

highlighted as a potential explanation for the detrimental effects of place loss (Bahi-Fleury, 1996; Twigger-Ross & Uzzell, 1996), but these issues remain to be explored. It is conceivable that it is the loss of choice over future place identifications that is central to these processes, especially as a loss of future continuity has been highlighted as potentially problematic both for individuals (Diehl, Jacobs, & Hastings, 2006; Markus & Nurius, 1986; Troll & Skaff, 1997), and groups (Chandler et al., 2003; Wohl et al., 2012). Indeed it appears addressing the issue of choice is becoming more essential when dealing with changing conceptualisations of place identity in current society. Recent studies of place attachment in Poland, for example, have shown that place bonds now cluster around two types: traditional passive types (correlated with age and lower levels of education); and active involved types (correlated with non-territorialism, inclusive European identification, and higher education) (Lewicka, 2011a). It would be very interesting to see how these issues of choice coincide with dimensions of PIC.

Another potential avenue of research stems from the inclusion of the measure to assess identity continuity strategy in Study 2 and 3. This simple measure, developed on the basis of Chandler and colleague's research program looking at the effects of continuity construction on mental health (Chandler et al., 2003), was added as a means of exploring alternative explanations for variability in place relationships. Although it did not provide conclusive results regarding PIC, it did successfully distinguish between people choosing different methods of identity construction on measures relating to place attachment, mobility beliefs, and place congruent continuity, despite its crudeness. This measure is unique to these studies and constitutes the first known attempt at a quantitative measure of identity continuity strategy (although see a recent MSc dissertation by Allen, 2009), replacing the lengthy interview process used in the original studies. With some refinement it may prove a useful extension to the qualitative literature on constructions of identity continuity and their consequences (Chandler & Lalonde, 1998; Chandler et al., 2003; Chandler &

Proulx, 2008), which might be further developed and applied to issues of mobility, identity, and mental health.

Finally, it would be useful to explore the significance of place identity continuity in contexts where issues of place loom large, for example, those that relate to nationality and human conflict. Hopkins and Dixon (2006) have suggested that it is their application to the understanding of these sorts of issues that makes place relationships so worthy of study. As discussed in Chapter Three issues of place identity and attachment are implicit in human territoriality. It is therefore contended that development of a measure of place identity continuity might help promote an understanding of the significance of enduring connections with places, which can incite conflict and lead to the defence of homelands even in the face of adversity. In Miriam Billig's (2006) study with Jewish settlers in the Gaza Strip, she reported that those with strong place attachments were more likely to maintain residency and downplay the risks of remaining there, despite evidence to the contrary. It would be interesting to explore what type of continuity is associated with these emotions: the place simply as congruent with needs and identity, the place as a link to collective past, or the place as part of the projected future. PIC measures, and others included in the present studies, such as existential security, might therefore help elucidate the processes underlying these sorts of residential decisions and help explain the problematic place attachments some researchers have warned against (e.g., Fried, 2000).

Implications

Theoretical Implications

As has been stated earlier, the place identity literature has been critiqued for its lack of procedural accounts and empirical testing; a situation which has left the area characterised by a

variety of disparate measurement instruments and structural claims (Hidalgo & Hernandez, 2001; Lalli, 1992; Manzo, 2003; Pretty, Chipuer, & Bramston, 2003; Twigger-Ross et al., 2003). The main theoretical contribution offered by this research program in terms of place identity has been through the further provision of convergent theoretical foundations already begun by other social psychologists (e.g., Speller et al., 2002). In developing understandings and measurement of place identity continuity it is hoped these studies have explained some of the variation in place relationships, and underlined the need to explore the significance of places as part of identity (Lalli, 1992). Finally, it is hoped that the social identity perspective used has helped address concerns about the limitations of naturalised, essentialist, and fixed notions of place identity (Feldman, 1990; Speller & Twigger-Ross, 2009; Twigger-Ross et al., 2003). This is primarily because they have shown that place identity continuity can vary according to self-categorisation, but also because they have challenged ideas about the primacy of deeply engrained historical relationships with places developed in childhood and enduring throughout adulthood (Proshansky et al., 1983). In this, and by the study of social place identity continuity, these studies have also helped address the individualistic bias in place identity research (Dixon & Durrheim, 2000; Twigger-Ross et al., 2003).

It is hoped that this work has also laid the ground in social psychology for the study of place identity and place identity continuity. This work has not only addressed the context-specificity discussed in Breakwell's (1993) theorising about identity through the use of a self-categorisation approach to place identity, it has also extended the literature on perceived identity continuity. It is now known, for example, that social identities *and* place identities can be characterised by valuable perceptions of identity continuity, which can impact on feelings towards that identity element, emotional and cognitive attachments to it, and psychological well-being (Sani et al., 2007; Sani et al., 2008).

Practical Implications

The relationship between people and places is a pervasive part of the human condition. As such, furthering the understanding of these relationships is a task with several practical implications in addition to those issues discussed in relation to potential future studies. Some of these have been detailed at the end of Chapter Three, but will be reiterated here in the wake of study completion. One particular real-world occurrence that this research informs is processes of mobility. As discussed earlier, Reicher, Hopkins, and Harrison (2006) used (national) category salience to explore processes underlying labour mobility. The present studies have undoubtedly added explanatory power to their conclusions by showing that perceptions of place identity can also be manipulated in this way and that these perceptions are associated with place identity strength and place attachment. The results of Study 2 and 3 showing the connections between PIC and attitudes toward mobility support this contention.

The treatment of PIC as responsive to contextual variation is also a particularly useful addition to the study of mobility as recent sociological accounts have suggested that place identities are better thought of as ‘identifications’ characterised by flexibility, mobility, and flux as opposed to relatively stable inherited ‘identities’ rooted in place (Bauman, 2001). Moreover they have suggested this changeability and active form of identification (cf. Lewicka, 2011a, on place attachment types) is actually better for creating and maintaining a coherent, well-developed sense of self (Easthope, 2009; Fried, 2000). This is reflected in the results of Study 3 connecting place congruent continuity with well-being.

The practical implications of place identity continuity research concerning understanding of place loss and change have been well-documented in preceding sections of this thesis, but it is worth highlighting that these can be applied in quite diverse real-world contexts beyond those

already studied. This includes residential adaptation in contexts such as elderly residential care (see Mitty & Flores, 2008), but also larger scale adaptations such as those that occur in the aftermath of natural disaster (see Carroll et al., 2009). Place referent continuity is clearly challenged in these circumstances, but perceptions of place future continuity may also be implicated in responses to these situations and adaptation to any new environments (see Sampson & Gifford, 2010, on the importance of place-making for refugees in new environmental settings.). Deterministic and essentialist views of place identity that do not involve choice, context, and flexible identity construction, are not as able to account for coping in these situations (Sampson & Gifford, 2010). The social psychological approach in this series of studies is therefore valuable for understanding these sorts of experiences.

Concluding Remarks

This research program has allowed the drawing of several key conclusions. Firstly, the research suggests place identity continuity is a key feature of place identity. It is significant because it is associated with stronger identification, increased attachment, and well-being. Secondly, place identity continuity is not only characterised by past place identification and continuing perceptions of congruency between place and person, but also with future place identification. Moreover, it is the latter two dimensions that are more connected with place attachment bonds and mental health. Thirdly, place identity can be likened to other aspects of identity in several ways; one of these is its variation according to social context. This variation in place relationships is cited as a key feature of modern society. So much so that some commentators have claimed that place identity is fundamentally changing (see Giddens, 1991; Lewicka, 2011a). This research does not deny these changes. Indeed issues of choice, fit, and consideration of the future are ubiquitous in the findings. However, the research has shown that

for many deep and enduring bonds with places exist and that these may influence perceptions, emotions, and potentially behaviours. Perhaps the view of Gertrude Stein, American writer and poet, and student of William James, is an apt description of the need for continuity as it exists in modern western society. She asks, “What good are roots if you can’t take them with you?”

Places, it seems, do link us to our past, but they also give us a continuing sense of who we are, and importantly, of where we are going.

REFERENCES

- Abell, J., Condor, S., & Stevenson, C. (2006). "We are an island": Geographical imagery in accounts of citizenship, civil society, and national identity in Scotland and in England. *Political Psychology, 27*, 191–210.
- Adarves-Yorno, I., Postmes, T., & Haslam, S. A. (2006). Social identity and the recognition of creativity in groups. *British Journal of Social Psychology, 45*, 479-497.
- Agnew, J. A. (1987). *Place and politics: The geographical mediation of state and society*. Boston: Allen & Unwin.
- Ahmed, S., Castañeda, C., Fortier, A., & Sheller, M. (2003). Introduction: Uprootings/regroundings: Questions of home and migration. In S. Ahmed, C. Castañeda, A. Fortier & M. Sheller (Eds). *Uprootings/Regroundings: Questions of home and migration* (pp 1-19). Oxford: Berg.
- Akaike, H. (1987). Factor-analysis and AIC. *Psychometrika, 52*, 317-332.
- Akintola, O. (2011). What motivates people to volunteer? The case of volunteer AIDS caregivers in faith-based organizations in KwaZulu-Natal, *Health Policy and Planning, 26*, 53–62.
- Allen J.W. (2009). *Assessing variability in reasoning about self-continuity: the development and testing of a Likert-scaled measure*. (MSc Dissertation). University of Victoria, Victoria, BC. Available at: <http://dspace.library.uvic.ca:8080/handle/1828/1796>
- Allen, S. (2008). Finding home: Challenges faced by geographically mobile families. *Family Relations, 57*, 84-99.
- Allport, G. W. (1943). The ego in contemporary psychology. *Psychological Review, 50*, 451-478.
- Altman, I., & Low, S. M. (1992). *Place attachment*. New York: Plenum Press.
- Ansari, H. (2007). Burying the dead: Making Muslim space in Britain. *Historical Research, 80*, 545-566.

- Antaki, C., Billig, M.G., Edwards, D. & Potter, J.A., (2003). Discourse analysis means doing analysis: A critique of six analytic shortcomings. *Discourse Analysis Online, 1*. Available at: <http://www.shu.ac.uk/daol/articles/v1/n1/a1/antaki2002002-paper.html>
- Arbuckle, J.L. (2008). *Amos 17.0 user's guide*. Chicago, IL: SPSS Inc.
- Armbrecht, A. (2008). *Thin places: A pilgrimage home*. New York: Columbia University Press.
- Auburn, T., & Barnes, R. (2006). Producing place: A neo-Schutzian perspective on the 'psychology of place'. *Journal of Environmental Psychology, 26*, 38-50.
- Baars, B. (1997). *In the theatre of consciousness: The workspace of the mind*. Oxford: Oxford University Press.
- Babbie, E., Mouton, J., Vorster, P., & Prozesky, B. (1998). *The practice of social research*. Oxford: Oxford University Press.
- Bahi-Fleury, G. (1996). *Histoire, identité résidentielle et attachement au quartier actuel*. [History, place identity, and attachment to the present neighbourhood] (PhD. dissertation). Paris: Université René Descartes.
- Bal, E., & Sinha-Kerkhoff, K. (2008). Religious identity, territory, and partition: India and its Muslim diaspora in Surinam and the Netherlands. *Nationalism and Ethnic Politics, 14*, 155 - 188.
- Balzer, T. (2007). *Thin places: An evangelical journey into Celtic Christianity*. Siloam Springs, AR: Leafwood Publishers.
- Banaji, M. R., & Prentice, D. A. (1994). The self in social contexts. *Annual Review of Psychology, 45*, 297-332.
- Barnes, R.K, Auburn, T. & Lea, S. (1998) Policing new travellers: The role of space in stories of conflict. In R. Forrester & C. Percy (Eds.), *Proceedings of the International Conference on Discourse and the Social Order* (pp. 211-221). Aston Business School, Birmingham: Aston University.
- Barnes, R., Auburn, T., & Lea, S. (2004). Citizenship in practice. *British Journal of Social Psychology, 43*, 187–206.

- Baron, R. M., & Kenny, D. A. (1986). The moderator-mediator variable distinction in social psychological research: Conceptual, strategic, and statistical considerations. *Journal of Personality and Social Psychology*, *51*, 1173-1182.
- Barrett, P. (2007). Structural equation modelling: Adjudging model fit. *Personality and Individual Differences*, *42*, 815-24.
- Basu, P. (2005). Macpherson country: genealogical identities, spatial histories and the Scottish diasporic clanscape. *Cultural Geographies*, *12*, 123-150.
- Basu, P. (2007). *Highland homecomings: Genealogy and heritage-tourism in the Scottish diaspora*. London: Routledge.
- Bauman, Z. (2001). *The individualised society*. Cambridge: Polity Press.
- Baumeister, R. F. (1998). The self. In D. T. Gilbert, S. T. Fiske, & G. Lindzey (Eds.), *Handbook of social psychology* (4th ed., pp. 680-740). New York: McGraw-Hill.
- Baumeister, R. F. (2000). *Self in social psychology: Key readings in social psychology*. Philadelphia, PA: Psychology Press.
- Baumeister, R. F., & Leary, M. R. (1995). The need to belong: Desire for interpersonal attachments as a fundamental human motivation. *Psychological Bulletin*, *117*, 497-529.
- Bentler, P. M. (1980). Multivariate analysis with latent variables causal modeling. *Annual Review of Psychology*, *31*, 419-456.
- Bentler, P. M. (2007). On tests and indices for evaluating structural models. *Personality and Individual Differences*, *42*, 825-829.
- Bentler, P. M., & Bonett, D. G. (1980). Significance tests and goodness of fit in the analysis of covariance-structures. *Psychological Bulletin*, *88*, 588-606.
- Bernardo, F., & Palma, J. M. (2005). Place change and identity processes. *Medio Ambiente y Comportamiento humano*, *6*, 71-87. Translation available at: <http://hdl.handle.net/10174/4675>

- Billig, M. (2006). Is my home my castle? Place attachment, risk perception, and religious faith. *Environment and Behavior*, 38, 248-265.
- Bird, A. & Reese, E. (2008). Autobiographical memory in childhood and the development of a continuous self. In F. Sani (Ed.), *Self continuity: Individual and collective perspectives* (pp. 43-54). Hove: Psychology Press.
- Bethell, V. (2003). *Hiraeth*. A digital story from Capture Wales. Dyffryn Ardudwy: BBC Wales.
Available at:
http://www.bbc.co.uk/wales/audiovideo/sites/yourvideo/pages/val_bethell_01.shtml
- Blackburn, S. (1996). *The Oxford dictionary of philosophy*. Oxford: Oxford University Press.
- Bluck, S., & Alea, N. (2008). Remembering being me: The self continuity function of autobiographical memory in younger and older adults. In F. Sani (Ed.), *Self continuity: Individual and collective perspectives*. Hove: Psychology Press.
- Bluck, S., & Habermas, T. (2001). Extending the study of autobiographical memory: Thinking back about life across the life span. *Review of General Psychology*, 5, 135-147.
- Blunch, N.J., (2008). *Introduction to structural equation modelling using SPSS and AMOS*. London: Sage.
- Bollen, K. A. (1989). *Structural equations with latent variables*. New York: John Wiley.
- Bonaiuto, M., Breakwell, G. M., & Cano, I. (1996). Identity processes and environmental threat: The effects of nationalism and local identity upon perception of beach pollution. *Journal of Community & Applied Social Psychology*, 6, 157-175.
- Bonnes, M., Lee, T., & Bonaiuto, M. (2003). Theory and practice in environmental psychology: An introduction. In M. Bonnes, T. Lee, & M. Bonaiuto (Eds.). *Psychological theories for environmental issues* (pp. 1-26). Wiltshire, UK: Antony Rowe Ltd.
- Bonnes, M. & Secchiaroli, G. (1995). *Environmental psychology: A psycho-social introduction*. London: Sage.
- Bowe, M. (2008). *Perceived family continuity, well-being, and family functioning* (MSc dissertation), Department of Psychology, University of Dundee, Dundee.

- Bowlby, J. (1969). *Attachment and loss, Vol. 1: Attachment*. New York: Basic Books.
- Boyatzis, R. (1998). *Transforming qualitative information: Thematic analysis and code development*. Thousand Oaks: Sage.
- Brandtstader, J., & Greve, W. (1994). The aging self: Stabilizing and protective processes. *Developmental Review, 14*, 52-80.
- Branscombe, N. R., Doosje, B. J., & McGarty, C. (2002). Collective guilt: Antecedents, correlates and consequences. In D. M. Mackie & E. R. Smith (Eds.). *From prejudice to intergroup relations: Differentiated reactions to social groups* (pp. 49–66). New York: Psychology Press.
- Braun, V., & Clarke, V. (2006). Using thematic analysis in psychology. *Qualitative Research in Psychology, 3*, 77-101.
- Breakwell, G. (1986). *Coping with threatened identities*. London: Methuen & Co.
- Breakwell, G.M. (1987). Identity. In H. Beloff & A. Coleman (Eds.), *Psychological survey* (pp.43-66). London: Methuen
- Breakwell, G. M. (1992). Processes of self-evaluation: Efficacy and estrangement. In G. M. Breakwell (Ed.), *Social psychology of identity and self-concept* (pp. 35-55). London: Surrey University Press.
- Breakwell, G. M. (1993a). Integrating paradigms: methodological implications. In G. M. Breakwell & D. V. Canter, (Eds.), *Empirical approaches to social representations* (pp. 180-201). Oxford: Clarendon Press.
- Breakwell, G.M. (1993b). Social representations and social identity. *Papers on Social Representations 2*, 1-21.
- Breakwell, G. M. (1994). *Identity process theory*. Paper presented at the Joint Colloquium, University of Quebec, Montreal/University of Montreal, Montreal.
- Breakwell, G. M. (1996). *The identity of places and place identity*. Paper presented at the Conference on Representations of the Landscape, Torino, Italy.

- Brewer, J., & Hunter, A. (1989). *Multimethod research: A synthesis of styles*. Newbury Park, CA: Sage
- Brown, S. D., & Reavey, P. (2008). Vicarious and post-memory practices in adopting families: The re-production of the past through photography and narrative. *Journal of Community & Applied Social Psychology*, 18, 474-491.
- Brown, R. J. (1986). Social identity and the environment: A commentary. In D. Canter, J. C. Jesuino, L. Soczka & G. M. Stephenson (Eds.), *Environmental social psychology* (pp. 219-221). Dordrecht: Kluwer.
- Brown, T. A. (2006). *Confirmatory factor analysis for applied research*. New York: Guilford Press.
- Brown, M. W., & Cudeck, R. (1993). Alternative ways of assessing model fit. In K.A. Bollen, & J. S. Long (Eds.), *Testing structural equation models* (pp. 136–162). Newbury Park: Sage.
- Brown, B. B., & Perkins, D. D. (1992). Disruptions in place attachment. In I. Altman & S. Low (Eds.), *Place attachment* (pp. 279–304). New York: Plenum.
- Burris, C. T., & Rempel, J. K. (2004). "It's the end of the world as we know it": Threat and the spatial-symbolic self. *Journal of Personality and Social Psychology*, 86, 19-42.
- Burris, C. T., & Rempel, J. K. (2008). Spanning Time: An Amoebic Self Perspective. In F. Sani (Ed.), *Self continuity: Individual and collective perspectives* (pp. 101-113). New York: Psychology Press.
- Byrne, B. (2004). Qualitative interviewing. In C. Seale, (Ed.) *Researching society and culture* (pp. 179-192). London: Sage.
- Byrne, B. (2009). *Structural equation modelling with AMOS: Basic concepts, applications, and programming*. London: Routledge.
- Bizumic, B., Turner, J. C., Reynolds, K., & Kajtar, B. (2008). *Closed-mindedness, ideology and prejudice: A self-categorization perspective*. Paper presented at the Fifteenth General Meeting of the European Association of Experimental Social Psychology, Opatija, Croatia.
- Canter, D. (1977). *The psychology of place*. London: The Architectural Press.

- Campbell, J. D. (1990). Self-esteem and the clarity of the self-concept. *Journal of Personality and Social Psychology*, 59, 538-549.
- Campbell, J. D., & Lavalee, L. F. (1993). Who am I? The role of self-concept confusion in understanding the behavior of people with low self-esteem. In R. F. Baumeister (Ed.), *Selfesteem: The puzzle of low self-regard* (pp. 3–20). New York: Plenum Press.
- Campbell, J. D., Trapnell, P. D., Heine, S. J., Katz, I. M., Lavallee, L. F., & Lehman, D. R. (1996). Self-concept clarity: Measurement, personality correlates, and cultural boundaries. *Journal of Personality and Social Psychology*, 70, 141-156.
- Camus, A. (1955). *The myth of Sisyphus*. New York: Vintage Book.
- Carroll, B., Morbey, H., Balogh, R., & Araoz, G. (2009). Flooded homes, broken bonds, the meaning of home, psychological processes and their impact on psychological health in a disaster. *Health & Place*, 15, 540-547.
- Casey, E.S. (1997). *The fate of place: A philosophical history*. Berkeley: University of California Press.
- Casey, E. (2001). Body, self and landscape: A geophilosophical inquiry into the place-world. In P. Adams, S. Hoelscher, & K. Till (Eds.) *Textures of place: exploring humanist geographies* (pp. 403-425). Minneapolis, MN: University of Minnesota Press.
- Chandler, M. J. & Lalonde, C. E. (2008). Cultural continuity as a protective factor against suicide in First Nations youth horizons. *A special issue on Aboriginal youth, hope or heartbreak: Aboriginal youth and Canada's future*. 10, 68-72.
- Chandler, M. J., & Lalonde, C. E. (1998). Cultural continuity as a hedge against suicide in Canada's First Nations. *Transcultural Psychiatry*, 35, 191-219.
- Chandler, M. J., Lalonde, C. E., Sokol, B. W., & Hallett, D. (2003). Personal persistence, identity development, and suicide: A study of Native and non-Native North American adolescents. *Monographs of the Society for Research in Child Development*, 68 (2, Serial No. 273).

- Chandler, M. J., & Proulx, T. (2008). Personal persistence and persistent peoples: Continuities in the lives of individual and whole cultural communities. In F. Sani (Ed.), *Self continuity: Individual and collective perspectives* (pp. 213-226). Hove: Psychology Press.
- Chawla, L. (1992). Childhood place attachments. In I. Altman & S. M. Low (Eds.), *Place Attachment* (pp. 63-86). New York: Plenum Press.
- Chow, K., & Healey, M. (2008). Place attachment and place identity: First-year undergraduates making the transition from home to university. *Journal of Environmental Psychology, 28*, 362-372.
- Cobb, E. (1970). The ecology of imagination in childhood. In P. Shepard & D. McKinley (Eds.), *The subversive science* (pp. 122-132). Boston: Houghton Mifflin.
- Cohen, J., Cohen, P., West, S.G., & Aiken, L.S. (2003). *Applied multiple regression/correlation analysis for the behavioral sciences* (3rd ed.), Mahwah, NJ: Lawrence Erlbaum Associates.
- Coles, R. (1972). Migrants, sharecroppers, mountaineers. *Children of crisis* (Vol. II). Boston: Little, Brown and Company.
- Condor, S. (1996). Social identity and time. In W. P. Robinson (Ed.), *Social groups and identities: Developing the legacy of Henri Tajfel* (pp. 285-315). Oxford: Butterworth Heinmann.
- Conway, M. A., & Hague, S. (1999). Overshadowing the reminiscence bump: Memories of a struggle for independence. *Journal of Adult Development, 6*, 35-44.
- Conway, M. A., Singer, J. A., & Tagini, A. (2004). The self and autobiographical memory: Correspondence and coherence. *Social Cognition, 22*, 491-529.
- Crabtree, B.F. & Miller, W.L. (1999) Using codes and code manuals: A template organizing style of interpretation. In Crabtree, B.F. & Miller, W.L. (Eds.) *Doing qualitative research* (2nd ed., pp. 163-178). Thousand Oaks: Sage Publications.
- Craik, K. H., & McKechnie, G. E. (1977). Personality and the environment. *Environment and Behavior, 9*, 155-168.

- Cross, J.E. (2001). *What is sense of place?* Paper presented at the Archives of the Twelfth Headwaters Conference. Available at:
http://www.western.edu/headwaters/archivesheadwaters12_papers/cross_paper.html
- Creswell, J. W. (2003). *Research design: Quantitative, qualitative, and mixed methods approaches*. Thousand Oaks: Sage Publications.
- Cuba, L., & Hummon, D. M. (1993). A place to call home: Identification with dwelling, community, and region. *The Sociological Quarterly*, 34, 111-131.
- Cudeck, R., & Brown, M.W. (1983). Cross-validation of covariance structures. *Multivariate Behavioural Research*, 18, 147-167.
- Danziger, K. (1985). The methodological imperative in psychology. *Philosophy of the Social Sciences*, 15, 1-13.
- Dardel, E. (1952). *L'Homme et la Terre: Nature de réalité géographique*. Paris: Presses universitaires de France.
- D'Argembeau, A., Raffard, S., & Van der Linden, M. (2008). Remembering the past and imagining the future in schizophrenia. *Journal of Abnormal Psychology*, 117, 247-251.
- DeCuir-Gunby, J.T., Marshall, P.L., & McCulloch, A.W. (2011). Developing and using a codebook for the analysis of interview data: An example from a professional development research project. *Field Methods*, 23, 136-155.
- Dennett, D.C., (1991). *Consciousness explained*. London: Penguin Books.
- Denzin, N.K., (1989). *Interpretive biography*. Illinois: Sage
- Descartes, R. (1641/1993). *Meditations on first philosophy*. (Translated by D. A. Cress, 3rd ed.) Indianapolis, IN: Hackett Publishing Company.
- De Young, R. (1999). Environmental psychology. In D. E. Alexander & R. W. Fairbridge (Eds.), *Encyclopedia of environmental science* (pp. 223-224). Hingham, MA: Kluwer Academic Publishers.

- Devine-Wright, P., & Clayton, S. (2010) Introduction to the special issue: Place, identity and environmental behaviour. *Journal of Environmental Psychology, 30*, 267-270.
- Devine-Wright, P., & Lyons, E. (1997). Remembering pasts and representing places: The construction of national identities in Ireland. *Journal of Environmental Psychology, 17*, 33-45.
- Diehl, M., Jacobs, L., & Hastings, C. (2006). Temporal stability and authenticity of self-representations in adulthood. *Journal of Adult Development, 13*, 10-22.
- Diener, E., Emmons, R. A., Larsen, R. J., & Griffin, S. (1985). The satisfaction with life scale. *Journal of Personality Assessment, 49*, 71-75.
- Dixon, J. (2001). Contact and boundaries: 'Locating' the social psychology of intergroup relations. *Theory & Psychology, 11*, 587-608.
- Dixon, J., & Durrheim, K. (2000). Displacing place-identity: A discursive approach to locating self and other. *British Journal of Social Psychology, 39*, 27-44.
- Dixon, J., & Durrheim, K. (2004). Dislocating identity: Desegregation and the transformation of place. *Journal of Environmental Psychology, 24*, 455-473.
- Dixon, J., Foster, D. H., Durrheim, K., & Wilbraham, L. (1994). Discourse and the politics of space in South Africa: The squatter crisis. *Discourse & Society, 5*, 277-296.
- Dixon, J., Levine, M., & McAuley, R. (2006). Locating impropriety: Street drinking, moral order, and the ideological dilemma of public space. *Political Psychology, 27*, 171-190.
- Dixon, J., Reicher, S., & Foster, D. H. (1997). Ideology, geography and racial exclusion: The squatter camp as 'blot on the landscape'. *Text, 17*, 317-348.
- Doosje, B., Ellemers, N., & Spears, R. (1995). Perceived intragroup variability as a function of group status and identification. *Journal of Experimental Social Psychology, 31*, 410-436.
- Dovey, K. (1985). Home and homelessness. In I. Altman & C.M. Werner (Eds.) *Home environments* (pp. 33-61). New York, NY: Plenum Press.

- Droseltis, O. & Vignoles, V.L. (2010). Towards an integrative model of place identification: Dimensionality and predictors of intrapersonal-level place preferences. *Journal of Environmental Psychology, 30*, 23–34.
- Dupuis, A., & Thorns, D. C. (1998). Home, home ownership, and the search for ontological security. *The Sociological Review, 46*, 24-47.
- Easthope, H. (2009). Fixed identities in a mobile world? The relationship between mobility, place, and identity. *Identities: Global Studies in Culture and Power, 16*, 61-82.
- Edelman, G.M. (1992). *Bright air, brilliant fire: On the matter of the mind*. Harmondsworth: Penguin Books.
- Ellemers, N., Kortekaas, P., & Ouwerkerk, J. W. (1999). Self-categorisation, commitment to the group and group self-esteem as related but distinct aspects of social identity. *European Journal of Social Psychology, 29*, 371-389.
- Erikson, E. H. (1959). Identity and the life cycle. *Psychological Issues, 1*, 18-164.
- Feldman, R. M. (1990). Settlement-identity: Psychological bonds with home places in a mobile society. *Environment and Behavior, 22*, 183-229.
- Feldman, R. M. (1996). Constancy and change in attachments to types of settlements. *Environment and Behavior, 28*, 419-445.
- Fereday, J., & Muir-Cochrane, E. (2006). Demonstrating rigor using thematic analysis: A hybrid approach of inductive and deductive coding and theme development. *International Journal of Qualitative Methods, 5*, 80-92.
- Field, A. (2009). *Discovering statistics using SPSS*. London: Sage.
- Fife-Schaw, C. (2000). Introduction to structural equation modeling. In G.M. Breakwell, S. Hammond & C. Fife-Schaw (Eds.), *Research methods in psychology* (2nd ed., pp. 397-413). London: Sage.
- Fivush, R., Habermas, T, Waters, T. E. A., & Zaman, W. (2011). The making of autobiographical memory: Intersections of culture, narratives and identity. *International Journal of Psychology, 46*, 321-345.

- Fivush, R., Bohanek, J. G., & Duke, M. (2008). The intergenerational self: Subjective perspective and family history. In F. Sani (Ed.), *Self continuity: Individual and collective perspectives* (pp. 131-143). Hove: Psychology Press.
- Fox, D & Prilleltensky, I. (1997). Introducing critical psychology: Values, assumptions and the status quo. In Fox, D. & Prilleltensky, I. (Eds.). *Critical psychology: An introduction* (pp. 3-20). London: Sage.
- Frie, R. (2011). Identity, narrative, and lived experience after postmodernity: Between multiplicity and continuity. *Journal of Phenomenological Psychology, 42*, 46–60.
- Frieze, I. H., Hansen, S. B., & Boneva, B. (2006). The migrant personality and college students' plans for geographic mobility. *Journal of Environmental Psychology, 26*, 170-177.
- Fried, M. (1963). Grieving for a lost home. In L. Duhl (Ed.), *The urban condition* (pp. 151-171). New York: Basic Books.
- Fried, M. (2000). Continuities and discontinuities of place. *Journal of Environmental Psychology, 20*, 193-205.
- Fullilove, M. (1996). Psychiatric implications of displacement: contributions from the psychology of place. *American Journal of Psychiatry, 153*, 1516-1523.
- Fullilove, M. (2001). Root shock: The consequences of African American dispossession. *Journal of Urban Health, 78*, 72-80.
- Fullilove, M. (2002). *The house of Joshua: Meditations on family and place*. Lincoln, NE: University of Nebraska Press.
- Garson, G.D. (2012). *Structural Equation Modeling*. Ashboro: Statistical Associates Publishers.
- Germann Molz, J. (2008). Global abode: Home and mobility in narratives of round-the-world travel. *Space and Culture, 11*, 325-342.
- Gerson, K. Stueve, C.A., & Fischer, C.S. (1977). Attachment to place. In C.S. Fischer, R.M., Jackson, C.A. Stueve, K. Gerson, L. Jones, & M. Baldassare (Eds.) *Networks and Places* (pp. 139-161). New York: The Free Press.

- Giddens, A. (1991). *Modernity and self-identity: Self and society in the late modern age*. Cambridge: Polity.
- Gieryn, T. (2000). A space for place in sociology. *Annual Review of Sociology*, 26, 463–496.
- Giuliani, M. V. (2003). Theory of attachment and place attachment. In M. Bonnes, T. Lee & M. Bonaiuto (Eds.), *Psychological theories for environmental issues*. (pp. 137-170). Aldershot: Ashgate Publishing Ltd.
- Gosling, S. D., Rentfrow, P. J., & Swann, W. B. Jr. (2003). A very brief measure of the big-five personality domains. *Journal of Research in Personality*, 37, 504-528.
- Graumann, C. G. (1983). On multiple identities. *International Social Sciences Journal*, 35, 309-329.
- Gupta, A., & Ferguson, J. (1997). Culture, power, place: Ethnography at the end of an era. In A. Gupta & J. Ferguson (Eds.). *Culture, power, place: Explorations in critical anthropology* (pp. 1-32). Durham, NC: Duke University Press.
- Gustafson, P. (2001). Meanings of place: everyday experience and theoretical conceptualizations. *Journal of Environmental Psychology*, 21, 5-16.
- Haberman, B. (1999). Continuity challenges of Parkinson's disease in middle life. *Journal of Neuroscience Nursing*, 31, 200-207.
- Hammersley, M. (1996). The relationship between qualitative and quantitative research: Paradigm loyalty versus methodological eclecticism. In J.T.E. Richardson (Ed.), *Handbook of research in psychology and the social sciences* (pp. 89-107). Leicester, UK: BPS Books
- Hartig, T., Mang, M., & Evans, G. W. (1991). Restorative effects of natural environment Experiences. *Environment and Behavior*, 23, 3-26.
- Haslam, S. A. (2004). *Psychology in organizations* (2nd ed.). London: Sage.
- Haslam, C., Jetten, J., Haslam, S. A., Pugliese, C. E., & Tonks, J. (2011). I remember therefore I am, and I am therefore I remember: Exploring the contributions of episodic and semantic self-knowledge to strength of identity. *British Journal of Psychology*, 102, 184-203.

- Haslam S. A., Oakes, P.J., Reynolds, K.J., & Turner, J.C. (1999). Social identity salience and the emergence of stereotype consensus. *Personality and Social Psychology Bulletin*, 25, 809-818.
- Haslam, A. & McGarty, C. (2010). *Research methods and statistics in psychology*. London: Sage.
- Hauge, A. L. (2007). Identity and place: A critical comparison of three identity theories. *Architectural Science Review*, 50, 44-51.
- Hawke, S. K. (2011). Local residents exploring heritage in the North Pennines of England: Sense of place and social sustainability. *International Journal of Heritage and Sustainable Development*, 1, 32-40.
- Hay, R.B. (1990). *Sense of place: Cross-cultural perspectives from Banks Peninsula*. (PhD. dissertation) Department of Geography, University of Canterbury, Christchurch.
- Hay, R.B. (1998a). A rooted sense of place in cross-cultural perspective. *Canadian Geographer*, 42, 245-266.
- Hay, R.B. (1998b). Sense of place in a developmental context. *Journal of Environmental Psychology*, 18, 5-29.
- Hayden, D. (1997). Urban landscape history: the sense of place and the politics of space. In P. Groth, & T. Bressi (Eds.), *Understanding ordinary landscapes* (pp. 111–133). New Haven: Yale University Press.
- Hayes, N. (1997) Theory-led thematic analysis: Social identification in small companies. In N. Hayes (Ed.). *Doing qualitative analysis in psychology* (pp. 93-114). Hove: Psychology Press.
- Hayes, A.F. (2009). Beyond Baron and Kenny: Statistical mediation analysis in the new millennium. *Communication Monographs*, 76, 408-420.
- Heidegger, M. (1971). *Poetry, language, thought*. New York: Harper and Row.
- Heidegger, M. (1973). *Being and time*. Oxford: Oxford University Press.
- Herrera, M., Sani, F., & Bowe, M. (2011). Perceived family continuity: Implications for family identification and psychological well-being. *Revista de Psicología Social*, 26, 387-399.

- Hepburn, A. (2003). *An introduction to critical social psychology*. London: Sage.
- Hidalgo, C. M., & Hernandez, B. (2001). Place attachment: Conceptual and empirical questions. *Journal of Environmental Psychology, 21*, 273-281.
- Hinkle, S., Taylor, L. A., Fox-Cardamone, D. L., & Crook, K. F. (1989). Intragroup identification and intergroup differentiation: A multicomponent approach. *British Journal of Social Psychology, 28*, 305-317.
- Hiscock, R., Kearns, A., Macintyre, S., & Ellaway, A. (2001). Ontological security and psychosocial benefits from the home: qualitative evidence on issues of tenure. *Housing, Theory and Society, 18*, 50-66.
- Hogg, M.A. & Vaughan, G.M. (2010). *Social psychology*. Harlow: Pearson Education.
- Hopkins, N., & Dixon, J. (2006). Space, place, and identity: Issues for political psychology. *Political Psychology, 27*, 173-185.
- Hopkins, N., Reicher, S., & Harrison, K. (2006). Young people's deliberations on geographic mobility: Identity and cross-border relocation. *Political Psychology, 27*, 227-245.
- Hume, D. (1739/2000). *A treatise on human nature*. Oxford: Oxford University Press.
- Hummon, D. (1992). Community attachment: Local sentiment and sense of place. In I. Altman, & S. Low (Eds.) *Place attachment* (pp. 253-278). New York: Plenum.
- James, W. (1890/1981). *The principles of psychology*. New York: Holt.
- Jetten, J., & Postmes, T. (2006). Introduction: The puzzle of individuality and the group. In T. Postmes & J. Jetten (Eds.), *Individuality and the group* (pp. 1-10). London: Sage.
- Jetten, J., & Hutchison, P. (2011). When groups have a lot to lose: Historical continuity enhances resistance to a merger. *European Journal of Social Psychology, 41*, 335-343.
- Jetten, J., Spears, R., & Manstead, A. S. R. (2001). Similarity as a source of discrimination: The role of group identification. *European Journal of Social Psychology, 31*, 621-640.
- Johnson, J.D. & Lecci, L. (2003). Assessing anti-white attitudes and predicting perceived racism: The Johnson-Lecci Scale. *Personality and Social Psychology Bulletin, 29*, 299-312.

- Jöreskog, K.G. & Sörbom, D. (2004). *LISREL 8.8*. Scientific Software International, Inc.
- Jorgensen, B. S., & Stedman, R. C. (2001). Sense of place as an attitude: Lakeshore owners' attitudes towards their properties. *Journal of Environmental Psychology, 21*, 233-248.
- Jorgensen, B. S., & Stedman, R. C. (2006). A comparative analysis of predictors of sense of place dimensions: Attachment to, dependence on, and identification with lakeshore properties. *Journal of Environmental Management, 79*, 316-327.
- Kakar, S. (1996). *Colours of violence: Cultural identities, religion and conflict*. Chicago, IL: University of Chicago Press.
- Kaplan, S., & Kaplan, R. (1982). *Cognition and environment: Functioning in an uncertain world*. New York: Praeger.
- Kasarda, J. D., & Janowitz, M. (1974). Community attachment in mass society. *American Sociological Review, 39*, 328-39.
- Kidder L.H. & Fine, M. (1997). Qualitative inquiry in psychology: A radical tradition. In Fox, D. & Prilleltensky, I. (Eds.). *Critical psychology: An introduction* (pp. 34-50). London: Sage.
- Kierkegaard, S. (1843/2000). Either/or, a fragment of life. In H. V. Hong & E. H. Hong (Eds.), *The essential Kierkegaard* (pp. 37-84). Princeton, NJ: Princeton University Press.
- Kihlstrom, J. F., & Cantor, N. (1984). Mental representations of the self. In L. Berkowitz (Ed.), *Advances in experimental social psychology* (Vol. 17, pp. 1-47). New York: Academic Press.
- King, D. A., & Wynne, L. C. (2004). The emergence of "Family Integrity" in later life. *Family Process, 43*, 7-21.
- Kline, R. B. (1998). *Principles and practice of structural equation modeling*. New York: Guilford Press.
- Knez, I. (2005). Attachment and identity as related to a place and its perceived climate. *Journal of Environmental Psychology, 25*, 207-218.

- Korpela, K. M. (1989). Place-identity as a product of environmental self-regulation. *Journal of Environmental Psychology, 9*, 241-256.
- Korpela, K.M. (1992). Adolescents' favourite places and environmental self-regulation. *Journal of Environmental Psychology, 12*, 249-258.
- Korpela, K. M., & Hartig, T. (1996). Restorative qualities of favorite places. *Journal of Environmental Psychology, 16*, 221-233.
- Korpela, K. M., Hartig, T., Kaiser, F.G., & Fuhrer, U. (2001). Restorative experience and self-regulation in favorite places. *Environment and Behavior, 33*, 572-589.
- Korpela, K. M., & Ylen, M. (2007). Perceived health is associated with visiting natural favourite places in the vicinity. *Health & Place, 13*, 138-151.
- Korpela, K.M., Ylen, M., Tyrvaainen, L., Silvennoinen, H. (2008). Determinants of restorative experiences in everyday favourite places. *Health & Place 14*, 636-652.
- Krupat, E. (1983). A place for place identity. *Journal of Environmental Psychology, 3*, 343-344.
- Kyle, G., Graefe, A., & Manning, R. (2005). Testing the dimensionality of place attachment in recreational settings. *Environment and Behavior, 37*, 153-177.
- Kyle, G., Graefe, A., Manning, R., & Bacon, J. (2004). Effects of place attachment on users' perceptions of social and environmental conditions in a natural setting. *Journal of Environmental Psychology, 24*, 213-225.
- Lalli, M. (1992). Urban-related identity: Theory, measurement, and empirical findings. *Journal of Environmental Psychology, 12*, 285-303.
- Lampinen, J. M., Odegard, T. N., & Leding, J. K. (2004). Diachronic disunity. In D. R. Beike, J. M. Lampinen, & D. A. Behrend (Eds.), *The self in memory* (pp. 227-253). New York: Psychology Press.
- Landau, M. J., Greenberg, J., & Solomon, S. (2008). The never-ending story: A terror management perspective on the psychological function of self-continuity. In F. Sani (Ed.), *Self-continuity: Individual and collective perspectives* (pp. 87-100). Hove: Psychology Press.

- Levine, M., & Thompson, K. (2004). Identity, place, and bystander intervention: Social categories and helping after natural disasters. *The Journal of Social Psychology, 144*, 229-245.
- Lewicka, M. (2008). Place attachment, place identity, and place memory: Restoring the forgotten city past. *Journal of Environmental Psychology, 28*, 209-231.
- Lewicka, M. (2011a). On the varieties of people's relationships with places: Hummon's typology revisited. *Environment and Behaviour, 43*, 676-709.
- Lewicka, M. (2011b). Place attachment: How far have we come in the last 40 years? *Journal of Environmental Psychology, 31*, 207-230.
- Lewis, M. (1990). Self-knowledge and social development in early life. In L. Pervin (Ed.), *Handbook of personality: Theory and research* (pp. 277-300). New York: The Guilford Press.
- Lifton, R. J. (1967). *The future of immortality and other essays for a nuclear age*. New York: Basic Books.
- Locke, J. (1690/1980). *Second treatise of civil government*. Indianapolis, IN: Hackett.
- Low, S. M. (1992). Symbolic ties that bind: Place attachment in the plaza. In I. Altman, & S. Low (Eds.) *Place attachment* (pp. 165-186). New York: Plenum Press.
- Low, S. M. (1996). The anthropology of cities: Imagining and theorizing the city. *Annual Review of Anthropology, 25*, 383-409.
- Low, S. M. & Lawrence-Zúñiga, D. (2003). *The anthropology of space and place: Locating culture*. Malden, MA: Blackwell Publishing.
- Lowenthal, D. (1975). Past time, present place: Landscape and memory. *Geographical Review, 65*, 1-36.
- Lowenthal, D. (1985). *The past is a foreign country*. Cambridge: Cambridge University Press.
- Lynch, K. (1972). *What time is this place?* Cambridge, MA: MIT Press.

- Lyons, E. (1996). Coping with social change: processes of social memory in the reconstruction of identities. In G. M. Breakwell & E. Lyons (Eds.), *Changing European identities: Social psychological analyses of social change* (pp. 31-39). Oxford: Butterworth Heinmann.
- Lutz, A. & Thompson, E. (2003). Neurophenomenology: Integrating subjective experience and brain dynamics in the neuroscience of consciousness. *Journal of Consciousness Studies*, 10, 31-52.
- MacCallum, R. C., & Austin, J. T. (2000). Applications of structural equation modelling in psychological research. *Annual Review of Psychology*, 51, 201-226.
- MacKinnon, D.P., Krull, J.L., & Lockwood, C.M. (2000). Equivalence of the mediation, confounding and suppression effect. *Prevention Science*, 1, 173-181.
- Malpas, J. (2007). *Place and experience: A philosophical topography*. Cambridge: Cambridge University Press.
- Manzo, L. C. (2003). Beyond house and haven: Toward a revisioning of emotional relationships with places. *Journal of Environmental Psychology*, 23, 47-61.
- Manzo, L. (2005). For better or for worse: Exploring multiple dimensions of place meaning. *Journal of Environmental Psychology*, 25, 67-86.
- Markus, H. (1977). Self-schemata and processing information about the self. *Journal of Personality and Social Psychology*, 35, 63-78.
- Markus, H., & Kunda, Z. (1986). Stability and malleability of the self-concept. *Journal of Personality and Social Psychology*, 51, 858-866.
- Markus, H., & Nurius, P. (1986). Possible selves. *American Psychologist*, 41, 954-969.
- Markus, H., & Wurf, E. (1987). The dynamic self-concept: A social psychological perspective. *Annual Review of Psychology*, 38, 299-337.
- Massey, D. (1994). *Space, place and gender*. Cambridge: Polity.

- Massey, D., & Jess, P. (1995). Places and cultures in an uneven world. In D. Massey & P. Jess, (Eds.) *A place in the world?: Places, cultures and globalization* (pp. 215-239). Oxford, UK: Oxford University Press.
- Matore, G. (1962). *L'espace humain*. Paris: La Columbe.
- Mazumdar, S. (2004). Religion and place attachment: A study of sacred places. *Journal of Environmental Psychology, 24*, 385-397.
- Mazumdar, S., & Mazumdar, S. (1993). Sacred space and place attachment. *Journal of Environmental Psychology, 13*, 231-242.
- Mazumdar, S., Mazumdar, S., Docuayan, F., & McLaughlin, C. M. (2000). Creating a sense of place: The Vietnamese-Americans and Little Saigon. *Journal of Environmental Psychology, 20*, 319-333.
- McAdams, D. P. (2001). The psychology of life stories. *Review of General Psychology, 5*, 100-122.
- McAdams, D. P., Bauer, J. J., Sakaeda, A. R., Anyidoho, N. A., Machado, M. A., Magrino-Failla, K., & Pals, J. L. (2006). Continuity and change in the life story: A longitudinal study of autobiographical memories in emerging adulthood. *Journal of Personality, 74*, 1371-1400.
- McAndrew, F. T. (1998). The measurement of rootedness and the prediction of attachment to home towns in college students. *Journal of Environmental Psychology, 18*, 409-417.
- McLean, K. C. (2008). Stories of the young and the old: Personal continuity and narrative identity. *Developmental Psychology, 44*, 254-264.
- Mead, G. H. (1934). *Mind, self and society from the standpoint of a social behaviorist*. Chicago: University of Chicago Press.
- Merleau-Ponty, M. (1962). *Phenomenology of perception*. London: Routledge and Kegan Paul.
- Mikulincer, M., & Shaver, P. R. (2005). Attachment theory and emotions in close relationships: Exploring the attachment-related dynamics of emotional reactions to relational events. *Personal Relationships, 12*, 149-168.

- Milligan, M. J. (1998). Interactional past and potential: The social construction of place attachment. *Symbolic Interaction* 21, 1–33.
- Milligan, M. J. (2003). Displacement and identity discontinuity: The role of nostalgia in establishing new identity categories. *Symbolic Interaction*, 26, 381-403.
- Milligan, M. J. (2007). Buildings as history: The place of collective memory in the study of historic preservation. *Symbolic Interaction*, 30, 105-123.
- Mitty, E. & Flores, S. (2008). There's no place like home. *Geriatric Nursing*, 30, 126-129.
- Moore, J. (2000). Placing home in context. *Journal of Environmental Psychology*, 20, 207-217.
- More, M. (1995). *The diachronic self: Identity, continuity, transformation*. (PhD. dissertation) Available at <http://www.maxmore.com/disscont.htm>.
- Moser, G., & Uzzell, D. L. (2003). Environmental psychology. In T. Milton & M. J. Lerner (Eds.), *Handbook of psychology (Vol. 5 Personality and Social Psychology)*, pp. 419–445). New York: Wiley.
- Nash, C. (2002). Genealogical identities. *Environment and Planning D: Society and Space*, 20, 27–52.
- Nielsen-Pincus, M., Hall, T., Force, J.E., & Wulfhorst, J.D. (2010). Socio-demographics effects on constructs of place bonding. *Journal of Environmental Psychology*. 30, 4, 443-454.
- Neisser, U. (1988). Five kinds of self-knowledge. *Philosophical Psychology*, 1, 35 - 59.
- Neisser, U. (1993). *The perceived self: Ecological and interpersonal sources of self knowledge*. Cambridge: Cambridge University Press.
- Nelson, K. (2003). Self and social functions: Individual autobiographical memory and collective narrative. *Memory*, 11, 125-136.
- Nicolson, P. (2004). Taking quality seriously: The case for qualitative feminist psychology in the context of quantitative clinical research on postnatal depression. In Z. Todd, B. Nerlich, S. McKeown & D.D. Clarke (Eds.) *Mixing methods in psychology: The integration of*

qualitative and quantitative methods in theory and practice (pp. 17-36). Hove: Psychology Press.

Norberg-Schulz, C. (1971). *Existence, space and architecture*. New York: Praeger.

Norberg-Schulz, C. (1980). *Genius loci: Towards a phenomenology of architecture*. London: Rizzoli.

Oakes, P. J. (1987). The salience of social categories. In J. Turner, M. A. Hogg, P. J. Oakes, S. Reicher & M. Wetherell (Eds.), *Rediscovering the social group: A self-categorization theory* (pp. 117-141). Oxford: Basil Blackwell.

Oishi, S., & Schimmack, U. (2010). Residential mobility, well-being, and mortality. *Journal of Personality and Social Psychology*, 98, 980–994.

Olson, E. (2007). *What are we? A study in personal ontology*. Oxford: Oxford University Press.

Onorato, R. S., & Turner, J. C. (2001). The “I,” the “Me, and the “Us: The psychological group and self-concept maintenance and change. In M. B. Brewer & C. Sedikides (Eds.), *Individual self, relational self, collective self* (pp. 147-170). New York: Psychology Press.

Oswald, F., & Rowles, G. D., (2006). Beyond the relocation trauma in old age: New trends in today's elders' residential decisions. In H.-W. Wahl, C. Tesch-Römer, & A. Hoff (Eds.), *New dynamics in old age: Environmental and societal perspectives* (pp. 127–152). Amityville, NY: Baywood.

Oyserman, D. (2004). Self-concept and identity. In M. B. Brewer & M. Hewstone (Eds.), *Self and social identity* (pp. 5–23). Oxford: Blackwell.

Padgett, D. (2007). There's no place like (a) home: Ontological security among persons with a serious mental illness in the United States. *Social Science and Medicine*, 64, 1925-1936.

Pallant, J. (2001). *SPSS survival manual*. Buckingham: Open University Press.

Pancer, S.M. (1997) Social psychology: The crisis continues. In D. Fox & I. Prilleltensky (Eds.) *Critical psychology: An introduction* (pp. 150-165). London: Sage.

Parfit, D. (1987) *Reasons and persons*. Oxford: Clarendon Press.

- Patterson, M. E., & Williams, D. R. (2005). Maintaining research traditions on place: Diversity of thought and scientific progress. *Journal of Environmental Psychology, 25*, 361–380.
- Pavot, W. G., Diener, E., Colvin, C. R., & Sandvik, E. (1991). Further validation of the satisfaction with life scale: Evidence for the cross-method convergence of well-being measures. *Journal of Personality Assessment, 57*, 149-161.
- Potter, J. & Reicher, S. (1987). Discourses of community and conflict: The organization of social categories in accounts of a 'riot'. *British Journal of Social Psychology, 26*, 25-40.
- Potter, J. & Wetherell, M. (1987). *Discourse and social psychology: Beyond attitudes and behaviour*. London: Sage.
- Preacher, K. J., Curran, P. J., & Bauer, D. J. (2006). Computational tools for probing interaction effects in multiple linear regression, multilevel modeling, and latent curve analysis. *Journal of Educational and Behavioral Statistics, 31*, 437-448.
- Preacher, K. J., & Hayes, A. F. (2008). Asymptotic and resampling methods for estimating and comparing indirect effects. *Behavior Research Methods, 40*, 879-891.
- Preacher, K. J., Rucker, D. D. & Hayes, A. F. (2007). Assessing moderated mediation hypotheses: Strategies, methods, and prescriptions. *Multivariate Behavioral Research, 42*, 185–227.
- Prentice, D. A. (2000). The individual self, relational self, and collective self: A commentary. In C. Sedikides & M. B. Brewer (Eds.), *The individual self, relational self, and collective self*. (pp. 315-326). Philadelphia, PA: Psychology Press.
- Pretty, G. H., Chipuer, H. M., & Bramston, P. (2003). Sense of place amongst adolescents and adults in two rural Australian towns: The discriminating features of place attachment, sense of community and place dependence in relation to place identity. *Journal of Environmental Psychology, 23*, 273-287.
- Prilleltensky, I., & Fox, D. (1997). Introducing critical psychology: Values, assumptions, and the status quo. In D. Fox & I. Prilleltensky (Eds.), *Critical psychology: An introduction*. London: Sage.

- Proshansky, H. M. (1976). Comment on social and environmental psychology. *Personality and Social Psychology Bulletin*, 2, 359-363.
- Proshansky, H. M. (1978). The city and self-identity. *Environment and Behavior*, 10, 147-169.
- Proshansky, H. M., Fabian, A. K., & Kaminoff, R. (1983). Place-identity: Physical world socialization of the self. *Journal of Environmental Psychology*, 3, 57-83.
- Quoidbach, J., Hansenne, M., & Mottet, C. (2008). Personality and mental time travel: A differentia approach to auto-noetic consciousness. *Consciousness and Cognition*, 17, 1082-1092.
- Reicher, S. D. (1984a). Social influence in the crowd: Attitudinal and behavioural effects of de-individuation in conditions of high and low group salience. *British Journal of Social Psychology*, 23, 341-350.
- Reicher, S. D. (1984b). The St. Pauls' riot: An explanation of the limits of crowd action in terms of a social identity model. *European Journal of Social Psychology*, 14, 1-21.
- Reicher, S.D. (2008). Making a past fit for the future: The political and ontological dimensions of historical continuity. In F. Sani (Ed.), *Self continuity: Individual and collective perspectives* (pp.145-158). Hove: Psychology Press.
- Reicher, S., Hopkins, N., & Harrison, K. (2006). Social identity and spatial behaviour: The relationship between national category salience, the sense of home, and labour mobility across national boundaries. *Political Psychology*, 27, 247-263.
- Relph, E. (1976). *Place and Placelessness*. London: Pion.
- Relph, E. (1996). Reflections on place and placelessness. *Environmental and Architectural Phenomenology Newsletter*, 7, 14-16.
- Relph, E. (2008). Senses of place and emerging social and environmental challenges, In J. Eyles & A. Williams (Eds.), *Sense of place, health and quality of life* (pp 31-44). Aldershot: Ashgate Publishing Limited.

- Reynolds, K. J., Turner, J.C., Branscombe, N.R., Mavor, K., Bizumic, B., & Subašić, E. (2010). Interactionism in personality and social psychology: An integrated approach to understanding the mind and behaviour. *European Journal of Personality, 24*, 458–482.
- Reynolds, K. J., Turner, J.C., Branscombe, N.R., Mavor, K., Subašić, E., & Bizumic, B. (2012). Social identity and personality processes: Non-Aboriginal Australian identity and Neuroticism. *European Journal of Social Psychology, 42*, 252–262.
- Reynolds, K. J., Turner, J. C., Haslam, S.A., Ryan, M. K., Bizumic, B. & Subašić, E. (2007). Does personality explain in-group identification and discrimination? Evidence from the minimal group paradigm. *British Journal of Social Psychology, 46*, 517–539.
- Riley, R. B. (1992). Attachment to the ordinary landscape. In I. Altman, & S. M. Low (Eds.) *Place attachment* (pp. 13-36). New York: Plenum Press.
- Robson, C. (2011). *Real world research* (3rd ed.) New York: John Wiley and Sons.
- Rowles, G. (1983). Place and personal identity in old age: Observations from Appalachia. *Journal of Environmental Psychology, 3*, 299-313.
- Rowles, G. (1993). Evolving images of place in aging and ‘aging in place’. *Generations, 17*, 65–70.
- Rowles, G. D., & Watkins, J. F. (1993). Elderly migration and development in small communities. *Growth and Change, 24*, 509–538.
- Rubenstein, R. L., & Parmelee, P. A. (1992). Attachment to place and the representation of the life course by the elderly. In I. Altman & S. M. Low (Eds.), *Place attachment* (pp. 139-163). New York: Plenum Press.
- Ryden, K. C. (1993). *Mapping the invisible landscape: Folklore, writing, and sense of place*. Iowa: University of Iowa Press.
- Sacks, O. (1995). *An anthropologist on Mars*. London: Picador.
- Saegert, S., & Winkel, G. H. (1990). Environmental psychology. *Annual Review of Psychology, 41*, 441-477.

- Saldaña, J. (2009). *The coding manual for qualitative researchers* (2nd ed.). London: Sage.
- Sampson, R. & Gifford, S. (2010). Place-making, settlement and well-being: The therapeutic landscapes of recently arrived youth with refugee backgrounds. *Health & Place, 16*, 116-131.
- Sani, F. (2008a). Schism in groups: A social psychological account. *Social & Personality Psychology Compass, 2*, 718-732.
- Sani, F. (2008b). Introduction and overview. In F. Sani (Ed.). *Self-continuity: Individual and collective perspectives* (pp. 1-10). Hove: Psychology Press.
- Sani, F., Bowe, M., Herrera, M., Manna, C., Cossa, T., Miao, X., & Zhou, Y. (2007). Perceived collective continuity: Seeing groups as entities that move through time. *European Journal of Social Psychology, 37*, 1118-1134.
- Sani, F., Bowe, M., & Herrera, M. (2008a). Perceived collective continuity and social well-being. *European Journal of Social Psychology, 38*, 365-374.
- Sani, F., Bowe, M., & Herrera, M. (2008b). Perceived collective continuity: Seeing groups as temporally enduring entities. In F. Sani (Ed.), *Self-continuity: Individual and collective perspectives*. (pp. 159-172). Hove: Psychology Press.
- Sani, F., Herrera, M., & Bowe, M. (2009). Perceived collective continuity and ingroup identification as defence against death awareness. *Journal of Experimental Social Psychology, 45*, 242-245.
- Scharfetter, C. (2003). The self-experience of schizophrenics. In T. Kircher & A. David (Eds.) *The self in neuroscience and psychiatry* (pp. 272–289). Cambridge: Cambridge University Press.
- Schafer, J. L., & Graham, J. W. (2002). Missing data: Our view of the state of the art. *Psychological Methods, 7*, 147-177.
- Scopelliti, M., & Giuliani, M. V. (2004). Choosing restorative environments across the lifespan: A matter of place experience. *Journal of Environmental Psychology, 24*, 423-437.
- Seamon, D. & Sowers, J. (2008). Place and placelessness. In P. Hubbard, R. Kitchin, & G. Valentine (Eds.) *Key texts in human geography* (pp.43-51). London: Sage.

- Silverman, D. (2011). *Interpreting qualitative data: Methods for analysing talk, text and interaction* (4th ed.). London: Sage.
- Sims, A. (2003). *Symptoms in the mind* (3rd ed.). Edinburgh: Saunders.
- Sindic, D., & Reicher, S. D. (2009). 'Our way of life is worth defending': Testing a model of attitudes towards superordinate group membership through a study of Scots' attitudes towards Britain. *European Journal of Social Psychology*, *39*, 114-129.
- Smith, E. R., Murphy, J., & Coats, S. (1999). Attachment to groups: Theory and management. *Journal of Personality and Social Psychology*, *77*, 94-110.
- Solomoil, S., Greenberg, J., & Pyszczynski, T. (1991). A terror management theory of social behavior: The psychological functions of self-esteem and cultural worldviews. In M. E. E. Zanna (Ed.), *Advances in experimental social psychology* (pp. 91-159). San Diego: Academic Press.
- Somerville, P. (1997). The social construction of home. *Journal of Architectural and Planning Research*, *14*, 226-245.
- Soja, E. (1996). *Thirdspace: Journeys to Los Angeles and other real and imagined places*. Cambridge: Blackwell.
- Speller, G. (2000). *A community in transition: a longitudinal study of place attachment and identity processes in the context of an enforced relocation*. (PhD. dissertation). University of Surrey, Surrey, UK.
- Speller, G. M., Lyons, E., & Twigger-Ross, C. L. (2002). A community in transition: The relationship between spatial change and identity processes, *Social Psychological Review*, *4*, 39-58.
- Speller, G. M. & Twigger-Ross, C. L. (2009). Cultural and social disconnection in the context of a changed physical environment. *Geografiska Annaler: Series, B, Human Geography*, *91*, 355-369.
- Stedman, R. C. (2002). Toward a social psychology of place: Predicting behavior from place-based cognitions, attitude, and identity. *Environment and Behavior*, *34*, 561-581.

- Stedman, R. C. (2003). Sense of place and forest science: Toward a program of quantitative research. *Forest Science*, 49, 822-829.
- Steiger, J.H. (2007). Understanding the limitations of global fit assessment in structural equation modelling. *Personality and Individual Differences*, 42, 893-98.
- Stokols, D. (1978). Environmental psychology. In M. R. Rosenzweig & L. W. Porter, (Eds.), *Annual Review of Psychology* (Vol. 29, pp.253-295). Palo Alto, CA: Annual Reviews.
- Stokols, D. & Shumaker, S. A. (1981). People in places: A transactional view of settings. In J. H. Harvey (Ed.), *Cognition, social behavior and the environment* (pp. 441-488). New Jersey: Lawrence Erlbaum Associate Publishers.
- Stokols, D. & Altman, I. (Eds.) (1987). *Handbook of environmental psychology, Volumes 1 and 2*. New York: John Wiley and Sons.
- Stokowski, P. A. (2002). Languages of place and discourses of power: Constructing new senses of place. *Journal of Leisure Research*, 34, 368-382.
- Stott, C., Hutchison, P. & Drury, J. (2001) "Hooligans" abroad? Inter-group dynamics, social identity and participation in collective "disorder" at the 1998 World Cup Finals. *British Journal of Social Psychology*, 40, 359-384.
- Swann, W. B., Jr. (1987). Identity negotiation: Where two roads meet. *Journal of Personality and Social Psychology*, 53, 1038-1051.
- Tabachnick, B.G., & Fidell, L.S. (2007). *Using multivariate statistics* (5th ed.). Boston: Pearson Education.
- Tajfel, H. (1978). *Differentiation between social groups: Studies in the social psychology of intergroup relations*. London: Academic Press.
- Tajfel, H. (1979). Individuals and groups in social psychology. *British Journal of Social and Clinical Psychology*, 18, 183-190.
- Tajfel, H. (1981). *Human groups and social categories*. Cambridge: Cambridge University Press.

- Tajfel, H., & Turner, J. C. (1986). The social identity theory of intergroup behavior. In S. Worchel & W. G. Austin (Eds.), *The psychology of intergroup relations* (pp. 7-24). Chicago: Nelson-Hall.
- Tajfel, H. & Wikes, A. L. (1963). Classification and quantitative judgement. *British Journal of Psychology*, 54, 101-114.
- Taylor, S. (2003). A place for the future? Residence and continuity in women's narratives of their lives. *Narrative Inquiry*, 13, 193–215.
- Taylor, S. (2005). Identity trouble and place of residence in women's life narratives. In N. Kelly, D. Robinson, C. Horrocks, & B. Roberts (Eds.), *Narrative, Memory and Everyday Life* (pp. 97-106). Huddersfield: The University of Huddersfield.
- Taylor, S. (2010). *Narratives of identity and place*. London: Routledge.
- Todd, A., Nerlich, B., Mckeown, S. & Clarke, D. (2004) *Mixing methods in psychology: The integration of qualitative and quantitative methods in theory and practice*. Hove: Psychology Press.
- Troll, L. E., & Skaff, M. M. (1997). Perceived continuity of self in very old age. *Psychology and Aging*, 12, 162-169.
- Trudeau, D. (2006). Politics of belonging in the construction of landscapes: place-making, boundary drawing and exclusion. *Cultural Geographies*, 13, 421-443.
- Tuan, Y.-F. (1974). *Topophilia*. Englewood Cliffs: Prentice-Hall.
- Tuan, Y.-F. (1977). *Place and space: The perspective of experience*. Minneapolis: University of Minnesota Press.
- Tuan, Y.-F. (1980). *Topophilia: A study of environmental perception, attitudes, and values*. Englewood Cliffs: Prentice-Hall.
- Tuan, Y-F. (1999). *Who am I?: An autobiography of emotion, mind, and spirit*. Wisconsin: University of Wisconsin Press.

- Turner, J. C. (1985). Social categorization and the self-concept: A social cognitive theory of group behaviour. *Advances in Group Processes: Theory and Research*, 2, 77-121.
- Turner, J. C., Hogg, M. A., Oakes, P. J., Reicher, S., & Wetherell, M. C. (1987). *Rediscovering the social group: A self-categorization theory*. New York: Basil Blackwell Inc.
- Turner, J. C., & Onorato, R. (1999). Social identity, personality and the self-concept: A self-categorization perspective. In T. R. Tyler, R. M. Kramer, & O. P. John (Eds.), *The psychology of the social self* (pp. 11–46). Mahwah: Lawrence Erlbaum Associates.
- Turner, J. C., & Reynolds, K. J. (2001). The social identity perspective in intergroup relations: Theories, themes, and controversies. In R. Brown & S. Gaertner (Eds.), *Blackwell handbook of social psychology: Intergroup processes* (pp. 133–152). Oxford: Blackwell.
- Turner, J. C., Reynolds, K. J., Haslam, S. A., & Veenstra, K. (2006). Reconceptualizing personality: Producing individuality by defining the personal self. In T. Postmes, & J. Jetten (Eds.), *Individuality and the group: Advances in social identity* (pp. 11-36). London: Sage.
- Twigger, C. L., & Breakwell, G. M. (1994). *Affective place attachment and environmental perceptions*. Paper presented at the 13th Conference of the International Association for People-Environment Studies, Manchester, UK.
- Twigger-Ross, C. L., Bonaiuto, M., & Breakwell, G. M. (2003). Identity theories and environmental psychology. In M. Bonnes, T. Lee & M. Bonaiuto (Eds.), *Psychological theories for environmental issues* (pp. 203-233). Aldershot: Ashgate Publishing Limited.
- Twigger-Ross, C. L., & Uzzell, D. L. (1996). Place and identity processes. *Journal of Environmental Psychology*, 16, 205-220.
- Uzzell, D., Pol, E., & Badenas, D. (2002). Place identification, social cohesion, and environmental sustainability. *Environment and Behavior*, 34, 26-53.
- van Knippenberg, D., van Knippenberg, B. & Bobbio, A. (2008). Leaders as agents of continuity: Self continuity and resistance to collective change. In F. Sani (Ed.), *Self-continuity: Individual and collective perspectives* (pp. 175-186). Hove: Psychology Press.

- van Meijl, T. (2010). Anthropological perspectives on identity: From sameness to difference. In M. Wetherell, & C. T. Mohanty (Eds.). *The Sage handbook of identities* (pp. 63-81), London: Sage Publications Ltd.
- Vignoles, V. L., Regalia, C., Manzi, C., Gollledge, J., & Scabini, E. (2006). Beyond self-esteem: Influence of multiple motives on identity construction. *Journal of Personality and Social Psychology, 90*, 308-333.
- Vignoles, V. L., Manzi, C., Regalia, C., Jemmolo, S. & Scabini, E. (2008). Identity motives underlying desired and feared possible future selves. *Journal of Personality, 76*, 1165-1200.
- Wakslak, C., Nussbaum, S., Liberman, N., & Trope, Y. (2008). Representations of the self in the near and distant future. *Journal of Personality and Social Psychology, 95*, 757-773.
- Wallwork, J., & Dixon, J. A. (2004). Foxes, green fields and Britishness: On the rhetorical construction of place and national identity. *British Journal of Social Psychology, 43*, 21-39.
- Weil, S. (1955). *The need for roots*. Boston: Beacon Press.
- Williams, D.R., & Stewart, S.I. (1998). Sense of place: an elusive concept that is finding a home in ecosystem management. *Journal of Forestry 96*, 18–23.
- Williams, D. R., & Vaske, J. J. (2003). The measurement of place attachment: Validity and generalizability of a psychometric approach. *Forest Science, 49*, 830-840.
- Willig, C. (2001). *Introducing qualitative research in psychology*. Buckingham: Open University Press.
- Wilson, M.S. & Liu, J.H. (2003). Social dominance orientation and gender: The moderating role of gender identity. *British Journal of Social Psychology, 42*, 187–198.
- Wohl, M. J. A., Squires, E. C. & Caouette, J. (2012). We were, we are, will we be?: The social psychology of collective angst. *Social and Personality Psychology Compass, 6*, 379–391.
- Wright, D.B., & Field, A. (2009). Giving your data the bootstrap. *The Psychologist, 22*, 412-413.
- Yuen, B. (2005). Searching for place identity in Singapore. *Habitat International, 29*, 197-214.

APPENDIX ONE

Study 1: Interview Schedule

As the study will take the form of semi-structured interviews there will not be a list of definitive questions. Participants will be asked to describe their lives and their selves in the hope that places will feature in the resultant discussions. Depending upon their response participants will then be asked to describe their experiences and emotions, or lack thereof, concerning that place(s). Participants will then be free to discuss any issues they feel are relevant. There will also be a series of set themes for discussion depending on the nature of interviewee's relationships with place(s). If the participant does not spontaneously discuss these themes, then the interviewer may use a number of prompting open-ended questions based on each theme, to encourage discussion. Recording with digital voice recorder will begin following completion of ethical informed consent procedures.

Part I: Demographic Questions

- Please can you tell me your age?
- Do you have any children?
- What is your nationality?

Part II: Opening Questions

- Opening Question: Can you tell me about yourself and your life? (both chronologically ordered or not are acceptable)
- You mention (X place) a lot, can you tell me a little about it? (potentially repeated for multiple places)
- If no places mentioned: Can you think of any place that has been, or is, of particular importance to you?
 - **Yes** - - Can you tell me why?
 - **No** - - Why do you think that is?

Part III: Place Topics

1. *Residency and Attachment*

- Do you still live in this place?
 - For how long?
 - How long is it since you left there?
- Is this a place you still visit?
 - **Yes** - - Can you tell me why?
 - **No** - - Why do you think that is?
- Would you like to visit or live there again?
 - **Yes** - - Why is this important to you?
 - **No** - - Why not?
- How does it/would it make you feel not being able to go there?

2. *Place Experience*

- Have significant things happened for you in this place?
- Can you describe your experiences in this place?
- Do your experiences in this place make you feel any particular emotions?
- How does this differ from your experiences in other places?

3. *Identity*

- Does this place feel important to you?
 - **Yes** - - Can you tell me why?
 - **No** - - Why do you think that is?
- Does this place say something about who you are as a person?
- Does this place add to your sense of who you are?

4. *Social Groups*

- Does this place give you a sense of connection to other people?
 - **Yes** - - In what ways does this place link you to other people?
 - **No** - - Why do you think that is?

- Is it somewhere that people close to you would also identify with?

5. *Place Loss/Change*

- Has this place stayed the same for you over time?
- Have there been any significant changes to the nature of this place and how has this made you feel?
 - **Yes** - - Why do you think you felt this way?
How have you dealt with this?
 - **No** - - Why do you think this did not affect you?

Part IV: Closing Questions

- Do you have anything you would like to discuss?
- Do you have any questions?

Close and Debrief Participant

APPENDIX TWO

Study 1: Introducing the Participants

P1

Participant 1 is a Greek student at Dundee University, in her mid-twenties. She has travelled from her home town on the island of Crete, to study at Dundee after completing her undergraduate degree in Athens. Before coming to Dundee she studied for two years in France. She describes a happy childhood in Crete, visits often and has a strong desire to go back and live there considering it to be the ideal place to live because her memories are there, her family is there, and the pace of life is slower, more relaxed, and pleasant. Her movements to Athens, France, and Scotland are described as being due to increased opportunity, student needs, and employment. In contrast, her relationship with Crete is expressed in more emotional and identity-related terms, especially through residential history and experience, connections with family and friends, and her future. Her desire to return to Crete is intensified by the importance of specific places there and she finds it hard to cope with watching places like her old school change. Similar place features in Dundee, such as being by the sea, help her though, as does maintaining the idea that she will return to Crete.

P2

Participant 2 is a male student at Dundee University, in his mid-thirties. P2 is Scottish and has resided in several small towns in Perthshire during his life. Despite being widely travelled he has always lived within a 10 miles radius of his place of birth. He expresses connection with several of these small towns, especially the one his parents reside and where he spent his teenage years and the one he currently lives in. His choice to stay in the area is justified in terms of his preference for being in the country surroundings and the security they provide, but he also feels certain opportunities to leave were unwise due to a disability he acquired following an illness in his twenties. This disability has not stopped him travelling and enjoying many places, but he is particularly attached to the village his grandmother lived and where he spent much time during his childhood. He makes sense of his attachments to these places in terms of the memories he has had there, and the sense of familiarity and security he experiences there. He dreams of buying a house there later in life.

P3

Participant 3 is a female student in her late teens from Dumfries, near the Scottish Border. She came to Dundee University following a gap year where she travelled to Africa and remained there for some time after contracting malaria. She spent some time seeking out a career that involved travel but was not accepted into the armed forces. She greatly values the lifestyle in Dundee and enjoys the excitement and challenges of her new life and new friendship circles, although still visits home during prominent holidays. Her choice of university was motivated by being far enough away from home to escape her familiar home surroundings and comforts due to a desire to be independent. Her feelings about Dumfries are mixed as she values the people there, the familiarity and the sense that it will stay the same so that she can return there when she is older. However, she also has a sense that it is inappropriate to remain in one place during young adulthood and therefore feels that it is unsuitable for her and undesirably inescapable and therefore she sees the idea of returning there as not necessarily in line with her aspirations.

P4

Participant 4 is a married man in his early forties living in a town in Perthshire with his wife and two young children. He was born and raised in Corby, England where he attended college before travelling widely during his time in the army. His time in the army was punctuated with a short stay in Northampton, but he returned to the army due to financial reasons. He later left the army following an illness and subsequent health problems. The resultant move to Scotland was chosen to afford a change of pace and the opportunity for a new career near good schools. He has no desire to move back to Corby, as he feels it lost its identity and been devalued following industrial closures in the 1980s. He describes its gradual decline and unsuitability for raising his children, seeing it as a place where people get stuck. He expressed no sense of roots there viewing it as important only because his Aberdeen-born parents remain there. Moreover, he feels 'new towns' like Corby have little history or value he remains open to emigrating to other countries where he has more opportunity.

P5

Participant 5 is a female teacher of EFL (English as a Foreign Language) teacher in her late forties. She was born in the north east of Scotland but moved to England as a young child, where it was made clear that she was Scottish (although this led to a later lack of belonging in both

places due to her English accent). She was brought up with opportunities to move around to study, and so studied in London and then Cardiff. She felt no desire to return home afterwards due to incompatibilities with her parents and so moved around frequently until acquiring her job, which allowed her to travel widely and meet her husband. She expresses a love of anonymity in places and a belief in always moving onwards to new places but describes Brighton as being the only place she felt she belonged due to its 'melting pot' culture and describes her seeking to be part of that group as the instigation for her love of travel. Despite this, she has returned to the north east of Scotland, the place her parents have now returned to and where she lives with her husband and children.

P6

Participant 6 is a divorced mature female student in her mid-fifties with two grown up children. She was born and raised in Newcastle but spent the earlier part of her childhood in Bahrain. After spending a year as a nanny abroad she joined the army instead of returning to Newcastle, and then spent many years in army bases around the UK as a radar operator. She describes her choice to join the army as looking for a safe home, and described her colleagues as constituting her home and family. Despite her siblings being in Newcastle she finds it hard to call it home. Although she feels some connection with Newcastle as part of her identity, her feelings about it are mixed due to unpleasant memories. She now lives in happily in Dundee and dreams of buying a home in nearby Fife with her new partner but still reports making some pleasant visits to places nearby Newcastle where she played as a child.

P7

Participant 7 is a female employee of the University of Dundee in her mid-fifties who was born and raised in Dundee, and now lives there again following a career working for the Wrens (Women's Royal Naval Service). She spent a significant amount of time endeavouring to enter the Wrens because of mobility problems, which meant she was told she would not be suitable. This and her feelings about a period of her life where she was completely immobile in infancy gave her a sense of determination to gain entry and a strong desire to travel. Her career gave her the chance to take part in challenging physical activities and to travel to Malta and Cyprus. She return to England and began a family but soon afterwards she returned to Dundee. She remained in Dundee, carving out a successful career despite initially finding much change and experiencing a lack

belonging, which was coupled with a continuing desire to keep moving on. She equates moving to new places as exciting and a way to challenge the norms of residential mobility and child-rearing.

P8

Participant 8 is a male student from Canada in his mid-twenties. Although he spent the first seven years of his life in Toronto, he moved to Calgary with his family and he considers it his childhood home where he lived happily until he moved to University around three hours away in Edmonton. He enjoyed the independence and after a student exchange in Scotland, chose Dundee for his postgraduate studies. He views this move as pivotal in his life and is very happy in Dundee, although misses home to some degree. He does consider Calgary as significant and his 'base' but enjoys the excitement of moving and aspires to get a job in a large city within the UK, mostly as he sees himself as a 'big city person', but is not set on one particular place. He does however highlight the importance of his childhood house for its connections to his memories and stories and thinks he would like to return to Canada at some time in the future.

P9

Participant 9 is a Scottish male in his late thirties, working in the Dundee area and living in the nearby town of Brechin. He was born on the north eastern coast of Scotland but spent some of his early childhood in England before returning to nearby Brechin at 7 years old. He spent his childhood there until going to study in Edinburgh but after dropping out he started a new life and career in Surrey before moving to London for 15 years until he began to find it difficult and unfulfilling, and returned home to Brechin. The move was a traumatic change and the culture shock led to a breakdown and problems finding work until he began a nursing career and starting a family. He now identifies himself as a rural person as he sees that as more in line with his preferences now and he perceives cities harder to cope with although he finds his attachment to Brechin itself is not as strong as the town and community declines.

P10

Participant 10 is a retired female in her late seventies. She was born in Glasgow but moved with her parent back to their hometown of Lochee, in Dundee as an infant. She was schooled there and has strong memories of the school and the church associated with it, visiting it again many years later. Her childhood was happy although disrupted by World War II and she lived and worked in

Dundee until she married and moved to several Dundee suburbs. When her children were young she moved to the Birmingham area of England, finding the move from rural to city surroundings very difficult and unfamiliar, but she was glad to be in a suburb that reminded her of the size of Lochee. When her children were older she moved back to Dundee and despite finding much change she built a new life there close to her siblings. After a short time back working in London she later retired back in Dundee.

P11

Participant 10 is a Polish female student, in her mid-twenties. She was born and raised in Poland as an only child with her parents moving frequently between residences. She began life in a large industrial Polish city and smaller Polish towns. She spent between the ages of 3 and 6 years in Moscow where she was immersed in a multicultural context, but returned to Poland to a town where she lived happily until early adolescence. This is a place she thinks of fondly, particularly the rural surroundings although she finds it largely changed now and not representative of her nostalgic feelings. She was sent away from her parents to attend high school in a large Polish city and lived there until deciding to make a difficult move to Scotland to acquire funding to study for a degree. She considers a return to the Polish city of her late teenage years as it is the most consonant with her sense of self but overall sees places as significant because of the shared social memories creating within them, and therefore reasons that Scotland would be acceptable to stay in as many Polish friends have now joined her.

P12

Participant 12 is Scottish male postgraduate student in his early twenties. He grew up near the Scottish borders before moving to Crieff as a child, then later to Perth with his father. He came to Dundee to study for his first degree. Following working for an architect in Glasgow he travelled for a year, which he feels is an important part of who he is. He sees his places of residence as fixed in his life history but is drawn to the sorts of 'transient' places visited during travel. He considers Dundee his home because his friends and house are here, but also considers Crieff as significant due to growing up there. He is currently engaged in drawing places from his past, which sees as an intuitive response to visiting these places but also a constructive diary-like record that helps to clarify his identity, and which are to be used in his future.

P13

Participant 13 is a Scottish male, in full-time employment, in his early forties. He was born in Dundee but spent some time in early childhood in Australia until his parents separated and he and his siblings returned to Dundee with his mother. He grew up in a difficult area of Dundee and applied for the army to escape the dangerous youth culture. The job took him all over the world. During his time away he visited Scotland, but felt little attachment to it and reports never having felt emotions related to 'home'. He served in the army for the next 20 years until he finished his service in Ireland and as he was close to home he bought a flat in Dundee for visits, eventually returning only because his family were close by. He aims to leave for Australia where his Dad remains at some time in the future and where he reports never having wanted to leave. One of the main reasons for this desired move is his negative perceptions of the social climate in Dundee and its undesirability.

P14

Participant 14 is female Scottish student in her early twenties, who comes from a Perthshire town where she has lived all her life. She spent a year in South African during a gap year after school and feels that has shaped her life. She went to study for an undergraduate degree in Edinburgh seeking independence and an escape from her hometown where she did not feel she fit with her peers. Although resistant to being close to home, she went to Dundee to study nursing to help with her plans to work abroad. This desire to work abroad was consolidated by a later trip to Rwanda. She feels she would like to show her parents and friends what she can do in Africa, especially as her father spent some time there as a child and she has heard so many stories of Africa during her life. She states overall though, that despite the fond memories she has of it, she seeks a life beyond the limits and people of the small town of her origin and therefore wants a life of continuous travel.

P15

Participant 15 is a female British retired radiographer in her early sixties studying part-time for an art degree in Dundee. She was born and raised in Bournemouth as part of a close family who had lived in the area for many generations. Her job, and her husband's, have taken her to many places, around England, abroad and then to Scotland, where she has remained for the majority of her life raising her children. Although her family all lives in Scotland now, she still refers to

Bournemouth as home, often visiting their old church and its graveyard, where her parents are buried, as well as her grandmother's old house to reminisce. She does not feel this affection for Dundee as it is not associated with her roots despite being there for so long. She does however feel a strong connection to Belgium where she has a lot of family; she feels this place is part of her heritage because she has so many shared family stories located there.

P16

Participant 16 is a British male architecture student in his mid-thirties. He was born in St Andrews and was brought up in a nearby small coastal town. He went to a larger nearby town for secondary school but travelled there from home each day and later went to college nearby. He had several jobs around the locale always staying at home with his parents, but eventually decided to come back to Dundee University when the last job did not work out. This represented a new start for him and his first independent home. He is a postgraduate student with an interest in places and building. He has a strong belief that places should be preserved to retain their history and character and that places give him a sense of well-being, especially St Andrews, which he sees as his original home.

P17

Participant 17 is a British female researcher at Dundee University in her late twenties. She was born in London, but moved around that location many times during her childhood. The longest residential period she experienced was only three years; something she attributes to her mother's love of moving house. She describes her family as spread around so they did not spend much time visiting each other and were not very family-oriented. She later moved to Scotland to study at St Andrews and followed that with a period of postgraduate study then work in Dundee. She enjoys this area due to the activities that are possible here and would not consider moving back to England, and only visits when she needs to. She does not consider any place as particularly significant to her and does not connect any with formative experiences, emotions, or people.

P18

Participant 18 is a retired female in her early sixties studying part time in Dundee. She was born and lived in Edinburgh during early childhood, where both her grandparents lived, but moved to England with her parents and spent her later childhood there until moving to Edinburgh again to

attend college. After a career there as a social worker she moved north for work, and eventually retired in Forfar where she lives with her husband. She identifies Edinburgh as her home though, which she explains in terms of her family history there and her frequent visiting during her life. She maintains her visiting, although no family remain there, but she is very attached to the places in the city that feature in her memories. She enjoys seeing those that remain the same but finds herself disapproving of some of the change. It retains a special emotional element however, in contrast with the practical home feeling that she has in Forfar.

P19

Participant 19 is a British male student in his late twenties. He grew up in a village near Redding until he left for university in Wales, staying first in student halls and then with friends who he went to school with. He stayed there for several years but had mixed feelings about the place, finding some aspects unpleasant. He did not return home, fearing the return would limit his motivations. He therefore left for Japan after a teaching job offer. He remained in Japan for several years, finding the freedom and simplicity, as well as being part of the community, very enjoyable despite some loneliness. On his return, he did not go back to Redding and feels little connection to it, although, he does feel strong ties to his grandparents' farm in the English countryside where he visited during childhood holidays and has treasured memories. He sees the pleasantness of experiences in both places as determining these connections but considers Dundee as his home now, a place he ended up in only by chance due to being accepted to university.

P20

Participant 20 is a British female in her early fifties born in England. She was born in Ipswich but moved around every few months as her parents were travelling performers and had to move where there was work. She eventually went to boarding school between 6 and 10 years old, until the fees were too much and she went to school in London where her parents were working at the time. Their rented flat there was her first fixed abode and she remained there for ten years before going to college in Plymouth. After college she returned to her parents' house where she had a part of the house but spent much time in Cornwall where her father was working. She moved to Scotland after getting married and having children because of a job offer. Scotland became a home for her, which she attributes to its Celtic similarity to Cornwall. She considers it hard to think of a specific

place as significant, but felt a strong connection to the caravan she shared with her parents, which signified a childhood home for her.

APPENDIX THREE

Study 1: Transcription Notation

I:	Interviewer's speech
P number:	Participant's speech
[]	Square brackets used to indicate overlapping speech, a gap in speech filled with an approximation of the text. Also used when anonymising information.
(.)	Just noticeable pause
(...)	Long pause
°word°	Material between "degree signs" is quiet talk
((sobbing)) ((laughing))	Transcriber's attempt at representing something hard, or impossible, to write phonetically
<i>Italics</i>	Used to note emphasis in participants' expression

Notation adapted from Antaki, Billig, Edwards, & Potter (2003) for the purposes of Study 1 transcription.

Reference:

Antaki, C., Billig, M., Edwards, D., & Potter, J. (2003). Discourse analysis means doing analysis: A critique of six analytic shortcomings, *Discourse Analysis Online*, 1. Available from: <http://www.shu.ac.uk/daol/articles/v1/n1/a1/antaki2002002-t.html>. Accessed 24th March 2008.

APPENDIX FOUR

Study 2: Questionnaire

An Exploration of People and Place Relationships

INVITATION TO TAKE PART IN A RESEARCH STUDY

You are being asked to take part in a research study, which is aimed at investigating the relationships between people and places. This research makes up part of the PhD research of Mhairi Bowe and is supervised by Dr Fabio Sani, University of Dundee.

PURPOSE OF THE RESEARCH STUDY

This study involves completing an anonymous questionnaire including questions about a significant place in your life in order to investigate the psychological aspects of people-place relationships. This study is aimed at furthering understanding of these relationships for the purposes of social psychological and environmental theory.

TIME COMMITMENT

The study will require only around 15 minutes to complete and will be completed in just one session.

TERMINATION OF PARTICIPATION

You may decide to stop taking part in the research study at any time without explanation and you will be able to miss out any questions that you feel you do not wish to answer.

RISKS

There are no known risks for you in this study

COST, REIMBURSEMENT AND COMPENSATION

Your participation in this study is voluntary but you may leave your email address if you would like to be entered into a prize draw for a £30 Amazon.co.uk voucher. The winner will be announced via email at conclusion of the study.

CONFIDENTIALITY/ANONYMITY

The data we collect do not contain any personally sensitive information about you except your age and nationality. No one will link the data you provide to your identity and name as all questionnaires will be completed anonymously. Any publication of the results of this study will not identify you by name.

FOR FURTHER INFORMATION ABOUT THIS RESEARCH STUDY CONTACT:

Mhairi Bowe

Postgraduate Student

School of Psychology

University of Dundee

Dundee

Scotland, DD1 4HN

Tel: +44 (0)1382 388254

E-mail: m.z.bowe@dundee.ac.uk

The University of Dundee Research Ethics Committee has reviewed and approved this research study

Informed Consent

By selecting the 'I agree' button below you are indicating that you have read and understood the participant information and that you agree to take part in this study.

- **Yes, I agree**
- **No, I do not want to take part**

Section A

1. I can reconnect to my past in this place

totally disagree 1 2 3 4 5 6 7 *totally agree*

2. This place links me to my memories

totally disagree 1 2 3 4 5 6 7 *totally agree*

3. This place is not linked to any significant events in my life

totally disagree 1 2 3 4 5 6 7 *totally agree*

4. My past is rooted in this place

totally disagree 1 2 3 4 5 6 7 *totally agree*

5. This place is not connected to my history

totally disagree 1 2 3 4 5 6 7 *totally agree*

6. If this place is lost, I will lose a link with my past

totally disagree 1 2 3 4 5 6 7 *totally agree*

7. This place represents periods from my life

totally disagree 1 2 3 4 5 6 7 *totally agree*

8. This place connects me to my past

totally disagree 1 2 3 4 5 6 7 *totally agree*

9. I sense no link to my past in this place

totally disagree 1 2 3 4 5 6 7 *totally agree*

10. This place links me to previous times in my life

totally disagree 1 2 3 4 5 6 7 *totally agree*

11. I will have new experiences in this place in the future

totally disagree 1 2 3 4 5 6 7 *totally agree*

12. This place will not continue to be a part of my life

totally disagree 1 2 3 4 5 6 7 *totally agree*

13. Part of me will survive in this place

totally disagree 1 2 3 4 5 6 7 *totally agree*

14. This place will continue to represent me in the future

totally disagree 1 2 3 4 5 6 7 *totally agree*

15. My memories will be preserved for the future in this place

totally disagree 1 2 3 4 5 6 7 *totally agree*

16. This place links me to my future

totally disagree 1 2 3 4 5 6 7 *totally agree*

17. I will always be connected to this place

totally disagree 1 2 3 4 5 6 7 *totally agree*

18. This place will not be significant for me in the future

totally disagree 1 2 3 4 5 6 7 *totally agree*

19. Part of me will be preserved in this place

totally disagree 1 2 3 4 5 6 7 *totally agree*

20. I will not always be connected to this place

totally disagree 1 2 3 4 5 6 7 *totally agree*

21. This place has features that allow me to express the kind of person I am

totally disagree 1 2 3 4 5 6 7 *totally agree*

22. This place does not offer what I want in my life

totally disagree 1 2 3 4 5 6 7 *totally agree*

23. This place has features I value

totally disagree 1 2 3 4 5 6 7 *totally agree*

24. This place has the qualities I look for

totally disagree 1 2 3 4 5 6 7 *totally agree*

25. This is the kind of place I can feel like me

totally disagree 1 2 3 4 5 6 7 *totally agree*

26. This place does not have the type of qualities that suit me

totally disagree 1 2 3 4 5 6 7 *totally agree*

27. This place can provide me with the things I feel I need

totally disagree 1 2 3 4 5 6 7 *totally agree*

28. This place has the characteristics that are important to my life

totally disagree 1 2 3 4 5 6 7 *totally agree*

29. I can be who I want to be in this place

totally disagree 1 2 3 4 5 6 7 *totally agree*

30. This place does not match the way I see myself

totally disagree 1 2 3 4 5 6 7 *totally agree*

Now please try to think about whether this place links you to a group of other people and answer the following questions with that group in mind. Examples of a group might include your family group, your national group, group of friends or peers and so on.

Please indicate the nature of this group below

.....

Section B

1. This place is connected to the past of my group

totally disagree 1 2 3 4 5 6 7 *totally agree*

2. This place links my group to its history

totally disagree 1 2 3 4 5 6 7 *totally agree*

3. This place is not linked to any significant group events from the past

totally disagree 1 2 3 4 5 6 7 *totally agree*

4. The history of my group is rooted in this place

totally disagree 1 2 3 4 5 6 7 *totally agree*

5. My group has no history in this place

totally disagree 1 2 3 4 5 6 7 *totally agree*

6. If this place is lost my group will loose a link to its past

totally disagree 1 2 3 4 5 6 7 *totally agree*

7. This place represents periods in my group's history

totally disagree 1 2 3 4 5 6 7 *totally agree*

8. This place is unrelated to the past of my group

totally disagree 1 2 3 4 5 6 7 *totally agree*

9. This place is connected to the past of my group

totally disagree 1 2 3 4 5 6 7 *totally agree*

10. This place is linked to previous generations of my group

totally disagree 1 2 3 4 5 6 7 *totally agree*

11. New group histories will be made in this place

totally disagree 1 2 3 4 5 6 7 *totally agree*

12. This place will not continue to be significant to people in my group

totally disagree 1 2 3 4 5 6 7 *totally agree*

13. My group's culture and tradition will live on here

totally disagree 1 2 3 4 5 6 7 *totally agree*

14. This place will continue to represent my group in the future

totally disagree 1 2 3 4 5 6 7 *totally agree*

15. This place will help preserve the memories of my group for the future

totally disagree 1 2 3 4 5 6 7 *totally agree*

16. Future generations of my group will be linked to this place

totally disagree 1 2 3 4 5 6 7 *totally agree*

17. My group will always be connected to this place

totally disagree 1 2 3 4 5 6 7 *totally agree*

18. This place will not be significant for my group in the future

totally disagree 1 2 3 4 5 6 7 *totally agree*

19. My group will be preserved in this place

totally disagree 1 2 3 4 5 6 7 *totally agree*

20. My group will not always be connected to this place

totally disagree 1 2 3 4 5 6 7 *totally agree*

21. This place has features that allow my group to express the kind of people they are

totally disagree 1 2 3 4 5 6 7 *totally agree*

22. This place does not offer my group what it wants

totally disagree 1 2 3 4 5 6 7 *totally agree*

23. This place has the types of features that my group values

totally disagree 1 2 3 4 5 6 7 *totally agree*

24. This place has qualities that people in my group look for

totally disagree 1 2 3 4 5 6 7 *totally agree*

25. This is the kind of place people in my group can feel like themselves

totally disagree 1 2 3 4 5 6 7 *totally agree*

26. This place does not have the type of qualities that suit my group

totally disagree 1 2 3 4 5 6 7 *totally agree*

27. This place can provide people in my group with what they need

totally disagree 1 2 3 4 5 6 7 *totally agree*

28. This place has characteristics that are important to people from my group

totally disagree 1 2 3 4 5 6 7 *totally agree*

29. People from my group are able to be themselves in this place

totally disagree 1 2 3 4 5 6 7 *totally agree*

30. This place does not match the way my group defines itself

totally disagree 1 2 3 4 5 6 7 *totally agree*

Please answer the following section with just yourself in mind.

Section C

1. This place makes my life feel temporary

totally disagree 1 2 3 4 5 6 7 *totally agree*

2. This place gives me a sense of stability in my life

totally disagree 1 2 3 4 5 6 7 *totally agree*

3. This place makes me feel safe

totally disagree 1 2 3 4 5 6 7 *totally agree*

4. This place makes me feel secure

totally disagree 1 2 3 4 5 6 7 *totally agree*

5. This place feels meant to be

totally disagree 1 2 3 4 5 6 7 *totally agree*

6. This place feels incidental

totally disagree 1 2 3 4 5 6 7 *totally agree*

7. I know what to expect in this place

totally disagree 1 2 3 4 5 6 7 *totally agree*

8. This place gives me a sense of permanence

totally disagree 1 2 3 4 5 6 7 *totally agree*

9. This place has been here for a long time and will continue to be here in the future

totally disagree 1 2 3 4 5 6 7 *totally agree*

10. This place will be experienced by people in the future as it was in the past and is now.

totally disagree 1 2 3 4 5 6 7 *totally agree*

11. This place has a sense of permanence

totally disagree 1 2 3 4 5 6 7 *totally agree*

12. This essence of this place will remain unchanged in the future

totally disagree 1 2 3 4 5 6 7 *totally agree*

13. This place will change beyond recognition

totally disagree 1 2 3 4 5 6 7 *totally agree*

14. This is not the place it used to be

totally disagree 1 2 3 4 5 6 7 *totally agree*

15. This place is preserved in time

totally disagree 1 2 3 4 5 6 7 *totally agree*

16. Whilst places always change, the essence of this place will stay the same.

totally disagree 1 2 3 4 5 6 7 *totally agree*

17. I know this place very well

totally disagree 1 2 3 4 5 6 7 *totally agree*

18. I defend it when somebody criticizes it

totally disagree 1 2 3 4 5 6 7 *totally agree*

19. I miss it when I am not here

totally disagree 1 2 3 4 5 6 7 *totally agree*

20. I don't like this place

totally disagree 1 2 3 4 5 6 7 *totally agree*

21. I feel secure here

totally disagree 1 2 3 4 5 6 7 *totally agree*

22. I am proud of this place

totally disagree 1 2 3 4 5 6 7 *totally agree*

23. This place is a part of myself

totally disagree 1 2 3 4 5 6 7 *totally agree*

24. I have no influence on its affairs

totally disagree 1 2 3 4 5 6 7 *totally agree*

25. I want to be involved in what is going on here

totally disagree 1 2 3 4 5 6 7 *totally agree*

26. I leave this place with pleasure

totally disagree 1 2 3 4 5 6 7 *totally agree*

27. I would not like to move out from here

totally disagree 1 2 3 4 5 6 7 *totally agree*

28. I am rooted here

totally disagree 1 2 3 4 5 6 7 *totally agree*

29. I feel like this place is a part of me

totally disagree 1 2 3 4 5 6 7 *totally agree*

30. This place means a lot to me

totally disagree 1 2 3 4 5 6 7 *totally agree*

31. I identify strongly with this place

totally disagree 1 2 3 4 5 6 7 *totally agree*

32. This place is very special to me

totally disagree 1 2 3 4 5 6 7 *totally agree*

33. This place has made me who I am

totally disagree 1 2 3 4 5 6 7 *totally agree*

34. This place is engrained in me

totally disagree 1 2 3 4 5 6 7 *totally agree*

35. This feels like my place

totally disagree 1 2 3 4 5 6 7 *totally agree*

36. I don't feel a link to this place

totally disagree 1 2 3 4 5 6 7 *totally agree*

37. This place is part of what I have become

totally disagree 1 2 3 4 5 6 7 *totally agree*

38. This place represents something about who I am

totally disagree 1 2 3 4 5 6 7 *totally agree*

The following sections do not relate to any specific place.

Please specify your degree of agreement or disagreement with the following statements. Please note that you must tick one box corresponding to one of the seven response options available.

I totally disagree	I disagree	I slightly disagree	I neither agree nor disagree	I slightly agree	I agree	I totally agree
[]	[]	[]	[]	[]	[]	[]

Section D

1. I prefer to move around between places rather than have links with any one place

totally disagree 1 2 3 4 5 6 7 *totally agree*

2. I do not have a sense of connection to any place

totally disagree 1 2 3 4 5 6 7 *totally agree*

3. I prefer to have roots in one place

totally disagree 1 2 3 4 5 6 7 *totally agree*

4. I do not maintain links with any place

totally disagree 1 2 3 4 5 6 7 *totally agree*

5. I like new places but I like to know I have a place to come back to

totally disagree 1 2 3 4 5 6 7 *totally agree*

6. Moving around is good but I always keep a base at home

totally disagree 1 2 3 4 5 6 7 *totally agree*

7. New places allow me to be who I want to be and not who people expect me to be.

totally disagree 1 2 3 4 5 6 7 *totally agree*

8. After living in one place for a while, I get the urge to move on

totally disagree 1 2 3 4 5 6 7 *totally agree*

9. I feel there is a sense of discontinuity between the phases of my life

totally disagree 1 2 3 4 5 6 7 *totally agree*

10. I have a sense of disconnection between the person I used to be and the person I am now

totally disagree 1 2 3 4 5 6 7 *totally agree*

11. I am the same person now as I was in the past

totally disagree 1 2 3 4 5 6 7 *totally agree*

Please consider how you might convince somebody that despite all the changes that have taken place in your life you are still the same person. Now, please tick which statement below best describes the way you see yourself.

1. *Although time has passed and I have experienced some changes, I feel that I have some core features or characteristics that make up a part of me that has remained unchanged.*

OR

2. *Although time has passed and I have experienced some changes, I feel that my life is like an ongoing story where each phase of my life is like a part of the story that is connected to the next.*

We would now like to ask you for some general information.

Sex: Male [] Female [] **Do you have any children?** YES [] NO []

Nationality:..... **Age:**.....

Employment Status: Employed [] Student [] Unemployed []
Stay-at-home Parent [] Retired []

Are you resident in the place you answered in relation to? YES [] NO []

If yes, for how long?

Have you ever been resident in the place you answered in relation to? YES [] NO []

If yes, for how long?

Thank you very much for your participation!

APPENDIX FIVE

Study 3: The Satisfaction with Life Scale

Below are five statements that you may agree or disagree with. Using the 1 - 7 scale below, indicate your agreement with each item by placing the appropriate number on the line preceding that item. Please be open and honest in your responding.

- 7 - Strongly agree
- 6 - Agree
- 5 - Slightly agree
- 4 - Neither agree nor disagree
- 3 - Slightly disagree
- 2 - Disagree
- 1 - Strongly disagree

___ In most ways my life is close to my ideal.

___ The conditions of my life are excellent.

___ I am satisfied with my life.

___ So far I have gotten the important things I want in life.

___ If I could live my life over, I would change almost nothing.

Reference:

Diener, E., Emmons, R. A., Larsen, R. J., & Griffin, S. (1985). The Satisfaction with Life Scale. *Journal of Personality Assessment*, 49, 71-75.

We would now like to ask you for some general information.

Sex: Male [] Female [] **Age:**.....

Nationality.....

Thank you very much for your participation!