

# Northumbria Research Link

Citation: Paudel, Rupak, Poliak, Juraj, Ghassemlooy, Zabih, Wilfert, Otakar and Leitgeb, Erich (2014) Curved Track Analysis of FSO Link for Ground-to-Train Communications. *Radioengineering*, 23 (1). pp. 452-459. ISSN 1210-2512

Published by: Brno University of Technology

URL: [http://www.radioeng.cz/fulltexts/2014/14\\_01\\_0452\\_0...](http://www.radioeng.cz/fulltexts/2014/14_01_0452_0...)  
<[http://www.radioeng.cz/fulltexts/2014/14\\_01\\_0452\\_0459.pdf](http://www.radioeng.cz/fulltexts/2014/14_01_0452_0459.pdf)>

This version was downloaded from Northumbria Research Link:  
<http://nrl.northumbria.ac.uk/16478/>

Northumbria University has developed Northumbria Research Link (NRL) to enable users to access the University's research output. Copyright © and moral rights for items on NRL are retained by the individual author(s) and/or other copyright owners. Single copies of full items can be reproduced, displayed or performed, and given to third parties in any format or medium for personal research or study, educational, or not-for-profit purposes without prior permission or charge, provided the authors, title and full bibliographic details are given, as well as a hyperlink and/or URL to the original metadata page. The content must not be changed in any way. Full items must not be sold commercially in any format or medium without formal permission of the copyright holder. The full policy is available online: <http://nrl.northumbria.ac.uk/policies.html>

This document may differ from the final, published version of the research and has been made available online in accordance with publisher policies. To read and/or cite from the published version of the research, please visit the publisher's website (a subscription may be required.)

[www.northumbria.ac.uk/nrl](http://www.northumbria.ac.uk/nrl)



# Curved Track Analysis of FSO Link for Ground-to-Train Communications

Rupak PAUDEL<sup>1</sup>, Juraj POLIAK<sup>2</sup>, Zabih GHASSEMLOOY<sup>1</sup>, Otakar WILFERT<sup>2</sup>, Erich LEITGEB<sup>3</sup>

<sup>1</sup>Optical Communications Research Group, Faculty of Engineering and Environment, Northumbria University, Newcastle upon Tyne, United Kingdom

<sup>2</sup>Institute of Radio Electronics, Brno University of Technology, Brno, Czech Republic

<sup>3</sup>Institute of Broadband Communications, Graz University of Technology, Graz, Austria

z.ghassemlooy@northumbria.ac.uk

**Abstract.** *In this work, a free space optical (FSO) link for the ground-to-train (G2T-FSO) communications is proposed. Analytical analysis is carried out for the curved rail tracks. We show that the transmitter divergence angle, the transmit power and the size of the concentration lens need to increase for the curved section of the rail track compared to the straight track. We derive the analytical expression for the received power level based on the link geometry for the case of the curved track. In the worst case scenario when the curvature radius is 120 m, the transmit power at the optical base station (BS) needs to increase by over 2 dB when the concentration lens radius is increased by 5 times. Analyses also show that the received power along the track increases with the curvature radius for the same transmit power and receiver optics illustrating the effect due to link geometry. Additionally, the signal-to-noise ratio (SNR) and the bit error rate (BER) performance of the system for the curved track with different curvature radii is analysed at data rates of 10 Mbps and 100 Mbps for an additive white Gaussian noise (AWGN) channel showing a good agreement between the theoretical and the simulated BER. Finally, effect of scintillations on the G2T-FSO link performance is discussed.*

## Keywords

Free space optical, ground-to-train, base station, link geometry.

## 1. Introduction

Research and development in the field of free space optical (FSO) technology is gaining popularity and momentum as an alternative complementary to the well-established radio frequency (RF) wireless systems. FSO solutions provide cost-effective, high-speed wireless connectivity for a variety of applications, including enterprise connectivity, data and voice, entertainment and on line video, disaster recovery, healthcare, education, surveillance and military. FSO systems offer enough bandwidth to service all of your data

transmission needs, requiring no operating licenses, or recurring leased line charges and being inherently secure data transmission with no means of interception or interference [1-3]. FSO systems are also desirable in places such as campuses and hospitals where there are restrictions in place for using RF wireless based technologies [4]. The link length of FSO systems can vary from the indoor short range (few metres) to the outdoor of a few kilometres. Outdoor links with a data rate  $> 10$  Gb/s over a few kilometres have been reported in [5]. For indoor links, data rates up to Gb/s for wireless home access networks can be achieved with much wider coverage area [6]. The main challenge for the wireless optical system is the very limited mobility compared to RF cellular wireless systems. However, the FSO technology is now being tested for a mobile condition as in [7] where a 10 MHz mobile FSO communication link with low power consumption, light weight and low cost is demonstrated.

There is a growing demand for the access to high speed wireless network by the end users particularly when they are on the move (e.g. on trains, buses, ships etc.). At the present time, a limited RF based wireless network is provided by the train operator at a low data rate (below 50 Mbps) when the train is on the move. The new version of mobile WiMAX (Worldwide Interoperability for Microwave Access) which is IEEE802.16m complies with the requirements of IMT-Advanced (International Mobile Telecommunication-Advanced) and theoretically aims at providing data rates in excess of 100 Mbps for the high mobility environment [8]. In practice, the available data rate in trains is much lower than the theoretical data rate as the bandwidth is shared among many users. Although RF based communications is a promising technology for the fixed wireless local area network (WLAN), its effectiveness is limited when used in trains offering very limited connection capabilities. Radio-over-fibre (RoF) systems have been reported in [9, 10] in order to provide broadband wireless access in high speed trains, which is an integration of RF wireless and optical systems. The main issue with the RoF system would be the frequent band switching and complex optical routing, which limits the based station (BS) coverage length [11]. FSO communications could be adopted in order

to offer higher data rates and provide seamless data services to the passengers traveling by train. For a truly office-to-office network capabilities within train, the system can benefit from a combination of FSO and visible light communications (for data distribution with the coaches), which can be linked to the existing mobile BS or to the fibre-optic backbone network.

G2T-FSO communication has been reported previously [12, 13] where an FSO link only for the straight track is investigated. In [12], the received optical power and the Q-factor analysis for G2T-FSO link for a model train (1:75 scale) has been carried out for a track length of 1 m, which could be scaled up for 75 m for the real case. A G2T-FSO system is proposed in [13] using the FSO technology where a narrow laser beam is used and with tracking between ground transceiver and train transceiver achieved for 700 ms. The ground transceivers were located at 100 m apart alongside the train track. The field trials carried out were for the straight track. This paper reports numerical evaluation of G2T-FSO communications for the case of curved track. The BER performance of the proposed system for the curved track scenario is investigated for different curvature radii.

The paper is organised as follows: the proposed G2T-FSO communications link is described in Section 2. Numerical analysis of the link geometry for a straight and a curved track is shown in Section 3. Simulation results showing a comparison between the straight and the curved track are presented in Section 4 which also covers a detailed analysis for the curved track. Finally, Section 5 concludes the paper.

## 2. Proposed System Model

The proposed G2T communications system consists of a number of BSs located along the train tracks and the transceivers are positioned on the roof of the train coaches. The geometrical model for the G2T-FSO link for a straight track is shown in Fig. 1 where the BS is positioned at a distance  $d_1$  from the track with an offset distance of  $d_2$  from the shortest coverage point. Based on this geometry; the estimation of the transmit beam divergence  $\theta$  is given by [14]:

$$\theta = \arctan\left(\frac{d_1 L}{d_1^2 + d_2 L + d_2^2}\right). \quad (1)$$

Currently the proposed scheme does not consider an automatic pointing, acquisition and tracking (PAT) system, but future studies will investigate them. In order to maintain full coverage and ensure quality system performance, the optical power distribution along the track needs to be analysed in relation to the transmit beam divergence angle  $\theta$ . For systems with a wide transmit beam misalignment is minimised unlike the case of a narrow transmit beam. The proposed system is similar to a cellular-like concept where the coverage area from each BS acts like an RF cell. As long as the train is within the coverage area of one BS, the communications will take place between the BS and the optical receiver mounted on the train.

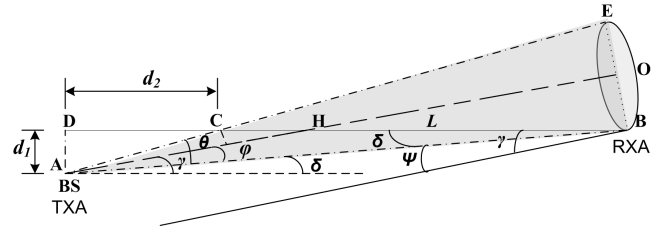

Fig. 1. Proposed link geometry for the train in straight track.

## 3. Numerical Analysis

In this Section, the link geometry for a train travelling along a straight track is shown and the angle of irradiance and the incidence angle are estimated accordingly [14]. The main contribution consists of geometrical modelling of the G2T-FSO link for the case of curved tracks.

### 3.1 Straight Track

From Fig. 1, the transmit irradiance angle  $\varphi$  becomes equal to the receiver incident angle  $\psi$ , which can be given as:

$$\varphi = \psi = \gamma - \delta = \frac{\theta}{2}. \quad (2)$$

As can be shown in [14], the received optical power  $P_r$  can be written as:

$$P_r = \frac{A_{det} P_{tx} (m+1) T_S(\psi) \cos^m(\varphi) n^2 \cos(\psi)}{2\pi \sin^2(\psi_c) [L \cos(\gamma) + x \cos(\theta_{1/2})]^2} \quad (3)$$

where  $A_{det}$  is the physical area of the detector,  $P_{tx}$  is the transmitted power,  $m$  is the order of Lambertian emission,  $T_S$  is the filter transmission factor,  $\psi$  is the incident angle of the receiver,  $\psi_c$  is the receiver field of view,  $\gamma$  is the tilt angle,  $L$  stands for the location of the transmitter along the track, and  $x$  is the distance between points A and C (Fig. 2). The essential parameters to know are  $\psi$  and  $\varphi$ , which were analysed in [14]. In the next section we derive the angles for case of the curved tracks. This is followed by determining the optimal geometry for the system in order to ensure maximum link availability.

### 3.2 Curved Track

The FSO link equation according to (3) does not take into account the curvature of the rail track. Analogically to the straight track scenario, in case of the curved tracks, the worst case scenario is when the distance  $L$  between transmitter (TX) and receiver (RX) is largest. In addition to that, the tilt angle  $\delta$  is not only given by the distance  $d_1$  but also by the curvature of the tracks  $R$ . A section of the curved rail track is schematically shown in Fig. 2.

First, we define the angle  $\omega$  at the intersection of the centre of the curve and points of RX and TX as:

$$\omega = \frac{L + d_2}{R} \quad (4)$$



## 4. Simulation Results

### 4.1 Geometry-Based Results

In order to simulate the optical link performance along the curved track a simulation of the received optical power  $P_r$  along the track length  $L$  was carried out and the result is shown in Fig. 3. All important simulation parameters adopted are shown in Tab. 1 where parameters for straight track simulation are mentioned for better comparison. For the rail track the typical bend could have curvature radius of 200–500 m. However, the bends can be sharper in some cases where  $R$  might be as small as 100 m. Hence, three different curvature radii of 120, 240 and 500 m are investigated in this paper in order to analyse the effect of  $R$  on the required divergence angle. We note that for the curved track with a curvature radius  $R$  of 120 m the additional optical transmit power is 10 mW and the concentrator radius  $R_{coll}$  is increased by 5 times [14]. As the worst case scenario we have assumed that  $R = 120$  m. This is represented by the lowest power profile in Fig. 3.

Parameter	Symbol	Value
Transmit power	$P_{tx}$	15 mW (st.) / 25 mW (curved)
Wavelength	$\lambda$	850 nm
Transmitter divergence	$\theta$	$3.2^\circ$ (st.) / $24.69^\circ$ ( $R = 120$ m)
Active area of photodetector	$A_{det}$	$7 \text{ mm}^2$
Responsivity	$\mathfrak{R}$	0.59 A/W
Receiver sensitivity	$S_r$	-36 dBm @ 10 Mbps
Concentrator focal length	$F$	50 mm
Concentrator radius	$R_{coll}$	25 mm (st.) / 125 mm (curved)
Concentrator semi FOV	$\psi_c$	$5.15^\circ$ (st.) / $1.02^\circ$ (curved)
Coverage length	$L$	75 m
Vertical separation	$d_1$	1 m
Horizontal separation	$d_2$	15 m
Refractive index of lens	$n$	1.5
Filter transmission coefficient	$T_S(\psi)$	0.8
Curvature radius	$R$	120/240/500 m

Tab. 1. Simulation parameters.

A relatively small FOV of the receiver is caused by a larger radius of the concentrator lens according to the constant radiance theorem [15], which illustrates the relationship between the receiver FOV, collection area of the lens and the photodetector area. To increase the FOV one may adopt (i) a smaller concentrator lens size, which would impose higher demands on the optical transmit power, (ii) a photodetector with much larger active area but at the cost of a reduced bandwidth, (iii) an array of small area photodetectors or (iv) different optical setup to enlarge the FOV [16].

Considering the worst case scenario represented by the lowest value (-35.15 dBm) of the received optical power in Fig. 3 and the optimal straight track scenario represented by the maximum received power (-17.87 dBm) in [14], the required dynamics of the receiver is  $D = 17.28$  dB, which is easily achievable using off-the-shelf components. Once the power profile for the curved track for various radii is obtained, the signal-to-noise ratio (SNR) for all different cases of  $R = 120$  m, 240 m and 500 m will be modelled to further analyse the link performance.

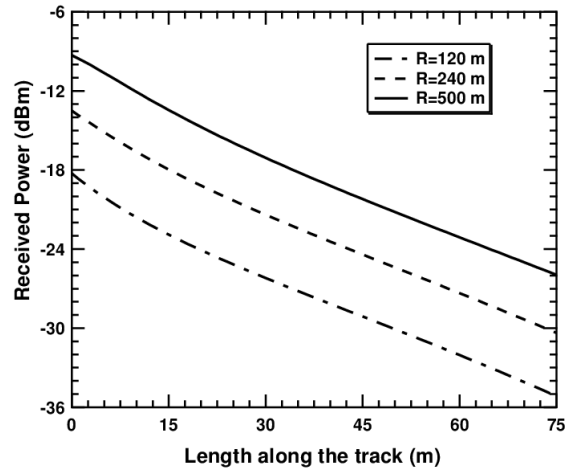

Fig. 3. Received power profile along the track for a curved track with different radius  $R$ .

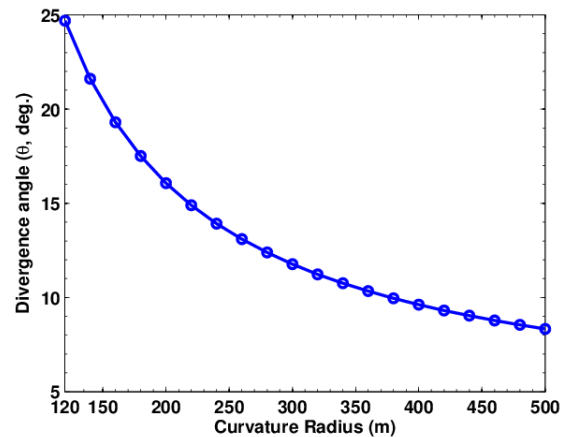

Fig. 4. Transmitter divergence angle variation according to the radius of curvature of the train track.

Since the transmitter beam divergence is dependent on the communications coverage length and the radius of curvature of the track, a graph of transmitter beam divergence against the radius of curvature is plotted as illustrated in Fig. 4. It can be inferred that as the radius of curvature increases, the required beam divergence in order to have a communications link between the transmitter and the receiver decreases. Note that the decrease in the curvature radius implies that the rail track has sharper bend. For  $R = 120$  m, the beam angle  $\theta$  is  $24.69^\circ$  as shown in Fig. 4, which is the sharpest bend in this analysis. When the curvature radius increases to 240 and 500 m, the divergence angle

required reduces to  $13.92^\circ$  and  $8.33^\circ$ , respectively. From Figs. 3 and 4, it can be inferred that for decreasing curvature radii (sharper track bend), there is increase in link loss at any point along the track. For example, considering 75 m point, for  $R = 240$  m ( $\theta = 13.92^\circ$ ) and  $R = 120$  m ( $\theta = 24.69^\circ$ ), the link loss decreases by 4.2 dB, thus illustrating the loss due to link geometry.

### 4.2 SNR and BER Performance

In our analysis of SNR and BER, data rates of 10 and 100 Mbps are used for the simulation. Although LEDs have a lower modulation bandwidth compared to lasers, data rates of 100 Mbps could be achieved for the NRZ-OOK modulation scheme using post equalisation techniques [17]. Compared to existing broadband speeds available in trains using RF, which is hardly 10 Mbps in practice, data rate of 100 Mbps shows ten-fold improvement. Higher data rates in access of Gigabits-per-second (Gbps) could be achieved using laser devices with wavelength division multiplexing.

For this system, the SNR is defined as [18]:

$$SNR = \frac{(\mathfrak{R}P_r)^2}{\sigma^2} \tag{16}$$

where  $\mathfrak{R}$  is the responsivity of the photodiode (A/W) and  $\sigma^2$  is the total noise variance, which is the combination of the shot noise and the thermal noise that are modeled as the additive white Gaussian noise (AWGN). For higher transmission rates, the optical channel can be simply modeled as a slowly varying AWGN channel [19]. From Fig. 5, it can be seen that for a curved track with a curvature radius  $R$  of 120 m, the coverage length of 75 m is achieved for  $SNR_{min}$  of 13.6 dB for a data rate of 10 Mbps. Similarly, for 100 Mbps, the coverage length along the track reduces to 50 m due to the noise bandwidth of the system. For  $R = 240$  m, the SNR at 75 m point along the track is 23.5 dB and 13.6 dB at 10 Mbps and 100 Mbps, respectively. For  $R = 500$  m, the obtained SNR values at 75 m point are 32 dB and 22 dB at 10 Mbps and 100 Mbps, respectively. Hence, it is obvious that for higher curvature radius, the achievable communications coverage length could be much higher than 75 m based on the calculated SNR values at 75 m range. This would be shown in the bit error rate (BER) analysis. For NRZ-OOK, the BER is defined as:

$$BER = Q(\sqrt{SNR}) \tag{17}$$

where  $Q(x) = \frac{1}{\sqrt{2\pi}} \int_x^\infty \exp\left(-\frac{y^2}{2}\right) dy$ , is defined as the error function.

The block diagram for analysing the BER is shown in Fig. 6. In this simulation, a binary input data stream is passed through a transmitter filter  $P(t)$  with a unit-amplitude impulse response of one bit duration  $T_b$ . The most commonly used modulation scheme, which is the NRZ OOK, is adopted in this work. The continuous time signal from the transmitter filter is then transmitted through an optical channel having an impulse response of  $h(t)$ . The noise signal  $n(t)$  is modelled as AWGN independent of  $X(t)$ . The resulting signal

is detected at the photodetector, which converts the incident optical signal into the photocurrent. The receiver filter is the maximum likelihood receiver with an impulse response  $r(t)$ , which is the matched filter (MF) followed by a sampler and a threshold detector. Following threshold detection the recovered and transmitted bit streams are compared in order to evaluate the BER performance of the system. From Fig. 7, it can be inferred that there is a very good agreement between the theoretical and simulated BER for different radii at data rates of 10 and 100 Mbps. Note that the BER performance shown in Fig. 7 for all values of  $BER \leq 10^{-6}$  is floored at the level of  $10^{-6}$ . The lowest achieved coverage length of 50 m is for  $R$  of 120 m at 100 Mbps, which is the worst case scenario in our analysis. At 10 Mbps the achieved coverage length is 70 m for the same curvature radius at a BER of  $10^{-6}$ . This value of coverage length of 70 m coincides with the higher value of  $R$  (i.e. 240 m). The coverage length increases to 100 m for the same BER for cases of  $R = 240$  m at 10 Mbps and 500 m at 100 Mbps. The maximum coverage length achieved in our simulation was 145 m for the higher curvature radius of 500 m at 10 Mbps thanks

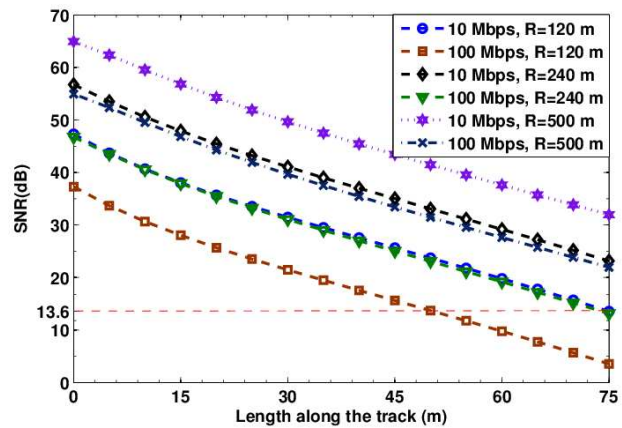

Fig. 5. SNR plot for various curvature radii of 120, 240 and 500 m at data rates of 10 Mbps and 100 Mbps.

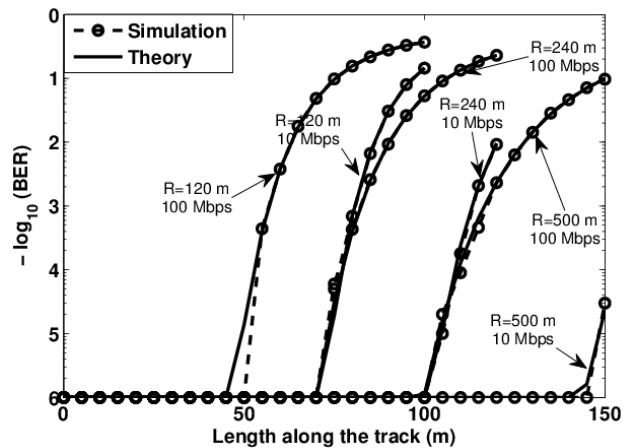

Fig. 7. BER performance for curvature radii of 120, 240 and 500 m at 10 and 100 Mbps.

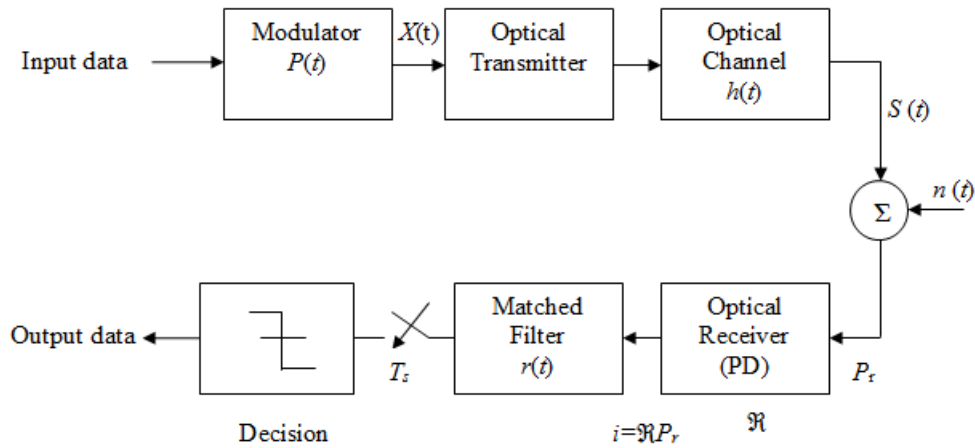

Fig. 6. Block diagram for the BER analysis for the proposed FSO G2T system.

to the high SNR value of 32 dB (see Fig. 5) for this case. For any fixed data rate, the communications coverage length achieved for acceptable communications ( $BER = 10^{-6}$ ) increases with  $R$ . Note that the increase in the communications coverage length is due to the decrease in the transmitter beam divergence with increase in  $R$  for a fixed transmitted power. Hence, for sharper bends, a higher transmitter angle is required in order to provide full coverage to the train, which would lower the communications coverage length as the transmitted power is constant.

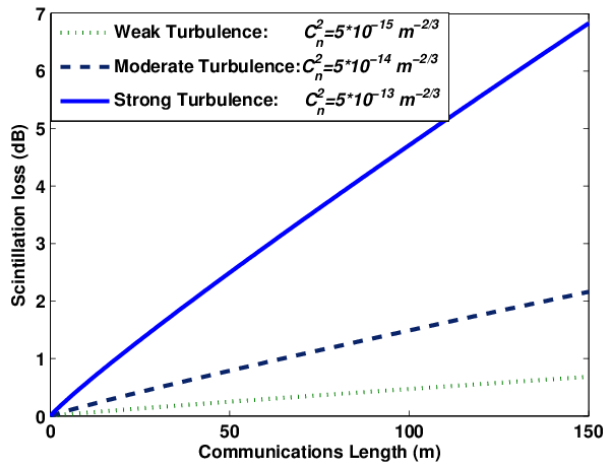

Fig. 8. Scintillation loss against the communications length for different turbulence conditions.

In order to compensate for any atmospheric attenuation and turbulence induced fluctuations in intensity (scintillation) and phase of the signal, a link budget analysis is essential. The link budget analysis for typical G2T-FSO communications is given in [19] where typically 18 dB link margin was used. Although, the scintillation effect was not considered in the link budget analysis, the loss due to the scintillation can be represented as [20, 21]:

$$A_{scint} = 2\sqrt{23.17k^7/6C_n^2L^{11/6}}[\text{dB}] \quad (18)$$

where  $k = 2\pi/\lambda$  is the wave number and  $C_n^2$  is the refractive index structure parameter. Using (18) for a moderate turbulence regime (i.e.  $C_n^2 = 5 \cdot 10^{-14} \text{ m}^{-2/3}$ ) and a maximum range  $L$  of 150 m, the scintillation loss can be calculated to be 2.1 dB whereas for the case of strong turbulence ( $C_n^2 = 5 \cdot 10^{-13} \text{ m}^{-2/3}$ ), the loss increases to 7 dB. The scintillation loss against the link length can be plotted for moderate, strong and weak turbulence conditions as shown in Fig. 8.

### 5. Conclusion

This paper has investigated the required beam divergence at the transmitter and FSO link for straight and curved rail tracks. It was shown that for the curved track, a higher beam divergence angle was required. Thus resulting in a higher optical transmit power in order to ensure FSO link availability along the train track as compared to the straight track. In order to achieve a minimum power level at the longest point along the track, the required transmit power for the curved track with  $R = 120$  m was over 2 dB higher compared to the straight track in order to ensure the link functionality. The minimum error free communications coverage length achieved was 50 m at 100 Mbps for  $R = 120$  m and 145 m at 10 Mbps for  $R = 500$  m. As the curvature radius increases, the communications coverage length could be increased for a constant power for same simulation parameters. Additionally, scintillation loss was considered for a range of turbulence regimes showing up to 7 dB loss for a link span of 150 m for the strong turbulence.

### Acknowledgements

The research is a part of the EU COST Action IC1101 and financially supported in parts by Faculty of Engineering and Environment, Northumbria University and the Czech Ministry of Education under grant

no. LD12067. The research has also been supported by the project CZ.1.07/2.3.00/20.0007 WICOMT in frame of the operational program Education for competitiveness. The described research was performed in laboratories supported by the SIX project; the registration number CZ.1.05/2.1.00/03.0072, the operational program Research and Development for Innovation. The research described in the paper was supported by the Czech Grant Agency under grants No. P102/11/1376 and by the Czech Ministry of Industry and Trade under grant agreement No. FR-TI2/705. Part of this work was presented in EuCAP 2013.

## References

- [1] ELGALA, H., MESLEH, R., HAAS, H. Indoor optical wireless communication: potential and state-of-the-art. *IEEE Communications Magazine*, 2011, vol. 49, p. 56 - 62.
- [2] DAYONG, Z., LOPRESTI, P. G., REFAI, H. H. Enlargement of beam coverage in FSO mobile network. *Journal of Lightwave Technology*, 2011, vol. 29, p. 1583 - 1589.
- [3] HENNIGER, H., WILFERT, O. An introduction to free-space optical communications. *Radioengineering*, 2010, vol. 19, no. 2, p. 203 - 212.
- [4] GHASSEMLOOY, Z., POPOOLA, W., RAJBHANDARI, S. *Optical Wireless Communications: System and Channel Modelling with MATLAB*. 1<sup>st</sup> ed. Florida (USA): CRC Press, 2013.
- [5] CVIJETIC, N., DAYOU, Q., JIANJUN, Y., YUE-KAI, H., TING, W. 100 Gb/s per-channel free-space optical transmission with coherent detection and MIMO processing. In *Proceedings of the 35<sup>th</sup> European Conference on Optical Communication*. 2009, p. 1 - 2.
- [6] LE MINH, H., O'BRIEN, D., FAULKNER, G., BOUCHET, O., WOLF, M., GROBE, L., LI, J. A 1.25-Gb/s indoor cellular optical wireless communications demonstrator. In *Proceedings of the IEEE Avionics, Fiber-Optics and Photonics Technology Conference*. 2008, p. 37 - 38.
- [7] XIAOMIN, J., XIAN, W., CHI YEH, H. Design and implementation of mobile free space optical communication system. *IEEE Photonics Technology Letters*, 2010, vol. 22, p. 1598 - 1600.
- [8] AHMADI, S., J., XIAN, W., CHI YEH, H. *Mobile WiMAX: A Systems Approach to Understanding IEEE 802.16m Radio Access Technology*. Boston: Elsevier, 2011.
- [9] YEH, C.-H., CHOW, C.-W., LIU, Y.-L., WEN, S.-K., CHEN, S.-Y., SHEU, C.-R et al. Theory and technology for standard WiMAX over fiber in high speed train systems. *Journal of Lightwave Technology* 2010, vol. 28, p. 2327 - 2336.
- [10] LANOO, B., COLLE, D., PICKAVET, M., DEMEESTER, M. Radio-over-fiber-based solution to provide broadband Internet access to train passengers [Topics in Optical Communications]. *IEEE Communications Magazine* 2007, vol. 45, no. 2, p. 56 - 62.
- [11] LUO, Q., FANG, W., WU, J., CHEN, Q. Reliable broadband wireless communication for high speed trains using baseband cloud. *EURASIP Journal on Wireless Communications and Networking*, 2012, vol. 2012, p. 1 - 12.
- [12] PAUDEL, R., GHASSEMLOOY, Z., LE MINH, H., RAJBHANDARI, S., LIVINGSTONE, B. Investigation of FSO ground-to-train communications in the laboratory environment. In *Proceedings of the 2<sup>nd</sup> Asian Himalayas International Conference on Internet*. 2011.
- [13] HARUYAMA, S., URABE, H., SHOGENJI, T., ISHIKAWA, S., HIRUTA, M., TERAOKA, F., et al. New ground-to-train high-speed free-space optical communication system with fast handover mechanism. In *Optical Fiber Communication Conference and Exposition (OFC/NFOEC) and the National Fiber Optic Engineers Conference*. 2011.
- [14] PAUDEL, R., GHASSEMLOOY, Z., LE MINH, H., RAJBHANDARI, S., LEITGEB, E. Lambertian source modelling of free space optical ground-to-train communications. In *8<sup>th</sup> International Symposium on Communication Systems, Networks and Digital Signal Processing*. Poznan (Poland), 2012.
- [15] O'BRIEN, D. C., KATZ, M., WANG, P., KALLIOJARVI, K., ARNON, S., ISRAEL, N., et al. Short-range optical wireless communications. In *Wireless World Research Forum*. 2005.
- [16] DENG, P., YUAN, X., KAVEHRAD, M., ZHAO, M., YENG, Y. Off-axis catadioptric fisheye wide field-of-view optical receiver for free space optical communications. *Optical Engineering*, 2012, vol. 51, p. 1 - 11.
- [17] LE-MINH, H., O'BRIEN, D., FAULKNER, G., ZENG, L., LEE, K., JUNG, D., et al. 100-Mb/s NRZ visible light communications using a postequalized white LED. *IEEE Photonics Technology Letters*, 2009, vol. 21, p. 1063 - 1065.
- [18] AGRAWAL, G. P. *Fiber-Optic Communication Systems*. 3<sup>rd</sup> ed. New York (USA): Wiley & Sons, 2002.
- [19] KOLKA, Z., BIOLKOVA, V., BIOLEK, D. Simulation of FSO transmission channel. In *Proceedings of the 7<sup>th</sup> WSEAS International Conference on Circuits, Systems, Electronics, Control and Signal Processing*. 2008.
- [20] PAUDEL, R., GHASSEMLOOY, Z., LE MINH, H., RAJBHANDARI, S. Modelling of free space optical link for ground-to-train communications using a Gaussian source. *IET Optoelectronics*, 2013, vol. 7, p. 1 - 8.
- [21] TSUKAMOTO, K., HASHIMOTO, A., ABURAKAWA, Y., MATSUMOTO M. The case for free space. *IEEE Microwave Magazine*, 2009, vol. 10, p. 84 - 92.
- [22] BOUCHET, O., MARQUIS, T., CHABANE, M., ALNABOULSI, M., SIZUN, H. FSO and quality of service software prediction. In *Proceedings of the SPIE*, 2008, vol. 5892, p. 28 - 39.

## About Authors...

**Rupak PAUDEL** received his Bachelor's degree in Electronics Engineering from Kathmandu Engineering College affiliated to Tribhuvan University, Kathmandu, Nepal in 2007. In 2009, he received his MSc. in Optoelectronics and Communications Engineering with distinction from Northumbria University, Newcastle upon Tyne, United Kingdom. He was also awarded Photon Fire Prize for outstanding achievement during his MSc. In 2010, he received funding from the School of Computing, Engineering and Information Sciences, Northumbria University to carry out PhD research in the field of Optical Wireless Communications (OWC). He is also a student member of IEEE.

**Juraj POLIAK** was born in 1987. He received the Ing. (M.Sc.) degree in electrical engineering in 2011 and currently is a PhD student at the Department of Radio Electronics, Brno University of Technology. His main focus is the



modelling of the laser beam behaviour along the propagation path and influence of various phenomena on its intensity profile. He is also a member of SPIE and IEEE.

**Zabih GHASSEMLOOY** CEng, Fellow of IET, Senior Member of IEEE: Received his BSc (Hons) degree in Electrical and Electronics Engineering from the Manchester Metropolitan University in 1981, and his MSc and PhD in Optical Communications from the University of Manchester Institute of Science and Technology (UMIST), in 1984 and 1987, respectively with Scholarships from the Engineering and Physical Science Research Council, UK. From 1986-87 worked in UMIST and from 1987 to 1988 was a Post-doctoral Research Fellow at the City University, London. In 1988 he joined Sheffield Hallam University as a Lecturer, becoming a Reader in 1995 and a Professor in Optical Communications in 1997. From 2004 until 2012 was an Associate Dean for Research in the School of Computing, Engineering and in 2012 he became Associate Dean for Research and Innovation in the Faculty of Engineering and Environment, at Northumbria University at Newcastle, UK. He also heads the Northumbria Communications Research Laboratories within the Faculty. In 2001 he was a recipient of the Tan Chin Tuan Fellowship in Engineering from the Nanyang Technological University in Singapore to work on the photonic technology. He is the Editor-in-Chief of the International Journal of Optics and Applications The Mediterranean Journal Electronics and Communications. He currently serves on the Editorial Committees of number international journals. He is the founder and the Chairman of the IEEE, IET International Symposium on Communication Systems, Network and Digital Signal Processing. His researches interests are on photonics switching, optical wireless and wired communications, visible light communications and mobile communications. He has supervised a large number of PhD students (more than 40) and has published over 460 papers (160 in journals + 11 book chapters) and presented several keynote and invited talks. He is a co-

author of a CRC book on "Optical Wireless Communications - Systems and Channel Modelling with Matlab (2012); a co-editor of an IET book on "Analogue Optical Fibre Communications". From 2004-06 he was the IEEE UK/IR Communications Chapter Secretary, the Vice-Chairman (2004-2008), the Chairman (2008-2011), and Chairman of the IET Northumbria Network (Oct 2011-). Personal Web site: <http://soe.northumbria.ac.uk/ocr/people/ghassemlooy/>

**Otakar WILFERT** was born in 1944. He received the Ing. (M.Sc.) degree in electrical engineering in 1971 and CSc. (Ph.D.) degree in applied physics in 1984, both from the Military Academy in Brno, Czech Republic. Currently he is a professor at the Department of Radio Electronics, Brno University of Technology. He lectures in the courses Quantum Electronics and Laser Techniques and Optoelectronics. He has investigated problems of free space optical communication under various grant projects from the Ministry of Education of the Czech Republic and the Czech Science Foundation. The main results have been published in prestigious journals and at significant conferences. Areas of his research interest include optical communications and laser radar systems. He is a member of IEEE, SPIE, European Optical Society, Czech and Slovak Photonics Society and the Official Member of Commission D (Electronics and Photonics) of URSI.

**Erich LEITGEB** was born in 1964 in Fürstenfeld (Styria, Austria) and received his master degree (Dipl.-Ing. in Electrical Engineering) at the Technical University of Graz in 1994. From 1982 to 1984 he attended training to an officer for Communications in the Austrian army, (his current military rank is Major). In 1994 he started research work in Optical Communications and RF at the Department of Communications and Wave Propagation (TU Graz). In February 1999 he received his PhD-degree (Dr. at the University of Technology Graz) with honors. He is currently Associate Professor at the University of Technology Graz.