

## ASOCSA2011-70

### Conceptual model of client health and safety (H&S) Culture

Innocent Musonda<sup>1</sup>, Theo C. Haupt<sup>2</sup>

<sup>1</sup>[innocentmusonda@gmail.com](mailto:innocentmusonda@gmail.com),

<sup>1</sup> PhD Candidate, University of Johannesburg, Johannesburg, South Africa

<sup>2</sup> Professor, University of Mississippi, United States

#### ABSTRACT

**Purpose:** This paper presents a conceptual six factor client H&S culture model referred to as the LIP+3C. The factors *leadership, involvement, procedures, commitment, communication* and *competence* were theorised to explain the client H&S culture construct. The postulated model is based on theory obtained from literature as well as from a Delphi research. H&S culture has been recognised as the feasible way to improve H&S performance in the construction industry.

**Design/methodology/approach:** A Delphi study as well as a synthesis of literature was conducted and resulted in a theorised conceptual model. To validate the model, a questionnaire survey with a response of 281 was conducted. Findings from the questionnaire survey were analysed using Structural Equation Modelling (SEM) with EQS version 6.1 software.

**Findings:** The six factor client H&S culture model was found to be well fitting to the sample data through the confirmatory factor analysis. Consequently client H&S culture findings were that client culture could be explained by the level of *leadership, involvement, procedures, commitment, communication* and *competence*.

**Research limitations/implications:** The size of the sample may affect the generalisability the findings in view of the complexity of the model.

**Practical implications:** The proposed model in this study makes it possible to determine and predict the client H&S culture. The indicator variables can be used as check items for performance measurement and thus operationalize the concept of H&S culture.

**Originality/value:** Adopting the LIP+3C culture model composed of elements that can easily be implemented and understood will contribute to improving the current H&S status

**Keywords:** Conceptual, culture, health and safety, improvement, LIP+3C, Model, performance.

#### 1. INTRODUCTION

Literature has shown that the construction industry's H&S performance leaves much to be desired (Bomel, 2001; CIDB, 2008; and McDonalds et al, 2009). As a result, the construction industry is in dire need of improvement in terms of H&S performance (ILO, 2003).

Various improvement methods have been suggested to improve H&S performance in the industry, however it seems the most feasible way to improve H&S performance in the industry is through a culture change (Riley et al 2001; Baram, 2007; Chinda, 2007). However despite a general agreement that H&S improvement may only be realised with an improvement in the H&S culture, the concept of culture and in particular H&S culture is still a confusing concept. This has resulted in a myriad of definitions and measurement methods of the concept. In addition, there is no agreement on the factors of H&S. Despite these differences on what culture is, what the factors of H&S are, and how it should be measured, there is a general agreement on the efficacy of the concept to improve H&S performance (Dingsdag et al, 2006); (Molenaar et al, 2002; Chinda et al, 2007). It is in fact suggested that clients' culture could offer an opportunity for addressing the problem of H&S performance (Bomel, 2001). It has been suggested that the impetus for change lies with the clients of construction projects because clients can influence contractors' H&S performance.

In this study therefore, a six factor client H&S culture model has been proposed and validated through structural equation modelling in order to operationalise it in the construction industry.

## 2. CONCEPTUAL MODEL

The theory behind the conceptual model presented in the next paragraph, was drawn from literature. The factors comprising the postulated model were aspects that have been said to influence H&S culture and no regard was made to the term/s used to describe them but rather focus was placed on its active description.

According to Chinda et al (2007) the aspect of leadership, Policy and strategy of an organisation, people, partnerships and resources, processes and goals are key contributors to H&S culture. In order to change culture, IOSH (2004) contend that there is need for a commitment to change and there has to be leadership at the highest management level. Although he referred to indicators and global components of H&S culture, Wiegmann (2002) identified that organisational commitment and involvement, employee empowerment, a reward system and reporting system contribute to the H&S culture. Specific aspects such as education and training have also been identified as vital aspects to obtain a H&S culture (Fitzgerald, 2005; Pellicer and Molenaar, 2007). In a recent study by Choudry et al (2009), 11 factors were identified namely commitment and involvement, procedure, psychological feature, economical feature, self-esteem, workers' experience, performance pressure, working environment, job security and education.

Apart from the above, other factors such as communication (Dingsdag et al, 2006; Gadd, 2002; Havold, 2007; Mohamed, 2002, IET, 2009 and IOSH, 2004); competence (Gadd, 2002; IET, 2009; IOSH, 2004; Mohamed, 2002), and leadership (Dingsdag, 2006; Fitzgerald, 2005; IET, 2009) have also been identified as factors contributing to H&S culture. Risk

perception of workers (Gadd, 2002; Entec 1999; and Flin, 2000) and more generally policies, procedures and rules (Flin et al, 2002; Fernández-Muñiz, 2007 and Mohamed, 2002) have also been identified as factors influencing H&S culture. Perhaps one of the most important factors that has been said to influence culture is the aspect of performance measurement. IOSH (2004), Fitzgerald (2005), Gadd (2002), and Pidgeon and O'Leary (Pidgeon, 2000) all identified this aspect of performance measurement and feedback of results as being one of the influences on H&S culture.

From the above (1) leadership (2) involvement (3) procedures (4) commitment (5) communication and (6) competence were identified to be factors of client H&S culture. These were found to be common to most studies. The H&S culture factors have been referred to as the LIP+3C model of H&S culture in this study. The diagrammatical presentation of the model is presented in figure 1.0.

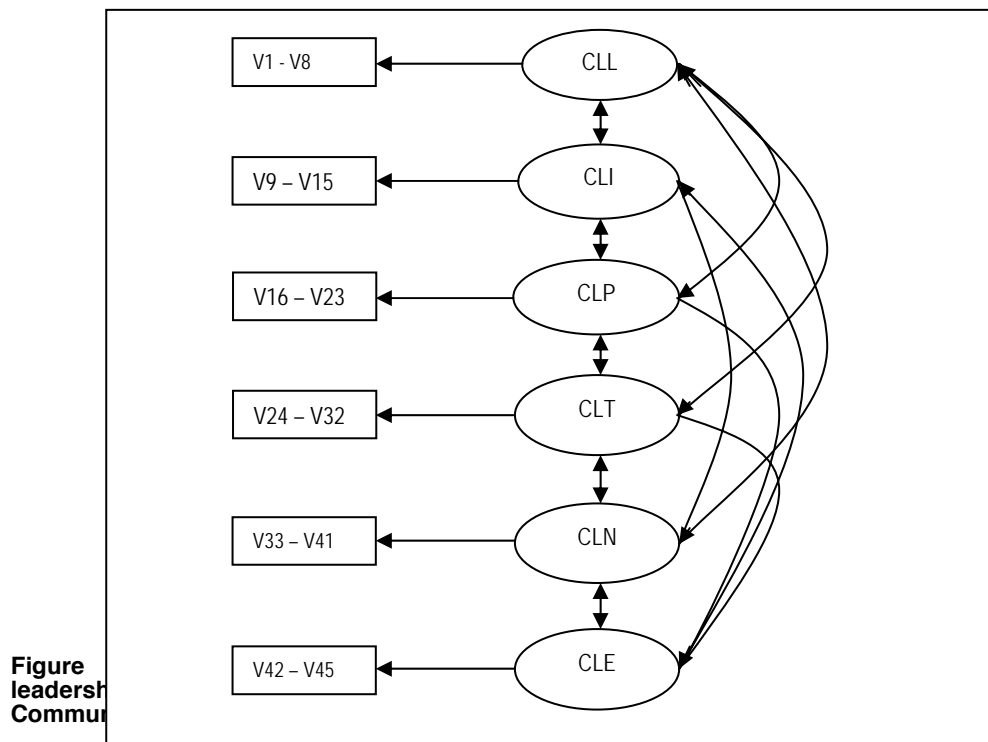

### 3. FINDINGS

A questionnaire survey was conducted on selected construction projects in South Africa and Botswana. A sample of 281 responses was realised. Analysis of results was conducted through SEM using EQS version 6.1

software. The number of cases that were analysed was 273 cases from a sample of 281 because eight cases were skipped as they had missing variables. The client H&S culture scale had 19 dependent variables, 25 independent variables and 53 free parameters. The number of fixed nonzero parameters was 25.

The hypothesis to be tested was that Client H&S culture is explained by the factors; leadership, involvement, procedures, commitment, competence and communication.

### 3.1 Residual covariance analysis

In order to establish how well the model fit the sample data and the strength of the hypothesised relations between variables, results presented on residual covariance matrix, distribution of standardised residuals, fit statistics and statistical significance at probability level of 5% were examined.

The residual covariance matrix for both un-standardised and standardised are reported. Results show that all the absolute residual values and the average off-diagonal absolute residual for both un-standardised and standardised were very much close to zero. The smallest un-standardised average off diagonal residual was 0.0076 whilst the largest was 0.0445. Similarly, the smallest standardised average off diagonal residual was 0.0068 whilst the largest was 0.0392. In order to suggest that the model describes the sample data well, the residual values should be very small and evenly distributed. Byrne (Byrne, 2006) suggests that a value can be said to be large if it is greater than 2.58. Therefore since the values in the current study presented in table 1 were all less than 2.58, they were suggestive of a good fit to the sample data. In addition, an average of 97.41% of standardised residuals fell between -0.1 and +0.1. In another analysis of the whole client H&S culture with parcels, results were that 100% of the standardised average absolute residual fell within the -0.1 and +0.1 range indicating an overall good fit.

**Table 1: Client culture average absolute residuals**

Variable	Un-standardised		Standardised		
	Ave absolute residual	Ave off-diagonal absolute residual	Ave absolute residual	Ave off-diagonal absolute residual	% falling between $-0.1$ & $+0.1$
leadership	0.0276	0.0355	0.0271	0.0349	94.44%
Commitment	0.0304	0.0380	0.0214	0.0267	97.78%
Involvement	0.0288	0.0384	0.0163	0.0217	100%
Communication	0.0329	0.0411	0.0293	0.0366	97.77%
Competence	0.0076	0.0127	0.0068	0.0113	100%
Procedures	0.0346	0.0445	0.0305	0.0392	94.45%
Overall Client culture	0.0180	0.0200	0.0177	0.0197	100%

### 3.2 Fit indexes

Despite an indication of a good fit from the residual covariance analysis, evaluation of fit indexes was necessary. A two statistic strategy of fit

indexes is reported in this study. The robust comparative/incremental index, Comparative Fit Index (CFI) and the robust absolute fit index, Root Mean Square Error of Approximation (RMSEA) at 90% confidence interval were evaluated in order to establish fit of the model and are reported in this study. In addition, the Sattora-Bentler scaled chi-square ( $S - B\chi^2$ ) and the Standard Root Mean Squared Residual (SRMR) were evaluated in order to compliment the conclusion on model fit and are also reported. Model analysis was a pure Confirmatory Factor Analysis (CFA) procedure. The findings from measurement models on *leadership*, *involvement*, *procedures*, *commitment*, *communication* and *competence* are presented first and then the full six factor structural model on client culture.

The sample data on the *leadership* factor of client culture and its associated indicator variables, yield a  $S - B\chi^2$  of 50.329 with 20 degrees of freedom. The associated p-value was determined to be 0.00020. The ratio of  $S - B\chi^2$  to the degree of freedom yield a value of 2.52 which is lower than the acceptable value of 3.0. The robust CFI index was found to be 0.955. A value greater than 0.95 for a well-fitting model is recommended (Hu and Bentler, 1999). The robust RMSEA at 90% confidence interval with the lower bound value of 0.050 and the upper bound value of 0.100 yield 0.075. In addition the SRMR yield an index of 0.041. A good fitting model is expected to have an SRMR index lower or equal to 0.05 whilst an index of 0.08 is sufficient to accept the postulated model. The absolute fit index SRMR accounts for the average discrepancy between the sample and the postulated correlation matrices and therefore it represents the average value across all standardised residuals and ranges from zero to 1.00 in a well fitting model (Byrne, 2006). Evaluation of the above fit indexes indicated an acceptable fit of the measurement model because all the estimates met the cut-off values of  $> 0.9$  for robust CFI,  $< 0.08$  for SRMR (ML),  $\leq 0.08$  for the robust RMSEA (CI 0.050:0.100). See table 2.

The sample data for the factors *involvement*, *competence* and *commitment* yield index values that suggested a good fit. The CFI index values for those factors were all greater than the 0.95 value and the SRMR indexes were less than the 0.05 recommended values for a good fit model. However, the RMSEA with the 90% confidence, yield values that are merely acceptable as they were greater than 0.05 but crucially less than the 0.08.

As for the client health and safety culture factors of *procedures* and *communication*, the models were less fitting to the sample data. Although the CFI and the SRMR indexes fell within the acceptable range, the RMSEA and the scaled  $S - B\chi^2$  indicated a rather weak fit.

The full six factor model was however found to be well fitting to the data. The  $S - B\chi^2$  was found to be 219.323 with 137 degrees of freedom (P=0.00001) yielding the chi-square- degree of freedom ratio of 1.60. The CFI was found to be 0.979 whilst the RMSEA with 90% confidence interval (lower bound value = 0.035 and upper bound value = 0.058) was found to be 0.047. The SRMR was found to be 0.025. Those fit indexes for the client H&S culture model was suggestive of a very good fit overall.

**Table 2: Robust fit indexes for client culture construct**

		$S-B\chi^2$	df	CFI	SRMR	RMSEA	RMSEA CI 90%
Variable	Cut-off index	Acceptable	0.95	0.95	0.08	0.08	
		Good		0.95	0.05	0.05	
	Leadership	50.329	20	0.955	0.041	0.075	0.050:0.100
	Involvement	30.183	14	0.986	0.024	0.064	0.032:0.096
	Procedures	103.998	20	0.934	0.045	0.123	0.100:0.147
	Competence	2.642	2	0.999	0.010	0.034	0:0.129
	Communication	133.395	27	0.940	0.042	0.119	0.099:0.139
	Commitment	64.100	27	0.966	0.031	0.071	0.049:0.093
	Overall Client culture	219.323	137	0.979	0.025	0.047	0.035:0.058

### 3.3 Significance of parameter estimates

In addition to the overall fitting of the model, the significance of individual parameters is equally important. As such, Raykov (1991) recommend further examination of factor loadings, standard errors and the test statistics in addition to overall fit statistics before conclusions could be made about the appropriateness of the postulated models. Therefore those estimates were examined and are now presented below.

According to Byrne (2006) estimates are said to be unreasonable if they have correlation values that are greater than 1.00, have negative variances and the correlation or covariances are not definite positive. Furthermore, the test statistic has to be greater than 1.96 based on the probability level of 5% before the hypothesis can be rejected (Byrne, 2006). The test statistic reported in this study is the parameter estimate divided by its standard error and therefore it functions as a Z-statistic to test that the estimate is statistically different from zero.

Inspection of the correlation values, standard errors and the test statistic in table 3, show that all correlations were not greater than 1.00, all test statistics were greater than 1.96 and the signs were appropriate. The estimates were therefore reasonable as well as statistically significant. All parameter estimates showed a high correlation values close to 1.00 suggesting a high degree of linear association between the indicator variables and the latent variables. See table 3.

The test statistic, magnitude and signs for the overall six factor client H&S culture also showed that the estimates were reasonable and statistically significant. The covariances among independent variables at 5% level also showed that they were statistically significant. The covariance factor loadings ranged from 0.653 (Involvement (F2) – Leadership (F1)) to 0.942 (Commitment (F4) - Involvement (F2)). Table 4 presents independent variable correlations, standard errors and the test statistic.

**Table 3: Coefficients and test statistics of indicator variables (Robust statistical significance at 5% level)**

Latent variable	Indicator variable  (The client...)	Coefficient	Test statistic	Significant?
Leadership	Considers H&S implications before making decisions on the project	.741	11.011	Yes
	Has an effective H&S policy	.796	13.209	Yes
	Monitors H&S on the project throughout all stages	.816	14.657	Yes
	Monitors designers' H&S implementation	.841	17.700	Yes
	Monitors contractor's H&S implementation	.792	13.641	Yes
	Mandated designers to manage project H&S	.717	11.047	Yes
	Requires that the contractor manages project H&S	.618	8.759	Yes
Commitment	Coordinates designers & contractor to ensure good H&S	.798	14.022	Yes
	Demonstrated positive attitude toward H&S	.839	10.628	Yes
	Actively promoted H&S in a consistent manner across all levels	.806	13.316	Yes
	Provided finance for H&S	.758	11.307	Yes
	Supported implementation of H&S activities	.775	12.254	Yes
	Put in efforts to ensure every aspect of work & operations are routinely evaluated for H&S	.942	17.663	Yes
	Conducted regular H&S tours on the project	.956	17.884	Yes
	Been involved in investigations of accidents, incidents & ill-health on the project	.887	15.811	Yes
Involvement	Set H&S as an important agenda item in every project progress meeting	.799	13.116	Yes
	Set H&S as a No.1 priority on the project	.957	17.347	Yes
	Is personally active in critical project H&S activities	.829	12.956	Yes
	Is always present in project H&S meetings	.919	12.653	Yes
	Contributes to H&S training	.934	17.308	Yes
	Is active in overseeing of H&S on critical operations	.934	18.362	Yes
	Has constantly stayed "in-touch" on H&S issues	.987	19.825	Yes
Communication	Always communicates information on H&S to all parties	.962	18.066	Yes
	Conducts regular audits & inspections	.954	17.972	Yes
	Has set up a formal reporting system of incidents & accidents on the project	.902	16.644	Yes
	Involved all parties in planning for H&S on the project	.865	16.419	Yes
	Involves all parties in H&S review	.820	17.241	Yes
	Has provided timely feedback on reported accidents & incidents on the project	.919	18.530	Yes
	Communicates risk findings to all parties on the project	.977	21.252	Yes
	Clearly made H&S policy statements for the project	.894	17.517	Yes
Competence	Has clearly outlined H&S roles & responsibilities for all parties on the project	.895	18.733	Yes
	Has clearly communicated expected performance on H&S to all	.890	16.611	Yes
	Has provided information on H&S risk control to all parties	.965	18.807	Yes
	Representatives have demonstrated knowledge of H&S	.785	13.082	Yes
Procedures	Conducts H&S training for its own staff	.976	20.689	Yes
	Deployed staff on the project that are qualified to manage H&S	.963	18.160	Yes
	Ensured that H&S induction to client staff was done on the project	.997	18.883	Yes
Procedures	Has programs to monitor and analyse H&S implementation	.908	19.753	Yes
	Has clear project H&S goals	.827	15.959	Yes
	Scheduled H&S as a key contract prequalification criteria for all parties	.839	16.215	Yes

	involved in the project			
	Scheduled H&S in all contracts for the parties involved in the project	.770	16.205	Yes
	Conducts regular H&S performance measurement	.945	20.996	Yes
	Has its own H&S committee	.839	13.471	Yes
	Conducts Hazard identification & risk assessment	.963	19.335	Yes
	Required that designers adequately address H&S in their designs	.698	11.397	Yes

**Table 4: Covariances among client H&S culture independent variables**

Parameter	Test statistic	Significant?
Involvement– Leadership	9.518	Yes
Procedures– Leadership	21.373	Yes
Commitment– Leadership	9.329	Yes
Communication - Leadership	29.969	Yes
Competence - Leadership	17.141	Yes
Procedures - Involvement	12.260	Yes
Commitment - Involvement	69.422	Yes
Communication - Involvement	12.672	Yes
Competence - Involvement	16.363	Yes
Commitment - Procedures	10.518	Yes
Communication - Procedures	27.668	Yes
Competence - Procedures	24.718	Yes
Communication - Commitment	10.285	Yes
Competence - Commitment	15.046	Yes
Competence - Communication	18.018	Yes

**Table 5: Client H&S culture factor correlations**

Factors	CLL	CLI	CLP	CLT	CLN	CLE
CLL	0					
CLI	0.653	0				
CLP	0.813	0.709	0			
CLT	0.691	0.942	0.682	0		
CLN	0.821	0.749	0.841	0.721	0	
CLE	0.719	0.734	0.819	0.746	0.780	0

The model was also checked against misspecification by examining results from the Lagrange Multiplier Test (LM test). In EQS, a model can be said to be misspecified if there are any misfitting parameters through a LM test (Byrne, 2006). The criterion that was used to evaluate misspecification was to identify any significant drop in the  $\chi^2$  values of parameters. Additionally, in the univariate and multivariate analysis, the probability that a parameter estimate was equal to zero should be less than 0.05 in order to be rejected. This is also an indication of misspecification. However, after inspecting



results of the LM test, the results did not reveal any significant misspecification of the model.

### 3.4 Internal reliability and validity of scores

In order to determine the internal consistency of the composite of the measurement models the Rho coefficient was relied upon more than the Cronbach's alpha coefficient because it provides a good estimate of internal consistency (Byrne, 2006). According to Kline (2005) the reliability coefficient should fall between zero and 1.00. However, values close to 1.00 are desired. The Rho coefficient of internal consistency and the Cronbach's alpha are presented below in table 6. Those values show a high level of internal consistency and thus reliability.

**Table 6: Reliability coefficients of internal consistency on client culture scale**

Factor	Reliability Coefficients	
	Cronbach's Alpha	Rho reliability coefficient
Leadership	0.918	0.919
Involvement	0.834	0.833
Procedures	0.934	0.935
Commitment	0.867	0.868
Communication	0.958	0.958
Competence	0.923	0.926
Overall client culture	0.963	0.978

## 4. DISCUSSION AND CONCLUSION

For both the measurement and the full six factor model of client H&S culture, the residual covariance estimates fell within the acceptable range, the robust fit indexes met the cut-off indexes and that all the parameter estimates were statistically significant and feasible. Therefore it can be concluded that the six factor model for client H&S culture namely the LIP+3C, fit the sample data well when analysed with the structural equation modelling in a confirmatory factor analysis. Furthermore, there was no significant evidence that indicated model misspecification and therefore the LM test supported the conclusion that the measurement and full structural model for client H&S culture scale fit well.

However, evidence of high colinearity was observed between the factors of client *commitment* and client *involvement*. The correlation between the two was found to be 0.942. A value that is higher than 0.850 is indicative of high colinearity. High colinearity may mean that respondents could not differentiate between the two concepts and viewed it as one and the same thing.

All indicator variables had strong relationships with the six factors of client H&S culture. The minimum factor coefficient was found to be 0.618 whilst the highest was found to be 0.997. However for the *leadership* factor,

monitoring designers and H&S implementation in a project had a higher bearing than all other indicator variables. The factor coefficients were determined to be 0.841 and 0.816 respectively. On the other hand, client *commitment* was said to be more predicted by whether the client has Set H&S as a No.1 priority on the project (0.957), Conducted regular H&S tours on the project (0.956) and whether they put in effort to ensure that every aspect of work and operations were routinely evaluated for H&S (0.942). As for client *involvement*, staying in touch had the highest factor coefficient at 0.987 indicating that this is the variable that explained or indicated more the aspect of client *involvement*. All the indicator variables for the *involvement* factor loaded very high with factor coefficients of more than 0.90.

Indicator variables for the *communication* factor also had high factor coefficients indicating that they significantly measured the factor. Communicating risk findings to all parties in a project and was found to have the highest factor coefficient of 0.977.

The aspects of training, induction and having an H&S qualified personnel in the establishment, effectively measured the client H&S factor of competence. Further, conducting a hazard identification and risk assessment, monitoring H&S programs and regular H&S performance measurement were considered to effectively measure the H&S procedures factor.

The conclusion on the measurement and structural models of the priori is that the indicator variables measured the factors that they were hypothesised to measure and the overall model fit the data. Therefore, the hypothesis is supported and cannot be rejected that Client health and safety culture can be explained by the factors; leadership, involvement, procedures, commitment, competence and communication.

## 5. REFERENCES

- BARAM, M., AND SCHOEBEL, M. (2007) Safety culture and behavioural change at the workplace. *Safety Science*, 45, 631–636.
- BOMEL, L. (2001) Improving health and safety in construction. Phase 1: Data collection, review and structuring. Norwich, Crown.
- BYRNE, B. M. (2006) Structural equation modelling with EQS- Basic concepts, Applications, and programming, Mahwah, New Jersey, Lawrence Erlbaum Associates, Inc.
- CHINDA, T. A. M., S. (2007) Causal relationships between enablers of construction safety culture. Fourth International conference on construction in the 21st century (CITC-IV) July 11-17, 2007. Gold Coast, Australia.
- CIDB (2008) Construction health and safety in South Africa. Pretoria, Construction Industry Development Board.
- DINGS DAG, D. P., BIGGS, H. C., SHEAHAN, V. L. AND CIPOLLA, C. J. (2006) A Construction Safety Competency Framework: Improving OH&S performance by creating and maintaining a safety culture. Brisbane, Cooperative Research Centre for Construction Innovation.
- FERNÁNDEZ-MUNIZ, B., MONTES-PEÓN, J. M., AND VÁZQUEZ-ORDÁS, C. J. (2007) Safety culture: Analysis of the causal relationships between its key dimensions. *Journal of Safety Research*, 38, 627–641.
- FITZGERALD, M. K. (2005) Safety performance improvement through culture change. *Trans IChemE*, part B, Process Safety Environmental protection, 83(B4), 324-330.

- FLIN, R., MEARNS, K., O'CONNOR, P., AND BRYDEN, R. (2000) Measuring safety climate: identifying the common features. *Safety Science*, 34, 177-192.
- GADD, S., AND COLLINS, A. M. (2002) Safety culture: A review of the literature. Sheffield, Health & Safety Laboratory.
- HAVOLD, J. I. (2007) National cultures and safety orientation: A study of seafarers working for Norwegian shipping companies. *Work & Stress*, 21, 173 -195.
- IET (2009) Safety Culture. Stevenage, IET.
- IOSH (2004a) Promoting a positive culture. Promoting a positive culture. A guide to health and safety culture. Leicestershire, UK, IOSH.
- IOSH (2004b) Promoting a positive culture - a guide to health and safety culture. Leicestershire, IOSH.
- KLINE, B. R. (2005) Principles and practice of structural equation modelling, New York, The Guilford Press.
- MOHAMED, S. (2002) Safety Climate in Construction Site Environments. *Journal of Construction Engineering and Management*, 128, 375–384.
- MOLENAAR K, B. H., CAILE S, AND SMITH R (2002) Corporate culture – A study of firms with outstanding construction safety. *professional safety*, 18-27.
- PIDGEON, N., AND O'LEARY, M. (2000) Man-made disasters: why technology and organizations (sometimes) fail. *Safety Science*, 34, 15 - 30.
- RAYKOV, T., TOMER, A., AND NESSELROADE, J. R. (1991) Reporting Structural Equation Modelling Results in Psychology and Aging: Some Proposed Guidelines. *Psychology and Aging*, 6, 499-503.
- WIEGMANN, D. A., ZHANG, H., VON THADEN, T., SHARMA, G. AND MITCHELL, A. (2002) Safety Culture: A Review. Savoy, Illinois, Aviation Research Lab Institute of Aviation.