



University of HUDDERSFIELD

University of Huddersfield Repository

Al-Nedawe, Basman, Buhafa, Adel M, Sibley, Martin J.N. and Mather, Peter

Optimum reed solomon code using with dicode pulse position modulation system

Original Citation

Al-Nedawe, Basman, Buhafa, Adel M, Sibley, Martin J.N. and Mather, Peter (2013) Optimum reed solomon code using with dicode pulse position modulation system. In: Proceedings of Computing and Engineering Annual Researchers' Conference 2013 : CEARC'13. University of Huddersfield, Huddersfield, pp. 25-30. ISBN 9781862181212

This version is available at <http://eprints.hud.ac.uk/19353/>

The University Repository is a digital collection of the research output of the University, available on Open Access. Copyright and Moral Rights for the items on this site are retained by the individual author and/or other copyright owners. Users may access full items free of charge; copies of full text items generally can be reproduced, displayed or performed and given to third parties in any format or medium for personal research or study, educational or not-for-profit purposes without prior permission or charge, provided:

- The authors, title and full bibliographic details is credited in any copy;
- A hyperlink and/or URL is included for the original metadata page; and
- The content is not changed in any way.

For more information, including our policy and submission procedure, please contact the Repository Team at: E.mailbox@hud.ac.uk.

<http://eprints.hud.ac.uk/>

OPTIMUM REED SOLOMON CODE USING WITH DICODE PULSE POSITION MODULATION SYSTEM

Basman M. Al-Nedawe, Adel M. Buhafa, Martin J. N. Sibley, and Peter J. Mather
University of Huddersfield, Queensgate, Huddersfield HD1 3DH, UK

ABSTRACT

Dicode Pulse Position Modulation (DiPPM) has been proposed as a more advantageous format than digital PPM with one of its main advantages being that the line rate is twice that of the original data rate, a significant reduction in speed compared to digital PPM. This paper describes the performance of a DiPPM system using a Reed Solomon (RS) code to enhance the sensitivity. Theoretical results are presented at an original data rate of 1Gbit/s, in terms of transmission efficiency, bandwidth expansion, and number of photons per pulse. According to simulation results the Reed Solomon error correction coded system offers an improvement over uncoded DiPPM of 5.12dB, when operating at the optimum code rate of approximately 3/4 and a codeword length of 2^5 symbols.

Keywords: Pulse Position Modulation, Dicode Pulse Position Modulation, Optical Fibre Communication, Error Correction Code, Reed Solomon Code.

INTRODUCTION

Since the 1980's there have been a large number of studies investigating the Pulse Position Modulation (PPM) format and its development for use in optical fibre communication systems. The performance of the digital PPM system using direct detection and coherent detection PIN-FET transimpedance amplifiers in fibre optic receivers for Gaussian received pulse shape was described by Dolinar [1] and Garrett [2]. They found that the PIN-FET PPM receiver gave a sensitivity of 10 to 12 dB more than that of the original non-return-to-zero, NRZ, on-off keying, OOK, data stream. In 1988, the practical performance of digital PPM over optical fibre was presented by Calvert, Sibley and Unwin [3]. It was demonstrated that the digital PPM system employing an optimised PIN-BJT receiver achieved sensitivity greater than equivalent NRZ OOK one by four dB.

Although most studies refer to the advantages of PPM, it comes at the cost of a large bandwidth expansion and a complicated implementation [4]. This led Sibley to formulate a new coding scheme, called Dicode PPM (DiPPM) [5]. The basic scheme idea is data changes from logic zero to logic one are coded as a SET (*S*) pulse in the DiPPM frame and transitions from logic one to logic zero are coded as a RESET (*R*) pulse. A zero signal is transmitted when the data is unvarying. The final line rate of the DiPPM is twice that of the original data, a considerable reduction in speed. The scheme is also more sensitive than the equivalent NRZ, OOK scheme [5].

McEliece investigated the use of RS optical communications [6-7]. He argued that no significant improvement could be expected merely by altering the code's rate. On the other side McEliece showed that pulse position modulation plus the Reed Solomon code yielded a practical improvement result. The comparison between uncoded and coded PPM systems for direct and heterodyne detection was discussed by Atkin and Fung [8]. They claimed that the system performance improved only for codes that were capable of reducing the minimum required number of photons adequately to compensate for the decrease in system efficiency resulting from coding. The use of RS error correction codes for optical fibre PPM channel was studied by Cryan and Unwin in 1990 [9]. They showed that the RS coded n-ary PPM system offered an improvement in transmission efficiency of typically 4.1 dB over uncoded system and 11.8 dB over heterodyne ASK PCM system. After one year Cryan and Unwin analysed the performance and optimisation for both uncoded homodyne digital PPM and digital PPM employing RS error correction code [10]. They found that digital PPM employing RS code out-performed uncoded digital PPM and achieved an improvement of 4 dB, when operating at the optimum $\frac{3}{4}$ code rate.

In this paper, the error correction code (Reed Solomon Code) with DiPPM has been used to eliminate the error sources. The slop detection and central detection methods have been used to find the results. The optimum parameters of Reed Solomon Code have been found.

FORWARD ERROR CORRECTION SYSTEM MODEL

The slop detection, and central detection methods are used to find the optimum parameters of a RS code with a DiPPM system. First of all a model of that system should be developed, to start with

simulation. A system model attempts to simulate some characteristics of a system. The model matches up the forward error correction (FEC) communication scheme, which is dependent on a RS error-control code, and shown in fig 1. The performance of each block of the model is described in Mathcad software.

SYSTEM ANALYSIS

Figure 2 shows the PCM code symbolised by the DiPPM signal using different normalised bandwidth. In DiPPM, the shape of the S and R pulses will depend on the transmitted pattern. The new pulse shapes must be found using a general DiPPM sequence $SxNRyNS$. The general form of the total DiPPM binary error probability $\{P_{eb}\}$ can be computed from the summation of the equivalent PCM probability of errors for DiPPM error sources that consider a complete sequence for all x and y :

$$P_{eb} = P_{es} + P_{er} + P_{efR} + P_{efN} \quad (1)$$

Where $\{P_{es}\}$ is the equivalent PCM error probability due to wrong-slot errors, which is equal:

$$P_{es} = 3 \left[\sum_{x=0}^{n-1} \left(\frac{1}{2}\right)^2 P_s(x+1) + \left(\frac{1}{2}\right)^{n+2} P_s(n+1) \right] \quad (2)$$

The PCM error probability for erasures $\{P_{er}\}$ is:

$$P_{er} = 2 \left[\sum_{x=0}^{n-1} \left(\frac{1}{2}\right)^2 P_r(x+1) + \left(\frac{1}{2}\right)^{n+2} P_r(n+1) \right] \quad (3)$$

The probability of a false alarm error is dependent upon inter-symbol interference. In the case that the pulse appears in the slot R the PCM error probability is:

$$P_{efR} = \left[\sum_{x=0}^{n-1} \left(\frac{1}{2}\right)^{x+3} P_f x + \left(\frac{1}{2}\right)^{n+2} P_f n \right] + \left[\sum_{x=0}^{n-1} \left(\frac{1}{2}\right)^{x+3} P_f (x+1) + \left(\frac{1}{2}\right)^{n+2} P_f (n+1) \right] \quad (4)$$

When the pulse appears in slot S , this will not affect the decoder detection. False alarm error may occur between S and R pulses where there is no InterSymbol Interference (ISI). Hence, the number of PCM decoding errors will depend on the symbol position, k , where the false alarm error appears within the run of N -symbols. Thus, the equivalent PCM error probability [11]:

$$P_{efN} = \sum_{x=1}^{n-1} \left(\frac{1}{2}\right)^{x+3} \sum_{k=1}^x (x+1-k) P_f + \left(\frac{1}{2}\right)^{n+2} \sum_{k=1}^n (n+1-k) P_f + \sum_{x=2}^{n-1} \left(\frac{1}{2}\right)^{x+3} \sum_{k=2}^x (x+1-k) P_f + \left(\frac{1}{2}\right)^{n+2} \sum_{k=2}^n (n+1-k) P_f \quad (5)$$

Error performance is improved generally when RS encoding is used over the PPM optical system. The RS decoder has the ability to correct any t error without looking to the type of defect suffered by the symbol. A RS code is specified as RS (n, k) with m -bit symbols. The block length contains n symbols; each symbol consists of m bits. In other words, the RS encoder combines k symbols data with parity symbols (redundancy) $2t$ to produce an n symbols codeword [12]. The RS decoded symbol-error probability, P_E , in terms of channel symbol-error probability, p (uncoded symbol-error probability), can be written as follows [12]:

$$P_E \approx \frac{1}{2^m - 1} \sum_{j=t+1}^{2^m-1} j \binom{2^m-1}{j} p^j (1-p)^{2^m-1-j} \quad (6)$$

Where t is the symbol-error correcting capability of the code, and the symbols are made up of m bits each. The decoded symbol error probability is linked to the binary error probability, P_{eb} , by

$$P_{eb} = \frac{2^{M-1}}{2^M - 1} P_E \quad (7)$$

SLOP DETECTION METHOD

A fixed bandwidth, 1 GHz, PIN-bipolar (PIN-BJT) transimpedance optical receiver was considered in the DiPPM receiver with noise spectral density of $24 \times 10^{-24} \text{ A}^2/\text{Hz}$. An operating wavelength of 1.55 μm and a photodiode quantum efficiency of 100% were taken and simulations were carried out using an original NRZ OOK data rate of 1 Gbit/s with line coding that resulted in $n=10$. Gaussian shape received pulses were assumed corresponding to a link bandwidth of 1.8 GHz. A threshold variable v was defined as:

$$v = \frac{v_d}{v_{pk}} \quad (8)$$

$\{v_d\}$ is the threshold crossing voltage and $\{v_{pk}\}$ is the peak voltage of the signal. The total equivalent PCM error probability is obtained first by adding together the individual probabilities of DiPPM, which should be the same as for a PCM system taken as 1 error in 10^9 pulses. Then (6) and (7) are used to compute the probability of error for the coded system with different code rate and code length. The decision time, t_d , can be determined and the number of photons per bit, b , found.

The transmission efficiency $\{\rho\}$ for the uncoded and coded DiPPM, can be written as in equations (9) and (10) respectively. Equation (9) shows the transmission efficiency for uncoded DiPPM, where b is the number of photons while equation (10) shows the transmission efficiency for DiPPM when a RS code is applied. It can be seen from equation (10) that applying an RS code reduces the transmission efficiency of the system by the code rate r . However, at the optimum code rate, the application of a RS code reduces the number of photons to achieve an overall improvement in transmission efficiency. The bandwidth expansion for coded DiPPM can calculate using equation (11).

$$\rho = \frac{\ln 2}{b} \quad \left(\frac{\text{nats}}{\text{photon}} \right) \quad (9)$$

$$\rho = r \frac{\ln 2}{b} \quad \left(\frac{\text{nats}}{\text{photon}} \right) \quad (10)$$

$$\text{Coded DiPPM bandwidth expansion} = \frac{n}{k} \times \text{bandwidth expansion for DiPPM} \quad (11)$$

CENTRAL DETECTION METHOD

The model is based on that suggested by Sibley [12]. A block diagram of the receiver system is shown in fig. 3. The simulation used an optical receiver with a limited bandwidth, ω_c , and a white-noise spectrum at its output. A classical matched filter was used as the predetection filter because the receiver had a white-noise spectrum. Transmission of dicode PPM through graded-index POF was considered and the signal presented to the threshold detector was [12].

$$v_o(t) = b\eta q R_T \frac{\omega_c}{2} \exp(\alpha^2 \omega^2) \times \exp(-\omega_c t) \text{erfc}[\alpha \omega_c - (\frac{t}{2\alpha})] \quad (12)$$

where b is the number of photons per pulse, η is the quantum efficiency of the detector, q is the electronic charge, R_T is the mid-band transimpedance of the receiver, and α is the variance of the received Gaussian pulse. This is linked to the fibre bandwidth by [12].

$$\alpha = \frac{0.1874 T_b}{f_n} \quad (13)$$

where T_b is the PCM bit-time and f_n is the fibre bandwidth normalised to the PCM data rate. The noise appearing on this signal is given by [12]

$$\langle n_o^2 \rangle = S_o \frac{\omega_c}{2} R_T^2 \exp(\alpha^2 \omega_c^2) \text{erfc}(\alpha \omega_c) \quad (14)$$

where S_o is the double-sided, equivalent input-noise current spectral density of the preamplifier. A PIN photodiode was used so that its shot noise could be neglected. The time at which the autocorrelation function of the noise at the output of the filter becomes small has been taken to be α , thus $T_R = \alpha$. The threshold level, v , was used as a system variable defined by equation (14), where v_{pk} is the peak voltage of an isolated pulse. For a given fibre bandwidth, the pulse shape and noise can be determined, and the optimum value of v that produces the lowest number of photons per pulse, b , can be found for a specified PCM error rate (1 in 10^9 in the simulations). A 1 Gbit/s PCM data-rate system, operating at a wave-length of 650 nm and a photodiode quantum efficiency of 100%, was considered. The preamplifier had a bandwidth of 10 GHz and white noise of $50 \times 10^{-24} \text{ A}^2/\text{Hz}$ when referred to the input. These parameters were obtained from a commercial device. Line-coded PCM data was used so that $n=10$. Simulations were conducted on DiPPM systems operating with and without RS code.

RESULTS

It can be clearly seen from figures 4, and 5 that a code length of 2^5 gives the minimum number of photons at different normalised bandwidth. Figures 6 and 7 show the number of photons for the DiPPM coded system when it codes different code rates, and normalised bandwidth using slop, and central detection methods. The data presented uses the optimum code word length 2^5 to compute the number of photons. We note that the number of photons increases with the increase in RS code rates. This is because the number of data symbols is directly proportional to the RS code rates.

Moreover, the results show that the number of photons is directly proportional to the normalised bandwidth when the slope detection method is used. This is because the slope detection method depends on the received signal shape.

Figures 8, and 9 clearly show that there is an optimum code rate of approximately $3/4$, which achieve maximum transmission efficiency. When the DiPPM coded system is operating below this optimum, the number of redundant symbols increases and, as predicted by equation (10), performance is degraded. Above the optimum coding rate, the number of redundant symbols is decreased which means the number of correcting symbols is also decreased and this reduces the transmission efficiency.

Figure 10 shows the numbers of photons per pulse for DiPPM systems when operating with and without RS code. Figure 11 illustrates that the transmission efficiency of DiPPM coded systems outperform the DiPPM uncoded system. Figure 12 shows the relation of the probability of error for wrong slot, erasure, and false alarm error probability. Wrong slot error is the dominant error in low bandwidth, and when the probability of wrong slot error is reducing the other two probabilities are increased to maintain the system performance by reducing the pulse energy. For this reason, we see an improvement in the transmission efficiency as the fibre bandwidth increases. This improvement continues until the wrong slot error probability is negligible. In the slope detection method the improvement lasts until 1.8 normalised bandwidth and then the transmission efficiency starts to decrease, while in the central detection method the improvement continues with increasing bandwidth.

CONCLUSIONS

This paper has examined the use of Reed Solomon (RS) codes with Dicode Pulse Position Modulation (DiPPM) in terms of transmission efficiency, bandwidth expansion and number of photons required per pulse. The slope detection and central detection methods have been used to detect the received signal. It has been shown that the use of RS codes can greatly increase the transmission efficiency of DiPPM by reducing the number of photons. Simulation results have shown that the DiPPM coded system offers a 5.12dB improvement over the uncoded system when it operates at the optimum code rate of $(3/4)$ and code length of (2^5) .

ACKNOWLEDGMENT

The first author gratefully acknowledge a studentship funded by the Department of Electrical at the Technical Institute of Baquba, Iraq.

REFERENCES

1. Dolinar, S.: A near optimum receiver structure for the detection of M-ary optical PPM signals. Int. Found. Telemetry Conf, San Diego, 145--243 (1982).
2. Garrett, I.: Digital pulse position modulation for transmission over optical fiber channels with direct and heterodyne detection. IEEE Trans. Comm., vol. com31, pp. 518--527 (1983).
3. Calvert, M. N., Sibley, M. J., Unwin R. T.: Experimental optical fibre digital pulse position modulation system. Electronics Letters, vol. 24, pp. 129--131 (1988).
4. Sibley, M. J.: Design implications of high speed digital ppm. SPIE Conference Proceedings, vol. 2024, pp. 342--352 (1993).
5. Sibley, M. J.: Dicode pulse position modulation – a novel coding scheme for optical fibre communication. IEE Proc., Optoelectron., vol. 150, no. 2, pp. 125--131 (2003).
6. McEliece, R. J.: Coding for photon channels. IEEE Proc. National Telecomm. Conf., pp.23.3.1--23.3.3 (1979).
7. McEliece, R. J.: Practical codes for photon communications. IEEE Trans. Inform. Theory., vol.IT-27, pp.393--398 (1981).
8. Atkin, G. E., Fung, K. S.: Performance analysis of coded optical PPM system using direct and coherent detection. IEEE Proc. J., pp.226--232 (1990).
9. Cryan, R. A., Unwin, R. T.: Reed-Soloman coded optical fibre digital PPM: approaching fundamental limits. IEEE International Conference on Communication Systems, Singapore, vol.1 (1990).
10. Cryan, R. A., Unwin, R. T.: Reed-Solomon coded homodyne digital pulse position modulation. IEE PROCEEDINGS -I, vol.139, no.2, pp.140--146 (1992).
11. Sibley, M. J.: Performance analysis of a dicode PPM system, operating over plastic optical fibre, using maximum likelihood sequence detection. IEE Proc.-Optoelectron., vol. 152, No. 6, pp. 337--343 (2005).
12. Bernard Sklar.: Digital Communications: Fundamentals and Applications. Second Edition, Prentice-Hall ((2001).

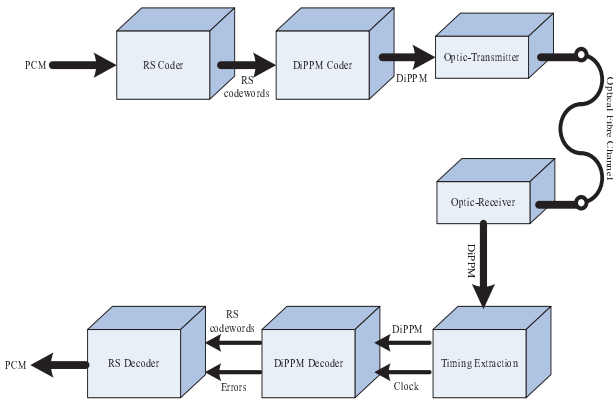

Fig. 1. Block diagram of forward error correction model

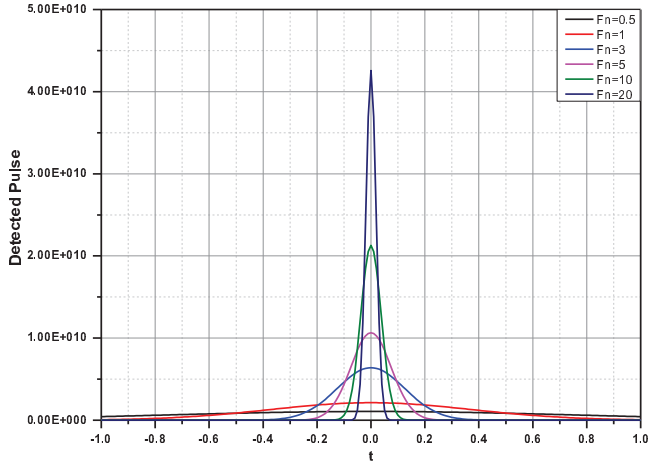

Fig. 2. The received DiPPM signal

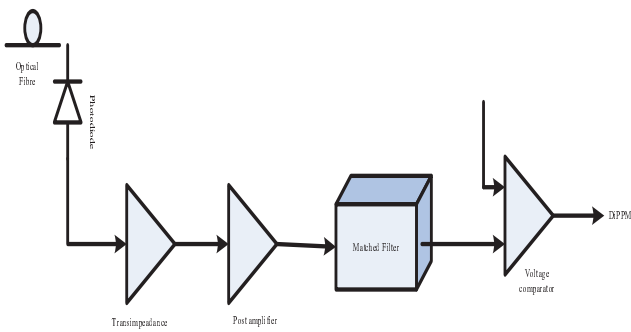

Fig. 3. Block diagram of DiPPM receiver system

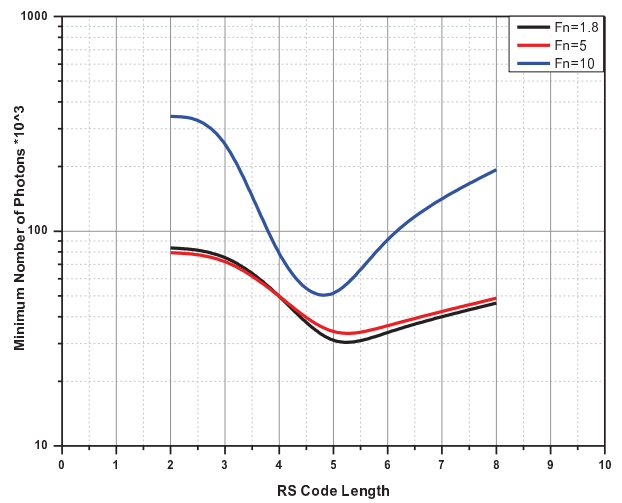

Fig. 4. Number of photons for coded DiPPM system at different RS codeword length using slop detection method

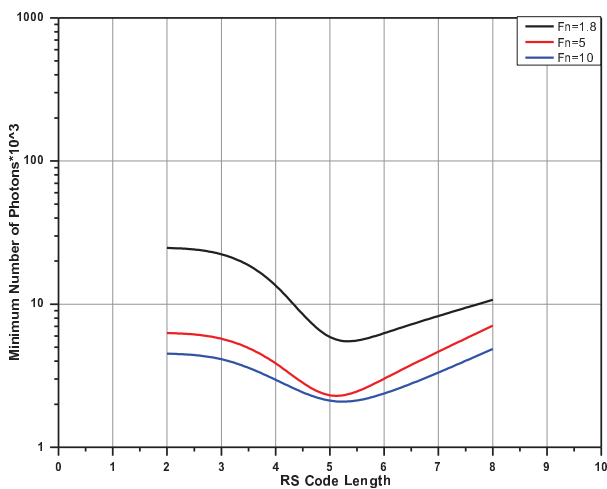

Fig. 5. Number of photons for coded DiPPM system at different RS codeword length using central detection method

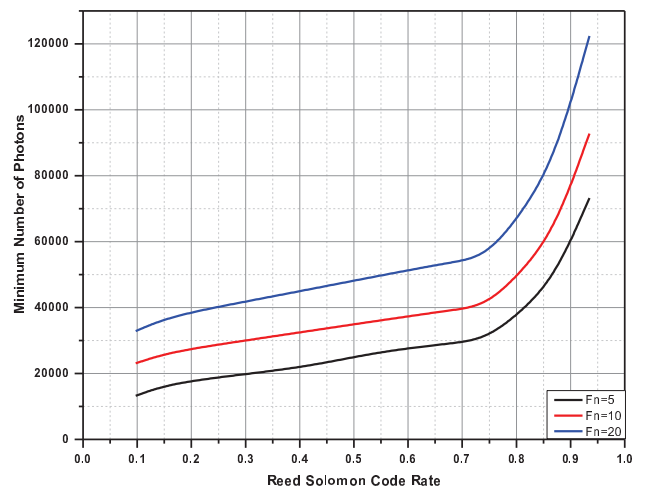

Fig. 6. Minimum Number of Photons for DiPPM System Employing RS at different Code Rates and codeword length (2^5) Using Slop Detection Method

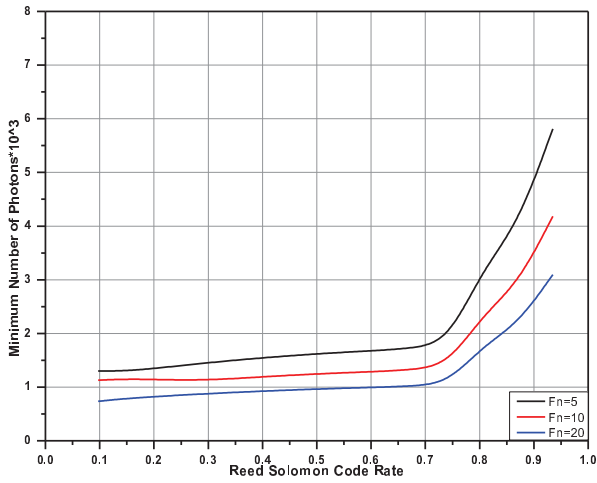

Fig. 7. Minimum Number of Photons for DiPPM System Employing RS at different Code Rates and codeword length (2^5) using the central detection method

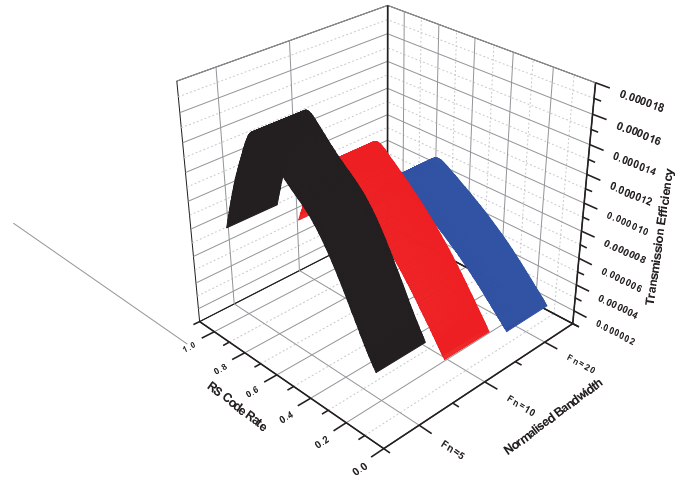

Fig. 8. The transmission efficiency for coded DiPPM system at different RS code rates using the slop detection method

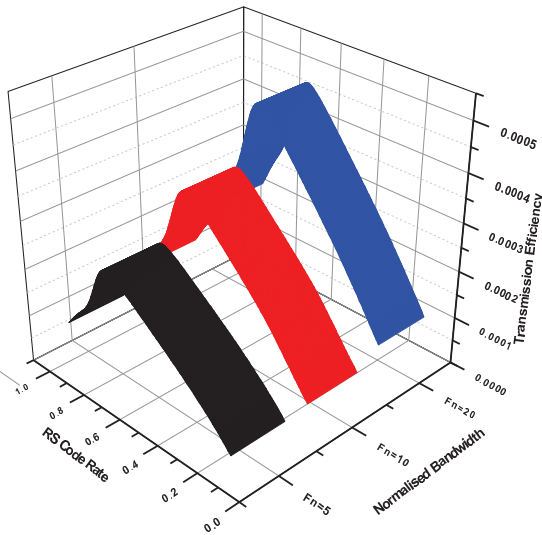

Fig. 9. The transmission efficiency for coded DiPPM system at different RS code rates using the central detection method

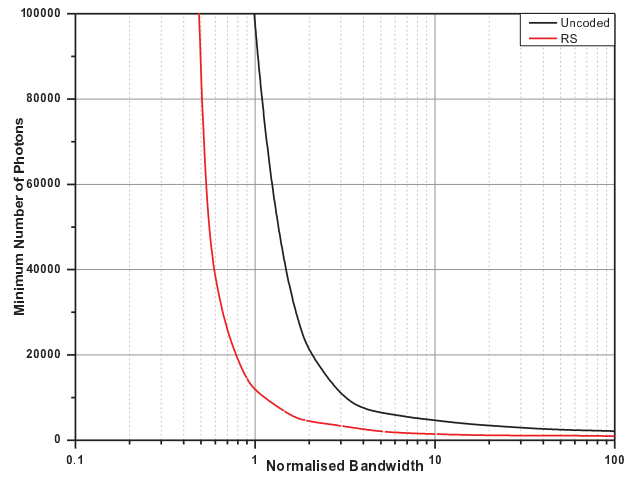

Fig. 10. Numbers of photons per pulse as a function of normalised bandwidth for DiPPM System with and without RS code using central detection method

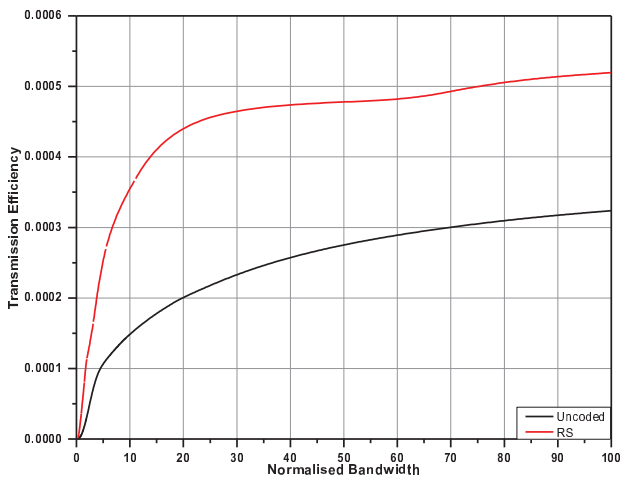

Fig. 11. The transmission efficiency as a function of normalised bandwidth for DiPPM System with and without RS code using central detection method

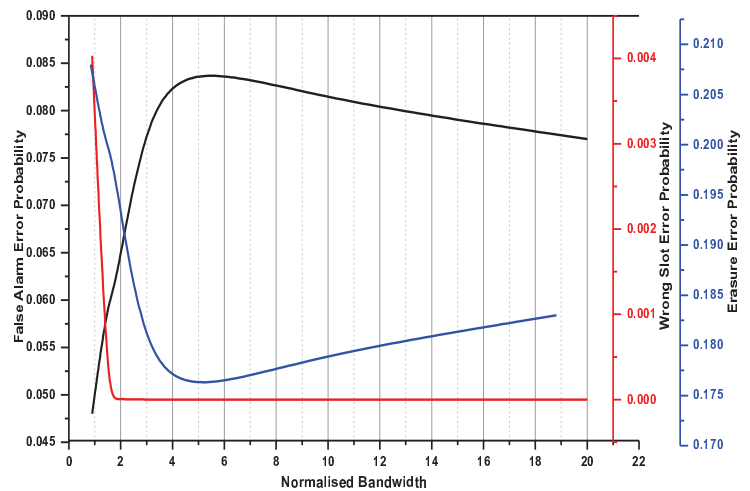

Fig. 12. Erasure, False Alarm, and Wrong Slot Error Probabilities of the coded DiPPM system