

Two-stage of Nanocones Formation by Laser Radiation on the Surface of Semiconductors

A. Medvid^{1,2,*}, P. Onufrijevs¹, G. Mozolevskis¹, E. Dauksta¹¹ Riga Technical University, 14, Azenes str., Riga, LV-1048, Latvia² Institute of Semiconductor Physics, NAS of Ukraine, Kyiv, Ukraine

(Received 12 July 2012; published online 30 August 2012)

In this work we study mechanism of nanocones formation on a surface of elementary semiconductors by Nd:YAG laser radiation. A new mechanism of p-n junction formation by laser radiation in the elementary semiconductor as a first stage of nanocones formation is proposed. We explain this effect in following way: p-n junction is formed by generation and redistribution of intrinsic point defects in temperature gradient field – the Thermogradient effect, which is caused by strongly absorbed laser radiation. According to the Thermogradient effect, interstitial atoms drift towards the irradiated surface, but vacancies drift to the opposite direction – in the bulk of semiconductor. Since interstitials in Ge crystal are of n-type and vacancies are known to be of p-type, a n-p junction is formed. The mechanism is confirmed by appearance of diode-like current-voltage characteristics after i-Ge irradiation crystal by laser radiation. The second stage of nanocones formation is laser heating up of top layer enriched by interstitial atoms with its further plastic deformation due to compressive stress caused by concentration of interstitials in the top layer and vacancies in the buried layer.

Keywords: Laser radiation, p-n junction, Nanocones, Thermogradient effect.

PACS numbers: 81.15.Fg, 79.20.Ds

1. INTRODUCTION

Nanostructures are the most investigated object in solid state physics, especially Quantum confinement effect in quantum dots [1], quantum wires [2] and quantum wells [3]. Moreover, different shape of nanostructures can lead to unique physical properties of material [4]. For example, nanocones, depending on a height of structure and solid angle α at top of it, can be quantum dots, quantum wires or quantum wells [5][6]. The decrease of nanocone's solid angle $\alpha < 60^\circ$ leads to fundamental changes of its properties. Quantum dot transforms into a quantum wire with gradually decreasing diameter from the base till the tip of the cone. This is a unique system which has wide technical applications, for example, 1D-graded bandgap structure in elementary semiconductor is a photodetector with "bolometric" or selective type of photosensitivity, depending on irradiation side [7].

Our previous investigations have shown possibility to form cone-like nanostructures on a surface of elementary semiconductors – Ge [8], Si [9] and solid solutions SiGe [10] and CdZnTe [11]. According to our investigation nanocones formation mechanism is characterised by two stages for SiGe and CdZnTe solid solutions [6]. The first stage is characterized by formation of heterostructure, for example, Ge/Si from SiGe or CdTe/CdZnTe from CdZnTe solid solutions and the second stage is characterized by formation of nanocones due to mechanical plastic deformation of the compressed Ge layer on Si or CdTe on CdZnTe respectively.

The mechanism of nanocones formation for elementary semiconductors is not clear until now. Therefore, the main goal of our investigations is to study the stages of nanocones formation in elementary semiconductors.

2. MATERIALS AND METHODS

In experiments i-Ge single crystals with resistivity $\rho = 45 \text{ } \Omega\text{cm}$; $N_a = 7.4 \times 10^{11} \text{ cm}^{-3}$, $N_d = 6.8 \times 10^{11} \text{ cm}^{-3}$,

where N_A and N_D are acceptors' and donors' concentration, and samples size $16.0 \times 3.0 \times 2.0 \text{ mm}^3$ were used. The samples were mechanically polished with diamond grease and chemically etched with H_2O_2 and CP-4 ($\text{HF}:\text{HNO}_3:\text{CH}_3\text{COOH}$ in volume ratio 3:5:3). Commercial p- and n-type single crystal silicon substrates were investigated in the experiments as well. Different intensities and wavelengths of nanosecond Nd:YAG laser were used to irradiate the samples (pulse repetition rate 12.5 Hz, power $P = 1.0 \text{ MW}$). The laser beam to the irradiated surface of the samples was directed normally. The diameter of the spot of the laser beam was 3 mm and point-to-point method was used for irradiation of the samples. All experiments of nanocones formation were performed in ambient atmosphere at pressure of 1 atm, $T = 20^\circ\text{C}$, and 60% humidity.

Current-voltage (I-V) characteristics were measured for the non-irradiated and irradiated samples. Measurements of I-V characteristics were performed by soldering 99% tin and 1% antimony alloy contacts directly on the irradiated surface of Ge and tin contacts on the opposite side (see Fig.1.). Measurements of I-V characteristics were done at room temperature and atmospheric pressure. Rectification ratio (RR) of I-V characteristics was used for characterization of p-n junction.

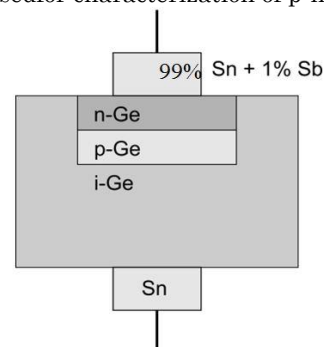

Fig. 1 – Schematic illustration of irradiated i-Ge sample with p-n junction and soldered contacts

* medvids@latnet.lv

3. RESULTS AND DISCUSSIONS

I-V characteristics of i-Ge samples before and after irradiation by Nd:YAG laser with energy of LR quantum - 4.64 eV and different intensities, are shown in Fig. 2. The I-V characteristic of the non-irradiated sample is linear. After irradiation by the laser I-V characteristics becomes diode like. This process takes place on threshold manner - resistance of the sample increases by 10 times and rectification effect appears at certain intensity of the laser radiation. Threshold intensity (I_{th}) decreases with increase of energy of LR quantum as seen in Fig.3. I_{th} are observed at the fundamental frequency $I_{th1} = 5.5$ MW/cm², the second harmonic $I_{th2} = 1.5$ MW/cm² and the fourth harmonic $I_{th4} = 1.15$ MW/cm².

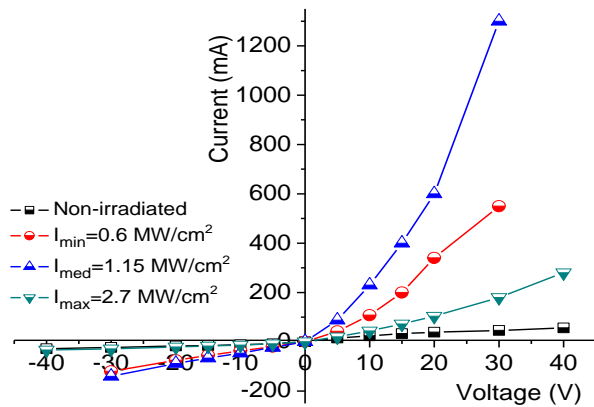

Fig. 2 – Current-voltage characteristics of a non-irradiated and an irradiated i-Ge sample by Nd:YAG laser with different intensities at $\lambda = 266$ nm and 350 laser pulses.

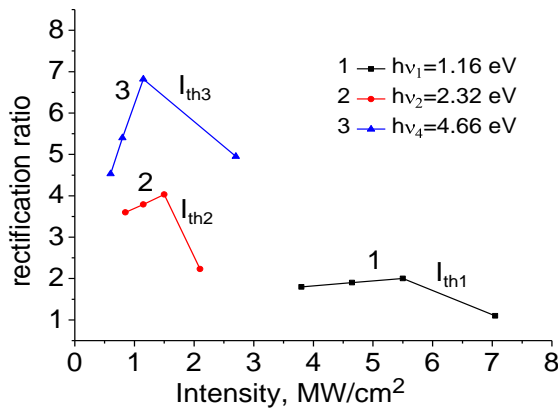

Fig. 3 – Rectification ratio as a function of intensity of Nd:YAG laser radiation for different wavelengths (energy quanta) of the laser radiation and 350 laser pulses

I-V characteristics of samples irradiated with energies of LR quanta 1.16 eV and 2.32 eV are similar to I-V characteristics in Fig. 2. Decrease of the I_{th} with increase of energy of LR quantum and appearance of I-V characteristics rectification effect we explain in the following way: irradiation of the sample by strongly absorbed LR leads to transformation of the light energy to the thermal one. Heating up the sample by LR increases additional generation of intrinsic defects in crystal - interstitials and vacancies which are quenched in crystal lattice after the end of the laser pulse. The formation of a potential barrier takes place due to separation of vacancies and interstitials in temperature gradient field [12].

Decrease of the I_{th} of LR with increase of LR quan-

tum, as can be seen in Fig.3, is an evidence of this suggestion. Concentration of interstitials at the irradiated surface and vacancies in the buried layer of the sample leads to formation of n-p junction because interstitials are donors and vacancies are acceptors in Ge [13]. Non-monotonous dependence of RR as function of the LR intensity and decrease of RR at irradiation of the samples by the second and fourth harmonics are explained by formation of nanocones (see Fig. 4) on the irradiated surfaces of the samples [6] and therefore a partial destruction n-type layer on the irradiated surface of the samples.

4. MODEL

A new mechanism of p-n junction formation by laser radiation in the elementary semiconductor as a first stage of nanocones formation is proposed. We explain this effect by following way (see Fig. 5): p-n junction is formed by generation and redistribution of intrinsic point defects in temperature gradient field – the Thermogradient effect, which is caused by strongly absorbed laser radiation. According to the Thermogradient effect, interstitial atoms drift towards the irradiated surface, but vacancies drift to the opposite direction – in the bulk of semiconductor. Since interstitials in Ge crystal are of n-type and vacancies are known to be of p-type, a n-p junction is formed (see Fig.5 a-c). The mechanism is confirmed by appearance of diode-like current-voltage characteristics after i-Ge irradiation crystal by laser radiation.. The second stage of nanocones formation is heating up of top layer by laser enriched by interstitial atoms with its further plastic deformation due to compressive stress caused by interstitials in the top layer and vacancies in the buried layer (see Fig.5 d-f).

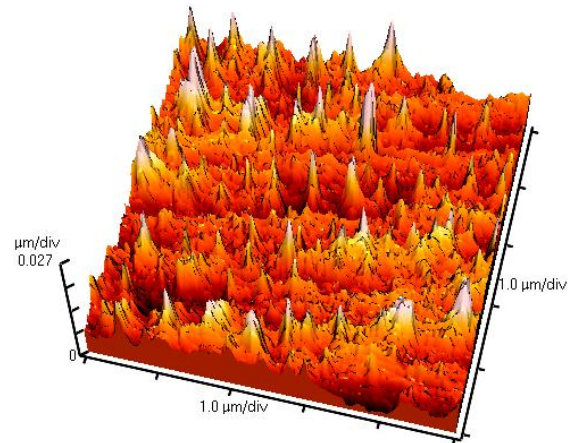

Fig. 4 – 3D AFM image of Ge surface irradiated by Nd:YAG laser at intensity 7.0 MW/cm²

5. CONCLUSIONS

For the first time a new mechanism of p-n junction formation in the elementary intrinsic semiconductor by laser radiation as the first stage of nanocones formation is proposed. P-n junction is formed by generation and redistribution of intrinsic point defects in temperature gradient field – the Thermogradient effect, which is caused by strongly absorbed laser radiation. The second stage of nanocones formation is laser heating up of top layer enriched by interstitial atoms with its further plastic deformation due to compressive stress caused by interstitials in the top layer and vacancies in the buried layer.

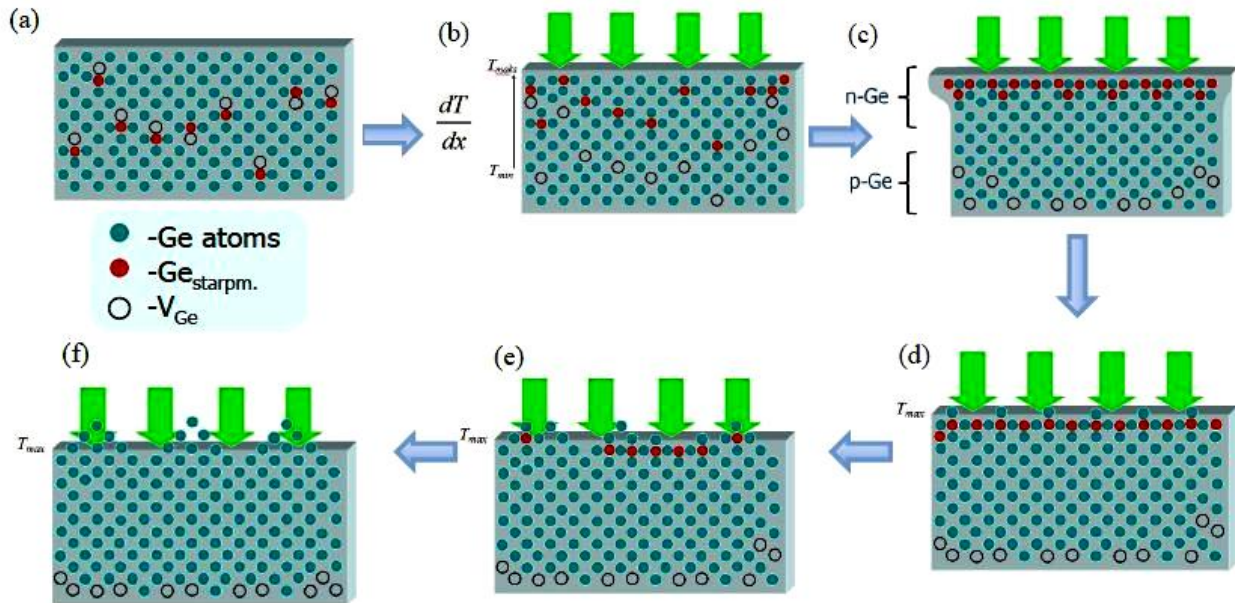

Fig.5 – Schematic image of nanocones formation

ACKNOWLEDGEMENTS

The author gratefully acknowledges financial support in part by Europe Project in the Framework of MATERA+ project, European Regional Development Fund within the project “Sol-gel and laser technologies for the development of nanostructures and barrier

REFERENCES

1. A.P. Alivisatos, *Science* **271**, 933 (1996).
2. Y. Xia, P. Yang, Y. Sun, Y. Wu, B. Mayers, B.Gates, Y. Yin, *Adv. Mater.* **15**, 353 (2003).
3. G. Bastard, *Superlatt. Microstruct.* **3**, 265 (1985).
4. A. Medvid, A. Mychko, O. Strilchyk, N. Litovchenko, Y. Naseka, P. Onufrijevs, A. Pludonis, *phys. status solidi (c)* **6**, 209 (2009).
5. O. Maher, K. Témim, B. Jlassi, J. Balti, S. Jaziri, *J. Phys.: Conf. Ser.* **245**, 012066 (2010).
6. A. Medvid, P. Onufrijevs, A. Mychko, *Nanoscale Res. Lett.* **6**, 582 (2011).
7. A. Medvid', A. Mycko, P. Onufrijevs, E. Dauksta, *Nd YAG Laser: Application of Nd:YAG Laser in Semiconductors' Nanotechnology* (InTech: 2012).
8. A. Medvid, I. Dmytruk, P. Onufrijevs, I. Pundyk, *phys. status solidi (c)* **4**, 3066 (2007).
9. A. Medvid, I. Dmitruk, P. Onufrijevs, I. Pundyk, *Solid State Phen.* **131-133**, 559 (2008).
10. A. Medvid', P. Onufrijevs, K. Lyutovich, M. Oehme, E. Kasper, N. Dmitruk, O. Kondratenko, *J. Nanosci. Nanotech.* **10**, 1094 (2010).
11. A. Medvid, A. Mychko, A. Pludons, Y. Naseka, , *J. Nano Res.* **11**, 107 (2010).
12. A. Medvid, *Defect and Diffusion Forum* **210-212**, 89 (2002).
13. E.S. Cor Claeys: *Germanium-based technologies: from materials to devices* (London: Elsevier B.V.: 2007).