

Dissimilar Materials Laser Welding Characteristics of Stainless Steel and Titanium Alloy

Z. Mohid^{1, a}, M.A. Liman^{1, b}, M.R.A. Rahman¹, N.H. Rafai¹, E.A. Rahim^{1, c}

Advance Machining Research Group, Faculty of Mechanical Engineering & Manufacturing
University Tun Hussein Onn Malaysia, 86400, Parit Raja, Batu Pahat, Johor, Malaysia

^azazuli@uthm.edu.my, ^bmagdelyneansik@yahoo.com, ^cerween@uthm.edu.my

Keywords: Titanium alloy, Stainless steel, Nd:YAG laser, dissimilar material.

Abstract. Welding parameters are directly influenced by the work material properties. Thermal properties such as thermal conductivity and melting point are very important to estimate the range of power required and the allowable scanning speed. However, when two or more different materials are involved, modifying lasing parameters are not enough to counter the problems such as imbalance melting region and weak adhesion of contact surface. To counter this problem, the characteristics of welding beads formation for both materials need to be clarified. In this study, comparison of welding beads constructed using the same scanning parameters were done to understand the different and similarity of melted region for the both materials. Actual welding of the both materials were done under different offset distance to obtain a balanced melting area and well mixed melting region.

Introduction

The advancement of technologies and revolution of engineering have changed the operation and function of materials in many ways. At present time, there is a high concern and demand to produce combined material with superior quality. The metal of different compositions can enhance mechanical wear problem, a high temperature situation or other conditions in which different properties required from different properties parts of same weldment [1]. The combination of dissimilar materials such as titanium alloys (Ti-6Al-4V) and stainless steel (AISI 316L) by using laser welding is seen to provide brilliant solution and alternative toward the problem. A sharp and focus light will be directed from the laser towards both material and causes the small area of metals to melt. These melting parts will then attached and form joint materials. From engineering perspective, the combination between these two material produce a joint product with improved strength and material properties [2]. Beside, this kind of combination is also widely applied in medical, aerospace, military, thermal power station, nuclear industries, micro electronic and automotive field and it due to the location of materials according to design or performance [3].

Laser is the main method that brings to coalescence of Ti6Al4V and AISI 316L. The usage of this method exhibits advantages as it brings the reduction to the cost and leave minimal damage to the work area [2]. The laser parameter plays the vital role in determine the success of the weld part. In the case of welding penetration depth, peak power most influencing in the parameter by peak power under constant pulse duration will increasing the penetration depth [4]. Beside that with under a constant pulse width, the increasing of pulse repetition rate could moderately increase the melted zone depth [5]. The success of the welding can be determined by examination of the microhardness of the weld part, the tensile strength, and the heat affected zone. The welding quality obtained in this process should be in desirable standard in terms of the strength, microstructure and crack. During welding the dissimilar materials, it impossible to direct joint by using conventional welding methods. This is due to the metallurgical will occur when it comes to joint the titanium and stainless steel where it consists a formation of brittle intermetallic phases. Beside that the melted zone in the ranges of the solubility of steel in titanium is impossible to be maintained also. In this study it to produce and analyse the behaviour of the butt weld part between dissimilar material titanium and stainless steel is importance. Beside that to characterize the influence of welding parameter in dissimilar material joining process performed using laser beam welding.

Experiment Procedure

The materials used in this study were titanium alloy (Ti6Al4V) and stainless steel (AISI 316L) sheet with the dimension of 25mm x 5mm x 1.8mm and 25mm x 5mm x 1.0mm respectively. The Ti6Al4V and AISI 316L sheets were chosen because of their wide application in biomedical application[6]. The material properties of both materials are listed in Table 1.

Both materials were irradiated in straight line during the laser welding process. The processing parameter is shown in Table 2. To balance the metal melting condition, the scanning was done with two different distance locations; at the joining gap and 0.2mm shifted to the titanium alloy sheet region. The scanning lines were shifted to Ti6Al4V for its high melting temperature and low thermal conductivity compares to the AISI 316L.

Table 1: Material properties of Ti6Al4V and AISI 316L

Properties		Titanium (Ti6Al4V)	Stainless steel (AISI 316L)
Melting temperature	T_m (°C)	1604 to 1660	1390 to 1400
Deformation temperature	T_d (°C)	980	889
Thermal conductivity	k (W/m.K)	6.7	14.6
Hardness (Vickers)	H_V	349	155
Maximum tensile stress	τ_{max} (Mpa)	950	515

Table 2: Processing parameter

Scanning speed v (mm/min)	Pulse width t_p (ms)	Pulse repetition rate f_p (Hz)	Energy E (J)
50 and 300	0.6, 0.8, 0.9, 1.0	40, 60, 80, 100	0.90, 1.00, 1.15, 1.20, 1.25, 1.50

Fig. 1 shows the schematic diagram of the experimental setup. In actual welding process, the specimens were clamped onto the fixture to avoid any misalignment due to thermal expansion. Butt welding was performed with the focus point of 1.55 mm top of the surface. Laser head with the focus distance and beam diameter of 160 mm and 0.48 mm respectively were used to convey the laser beam on the specimens. Argon gas with flow rate of 7 liter/min was delivered using a nozzle with an inner diameter 6.5 mm. The nozzle was placed with the inclination angle of approximately 45° to specimen surface and the distance of 10 mm from the scanning point.

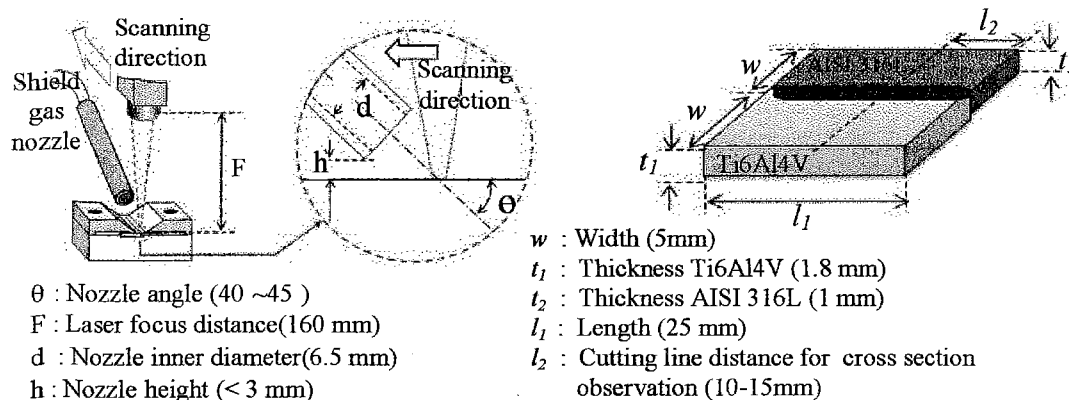

Fig. 1: Schematic diagram of experiment setup

Results and Discussions

Blank Irradiation on AISI 316L and Ti6Al4V. Different combination of parameters, namely pulse width (t_p), pulse repetition rate (f_p) and energy (E) were used to perform a blank irradiation on AISI 316L and Ti6Al4V. This experiment was done to determine an appropriate parameters range which can be applied for the both materials. In the case of t_p and f_p of 1.0 ms and 100 Hz respectively, the laser energy 1.0 to 1.25 J should be employed. Fig. 2 shows the result of the irradiation process. It can be seen from this figure that the burn marks increase as the pulse repetition rate increases. The oxidized layer was clearly observed at higher pulse repetition rate. This layer can be seen once the pulse repetition rate of 60Hz was applied. The occurrence of oxidation can be attributed by the mixing of argon gas with environmental air. Furthermore, improper shielding gas amount supplied during welding process contributed to the oxidation. This oxidation could weaken the joining on both materials.

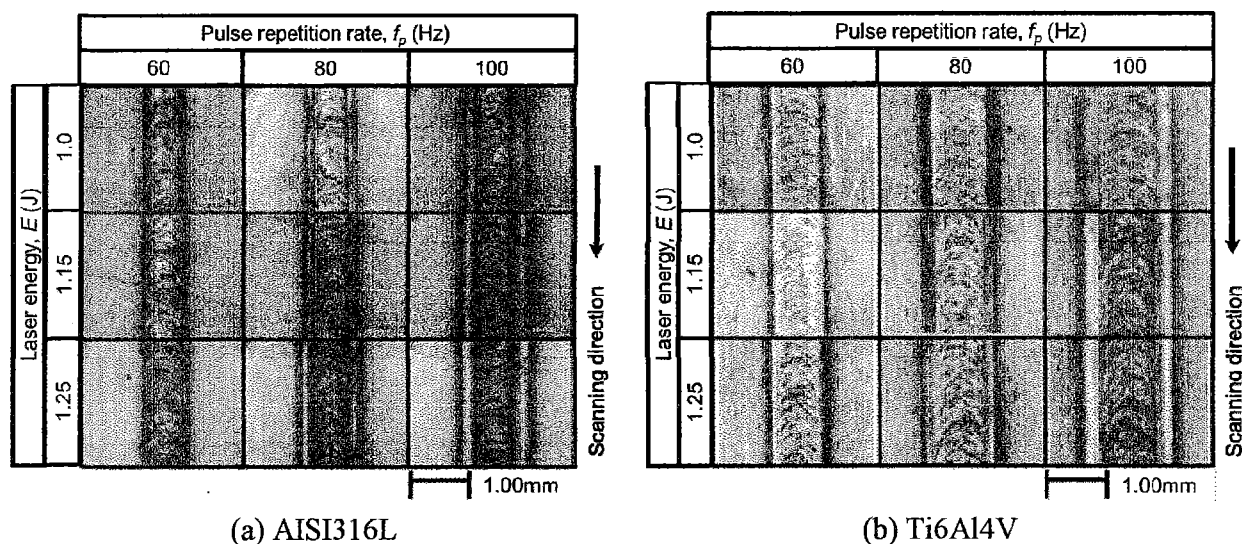

Fig. 2: Magnified view of irradiation line at laser energy E (J) and pulse repetition rate f_p (Hz). (pulse width, $t_p=1.0$ ms) and at fixed pulse width, $t_p=1.0$ ms and scanning speed, $v=300$ mm/min

Dissimilar Material Laser Welding: Fig. 3a shows the top view of dissimilar material joining. It was noted that both material were unable to join at all tested parameter. It can be suggested that the chemical composition of the materials cannot co-exist at the same time. Cross sectional view of the dissimilar material butt joint is shown in Fig. 3b. The measurement was done in order to determine the width and depth of the melted zone. For the HAZ of AISI 316L, the measurement was unable to be performed due to the high value of thermal conductivity compare to the Ti6Al4V. Furthermore, the HAZ of AISI 316L cannot be visualized using the optical microscope. As expected, as the peak power increases, the depth of penetration increases. The overall increment was approximately 30% when the scanning speed was decreased from 300 to 50 mm/min. Decreasing the scanning speed was consequently initiated more heat conduction and heat convection to take place on both materials joining surfaces. The differences of thermal conductivity could be the main reason of the cracks propagation. Referring to the thermal conductivity, the heat induced into the AISI 316L spread two fold faster than Ti6Al4V. Thus in all cases, the melted zone of AISI 316L was always smaller compared to Ti6Al4V. Shifting the laser scanning position to Ti6Al4V has brought inverse effect. The molten zones produced on AISI 316L were much more smaller than Ti6Al4V. Theoretically, by shifting the distance of 0.2 mm from the center of scanning line to the Ti6Al4V region could minimize the heat lost due to the high thermal conductivity of AISI 316L. Practically, the heat energy induced was successfully melted the Ti6Al4V but insufficient to melt the AISI 316L interact area. Further welding trial can be done with the scanning line shifted to AISI 316L, however, higher laser energy need to be employed to compensate the heat lost.

An observation on the melted zone concludes that the occurrence of cracks were due to the changes of mechanical properties of both materials. Combination of molten AISI 316L and Ti6Al4V has created new chemical compositions with different mechanical properties. The molten metals became brittle and could not stand the generation of thermal stress during the welding process. However, further analysis need to be done from the point of material behaviour in elevated temperature.

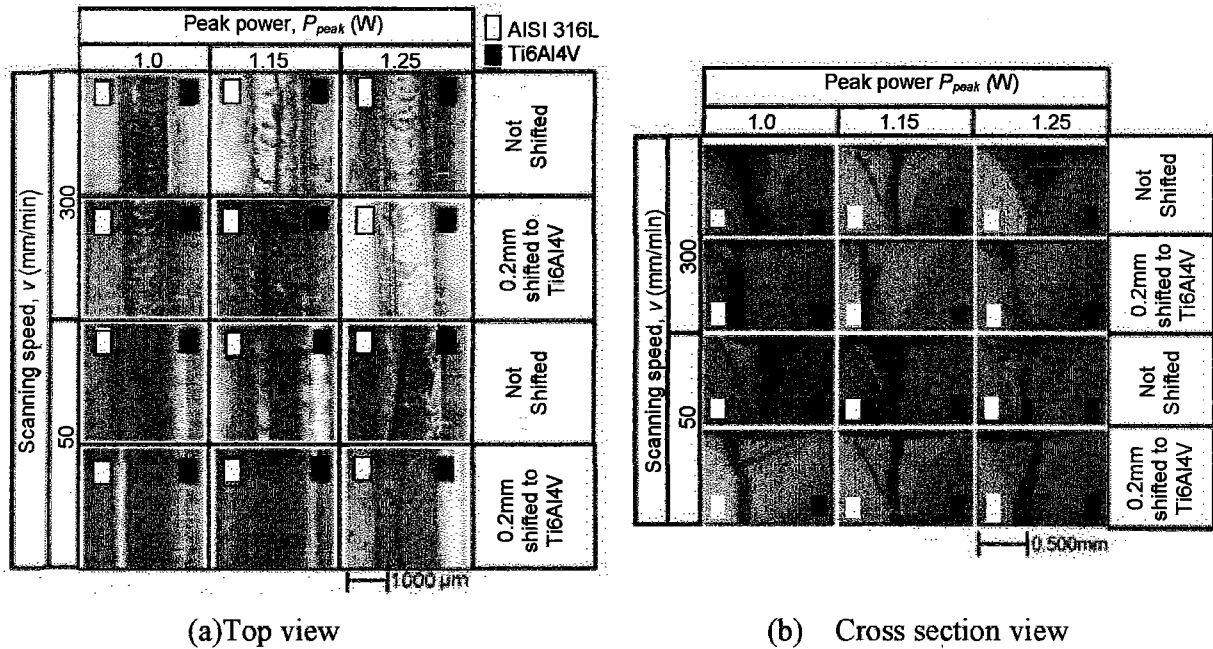

Fig 3: Metallographic image for dissimilar laser welding of 25mm length under different peak power, travel speed, and offset position. ($t_p=1.0ms, v=300\text{ mm/min}, f_p=100Hz$ and focus position - 1.5 below surface)

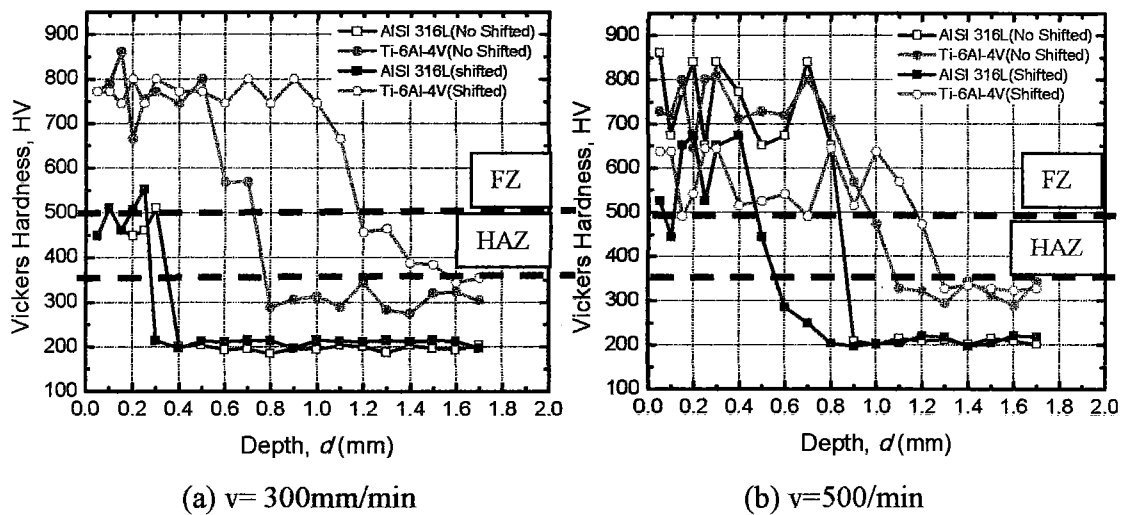

Fig. 4: Microhardness analysis on both AISI 316L and Ti6Al4V with variable scanning speed, peak power and specimen radiate with peak power 1.0kW.

Microhardness Analysis. Hardness measurement was done at the cross sectioned area of both materials. 20 indentions were done on each specimen with the interval distance of 0.1 mm. The changes of hardness value indicate the heat flow characteristics HAZ and border line of each material. The result of microhardness measurement is shown in Fig. 4. As the peak power increase, the depth of fusion zone (FZ) increases. It was noted that the hardness values were inconsistent as

the molten zone increases. This is due to the microstructure arrangement at the FZ areas. The turbulence in the FZ has randomly mixed up the molten metal with different density. Highest value of hardness was obtained at the fusion zone, where the FZ in range 500 to 960 Hv. This is due to the formation of martensite occurring at Ti6Al4V.

Conclusions

The main conclusion drawn from this research can be summarized as follows:

1. The result of melting depth of AISI 316L and Ti6Al4V are different when tested using the same parameter. The melting depth of AISI 316L will always lower than Ti6Al4V when heated using the same laser parameter.
2. Shifting the laser beam to the Ti6Al4V side creates significant melted zone depth and width differences between the both materials. The melted zone size differences decreases as the scanning speed decreased.
3. Low scanning speed allows melted metals to flow and mix in the welding pool. Consequently, large hardness value fluctuation can be seen from the both materials melted zone.
4. The parameters that used to weld both materials are not suitable. All welding conditions produces crack at the middle of the joining area.

Acknowledgement

This study was able to be realized with the support of FRGS grant, Vot 0730 from Ministry of Higher Education of Malaysia.

References

- [1] V. A. Ventrella, J. R. Berretta, W. d. Rossi, Pulsed Nd:YAG laser beam welding of AISI 316L stainless steel thin foils, *Journal of Materials Processing Technology*. 210 (2010) 1838-1843
- [2] B. Shanmugarajan, G. Padmanabham, Fusion welding studies using laser on Ti-SS dissimilar combination, *Optics and laser in Engineering*. 50 (2012) 1621-1627
- [3] Shaogang Wang, Xinqiang Wu, Investigation on the microstructure and mechanical properties of Ti-6Al-4V alloys joints with electron beam welding, *Materials and Design*. 36 (2011) 663-670
- [4] E. Akman, A. Demir, T. Canel, T. Sinmazcelik, Laser welding of Ti6Al4V titanium alloys, *Journal of Material Processing Technology*. 209 (2008) 3705-3713
- [5] Z. Mohid, Z.A. Rashid, A. Wagiman, M.N.H Rafai and E.A. Rahim, Titanium Alloy Welding Using Middle Range Power Pulsed Wave Laser, *Applied Mechanics and Material*. 372 (2013) 486-490
- [6] Bappa Acherjee, Arunanshu S. Kuar, Souren Mitra, Dipten Misra, Finite element simulation of laser transmission welding of dissimilar material between polyvinylidene fluoride and titanium, *International Journal of Engineering, Science and Technology*. 4 (2010) 176-186