

Technical University of Denmark



Load testing circuit

Knott, Arnold

Publication date:
2009

Document Version
Publisher's PDF, also known as Version of record

[Link back to DTU Orbit](#)

Citation (APA):
Knott, A. (2009). IPC No. G01R31/02 . Load testing circuit (Patent No. US2009051368.)

DTU Library

Technical Information Center of Denmark

General rights

Copyright and moral rights for the publications made accessible in the public portal are retained by the authors and/or other copyright owners and it is a condition of accessing publications that users recognise and abide by the legal requirements associated with these rights.

- Users may download and print one copy of any publication from the public portal for the purpose of private study or research.
- You may not further distribute the material or use it for any profit-making activity or commercial gain
- You may freely distribute the URL identifying the publication in the public portal

If you believe that this document breaches copyright please contact us providing details, and we will remove access to the work immediately and investigate your claim.



US008525536B2

(12) **United States Patent**
Knott

(10) **Patent No.:** **US 8,525,536 B2**

(45) **Date of Patent:** **Sep. 3, 2013**

(54) **LOAD TESTING CIRCUIT**

(75) Inventor: **Arnold Knott**, Michaelsbuch (DE)

(73) Assignee: **Harman Becker Automotive Systems GmbH**, Karlsbad (DE)

(*) Notice: Subject to any disclaimer, the term of this patent is extended or adjusted under 35 U.S.C. 154(b) by 354 days.

(21) Appl. No.: **12/126,178**

(22) Filed: **May 23, 2008**

(65) **Prior Publication Data**

US 2009/0051368 A1 Feb. 26, 2009

(30) **Foreign Application Priority Data**

May 23, 2007 (EP) 07010276

(51) **Int. Cl.**

H03K 5/01 (2006.01)

H04R 29/00 (2006.01)

H03H 7/38 (2006.01)

(52) **U.S. Cl.**

USPC **324/713**; 327/100; 381/58; 333/124

(58) **Field of Classification Search**

USPC 324/713-718; 327/100; 381/58-60, 381/96, 111, 116; 333/124, 17.3, 32

See application file for complete search history.

(56) **References Cited**

U.S. PATENT DOCUMENTS

3,067,297	A *	12/1962	Fink	381/1
3,832,572	A *	8/1974	Minamihata et al.	307/106
4,550,277	A *	10/1985	Carney	388/809
4,683,591	A *	7/1987	Dawson et al.	381/85
5,205,619	A	4/1993	Holst et al.	
5,233,496	A	8/1993	Morishige	
5,496,178	A *	3/1996	Back	434/307 A
5,568,342	A *	10/1996	Tavazzani et al.	361/18
5,587,894	A *	12/1996	Naruo	363/84
5,719,526	A	2/1998	Fink	
6,184,919	B1 *	2/2001	Asprey et al.	725/148
6,707,919	B2 *	3/2004	Koval et al.	381/100
2002/0149424	A1 *	10/2002	Honda	330/207 A
2004/0086140	A1 *	5/2004	Fedigan et al.	381/96
2007/0057720	A1 *	3/2007	Hand et al.	330/10

* cited by examiner

Primary Examiner — Melissa Koval

Assistant Examiner — Farhana Hoque

(74) *Attorney, Agent, or Firm* — O'Shea Getz P.C.

(57) **ABSTRACT**

A load testing circuit a circuit tests the load impedance of a load connected to an amplifier. The load impedance includes a first terminal and a second terminal, the load testing circuit comprising a signal generator providing a test signal of a defined bandwidth to the first terminal of the load impedance, an energy-storing element being connected to the second terminal of the load impedance and providing an output signal, and a measuring unit that measures the output signal or compares the output signal with a reference.

8 Claims, 4 Drawing Sheets

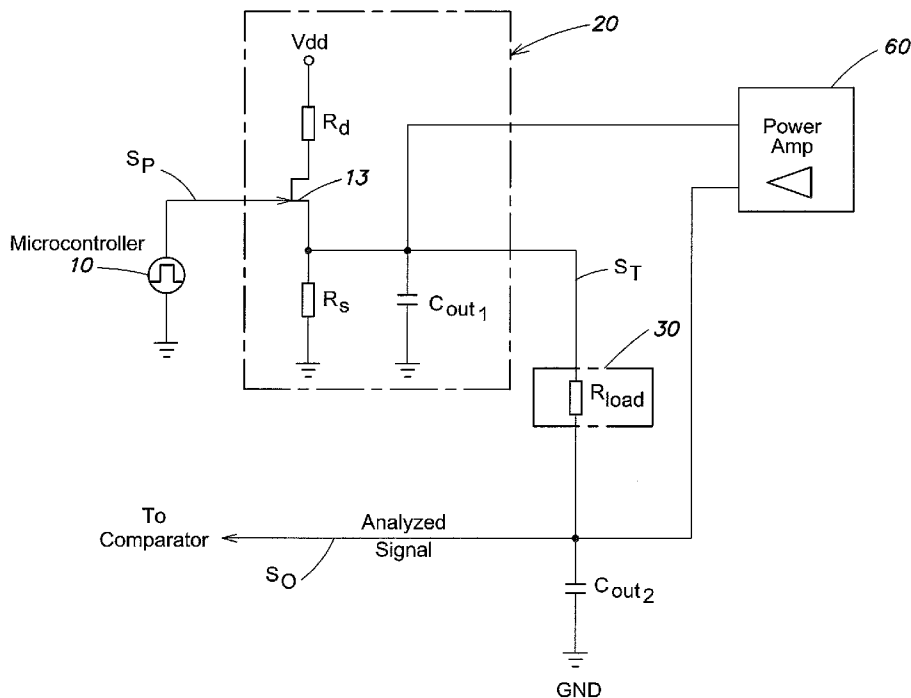

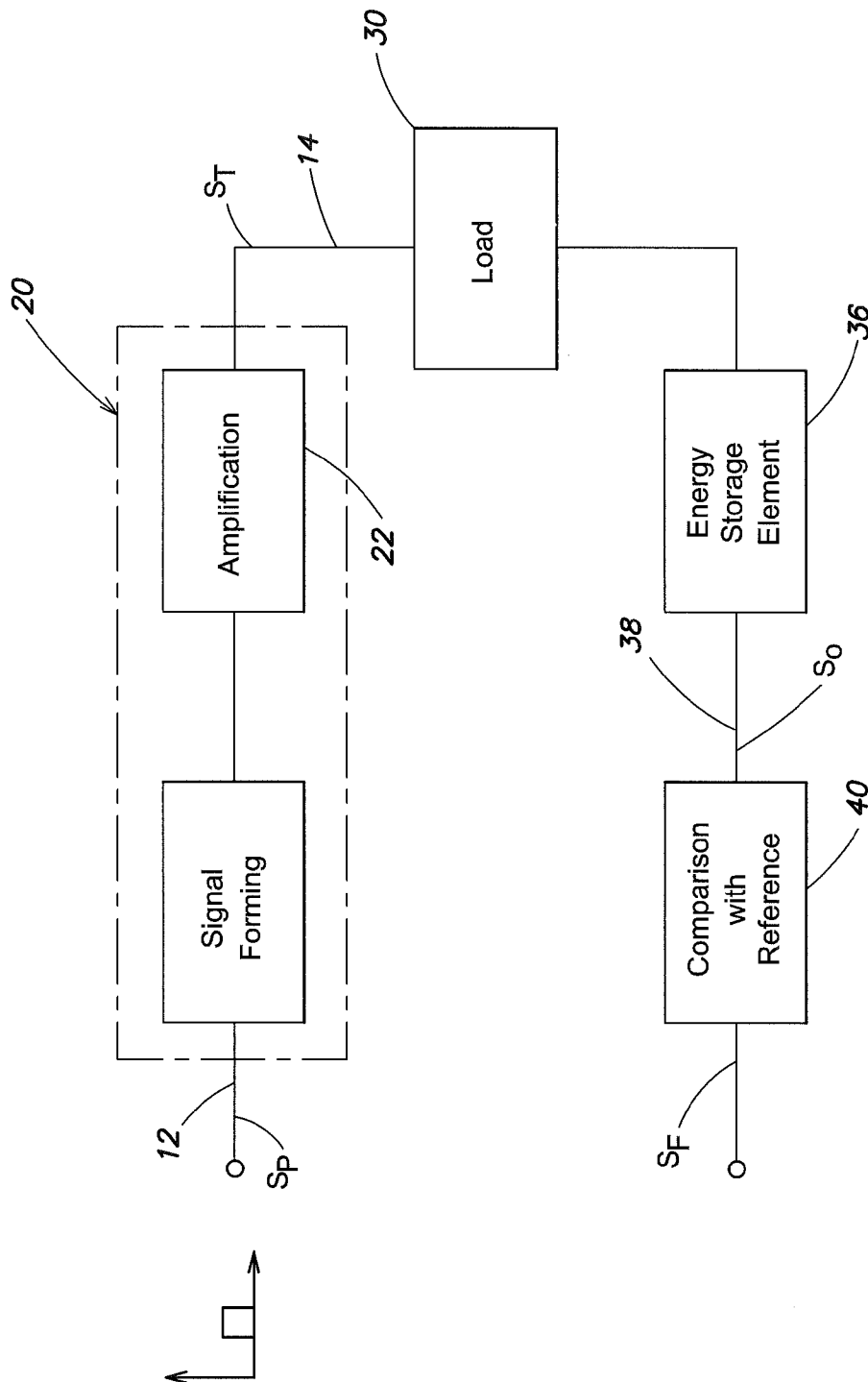

FIG. 1

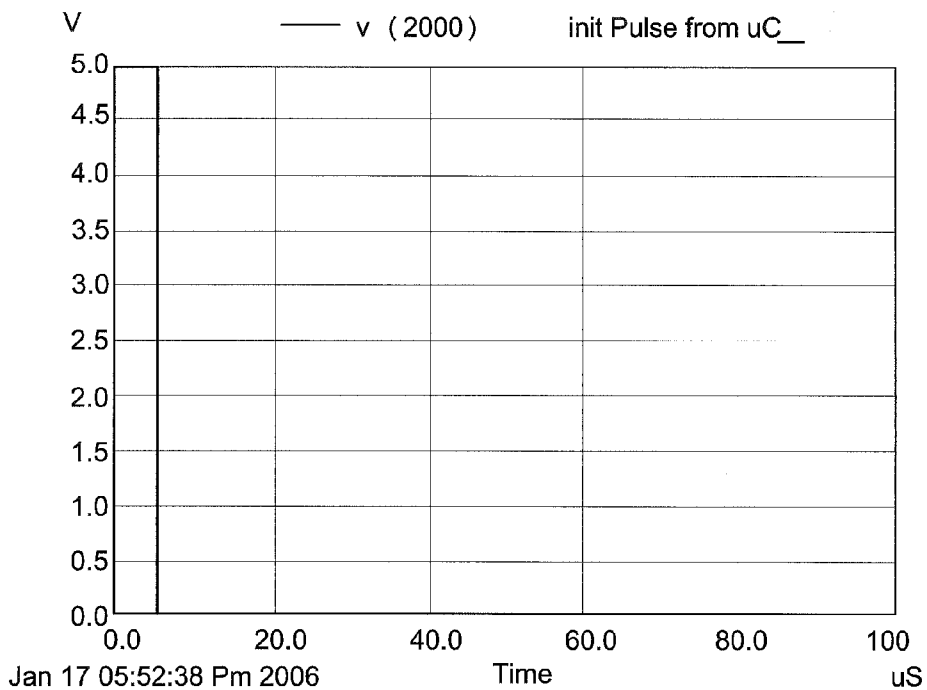

FIG. 3

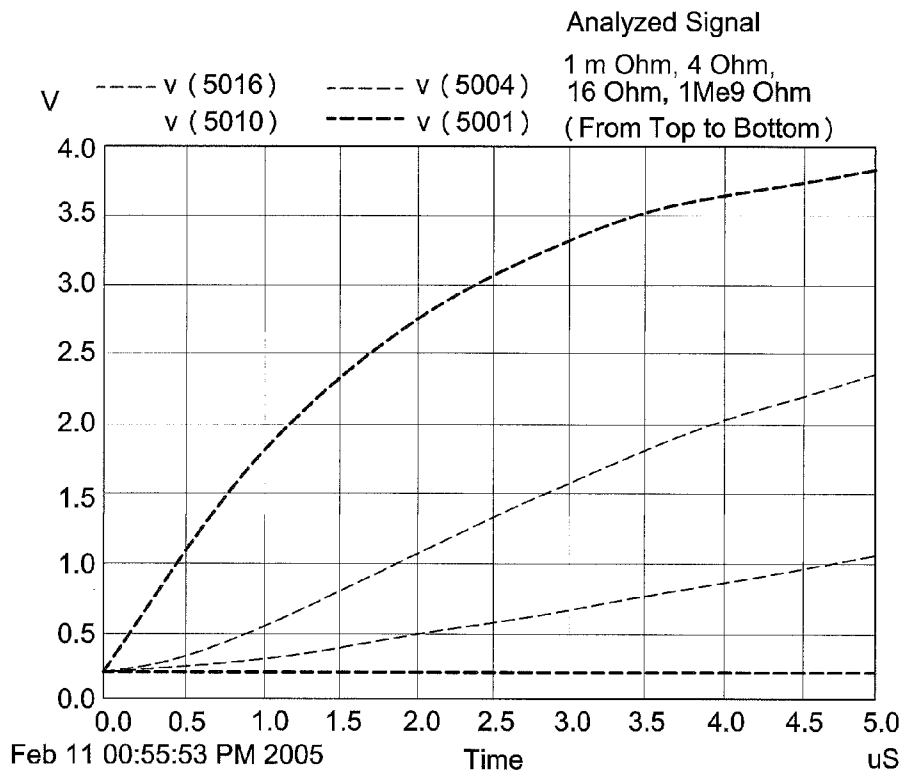

FIG. 4

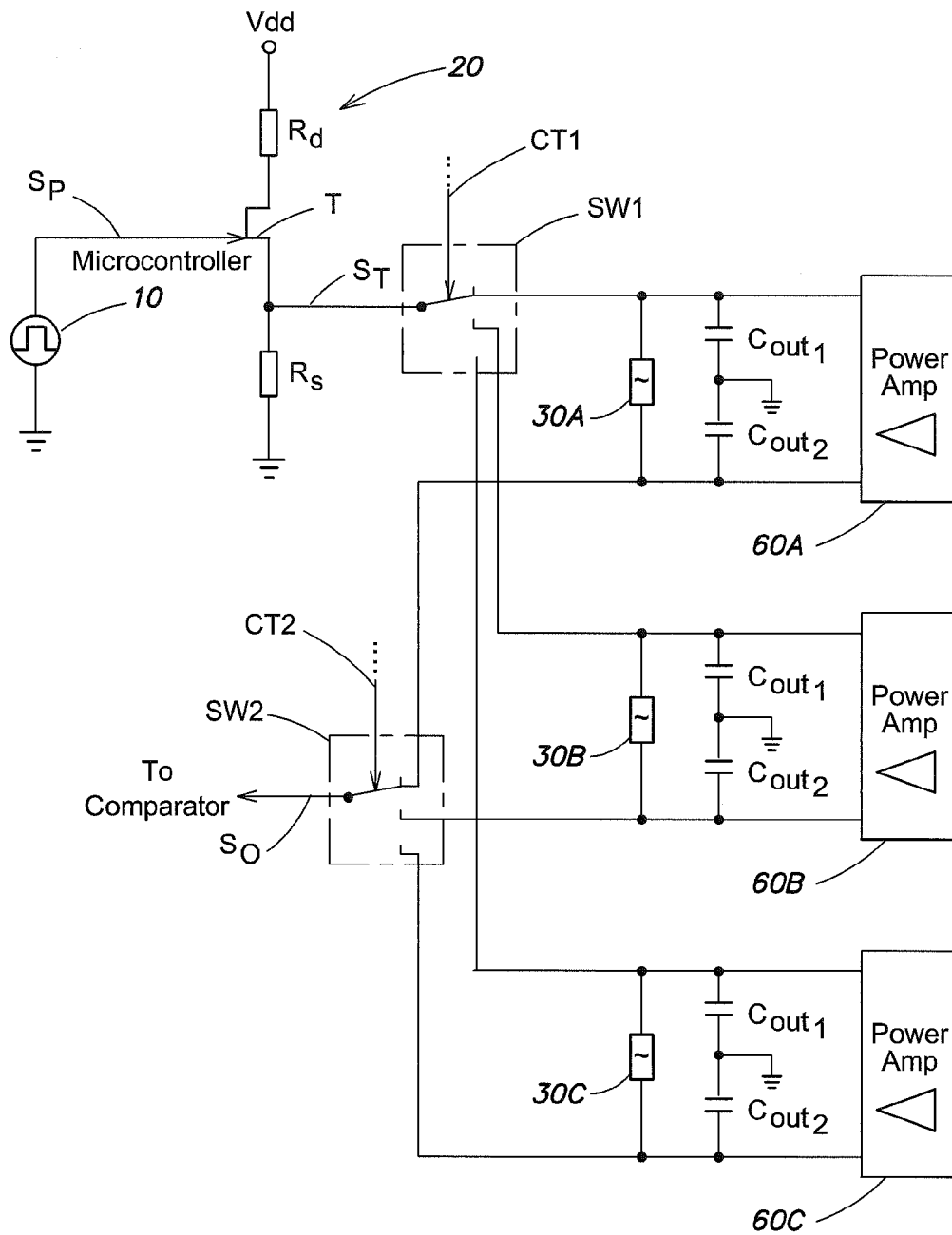

FIG. 5

1

LOAD TESTING CIRCUIT

CLAIM OF PRIORITY

This patent application claims priority to European Patent Application serial number 07 010 276.9 filed on May 23, 2007.

FIELD OF THE INVENTION

The invention relates to a load testing circuit, and in particular to a load testing circuit for detecting the presence of a defined load impedance connected to the output of a power amplifier.

RELATED ART

Many amplifier circuits require overload protection for protecting their output-stages against destruction due to inappropriate loads attached thereto. Suitable loudspeakers (or other electro-acoustic transducers) are a prerequisite for a correct function of the associated amplifiers.

Modern amplifiers are often controlled by microcontrollers that perform many different tasks, such as selecting signal sources, processing user input, and so on. Microcontrollers are also useful for fault-detection. There is a need for a test circuit that allows for easily interfacing with a microcontroller and detects inappropriate electro-acoustic transducers attached to an output-stage of a power amplifier in order to protect the output stage.

SUMMARY OF THE INVENTION

A test circuit for detecting a defined load of an electro-acoustic transducer comprises a signal generator that provides a test signal of a defined bandwidth, an electro-acoustic transducer having a first and a second terminal, the first terminal being connected to the signal generator for receiving the test signal, an energy-storing element being connected to the second terminal of the electro-acoustic transducer, and providing an output signal, and measuring unit that measures the output signal or compares the output signal with a reference.

A method for testing an electro-acoustic transducer comprises providing a test signal of a defined bandwidth, supplying the test signal to a first terminal of an electro-acoustic transducer, thereby providing an output signal at the second terminal of the electro-acoustic transducer, measuring the output signal or for comparing the output signal with a reference.

DESCRIPTION OF THE DRAWINGS

The present invention can be better understood with reference to the following drawings and the description. The components in the figures are not necessarily to scale, emphasis instead being placed upon illustrating the principles of the invention. Moreover, in the figures, like reference numerals designate corresponding parts throughout the different views.

FIG. 1 is a block diagram illustration of a load testing circuit;

FIG. 2 is a more detailed circuit diagram of the load testing circuit illustrated in FIG. 1;

FIG. 3 is a timing diagram illustrating a test signal before low-pass filtering;

2

FIG. 4 is a timing diagram illustrating different output signals corresponding to different impedance values of the load; and

FIG. 5 is a circuit diagram of another example of the load testing circuit.

DETAILED DESCRIPTION

Referring to FIG. 1, a pulse signal S_P on a line 12 is provided, for example, by a microcontroller (not shown). The pulse may be generated at an I/O-pin of an I/O-port of the micro-controller. Alternatively, a digital-to-analog converter output of the microcontroller may be used to provide the pulse signal S_P on the line 12. The pulse signal comprises at least one pulse which is, for example, rectangular, and has a spectral bandwidth that may comprise at least parts of the spectral range audible by the human ear.

A test signal S_T on a line 14 is derived from the pulse signal S_P on the line 12 by a signal shaping circuit 20. The test signal S_T has a defined bandwidth determined by a transfer function of the signal shaping circuit 20. The bandwidth of the low-pass and/or the band-pass usually depends on the bandwidth of the electro-acoustic transducer (e.g., a loudspeaker) that forms the load 30. As an example, the bandwidth of the band-pass may correspond to the bandwidth of the human ear, which is about 20 kilohertz starting from approximately 20 Hertz. Alternatively, the signal shaping may already be performed by the above-mentioned analog-to-digital converter by converting an arbitrary synthesized signal of the desired bandwidth.

The signal shaping circuit 20 may also include an amplifier 22 to provide the test signals S_T on the line 14 having higher levels than the original pulse signal S_P or to perform an impedance conversion providing a low-output resistance of the signal shaping circuit 20. The signal shaping circuit 20 is connected to a first terminal of the load 30 (e.g., the electro-acoustic transducer) supplying the test signal S_T to the load 30. A second terminal of the load 30 is connected to an energy storing element 36 which may be, for example, a capacitor C_{OUT2} as illustrated in FIG. 2. Capacitors are usually connected parallel to the output of an amplifier for electromagnetic compatibility (EMC) and electrostatic discharge (ESD) protection. These capacitors can be used as capacitors C_{OUT1} and C_{OUT2} illustrated in FIG. 2.

The energy storing element 36 provides an output signal S_O on a line 38 to a comparator 40. The energy storing element is connected to the load 30, such that the load's impedance and energy storing element form a filter circuit disposed downstream of the signal forming circuit 20. This filter circuit may represent a low-pass as illustrated in FIG. 2 or a band-pass, but the use of other filter characteristics is of course also applicable to the inventive test circuit of the present invention. In each case, the filter characteristics can be interpreted as a representation of the (generally complex) load impedance. In the case of a low-pass filter, the cut-off frequency, and respectively the time constant, of the low-pass depends on the load impedance.

The output signal S_O on the line 38 is supplied to the comparator 40, such as for example a window-comparator or a Schmitt-trigger for comparing the output signal on the line 38 to a threshold. The output signal S_O on the line 38 essentially represents the impulse response (of a band-limited pulse of the test signal S_T) of a system formed by the load 30 and the energy storing element 36. Consequently, the load impedance is also represented by the slope of the output signal S_O , such that the lower the load impedance, the steeper the slope of the output signal and the earlier a given threshold

is reached by the output signal S_O on the line **38**. That is, the time period between initiation of the pulse signal S_P (or the test signal S_T) and the triggering of the comparator **40** by the output signal S_O represents the load impedance. This time period can easily be measured by a microcontroller. Alternatively, the output-signal can be directly supplied to an analog-to-digital converter port (A/D-port) of the microcontroller. In this case the functionality of the comparator **40** (or any other, even more complex analysis) can be implemented in the microcontroller.

If the microcontroller detects an inappropriate load impedance **30** it can initiate appropriate measures for protecting the power-amplifier output-stage to which the load-impedance is connected. Thus the above-described circuit can be used for overload protection of a output-stage of a power amplifier. For example, the microcontroller may deactivate the output-stage as long as it senses an unsuitable load impedance **30** (e.g., unsuitable loudspeakers) at the output of the power amplifier.

FIG. **2** illustrates an embodiment of the circuit of FIG. **1**. The pulse signal S_P on the line **12** can be generated by microcontroller **10**. Therefore, for example, an output pin of the microcontroller can be connected to the signal shaping circuit **20**. In the example of FIG. **2** the pulse signal S_P is received by the gate terminal of a junction field-effect transistor **13**. It is contemplated that other types of transistors can be used for this purpose as well. The drain terminal of the transistor **13** is connected to a first supply terminal receiving a first supply potential V_{DD} via a resistor R_d . The source terminal of the transistor **13** is connected to a second supply terminal receiving a second supply potential (e.g., ground potential GND) via resistor R_s . A first capacitor C_{out1} is connected in parallel to the source resistor R_s . The test signal S_T is provided by the source terminal of transistor **13**, which is also connected to a first terminal of the load impedance (comprising a resistance R_{load}). The transistor circuit within the signal shaping circuit **20** essentially forms a source-follower with source resistor R_s , a drain resistor R_d and the first capacitor C_{out1} . The drain and source resistors R_d and R_s , form, together with the first capacitor C_{out1} , a first low pass, thus limiting the band width of the pulses in the pulse signal S_P for providing a band limited test signal S_T to the load impedance. This band limitation has to be performed, because some loads, especially electro-acoustic-transducers react in a bad manner or even can be destroyed if too high slopes (occurring for example in rectangular pulses) are applied.

The second terminal of the load **30** is connected to the second supply terminal (ground potential) via an energy storing element such as a second capacitor C_{out2} in the present embodiment. As it can be easily seen from FIG. **2**, the load **30** and the second capacitor C_{out2} form a second low pass filter receiving the test signal S_T and providing the output signal S_O on the line **38**. This output signal can be supplied to the comparator **40** (not shown in FIG. **2**) or directly to an A/D-Port of a microcontroller as explained above reference to FIG. **1**. The output stage of a power amplifier **60** is connected to the first and the second terminal of the load **30**. The circuit of FIG. **2** can be used also for overload protection of the output stage. The microcontroller can therefore keep the output stage deactivated until the correct load impedance, i.e., an appropriate electro-acoustic transducer is detected.

FIGS. **3** and **4** illustrate some exemplary experimental data. FIG. **3** is a timing diagram showing an exemplary pulse signal S_P having a pulse width of 5 ms. FIG. **4** shows output signals S_O for different load impedances (e.g., 1 m Ω , 4 Ω , 16 Ω , 1 M Ω). If the output signal S_O is supplied to a comparator, an appropriate threshold value may be, for example, 2 volts.

Assuming further, the threshold level is reached within about 4 μ s, then it can be concluded the load impedance is about 4 Ω . If the threshold level is reached in a shorter time, the impedance is too low, whereas, if the threshold value is reached later, the impedance is too high.

FIG. **5** illustrates another embodiment of a load testing circuit. By employing multiplex-switches SW1 and SW2 the signal shaping circuit **20** can be used for different amplifiers. In the shown example each of the three power amplifier **60A**, **60B**, **60C** has an associated load **30A**, **30B**, **30C**, respectively, connected to its output terminals. A first capacitor C_{OUT1} and a second capacitor C_{OUT2} are connected between the first output terminal of the amplifier and the reference potential (e.g., ground potential GND) and a second output terminal of the amplifier and the reference potential, respectively. As mentioned above the capacitors C_{OUT1} and C_{OUT2} may be part of the amplifier output stage.

The first output terminals of each of the amplifiers **60A**, **60B**, and **60C** and the signal shaping circuit **20** are connected to the multiplex-switch SW1 such that either the first amplifier **60A**, the second amplifier **60B**, or the third amplifier **60C** is connected to the signal shaping circuit **20**. The second output terminals of each of the amplifiers **60A**, **60B**, and **60C** and the signal shaping circuit **20** are connected to the multiplex-switch SW2 such that either the first amplifier **60A**, the second amplifier **60B**, or the third amplifier **60C** is connected to the comparator (not shown). Of course the multiplex-switches SW1 and SW2 have to switch synchronous, i.e., if the first output terminal of the second amplifier **60B** is connected to the signal shaping circuit **20**, then the second output terminal of second amplifier **60B** has to be connected to the comparator.

The multiplex-switches SW1 and SW2 may be controlled by control signals CT1 and CT2 generated by the microcontroller **10**. In each switching state of the multiplex-switches SW1 and SW2 a circuit as depicted in FIG. **2** is effectively achieved, where the connected amplifier can be switched. One of ordinary skill will immediately recognize that variations and modifications of the circuit explained with respect to the example of FIG. **2** are also applicable to the exemplary circuit of FIG. **5**. The number of connectable amplifiers is of course not limited to three.

It is to be understood, that the invention is not limited to detection of the load impedances of electro-acoustic transducers connected to the output stage of an amplifier, but may be employed to detect any load impedance connected to an arbitrary power supply. Dependent on the application, the capacitors C_{OUT1} and C_{OUT2} may be replaced by inductors.

Although various examples to realize the invention have been disclosed, it will be apparent to those skilled in the art that various changes and modifications can be made which will achieve some of the advantages of the invention without departing from the spirit and scope of the invention. It will be obvious to those reasonably skilled in the art that other components performing the same functions may be suitably substituted. Such modifications to the inventive concept are intended to be covered by the appended claims.

What is claimed is:

1. A loudspeaker load testing circuit for detecting the impedance of a loudspeaker, the loudspeaker load testing circuit comprising:

- a loudspeaker having a first terminal and a second terminal;
- a test signal generator that is connected to the first terminal of the loudspeaker to provide a test signal of a defined bandwidth to the first terminal of the loudspeaker;

5

an energy-storing element having a first element lead connected to the second terminal of the loudspeaker and a second element lead connected to a reference voltage; and

a measuring unit that compares an output signal value at the second terminal of the loudspeaker to determine if the output signal value exceeds a threshold value, where the test signal generator comprises a microcontroller, and an amplifier that provides the drive signal, where the test signal generator further comprises a signal shaping circuit connected to an output pin of the microcontroller for providing the test signal.

2. The test circuit of claim 1, where the signal shaping circuit comprises a low-pass filter for determining the bandwidth of the test signal.

3. The test circuit of claim 1, where the signal shaping circuit comprises:

a semiconductor switch with a control terminal, a first and a second load terminal, the control terminal being connected to an output of the microcontroller;

a first resistor connecting a first supply terminal and the first load terminal of the semiconductor switch;

a second resistor connecting the second load terminal of the semiconductor switch and a second supply terminal; and

a capacitor connected in parallel to the second resistor.

4. A loudspeaker load testing circuit for detecting the impedance of a loudspeaker, the loudspeaker load testing circuit comprising:

a loudspeaker having a first terminal and a second terminal; a test signal generator that is connected to the first terminal of the loudspeaker to provide a test signal of a defined bandwidth to the first terminal of the loudspeaker;

an energy-storing element having a first element lead connected to the second terminal of the loudspeaker and a second element lead connected to a reference voltage; and

a measuring unit that compares an output signal value at the second terminal of the loudspeaker to determine if the output signal value exceeds a threshold value, where the measurement unit comprises a threshold detector,

6

where the threshold detector comprises a Schmitt-Trigger.

5. A loudspeaker load testing circuit for detecting the impedance of a loudspeaker, the loudspeaker load testing circuit comprising:

a loudspeaker having a first terminal and a second terminal; a test signal generator that is connected to the first terminal of the loudspeaker to provide a test signal of a defined bandwidth to the first terminal of the loudspeaker;

an energy-storing element having a first element lead connected to the second terminal of the loudspeaker and a second element lead connected to a reference voltage; and

a measuring unit that compares an output signal value at the second terminal of the loudspeaker to determine if the output signal value exceeds a threshold value, where the measurement unit comprises a threshold detector, where the threshold detector comprises a window-comparator.

6. A loudspeaker load testing circuit for detecting the impedance of a loudspeaker, the loudspeaker load testing circuit comprising:

a loudspeaker having a first terminal and a second terminal; a test signal generator that is connected to the first terminal of the loudspeaker to provide a test signal of a defined bandwidth to the first terminal of the loudspeaker;

an energy-storing element having a first element lead connected to the second terminal of the loudspeaker and a second element lead connected to a reference voltage; and

a measuring unit that compares an output signal value at the second terminal of the loudspeaker to determine if the output signal value exceeds a threshold value, where the test circuit is switchable to different load impedances of different amplifiers by multiplex-switches.

7. The test circuit of claim 6, where the energy-storing element comprises an inductive element.

8. The test circuit of claim 6, where the energy-storing element comprises a capacitive element.

* * * * *