

## Introducing an Invention: Puzzle Shaped Cast for Upper Limb Fractures

Solmaz Ehteshami Afshar<sup>1, 2\*</sup>

1. University of British Columbia, Vancouver, Canada
2. Shahid Beheshti University of Medical Sciences, Tehran, Iran

\*Corresponding Author: Solmaz Ehteshami Afshar, MD, University of British Columbia (UBC), Vancouver, Canada  
Email: [solmaz.ehteshamiazafshar@gmail.com](mailto:solmaz.ehteshamiazafshar@gmail.com)

### Abstract

Upper limb fractures are prevalent injuries. An essential element of fracture healing is to maintain the bones alignment. However there are lots of complications associated with traditional ways of treatment, such as compartment syndrome and stiffness due to immobility for long time. Also evaluation and observation of the limb under the casts for potential infections and skin issues are not possible. By this article an invention of puzzle shaped cast for upper limb is introduced. This novel cast is made up of different parts that they complete each other and join as pieces of a puzzle to shape a cast. By this mean physical examination during the healing process is possible and the complications could be less.

**Keywords:** Puzzle Shaped Cast, Limb Fractures, Invention

**Article History:** Received: 2 Jul 2014; Revised: 25 Sep 2014; Accepted: 19 Oct 2014

**Cite this article as:** Ehteshami Afshar S. Introducing an invention: puzzle shaped cast for upper limb fractures. Int J Travel Med Glob Health. 2015;3(1):3-4.

Upper limb fractures are prevalent injuries. Only distal radius fractures account for approximately 15% of all fractures in adults [1]. Fractures of the distal third of the forearm are the most common fractures of childhood [2]. An essential element of fracture healing is to maintain the bony alignment. Plaster casts were applied for treating the patients with fractures before, and then fiberglass takes their place [3, 4]. But usage of casts is associated with various complications [1]. Although these complications are uncommon, they can be more severe than many clinician's estimate [3]. Especially soft tissue complications could be more problematic than the bone injury itself [1].

Stiffness is a potential complication in the management of upper limb fractures which might limit the movement [5, 6]. Patients will go through rehabilitation sessions for several months after removing the cast and eventually if the stiffness persist surgical intervention should be considered [5, 7]. Also acute carpal tunnel syndrome can occur due to mall positioning of the limb in the cast [1]. The first step in the management of acute carpal tunnel syndrome is placing the wrist in a neutral position without a dressing. If this step does not improve the nerve function should be decompressed surgically. Delayed treatment can result in permanent median nerve dysfunction [1]. Moreover the compartment syndrome which develops slowly with progressively increasing symptoms may occur [1]. When compartment syndrome is suspected, removal of any constrictive dressings is an initial step for accurate assessment of the limb and also for minimizing the squeals [8, 9]. Physical examination findings include tense compartments, pain out of proportion to the injury, and pain with passive stretch of the involved compartment [1]. There are various complications associated with

compartment syndrome such as contractures, neurological deficits, and complete loss of forearm and hand function [8]. The radial nerve can also be injured by a poorly molded splint or cast [1]. Complex regional pain syndrome (CRPS) is another complication which is an abnormally intense, prolonged pain response that is disproportionate to the actual tissue damage. Early intervention is needed for the treatment [1]. Also tearing of the skin may occur during the injury or manual reduction of the fracture. However, the majority of skin complications are secondary to splint or cast application [1]. Infection is also an important complication which is mostly occurred in compound fractures and operatively treated fractures [10]. The infectious complications range from mild, local skin infections, such as cellulitis or abscess, to life-threatening conditions such as necrotizing fasciitis, gangrene, or TSS [3, 10]. Especially wet fiberglass can lead to moist padding, skin breakdown, and potential infection [4]. Almost all of these complications can be diagnosed by simple inspection of the skin under the cast or splint, as well as thorough neurovascular examination of the affected extremity. Thus complete removal of the cast or splint is necessary to fully expose the affected extremity for a complete examination [4]. However this might be a challenge in the potentially rushed environment of a busy emergency department and may cause significant morbidity and mortality. Thus coming up with novel ideas to solve this problem seems crucial. By this article an invention of puzzle shaped cast for upper limb is introduced. As shown in figure one this novel cast is made up of different parts that they complete each other and join as pieces of a puzzle to shape a cast. There are several advantages in using puzzle cast. First, opening up the puzzle cast for inspecting the limb and examining it is so much simpler and faster.

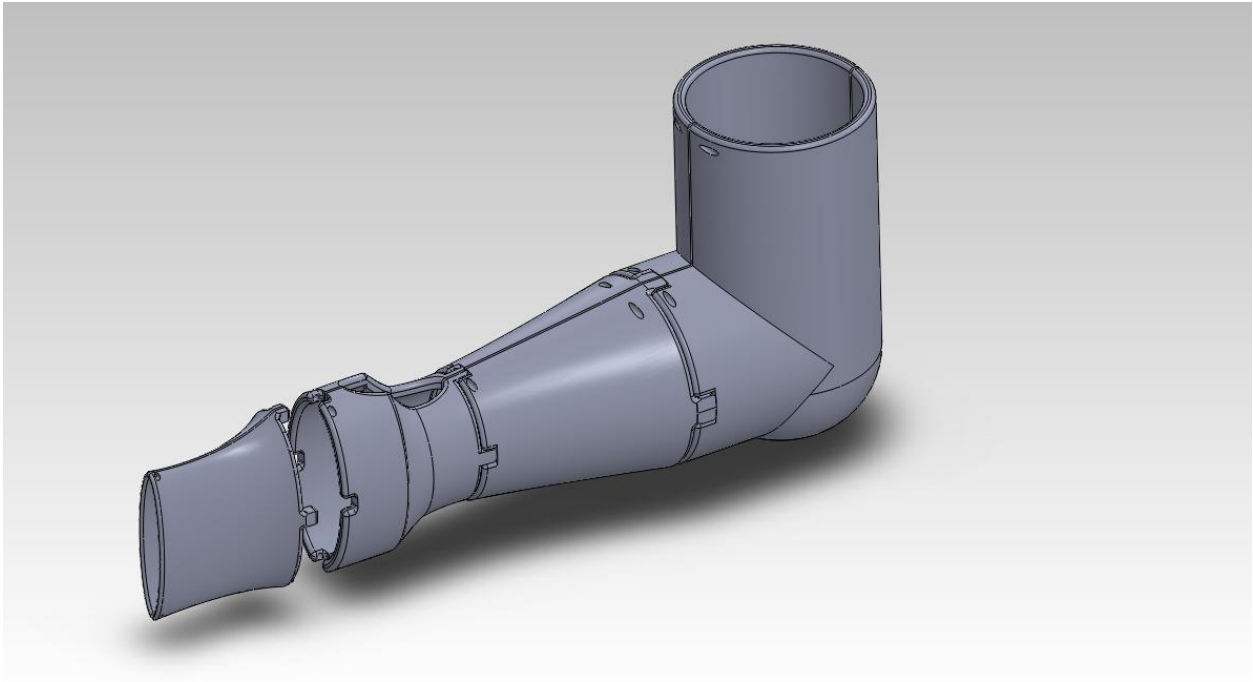

**Figure 1.** Puzzle shaped cast

So the injuries to the soft tissues that were mentioned before would not be missed easily and early identification and prompt treatment can reduce the long-term effects of some complications. A thorough physical examination during follow up visits to address any tendon injury, nerve dysfunction, vascular compromise, skin problem, compartment syndrome, CRPS, or ligament dysfunction that may arise is possible without any difficulties.

Patients that cannot effectively communicate like those with altered mental status, multi-trauma, developmental delay, old patients or those with decreased sensation (nerve blocks, neuropathies), immune compromised, spasticity or cerebral palsy are at highest risk for cast related complications [3]. Thus, usage of puzzle shaped cast would make it possible to examine the patients regularly and diagnose the complications promptly as numerous complications may occur and go unrecognized if not actively sought.

Moreover, the cast which used an acute setting might become loose once the swellings were reduced so changing it would be essential. However in puzzle shaped cast fitting the cast in each visit could be done by just fastening the belt tighter or looser without the need of changing the cast. Also conversion to lower elbow cast would be more convenient.

Although this invention seems better than older casts theoretically, further investigation for assessing its function in practice and also its costs and benefits is needed.

#### **Acknowledgments**

Patent number: 84057

#### **Authors' Contributions**

Ehteshami Afshar was involved in the study and revision of the manuscript.

#### **Funding/Support**

Not declared.

#### **Financial Disclosure**

The author declared no financial disclosure.

#### **References**

1. Davis DI, Baratz M. Soft tissue complications of distal radius fractures. *Hand Clin.* 2010;26(2):229-35.
2. Bohm ER, Bubbar V, Yong Hing K, Dzus A. Above and below-the-elbow plaster casts for distal forearm fractures in children. A randomized controlled trial. *J Bone Joint Surg Am.* 2006;88(1):1-8.
3. Delasobera BE, Place R, Howell J, Davis JE. Serious infectious complications related to extremity cast/splint placement in children. *J Emerg Med.* 2011;41(1):47-50.
4. Williams M. The patient's experience in a plaster cast. *Int Journal of Orthopaedic and Trauma Nursing.* 2010;14:132-41.
5. Kleinman WB. Distal radius instability and stiffness: common complications of distal radius fractures. *Hand Clin.* 2010;26(2):245-64.
6. Ceroni D, Martin X, Delhumeau C, Farpour-Lambert N. Decrease of physical activity level in adolescents with limb fractures: an accelerometer-based activity monitor study. *BMC Musculoskelet Disord.* 2011 May 4; 12:87.
7. Colaris JW, Allema JH, Biter LU, Reijman M, van de Ven CP, de Vries MR, et al. Conversion to below-elbow cast after 3 weeks is safe for diaphyseal both-bone forearm fractures in children. *Acta Orthop.* 2013;84(5):489-94.
8. Kalyani BS, Fisher BE, Roberts CS, Giannoudis PV. Compartment syndrome of the forearm: a systematic review. *J Hand Surg Am.* 2011;36(3):535-43.
9. Grottkau BE, Epps HR, Di Scala C. Compartment syndrome in children and adolescents. *J Pediatr Surg.* 2005;40(4):678-82.
10. Turner RG, Faber KJ, Athwal GS. Complications of distal radius fractures. *Hand Clin.* 2010;26(1):85-96.