

Implications for Better Container Transit in the Lower Mekong River through the Field Survey and Policy Simulation

Takashi Shimada^{1*}, Ryuichi Shibasaki², Hidetoshi Kume³, and Masaru Suzuki⁴

¹Senior Director for Researcher, The Overseas Coastal Area Development Institute of Japan
1-6-2 Kojimachi, Chiyoda-ku, Tokyo, 102-0083, Japan

²Associate Professor, Department of Systems Innovation, School of Engineering, the University of Tokyo
7-3-1 Hongo, Bunkyo-ku, Tokyo, 113-8656, Japan

³JICA advisor for the Ministry of Public Works and Transport of Cambodia
Corner Norodom Blvd/Street 106, Phnom Penh, Cambodia

⁴Advisor, Japan Dredging and Reclamation Association
3-3-5 Akasaka, Minato-ku, Tokyo, 107-0052, Japan

Abstract: Inland waterway transport (IWT) via the Mekong River has an advantage over road transport in terms of shipping cost. In order to enhance the competitiveness of IWT, a field survey was carried out to identify issues which need to be addressed. The survey also included a night time border crossing by barge thanks to the cooperation of stakeholders in Cambodia and Vietnam. The survey results indicated that 24-hour border point operation along the river would increase transport capacity and provide access to mother container vessels calling at Southern Vietnamese ports. In addition, the simulation results of the container cargo assignment model show that the increase of barge size and 24-hours border point operation will enlarge the share of water transport. The improvements to the inland waterway system will create business opportunities for factories in Cambodia.

Keyword — Mekong River, inland waterway transport, container logistics, Cambodia, South Vietnam

1. INTRODUCTION

Inland waterway transport (IWT) has a cost advantage for long-distance transport over other transport means such as road and rail transport. For example, the distance between Shanghai and Chongqing/Luzhou is more than 2,000 km which means that IWT along the Yangtze (Chang) River is less expensive and more reliable than road/railway transport (Veenstra and Notteboom, 2011; Ozawa et al., 2010). On the other hand, the average distance of IWT in Europe is only around 280 km. At this distance, IWT in Europe does not have an advantage over road or railway transport, even though the cost of IWT is lower (Konings et al., 2010).

As the service distance between the ports of Phnom Penh (Cambodia) and Cai Mep (Vietnam) is around 374 km at the maximum, IWT via the Lower Mekong River has a clear advantage over road transport in terms of cost. In reality, approximately 23 % of all import/export laden containers of Cambodia were transported via Phnom Penh Port and the Mekong River in 2013, while 13 % of total export/import containers were transported by National Road No.1 (Suzuki et al., 2014; Shibasaki et al., 2014; rest of them were transported via the port of Sihanoukville, Cambodia). However, road transport between Phnom Penh and Ho Chi Minh (Vietnam) will be enhanced by the inauguration of the Tsubasa Bridge in April 2015 and future expressway development between Phnom Penh and Ho Chi Minh Cities. Accordingly, IWT also needs to be improved in order to remain cost-competitive.

The purpose of this paper is to identify obstacles and issues which need to be addressed for enhancing barge navigation along the Mekong River. To that end, a field survey including a border crossing at night was conducted in January 2015 with the support of the Ministry of Land, Infrastructure, Transport and Tourism (MLIT) of Japan. The authors focused on issues related to infrastructure, administration and operation regarding IWT and proposed measures to facilitate IWT between Cambodia and Vietnam.

The remainder of the paper is organized as follows. In Section 2, we position this paper against recent related literature. Section 3 presents the backgrounds and setting of the field survey. Section 4 presents the results of the field survey including trial navigation and observation at border point. Section 5 summarizes analyses and recommendations acquired from the field survey results. Section 6 presents an impact of the recommended policy by utilizing the route choice model that the authors developed. Section 7 presents a conclusion of the paper.

*Corresponding author's e-mail: t-shimada@ocdi.or.jp

2. LITERATURE REVIEWS

Although several papers on logistics environment in the Greater Mekong Subregion (GMS) have been recently published such as Goh and Ang (2000), Banomyong (2010), Sisovanna (2012), and Srivastava and Kumar (2012), most of them focus on land transport, not IWT. Some of such papers consider the competition among shipping routes in the GMS by comparative analysis (e.g., Hanaoka et al., 2014; Rudjanakanoknad and Limsathayurat, 2015), transport modelling (Shibasaki et al., 2007; Shibasaki et al., 2012; Kawasaki et al., 2015; Arunyanart et al., 2016), or economic modelling (Isono, 2010; Kumagai et al. 2013); however, they also usually focus on the road and maritime shipping, not including IWT. More than 20% of container cargo in Cambodia is transported by IWT and this is the second largest share behind Sihanoukville port. IWT is the one of important transport modes in Cambodia and efforts should be made to develop it further.

In Asian context, most of papers researching IWT focus on the Yangtze River in China such as Veenstra et al. (2008), Veenstra and Notteboom (2011), Yang et al. (2013), and Zheng and Yang (2016), since its cargo shipping amount is the largest among the world. Tuan (2011) and Utomo and Mateo-Babiano (2015) compare the feature of IWT in Southeast Asia including the Mekong River, mainly focusing in passenger transport. Gupta et al. (2002) structure the database of the Mekong River from a geomorphological aspect by utilizing satellite images. Manatunge et al. (1997) and Belgian Technical Corporation (2006) discuss the issues when a vessel navigates the Lower Mekong River and summarize the future prospects. This paper follows these works and focuses on recent issues related to infrastructure, administration and operation regarding IWT in the Mekong River between Cambodia and Vietnam from a viewpoint of cargo shipping.

Regarding the route choice or competition to include IWT in the GMS, Hanaoka (2013) describes and analyzes the competitive situation of the Cambodian ports including river port. Suzuki et al. (2014) compare IWT with the route to Vietnamese ports by trucks, while Shibasaki et al. (2014) four major shipping routes to/from Phnom Penh connecting gateway ports including IWT. ADB (2006) develops an incremental assignment model on the intermodal transport network including not only road and railways, but also water transport in the entire GMS. As well, JICA (2012; 2013) develop a logit model for route choice of Cambodian international containers including the Mekong River route. However, in most of these models, maritime shipping is not considered or simplified as a given condition. Shibasaki et al. (2014) develop a route choice model of international container cargo based on network assignment methodology including global maritime shipping network as well as regional hinterland shipping network including IWT in the Mekong River. This paper applies the model developed in Shibasaki et al. (2014) for measuring the impact of the policy that is recommended by the authors.

Numerous studies model the behavior of liner shipping companies, such as port-of-call selection, as recently reviewed by Christiansen et al. (2013), Meng et al. (2014), and Lee and Song (2016). Additionally, some models focus on the behavior of shippers, such as shipping route and port selection; for example, Bell et al. (2011) develop a frequency-based assignment model on an international container shipping network; Wang and Meng (2011) propose a probit model with a Monte Carlo simulation applied to the East Asian intermodal network. On a more global and practical level, mainly due to model applicability and data availability, a simpler network assignment model is often applied; for example, Fan et al. (2009; 2012) propose a port choice model of US cargo by cost minimization, to include both the land and maritime network on the North American continent with consideration of port congestion, although the maritime shipping network is extremely simplified; Tavasszy et al. (2011) develop a path size logit model to assign international cargo on a global scale, including both maritime and land shipping networks. ITF-OECD (2015) also develops a shortest path search model on a global intermodal network, even including air transport.

Moreover, several recent papers develop models to deal with the network design problem of international maritime container shipping, including an extensive intermodal shipping network such as East Asia (Shibasaki et al., 2010; Meng and Wang, 2011), Trans-Pacific (Shibasaki and Watanabe, 2012), and the Trans-Atlantic region (Iran et al., 2016). These models consider network design problems such as port-to-call from shipping company's viewpoint, as well as the port selection behavior for import/export of cargo owners. However, they are too complicated to apply to the entire global liner service network and ensure agreement with current records. Liu et al. (2014) develop a model to solve the network design problem of global international maritime container shipping with a combination of simple cost minimization models to identify the network and a logit model of port selection, but only focus on a specific shipping company without any consideration of congestion and agreement with the current situation. Wang et al. (2016) develop an intermodal network assignment model with consideration of distribution of cargo owners in the hinterland. Wang and Meng (2017) propose a discrete intermodal freight transportation network design as a mixed-integer nonlinear and non-convex problem. Such models based on new concepts are also in progress in empirical global scale analysis.

3. BACHGROUNDS AND DESIGN OF FIELD SURVEY

3.1 Survey Area and Navigation Routes

For a 102 km stretch between Phnom Penh and Cambodian-Vietnamese border, the bends of the river prevent the passage of vessels more than 110m in length. To travel from Phnom Penh to Cai Mep and other ports in South Vietnam, a vessel must currently take the Mekong route both in Cambodia and in Vietnam. There are 2 routes in the Mekong River system for vessel navigation: the first one is to pass the Cho Gao Canal and the second one is to pass the river mouth of the Mekong and the South China sea (see Figure1). However, the Cho Gao Canal is shallow and narrow, and has a under clearance limitation due to bridges and electric wires. Meanwhile, the river mouth is even shallower; the current depth at low tide is only around 2m, necessitating that vessels wait for high tide in order to pass. In addition, small vessels are affected by strong winds and high waves during the monsoon season.

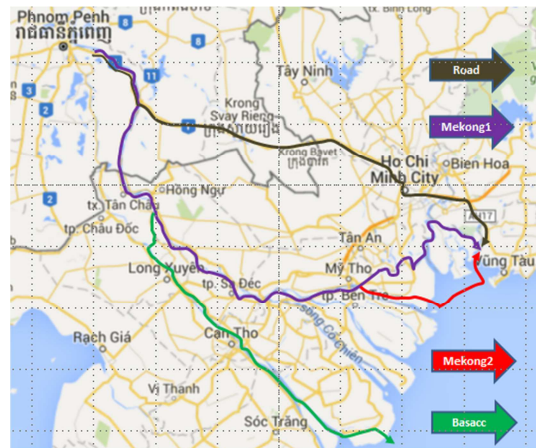

Figure 1. Survey area and navigation route
 Source: the authors based on Google map 2016

3.2 Current Traffic Volumes and Advantages of IWT

Laden containers are transported between Phnom Penh and Ho Chi Minh via IWT along the Mekong River and road transport. In 2015, the volume of laden export containers via IWT totaled 59,000 TEUs, which is larger than the volume of laden import containers (46,000 TEUs) and significantly larger than the 24,000 TEUs of laden export containers transported by road. Accordingly, the authors focused on the route of laden export containers for the trial navigation (see Figure 2).

The authors conducted its survey in January 2015 when the depth of the river is shallow in order to focus on typical problems associated with barge navigation during the dry season. (The depth of the river during the dry season is shallower than during the rainy season which leads to problems such as long waiting times). Another reason for selecting January to conduct the trial navigation was that the volume of the laden export containers at this time represents the average value (see Figure 3).

IWT via the Mekong River has several advantages compared to road transport. For example, one barge can transport more than 100 TEU containers per voyage which makes IWT more economical than road transport. The cost of transporting cargo via IWT from Phnom Penh Port to Cat Lai Port in Ho Chi Minh City is half that by road transport. Moreover, IWT is more environmentally friendly than truck transport. Even during the dry season, the water level of the lower and middle sections of the Mekong River is sufficient for IWT. Therefore, shipping companies can offer regular and reliable transport services all year round.

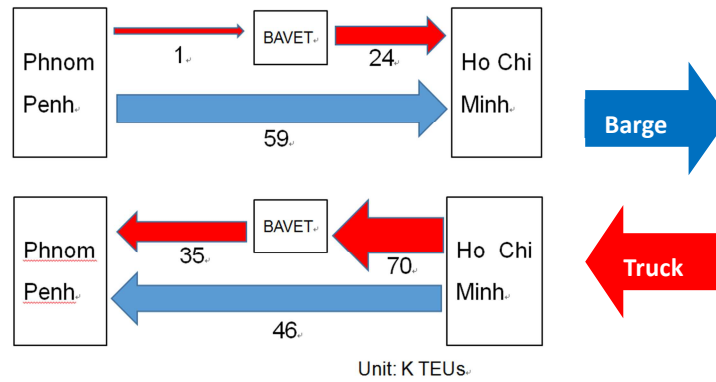

Figure 2. Annual movement of laden containers in 2015 (Source: the authors)

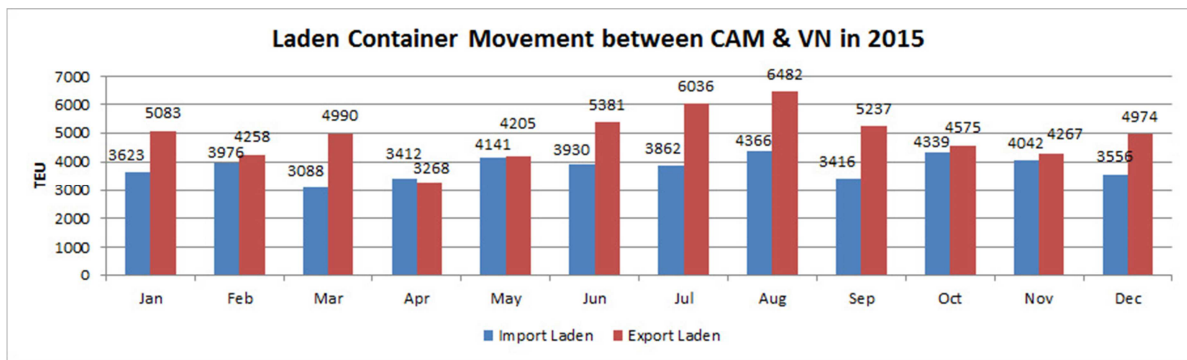

Figure 3. Laden container throughput in Phnom Penh port in 2015 (Source: the authors)

3.3 Contents of Surveys

The authors boarded barge vessels (see Table 1) and conducted the following surveys:

- a. present situation of the administrative procedures at the river border,
- b. present situation of the transport infrastructure for navigation through the passage of the Mekong River, and
- c. present situation of the aids to navigation.

Both the positive and negative aspects of the current situation are evaluated, focusing particularly on the flexibility of operations and procedures at the borders of both countries.

Table 1. Trial navigation case

Case	Phnom Penh	Border	Cai Mep	Route
Case-1 Sovereign 96 TEUs	0:50 on 18th Jan. 2015	5:20 -7:35 on 18th Jan. 2015	14:25 on 19th Jan.2015	Sea 344km: 37h35m TCIT
Case-2 Cypress 128 TEUS	2:00 on 18th Jan. 2015	8:00 -10:00 on 18th Jan. 2015	18:15 on 19th Jan. 2015	Canal 371km: 40h15m SPCT/TCIT
Case-3 Gemadep 112 TEUS	12:30on 18th Jan. 2015	19:00- 20:30 on 18th Jan. 2015	5:20 on 20th Jan. 2015	Canal, Night 374km: 40h50m, CMIT

source: the authors

4. SURVEY RESULTS

4.1 Trail Navigation

4.1.1 Case 1: River mouth route

Golden Fortune 1 of Sovereign arrived at the border early in the morning and waited for 2 hours while border-crossing procedures were followed. This barge cannot pass the Cho Gao Canal due to draft and height limitations and must instead pass the river mouth of the Mekong (see Figure 4). However, the river mouth is very shallow (around 2.0 m at low tide). Therefore, it was necessary to wait 11 hours at My Tho for high tide. In the river mouth of the Mekong, there were many fishing nets near the navigation passage (see Figure 5) which made it necessary for the vessel to decrease her speed. Total distance and time of the voyage (from Phnom Penh Port to Cai Mep Port) was 344 km and 37 hours and 35 minutes, respectively. The average vessel speed was 14km/h excluding waiting time (13 hours) (see Table 2).

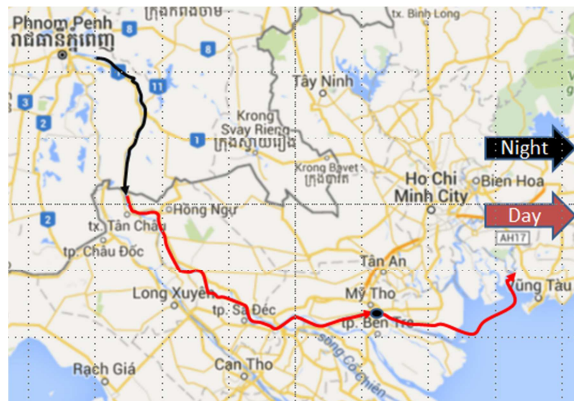

Figure 4. Route of Sovereign barge (Case 1) (source: the authors based on Google map 2016)

Table 2. Timetable of sovereign barge (Case 1)

Check Point	Distance	Time	Hours
Departure from Phnom Penh Port	0 km	At 0:50 AM 18 Jan. Sunday	0:00
Arrival at border	72 km	At 5:30 AM 18 Jan. Sunday	4:40
Departure from the border		At 7:35 AM 18 Jan. Sunday	6:45
Arrival at My Tho	216 km	At 19:15 PM 18 Jan. Sunday	18:25
Departure from My Tho		At 6:30 AM 19 Jan. Monday	29:40
Arrival at Cai Mep Port (TCIT)	344 km	At 14:25 PM 19 Jan. Monday	37:35

source: the authors



Figure 5. Fishing nets in the mouth of the Mekong (source: the authors)

4.1.2 Case 2: Cho Gao Canal route

The barge of New Port Cypress Co. Ltd arrived at the border in the morning and waited 2 hours while border-crossing procedures were carried out. She used the Cho Gao Canal route (see Figure 6) because she had to discharge containers at the Saigon Premium Container Port (SPCT) on the Soai Rap River. The actual draft of the barge is around 2.2 m but it had to be adjusted by charging ballast water in order to satisfy under clearance restrictions of bridges over the canal (see Figure7). Handling works were carried out at SPCT even during the lunch break but documentation works were discontinued. Therefore, it was necessary to stay at the terminal for 2 hours. Total distance and time of the voyage was 371 km and 40 hours and 15 minutes, respectively (see Table 3). The average vessel speed was 10.3 km/h excluding waiting time (4 hours).

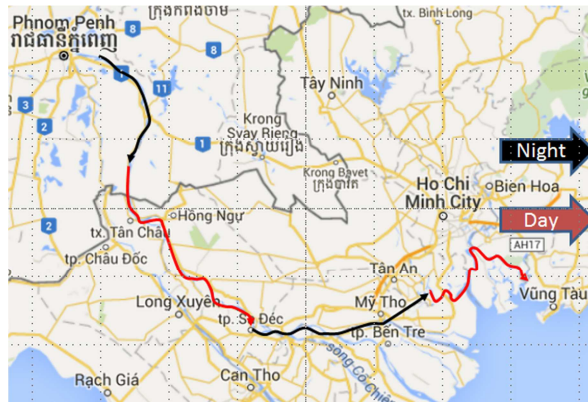

Figure 6. Route of Cypress barge (Case 2) (source: the authors based on Google map 2016)

Table 3. Timetable of Cypress barge (Case 2)

Check Point	Distance	Time	Hours
Departure from Phnom Penh Port	0 km	At 2:00 AM 18 Jan. Sunday	0
Arrival at border	72 km	At 8:00 AM 18 Jan. Sunday	6:00
Departure from the border		At 10:00 AM 18 Jan Sunday	8:00
Arrival at SPCT	325 km	At 11:10 AM 19 Jan Monday	33:10
Departure from SPCT		At 13:10 PM 19 Jan Monday	35:10
Arrival at Cai Mep Port (CMIT)	371 km	At 18:15 PM 19 Jan. Monday	40:15

source: the authors

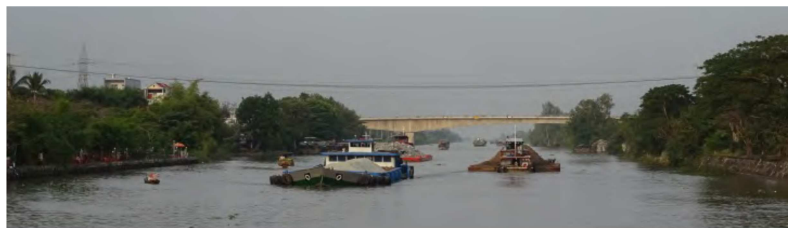

Figure 7. Electric cable and bridge above Cho Gao canal (source: the authors)

4.1.3 Case 3: Cho Gao Canal route and border point at night

The barge of Gemadep Co. Ltd departed from Phnom Penh New Container Terminal in the afternoon on 18th January. River Border Administration closes at 17:00 in the afternoon. As mentioned in the previous cases, it takes two hours for administration procedures. Barges which arrive at the border late in the afternoon typically must wait at the border until the next day when border operations resume. However, thanks to the cooperation of relevant authorities of both countries, administration works were able to be carried out during the evening for this field survey. The barge arrived at the border of Cambodia at 19:00 (see Table 4 and Figure 8) and border-crossing

procedures on the Vietnamese side were completed by 20:30. The barge had to reduce speed before arriving at the Cho Gao Canal in order to pass under bridges during high tide. Total distance and time of the voyage was 374 km and 40 hours and 50 minutes, respectively (see Table 4). The average vessel speed was 9.6 km/h excluding waiting time at the border (1.5hrs).

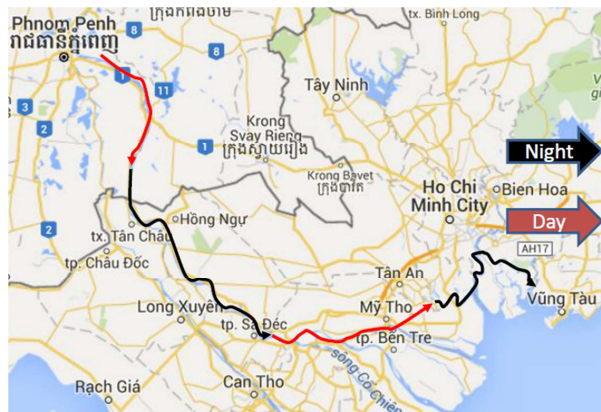

Figure 8. Route of Gemadept barge (Case 3) (source: the authors based on Google map 2016)

Table 4. Time table of Gemadept barge (Case 3)

Check Point	Distance	Time	Hours
Departure from Phnom Penh Port	0 km	At 12:30 PM 18 Jan. Sunday	0
Arrival at border	72 km	At 19:00 PM 18 Jan Sunday	6:30
Departure from the border	72 km	At 20:30 PM 18 Jan. Sunday	8:00
Arrival at Cho Gao Canal	255 km	At 15:40 PM 19 Jan. Monday	27:10
Arrive at Soi Rap River	306 km	At 22:05 PM 19 Jan. Monday	31:40
Arrival at Cai Mep Port (CMT)	374 km	At 5:20 PM 20 Jan. Tuesday	40:50

source: the authors



Figure 9. KAMSAB office at Cambodia border point (source: the authors)



Figure 10. Documents required by Cambodian authorities (source: the authors)

4.2 Border Point Survey

4.2.1 Required documents

Various documents are required by Customs, Quarantine and Immigration offices at borders. The Cambodian customs office, in particular, requires many kinds of documents compared to the Vietnamese side (see Figure 10 and Table 5). Simplification of border protocols is necessary to enhance container transit.

Table 5. Documents required by ICQ offices at the border

Cambodian Side	Vietnamese Side
Custom Office	Custom Office
1. Invoice	1. Summary Manifest
2. Packing List	2. Container Loading List
3. Joint Inspection Report	3. General Declaration
4. Customs Declaration	4. Crew's effective Declaration
5. Bill of Lading	5. Ship's Store Declaration D-49
6. Cargo Manifest	6. Cargo Declaration
7. Crew's Personal effects	7. Dangerous Ground Manifest
8. Provision Store List	8. Crew List
9. Bonded Store List	9. Bill of Lading
10. Ship's Store List	
11. Dock Store List	
12. Engine Store List	
13. Declaration of Departure	
Immigration Office	Immigration Office
1. Discharging List	1. Discharging List
2. Container Loading List	2. Container Loading List
3. Declaration of Departure	3. Declaration of Departure
4. Crew List	4. Crew List
Quarantine Office	Quarantine Office
1. Declaration Ship Arrival	1. Declaration Ship Arrival
2. Declaration of Health for Out Bound Vessel	2. Declaration of Health for Out Bound Vessel
3. Report of Water Take On Board	3. Report of Water Take On Board
4. Crew List	4. Crew List
5. Maritime Declaration of Health	5. Maritime Declaration of Health

source: the authors

4.2.2 Virtual closing of border points during the evening

If a barge arrives at the border late in the afternoon and cannot complete the procedures within the border office operation hours, the barge must wait until operations resume the next day. The checking offices of both sides recently introduced a border-crossing protocol at night on a request basis but it has proven difficult to implement. Therefore, barges still generally anchor in the middle of the river until operations resume in the morning.

4.2.3 One-Stop service at the border point on the Vietnamese side

There is a border complex station at the border point of the Vietnamese side which provides one-stop border clearance service (see Figure 11). On the Cambodian side, however, relevant offices are independent from one another which results in staff from the various offices bringing in documents for border clearance on motorbikes.

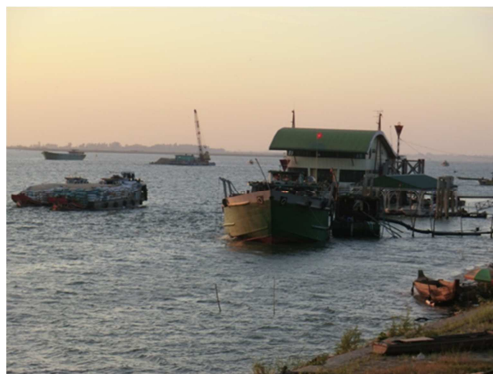

Figure 11. Border complex station at the border of Vietnam (source: the authors)

5. ANALYSIS OF FIELD SURVEY FINDINGS AND RECOMMENDATIONS

5.1 Administrative Procedures at the Border

5.1.1 Independent border offices on the Cambodian side

Chau Dac, the Mekong River border point on the Vietnamese side, has introduced a single-stop service in which all authorities concerned are housed in the same administration station building. At Khaorm Samnor on the Cambodian side, however, authorities work in small independent offices on the river side. Staff of KAMSAB must visit each office for documentation procedures. One-stop service should be introduced on the Cambodian side.

5.1.2 Border-crossing documents in Cambodia

The amount of documents required in Cambodian side for crossing the border is much greater than the Vietnamese side. Accordingly, documentation procedures should be simplified in the Cambodian side. The authors acknowledge, however, that there may be some political obstacles to decreasing the amount of documentation. Electric Data Interchange (EDI) system is recommended to be introduced to both countries. The introduction of electronic data interchange (EDI) makes the cross border procedure simpler in the Mekong container transit. It makes the Mekong container transit simpler to introduce EDI system for the cross border procedure.

5.1.3 Effect of 24-hour operation at the border point

If the border point were open 24 hours with EDI system at the border, the duration of one round trip might be reduced from 7 days to 5 days (see Table 6). This would allow barge rotation times to be increased. 24-hour border point operation along the river would enable barges access stronger to mother vessels in Cai Mep and other ports in the south of Vietnam. As a result, factories in and around Phnom Penh City could enjoy enhanced business opportunities.

Table 6. Current and proposed navigation time in the Mekong River

	Current Days	24-hr Op. Days
Container Unloading in Phnom Penh	0.5	0.3
Container Loading in Phnom Penh	0.5	0.3
Stream Down	1.7	1.2
Container Unloading in Vietnamese port	0.5	0.3
Container Loading in Vietnamese port	0.5	0.3
Stream Up	2.3	1.7
Adjustment & Maintenance	1.0	1.0
Total	7.0	5.1

source: the authors

5.2 Infrastructure Issues for IWT

5.2.1 Mekong river mouth

There are two critical issues of IWT on the Mekong. The first one is the shallow river mouth of the Mekong. The river is 2.0 m during low tide with many fishing nets installed throughout the river mouth area. Barges which traverse the river mouth to Cai Mep Port have to wait for high tide. In the field survey, the Sovereign Barge was forced to wait for around 11 hours. In the monsoon season, barges are affected by wind and wave with containers occasionally falling into the sea. It is also difficult to maintain the canal depth in the river mouth as sand drifts back to the canal due to strong waves.

5.2.2 Cho Gao canal development

The second issue is the narrow Cho Gao Canal which lies between the Mekong and the Soai Rap Rivers. This canal is a by-pass from the Mekong River to ports in Ho Chi Minh City but it is narrow and vessels are subject to under clearance restrictions. Barges should make their speed down to pass this canal, particularly at night. Vietnam Inland Waterway Agency intends to improve canal conditions under a Public Private Participation scheme. This project should be carried out as soon as possible.

5.2.3 Vam Nao pass development

By using the Bassac River in Vietnam where 5,000 DWT ocean-going vessels can navigate even in low water season, container transit volumes can be increased. For this to become a reality, it is necessary to develop the Vam Nao Pass which connects the Mekong River with the Bassac River near the border in Vietnam. Now the government of Vietnam focuses on the development of Quan Chanh Bo canal in the river mouth of Hao (Bassac). After the completion of this canal, both countries are considered to start the discussion to excavate Vam Nao Pass.

6. POLICY SIMULATION USING THE CARGO FLOW MODEL

Based on findings in the previous section, the authors examined the effect of 24-hour operations at the border point using the large-scale intermodal container cargo assignment model (Shibasaki et al., 2017). The model is the network assignment model including global maritime shipping network and a regional hinterland shipping network. The model has two layers as shown in Figure 12; in the upper layer, a stochastic network assignment methodology is applied on the intermodal shipping super-network. In the lower layer, a user equilibrium assignment methodology with vessel capacity constraint is applied on the global maritime shipping network, whereas a shortest path search is applied on the regional hinterland shipping network, respectively. There are two reasons why the model is divided into two layers; simultaneous consideration of stochastic approach and capacity constraint without any biased assignment results due to the independence of irrelevant alternatives, and consideration of the difference between shipping cost and freight charge, which is defined on a path, not a link basis, on the maritime container shipping market.

Shibasaki et al. (2014) applies such model to the lower Mekong region focusing in international container cargo to/from Cambodia. It also includes IWT in the Mekong River by adding a few shipping links in the global maritime shipping network.

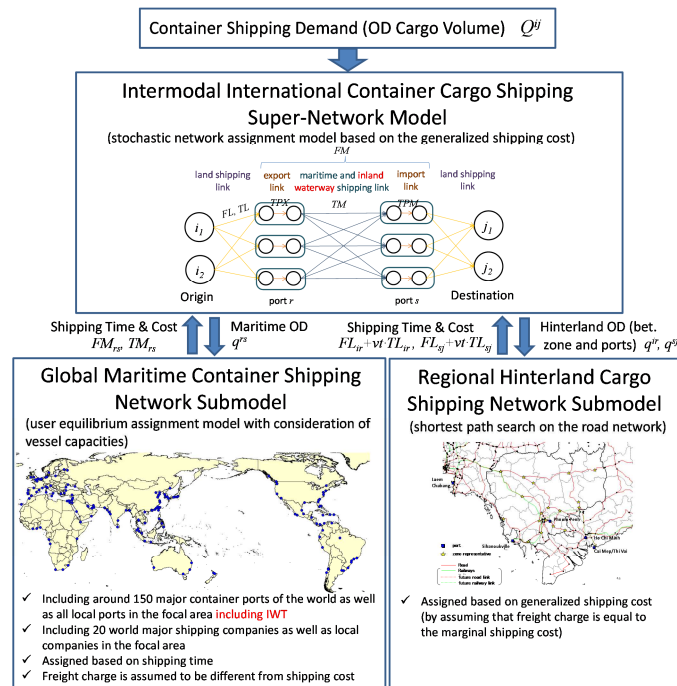

Figure 12. Intermodal network of international container cargo of the assignment model (source: Shibasaki et al., 2017)

6.1 Model Structure

The model is developed from a viewpoint of cargo owners or shippers. Each shipper is assumed to choose the ports to be used for export and import, given the freight charges for maritime and land transport, and shipping time, on the intermodal container shipping network.

6.1.1 Upper layer model

A stochastic assignment model that can consider the influence of unobservable elements from the model developer is applied to describe the behaviour of shippers for port choice in the upper layer of the model. When a cargo shipping demand (TEU/year), Q^{ij} , from region i to region j , and generalized shipping cost (US\$/TEU), G_b^{ij} , of path b from region i to region j , are given, cargo volume, F_b^{ij} , on a path b from region i to region j is formulated as follows, if an error term is assumed to follow Gumbel distribution with distribution parameter θ , which is estimated to best fit the estimated export and import container throughput of each port to the actual throughput.

$$F_b^{ij} = Q^{ij} \cdot \frac{\exp(-\theta \cdot G_b^{ij})}{\exp(-\theta \cdot G_b^{ij}) + \sum_{b' \in H^{ij}} \exp(-\theta \cdot G_{b'}^{ij})}, \quad (1)$$

where H^{ij} is the path choice set. The generalized shipping cost, G_b^{ij} , consists of monetary cost and time cost as follows.

$$G_b^{ij} = (FL_{ir} + FM_{rs} + FL_{sj}) + \nu \cdot (TL_{ir} + TPX_r + TM_{rs} + TPM_s + TL_{sj}), \quad \forall r \in h, \forall s \in h \quad (2)$$

where ν is value of time for shipper (US\$/TEU/hour); FL_{ir} , FL_{sj} freight charge (US\$/TEU) of land shipping from origin i to port r and from port s to destination j ; FM_{rs} ocean freight charge from port r to port s (US\$/TEU) including inland waterway shipping and port charges; TL_{ir} , TL_{sj} land shipping time (hours) from origin i to port r and from port s to destination j ; TPX_r , TPM_s lead time (hours) when exporting in port r and when importing in port s ; and TM_{rs} maritime and inland waterway shipping time (hours) from port r to port s .

The ocean freight charge, FM_{rs} , and maritime shipping time, TM_{rs} , are acquired from calculation results of the maritime shipping submodel in the lower layer, while the freight charge, FL_{ir} and FL_{sj} , and shipping time, TL_{ir} and TL_{sj} , of hinterland shipping are acquired from the hinterland shipping submodel.

A cargo flow of each link in this model represents inputs (i.e., cargo shipping demand) of the submodels in the lower layer, namely,

$$q^{rs} = x_{rs}, \quad (3)$$

$$q^{ir} = x_{ir}, q^{sj} = x_{sj}, \quad (4)$$

where q^{rs} is the maritime cargo shipping demand (TEU/year) from export port r to import port s ; q^{ir} , q^{sj} are the hinterland cargo shipping demand (TEU/year) from origin i to export port r and import port s to destination j , respectively; x_{rs} is the cargo flow (TEU/year) of maritime shipping link; and x_{ir} , x_{sj} are cargo flows (TEU/year) of the hinterland shipping link.

6.1.2 Lower layer model: global maritime shipping submodel

The maritime and inland waterway shipping time, TM_{rs} , in Equation (2) is estimated from the output of the global maritime shipping submodel. The model is defined as a problem allocating container cargo to the global liner shipping network based on containership movement data. Each liner shipping network is structured as shown in Figure 13. Each container of the shipper chooses a link from the origin node (O node) of an export port to the destination node (D node) of an import port. In this submodel, every container of each origin-destination (OD) pair is assumed to choose a route to minimize total transit time. The shipper chooses a carrier considering only transit

time, not freight charge. This assumption is based on the idea that the international maritime container shipping market is oligopolistic, but a freight charge for an OD pair is the same among carriers if the service is provided and utilized. Since vessels for each service have their own capacities, there is diseconomy of scale by concentrating onto a specific service. Therefore, the congestion of the link is considered, and a user equilibrium (UE) assignment is applied as network assignment methodology.

$$\min_x z(x) = \sum_{a \in \mathcal{A}} \int_0^{x_a} t(x_a) dx, \tag{5}$$

$$s.t. x_a = \sum_{(r,s) \in R \times S} \sum_{k \in K^{rs}} \delta_{a,k}^{rs} \cdot f_k^{rs}, \forall a, \tag{6}$$

$$\sum_{k \in K^{rs}} f_k^{rs} - q^{rs} = 0, \forall r, s, \text{ and} \tag{7}$$

$$f_k^{rs} \geq 0, \forall k, r, s, \tag{8}$$

where a is the link; \mathcal{A} the set of links; x_a the flow of the link a ; $t_a(\cdot)$ the cost function of link a ; $z(\cdot)$ the objective function; r the origin; s the destination; R the set of the export port; S the set of the import port; k the path; K^{rs} the set of path for OD pair rs ; $\delta_{a,k}^{rs}$ the Kronecker delta; and f_k^{rs} the flow on path k . Kronecker delta, $\delta_{a,k}^{rs}$, is written as

$$\delta_{a,k}^{rs} = \begin{cases} 1 & \text{if } a \in k \\ 0 & \text{if } a \notin k \end{cases}. \tag{9}$$

By the UE assignment calculation according to the algorithm shown by Sheffi (1985), maritime and inland waterway shipping time is estimated.

A cost function of each link is shown as follows. Only navigation link has a flow-dependent cost function.

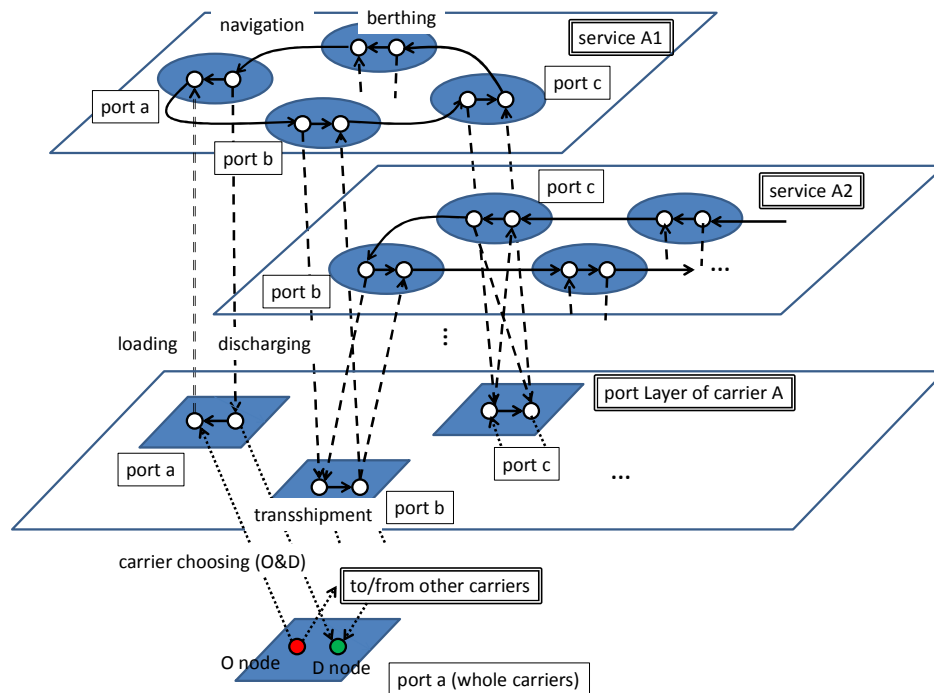

Figure 13. Network structure of a maritime shipping submodel (source: Shibasaki et al., 2017)

A navigation link connects each port by each liner service on the sea. The link cost includes shipping time and congestion due to the capacity constraints of a vessel.

$$t_n(x_a) = \left(\frac{l_a}{v_a} + \gamma_a^s \cdot TS + \gamma_a^p \cdot TP \right) + TW_{a'} \cdot b1 \left(\frac{x_a}{cap_a \cdot freq_a} \right)^{b2}, \quad (10)$$

where t_n is the shipping time (hour) of the navigation link a ; l_a the distance (nautical mile) of the link; v_a the vessel speed (knot) of the link; γ_a^s, γ_a^p a dummy variable on the Suez and Panama Canal transit (1 if link a passes through the Suez/Panama Canal and 0 otherwise); TS, TP the additional time for Suez and Panama Canal transit (set at 24 hours respectively); a' the loading link in the departure port of the navigation link a ; $TW_{a'}$ the expected waiting time (hour) for the loading in the loading link a' ; cap_a the average vessel capacity (TEU/vessel) of the service for each shipping company; $freq_a$ the service frequency (vessels/year); and $b1, b2$ the parameters related to the congestion.

The first term of the equation is the shipping time without any congestion, including the transit time of the Suez and Panama Canal. The second term represents the delayed time due to the congestion. The delayed time is obtained by multiplying the waiting time for the loading as shown in Equation (11) by the congestion function, which may have some relationship with the load factor, $x_a/(cap_a \cdot freq_a)$, which is acquired by dividing annual link flow, x_a , by annual capacity of vessel of the link, $cap_a \cdot freq_a$.

$$TW_{a'} = \frac{1}{2} \cdot \frac{YH}{freq_a}, \quad (11)$$

where YH is the constant for conversion from one year to hours (52 (weeks/year) \times 7(days/week) \times 24(hours/day) = 8,736 (hours/year)). The term $(YH/freq_a)$ represents the duration in hours for each vessel of the service. The expected waiting time is assumed to be half of that value.

A loading link connects from a port layer to each liner service in each port by each shipping company. The link cost t_l (hour) of a loading link a is defined as the sum of the loading time and the expected waiting time for departure, related to the frequency of each service.

$$t_l(x_a) = TL_a + TW_{a'}, \quad (12)$$

where TL_a is the loading time (hour) of the loading link a .

A discharging link connects from each liner service to a port layer in each port by each shipping company, inversely with the loading link. An anchoring link represents each liner service in the port for a container which is on board a vessel (i.e., neither discharged nor loaded). A transshipment link will be passed if a container is transshipped from one service to another.

$$t_d(x_a) = TD_a, \quad (13)$$

$$t_b(x_a) = TB_a, \text{ and} \quad (14)$$

$$t_r(x_a) = TR_a, \quad (15)$$

where t_d is the time of the discharging link; t_b the time of the berthing link; t_r the time of the transshipment link; TD_a the discharging time (hour) of the discharging link a ; and TB_a the berthing time (hour) of the berthing link a .

In this model, container shipping utilizing multiple carriers is not allowed. In other words, each container should be transported by only one carrier. Therefore, the carrier choosing link is to be set to avoid transshipment of the container between carriers. The link cost, t_c (hour), is defined as

$$t_c(x_a) = SSN, \quad (16)$$

where SSN is a sufficiently small number (actually, set at 0.01 (hour)), since transshipment between carriers is impossible by setting the link, irrespective of the link cost.

The ocean freight charge (including inland waterway shipping) on each maritime and inland waterway shipping link, FM_{rs} , in Equation (2) provided by carrier may be sometimes different from the monetary cost of the route for the carrier, reflecting the situation of market competition. Therefore, in this model, freight charge is estimated as follows, from the path cost calculated from the maritime and inland waterway shipping network which is developed for the above shipping time calculation.

Since individual maritime container shipping market connecting specific export and import port may be easy to enter and leave for the shipping companies, especially for those which already operate container vessels in the region in question, the ocean freight charge should be equal or larger than the average shipping cost for the shipping companies that currently participate the market in question. Therefore, an initial ocean freight charge, $FM_{rs}^{(0)}$, in each market from export port r to import port s is calculated as

$$FM_{rs}^{(0)} = \max_{g \in G} AC_g^{rs}, \quad (17)$$

where AC_g^{rs} is average cost of shipping company g from export port r to import port s ; and G set of shipping company.

Given that the total shipping cost for each shipping company is not changed during the iterative calculation of the entire model since any service network of maritime shipping is not changed, the ocean freight charge during the iterative calculation is assumed to be only changed in proportion with the change of shipping demand of each market as follows as

$$FM_{rs}^{(n)} = \left\{ \frac{q_{rs}^{(n)}}{q_{rs}^{(n-1)}} \right\}^\gamma \cdot FM_{rs}^{(n-1)} \quad (18)$$

where $FM_{rs}^{(n)}$ is ocean freight charge in n th iterative calculation; $q_{rs}^{(n)}$ maritime container shipping demand from export port r to import port s ; and γ parameters for price elasticity of demand for international container cargo.

6.1.3 Lower layer model: regional hinterland shipping submodel

The shipping time, TL_{ir} and TL_{js} and the freight charge, FL_{ir} and FL_{js} in Equation (2) in the hinterland shipping link, are defined as sum of time or cost for driving and border-crossing, respectively. In addition, the freight charge can approximate the shipping cost, since the truck industry in this area is sufficiently competitive to be able to assume the perfect market competition. Therefore,

$$TL_{ir} = TD_{ir} + \lambda^l \cdot TB_{ir}, \quad TL_{js} = TD_{js} + \lambda^l \cdot TB_{js}, \quad \text{and} \quad (19)$$

$$FL_{ir} = CD_{ir} + \lambda^l \cdot CB_{ir}, \quad FL_{js} = CD_{js} + \lambda^l \cdot CB_{js}, \quad (20)$$

where TD_{ir} , TD_{js} are driving time (hour) of the land shipping link; CD_{ir} , CD_{js} driving cost (US\$/TEU) of the land shipping link; TB_{ir} , TB_{js} border-crossing time (hour) of the land shipping link; CB_{ir} , CB_{js} border-crossing cost (US\$/TEU) of the land shipping link; and λ^l coefficient on bonded transport for land shipping, λ^l is an adjustment unknown parameter as well as λ^m in the inland waterway shipping, which is included in average shipping cost, AC_g^{rs} , of maritime and inland waterway shipping. The driving time, TD_{ir} , TD_{js} and cost, CD_{ir} , CD_{js} are calculated from the shortest path search based on the land shipping network. The border-crossing time, TB_{ir} , TB_{js} and cost, CB_{ir} , CB_{js} are acquired from the summation of the time and cost respectively for “documents preparation” and “customs clearance and technical control” on the Doing-Business website provided by the World Bank.

6.2 Simulation Results

The model includes 156 major container ports where throughput was more than 500,000 TEU in 2010, as well as two Cambodian ports (Sihanoukville and Phnom Penh) and two neighboring countries' ports (Songkhla in Thailand and Kuantan in Malaysia) as shown in Figure 14. The liner shipping network all over the world is developed by the

MDS database (as of May 2010), which was provided by MDS Transmodal Inc., including name of liner service, operators and slot-chartered companies, port list to call with order, vessel speed, vessel capacity, and frequency for each service. Also, one hypothetically service is added in the Mekong River which calls at Phnom Penh, Cai Mep, and Ho Chi Minh City with 15 services per week operated by a vessel with capacity of 82 TEU. The land shipping network is only considered in Cambodia and neighbouring countries, which is structured based on Shibasaki et al. (2012). Note any railway links as well as future road links are not included this time due to lack of data. Detail settings of parameters included in shipping cost functions as well as lead time in each port, TPX_r and TPM_r , in Equation (2) are described in Shibasaki et al. (2017) and Shibasaki et al. (2014). Parameters set by each port in Cambodia and neighbor countries are shown in Table 7, as an example.

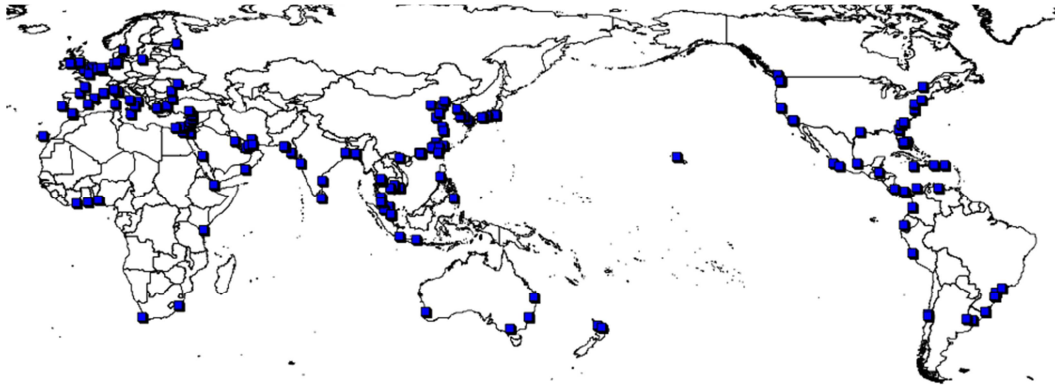

Figure 14. Container ports included in the model (source: Shibasaki et al., 2014)

Table 7. Settings of level of service in the selected ports (source: Shibasaki et al., 2014)

Port			Lead Time (Export) TPX_r	Lead Time (Import) TPM_r	Transshipment Time TR_r	Container Handling Charge (Export)	Container Handling Charge (Import)
No.	Port Name	Country	(hours)	(hours)	(hours)	(US\$/TEU)	(US\$/TEU)
30	Ho Chi Minh	Vietnam	72	96	48	150	175
31	Cai Mep/Thi Vai	Vietnam	72	96	24	150	175
311	Phnom Penh	Cambodia	72	96	48	100	225
312	Sihanoukville	Cambodia	48	48	48	100	225
32	Laem Chabang	Thailand	72	48	24	160	160
33	Bangkok	Thailand	72	48	24	160	160
331	Songkhla	Thailand	72	48	24	160	160
332	Kuantan	Malaysia	48	48	48	120	120
35	Tanjung Pelepas	Malaysia	48	48	12	120	120
36	Klang	Malaysia	48	48	24	120	120
38	Singapore	Singapore	24	24	12	150	150

The regional and maritime shipping demand of container cargo, Q_{ij} and $qrs(0)$ (which is utilized for initial calculation), are estimated based on a container OD cargo between more than 100 countries or regions in a TEU-basis provided by IHS Inc. as the World Trade Service (WTS) database. Since the container cargo to/from Cambodia is integrated as “Other Asia” in the WTS database with Myanmar, Lao DPR, Brunei Darussalam, Mongolia, North Korea, and Papua New Guinea, it is divided by utilizing the UN comtrade data, although it is on a value-basis data. Once the OD matrix is aggregated into less than 50 countries/regions due to consideration of international coverage and duplication of hinterland, it is divided again into a port-basis according to the port’s share of export and import container cargo throughput for the aggregated region, except for the Cambodian cargo which explicitly considers the hinterland shipping. The Cambodian cargo is divided into 24 provinces according to the amount of sales for each province, which is considered to most represent a regional economy among the available data.

The first two bars in Figure 15 show the observed shares and those estimated by the developed model of each route (or gateway port) for Cambodian international laden export and import containers. Note that the observed share of Laem Chabang port is not known and that the estimated shares shown in Figure 15 are slightly different from the results obtained by Shibasaki et al. (2014) due to a slight revision in the road network condition.

In the following simulation, the authors assume that a barge can complete a round-trip between Phnom Penh Port and South Vietnamese ports (including Ho Chi Minh and Cai Mep) in five days (as shown in Table 6) if 24-hour border operations are introduced (this is referred to as Scenario 1 in Figure 15). Since a barge currently requires seven days to make the same round-trip (Scenario 0), shipping costs can be reduced (by 5/7 of the current cost). To further optimize IWT, it is also assumed that the current barge size can be doubled (i.e. to 170 TEU) without upgrading current infrastructure. The changes in the road network from 2010 to 2016 including the opening of the Neak Loeng Bridge (across Mekong River), improvement works of Cambodian NH1 road from PP City to PP new port, the truck ban during the daytime in PP City, the partial opening of PP Ring Road No. 2, and the partial opening of the expressway from Ho Chi Ming City to Cai Mep port are considered in Scenario 0 and Scenario 1. In other words, the slight differences in the shares of each gateway port between those estimated by the model and those of Scenario 0 shown in Figure 15 are due to these changes in road conditions.

It is also noteworthy that export containers are forecast to significantly increase at Phnom Penh Port in Scenario 1 while its share of import containers will only marginally increase. This suggests that the advantage of inland waterway shipping for export cargo may become more pronounced, and thus the gap in the shares of export and import containers would be expected to increase.

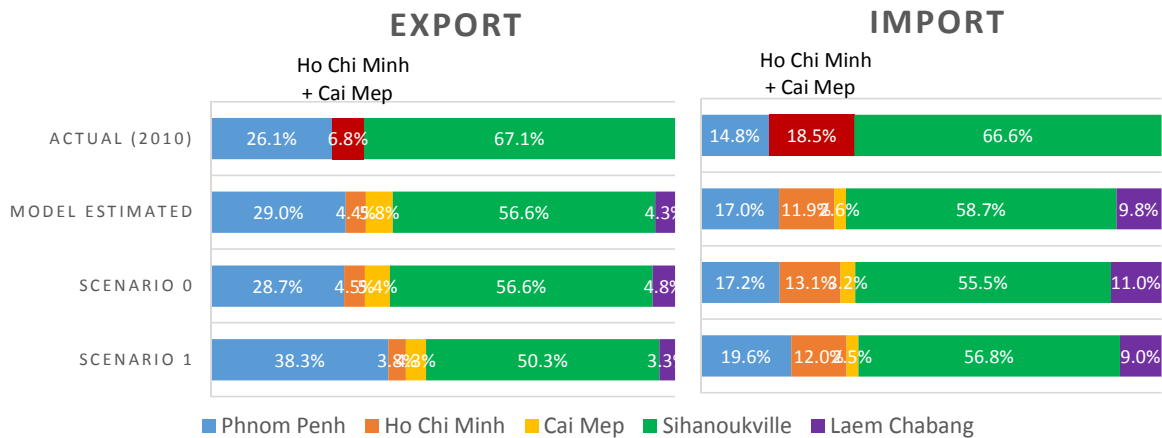

Figure 15. Estimated shares of Cambodian laden containers by gateway port (based on

7. CONCLUSION

This paper proposed ways to increase the competitiveness of IWT based on a survey of the actual transport conditions and border-crossing procedures between Cambodia and Vietnam. Through this survey, several administrative and physical issues were clarified.

The survey revealed that 24-hour border point operation along the river would enable barges access stronger to mother vessels at Cai Mep and other ports in the south of Vietnam. One of the administrative issues which need to be addressed is the excessive amount of documents which has to be submitted as part of border-crossing procedures, especially on the Cambodian side. The authors recommend that documentation works be simplified. Vietnam and Cambodia have made an agreement on the facilitation of IWT in 2008 including the utilization of ports in both countries in the Mekong and the facilitation of border crossing procedures. However, this facilitation has not been realized actually. The government of Cambodia examines to introduce port EDI up to 2018. IWT would change drastically, if EDI system is introduced to the procedures in the ports and the river border in the Mekong.

Once transport conditions of the Cho Gao Canal are improved, the transport of cargo along the Mekong River will become faster and volumes will increase. In addition, the simulation conducted by the authors indicated that the share of IWT will increase.

It is hoped these findings will assist both Cambodia and Vietnam in implementing measures necessary to increase the competitiveness of Mekong IWT.

REFERENCES

1. Arunyanart, S., Ohmori, S., Yoshimoto, K. (2016). Selection of export route option in GMS region: recommendation for current situation. *Journal of Japan Industrial Management Association*, 67: 193–201.
2. Asian Development Bank (ADB) (2006). *GMS transport sector strategy study: final report*.
3. Banomyong, R. (2010). *Logistics challenges in Cambodia, Lao PDR, Myanmar, and Vietnam*. In *Investment Climate of Major Cities in CLMV Countries* (Ed.: M. Ishida), BRC Research Report No.4, Bangkok Research Center, IDE-JETRO, Bangkok, Thailand.
4. Belgian Technical Corporation (2006). *Master plan for waterborne transport on the Mekong River system in Cambodia, final report*.
5. Bell, M. G. H., Liu, X., Angeloudis, P., Fonzone, A., Hosseinloo, S. H. (2011). A frequency-based maritime container assignment model. *Transportation Research*, 45B: 1152–1161.
6. Christiansen, M., Fagerholt, K., Nygreen, B., Ronen, D. (2013). Ship routing and scheduling: in the new millennium. *European Journal of Operational Research*, 228: 467–483.
7. Fan, L., Wilson, W. W., Tolliver, D. (2009). Logistical rivalries and port competition for container flows to US markets: Impacts of changes in Canada's logistics system and expansion of the Panama Canal. *Maritime Economics & Logistics*, 11: 327–357.
8. Fan, L., Wilson, W. W., Dahl, B. (2012). Congestion, port expansion and spatial competition for US container imports. *Transportation Research*, 48E: 1121–1136.
9. Goh, M., Ang, A. (2000). Some logistics realities in Indochina. *International Journal of Physical Distribution & Logistics Management*, 30: 887–911.
10. Gupta, A., Hock, L., Xiaojing, H., Ping, C. (2002). Evaluation of part of the Mekong River using satellite imagery. *Geomorphology*, 44: 221–239.
11. Hanaoka, S. (2013). Port competition in Cambodia. *Journal of Maritime Researches*, Kobe University, 3: 31–38.
12. Hanaoka, S., Nakamichi, K., Kato, T. (2014). Measurement of modal split considering environmental impact of interregional freight transport in Greater Mekong Subregion. Infrastructure Planning and Management, *Journal of Japan Society of Civil Engineers*, 70: I_879–I_888. [in Japanese]
13. International Transport Forum (ITF)-OECD (2015). *ITF Transport Outlook 2015*.
http://www.keepeek.com/Digital-Asset-Management/oecd/transport/itf-transport-outlook-2015_9789282107782-en#page1 last accessed on December 1, 2016.
14. Isono, I. (2010). *Economic impacts of the economic corridor development in Mekong region*. In *Investment Climate of Major Cities in CLMV Countries* (Ed.: M. Ishida), BRC Research Report No.4, Bangkok Research Center, IDE-JETRO, Bangkok, Thailand.
15. Japan International Cooperation Agency (JICA) (2012). *Final report for the project for the study on strengthening competitiveness and development of Sihanoukville Port in the Kingdom of Cambodia*.
<http://libopac.jica.go.jp/images/report/P1000005179.html> last accessed on December 1, 2016.
16. Japan International Cooperation Agency (JICA) (2013). *The preparatory survey on Phnom Penh Autonomous Port new container terminal's special economic zone and associated facilities construction project in Kingdom of Cambodia: final report*.
<http://libopac.jica.go.jp/images/report/P1000013602.html>, last accessed on December 1, 2016.
17. Kawasaki, T., Hanaoka, S., Nguyen, L. X. (2015). Inland cargo flow modelling considering shipment time variability on cross-border transport. *Transportation Planning and Technology*, 38: 664–683. DOI: 10.1080/03081060.2015.1048947
18. Konings, J. W., Horst, M. R. van der, Hutson, N., Kruse, J. (2010). Comparative strategies for developing container barge hinterland transport: a SWOT-analysis for Rotterdam and US ports. *Proceedings of the Transportation Research Board 89th Annual Meeting*, 10–14 January 2010, Washington D. C.
19. Kumagai, S., Hayakawa, K., Isono, I., Keola, S., Tsubota, K. (2013). Geographical simulation analysis for logistics enhancement in Asia. *Economic Modelling*, 34: 145–153.
20. Lee, C. Y., Song, D. P. (2016). Ocean container transport in global supply chains: Overview and research opportunities. *Transportation Research*, 95B: 442–474. <http://dx.doi.org/10.1016/j.trb.2016.05.001>.
21. Liu, Z., Meng, Q., Wang, S., Sun, Z. (2014). Global intermodal liner shipping network design. *Transportation Research*, 61E: 28–39.
22. Manatunge, J., Akatsuka, Y., Asaeda, T., Fujino, T. (1997). Inland navigation in the Mekong: issues and prospects for sustainability. *Pre-prints of the Symposium on Global Environment*, Japan Society of Civil Engineers, 5: 197–202. <http://doi.org/10.11532/proge1993.5.197>
23. Meng, Q., Wang, X. (2011). Intermodal hub-and-spoke network design: Incorporating multiple stakeholders and multi-type containers. *Transportation Research*, 45B: 724–742.
24. Meng, Q., Wang, S., Andersson, H., Thun, K. (2014). Containership routing and scheduling in liner shipping:

- overview and future research directions. *Transportation Science*, 48: 265–280.
25. Ozawa, S., Kume, H., Ishihara, N., Nakaharai, S. (2010). Current states and future prospects of inland waterway in the Chang Jiang: focus on comparison with European situations. *Journal of Logistics and Shipping Economics (Japan Society of Logistics and Shipping Economics)*, 44: 69–78. [in Japanese]
 26. Rudjanakanoknad, J., Limsathayurat, N. (2015). Level of transportation infrastructure and public utility readiness for Thai investors in Myanmar, Cambodia, and Lao PDR economic zones. *Journal of the Eastern Asia Society for Transportation Studies*, 11: 1–15.
 27. Sheffi, Y. (1985). *Urban Transportation Networks: Equilibrium Analysis with Mathematical Programming Methods*. New Jersey: Prentice-Hall, Inc.
 28. Shibasaki, R., Ma, L., Kannami, Y., Ieda, H., Yoshida, T., Miao, L. (2007). Model expansion of international container cargo simulation for cross-border transport policy in Southeast Asia. *Proceedings of the Second International Conference on Transportation and Logistics (T-LOG 2007)*, July 2007, Shenzhen, China.
 29. Shibasaki, R., Watanabe, T., Araki, D. (2010). How is model accuracy improved by usage of statistics? An example of international freight simulation model in East Asia. *Asian Transport Studies*, 1: 33–46.
 30. Shibasaki, R., Watanabe, T. (2012). Future forecast of trade amount and international cargo flow in the APEC Region: An application of trade-logistics forecasting model. *Asian Transport Studies*, 2: 75–89.
 31. Shibasaki, R., Suzuki, M., Shimada, T. (2014). Intermodal freight simulation in Southern Mekong region: route choice model for international container shipping. *Proceedings of the Fifth International Conference on Transportation and Logistics (T-LOG 2014)*, 28–30 July 2014, Bangkok, Thailand.
 32. Shibasaki, R., Iijima, T., Kawakami, T., Kadono, T., and Shishido, T. (2017). Network assignment model of integrating maritime and hinterland container shipping: application to Central America. *Maritime Economics & Logistics*, 19(2): 234–273. DOI: 10.1057/s41278-016-0055-3
 33. Sisovanna, S. (2012). *A study on cross-border trade facilitation and regional development along economic corridors in Cambodia. In Emerging economic corridors in the Mekong Region* (Ed.: M. Ishida), BRC Research Report No.8, Bangkok Research Center, IDE-JETRO, Bangkok, Thailand.
 34. Srivastava, P. and Kumar, U. (Eds.) (2012). *Trade and trade facilitation in the Greater Mekong Subregion*, ADB Publishing, Mandaluyong City, Philippines. <http://www.adb.org/sites/default/files/pub/2012/trade-and-trade-facilitation-gms.pdf>, last accessed on December 1, 2016.
 35. Suzuki, S., Shimada, T. (2014). Port selection and land/IWT choices in Cambodia. *Proceedings of the Fifth International Conference on Transportation and Logistics (T-LOG 2014)*, 28–30 July 2014, Bangkok, Thailand.
 36. Tavasszy, L., Minderhoud, M., Perrin, J. F., Notteboom, T. (2011). A strategic network choice model for global container flows: specification, estimation and application. *Journal of Transport Geography*, 19: 1163–1172.
 37. Tran, N. K., Haasis, H. D., Buer, T. (2016). Container shipping route design incorporating the costs of shipping, inland/feeder transport, inventory and CO2 emission. *Maritime Economics & Logistics* (online). DOI: 10.1057/mel.2016.11.
 38. Tuan, V. A. (2011). Making passenger inland waterways a sustainable transport mode in Asia: current situation and challenges. *Proceedings of the Eastern Asia Society for Transportation Studies*, 8.
 39. Utomo, D. M., Mateo-Babiano, I. (2015). Exploring indigeneity of inland waterway transport (IWT) in Asia: case studies of Thailand, Vietnam, the Philippines, and Indonesia. *Journal of the Eastern Asia Society for Transportation Studies*, 11: 2316–2332.
 40. Veenstra, A., Zhang, M., Ludema, M. (2008). The growth potential of container shipping on the Yangtze River. *Maritime Policy Management*, 35: 535–549.
 41. Veenstra, A., Notteboom, T. (2011). The development of the Yangtze River container port system. *Journal of Transport Geography*, 19: 772–781.
 42. Yang, Z., Shi, H., Chen, K., Bao, H. (2014). Optimization of container liner network on the Yangtze River, *Maritime Policy Management*, 41: 79–96.
 43. Zheng, J., Yang, D. (2016). Hub-and-spoke network design for container shipping along the Yangtze River, *Journal of Transport Geography*, 55: 51–57.
 44. Wang, X., Meng, Q., Miao, L. (2016). *Delimiting port hinterlands based on intermodal network flows: Model and algorithm*, *Transportation Research*, 88E: 32–51.
 45. Wang, X., Meng, Q. (2017). *Discrete intermodal freight transportation network design with route choice behavior of intermodal operators*, *Transportation Research*, 95B: 76–104.