



ISSN 1392–3730 print / ISSN 1822–3605 online

JOURNAL OF CIVIL ENGINEERING AND MANAGEMENT<http://www.jcem.vgtu.lt>

2007, Vol XIII, No 1, 27–36

APPLICATION OF COMPUTER SIMULATION TO CONSTRUCTION OF INCREMENTAL LAUNCHING BRIDGES

Mohamed Marzouk¹, Hisham Zein El-Dein², Moheeb El-Said³

*Dept of Structural Engineering, Faculty of Engineering, Cairo University, Giza, Egypt.
E-mail: ¹mm_marzouk@yahoo.com; ²h_zeineldin@yahoo.com; ³elsaid1204@yahoo.com*

Received 21 Nov 2005; accepted 24 May 2006

Abstract. Construction of bridges is associated with uncertainties that rise due to unavailability of resources, equipment breakdown and/or working environment. Bridge construction techniques can be grouped into six main categories: 1) cast-in-situ on false work, 2) cantilever carriage, 3) stepping formwork, 4) launching girder, 5) pre-cast balanced cantilever, and 6) incremental launching. The latter technique is characterised by minimising the use of falsework. Further, the fabrication and casting of bridge segments are executed at a stationary location, named casting yard (which includes several facilities), deck form, concrete mixing unit, and pumping system. This paper presents a special purpose simulation model to capture the uncertainty associated with bridge construction. The model accounts for the interaction between the different involved resources in construction of bridges using incremental launching technique. The paper describes two methods (single form and multiple forms) of execution used for the segments fabrication. The proposed simulation model utilises STROBOSCOPE as a simulation engine and is coded by Visual Basic 6.0. An actual case study is presented to illustrate the capabilities of the developed model and validate its performance.

Keywords: planning, bridge construction, computer simulation, incremental launching bridges, scheduling, uncertainties.

1. Introduction

Computer simulation is a powerful tool for the analysis of new and existing systems. A project simulation uses a model that translates the uncertainties specified at a detailed level of the project into their potential impact on project objectives [1]. Analysis of projects using simulation is performed for several purposes [2]. These include: evaluation of a proposed system; comparison between alternative proposals; prediction of system performance under different conditions; sensitivity analysis to determine the most significant factors affecting the performance of a system; optimization to determine the best overall response of a system; functional relations to recognize any relationship among the system significant factors; and bottlenecks analysis to identify the factors that cause system delays.

Computer simulation is one of the techniques that has been used to model uncertainties involved in construction operations [3]. Although simulation is a powerful tool for modelling construction operations, the application of simulation is still limited in the construction domain. This has generally been attributed to the difficulty in learning and applying simulation languages to industry [4–6].

Typically, modelling utilising simulation can be applied either in a general or special purpose simulation environment. General purpose simulation (GPS) is based on formulating a simulation model for the system under investigation, running the simulation and analysing the results to decide whether the system is acceptable or not. In case of being unacceptable, the process is reiterated and a new alternative system is considered. Various GPS





software systems have been developed for a wide range of industries: AweSim [7] and GPSS/H [8]; for construction: Micro-CYCLONE [9] and STROBOSCOPE [10]. Special purpose simulation (SPS) is based on creation of a platform or a template for a specific domain of application [11, 3]. The steps for simulation, in this case, are the same as in the GPS case, except for the first step (construct simulation model), since the platform already includes the characteristics and behaviour of the system under study. Also, the modification is limited to the input parameter(s) of a pre-defined system and not to the characteristics and behaviour of the system.

This paper presents a special purpose simulation model, dedicated to assist contractors in planning the segmental bridge construction using incremental launching technique. It utilises STROBOSCOPE as a simulation engine to model the activities inherited in construction of bridges' decks using incremental launching technique. STROBOSCOPE simulation elements (Table 1) are used to model tasks involved in single form and multiple forms methods. These elements include Normal, Combi, Queue, Arc, and Fusion Queue [10]. The model is coded utilising Visual Basic 6.0. The following sections describe the developments made in the proposed incremental launching simulation model.

2. Incremental launching construction technique

Concrete bridges can be grouped, according to their type, into ordinarily reinforced and pre-stressed bridges. Ordinarily reinforced bridges cannot be used in long span

Table 1. STROBOSCOPE simulation elements [10]

Symbol	Name	Description
	NORMAL	Unconstrained in its starting logic and indicates active processing of (or by) resource entities
	COMBI	Logically constrained in starting, otherwise similar to the NORMAL work task modelling element
	QUEUE	Represents a queuing up or waiting for use of passive state resources
	ARC	Used to model the direction of resource entity flow between various active state nodes and passive state nodes
	Fusion QUEUE	Represents the queue which bears its name

bridges. Pre-stressed bridges are utilized to overcome the above mentioned limitation of ordinary reinforced concrete bridges. With respect to the construction methodology, concrete bridges can be classified into six techniques: 1) cast-in-situ on false-work, 2) cantilever carriage, 3) flying shuttering, 4) launching girder, 5) pre-cast balanced cantilever, and 6) incremental launching. Several factors are considered when selecting the construction technique. These are: i) ingenuity of the designers and contractors, ii) resources availability, and iii) technical limitations. Incremental launching construction technique is characterised by using less temporary falsework and other expedients that are required during the construction as in the case of cast-in-situ on false-work technique [12]. It entails incremental fabrication of the superstructure at a stationary location, longitudinal movement of fabricated segment and casting of a new segment onto the one previously cast [13]. In other words, the procedure can be considered as a horizontal slip-form technique, except that the fabrication and casting occur at a stationary loca-

tion (behind bridge’s abutment). In incremental launching construction technique, there are two systems of launching. The first one has the jacks bearing on an abutment face and pulling on a steel rod, which is attached by launching shoes to the last segment cast. The second method is essentially a lift-and-push operation using a combination of horizontal and vertical jacks. Construction of a bridge deck using incremental launching technique involves three major operations: i) casting yard preparation, ii) segments fabrication, and iii) set-up of bridge deck. Fig 1 depicts the simulation network that represents bridge deck construction by incremental launching technique.

The casting yard is used to accommodate temporary facilities utilised for segment fabrication. These facilities include deck form, concrete mixing unit, and pumping system. The deck form consists of several components as shown in Fig 2. The second major operation in the incremental launching technique is segments fabrication, which involves fabrication cycles of equal segments that have a length equal to half or full length of the typical span. The

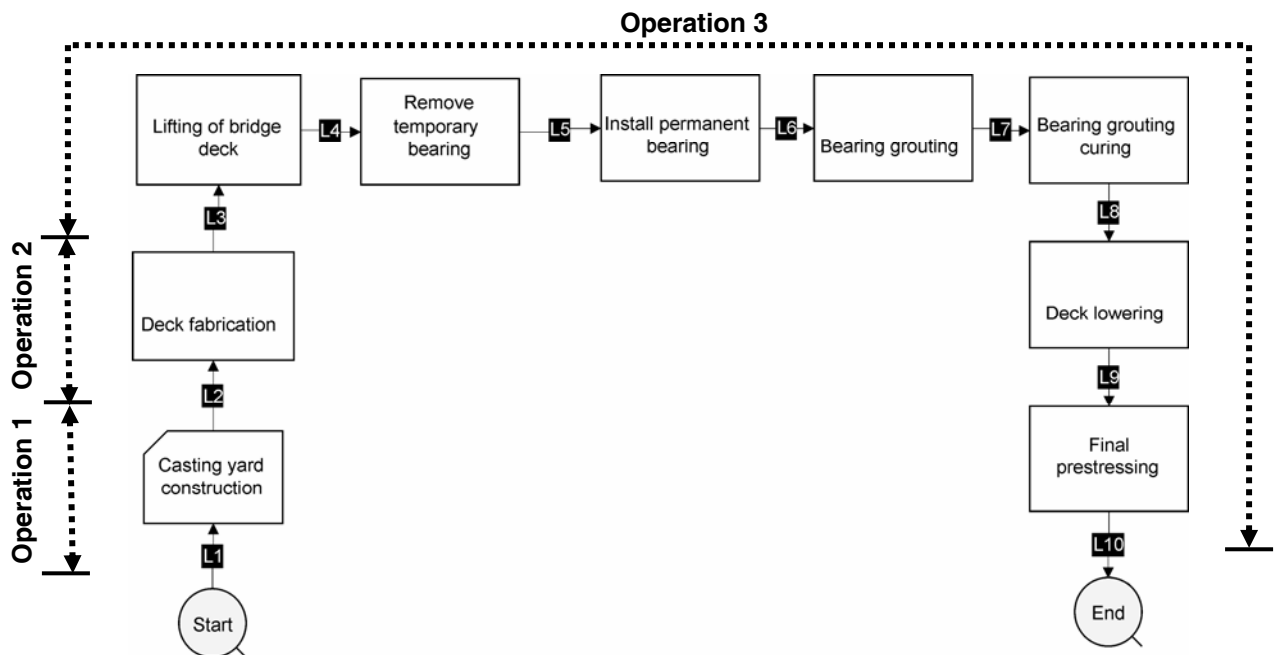

Fig 1. Simulation network for deck pushing technique

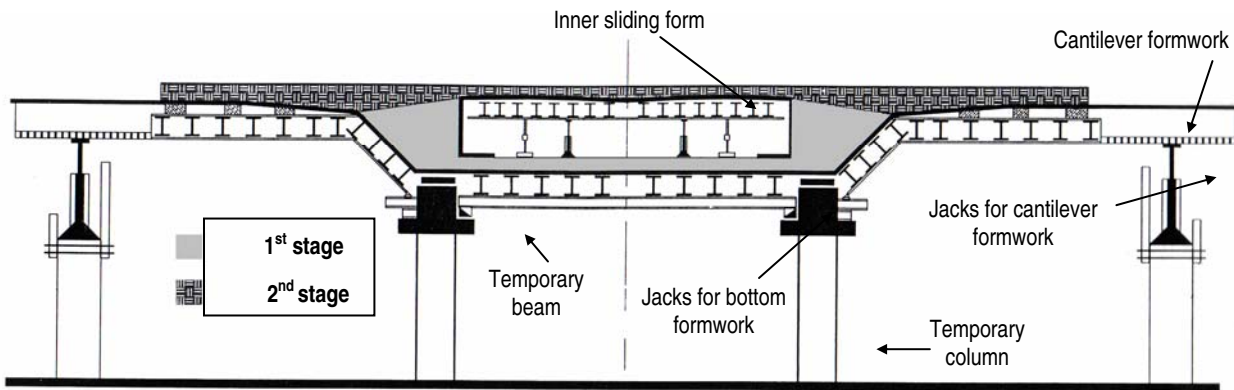

Fig 2. Components of deck form

fabrication cycle consists of three main processes which are broken down in successive tasks. The three processes are: 1) bottom flange and webs fabrication, 2) top flange fabrication, and 3) pre-stressing process. Segment fabrication can be performed either by a single form or multiple forms method. The set-up of bridge deck operation starts after the whole bridge deck is fabricated and pushed. It involves final pre-stressing of the bridge deck tendons, removal of temporary bearings, and permanent bearings installation. The following sections describe the modelling of the two methods (single form and multiple forms), used for segments fabrication in incremental launching technique.

3. Modelling incremental launching using single form

In this method of fabrication, three processes are executed in order to produce a single segment (Table 2). These are: i) bottom flange and webs fabrication, ii) top

flange fabrication, and iii) incremental launching. Each process consists of a number of tasks, creating a total of 19 tasks. The first and second processes are accomplished successively in the same station. Before segment fabrication, the forms must be cleaned, raised and aligned. Reinforcement steel bars and pre-stressing ducts are placed for bottom flange and webs before they are poured. After sufficient curing period, inner sliding forms are used to cast the top flange (Fig 2). Then, the whole fabricated segment is pre-stressed and pushed.

Fig 3 depicts the simulation network, developed to represent segments fabrication operation using the single form method. Six resources are defined for this simulation network: four for labour crews, one for pump, and one named Segment to represent fabricated segment and to maintain tasks' logic. The logic and inference of the simulation is achieved by two tools: Arc elements and flow control statements. Arc elements are used to model the direction of resource entity flow between tasks. Flow

Table 2. Processes and tasks of single form method

Process	Task code	Task description
Bottom flange and webs fabrication	P1	Cleaning, raising, aligning, and grading of forms
	P2	Placement of 1/2 reinforcement for the bottom flange and webs (1 st stage rebar)
	P3	Placement of ducts for the bottom flange and webs (1 st stage tendons)
	P4	Finish reinforcement for the bottom flange and webs (1 st stage rebar)
	P5	Erection of inner side forms
	P6	Concreting of the first phase (1 st stage casting)
	P7	Curing of the first phase (1 st stage curing)
Top flange fabrication	P8	Removing of inner side forms
	P9	Pulling of inner top forms
	P10	Placement of 1/2 reinforcement for the top flange (2 nd stage rebar)
	P11	Placement of ducts for the top flange (2 nd stage tendons)
	P12	Finish reinforcement for the top flange (2 nd stage rebar)
	P13	Concreting of the second phase (2 nd stage casting)
	P14	Curing of the second phase (2 nd stage curing).
Incremental launching	P15	Tendons installation into pre-stressing ducts
	P16	Pre-stressing of tendons, first stage of longitudinal tendons and transversal tendons.
	P17	Dismantling and lowering of formwork
	P18	Surface check and finishing
	P19	Incremental launching

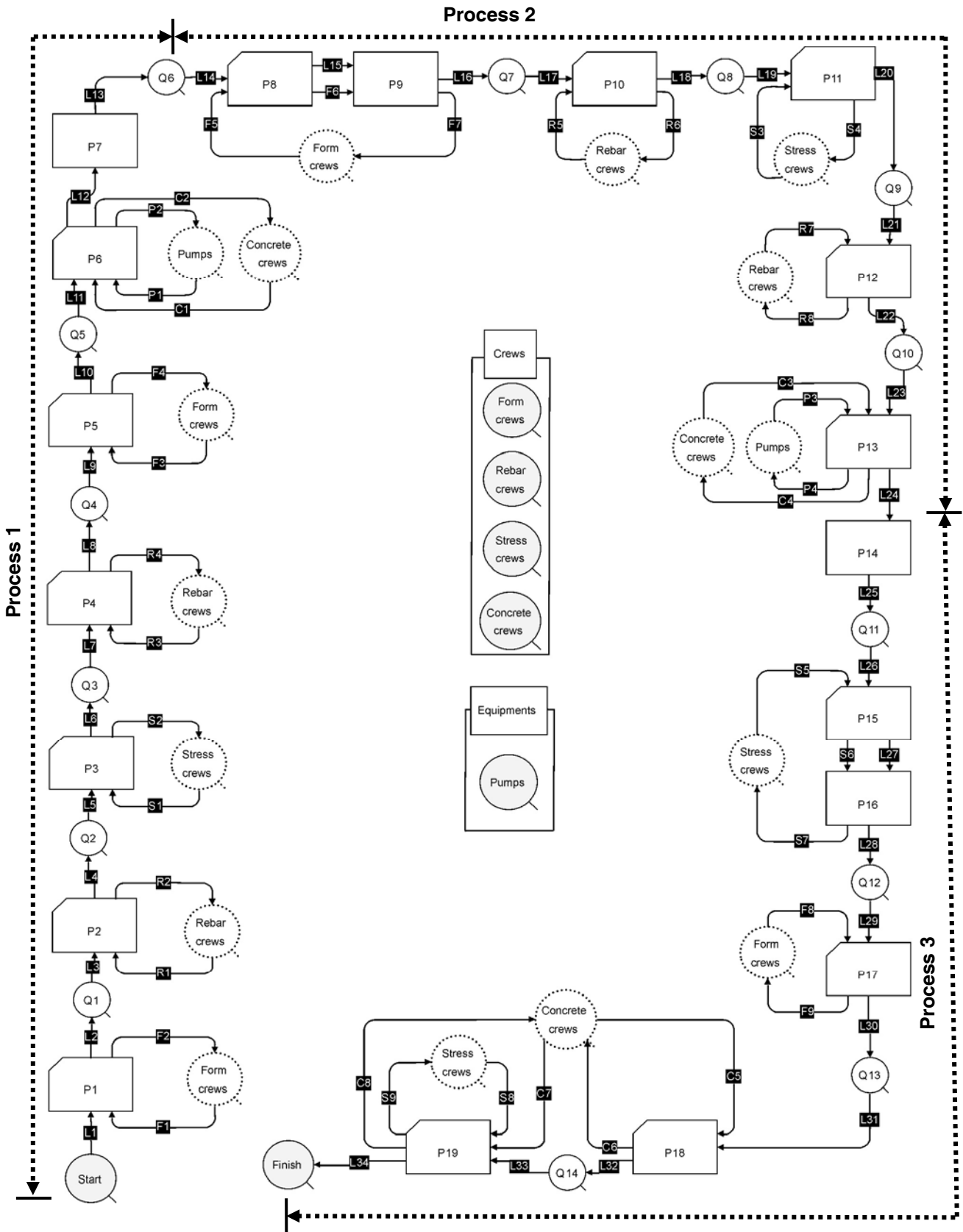

Fig 3. Simulation network for single form method

control statements are used to control tasks' initiations, resources draw, resources release, and any conditional logical aspect that controls the operation. It is worth to note that the simulation network is developed as open-loop despite the fact that the operation is repetitive. The network starts with a *Queue* named *Start* and ends with a *Queue* named *Finish*. The *Start Queue* is initiated with a quantity equal to the total number of segments using *Segment* resource as follows:

```
INIT Start Nsegments;
```

Segment resources are drawn from *Start Queue* one by one. Each *Segment* resource goes through the nineteen tasks and then vanishes at *Finish Queue*. The cycle of a segment means has been cast, stressed, and pushed. Among the uses of flow control statements is to satisfy conditional statements as referred to earlier. For example, a flow control statement is used to prevent multiple segments from being executed simultaneously. The following *SEMAPHORE* statement assures that *P1 Combi* cannot start before finishing the current segment (i.e., executing *P19 Combi*).

```
SEMAPHORE TASK1
'P1.TotInst==P19.TotInst;
```

4. Modelling incremental launching by multiple forms

To speed up the construction by the incremental launching technique, two fabrication stages can be executed simultaneously using separate forms (Fig 4). The bottom flange and webs' bottom stubs of the first segment are erected and poured. After curing, prestressing of the first partial segment (ie bottom flange and bottom stubs of the webs) is performed. Subsequently, it is jacked and forwarded to the second form to fabricate the remaining part of the segment. As such, the form can be reused for the fabrication of the bottom flange for the second segment. This is a typical cycle in which two fabrication processes occur simultaneously: i) top flange of the second segment and ii) the bottom flange and webs' bottom stubs of the first segment. Once the reinforcement is set in two successive segments (typical cycle), the two segments are cast, cured, stressed, and jacked together. For incremental launching construction using multiple forms, bottom flange and webs and top flange fabrication are modelled in a single process, since they are fabricated simultaneously. Therefore, this method consists of two major processes which are deck fabrication and prestressing. These two processes have 17 tasks which are listed in Table 3. The simulation network for segments fabrication operation using multiple forms method is depicted in Fig 5.

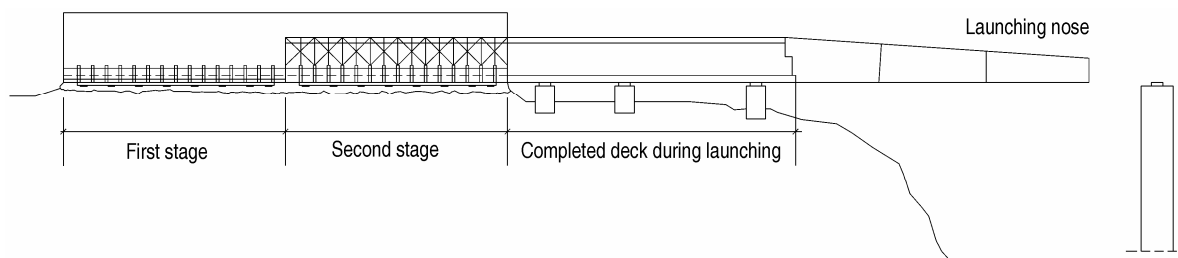

Fig 4. Segments fabrication by multiple forms method

Table 3. Processes and tasks of multiple forms method

Process	Task code	Task description
Deck fabrication	FClean	Cleaning, raising, aligning, and grading of the first form
	FRebar1	Placement of 1/2 reinforcement for the bottom flange and bottom stubs of webs (1 st stage rebar)
	FDucts	Placement of ducts for the bottom flange and bottom stubs of webs (1 st stage tendons)
	FRebar2	Finish reinforcement for the bottom flange and bottom stubs of webs (1 st stage rebar)
	SideForms	Erection of inner side forms
	Remove	Removing inner side forms
	InnerForms	Pulling inner top forms
	SRebar1	Placement of 1/2 reinforcement for the top flange and webs (2 nd stage rebar)
	SDucts	Placement of tendons for the top flange and webs (2 nd stage tendons)
	SRebar2	Finish reinforcement for the top flange and webs (2 nd stage rebar)
	Casting	Concrete casting for both 1 st and 2 nd stages
	Curing	Curing for both 1 st and 2 nd stages
Incremental launching	InstallTendons	Tendons installation into prestressing ducts
	Stressing	Prestressing of tendons, first stage of longitudinal tendons and transversal tendons
	Dismantle	Dismantling and lowering of formwork
	SurfaceCheck	Surface check and finishing
	DeckPushing	Pushing for the whole bridge deck

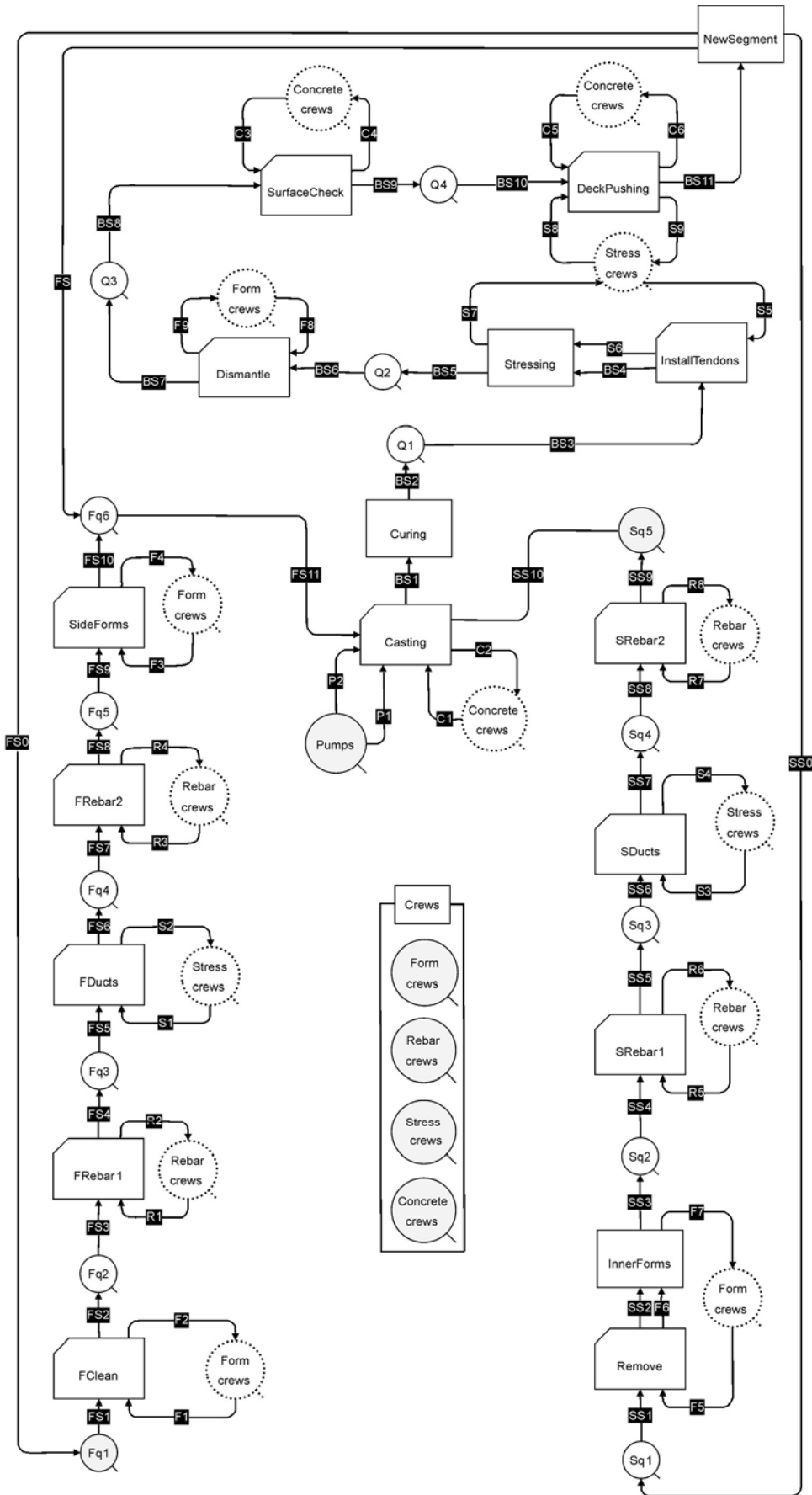

Fig 5. Simulation network for multiple forms method

Flow control statements and dummy elements are used in modelling incremental launching construction technique using multiple forms method requires both. At the beginning of deck construction, the first stage involves execution of the bottom flange and bottom stubs of webs for the first segment only. This is accomplished via using two *Queues*, named Fq_1 and Sq_1 . In the first cycle, Fq_1 is assigned a single *Segment* resource while assigning null resource in Sq_1 . As such, only the tasks of the first stage are executed. To perform casting task, a single *Segment* resource is assigned in Sq_5 *Queue* that exists in the second stage fabrication path. For subsequent cycles, both the first and second tasks are performed simultaneously, except for the final cycle which involves the execution of the second stage fabrication for the last segment. Therefore, the first stage tasks in the simulation network are frozen as the following control statements:

```
IF FClean.TotInst<Nsegments;
  RELEASEAMT FS0 1;
  RELEASEAMT FS 0;
ELSEIF
  FClean.TotInst>=Nsegments;
RELEASEAMT FS0 0;
RELEASEAMT FS 1;

ENDIF;
```

The above control statements release the resources that emerge from the dummy *Normal* element, named *NewSegment*, which receives only one *Segment* resource at a time. Releasing *Segment* resource to *Arcs* (FS0, FS, and SS) depends on the current construction status. If there are remaining segments that need to be passed through the first stage fabrication (ie, $FClean.TotInst < Nsegments$), the *Arc* FS is frozen while *Arc* FS0 is engaged with a *Segment* resource. As such, the tasks of the first and second stages are performed simultaneously in a typical cycle (ie two successive segments). The tasks are continuously executed until all segments are finished with the first stage fabrication (ie $FClean.TotInst \geq Nsegments$). In this case, FS0 *Arc* is frozen, while FS *Arc* is engaged with the last *Segment* resource. This leads to vanishing *Segment* resources from Fq_1 *Queue*, which represents the first *Queue* in the first stage path, preventing the first stage tasks from being launched.

5. Case study

To validate the proposed simulation model, data from an actual project were utilised. The case considers the construction of the 15th May bridge, located in Cairo, Egypt. The bridge was constructed using incremental

launching technique with a single form as shown in Fig 6. It consists of 35 equal spans; each has a length of 25 m. The total length of the bridge is 875 m which is considered too long to be constructed and pushed using a single fabrication area. Therefore, the scope of work was divided into two zones, *Zone I* with a 550 m length and *Zone II* with a 325 m length. Each zone is fabricated and pushed using its respective fabrication area, producing typical segments that have a length of 12,5 m. As such, 44 and 26 segments were fabricated for *Zone I* and *Zone II*, respectively. Duration of processes tasks are listed in Table 4. It should be noted that the work in the project was limited to 8 working hours per day.

Bridge data were fed to the simulation model, conducting 100 simulation replications to calculate the duration of deck construction in each zone. Simulation experiment was conducted in two stages. First, segments fabrication was modelled for each zone (Operation 2 in Fig 1). *Zone I* consumed longer duration with a mean value equals 397,1 days. As such, the production rate of segments obtained from the simulation model is 9,03 days/segment, compared to 10 days/segment as actual production in 15th May bridge. Second, the output obtained from the first stage was used to model the whole construction of bridge deck (simulation network depicted in Fig 1) using data listed in Table 5. The average duration of bridge deck construction is estimated to be 425,3 days with a standard deviation of 5,4 days.

The case is also considered to be constructed using multiple forms method as per the data listed in Table 6. The duration of casting yard preparation and set-up of bridge deck are modelled using the values, by the single form method (Table 5). A sensitivity analysis was performed to evaluate the system performance under different combinations of resources. The involved resources are four labour crews (formwork, reinforcement, stressing, and concrete crews) and concrete pump equipment. Concrete labour crew and pump are not considered in the analysis since their change does not affect production rate. Therefore, a concrete crew and single pump are allocated for all considered combinations. Table 7 lists eight combinations of crews and their estimated mean and standard deviation values for segment fabrication and deck construction durations.

Using the multiple forms method (with minimum number of crews) decreases the duration of segment fabrication to be 374,43 days with associated production rate of 8,51 days/segment. It should be noted that increasing the number of labour crews shortens the fabrication duration as per Table 6. The results indicate that the deck construction is very sensitive to the rebar crew. A compression in segment fabrication duration of 37,39 days is obtained by doubling the rebar crew. The shortest durations are obtained by doubling the number of all crews (formwork, reinforcement, stressing, and concrete crews). In this combination, the estimated durations for segment fabrication and deck construction are 330,14 and 359,09 days, respectively. It has a production rate of 7,5 days/segment.

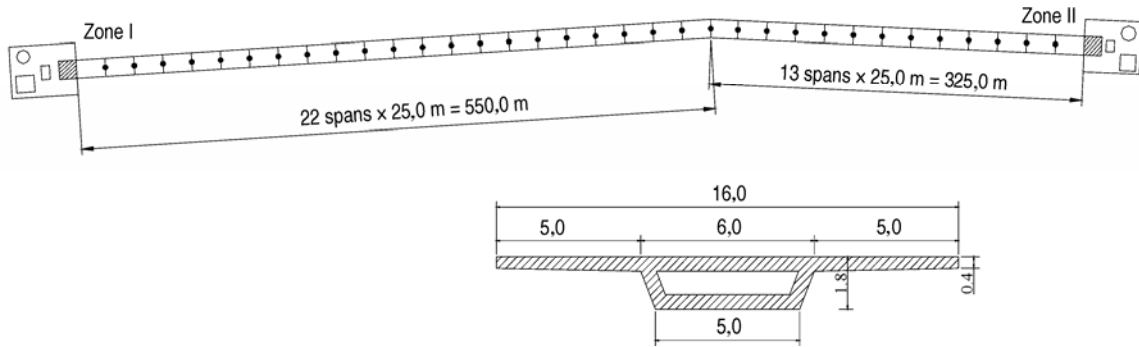

Fig 6. 15th May bridge: layout and cross-section

Table 4. Durations of single form method tasks

Process	Task	Duration (min)
Bottom flange and webs fabrication	Cleaning, raising, aligning, and grading of forms	N(120,60)
	Placement of 1/2 reinforcement for the bottom flange and webs (1 st stage rebar)	Pg(300,360,420)
	Placement of tendons for the bottom flange and webs (1 st stage tendons)	N[130,60]
	Finish reinforcement for the bottom flange and webs (1 st stage rebar)	Pg[270,360,420]
	Erection of inner side forms	U[60,240]
	Concreting the first phase (1 st stage casting)	T[270,360,420]
	Curing the first phase (1 st stage curing)	U[360,600]
Top flange fabrication	Removing of inner side forms	U[45,120]
	Pulling inner side forms	U[30,90]
	Placement of 1/2 reinforcement for the top flange (2 nd stage rebar)	Pg[300,400,600]
	Placement of tendons for the top flange (2 nd stage tendons)	N[120,50]
	Finish reinforcement for the top flange (2 nd stage rebar)	Pg[300,400,600]
	Concreting the second phase (2 nd stage casting)	T[360,420,480]
	Curing the second phase (1 st stage curing)	U[360,600]
Incremental launching	Tendons installation into pre-stressing ducts	U[30,120]
	Pre-stressing tendons, first stage of longitudinal tendons and transversal tendons	U[60,180]
	Dismantling and lowering formwork	U[90,240]
	Surface check and finishing	U[15,60]
	Incremental launching	N[120,45]

Note:

$U[a,b]$: Uniform distribution; a is the lower value; b is the higher value.

$T[a,b,c]$: Triangle distribution; a is the lower value; b is the mode value; c is the higher value.

$N[a,b]$: Normal distribution; a is the mean value; b is the standard deviation.

$Pg[a,b,c]$: Perry & Grieg Beta distribution; a is the value at 5%; b is the mode value; c is the value at 95 %.

Table 5. Duration of incremental launching tasks

Operation	Task	Duration
Preparation	Casting yard preparation	U(13,25) days
Deck fabrication	Output from first simulation stage	N(397.1,3.2) days
Set-up of bridge deck	Lifting of bridge deck	U(16,32) hrs
	Removing temporary bearings	U(6,12) hrs
	Installing permanent bearings	U(4,12) hrs
	Bearings grouting injection	U(4,8) hrs
	Bearings grouting curing	U(6,10) hrs
	Lowering of bridge deck	U(8,16) hrs
	Final pre-stressing	U(8,16) hrs

Note: U and N are uniform and normal distributions, respectively.

Table 6. Durations of multiple forms method tasks

Process	Task	Duration (min)
Deck fabrication	Cleaning, raising, aligning, and grading of first form	N(120,60)
	Placement of 1/2 reinforcement for the bottom flange and bottom stubs of webs (1 st stage rebar)	Pg(300,360,420)
	Placement of tendons for the bottom flange and bottom stubs of webs (1 st stage tendons)	N[130,60]
	Finish reinforcement for the bottom flange and bottom stubs of webs (1 st stage rebar)	Pg[270,360,420]
	Erection of inner side forms	U[60,240]
	Removing inner side forms	U[45,120]
	Pulling inner top forms	U[30,90]
	Placement of 1/2 reinforcement for the top flange and webs (2 nd stage rebar)	Pg[300,400,600]
	Placement of tendons for the top flange and webs (2 nd stage tendons)	N[120,50]
	Finish reinforcement for the top flange and webs (2 nd stage rebar)	Pg[300,400,600]
	Concrete casting for both 1 st and 2 nd stages	T[360,420,480]
	Curing for both 1 st and 2 nd stages	U[960,1920]
Incremental launching	Tendons installation into pre-stressing ducts	U[30,120]
	Prestressing tendons, first stage of longitudinal tendons and transversal tendons	U[60,180]
	Dismantling and lowering formwork	U[90,240]
	Surface check and finishing	U[15,60]
	Pushing for whole bridge deck	N[120,45]

Note: U, T, N and Pg are uniform, triangle, normal, and pertpg distributions, respectively.

Table 7. Results of sensitivity analysis

ID	Form crews	Rebar crews	Stressing crews	Segment fabrication Duration (days)		Total deck construction Duration (days)	
				Mean	σ	Mean	σ
1	1	1	1	375	4,5	405	6,1
2	2	1	1	379	4,3	408	5,8
3	1	2	1	338	4,6	366	5,8
4	2	2	1	333	4,1	362	5,2
5	1	1	2	376	3,7	405	5,2
6	1	2	2	337	4,1	365	5,1
7	2	1	2	378	4,4	407	5,6
8	2	2	2	331	4,1	360	6,3

6. Conclusions

This paper presented a model for construction of bridges using incremental launching technique. The model applies computer simulation to take into consideration uncertainty and interaction amongst involved resources. It supports two construction methods: single form and multiple forms. In the former method, only one segment is executed at construction time, whereas the latter method allows execution of two successive segments simultaneously. The typical cycle of segment fabrication, by two methods, consists of three processes: 1) bottom flange and webs fabrication, 2) top flange fabrication, and 3) prestressing. The paper described the design considerations made to maintain the logic and inference of simulation process by Arc elements and flow control statements. Arc elements are used to model the direction of resource entity flow between a task and its predecessors and successors tasks, whereas flow control statements are used to control tasks' initiations, resources draw amounts, resources release amounts, and any conditional logical

aspect related to the construction work. An actual case study example was presented to examine the results of the developed model and illustrate its capabilities in modelling single form and multiple forms methods. A sensitivity analysis was conducted for the case to study the impact of assigned resources in the estimated durations of segment fabrication and deck construction. The results of the study reveal that the deck construction is very sensitive to rebar crew.

References

1. PMBOK[®]. *A guide to the project management body of knowledge*. 3rd ed, Project Management Institute, Inc., Pennsylvania, USA, 2004. 388 p.
2. SHANNON, R. E. Introduction to simulation. In *Proc of the 1992 Winter Simulation Conference*, Arlington, VA, USA, 1992, p. 65–73.
3. ABOURIZK, S. M. and HAJJAR, D. A framework for applying simulation in construction. *Canadian Journal of Civil Engineering*, 5(3), 1998, p. 604–617.

4. SAWHNEY, A. and ABOURIZK, S. M. Computerized tool for hierarchical simulation modeling. *Journal of Computing in Civil Engineering*, 10(2), 1996, p. 115–124.
5. OLOUFA, A.; IKEDA, M. and NGUYEN, T. Resource-based simulation libraries for construction. *Automation in Construction*, 7(4), 1998, p. 315–326.
6. TOURAN, A. Integration of simulation with expert systems. *Journal of Construction Engineering and Management*, 116(3), 1990, p. 480–493.
7. PRITSKER, A. A. B.; O'REILLYAND, J. J. and LAVAL, D. K. *Simulation with Visual SLAM and AweSim*. John Wiley & Sons, Inc., New York, NY, 1997. 811 p.
8. CRAIN, R. C. Simulation using GPSS/H. In *Proc of the 1997 Winter Simulation Conference*, Atlanta, GA, USA, 1997, p. 567–573.
9. HALPIN, D. W. and RIGGS, L. S. *Planning and analysis of construction operations*. John Wiley & Sons, Inc., New York, NY, 1992. 400 p.
10. MARTINEZ, J. C. *STROBOSCOPE – State and resource based simulation of construction processes*. PhD thesis, University of Michigan, 1996. 518 p. (available at <http://strobos.ce.vt.edu>)
11. MARZOUK, M. and MOSELHI, O. An object – oriented model for earthmoving operations. *Journal of Construction Engineering and Management*, 129(2), 2003, p. 173–181.
12. PODOLNY, W. and MULLER, J. M. *Construction and design of prestressed concrete segmental bridges*. John Wiley & Sons, Inc., New York, NY, 1982. 561 p.
13. NISEE. Incrementally launched bridges. University of California, Berkeley, 1997. (available at http://nisee.berkeley.edu/leonhardt/html/incrementally_launched_bridges.html).

LAIPSNIŠKAI UŽSTUMIAMŲ TILTŲ STATYBOS PROCESO KOMPIUTERINIS MODELIAVIMAS

M. Marzouk, H. Zein El-Dein, M. El-Said

Santrauka

Tiltų statybos procesas susijęs su daugeliu neapibrėžtumų, kurie atsiranda dėl išteklių stygiaus, įrangos gedimų ir (arba) darbo aplinkos. Tiltų statybos technologijos gali būti suskirstytos į šešias pagrindines kategorijas: 1) betonavimas statybos vietoje ant įrengtų klojinių, 2) montavimas kabamuoju metodu, 3) betonavimas statybos vietoje, taikant perstatomuosius klojinius, 4) montavimas, užstumiant sijas, 5) montavimas kabamuoju pusiausviroju metodu ir 6) montavimas, taikant laipsnišką išilginį užstūmimą. Pastarojoje technologijoje iki minimumo sumažinamas klojinių poreikis. Be to, tilto perdangos segmentų gamyba ir montavimas atliekamas statybos aikštelėje, kurioje įrengiami klojiniai, betono gamybos ir tiekimo į parengtus klojinius mazgai. Šiame straipsnyje pateikiamas specialios paskirties modelis neapibrėžtumams tiltų statybos procese įvertinti. Modelyje įvertinta laipsniško užstūmimo metodu statomiems tiltams reikalingų skirtingų išteklių tarpusavio sąveika. Straipsnyje aprašomi du statybos metodai (viena forma ir daug formų), kurie taikomi segmentams gaminti. Pasiūlytame modelyje panaudota STROBOSCOPE skaičiavimo programa, sukurta *Visual Basic 6.0* programavimo kalba. Pasiūlytojo modelio veiksmingumui pagrįsti pateiktas praktinio taikymo pavyzdys.

Reikšminiai žodžiai: projektavimas, tilto statyba, kompiuterinis modeliavimas, laipsniško užstūmimo metodas, planavimas, neapibrėžtumai.

Mohamed MARZOUK. Assistant Professor at Dept of Structural Engineering, Faculty of Engineering, Cairo University. BSc and MSc in Civil Engineering from Cairo University in 1995 and 1997, respectively. PhD from Concordia University in 2002. Member of Egyptian Code of Practice for Construction Management, and Quality Control Committee, National Organisation for Civilisation Reformation, Ministry of culture. His research interests include simulation and optimisation of construction processes, O-O simulation, fuzzy logic and its applications in construction, risk analysis, and decision analysis.

Hisham ZEIN EL-DEIN. Assistant Lecturer at Dept of structural engineering, Faculty of engineering, Cairo University. BSc and MSc in Structural Engineering from Cairo University in 2003 and 2006, respectively. His research interests include simulation of construction operations, optimisation applications, construction technologies, and construction productivity.

Moheeb EL-SAID. Professor of construction engineering and management at Dept of structural engineering, Faculty of engineering, Cairo University. A member of Egyptian code of practice for construction management, and chairman of Quality control committee, National organisation for civilisation reformation, Ministry of culture. His research interests include productivity, scheduling, risk assessment, life cycle costs, and simulation.