

## An Improved Under-Frequency Load Shedding Scheme in Distribution Networks with Distributed Generation

A. Mokari, H. Seyedi, B. Mohammadi-Ivatloo\*, S. Ghasemzadeh

Faculty of Electrical and Computer Engineering, University of Tabriz, Tabriz, Iran

### ABSTRACT

When a distribution network consisting of Distributed Generations (DGs) is disconnected from upstream network, the system may be exposed to severe power imbalance. In order to prevent the damage of power plants, frequency relays operate and remove DGs from the network. In contrast to traditional methods, the main objective in new methods is to keep DG units in service in the islanded distribution system. Under-Frequency Load Shedding (UFLS) is one of the most important protection systems, which is the last chance for avoiding a system blackout following severe disturbance. This paper dealt with an adaptive UFLS method and considered the priority of loads to be shed, depending on the intensity of event, and loads look up table built by Rate of Change of Frequency of Loads (ROCOFL) indices based on the frequency of centre of inertia ( $f_{COI}$ ). Different loads were shed depending on the event type diagnosed by measuring the initial Rate of Change of Frequency (ROCOF) in the method. The proposed UFLS method can stabilize the frequency of the distribution system in islanding mode by shedding sufficient loads. The simulation results confirmed the advantages of the methods in comparison to other proposed algorithms.

**KEYWORDS:** Distributed generation, Load shedding, Frequency control, Islanded operation.

### 1. INTRODUCTION

Power systems may be exposed to unacceptable frequency drops, due to sudden load increase, disconnection of critical generators, and/or system islanding. Islanding, as a result of out-of-step relay operation, may lead to one or more islands with generation deficiency [1].

One of the key strategies to avoid cascading failures in an islanded network is to apply Under-Frequency Load Shedding (UFLS) methods [2-3]. These methods automatically drop a certain amount of loads from the system to restore the balance between generation and consumption.

Spinning reserves are the unused capacity connected to the network. After removing some of the loads, spinning reserves adjust the imbalance by producing power [4].

Loads uncertainty and different consumption patterns cause complexity in the function of UFLS relays. Several algorithms have been proposed for load shedding, which are generally classified as follows [5]:

1. Traditional load shedding
2. Semi-adaptive load shedding
3. Adaptive load shedding

Obviously, adaptive methods have better results than traditional ones. Three types of adaptive UFLS methods were discussed in [6]. An adaptive load shedding method uses rate of change of frequency (ROCOF) as a measure of imbalance severity [5-7]. The reduced System Frequency Response (SFR) model provides a relation between the initial ROCOF and the amount of imbalance ( $P_{def}$ ). Voltage dependence of loads is not considered in SFR model, which causes an error in  $P_{def}$  calculation [8].

Under-frequency load shedding in the presence of spinning reserves was completely described in [9]. According to [10], it is not necessary to shed an amount of load which is exactly equal to  $P_{def}$ .

Received: 26 Sep. 2013

Revised: 27 Feb. 2014

Accepted: 14 Mar. 2014

\*Corresponding author:

B. Mohammadi-ivatloo (E-mail: [bmohammadi@tabrizu.ac.ir](mailto:bmohammadi@tabrizu.ac.ir))

© 2014 University of Mohaghegh Ardabili

Some previous works have explored new methods for calculating the imbalance between production and consumption, in which voltage dependence of loads has been considered [11-13].  $f_{cor}$  was calculated and compared with ROCOF of each bus to build priority table of loads in [14].

All the recent methods have used initial Rate of change of frequency (ROCOF) for estimating power imbalance. ROCO of loads (ROCOFL) indices were assigned in [15]. Due to the importance of DGs and renewable resources, these units are used in most distribution networks. High penetration of DG units allows the network to operate in an islanded mode as a microgrid. The islanded operation of the distribution networks has been investigated in [14] and [15]. The point is that the strategy for load shedding in distribution networks with DGs must be different from other systems [15]. Centralized under-frequency load shedding scheme based on a frequency stability boundary curve defined within the  $\omega$ - $d\omega/dt$  (frequency versus ROCOF) phase plan was presented in [16]. Several UFLS methods, based on frequency gradient and ROCOF thresholds, intentional time delays and step sizes in conventional methods have been proposed in the literature. To optimize the amount of load shedding in UFLS methods, optimal UFLS methods have been also suggested, which are categorized into deterministic and heuristic optimization algorithms. In deterministic optimization algorithms, frequency thresholds, intentional delay times and step sizes are optimized. In [17], an optimization by means of Quasi-Newton methods was presented. In heuristic algorithms, all frequency thresholds and intentional delay times are fixed and step sizes are optimized. In [18], an optimization was presented using Genetic Algorithm (GA). Variation of UFLS step sizes and impact of non-responding turbine generator systems in UFLS methods were analyzed by Monte Carlo approach in [19].

In this paper, an adaptive ROCOF-based algorithm is presented using load priority table based on loads ROCOFL indices. In this adaptive method, the intensity of event is divided into 3 types of severe, moderate and weak. In the proposed adaptive method, frequency threshold values, intentional delay times and step sizes are changed,

depending on the measured ROCOF values. This method shed different loads depending on the event type which is diagnosed by measuring initial ROCOF. The rest of this paper is organized as follows; in Sec. 2, the proposed method is discussed. In this section, load shedding flowchart is also illustrated and described. In Sec. 3, assumptions and test system are explained. In Sec. 4, the methodology is implemented in a 14-bus Danish distribution system in three different load imbalance case studies. In Sec. 5, conclusions are made.

## 2. THE PROPOSED METHOD

In the proposed method, in order to avoid network instability, frequency relays continuously sent the values of frequencies and frequency variations to the control center to perform the required actions and select the loads to be shed. By removing these loads, the network would return to its nominal frequency and an islanded network could operate in a normal state.

In [15], ROCOFL indices were determined for each of the loads. To determine ROCOFL indices, the following procedure is applied in this paper. First, it is assumed that the network continued to work in an islanded mode and there is no imbalance in the network. Note that this assumption is just for calculating the ROCOFL indices. To determine ROCOFL index, the amount of each load is separately duplicated in the balanced system and initial ROCOF is measured. Loads are not assumed to be voltage- and frequency-dependent in determining ROCOFL indices.

In ROCOFL index determination presented in [15], the following problems were encountered:

- Loads were continuously changing and were not accurately predictable.
- Voltage and frequency dependence of loads caused an error in calculating ROCOFL index.
- $f_{cor}$  was not used in this method.

Using reduced SFR model, ROCOF had a linear relation with the active power imbalance. So, the first problem could be solved by updating index values every few minutes using Eq. (1). Active powers of loads were transmitted to the control center every few minutes and they did not require a high-speed communication link [8].

$$ROCOFL^* = ROCOFL \times \left( \frac{P_{newi}}{P_{oldi}} \right) \quad (1)$$

In this equation,  $P_{newi}$  is the  $i^{th}$  load's active power transmitted to the control center and  $P_{oldi}$  shows the  $i^{th}$  load's active power and preliminary calculations were based on it. This method can be partly used to solve the load uncertainty.

Active power of loads is multiplied by a factor of 1.05 to model their voltage dependence in SFR model [8]. In this paper, the calculated initial ROCOF should be multiplied by a factor of 1.05 to solve the second problem.

Active and reactive powers of loads were voltage- and frequency-dependent and modeled by Eqs. (2) and (3) in this paper [20]:

$$P_{newi} = P_{oldi} \left( \frac{V}{V_0} \right)^{K_{pv}} \left( 1 + K_{pf} \times \frac{\Delta f}{f_0} \right) \quad (2)$$

$$Q_{newi} = Q_{oldi} \left( \frac{V}{V_0} \right)^{K_{qv}} \left( 1 + K_{qf} \times \frac{\Delta f}{f_0} \right) \quad (3)$$

$V_0$  and  $f_0$  are nominal voltage and frequency, respectively,  $K_{pv}$  and  $K_{qv}$  determine the dependence of active and reactive powers on the voltage, and  $K_{pf}$  and  $K_{qf}$  represent the dependence of active and reactive powers on frequency, respectively.

If  $P_{newi}$  obtained by (2) is replaced with (1) and real time voltage signal value is accessible, it will be possible to update ROCOFL index values using (4):

$$ROCOFL^* = ROCOFL \times \left( \frac{P_{newi}}{P_{oldi}} \right) \times \left( \frac{V}{V_0} \right)^{K_{pv}} \quad (4)$$

According to [14], the derivative of  $f_{COI}$  was used in the present calculations presented in (5) to solve the third problem.

$$f^*_{COI,pu} = \frac{\left( \sum_{i=1}^n f^*_{el_0,i,pu} \times H_{i,gen} \right)}{H_{COI}} \quad (5)$$

In this equation,  $f^*_{COI,pu}$  shows the initial ROCOF of the network and  $f^*_{el_0,i,pu}$  represents the initial ROCOF of the  $i^{th}$  generator.  $H_{COI}$  and  $H_{i,gen}$  show the network center of inertia constant and the  $i^{th}$  generator inertia constant, respectively.

UFLS method presented in [15] had the following drawbacks which were solved by the proposed method:

- Spinning reserves could make the system tolerate small disturbances. In order to prevent over-shedding, the initial critical frequency variation ( $m_{0critical}$ ) should be compared with the amount of measured initial ROCOF, which was not considered in [15].

$m_{0critical}$  shows the maximum variation of frequency that can be tolerated by the network without shedding any loads. The modified initial ROCOF can be determined as follows.

$$\frac{df^*}{dt}(t=0)_{COI} = 1.05 * \frac{df}{dt}(t=0)_{COI} - m_{0critical} \quad (6)$$

- Loads priority table is based on the willingness of loads to pay (WTP) in [15]. In this method, system constraints were not considered. Some of the loads had to be shed first to restore system to the normal state as soon as possible. An optimal UFLS method should be used to consider WTP of loads and specification constraints of the system.

In the proposed algorithm, prioritizing the loads for shedding is considered based on two different procedures in order to improve the voltage stability margins.

Using Eq. (7), D matrix for the operating system can be obtained.

$$D = \begin{bmatrix} d_{11} & \dots & \dots & \dots & \dots \\ \dots & \dots & \dots & \dots & \dots \\ \dots & \dots & d_{ij} & \dots & \dots \\ \dots & \dots & \dots & \dots & \dots \\ \dots & \dots & \dots & \dots & d_{nm} \end{bmatrix} \begin{matrix} G_1 \\ G_2 \\ \dots \\ \dots \\ G_n \end{matrix} \quad (7)$$

$L_1 \quad L_2 \quad \dots \quad L_m$

$L_m$  and  $G_n$  are  $m^{th}$  load and  $n^{th}$  generator in the system, respectively, and parameter  $d_{nm}$  is the least distance between  $L_m$  and  $G_n$ .

In the first procedure, using Eq. (8), the loads that were far from the remaining generators in the network were removed.

$$Max \sum_{i=1}^n \sum_{j=1}^m d_{ij} \quad (8)$$

$i \neq k$

In the second procedure, using Eq. (9), the loads that are far from the large remaining generators in the network are removed.

$$\text{Max} \sum_{\substack{i=1 \\ i \neq k}}^n \sum_{j=1}^m d_{ij} P_i \quad (9)$$

where,  $P_i$  determines the  $i^{\text{th}}$  load's active power.

In the proposed method, computations for determining updated ROCOFL indices are performed offline. Information obtained in the control center is processed and the loads for shedding are prioritized. After data processing, instructions for frequency load shedding are sent by the control center to the local relays.

- ROCOF threshold value presented in [15] corresponded to the lowest ROCOFL index. Different event types, which cause over-shedding at small disturbances are not considered in this method. Loads were shed according to the measured initial ROCOF and ROCOF threshold value in this method. Unshed loads had to wait for the frequency to go down below the frequency threshold and for the ROCOF to be negative for the duration of  $T$ . ROCOF values had to be sent by frequency relays to the control center every half cycle after islanding detection.

In the proposed method, two different ROCOF thresholds which are obtained by studying different scenarios are applied. These threshold values diagnosed different types of events in the system. In this centralized adaptive method, the intensity of event is divided into 3 types of severe, moderate, and weak, which is not considered in [15]. In the proposed adaptive method, frequency threshold values, intentional delay times, and step sizes are changed based on the measured initial ROCOF value. In the proposed method, only initial ROCOF value is used after islanding detection.

### 2.1. Proposed UFLS flowchart

Flowchart of the proposed adaptive UFLS method is presented in Fig.1. Initially, the islanded operation of distribution network is detected by islanding detection methods as given in [21].

To operate the proposed methodology, loads are arranged to shed according to the mentioned prioritizing. Since the load's active powers are sent to the control center every few minutes, the amounts of ROCOFL indices are updated. Using the updated

amounts and calculated modified initial ROCOF determined the loads to be shed. When the system frequency reached specified frequency thresholds, the loads are shed in each step. According to the event severity, frequency thresholds and amount of load shedding in each step are changed. If in the presence of all the above constraints, the number of determined loads ( $N$ ) is zero and, in order to prevent frequency instability, the load with minimum ROCOFL index is selected to be shed. Moreover, if  $\frac{df}{dt}(t=0)_{COI}$  is less than  $m_{critical}$  and  $f_{COI}$  is less than  $f_{LI}$  for more than  $T_1$  sec, the load with the lowest ROCOFL index would be removed.

Intensity and frequency thresholds of the proposed adaptive ROCOF-based UFLS scheme are presented in Table 1. If  $\frac{df}{dt}(t=0)_{COI}$  was less than  $M$  and greater than  $m_{critical}$ , the event was recognized as a moderate event. In moderate events, the proposed shed loads of adaptive UFLS scheme are in the three different steps presented in Table 1. If  $f_{COI}$  is less than  $f_{th1}$  for at least  $y_1$  sec,  $x_1$  percent of the determined loads was shed. If frequency is less than  $f_{th2}$  for  $y_2$  sec,  $x_2$  percent of determined loads are shed in the second step. In the third step, frequency is less than  $f_{th3}$  and the rest of the determined loads were shed. If  $\frac{df}{dt}(t=0)_{COI}$  is greater than  $M$ , the event is recognized as a severe one. In this event, all of the determined loads are shed when  $f_{COI}$  is less than  $f_{L2}$  for more than  $T_2$  sec.

$M$  and  $m_{critical}$  were obtained through studying various scenarios. Moreover,  $M$  was determined for the case that 30% of production was lost [22]. Intentional time delays and frequency thresholds for each step were achieved by analyzing various scenarios. Using the proposed algorithm, appropriate UFLS scheme can operate to return the system to its normal function.

### 3. ASSUMPTIONS AND TEST SYSTEM

The proposed algorithm is tested on the Danish 14-bus network [15]. All the simulation studies were performed using DigSilent Power Factory 14.0.520. Figure 2 shows the single line diagram of Danish distribution network. The model also employed Combined Heat and Power (CHP) plant with three

gas turbine generators (3 MW each) which were installed at bus 1. The model used for CHP unit is presented in [23]. Network data and generator parameters were taken from [24]. The distribution network is connected to the transmission network at bus 02. The test system also consisted of three fixed-speed stall regulated wind generators (WTGs) (630 KW each) which were installed at buses 8, 9, and 10.

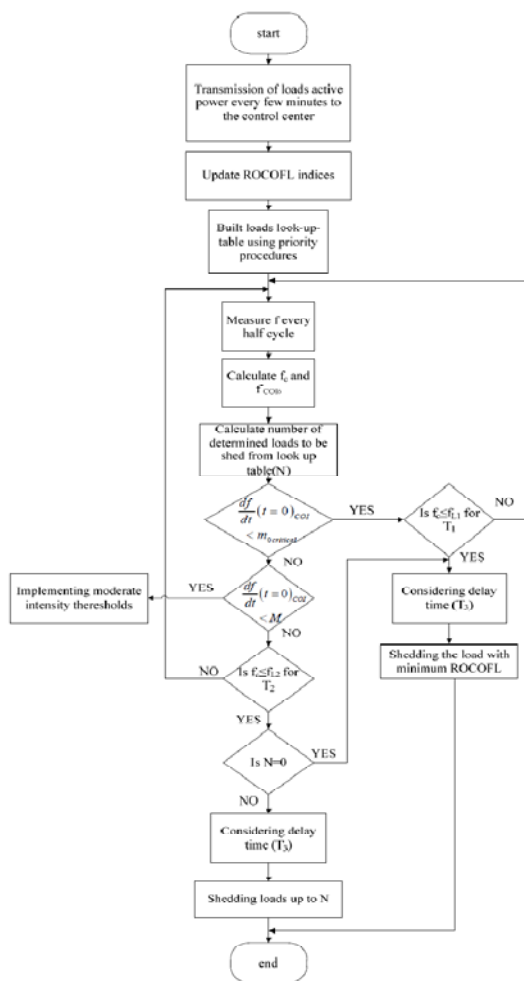

Fig. 1. Flowchart of the proposed method

The distribution system continued to operate as an islanded network in the event of upstream outage. An IEEE-type ST1 excitation system and GAST model were used to model the exciter and governor in the proposed CHP plant, respectively. The parameters of the exciters and governors were given in [24]. Power demand over two months from December 2006 to January 2007 was given in [15].

Table 1. Frequency settings and time delays in adaptive UFLS scheme

Event type	Initial ROCOF	Frequency state	Amount of load shedding
weak	$\frac{df}{dt}(t=0)_{COI} < m_{0critical}$	$f_c < f_{L1}$ for $T_1$	The load with lowest amount
moderate	$m_{0critical} < \frac{df}{dt}(t=0)_{COI} < M$	Step1: $f_c < f_{th1}$ for $y_1$	Step1: x1% of determined loads
		Step2: $f_c < f_{th2}$ for $y_2$	Step2: x2% of determined loads
		Step3: $f_c < f_{th3}$	Step3: rest of determined loads
severe	$\frac{df}{dt}(t=0)_{COI} > M$	$f_c < f_{L2}$ for $T_2$	all of the determined loads

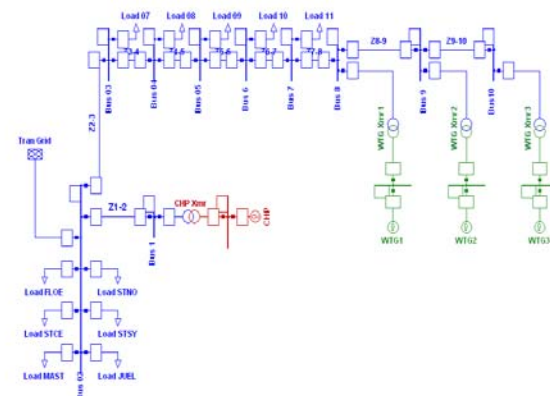

Fig. 2. Single line diagram of 14-bus Danish distribution system

Static load models are used in the simulation studies. The loads are assumed to be voltage and frequency-dependent and modeled using (2) and (3). The following parameters are used for load modeling [20].

$$k_{pv} = 1, k_{qv} = 2, k_{pf} = 1, k_{qf} = -1$$

Frequency thresholds of  $f_{th1}, f_{th2}, f_{th3}, f_{L1}$ , and  $f_{L2}$  are 49.2, 48.5, 48, 49, and 49.5 Hz, respectively. According to [15], the imposed delay time ( $T_3$ ) caused by breaker operation and transmission delay is considered to be 80 ms. Intentional delay times of

$T_1$ ,  $T_2$ ,  $y_1$ , and  $y_2$  are 120, 60, 100, and 200, respectively.

According to the pervious works, the specified loads are shed in three different modes. Type of mode determined values of  $x1$  and  $x2$ . Three modes are applied in this paper.

- 1) 40% - 50% - 10%
- 2) 60% - 10% - 30%
- 3) 33.33% - 33.33% - 33.33%

Different specified percentages of the determined loads are dropped in each step based on the type of mode.

Inertia values and power ratings of the generators are as follows:  $H_{wind} = 0.38$  s;  $S_{wind} = 692$  KVA;  $H_{CHP} = 0.54$  s; and  $S_{CHP} = 4.125$  MVA.

The amount of  $m_{critical}$  depended on the type of network and was obtained by studying different scenarios. The amount of  $m_{critical}$  in 14-bus distribution test system is 0.5 Hz/s.

#### 4. RESULTS AND DISCUSSION

The proposed algorithm requires the calculation of ROCOFL index for each of the loads. Calculation of the applied indices is performed offline. For modeling the effect of load variation, the calculated ROCOFL indices are updated using (1). Since wind generators are not always presented in the network, index calculations is considered for the worst state (without taking wind generators into account). ROCOFL index values obtained for the loads in December 2006 and the updated values in January 2007 are listed in Table 2.

In this section, three different load cases are considered:

- Base load: 14-bus Danish system with loads in January 2007.
- First load imbalance: Loads STSY, STCE, STNO, 11, 10, 9, and 8 are increased by 10 percent in January 2007.
- Second load imbalance: All of the loads are increased by 10 percent in January 2007.

Using the calculated indices, the required look up table is formed. The look up tables formed by priority procedures of loads are presented in Tables 3 and 4 for the base load.

**Table 2.** ROCOFL values of December 2006 and updated values of January 2007

Load	ROCOFL(HZ/s)	ROCOFL*(HZ/s)
	December 2006	January 2007
8	-3.5	-3.25
JUEL	-4	-4
9	-0.55	-0.5
10	-0.55	-0.5
11	-0.55	-0.5
7	-2.2	-2.05
STCE	-5.15	-5.25
FLQE	-8.5	-9.55
STSY	-8.55	-7.45
STNO	-7.7	-9
MAST	-11.5	-12.5

**Table 3.** Look up table for the first priority procedure in the base load

N	Load	Max $\sum_{i,j} dij$	ROCOFL <sub>i</sub>	$\sum$ ROCOFL <sub>i</sub>
1	JUEL	13.69	-4	-4
2	STCE	13.69	-5.25	-9.25
3	STSY	13.69	-7.45	-16.7
4	STNO	13.69	-9	-25.7
5	FLQE	13.69	-9.55	-35.25
6	MAST	13.69	-12.5	-47.75
7	7	12.75	-2.05	-49.8
8	8	11.36	-3.25	-53.05
9	9	10.29	-0.5	-53.55
10	10	10	-0.5	-54.05
11	11	6.33	-0.5	-54.55

The distribution system is disconnected from the upstream network at  $t=2$  s. Figure 3 shows the system frequency during islanding without load shedding in different load cases.

Frequency cannot reach the acceptable range of frequency after 10 sec. If UFLS method is not applied, the generator's under-frequency relays would trip and the system would collapse.

#### 4.1 Base load

In the base load, the net imbalance is 2.91 MW. CHP frequency at  $t=2.01$  s dropped to 49.491 Hz and the CHP frequency variation is measured as 5.9 Hz/s. In an islanded operation, CHP increased its output using its governor.

Using the results of the performed simulation, an initial ROCOF of each generator is obtained. According to (5), the initial ROCOF of network is equal to 6.65 Hz/s.

As mentioned in Sec. 2, to model the effect of load's voltage dependence, the measured initial ROCOF was multiplied by a factor of 1.05. Using (6), the modified initial ROCOF is equal to 6.48 Hz/s. Here, initial ROCOF is less than  $M$ ; so, it is diagnosed as a moderate incident. After 140 ms, the frequency dropped to 49.2 Hz. Frequency relays waited for 0.1 s ( $\gamma I$ ) to prevent the false operation of relays in transient state.

**Table 4.** Look up table for the second priority procedure in the base load

N	Load	$\text{Max} \sum \sum d_{ij} P_i$	$\text{ROCOFL}_i$	$\sum \text{ROCOFL}_i$
1	11	35.66	-0.5	-0.5
2	10	18.27	-0.5	-1
3	9	16.81	-0.5	-1.5
4	8	12.46	-3.25	-4.75
5	7	4.31	-2.05	-6.8
6	JUEL	3	-4	-10.8
7	STCE	3	-5.25	-16.05
8	STSY	3	-7.45	-23.5
9	STNO	3	-9	-32.5
10	FLQE	3	-9.55	-42.05
11	MAST	3	-12.5	-54.55

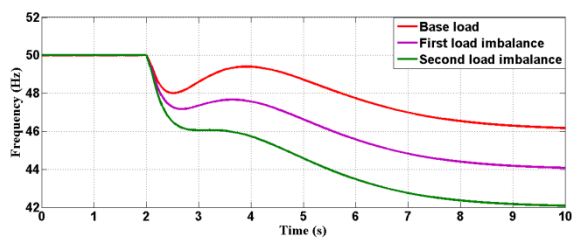

**Fig. 3.** System frequency without load shedding in different load cases

In the first mode of UFLS method, load's JUEL is shed at  $t=320$  ms. After shedding the specified load, there is a 200 ms time interval.

Since the system frequency is less than 48.5 Hz ( $f_{th1}$ ), the next load is removed at  $t=600$  ms.

Results of UFLS scheme for both priority procedures in three modes of adaptive load shedding are presented in Table 6. According to the results, the second mode of the proposed adaptive algorithm sheds fewer amounts of loads than the other adaptive modes with an acceptable system frequency for both priority procedures.

#### 4.2 First load imbalance

In the first load imbalance, loads STSY, STCE, STNO, 11, 10, 9, and 8 are increased by 10 percent.

In this case, the net imbalance is 3.5 MW. Using the results of the performed simulation, the modified initial ROCOF is 8.53 Hz/s. Using (1), the updated values of ROCOFL indices are as mentioned in Table 7.

**Table 6.** Under-frequency load shedding scheme for the base load in 14-bus Danish system

Loads priority procedure	Determined loads	Adaptive UFLS mode	Dropped loads	Amount of determined loads (MW)	Amount of load shedding (MW)	Minimum frequency
1	JUEL, STCE	1	JUEL - STCE	2.072	2.072	48.23
		2	STCE		1.172	48.24
		3	JUEL - STCE		2.072	48.23
2	11,10,9,8,7	1	7, 9- 8	1.5291	1.2991	48.194
		2	8, 9- 10, 11		1.0693	48.223
		3	7, 9- 8		1.2991	48.194

**Table 7.** Updated values of ROCOFL indices for the first and second load imbalances

Load	ROCOFL* (HZ/s)	ROCOFL* (HZ/s)
	First load imbalance	Second load imbalance
8	-3.57	-3.57
JUEL	-4	-4.4
9	-0.55	-0.55
10	-0.55	-0.55
11	-0.55	-0.55
7	-2.05	-2.255
STCE	-5.775	-5.775
FLQE	-9.55	-10.505
STSY	-8.195	-8.195
STNO	-9.9	-9.9
MAST	-12.5	-13.75

Results of UFLS scheme for both priority procedures in three modes of the proposed adaptive load shedding in the first load imbalance are presented in Table 8.

#### 4.3 Second load imbalance

In the second load imbalance, all of the loads are increased by 10 percent in 14-bus Danish system.

In this case, the net imbalance is increased to 4.12 MW. Using the results of the performed simulation, the modified initial ROCOF is obtained as 10.57 Hz/s. Updated values of ROCOFL indices are presented in Table 7. This case is diagnosed as a severe incident. Results of UFLS scheme for the second load imbalance are presented in Table 9.

**Table 8.** Under-frequency load shedding scheme for the first load imbalance in 14-bus Danish system

Loads priority procedure	Determined loads	Adaptive UFLS mode	Dropped loads	Amount of determined loads (MW)	Amount of load shedding (MW)	Minimum frequency
1	JUEL, STCE	1	JUEL-STCE	2.189	2.189	47.73
		2	STCE-JUEL		2.189	47.82
		3	JUEL-STCE		2.189	47.73
2	11, 10, 9, 8, 7, JUEL	1	8, 9- JUEL, 10- 7, 11	2.536	2.536	47.73
		2	7, 8- 9, 10		1.509	47.81
		3	7, 9, 10- 8- JUEL, 11		2.189	47.73

**Table 9.** Under-frequency load shedding scheme for the second load imbalance in 14-bus Danish system

Loads priority procedure	Determined loads	Dropped loads	Amount of determined loads (MW)	Amount of load shedding (MW)	Minimum frequency
1	JUEL, STCE, STSY	JUEL, STCE, STSY	4.1	4.1	48.08
2	11, 10, 9, 8, 7, JUEL	11, 10, 9, 8, 7, JUEL	2.672	2.672	47.99

The amount of load shedding in the improved algorithm compared with the algorithm presented in [15] is shown in Table 10. It is obvious that the proposed algorithm can shed fewer loads than the method proposed in [15]. Figures. 4-6 present CHP frequency of the proposed adaptive UFLS scheme compared with UFLS algorithm presented in [15] after shedding specified loads.

According to the results, in a small distribution network, all of the determined loads do not need to be shed for small disturbance. However, the determined loads must be shed with minimum delay time in severe events.

**Table 10.** The amount of dropped loads in both proposed and conventional ([15]) UFLS algorithms for different load imbalances

Load case	Imbalance (MW)	Loads priority procedure	Amount of load shedding using proposed method (MW)	Amount of load shedding using [15] (MW)
Base load	2.91	1	1.172	3.728
		2	1.0693	2.4291
First load imbalance	3.5	1	1.509	4.0108
		2	2.189	2.536
Second load imbalance	4.12	1	4.1	4.1
		2	2.672	2.672

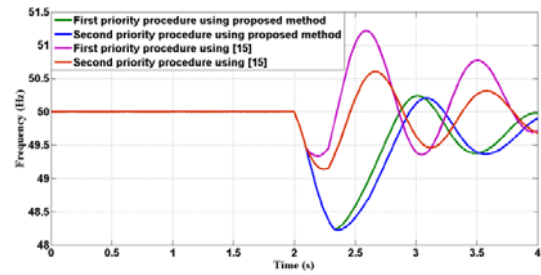

**Fig. 4.** CHP frequency after load shedding in the base load

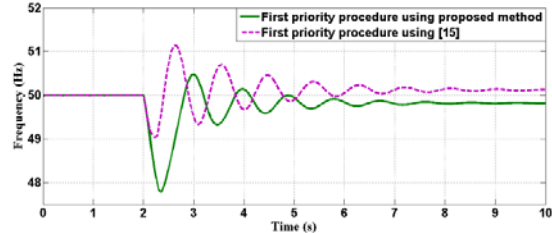

**Fig. 5.** CHP frequency after load shedding in the first load imbalance

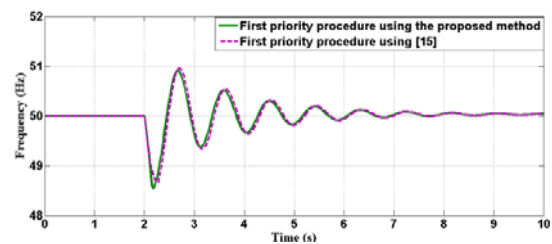

**Fig. 6.** CHP frequency after load shedding in the second load imbalance

## 5. CONCLUSION

When an islanded distribution network with distributed generators is supposed to continue its operation, under-frequency load shedding should be specifically designed for the network. In this paper, ROCOFL indices is used to provide load's look up table for two priority procedures. The effects of voltage variation on the implemented indices are considered using an appropriate correction factor. In the improved UFLS method, frequency threshold values, intentional delay times and step sizes are changed based on the measured initial ROCOF value. The measured initial ROCOF value diagnosed the event intensity, which itself determined frequency thresholds and delay times. This method updated values of ROCOFL indices every few minutes; the procedure in which fast communication link is not required. Load's voltage dependence is considered in the selection of the determined loads. This algorithm is implemented on the 14-bus Danish distribution



system and the results are compared with an existing algorithm. The results confirmed that the proposed improved UFLS algorithm shed fewer loads than the existing one.

## REFERENCES

- [1] S. Najafi, M. Abedi and S.H. Hosseinian, "A strategy for frequency stability of islanded power systems," *Proceedings of the 2<sup>nd</sup> IEEE International Conference on Power and Energy (PECon 08)*, pp. 112-116, 2008.
- [2] C. Voumas, "Technical summary on the Athens and southern Greece blackout of July 12, 2004," National Technical University of Athens Report, 2004.
- [3] M. Sforna, M. Delfanti, "Overview of the events and causes of the 2003 Italian blackout," *Proceedings of the IEEE Conference on PES Power System and Exposition*, pp. 301-308, 2006.
- [4] W.A. Elmore, *Protective Relaying, Theory and Applications*, 2<sup>nd</sup> Edition, Marcel Dekker, 2004.
- [5] B. Delfino, S. Massucco, A. Morini, P. Scalera and F. Silvestro, "Implementation and comparison of different under frequency load shedding schemes," *Proceedings of the Power Engineering Society Summer Meeting*, vol. 1, pp. 307-312, 2001.
- [6] H. Seyedi and M. Sanaye-Pasand, "Design of new load shedding special protection schemes for a double area power system," *American Journal of Applied Sciences*, pp. 317-327, 2009.
- [7] V.V. Terzija "Adaptive under-frequency load shedding based on the magnitude of the disturbance estimation," *IEEE Transactions on Power Systems*, vol. 21, pp. 1260-1266, 2006.
- [8] H. Seyedi and M. Sanaye-Pasand, "New centralized adaptive load shedding algorithms to mitigate power system blackouts," *IET Proceeding on Generation, Transmission and Distribution*, vol. 3, no. 1, pp. 99-114, 2009.
- [9] U. Rudez and R. Mihalic, "Monitoring the first frequency derivative to improve adaptive under frequency load Shedding schemes," *IEEE Transactions on Power Systems*, vol. 26, no. 2, pp. 839-846, 2011.
- [10] P. M Anderson and M. Mirheydar, "A low order system frequency response model," *IEEE Transactions on Power Systems*, vol. 5, no. 3, pp. 720-790, 1990.
- [11] U. Rudez and R. Mihalic, "Analysis of under frequency load shedding using a frequency gradient," *IEEE Transactions on Power Delivery*, vol. 26, no. 2, pp. 565-575, 2011.
- [12] A. Li and Z. Cai, "A method for frequency dynamics analysis and load shedding assessment based on the trajectory of power system simulation," *Proceedings of the 3rd International Conference on Electric Utility Deregulation and Restructuring and Power Technology (DRPT)*, pp. 1335-1339, 2008.
- [13] D. Prasetijio, W.R. Lachs and D. Sutanto, "A new load shedding scheme for limiting underfrequency," *IEEE Transactions on Power Systems*, vol. 9, no. 3, pp. 1371-1378, 1994.
- [14] A.V. Kulkarni, W. Gao and J. Ning, "Study of power system load shedding scheme based on dynamic simulation," *Proceedings of the Conference on Transmission and Distribution and Exposition*, pp. 1-7, 2010.
- [15] P. Mahat, Z. Chen and B. Bak-Jensen, "Under frequency load shedding for an islanded distributed system with distributed generation," *IEEE Transactions on Power Delivery*, vol. 25, no. 3, pp. 911-918, 2010.
- [16] S. Lukas, I. Egido and L. Rouco, "Principles of a centralized UFLS scheme for small isolated power Systems," *IEEE Transactions on Power Systems*, vol. 28, no. 2, pp. 1779-1786, 2013.
- [17] A.D.L. Hau, "A general-order system frequency response model incorporating load shedding: Analytic modeling and applications," *IEEE Transactions on Power Systems*, vol. 21, no. 2, pp. 709-717, 2006.
- [18] M.A. Mitchell, J. P. Lopes, J.N. Fidalgo and J.D. McCalley, "Using a neural network to predict the dynamic frequency response of a power system to an under-frequency load shedding scenario," *Proceedings of the IEEE Conference on Power Engineering Society Summer Meeting*, pp. 346-351, 2000.
- [19] S. Lukas, I. Egido and L. Rouco, "Performance analysis of UFLS schemes of small isolated power systems," *IEEE Transactions on Power Systems*, vol. 27, no. 3, pp. 1673-1680, 2013.
- [20] M. Karimi, H. Mohamad, H. Mokhlis and A.H.A. Bakar, "Under-frequency load shedding scheme for islanded distribution network connected with mini hydro," *International Journal of Electrical Power and Energy Systems*, vol. 42, pp. 127-138, 2012.
- [21] G. Hung, C. Chang and C. Chen, "Automatic phase shift method for islanding detection of grid connected photovoltaic inverter," *IEEE Transactions on Energy*

*Conversion*, vol. 18, no. 1, pp. 169-173, 2003.

- [22] Md. Quamrul Ahsam, A. Chwdhury, S. Shahnavaz Ahmad, I. Bhuyan, M. Haque and H. Rahman, "Technique to develop auto load shedding and islanding scheme to prevent power system black out," *IEEE Transactions on Power Systems*, vol. 27, pp. 198-205, 2012.
- [23] N. Jenkis, R. Allan, P. Crossley, D.Kirdchen and G.

Strbac, *Embedded Generation Book*, London, 2000.

- [24] S. Ghassem Zadeh, R. Madani, H. Seyedi, A. Mokari and M. Bahram Zadeh, "New approaches to load shedding problem in islanding situation in distribution with distributed generation", *Proceedings of the Conference on Integration of Renewable into the Distribution Grid*, pp. 212-215, 2012.