



## POSSIBILITIES OF DRIVEABILITY AND FUEL CONSUMPTION IMPROVEMENT BY ADVANCED CONTROL POWER TRANSMISSION SYSTEM IN PASSENGER CAR

Andrzej Bieniek<sup>1</sup>, Jerzy Jantos<sup>2</sup>, Jarosław Mamala<sup>3</sup>

Opole University of Technology,

Faculty of Mechanical Engineering, Mikolajczyka 5, 45271 Opole, Poland

E-mails: <sup>1</sup> [abieniek@po.opole.pl](mailto:abieniek@po.opole.pl); <sup>2</sup> [jantos@po.opole.pl](mailto:jantos@po.opole.pl); <sup>3</sup> [mamala@po.opole.pl](mailto:mamala@po.opole.pl)

Received 11 April 2007; accepted 10 September 2007

**Abstract.** The correct work of a power transmission system for the sake of a car motion properties, fuel consumption and pollution emission, requires proper control of an engine and power transmission system. This problem becomes especially significant in the case of automation of the power transmission system and particularly regarding the system of constant gear ratio change between the engine and drive wheels (Continuously Variable Transmission), examined in the paper. This control is based on friction degree conditions estimation between metal belt and the transmission wheels. This paper also describes the experimental results of bench test and road test and applying of different control strategies.

**Keywords:** control power transmission system, continuously variable transmission, belt, driveability.

### 1. Introduction

One of the fundamental tasks undertaken by engineers in the branch of automobile construction has been the increase and optimization of history of driving force in wheels throughout the process of acceleration. An increase in the driving force of a car will promote safety on the roads and improve the comfort of driving. However, the full optimization of driving force is not possible in the case of classical power transmission systems in which the leading role in controlling power transmission systems is taken by the human – driver. This situation is the case for classical power transmission systems with the manual system of transmission control. In this case the human constitutes the determinant of the parameters of power transmission system control, while the car construction engineers are only capable of optimizing the operation of such a system with a view to optimization of combustion engine operation under specified parameters. This optimization most commonly involves throttle opening, fuel injection intervals and ignition advance angle in such a way which ensures adequate conditions for the process of combusting air-fuel mixture. Simultaneously, the selection of transmission ratio is the role of the driver, which is conducted in a subjective way for the purpose of adapting vehicle speed to the instantaneous traffic conditions, thus imposing a specific rotational speed of the engine. This way of control is a long way apart from optimum.

From the analysis of the European automotive market it results that the group of vehicles with manual drive systems is still dominant. Simultaneously, a fall in the

number of such vehicles can be discerned [1]. However, a systematic rise in the number of vehicles equipped with automatic power transmission systems can be observed. For such systems the process of optimizing the history of driving force in wheels is possible through an appropriate selection of transmission and load of the power transmission system regardless of driver's intentions. This control is possible in automatic mechanical transmissions (AMT) and continuously variable transmission (CVT) systems. Continuously variable transmissions are the solutions which have attracted attention in the recent years, mainly as a result of unlimited selection of transmission within a range and continuity of torque transmission from the engine to the wheels. The CVT powertrain applied in passenger cars most commonly apply the phenomenon of friction for the purpose of transmitting torque. The control of this process combined with the simultaneous control of engine parameters enables the construction of integrated control systems. The current paper presents the results of experimental research for the purpose of assessing the effects of control on the driving force and fuel consumption in a passenger car equipped with a CVT power transmission system.

### 2. Test object

The test object was the passenger car: Fiat Punto II Speed Gear (Fig. 1).

The car *Fiat Punto II Speed Gear* has been equipped with an automatic power transmission system with belt continuously variable transmission. Basic parameters of the car are presented in Table.



Fig. 1. Test car and bench test

Basic parameters of the examined car and its power transmission system

No.	Parameter	Value, description
1	Total mass of the vehicle	1200 kg
2	Front area	2.12 m <sup>2</sup>
3	Engine	SI PFI
4	Power /speed	59 kW / 5000 rpm
5	Torque / speed	114 N·m / 4000 rpm
6	Shape factor	0.32
7	Transmission type	Fuji HyperM6
8	Wheel radius	0.29 m
9	CVT ratio interval	0.442 – 2.432
10	Final drive ratio	4.647
11	Engine controller	Bosch MPI ME7.3
12	Engine displacement	1.242 dm <sup>3</sup>

The testing described in this paper was performed on a certified car bench test in accordance with the recognized NEDC test. Tests were performed according to the Directive 70/220/EEC, amended with successive directives including the Directive 2002/80/EC as of October 3, 2002 and the Regulation 83/05/ECE of the European Economic Commission, UN agenda, assumed to be used in Poland.

### The control unit modification

In order to perform the testing it was indispensable to modify the transmission system. The series production Fuji Hyper M6 CVT has only one pressure sensor in the secondary hydraulic circuit. The same one has been mounted in the primary hydraulic circuit (Fig. 2, a). In order to calculate thrust forces ratio, the measurement of hydraulic pressure in primary and secondary pulleys was necessary to take.

The control and measurement system applied for the testing included a portable computer with Daqbook 100 interface programmed in DASyLab 7.0 environment. The control screen is presented in Fig. 2, b.

The power transmission system was modified in such a way that it was possible to measure the following parameters: position and speed of change of accelerator pedal, position and speed of throttle opening in manifold, rotational speed of engine, rotational speed of primary and secondary wheels and pressure in primary and secondary wheels.

The primary quantities for the control of drive system include: throttle opening in manifold and thrust force in primary wheel of the transmission exerted through pressure change in this wheel.

Such a solution provided for the control of driving force transferred to wheels of the vehicle.



a)



b)

Fig. 2. The primary hydraulic pressure sensor (a); control and measurement screenshot (b)

### 3. Testing undertaken

#### 3.1. Advanced control system

The up-to-date vehicles equipped with more and more complex drive systems are becoming more common in Europe. In 2003 the share of vehicles with automatic power transmission system amounted to 21 % of the globally purchased new cars. An ever greater role is played by the cars equipped with CVT powertrain. For these cars the fundamental traction and economic parameters including acceleration and fuel consumption are favourable (Fig. 3).

The concept of advanced system of driving system control is based on ensuring in every circumstances the adequate driving force in driving wheels, which secure favourable traction and economic parameters. The driving force developed in CVT powertrains depends among others on the thrust force in transmission wheels, which results from the operation of oil pressure in the wheels of the transmission. For the purpose of gaining high efficiency and ensuring long transmission life this force must be adjusted, as the metal friction parts may very easily get damaged in the case when friction forces occur. The selection of appropriate thrust force constitutes one of the most demanding tasks. The large diversification of operating conditions of the transmission, the involvement of numerous disturbances and difficulties in the measurement of some of quantities result in large uncertainty of determining the optimum oil pressure in transmission wheels [2–5]. Due to this, a considerable surplus of thrust force is applied (under the full load this surplus may amount to ca 30 % of the calculated minimum thrust force). The tests conducted by the current authors indicate that the operation of transmission under low load results in a greater surplus of thrust force.

Despite this, a large number of instances when transmission was damaged as a result of excessive slip of collaborating parts is familiar.

The papers by [3, 4, 6–10] present a mathematical model used for the calculation of required thrust force and define the operating conditions of the transmission in particular with regard to the condition of friction connection between belt and transmission wheels, as shown in Fig. 4.

The assessment of the condition of the transmission is possible as a result of the observation of quotient of thrust forces occurring in wheels. The analysis of positions of measurement points in this quotient in the area defined by the mathematical model enables a relative estimation of the surplus of thrust force. As a result, it provides for the control of pressure in transmission wheels which ensures both the demanded transmission ratio, transmission ratio derivative [11, 12] and the operation of transmission with a minimum surplus of this force.

Fig. 5 presents the system for pressure control in transmission wheel. The optimization of the control strategy and the replacement of empirical control scheme with a system including feedback further supported with a mathematical model will allow an improvement of the

performance of the power transmission system with CVT transmission.

#### 3.2. Effect of thrust force on transmission force and fuel consumption

In order to determine the effect of thrust force on traction characteristics and fuel consumption road tests were undertaken along with chassis bench test with the aim of recording the characteristics of the modernized power transmission system.

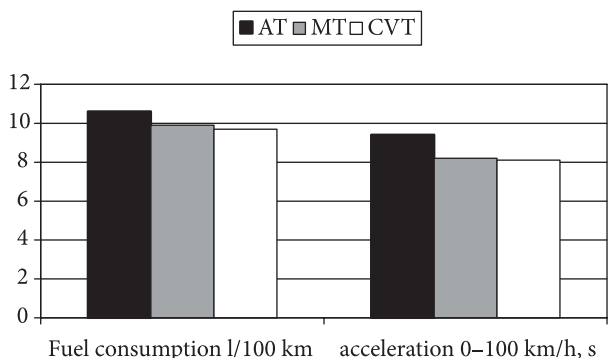

Fig. 3. Fuel consumption (MVEG cycle) and dynamic properties (0–100 km/h) comparison in Audi A6 2.8 vehicle equipped with AT, MT and CVT [13]

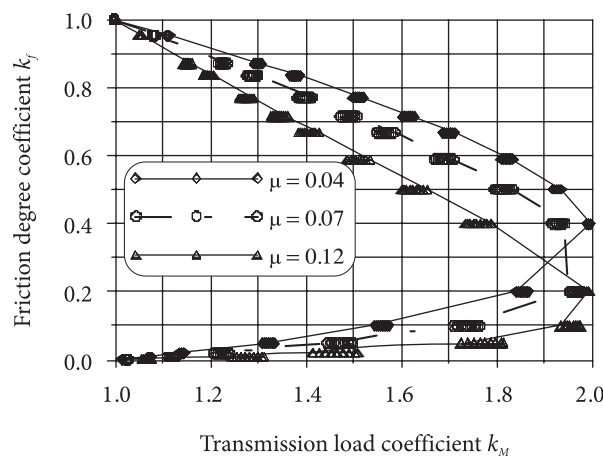

Fig. 4. Operating condition estimation of the CVT transmission (mathematical model)[9]

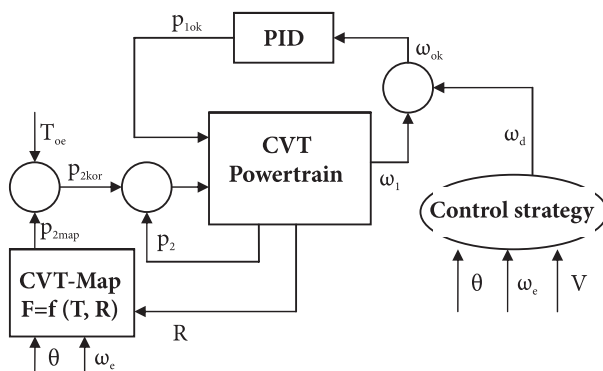

Fig. 5. Schematic diagram of standard control system of CVT powertrain

In the preliminary tests the measurements of thrust force variation in the transmission wheels were performed with the aim of characterizing their effect on the operating parameters of a power transmission system including CVT powertrain. During bench tests the effect of thrust force on the ability of achieving maximum car speed was determined.

Fig. 6 shows that at maximum vehicle speed test the engine rotational speed by enlarged and nominal thrust force has almost the same value.

As it is indicated in Fig. 7, the increase in thrust force results in a fall of maximum car speed. Despite the relatively low absolute value of this fall, it is equal to a 2 kW increase in power losses in the powertrain, which result from an increased value of thrust force.

In order to test the value of thrust force on the operating parameters of power transmission system bench test was undertaken in NEDC cycle. The history of driving force on wheels is determined by the defined profile of cycle speed; hence, it is repeatable in character. The change in the thrust force allows the determination of its effect on selected parameters of transmission gear performance with a fixed history of driving force, which results in conclusions about power transmission system.

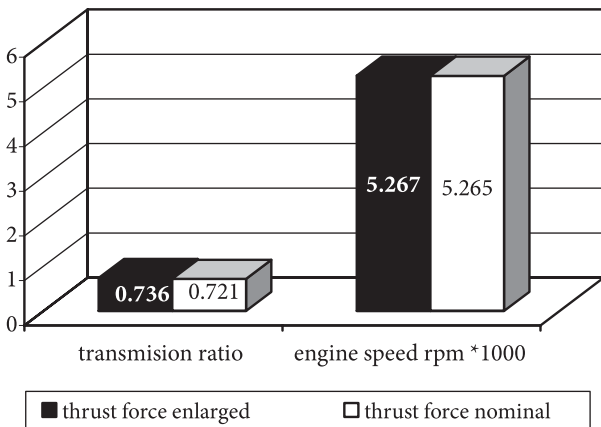

Fig. 6. Powertrain operating condition at maximum speed test

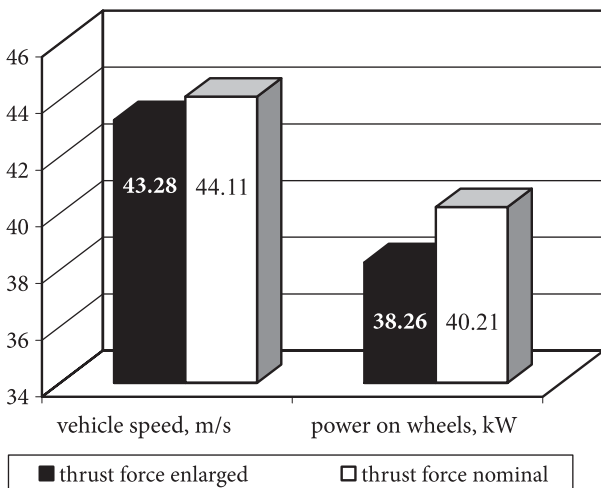

Fig. 7. Power on vehicle wheels at maximum speed test

It was indicated that there is a relevant effect of the thrust force value on transmission ratio (Fig. 8) and value of throttle opening (Fig. 9).

The increase in transmission ratio and throttle opening does not result in a concurrent increase in the driving force measured on the wheels. Hence it can be concluded that it results in an increase of losses on the transmission having its origin in the increased friction force between the belt and transmission wheels. Concurrently, fuel consumption in NEDC cycle with an excess of thrust force leads to the deterioration of the performance. With a lower value of thrust force a reduction of 8.42 % was recorded as to fuel consumption in NEDC cycle, while for EUDC cycle it amounted to roughly 10 % (Fig. 10).

Such a considerable reduction in fuel consumption can be attributed both to an improvement in transmission performance with the use of a lower thrust force and

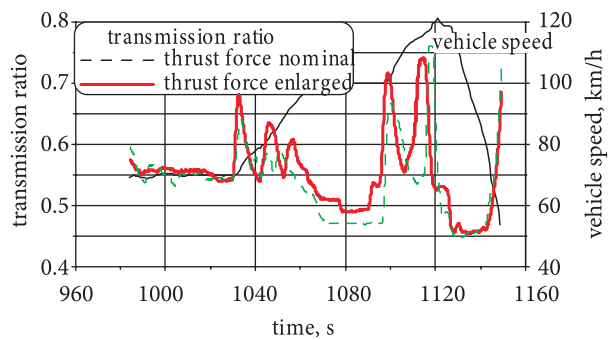

Fig. 8. Transmission ratio course at EUDC cycle

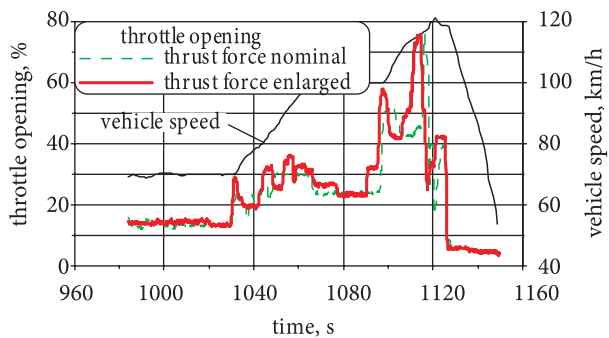

Fig. 9. Throttle opening course at EUDC cycle

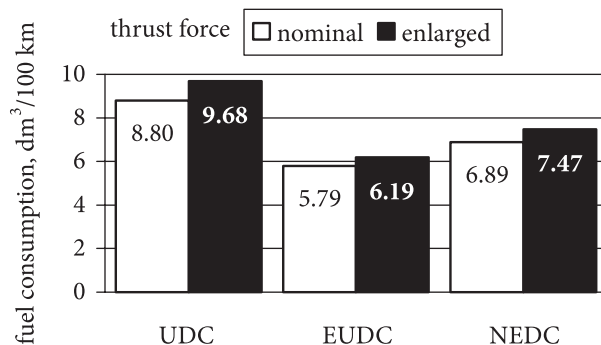

Fig. 10. Fuel consumption by drive cycle (bench test)

more favourable operating indicators of the operation of the whole power transmission system including the engine and transmission itself.

#### 4. Conclusions

As it is indicated on the basis of the conducted testing and research, the advanced control of thrust force in wheels of CVT powertrain allows a compromise between conflicting requirements involving the improvement of dynamic properties accompanied by a concurrent reduction of fuel consumption. In order to apply the novel algorithms supported with an elaborated mathematical model it is necessary to introduce only insignificant modifications to the design. Further modification of the control algorithms will allow the application of the developmental potential of CVT powertrain. This optimization will apply to improvement of economical and ecological parameters together with dynamic properties. As a result, safety on the roads will improve.

#### References

1. BEHRENROTH, J.; GUETER, C. Aspekte zur Systemarchitektur, Triebstrangregelung und Abstimmung – wie haben Kundenerwartung die Entwicklung des CVT für den neuen Mini beeinflusst. In *CVT 2002 Congress Munich*, 7–8 October 2002, VDI-Berichte 1709, S. 195–210.
2. IDE, T. Effect of power losses of metal V-Belt CVT components on the fuel economy. In *International Congress on Continuously Variable Power Transmissions CVT'99 Eindhoven 1999*, p. 93–98.
3. RENIUS, K. Th.; SAUER, G. *Optimale Ketteneinspannung stufenloser Umschlingungsgetriebe*. 1996 Sonderforschungsbericht 365 Teilprojekt C1, S. 261–287.
4. SAUER, G. *Grundlagen und Betriebsverhalten eines Zugketten-Umschlingungsgetriebes*. VDI Verlag, 1996, No. 293.
5. STÖCKL, B. Development of a pressure-controlled clamping system for continuously variable belt and chain transmissions. In *CVT 2002 Congress Munich*, 7–8 October 2002, VDI-Berichte 1709, p. 571–582.
6. BIENIEK, A. Neue Methode zur Bestimmung von Reibungsabwicklungsgrad des Stufenloses Umschlingungsgetriebe. In *International Symposium "Advances in Mechanical Engineering"*, Gdańsk, 2006, S. 27–38.
7. BIENIEK, A. Analytisches Modelbildung der Stufenloses Umschlingungsgetriebe. In *International Symposium "Advances in Mechanical Engineering"*, Gdańsk, 2006, S. 39–50.
8. BIENIEK, A.; JANTOS, J. Analytical model of continuously variable transmission. In *International Congress Motor Vehicles & Motors*, Kragujevac, 2006, paper No. 20060074, p. 1–6.
9. BIENIEK, A. Analysis of transmission load and frictional conditions in continuously variable transmission. In *International Congress Motor Vehicles & Motors*, Kragujevac, 2006, paper No. 20060064, p. 1–6.
10. JANTOS, J.; MAMALA, J.; BIENIEK, A. Estimation of friction degree in the continuously variable transmission. In *International Conference "Power Transmission '06"*, Novi Sad, 2006, p. 377–380.
11. JANTOS, J. Transmission ratio derivative value and driveability of the vehicle with CVT. *Archives of Transport*, 2001, Vol. 13, p. 47–59.
12. SERRARENS, A.; VELDPAUS, F. *Driveability Assessment of a CVT-powertrain with mechanical Torque Assist*, FISITA World Automotive Congress, Helsinki, 2002, No. F02V067.
13. NOWATSCHIN, K.; HOMMES, G.; FLEISCHMANN, H.-P.; FAUST, H.; GLEICH, T.; FRIEDMANN, O. Multitronic – Das neue Automatikgetriebe von Audi -Teil I. *Automobiltechnische Zeitschrift*, 2000, 102, No. 7/8, S. 548–553.

#### Acknowledgement

The hereby scientific study was supported by a grant from Polish State Committee for Scientific Research in the years 2005–2008 as a research project.