

“Does permit trading minimize cost under an average pollution target?”

AUTHORS

Sergey S. Rabotyagov
Hongli Feng

ARTICLE INFO

Sergey S. Rabotyagov and Hongli Feng (2010). Does permit trading minimize cost under an average pollution target?. *Environmental Economics*, 1(1)

RELEASED ON

Friday, 05 November 2010

JOURNAL

"Environmental Economics"

FOUNDER

LLC “Consulting Publishing Company “Business Perspectives”



NUMBER OF REFERENCES

0



NUMBER OF FIGURES

0



NUMBER OF TABLES

0

© The author(s) 2021. This publication is an open access article.

Sergey S. Rabotyagov (USA), Hongli Feng (USA)

Does permit trading minimize cost under an average pollution target?

Abstract

Emission permit trading is increasingly being applied to pollution control. Pollution targets are sometimes set as average (or expected) values. We investigate whether the least cost property of permit trading programs is still valid with an average target. In the standard permit trading theory, trading ratio is set equal to the delivery coefficient and the total permit number equal to the given pollution target. If this is the case under an average target, we show that least cost is no longer guaranteed. Under an average target, the regulator minimizes cost by achieving a balance between the total permit effect and deadweight loss effect. The latter is always negative. The former can be increased by allowing more (less) pollution when abatement cost is high (low). Departing from the well established result on trading that information on abatement cost is not needed to achieve the least cost, we found that such information is useful under an average pollution target.

Keywords: delivery coefficient, average pollution target, fixed pollution target, permit trading, total permit number, trading ratio.

JEL Classification: Q58, D02.

Introduction

A highly celebrated property of emissions trading markets is that decentralized decisions made by firms will achieve a preset pollution target at the least possible cost and no information on the firms' abatement costs is required to achieve this outcome (Baumol and Oates, 1988; Montgomery, 1972)¹. Montgomery (1972) demonstrated that this property extends to the class of non-uniformly mixed pollutants, pollutants whose damages differ based on their location. He showed that if the regulatory authority allows firms to trade emissions according to the ratio of delivery coefficients (the effect that a source's emissions have on resulting pollution level) and sets the total permit number equal to the given pollution target, the least cost property is retained.

The basic model underlying these findings assumes that the regulator's goal is to minimize the cost of meeting a single fixed environmental standard. In other words, the pollution target of the permit trading system is given as a fixed number. This is the standard case examined in most permit trading literature. Many real world permit trading schemes also set a fixed pollution target. However, there are also situations where the pollution target is essentially given as an average target. There are two notable examples. One is bankable permit trading systems, where firms are allowed to borrow or bank permits across time periods. Permit banking occurs when permits authorized for the current period are saved for use in subsequent periods; permit borrowing occurs when permits authorized for some future period are instead used in the current period. Suppose firms are issued the same number of permits

for each period of time, then banking and borrowing allows firms to achieve the pollution target on average over time, as opposed to in each period of time. This flexibility has been shown to have reduced costs in several trading programs, e.g., the lead phase out program and the sulfur trading program (Newell and Rogers, 2003; Burtraw et al., 2005).

Another example is the emerging water quality trading programs. According to the US Clean Water Act, Total Maximum Daily Load (TMDL) must be developed for a water body with impaired water quality. Currently, the US Environmental Protection Agency lists nearly 39,000 impaired waterways throughout the nation (USEPA, 2007). In the TMDL process, the sources of water quality impairment in a water body are identified and the loading reduction responsibilities allocated among the various sources. Even though it is called TMDL, many of the loadings are specified in terms of annual average loadings. In this sense, the TMDL is given as an average target. Many watersheds have established water quality trading programs or are exploring trading as a policy instrument to implement the TMDL targets in a cost-effective way (Hoag and Hughes-Popp, 1997; USEPA, 2004; Woodward et al., 2002).

In this paper, we examine the cost-minimizing property of a permit trading system where the environmental goal is set as an average pollution level. Through a simple model, we found that, to minimize costs, modification of the standard trading system in the following aspects is required. First, the optimal total permit number does not necessarily equal the given pollution target. Second, it is not necessarily optimal to set trading ratios equal to the simple ratio of delivery coefficients—the basic Montgomery (1972) solution. Instead, the regulator can lower expected cost by including some information on abatement cost in setting the trading ratio.

© Sergey S. Rabotyagov, Hongli Feng, 2010.

¹ The total permit quantity can be set at the socially efficient level, a legally mandated requirement, or any other level deemed appropriate by the regulator.

These somewhat surprising findings come directly from the fact that our regulator's objective function is specified in average terms: it minimizes expected cost subject to an average pollution level. This allows the regulator flexibility that is not present when a fixed level of emissions must be met. In particular, the regulator can design a trading system that will incorporate information, albeit incomplete, on firms' abatement costs. In such a trading system, if costs are unexpectedly high (low), the resulting pollution levels tend to be higher (lower) than they would be without this flexibility. By allowing pollution level to fluctuate with costs, the regulator can lower total expected abatement costs, while ensuring that the environmental goal is still being met on the average.

Trading ratio and total permit number have been the subject of quite a few studies, e.g., Kling and Rubin (1997), Yates and Cronshaw (2001), Feng and Zhao (2003), and Innes (2005). Our paper differs from previous studies in our focus of the pollution target given in average terms. We do not examine whether the regulator should have the freedom to design a permit market that allows the aforementioned flexibility. Instead, we investigate the properties of a trading system that does have an average pollution target. The Montgomery (1972) result that cost minimization can be achieved without the regulator knowing firms' abatement cost has very strong appeal in policy design. The main purpose of this paper is not to advocate an alternative trading system. Rather, we intend to contribute to the literature by showing why the standard result does not hold when pollution target is given as an average value.

In the rest of the paper, we present the basic model of firms' behavior under a tradable emissions program and the regulator's problem. Then, we examine the optimal permit market design when the delivery coefficient is known. We also consider the case where the delivery coefficient is uncertain. This feature is typically viewed as a characteristic of nonpoint sources. However, there are other situations where the true impact of emissions from a source is known with less than perfect certainty, e.g., air sheds where dispersion of particulates depend on stochastic weather conditions. Final remarks and conclusions complete the paper in the final Section.

1. Model setup

Suppose there are two firms acting as sources of emissions and the environmental impacts of the two firms' emissions can differ. Specifically, we assume that the impact of the first firm on the resulting pollution level is such that one unit of Firm 1's emissions increases the resulting pollution level by one

unit. The impact of Firm 2 is described by the delivery coefficient d , that is, one unit of Firm 2's emissions increases the resulting pollution level by d units. When emissions from the two firms have the same environmental impact, we have $d=1$. The delivery coefficient can be thought of as describing the relative environmental impact of the two firms' emissions. Specifically, the total resulting pollution level is $e_1 + de_2$, where e_i for $i=1,2$ represents Firm i 's emissions. In this Section we model the situation in which the delivery coefficient is fixed and known by the regulator. Later, we extend our analysis to the case where the delivery coefficient is uncertain.

The abatement cost function for Firm i is $C_i(e_i^0 - e_i; \theta_i)$, where, for $i=1,2$, e_i^0 represents the initial (unregulated) emissions level for Firm i and $e_i^0 - e_i$ represents the abatement of Firm i after the implementation of a permit trading program. The abatement cost function is assumed to be increasing and convex in abatement, that is, $C'_i > 0$ and $C''_i \geq 0$. The parameter (θ_i) in the cost function captures the uncertainty regarding the costs of pollution abatement on the regulator's side. We assume that the regulator has some, albeit incomplete, information on abatement costs. Formally, the regulator, when making decisions on the parameters of the permit market, knows only the distribution of θ_1 and θ_2 : the means (zero), variances (σ_1^2 and σ_2^2), and covariance, $(\text{cov}(\theta_1, \theta_2))$. However, when making emissions decisions, firms know θ_1 and θ_2 .

To avoid confusion, we clarify several concepts that are related to the total amount of pollution allowed in a permit trading program: average pollution target, fixed pollution target, total permit number, and actual pollution level. First, a trading program can either use an average pollution target or a fixed target defined as follows:

$$E[e_1 + de_2] \leq \bar{P}_{average} \quad (\text{average pollution target}) \quad (1)$$

$$e_1 + de_2 \leq \bar{P}_{fixed} \quad (\text{fixed pollution target}) \quad (2)$$

The constraints require that total pollution not exceed the preset target, either given as an average value or a fixed number. In equation (1), average pollution target is defined as the expectation of total pollution level. Another relevant constraint defines the restriction at the permit market:

$$e_1 + te_2 \leq \bar{P}_{permit} \quad (\text{permit market constraint}) \quad (3)$$

where t is the trading ratio for the emissions of the two firms, meaning that 1 unit of Firm 2's emissions is equivalent to t units of Firm 1's emissions; and \bar{P}_{permit} is the total permit number, denominated in terms of Firm 1's emissions. This constraint requires that total emissions (weighted by the trading ratio) not exceed the total permit number. Note that the firms are only concerned with the permit market constraint while the regulator's goal is to restrict total pollution to the preset average target or fixed target. Finally, the actual realization of pollution given firms' emission decisions is as follows:

$$e_1 + de_2 \leq \bar{P}_{actual} \quad (\text{actual pollution}) \quad (4)$$

Comparing equations (1)-(2) with (3), we see that actual pollution will equal to the target under a binding fixed target. By contrast, only the mean of actual pollution will equal to a binding average target.

1.1. Firms' emissions decisions in a permit trading market. Should an emissions trading program be introduced? The firms will face the permit market constraint in equation (3). Suppose the initial permit endowments allocated to Firm i (and denominated in Firm 1's emissions) are \bar{e}_i for $i=1,2$; and $\bar{e}_1 + t\bar{e}_2 = \bar{P}_{permit}$. Through trading, both firms can hold the permits denominated in terms of another firm's emissions, and the trading ratio is used to convert between the two types of permits. The trading program requires that each firm's actual emissions do not exceed its holding of permits. Let y_i , denominated in terms of Firm i 's emissions, denote the equilibrium quantity of permits traded. Specifically, y_i is the permit quantity sold by Firm i and purchased by the other firm. Assuming that each firm takes permit prices as given, then Firm 1's problem would be as follows:

$$\begin{aligned} \min_{e_1, y_1, y_2} & C_1(e_1^0 - e_1) - p_1 y_1 + p_2 y_2 \\ \text{subject to} & e_1 + y_1 - t y_2 \leq \bar{e}_1. \end{aligned} \quad (5)$$

Firm 2's problem is similar. Solving for the firms' problems, it is well-known that market equilibrium requires that: $MC_i \equiv C'_i(e_i^0 - e_i^*) = p_i$, for $i=1,2$; and $p_1/p_2 = 1/t$. This implies that the ratio of permit prices must be equal to the trading ratio. Otherwise, costless arbitrage opportunities would be available to firms. Then, we have:

$$\frac{MC_2}{MC_1} = t. \quad (6)$$

From equation (6) and the permit market constraint in equation (3), we can solve for firms' optimal

emissions as a function of t and \bar{P}_{permit} , that is, $e_i^*(t, \bar{P}_{permit}; \theta_1, \theta_2)$ for $i=1,2$. When emissions decisions are made in the permit trading market, firms have complete information on their costs, i.e., θ_1 and θ_2 are known with certainty. Equation (6) indicates that the results of the permit trading market are such that the ratio of marginal costs equals the trading ratio. However, with complete information on θ_1 and θ_2 , we know from Montgomery (1972) that social efficiency requires $t = d$, resulting in

$$\frac{MC_2}{MC_1} = d. \quad (7)$$

Any gains in setting t at a level other than d in a trading program would need to be weighed against the efficiency loss of not attaining the equality in equation (7). This is an issue we will return to in Section 2.

1.2. The regulator's problem. Our paper focuses on the design of permit trading programs, where the goal is to minimize the cost to reach a given pollution target. Given a fixed pollution target, the regulator must set the trading ratio equal to d and $\bar{P}_{permit} = \bar{P}_{fixed}$. Otherwise, there is no guarantee that the target will be met. The reason is as follows. From equations (2) and (3), we know that

$$\bar{P}_{permit} - \bar{P}_{fixed} = (t - d)e_2. \quad (8)$$

If $t = d$, then $\bar{P}_{fixed} = \bar{P}_{permit}$, regardless of the value of e_2 . However, if the regulator is to set $t \neq d$, then it needs to adjust \bar{P}_{permit} as well so that the fixed pollution target is met. The appropriate adjustment needs complete information of e_2 , which is assumed unknown to the regulator when designing the permit market (due to uncertain abatement costs).

Given an average target, the regulator potentially has the flexibility of setting the parameters of the permit trading system (t and \bar{P}_{permit}) to achieve the expected pollution target at the least cost. To see this, we first note that as long as the program is intended to reduce emissions, both the average pollution constraint in equation (1) and the market permit constraint in equation (3) will be binding. Then, by taking difference of the two constraints, we obtain:

$$\bar{P}_{permit} - \bar{P}_{average} = E[e_2](t - d). \quad (9)$$

Thus, if the regulator sets $t \neq d$, it can adjust \bar{P}_{permit} to guarantee that the average target will be met. The

realization of total pollution can be higher or lower than the given average target depending on firms' abatement costs and the values the regulator chooses

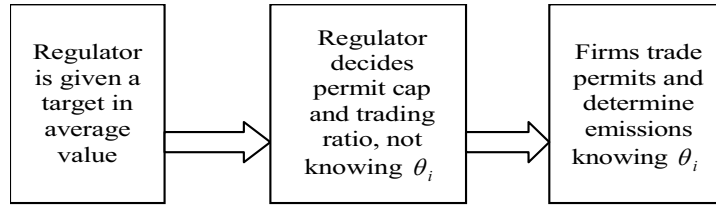

Formally, we can set up the regulator's problem of cost-minimization as follows,

$$\min_{t, \bar{P}_{\text{permit}}} = E [TC(t, \bar{P}_{\text{permit}})] \equiv E [C_1(e_1^*(t, \bar{P}_{\text{permit}}; \theta_1, \theta_2) + C_2(e_2^*(t, \bar{P}_{\text{permit}}; \theta_1, \theta_2)))] \quad (10)$$

Note that firms emissions decisions, $e_i^*(t, \bar{P}_{\text{permit}}; \theta_1, \theta_2)$ for $i=1,2$, are incorporated into the regulator's program. We next explore the optimal trading ratio and total permit cap.

2. Optimal permit trading ratio and total permits under an average pollution target

For tractability, we assume that one firm faces a linear abatement cost function while the other faces an increasing convex abatement cost function, as specified below:

$$C_1(e_1^0 - e_1, \theta_1) = (a + \theta_1)(e_1^0 - e_1), \quad (11)$$

$$C_2(e_2^0 - e_2, \theta_2) = (b + \theta_2)(e_2^0 - e_2) + c(e_2^0 - e_2)^2. \quad (12)$$

As will be clear later, this linear and quadratic setup is sufficiently rich to generate critical insights while remaining simple enough for intuitive discussion. In equation (11) we assume that $a^2 - \sigma_1^2 > 0$, that is, the mean of Firm 1's marginal abatement cost (which represents the deterministic part) dominates the variance (which represents the stochastic part). This assumption ensures that the second order condition for the problem in equation (10) is satisfied. With the above cost functions, we can derive firms' optimal emissions from equations (6) and (3):

$$e_1^*(t, \bar{P}_{\text{permit}}; \theta_1, \theta_2) = \frac{2c(\bar{P}_{\text{permit}} - e_2^0 t) - (b + \theta_2)t + t^2(a + \theta_1)}{2c}, \quad (13)$$

$$e_2^*(t, \bar{P}_{\text{permit}}; \theta_1, \theta_2) = \frac{2ce_2^0 + (b + \theta_2) - t(a + \theta_1)}{2c}. \quad (14)$$

It is straightforward to solve the optimization problem (10) with (13)-(14)¹. First, we obtain the optimal trading ratio:

for $t, \bar{P}_{\text{permit}}$. The following chart illustrates the decision process and the occurrence of events:

$$t^* = d + \frac{1}{a^2 - \sigma_1^2} (d\sigma_1^2 - \text{cov}(\theta_1, \theta_2)). \quad (15)$$

Plugging t^* into equation (9), we can derive the optimal permit cap. We see from equations (9) and (15), if the regulator had complete information on θ_1 and θ_2 , then the optimal trading ratio would be set equal to the delivery coefficient, i.e., $t^* = d$, and the total permit number allocated to firms would equal the pollution target the regulator sets out to achieve, i.e., $\bar{P}_{\text{permit}}^* = \bar{P}_{\text{average}}$. However, in general, such setup will not minimize cost. Note that $a^2 - \sigma_1^2 > 0$. Thus, if θ_1 and θ_2 are negatively correlated, then $t^* > d$. We can still have $t^* > d$ when θ_1 and θ_2 are positively correlated and the correlation is relatively small compared to $d\sigma_1^2$. Otherwise, $t^* \leq d$. In our discussions, we will focus on the case with $t^* > d$. The other case can be analyzed similarly.

We next show how actual pollution fluctuates around the average target when $t^* \neq d$ and how the average target is ensured to be satisfied. From equations (3)-(4) we can derive:

$$\bar{P}_{\text{permit}} - P_{\text{actual}} = e_2(t - d). \quad (16)$$

Thus, if $t > d$, then the actual pollution will be less than the permit allocated. This is because 1 unit of Firm 2's emissions contributes d units to total actual pollution; but 1 unit of Firm 2's emissions needs t units of permits in the permit market constraint. Taking the difference of equations (9) and (16), we have,

$$P_{\text{actual}} - \bar{P}_{\text{average}} = (t - d)(E[e_2] - e_2), \text{ and}$$

$$E[P_{\text{actual}} - \bar{P}_{\text{average}}] = 0. \quad (17)$$

Thus, for any given t , how actual pollution level deviates from the average target is determined by how e_2 deviates from its mean². Regardless of the

¹ The problem is a standard optimization problem with one constraint, and so the details on the derivation of the solutions are not presented. To simplify our discussions, interior solutions are assumed throughout the paper.

² The reason that e_1 does not appear in equation (17) is that both the permit constraint (equation (3)) and the actual pollution (equation (4)) have the same weight on e_1 . This is not the case for e_2 .

fluctuations, on average the pollution target will be met. With the optimal solution for e_2 as given in equation (14), we can derive a more specific version of equation (17):

$$P_{actual} - \bar{P}_{average} = (t - d) \frac{t\theta_1 - \theta_2}{2c}. \quad (18)$$

Not surprisingly, the realization of actual pollution depends on the abatement costs of both firms. Next, we explain how abatement cost can be lowered through the flexibility afforded by an average target.

2.1. The total pollution effect and the deadweight loss effect. To see the effects on abatement cost of

$$TC(d, \bar{P}_{average}) - TC(t, \bar{P}_{permit}) = \underbrace{TC(d, \bar{P}_{average}) - TC(d, P_{actual})}_{total\ pollution\ effect} + \underbrace{TC(d, P_{actual}) - TC(t, \bar{P}_{permit})}_{deadweight\ loss\ effect}, \quad (19)$$

where \bar{P}_{actual} is the actual pollution level resulting from a trading program with (t, \bar{P}_{permit}) , that is:

$$P_{actual} = e_1^*(t, \bar{P}_{permit}) + de_2^*(t, \bar{P}_{permit}) = (d, P_{actual}) + de_2^*(d, P_{actual}). \quad (20)$$

In other words, a trading program with parameters (t, \bar{P}_{permit}) results the same pollution level as a trading program with parameters (d, P_{actual}) . The *total pollution effect* represents the cost difference that is due to the deviation of total pollution level from the benchmark program. This deviation is given by equation (18). The *deadweight loss effect* is directly linked to the use of a trading ratio that is not equal to the delivery coefficient, which leads to a sub-optimal allocation of emissions as we pointed out in Section 1.1. We refer to this effect as deadweight loss effect since it represents the extra cost incurred by using a trading ratio that deviates from the true rate of substitution (i.e., the true relative environmental impact of emissions).

With firms' emission decisions given by equations (13)-(14), we can derive the two effects as:

$$total\ pollution\ effect = \frac{1}{2c}(t-d)(a+\theta_1)(t\theta_1 - \theta_2), \quad (21)$$

$$deadweight\ loss\ effect = -\frac{1}{4c}(a+\theta_1)^2(t-d)^2. \quad (22)$$

Taking expectation, we have:

$$E[total\ pollution\ effect] = \frac{(t-d)}{2c} [t\sigma_1^2 - cov(\theta_1, \theta_2)] \quad (23)$$

and

$$E[deadweight\ loss\ effect] = -\frac{(t-d)^2}{4c} (a^2 + \sigma_1^2). \quad (24)$$

setting $t \neq d$ and $\bar{P}_{permit} \neq \bar{P}_{average}$, we use a benchmark permit trading program, where $t = d$ and $\bar{P}_{permit} = \bar{P}_{average}$. The total abatement cost in the benchmark trading program is denoted as $TC(d, \bar{P}_{average})$, which is derived by using firms' emission decisions under the program, i.e. $TC(d, \bar{P}_{average}) = C_1(e_1^*(d, \bar{P}_{average})) + C_2(e_2^*(d, \bar{P}_{average}))$.

The total abatement cost of other trading programs with different trading ratios and total permit numbers are defined similarly. We can break down the difference between the total cost of a trading program and the benchmark program as follows:

While equation (22) indicates that the expected total pollution effect can be either positive or negative, equation (23) implies that the expected deadweight loss effect is never positive. The two equations also imply that, the larger the variance of Firm 1 and the more the cost shocks are negatively correlated, the larger the effects of setting $t > d$ tend to be¹. In designing an optimal program, the regulator will seek to make the total pollution effect large and positive while keeping the deadweight loss effect relatively small. If $cov(\theta_1, \theta_2) < 0$, for expected total pollution effect to be positive, we must have $t > d$, The larger t is, the larger the total pollution effect. However, as t increases, the deadweight loss also increases. Thus, the regulator has to strike a balance between the two effects in order to minimize abatement cost to achieve the pollution target on average.

2.2. Intuition with graphical illustration. Figure 1 and Figure 2 (see Appendix) illustrate the intuition for the rationale behind $t \neq d$ and $\bar{P}_{permit} \neq \bar{P}_{average}$.

For simplicity, we set $d = 1$. In both Figures, the total length of the horizontal axis represents the total permits available and the solid downward sloping line is the marginal abatement cost curve of Firm 2 as emissions are increased (i.e., abatement is decreased). In Figure 1, the marginal abatement cost curve of Firm 1 is represented by the horizontal line that intersects with Firm 2's marginal cost curve at B^0 . When $t = d = 1$, $\bar{P}_{permit}^{t=1}$ is set equal to $\bar{P}_{average}$

¹ The variance of Firm 2's cost parameter does not appear in equations (22)-(23) because of the linear-quadratic functional forms assumed for abatement costs in the analysis. In this setup, equilibrium marginal abatement cost is determined by Firm 1 cost parameter.

by equation (9). Since $MC_1 = MC_2$ at B^0 , B^0 represents the permit market equilibrium, indicating the split of the emissions by the two firms with Firm 1's emissions read from the right (O_1) and Firm 2's emissions read from the left (O_2). When the trading ratio is set greater than the delivery coefficient two changes occur in Figure 1. First, the optimal total permit number increases to $\bar{P}_{permit}^{t>d}$ by equation (9), which is reflected by the shifting out of the right boundary of Figure 1 from O_1 to O_1' . Second, the new permit market equilibrium is represented by point B' , indicating a reduction in e_2 .

The two effects of setting $t > d$ on total abatement cost are illustrated by the shaded areas in Figure 1. Even when $t > d$, the true marginal abatement cost for Firm 1 is still the horizontal line a , not the horizontal line ta . However, firms make their decisions based on the latter, which leads to too few emissions (i.e., too much abatement) by Firm 2, resulting in a deadweight loss represented by the shaded triangle. The area of the triangle is given by equation (21). For the case illustrated in Figure 1 (with $\theta_1 = 0$ and $\theta_2 < 0$), we know from equation (17) that the actual total pollution is greater than the average pollution target. The savings in abatement cost from this increased pollution are represented by the area of the shaded rectangle and is also given by equation (20).

We use Figure 2 to illustrate how an optimally designed permit market can achieve a balance between the total pollution effect and the deadweight loss effect. Figure 2 is the same as Figure 1 except that it illustrates a case, where θ_1 can take on two values ($+\hat{\theta}_1 > 0$ and $-\hat{\theta}_1$) with equal probability, while θ_2 is held constant (specifically, $\theta_2 = 0$). For simplicity we assume $cov(\theta_1, \theta_2) = 0$. Consistent with equation (21), the Figure shows that there is a deadweight loss regardless of whether marginal abatement cost is high or low. The larger (smaller) shaded triangle represents the larger (smaller) distortion when the realization of Firm 1's marginal abatement cost is high, i.e., $\theta_1 = +\hat{\theta}_1$ (low, i.e. $\theta_1 = -\hat{\theta}_1$).

The total pollution difference between setting $t > d$ and $t = d$ is given by equation (17) and is represented by the width of the tall shaded rectangle for $\theta_1 = +\hat{\theta}_1$ and by the width of the short shaded rectangle for $\theta_1 = -\hat{\theta}_1$. When marginal cost is high (i.e. $\theta_1 = +\hat{\theta}_1$), setting $t > d$ will result in a cost

saving from less abatement (or higher than expected pollution level), the tall shaded rectangle. Similarly, when marginal cost is low (i.e. $\theta_1 = -\hat{\theta}_1$), setting $t > d$ will result in an extra cost from more abatement, the short shaded rectangle. When the difference between the cost saving and the extra cost is positive and greater than the sum of the deadweight losses, the regulator reduces total abatement cost with $t > d$, as illustrated in Figure 2.

3. Extension with uncertain delivery coefficient

The delivery coefficient is likely to be known for some pollutants (e.g. carbon dioxide), but there are many pollutants, where delivery coefficients will be uncertain. Many water pollutants are examples of the latter. The fate and transport of water pollutants is subject to both stochastic elements related to weather as well as scientific uncertainty concerning the physical diffusion processes. Our analysis can easily be extended to the case with uncertain delivery coefficient. Suppose the regulator knows the distribution of the delivery coefficient: its mean, $E(d) = \mu$, and its variance, $Var(d) = \sigma_d^2$. Furthermore, suppose the regulator also knows the covariances, if any, between the delivery coefficient and the cost parameters: $cov(d, \theta_1)$ and $cov(d, \theta_2)$. Such correlations may arise, for example, when weather affects the efficacy as well as the cost of abatement. With uncertain d , equations (9) and (15) are modified as:

$$t^* = \mu + \frac{1}{a^2 - \sigma_1^2} (\mu \sigma_1^2 + a \text{cov}(d, \theta_1) - \text{cov}(\theta_1, \theta_2)), \quad (25)$$

$$\bar{P}_{permit}^* - \bar{P}_{average} = E[e_2^*](t^* - \mu) + \frac{\text{cov}(d, \theta_2) - t^* \text{cov}(d, \theta_1)}{2c}. \quad (26)$$

The impact of uncertain delivery coefficient is reflected in the above two equations by $cov(d, \theta_1)$, $cov(d, \theta_2)$, and the use of the expected value of d . The optimal trading ratio moves in the same direction as $cov(d, \theta_1)$:

$$\frac{\partial t^*}{\partial \text{cov}(d, \theta_1)} = \frac{a}{a^2 - \sigma_1^2} > 0.$$

Suppose $cov(d, \theta_1) > 0$, that is, if the delivery coefficient is high, the marginal cost of abatement by Firm 1 also tends to be high. For given emissions, a high d means more total pollution. In order to reduce pollution to a fixed target, more abatement has to be undertaken. To ameliorate the pressure for more abatement, equation (17) implies that the trading ratio can be increased and so more emissions will be allowed. By the same logic, when the delivery coefficient is low and the abatement cost shock

also tends to be low (e.g., negative), equation (17) implies that a higher trading ratio will restrict the amount of emissions that are allowed. As illustrated in Figure 2, given the same change in pollution level, cost savings from extra pollution are higher than the increased cost from more abatement and so total abatement cost is reduced on average. Thus, setting a higher trading ratio pays off.

Compared to the case with a known delivery coefficient as given in equation (9), the optimal total permit number with an uncertain delivery coefficient, given by equation (25), have two additional covariance terms, which represent the covariance between e_2 and d ¹. The terms indicate that, if e_2 and d are positively correlated, then the optimal total permit number should be even higher and vice versa. Thus, with an uncertain delivery coefficient, there is an additional reason that the optimal total permit number might differ from the average pollution target.

Conclusions

There are important permit trading systems where the pollution target is given as an average value. In this paper, we have investigated the properties of such trading systems when the regulator does not have complete information on firms' abatement costs. It is well known that the regulator does not have to have any information on firms' abatement costs for a permit trading program to minimize the cost of achieving a fixed pollution target. However, we found that such information is useful in designing a trading program that meets an average target at

the lowest abatement costs. Given the great practicality of the established result that no cost information is required, our main purpose is not to advocate an alternative trading system. Rather, we intend to contribute to the literature by pointing out the implications when traditional permit trading system is used with an average pollution target.

In addition to the result that the optimal total permit cap is in general not equal to the average pollution target, we found that the optimal trading ratio is not equal to the delivery coefficient even if the regulator has complete information on the delivery coefficient. The latter result arises from the dual roles that the trading ratio plays in a permit trading program. First, the trading ratio determines the substitution rate among emissions of different sources. Second, and equally importantly, trading ratio affects the actual amount of pollution resulting from a trading program. This is because, when the trading ratio is not equal to the delivery coefficient, the total permit number is no longer the same as the total pollution level that will result from a trading program. When designing a program, the regulator can use the trading ratio to induce the desirable pollution level.

Acknowledgements

The authors express their special thanks to Catherine Kling for many interesting discussions. Rabotyagov acknowledges support from the US Environmental Protection Agency Science to Achieve Results Graduate Fellowship #91659501-0.

References

1. Baumol W., Oates W. *The Theory of Environmental Policy*, Cambridge University Press, Second edition, 1988.
2. Hoag D.L., Hughes-Popp J.S. Theory and Practice of Pollution Credit Trading in Water Quality Management, *Review of Agricultural Economics*, 19(2), 1997, pp. 252-262.
3. Horan, R.D. Differences in Social and Public Risk Perceptions and Conflicting Impacts on Point/Nonpoint Trading Ratios, *American Journal of Agricultural Economics*, 83(4), 2001, pp. 934-41.
4. Horan R.D., Shortle J.S. When Two Wrongs Make a Right: Second-Best Point Nonpoint Trading Ratios, *American Journal of Agricultural Economics*, 87(2), 2005, pp. 340-352.
5. Kling C.L., Rubin J. Bankable Permits for the Control of Environmental Pollution, *Journal of Public Economics*, 64, 1997, pp. 101-115.
6. Lewis T.R. Protecting the Environment when Costs and Benefits are Privately Known, *RAND Journal of Economics*, 27(4), 1996, pp. 819-847.
7. Malik A., Letson D., Crutchfield S. Point/Non-point Source Trading of Pollution Abatement: Choosing the Right Trading Ratio, *American Journal of Agricultural Economics*, 75 (4), 1993, pp. 959-967.
8. Montero J-P. Multipollutant markets, *RAND Journal of Economics*, 32 (4), 2001, pp. 762-774.
9. Montero J-P. Optimal Design of a Phase in Emissions Trading Program, *Journal of Public Economics*, 75, 2000 pp. 273-291.
10. Montgomery W.D. Markets in Licenses and Efficient Pollution Control Programs, *Journal of Economic Theory*, 5, 1972, pp. 395-418.
11. Segerson K. Uncertainty and Incentives for Nonpoint Pollution Control, *Journal of Environmental Economics and Management*, 15, 1988, pp. 87-98.

¹ Note that $Cov(d, e_2^*) = \frac{Cov(d, \theta_2) - t^* Cov(d, \theta_1)}{2c}$.

12. Economics of Pollution Trading for SO₂ and NOX, Annual Review of Environment and Resources, Vol. 30, pp. 253-289. (Volume publication date November 2005) First published online as a review in advance on July 25, 2005 Dallas Burtraw, David A. Evans, Alan Krupnick, Karen Palmer, and Russell Toth.
13. The Market-based Lead Phasedown Richard G. Newell and Kristian Rogers November 2003, Resources for the Future Discussion Paper 03-37.
14. U.S. Environmental Protection Agency (USEPA), Water quality trading assessment handbook, EPA-841-B-04-001, 2004.
15. National Ambient Air Quality Standards, 2007a. <http://www.epa.gov/air/criteria.html>.
16. Overview of current total maximum daily load (TMDL)-program and regulations. <http://www.epa.gov/owow/tmdl/overviewfs.html>. Accessed 2007h.
17. Fact Sheet-Proposed Reissuance of National Pollutant Discharge Elimination System (NPDES) Stormwater Multi-Sector General Permit for Industrial Activities, 2007b. http://www.epa.gov/npdes/pubs/msgp2006_factsheet-proposed.pdf.
18. Woodward R.T., Kaiser R.A., Wicks A.M. The Structure and Practice of Water-Quality Trading Markets, *Journal of the American Water Resources Association*, 38 (4), 2002, pp. 967-979.

Appendix

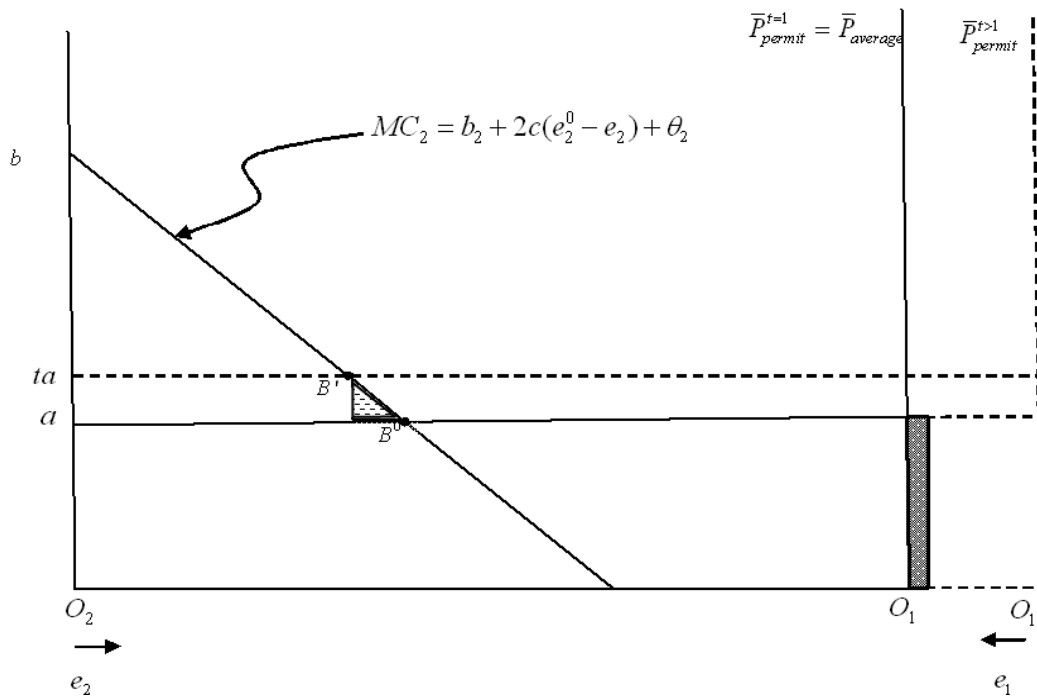
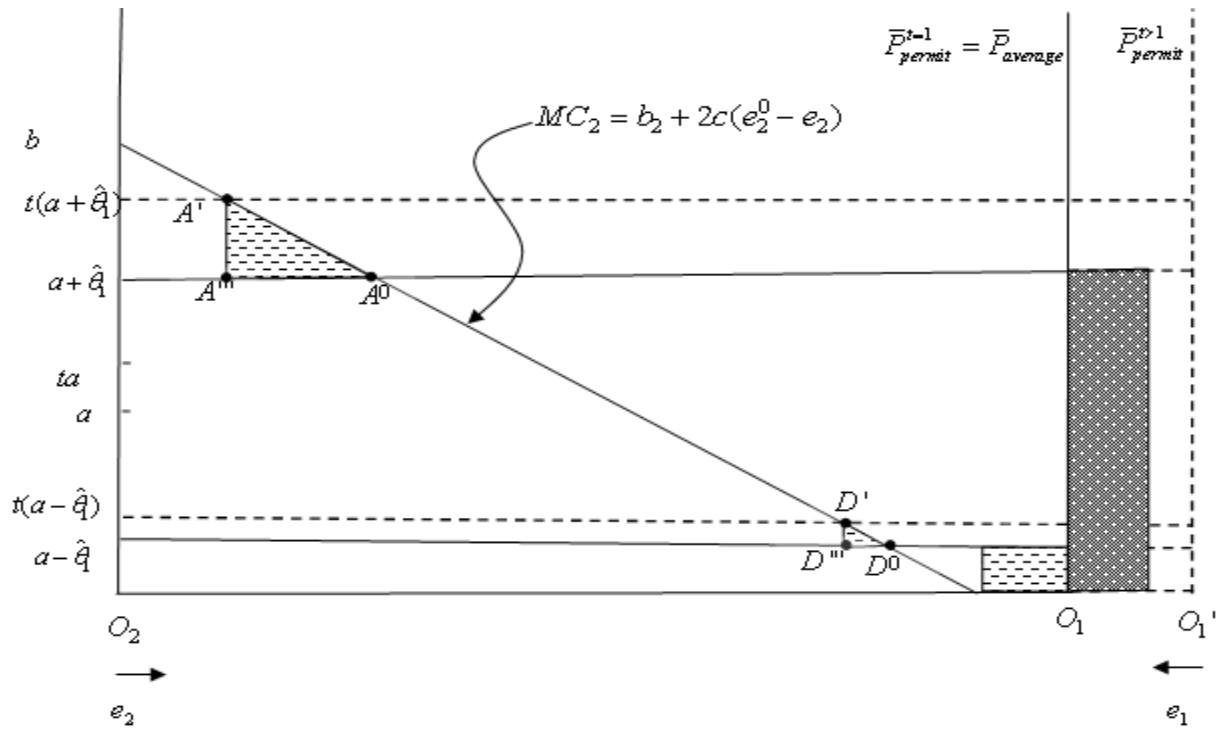

Fig. 1. The effects of setting $t^* > d = 1$ under the average pollution constraint $E[e_1 + de_2] = \bar{P}_{average}$ and the permit market constraint $e_1 + te_2 = \bar{P}_{permit}$ (for $\theta_1 = 0, \theta_2 < 0$)



Note: In the Figure, θ_1 is assumed to take two values, $+\hat{\theta}_1 > 0$, and $-\hat{\theta}_1$ with equal probability.

Fig. 2. A comparison of the welfare effects when θ_1 is high versus when θ_1 is low for a given value of θ_2 ($\theta_2 = 0$)