

Thin-walled shell foundations

*Yakov Pronozin*¹, *Tatyana Maltseva*^{2,3*}, *Oleg Poroshin*¹ and *Anna Medvedeva*¹

¹Industrial University of Tyumen, 38, Volodarskogo str., Tyumen, Russia, 625000

²Tyumen Branch of Khristianovich Institute of Theoretical and Applied Mechanics of SB RAS, 74, Taimirskay str., Tyumen, Russia, 625000

³Tyumen State University, 6, Volodarskogo str., Tyumen, Russia, 625003

Abstract. The article presents a study of the interaction of strip foundations of multistorey apartment houses united by flat cylindrical shells with a ground base. The foundation of a 17-storey residential building has been taken as an example. The ground base consists of strong upper and highly compressible underlying layers. The use of traditional foundations under the specified conditions is hardly possible. The calculation scheme of the building and the stages of the ground foundation work are represented. Also, the researchers share the results of geotechnical monitoring in the construction process including observations of settlements at 25 points with an accuracy of 0.1 mm and measurement of layer-by-layer deformations of the ground base under the building to a depth of 10 meters from the surface. The diagrams demonstrate the actual settlement of the building with increasing load and layer-by-layer deformations of the ground base in depth are presented.

1 Introduction

The construction of facilities in areas with soft clay and floury water-saturated soil is determined by the expansion of urban infrastructure, civil and industrial development of new territories. The study of the stress-strain state of soft bases, their bearing capacity, is topical [1, 2]. When increased load (exceeding the pressure of 250 kPa) is put on soft ground base, the design of foundations becomes a rather complicated engineering task. The use of driven piles can solve this problem provided that there is enough firm ground, usually sand, at a depth of up to 12 meters. However, firm ground can often be found at a depth of 15, 20 or more meters. In this case, there are areas where the upper layers of the ground base are composed of sufficiently firm clay and floury soils with a thickness of 2 to 6 and more meters. Under such conditions, traditional slab foundations cannot be used because of their excess settlement [3], and pile foundations are very expensive, since either composite driven piles or different types of drilled piers of great length and large diameter have to be used. A large number of ways to strengthen the foundation at projected heights have been developed and implemented [4, 5]. Some of them involve expensive materials and equipment.

In geotechnical engineering there is a tendency of using systems with controlled parameters [6-11]. One of the possible variants of the foundations for the specified conditions

* Corresponding author: maltv@utmn.ru

is the strip thin-walled shell foundation [12]. The peculiarity of such foundations is the controlled redistribution of reactive pressures under the shells and strips, which allows to reduce the depth of the compressible stratum up to 30% and thereby reduce the yield of the building [13-17].

The proposed foundation consists of elements differing in rigidity and mode of operation (Fig. 1). The first is a strip foundation with the width b_1 . It is a supporting structure for loadbearing walls or columns. The second is a thin-walled shell in the middle part (width b_2) binding the adjacent supporting strips in a mat footing. Its function is to transfer a certain (specified) part of the load from the structure onto the ground base in the middle part.

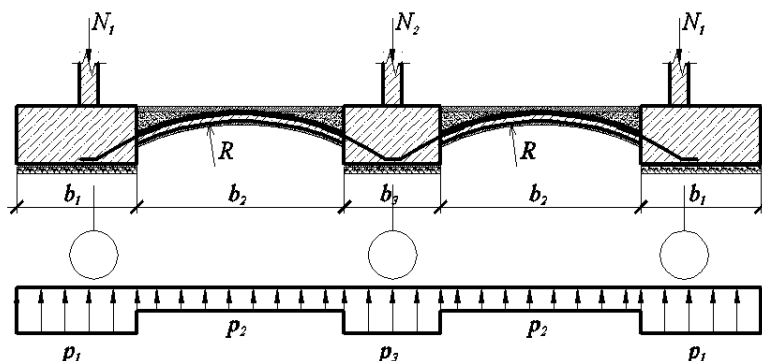

Fig. 1. Strip foundations with a flexible connection.

In the world practice of construction [18-20] such foundations have found wide application due to the following advantages.

The constructive advantages of the convex upward shell include work primarily on central stretching as the most energetically favorable kind of stress state, the possibility of forming a substantially uniformly stressed state along the length. Technological advantages include small thickness, single-layer reinforcement, low complexity of work performance. Economic advantages (compared to raft foundation) can be described as the use of a smaller amount of concrete and reinforcement and, as a result, a lower cost.

The aim of the research is to evaluate strip thin-walled shell foundation on a clay base under an average pressure exceeding 260 kPa and to estimate practical application of this constructive solution.

The following tasks were set and completed:

- there was designed and implemented the resource-saving strip thin-walled shell foundation with a controlled distribution of reactive pressure on the sole as in the case of the construction of a 17-storey residential building in the city of Tyumen;
- there were determined the optimal geometric parameters of the proposed foundation for the given ground and external loads;
- there were figured out the regularities of stress-strain state of clay soil at the base of the offered type of foundation.

2 Problem

To model the work of the considered foundation on the ground base, the model of a linearly deformable base is used. The Winkler hypothesis has been taken as a basis for the interaction of a one-span strip-shell foundation with a ground base.

Theoretical bases of calculation are stated in [22] (Fig. 2).

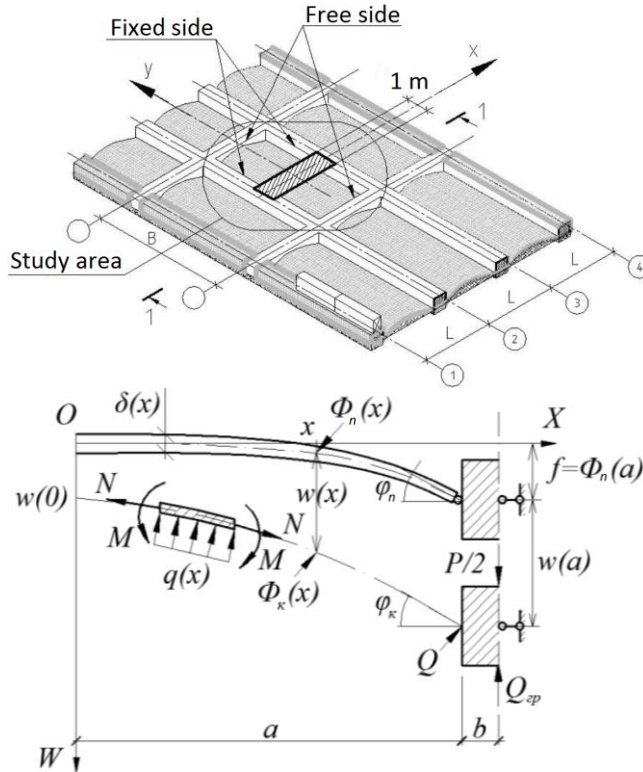

Fig. 2. Design scheme.

The differential equation for the interaction of the foundation with a linearly deformable base has the following form:

$$D \frac{d^4 w}{dx^4} + 2 \frac{dD}{dx} \frac{d^3 w}{dx^3} + \frac{d^2 D}{dx^2} \frac{d^2 w}{dx^2} - N \left(\frac{d^2 w}{dx^2} + \frac{d^2 \Phi_n}{dx^2} \right) + kw = 0, \quad (1)$$

Where:

- the first three summands denote the pressure on the ground, due to the flexural rigidity of the shell;
- the fourth term is the Laplace pressure, due to the tensile force in the shell enveloping the curved surface of the soil;
- the fifth term is the pressure caused by the reaction of the ground to the force action;
- $D(x)$ is the flexural rigidity;
- $k(x)$ is the coefficient of the bed under the shell;
- $w(x)$ is the settling of the soil;
- N is the axial extension of the shell.

Solving the equation, we find $w(x) \rightarrow \Phi k(x) = \Phi_n(x) + w(x)$, where Φ_n is the function of the initial median line of the shell (the curvature of the shell).

The boundary conditions are written taking into account the symmetry condition of the problem (the slope angle and the transverse force at the center of the shell are zero):

$$\left. \frac{dw}{dx} \right|_{x=0} = 0, \quad \left. \frac{d^3 w}{dx^3} \right|_{x=0} = 0; \quad (2)$$

the conditions of hinged junction of a shell with a strip foundation (the bending moment is zero) and the static equilibrium of all forces influencing the strip foundation:

$$D \frac{d^2 w}{dx^2} \Big|_{x=b_2/2} = 0 \quad P/2 - Q - N(b_2/2) \sin \alpha = 0. \quad (3)$$

Numerical calculation determines the settlement of the strip foundation and the shell, the reactive pressures below the base of the foundation, bending moments, longitudinal and transverse forces arising in the shell. As a result of the simulation, it was established [22] that it is necessary to take into account the longitudinal force in the shell when the foundation under consideration is interacting with the ground base, and the hinge is the most rational junction of the shell with the strip foundation. In this case, the foundation settlement decreases by 30%, the bending moments in the shell sections decrease by 80%, and there is no need to design a complex rigid junction of the shell with the strip foundation.

3 Methods

According to engineering and geological surveys, the microdistrict is to be built with 17-storeyed houses. On one of the sites firm soils lie to a depth of up to 9.5 meters, and below there are beddings of soft water-saturated silty-clay soils to a depth of more than 30 m (Table 1). In such conditions, the traditional options for constructing foundations were unacceptable.

Table 1. The values of physical and mechanical characteristics of the site soils.

| Description of the soil | Depth H, m | γI , $\kappa N/m^3$ | φII , deg. | $c II$, kPa | E, MPa |
|---|------------|-----------------------------|---------------------|--------------|--------|
| Loam heavy solid | 0-4.0 | 20.5 | 19.38 | 26.3 | 20.56 |
| The sand is fine average degree of saturation | 4.0-4.5 | 19.0 | 34.68 | 0.0 | 27.03 |
| Plastic sandy loam | 4.5-6.7 | 19.3 | 23.6 | 12.8 | 15.2 |
| The fine sand saturated with water | 6.7-9.5 | 19.3 | 33.99 | 0.0 | 33.32 |
| Loam ferruginized flowable plastic | 9.5-15.0 | 17.8 | 15.0 | 23.0 | 5.0 |
| Loam peschanny tight plastic | 15.0-30.0 | 17.7 | 14.67 | 34.0 | 7.58 |

Under the 17-storeyed residential house, a version of a mat footing of shallow foundation was developed. The footing consists of strip foundations joined by shallow shells. While analyzing the geotechnical situation, various versions of the foundation were modeled. The calculation was carried out in the SCAD program when the solid slab foundation settles to 35-40 cm, when the pile foundation exceeds the limit values. At the same time, the bearing capacity of 12-meter driven piles turned out to be very low because of small drag and friction over the surface at the bottom of the piles. A variant of the combined slab-pile foundation was also considered. However, it turned out to be ineffective and very expensive.

The structural scheme of an apartment house is a frame house, the material is reinforced concrete. The basement floor is made of solid monolithic walls. The average pressure from the building on the ground base is about 260 kPa. The design scheme of the building, including

the foundation and general view of the characteristic section of the foundation, is shown in Figure 3.

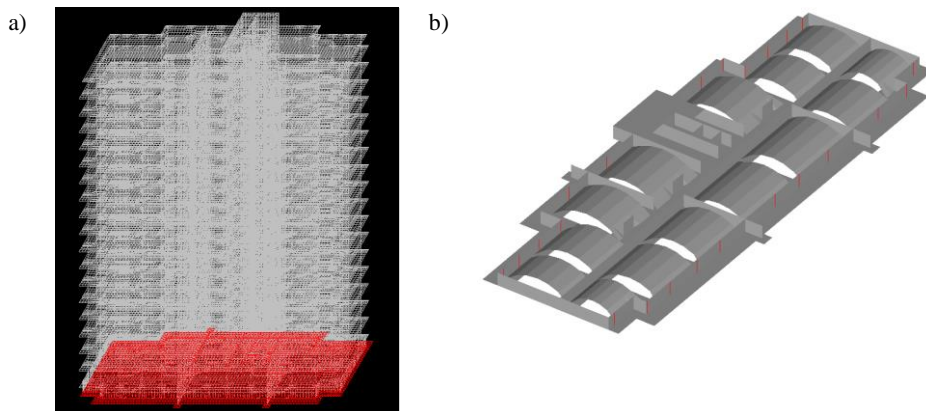

Fig. 3. The design scheme of the building: a) calculation scheme; b) general view of the foundation.

The control of the distribution of reactive pressures along the base of the foundation was achieved by such parameters as the width of the strip foundations, the span of the shell parts, shell depth, the curvature function of the shells, and their axial rigidity. With this kind of foundation, large reactive pressures occur under the strip foundations and the smaller ones under the shells. The design was carried out proceeding from the condition of quasilinear work of the base, i.e. not exceeding the average pressure of the design resistance of the soil R , both for the whole foundation as a whole, and for individual parts of the foundation. It should be noted that the loading of the base with the shells is a "load" for the ground base under the strip part and considerably, up to 2 times, increases its design resistance. In the calculations, the following system was modeled: "aboveground part - foundation - ground base", which allowed for considering the rigidity of the suprafundamental structure and its influence on the distribution of reactive pressures.

The process of modeling strip foundations joined with shallow shells demanded carrying out the following calculations: for the tensile forces in the shells, internal forces in the strips in vertical and horizontal directions (from the tensile force in the shells), calculation of the required eccentricity of loading from the basement walls onto the outer strip foundation to compensate for the twisting moment arising from the tensile forces in the shell. Besides, it became a necessary constructive measure to install several transverse strip bases (spacers) between the longitudinal strip foundations to reduce the bending moment in the horizontal direction.

The calculation was carried out in the SCAD program using a contact model based on the Winkler-Fuss hypothesis, in a spatial setting. All the main elements of the underground and aboveground parts of the building were taken into account.

Parameters accepted for calculation:

- Depth of the basement - 2,2 m;
- The size of the foundation and its cross-section are shown in Fig. 4;
- The average pressure from the construction on the ground base is 260 kPa.

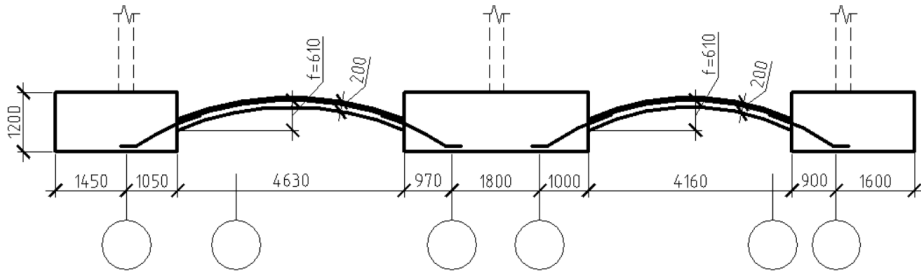

Fig. 4. The size of the foundation.

The stages of the foundation are shown in Fig. 5

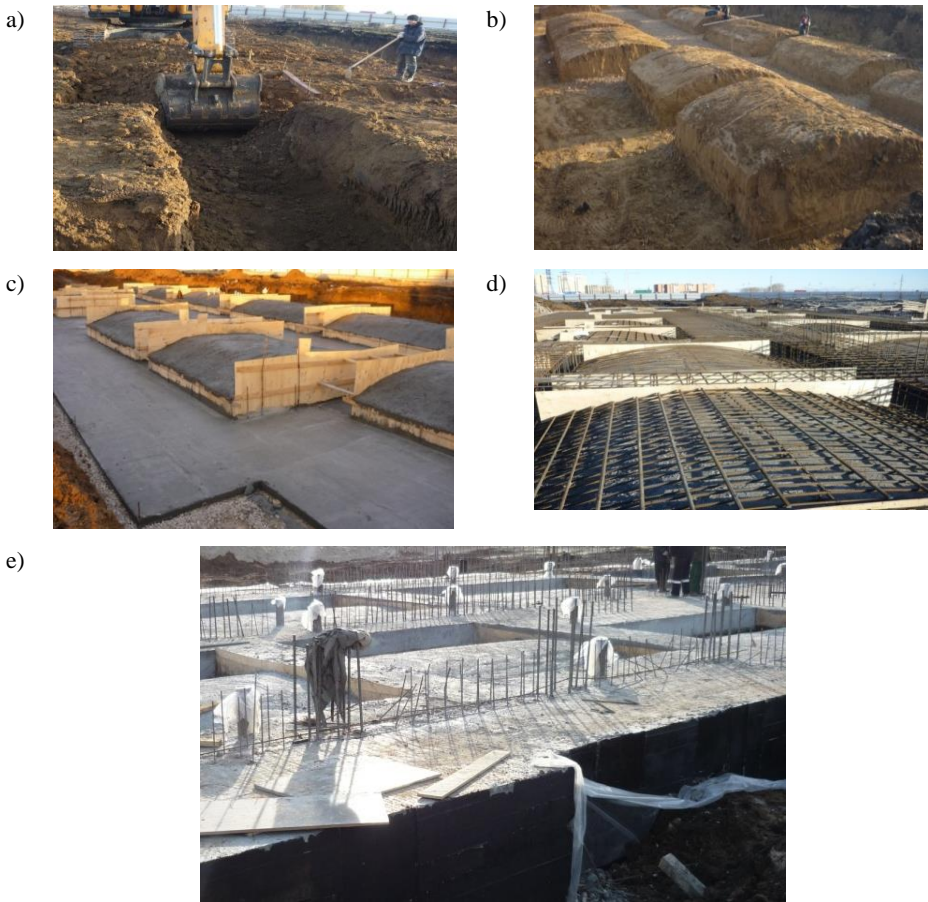

Fig. 5. Stages of the foundation: a) trenching for the strip foundations, b) formation of a curved surface for the shells, c) preparation of the site for the concreting, d) installation of reinforcing cages of strip foundations and nets of shells, e) concreting of the foundation.

After completion of the construction, the total load was about 260 kPa. Since the beginning of the construction, geotechnical monitoring has been carried out, including observation of settlement at 25 points with an accuracy of 0.1 mm and measuring layer-by-layer deformations of the ground base under the building to a depth of 10 meters from the surface.

4 Results and Discussion

Monitoring data: the graph of the actual settlement with increasing load is shown in Fig. 6. The maximum yield of the entire building at the last loading stage is 42 mm, the minimum is 36 mm. Using the technique presented in [21], the final settlement calculation was carried out. The value of the draft was 45 mm, which does not exceed the maximum permissible value.

Settling in time based on monitoring data is presented in Figure 7. In Fig. 8. depth of the foundation settlement is shown ($p = 260 \text{ kPa}$).

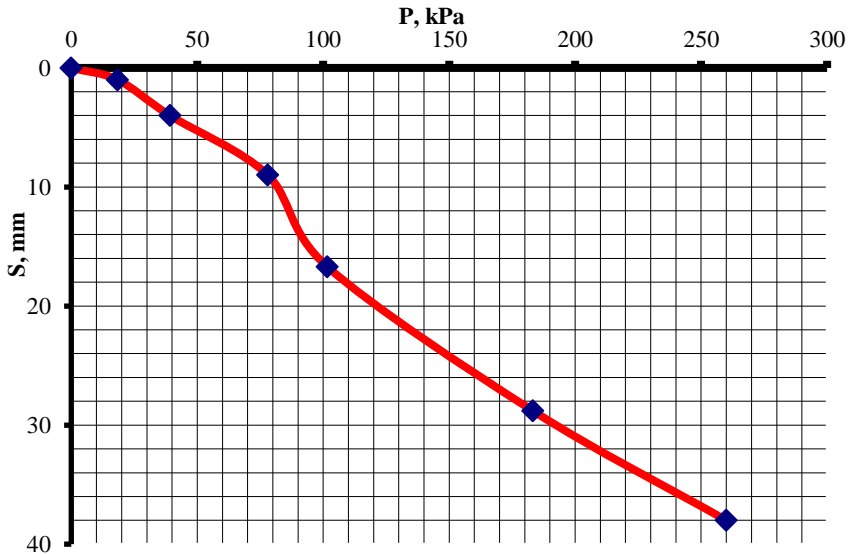

Fig. 6. Schedule pressure-draught.

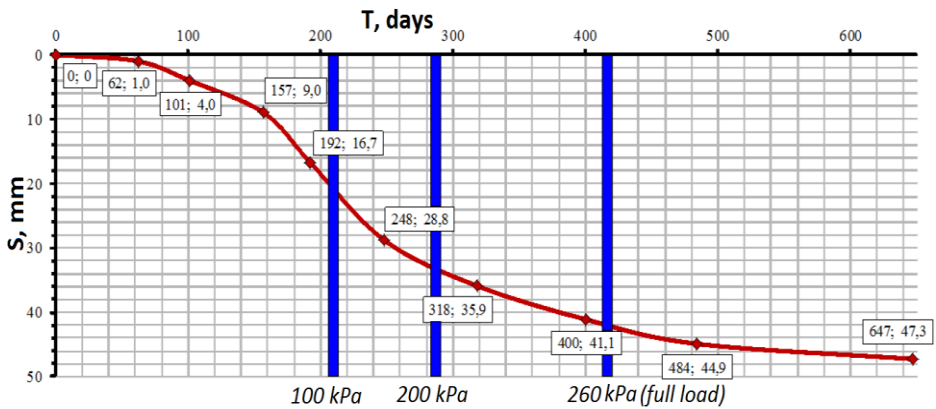

Fig. 7. Settling in time (monitoring data).

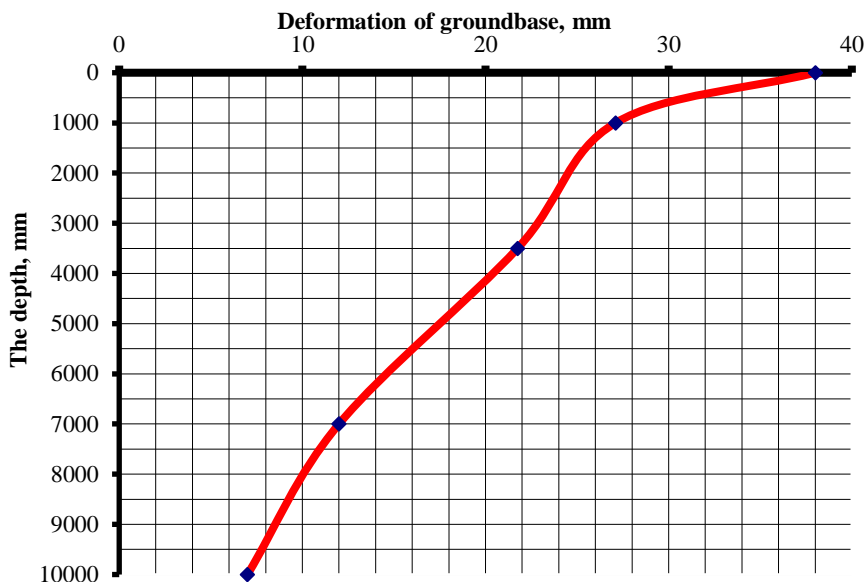

Fig. 8. Diagram of the deformation of the ground base at medium pressure $p = 260$ kPa.

At the location of deep points for measuring layer deformations of the ground base (Figure 8), maximum deformations of the ground are observed in the upper part of the base, in the zone of direct contact of the foundation with the soil, at a depth of 1 m (hard loam). At a depth of 1.0 to 3.0 m, deformation of the soil is very insignificant due to the occurrence of sand in this level ($E = 27$ MPa) and the dispersion of stresses with depth. The sand is underlain by a layer of water-saturated loam with $E = 5.0$ MPa, which leads to an increase in deformation, in spite of the considerable dispersion of stresses. About 5 mm of the building's yield is accumulated by deformation of very soft loam lying below 7.8 m. The maximum bending of the shell is 4 mm. The survey of the foundation did not reveal any power cracks in the shells working on strain. It is due to the frictional forces occurring at the "shell-ground" contact.

This paper confirms the results of other researchers in reducing the settlement of foundations with a curvilinear contact surface up to 25% [19]. For example, in [23], the researchers consider membrane foundations consisting of a power continuous flexible membrane of high-strength composite materials on the basis of fiber and a supporting contour in the form of a system of cross beams of the strip foundation. The author studied the ground base VAT and also received a reduction in the total settlement of the proposed type of foundation to 18% in relation to slab foundations with a double economic effect.

5 Conclusion

On the construction sites, composed of medium- and heavily deformable soils, traditional foundations are not always effective. Under certain conditions strip thin-walled shell foundations can be used. The justified use of effective types of shallow foundations allows reducing the main specified parameter - settlement - up to several tens of percent. Moreover, it increases the bearing capacity of the ground base while reducing the material consumption, namely steel and concrete - by 20-50% relative to traditional ones, for example, slab or pile-slab foundation. Calculation modeling data and experimental studies of a real object have shown the rationality of using a strip thin-walled shell foundation with a curved convex upward contact surface at loads exceeding 250 kPa. The increase in the rigidity of the ground

under the proposed foundation is caused by an additional lateral reduction of the ground due to the peculiarities of the shape of the contact surface. As monitoring results show with an accuracy of 10-15%, settlements correspond to the calculation data and within the design parameters. The economic effect of the use of strip thin-walled shell foundations in relation to pile-slab foundations reaches 45%.

References

1. R. Usmanov, I. Mrdak, N. Vatin, V. Murgul, *Applied Mechanics and Materials*, 633-634 (2014)
2. T. Maltseva, T. Saltanova, A. Chernykh, *Procedia Engineering* **165**, 839 (2016)
3. Russian Federation Standard SP 22.13330.2011
4. V. Korsun, N. Vatin, A. Franchi, A. Korsun, P. Crespi, S. Mashtaler, *Procedia Engineering* **117**, 970 (2015)
5. R.V. Melnikov, O.S. Poroshin, M.A. Samokhvalov, *Nauchnoye obozreniye* **17**, 73 (2015)
6. B.V. Goncharov, O.V. Galimurova, N.B. Gareeva, A.V. Bashlykov, *Soil Mechanics and Foundation Engineering* **48(2)**, 62 (2011)
7. Z.G. Ter-Martirosyan, Y.A. Pronozin, M.A. Stepanov, *Soil Mechanics and Foundation Engineering* **49**, 1 (2012)
8. O.S. Poroshin, M.A. Stepanov, *Uchebnoe posobie «Binarnye fundamenty-obolochki v geotekhnicheskoy stroitel'stve»* (Tyumen, 2018)
9. N. Kiselev, Y. Pronozin, M. Stepanov, L. Bartolomey, D. Keck, *MATEC Web of Conferences* **73**, 01017 (2016)
10. S.V. Ikonin, A.V. Sukhoterin, *Inzhenerno-stroitelnyy zhurnal* **3(55)**, 10 (2015)
11. D.V. Govorov, <http://conf.sfu-kras.ru/sites/mn2011/section231.html>
12. O.S. Poroshin, *Nauchno-prakticheskaya konferentsiya, Aktualnyye problemy arkhitektury, stroitelstva, energoeffektivnosti i ekologii* (Tyumen, 2016)
13. Z.G. Ter-Martirosyan, Y.A. Pronozin, L.R. Yepifantseva, O.S. Poroshin, *Sovremennyye problemy nauki i obrazovaniya* **2**, 209 (2015)
14. L. Epifantseva, O. Poroshin, Y. Pronozin, *10th International Conference on Geosynthetics, ICG* (2014)
15. F. Bakhtiari-Nejad, S. Milad Mousavi Bideleh, *Thin-Walled Structures* **53**, 26-39 (2012)
16. Y.A. Pronozin, R.V. Melnikov, O.S. Poroshin, *Vestnik grazhdanskikh inzhenerov* **4**, 78 (2010)
17. R. Rinaldi, M. Abdel-Rahman, A. Hanna, *International congress and exhibition, Sustainable civil infrastructures: Innovative infrastructure geotechnology* (Springer, Cham, 2017)
18. A.N. Bogomolov, A.N. Ushakov, *Soil Mechanics and Foundation Engineering* **50(2)**, 43 (2013)
19. R. Rinaldi, *Ph.D. thesis* (Concordia University, Montreal, 2012)
20. Standart organizatsii STO SROP 001-2015
21. A.V. Pilyagin (ChPI MGOU, Cheboksary, 2010)
22. Y.A. Pronozin, Thesis for the degree of doctor of technical Sciences, Tyumen (2016)
23. L.R. Epifantseva, PhD thesis (Tyumen, 2013)