

Journal of Engineering Science and Technology  
Vol. 13, No. 7 (2018) 2153 - 2165  
© School of Engineering, Taylor's University

## DESIGN OF HEAT EXCHANGER FOR EXHAUST HEAT RECOVERY OF A SINGLE CYLINDER COMPRESSION IGNITION ENGINE

R. RAJESH<sup>1,\*</sup>, P. SENTHILKUMAR<sup>2</sup>, K. MOHANRAJ<sup>3</sup>

<sup>1,2</sup>Department of Automobile Engineering, Madras Institute of Technology, Anna University, MIT Road, Radha Nagar, Chrompet, Chennai, Tamil Nadu 600044, India

<sup>3</sup>Department of Automobile Engineering, Rajalakshmi Engineering College, Rajalakshmi Nagar, Thandalam, Chennai-602105, Tamil Nadu, India

\*Corresponding Author: rajesh4mech@gmail.com

### Abstract

In automotive IC engines, only 25% of heat energy is utilized to produce power whereas about 75% of heat is wasted along with exhaust gas. This work attempts to recover the heat energy from engine exhaust gas with the aid of a heat exchanger. Initially, the amount of availability of heat energy in exhaust gas was identified by conducting heat balance test on a single cylinder naturally aspirated diesel engine at various loads. Based on the heat exchanger design principle, the number of fins, thickness, length and other dimensions are varied numerically and optimization has done to ensure maximum possible heat transfer from the exhaust gas. From the optimised heat exchanger, additional heat energy can be recovered from the exhaust gas and is beneficial for an engine to do useful work with an increment of overall efficiency.

Keywords: Engine exhaust gas, Heat exchanger, Heat energy recovery.

## 1. Introduction

Internal combustion engines are playing a vital role in power generation, automotive engineering, aeronautical field, agricultural as well in marines. The need of using diesel engine has been increased for ensuring comfortable living and fulfilment of basic needs of human being. Energy generation is a very important factor in the development of a country in economic aspects, technology and inventions. Moreover, equivalent or greater amount of fuel energy is wasted through exhaust systems compared to the actual useful fuel energy developed by the engine. According to the literature survey, the diesel engine only about 30% of available heat energy being used to produce useful power and remaining are losses by other means. About 40% heat energy is lost through the exhaust gas and about 30% of heat is lost through the engine cooling system.

It is being clearly observed that an enormous amount of heat energy is wasted in the exhaust. If a reasonable amount of heat energy is recovered from the exhaust gas means, it will lead to saving the fuel consumption and also it can do the considerable positive impacts on the emissions coming out from engines. The development of a waste heat recovery system will be the effective technique for improving the engine overall thermal efficiency and to recover the reasonable amount of waste heat.

The heat of exhaust gases can be recovered by employing a heat exchanger. Heat exchangers are used to doing an effective transfer of heat from one medium to another medium. It is widely used in refrigeration, power plants, chemical plants, a heating process in industries, etc. There are various types of the heat exchanger which are classified are based on their application. Out of all the types, to select the optimal heat transfer heat exchanger certain modifications should be done on heat exchanger surfaces [1]. Finned tube of the heat exchanger is best one to extract the heat for organic Rankine cycle [2]. By using the shell and tube of heat exchanger nearly 10-15% of heat extracted and the maximum possible amount of heat extraction is around 3.6 kW at full load condition [3, 4].

The mathematical modelling of a finned tube of the heat exchanger is clearly showing the effectively recovering of heat from R125a diesel engine [5]. The effectiveness was getting increased with the increase of engine power [6, 7]. The theoretical system developed to find out the performance of heat pipes and thermo-electric generator based on heat pipe in numbers, heat input and air flow rate [8, 9]. The benefits and thermo-economics of the waste heat recovery on a heavy-duty diesel engine and light duty petrol engine [10, 11]. The waste heat, energy recovery concept encouraged to do with the futuristic research activities due to the higher depletion rate and fossil fuels cost complications [12, 13]. The overall efficiency of the internal combustion engine is increased up to 9% by implementing the waste heat recovery concept by using a heat exchanger [14].

For the improvement of the exhaust heat recovery system, suggestions like high pressure and high effectiveness of heat exchanger design, increasing pressure ratio of the expander, using dynamometer and to ensure air tightness of the fittings have been strongly recommended by the researchers [15, 16]. The achievement of minimum pressure drop and optimized. The heat recovery is successfully done based on central composite design [17]. By increasing the radius of coils, the secondary flow effects due to centrifugal forces diminishes and flow of fluid

through the coils tends to flow in a straight path and as a result, the friction coefficient reduces consequently [18].

A new type of heat pipe air-gas heat exchanger has been proposed, designed and applied successfully with the feature of clean air passing through vertical tubes. Three-month continuous operation of recovering dirty exhaust gas waste heat shows that the new type heat pipe exchanger can save 15% natural gas in industry sector [19]. In the present work, perforated finned type of heat exchanger is designed and analysed with outer insulation to ensure the maximum heat extraction for organic Rankine cycle in a single cylinder 3.7 kW diesel engine. The thermal performance of the heat exchanger has been studied for various operating conditions of the engine.

## 2. Experimental Investigation

The proper selection of heat exchanger is the important factor in designing the waste heat recovery system. The experimental work mainly focussed to extract heat from the exhaust gas and to use it for organic Rankine cycle. This can be achieved by the properly optimized design of the heat exchanger and its analysis. Before designing the heat exchanger, available heat energy in the exhaust gas was identified by heat balance test. The detailed specifications and photographic view of an engine setup are shown in Table 1 and Fig. 1.

**Table 1. Engine specifications.**

Description	Type
<b>Name of the engine</b>	Kirloskar oil engine AV1
<b>Type of engine</b>	Vertical, 4S, high speed, CI engine
<b>No. of cylinders</b>	1
<b>IS rating at 1500 rpm</b>	3.7 kW
<b>Cubic capacity</b>	0.533
<b>Compression ratio</b>	16.5:1
<b>Injection pump &amp; type</b>	Single cylinder flange mounted
<b>Governor type</b>	Mechanical centrifugal type
<b>Method of cooling</b>	Water cooling



**Fig. 1. Single cylinder diesel engine.**

### 2.1. Identification of heat energy in the exhaust through heat balance

Part of the heat supplied to an I.C. engine through the fuel is utilized in doing useful work and the rest is wasted in overcoming friction, in exhaust gasses and engine cooling water. A statement of the supplied heat, useful work and heat wasted in overcoming friction, exhaust gasses, engine cooling is expressed as heat balance sheet. The heat balance thus gives a picture of the utility of heat supplied through the fuel.

Two important factors that influence the losses are the speed and output of an engine. The loss due to friction increases considerably more due to increases in engine speed than by an increase in load. Heat carried away by engine water increases slowly with load while heat carried away by exhaust gases increases abruptly beyond 80% of the rated power output due to higher combustion temperatures, inefficient combustion, etc.

The heat balance test has been conducted in a single cylinder diesel engine and the essential data is calculated by using below-mentioned standard equations and tabulated for different operating conditions.

$$\text{Brake Power (BP)} = 2\pi \times N \times T / (60 \times 1000) \quad \text{kW} \quad (1)$$

$$\text{Total Fuel Consumption (TFC)} = (10 \text{ cc}) / (\text{time taken}) \times 3600/1000 \\ \times 0.83 \text{ kg/hr} \quad (2)$$

$$\text{Total Heat Input (THI)} = (\text{TFC} \times \text{calorific value of diesel})/60 \quad \text{kJ/min} \quad (3)$$

$$\text{Useful work} = \text{BP} \times 60 \quad \text{kJ/min} \quad (4)$$

$$\text{Coolant losses} = m_w C_{pw} (t_3 - t_1) \quad \text{kJ/min} \quad (5)$$

$$\text{Fuel flow rate} = \text{TFC}/60 \quad \text{kg/min} \quad (6)$$

$$\text{Exhaust losses} = m_a C_{pa} (t_4 - t_2) \quad (7)$$

$$\text{Air flow} = \pi D^2/4 \times L \times N/2 \times \rho_a \quad \text{kg/min} \quad (8)$$

### 2.2. Theoretical design of heat exchanger parameters

The heat exchanger is an important element to recover the exhaust waste heat energy from an engine. The heat transfer rate, performance of heat exchanger can be decided by certain governing parameters. The parameters are overall heat transfer coefficient, total surface area, inlet and outlet fluid temperatures. In this present design, the counter flow type of heat exchanger was selected to transfer the heat from an engine exhaust to heat exchanging fluid. According to the heat balance experimental study of a diesel engine, it was finalized to design a perforated type heat exchanger with outer insulation for recovering the heat effectively. The heat exchanger design is carried out based on the concept of overall energy balance, which is mention in the following paragraphs. Figure 2 shows the overall energy balance in a heat exchanger to obtain the needed design of this research.

Heat is given by the hot fluid

$$Q = m_h C_{ph} (t_{h1} - t_{h2}) \quad (9)$$

where  $m$ - mass flow rate (kg/s),  $h$ & $c$ - refers hot and cold fluid,  $C_p$ - specific heat of fluid (J/kg °C), 1&2- refers to the inlet and outlet,  $t$ - Temperature of fluid (°C).

Assuming that there is no heat loss to the surroundings, potential and kinetic energy changes are negligible.

Heat absorbed up by the cold fluid

$$Q = m_c C_{pc} (t_{c2} - t_{c1}) \tag{10}$$

Total heat transfer can be calculated by using the equation:

$$Q = UA\theta_m \tag{11}$$

where  $Q$  is the total heat transfer (W),  $U$  is Overall heat transfer coefficient (W/m<sup>2</sup>K), and  $\theta_m$  is logarithmic mean temperature difference method (°C).

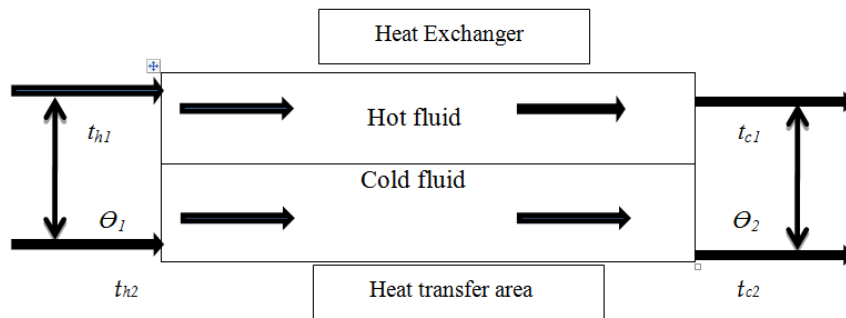

**Fig. 2. Overall energy balance in a heat exchanger.**

The design of the heat exchanger plays a critical role in the recovery of exhaust heat. The heat exchanger design can be performed using two different types of methods. They are

- Logarithmic mean temperature difference method (LMTD Method)
- Effectiveness- Number of transfer units method ( $\epsilon$ -NTU Method)

The logarithmic mean temperature difference method is easy to use in heat exchanger analysis when the inlet and outlet temperatures of the hot and cold fluids are known or can be determined from energy balance. LMTD method is very suitable for determining the size of a heat exchanger to realize the prescribed outlet temperatures when the mass flow rates and the inlet and outlet temperatures of hot and cold fluids are specified.

Another problem encountered in heat exchanger analysis is to determine the heat transfer rate and the outlet temperatures of hot cold fluids for prescribed fluid mass flow rates and inlet temperatures. The heat transfer surface area of the heat exchanger has been calculated, but the outlet temperatures are unknown.

The logarithmic mean temperature difference method could still be used for this alternative problem, but the procedure would require tedious iterations, and thus it is not practical. The effectiveness-I method greatly simplifies the heat exchanger analysis. The first law of thermodynamics stated that the rate of heat transfer from the hot fluid is equal to the rate of heat transfer to cold one.

In general

$$Q = mCp\Delta t \tag{12}$$

According to the first law of thermodynamics,

$$m_c C_{pc}(t_{c,out} - t_{c,in}) = m_h C_{ph}(t_{c,out} - t_{c,in}) \quad (13)$$

In addition, the effectiveness of the heat exchanger is known as the ratio between actual heat transfer rates to the maximum possible heat transfer rate. For the maximum possible heat transfer rate in a heat exchanger, it has been recognized that the maximum temperature difference is:

$$\Delta T_{max} = (t_{h,in} - t_{c,in}) \quad (14)$$

The maximum possible heat transfer in the heat exchanger is:

$$Q_{max} = C_{min} \times (t_{h,in} - t_{c,in}) \quad (15)$$

Once the effectiveness of the heat exchanger is known, the actual heat transfer rate can be determined from:

$$Q = \epsilon Q_{max} = \epsilon C_{min}(t_{h,in} - t_{c,in}) \quad (16)$$

The effectiveness also depends on the type of heat exchanger employed for the particular application. In our application, a simple double pipe heat exchanger with outer fins is chosen. The relation for effectiveness is given by:

$$\epsilon = \frac{1 - \exp\left(-\frac{U A_s}{C_{min}} \left(1 + \frac{C_{min}}{C_{max}}\right)\right)}{1 + \frac{C_{min}}{C_{max}}} \quad (17)$$

The overall heat transfer coefficient for the convection process gases to liquids obtained as from the reference value is 800 W/m<sup>2</sup>K.

The maximum limit for the length of the heat exchanger which can be employed in the exhaust system of the engine is  $L=0.8\text{m}$ . Thus, surface is available for heat transfer is,  $A_s = \pi DL = 0.175 \text{ m}^2$ .

$$C_{max} = m_h C_{ph} = 0.5 \quad \text{kW/K} \quad (18)$$

$$C_{min} = m_c C_{pc} = 1.6 \quad \text{kW/K} \quad (19)$$

The effectiveness of the heat exchanger is now calculated by applying the known values in the above Eq. (16).

$$\epsilon = \frac{1 - \exp\left(-\frac{U A_s}{C_{min}} \left(1 + \frac{C_{min}}{C_{max}}\right)\right)}{1 + \frac{C_{min}}{C_{max}}} = 0.689$$

As already mentioned, the maximum heat transfer rate is given by Eq. (15),

$$Q_{max} = C_{min}(t_{h,in} - t_{c,in}) = 4.24 \text{ (kJ/s)}$$

From Eq. (15)

$$Q = \epsilon Q_{max} = \epsilon C_{min}(t_{h,in} - t_{c,in}) = 0.689 \times (300 - 35) \times 1.6 = 2.92 \text{ (kJ/s)}$$

The outlet temperatures of the fluids can be determined since the heat transfer rate is known. The outlet temperature of the exhaust gases can be calculated from the equation,

$$Q = C_h(t_{h,in} - t_{h,out})$$

The calculated  $t_{h,out} = 150 \text{ }^\circ\text{C}$ . On the other hand, the outlet temperature of working fluid as it leaves the heat exchanger cannot be calculated directly as in the

case of exhaust gases, since phase change occurs in the working fluid. The relation is given by

$$Q = m_c C_{pc}(t_{c,boil} - t_{c,in}) + m_c h_{fg} + m_c C_{pc}(t_{c,out} - t_{c,in}) \cdot t_{c,out}$$

The outlet temperature of the cold fluid can be calculated from the above equation and the calculated value is  $T_{c,out} = 120\text{ }^\circ\text{C}$ .

Now, applying the values of inlet and outlet temperatures of the hot and cold fluids to find logarithmic mean temperature difference,

$$LMTD = \frac{\Delta t_2 - \Delta t_1}{\ln\left(\frac{\Delta t_2}{\Delta t_1}\right)} = 147\text{ }^\circ\text{C} \quad (20)$$

The area of the heat exchanger can be determined with the calculation of heat transfer rate, overall heat transfer coefficient and LMTD. From the area relationship equation, the length of the heat exchanger is calculated.

### 2.3. Modelling of perforated fin heat exchanger

Modelling of perforated fin type of heat exchanger is carried out by using calculated design values. The modelled diagram shows the hot and cold fluid flow directions and also expressing the fins construction in detail. Extended surfaces are mainly used for increasing the heat transfer rate to achieve maximum heat extraction and heat transfer rate. The modelling of the heat exchanger was carried out by using solid works software. Figures 3 and 4 show that the details of modelled schematic diagram of perforated fin heat exchanger and dimensions of the heat exchanger respectively.

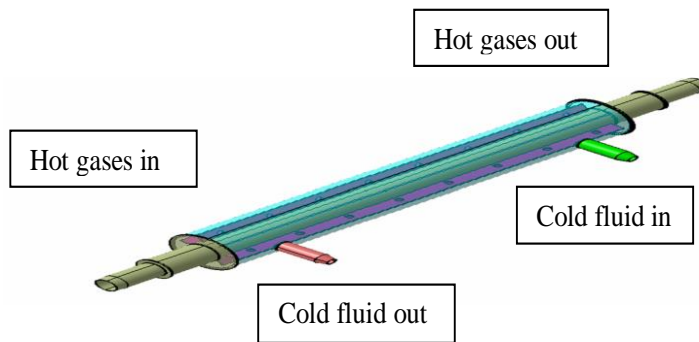

**Fig. 3. Schematic diagram of designed perforated fin heat exchanger.**

Heat exchanger material selected was copper due to its thermal properties. It is particularly considered with the thermal conductivity of 399 W/mK. All other properties of copper are enhancing the requirement of the heat exchanger for extracting maximum heat from the exhaust gas. The copper is also used as fin material in the heat exchanger. In order to identify the optimized function heat exchanger fins, the design carried out with a different set of thickness, height, and numbers.

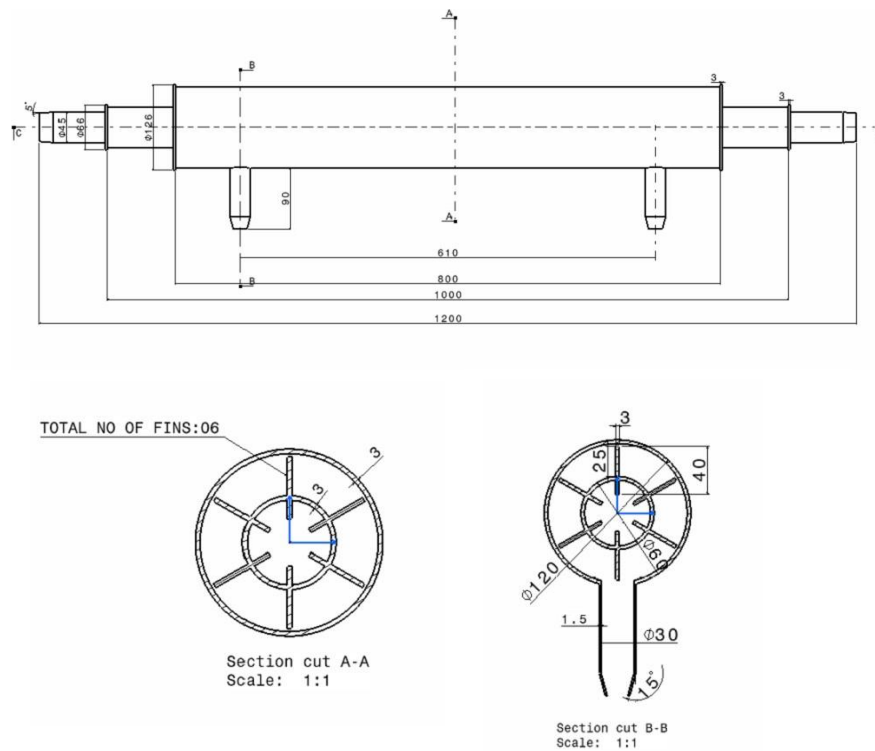

**Fig. 4. Dimensions of perforated fin heat exchanger.**

### 3. Results and Discussion

As described before, in order to recover the exhaust heat from the exhaust tailpipe before installing the heat exchanger certain baseline tests were conducted. The experimental results have been discussed in detail with suitable graphical diagrams.

#### 3.1. Heat balance test

In order to identify the available energy in the exhaust gas, a heat balance test has been conducted. The amount of heat utilised by the engine at various loads and constant speed are tabulated in Table 2. Figures 5(a), (b) and (c) show the amount of heat used to obtain useful work, the amount of heat losses in coolant and amount of heat losses in exhaust respectively.

Figure 5(a) depicts the useful work obtained by the engine at various engine load. From the plots, it was observed that the maximum amount of useful work obtained at 15 N-m of load and it decreases as the increment in the load on the engine. Figure 5(b) represents the coolant loss, which varies from 20% to 35% based on engine loading and operating conditions. It shows that the coolant loss reached a maximum of 35% when the brake power reaches 1kW and slowly it was reduced when the brake power is increased.



Figure 5(c) indicates the exhaust losses variation according to the engine operating condition. It is observed that the exhaust heat losses were more at part load operation and it's slowly getting reduced when it reaches the full load operation of an engine.

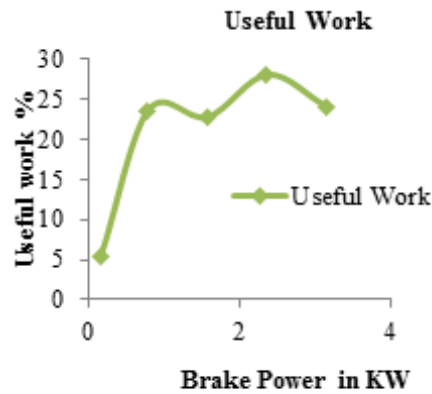

(a) Useful work variation with brake power.

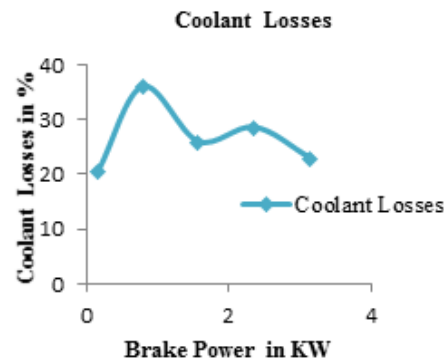

(b) Coolant losses variation with brake power.

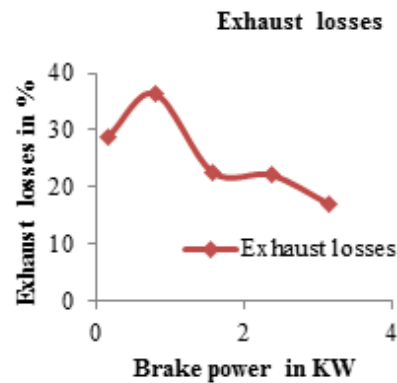

(c) Exhaust losses variation with brake power.

Fig. 5. Engine heat energy distribution results.

The heat balance sheet as shown in Table 2 clearly shows that the maximum amount of heat is wasted through the exhaust. Exhaust tailpipe is the best place to install the heat exchanger for recovering heat and to generate the power by using organic rankine cycle.

**Table 2. Heat utilization by the engine at various loads and constant speed.**

Engine speed (rpm)	Load torque (Nm)	Time taken in seconds	Brake power (kW)	Total fuel consumption (kg/min)	Total heat input (J/min)	Useful work (J/min)	Water inlet temp °C ( $t_1$ )	Water outlet temp °C ( $t_3$ )	Air inlet temp °C ( $t_2$ )	Exhaust temp °C ( $t_4$ )
1500	1	120	0.16	0.25	176	9.42	24	24	24	125
1500	5	106	0.79	0.28	200	47.1	24	24	24	168
1500	10	51	1.57	0.59	415	94.2	24	25	24	208
1500	15	42	2.36	0.71	504	141	24	25	24	241
1500	20	27	3.14	1.11	784	188	24	25	24	281

**In terms of percentage (%).**

Coolant losses (J/min)	Fuel flow rate (kg/min)	Exhaust flow rate (kg/min)	Exhaust losses (J/min)	Useful work	Coolant losses	Exhaust losses	Un-counted losses
35.9	0.004	0.50	51.0	5.3	20.3	28.9	45.4
71.7	0.005	0.50	72.7	23.6	35.9	36.4	4.1
107.6	0.010	0.51	93.9	22.7	25.9	22.6	28.8
143.4	0.012	0.51	111.2	28.0	28.5	22.1	21.4
179.3	0.018	0.52	133.4	24.0	22.9	17.0	36.1

### 3.2. Exhaust gas temperature

Exhaust gas temperature measurement was carried out in the different locations of the exhaust tailpipe. It clearly observed that from the Table 3 sufficient heat energy is available to install a heat exchanger at many locations. The cyclohexane was used as working fluid of heat exchanger for waste heat recovery system because of its low boiling point. It ensured that the heat conversion process is simple with the quick steam formation.

**Table 3. Exhaust gas temperature at different locations in tailpipe and 1500 rpm speed.**

Operating conditions	Distance from mouth(mm)				
	70	200	330	460	590
Exhaust gas temperature [°C]					
<b>Idling</b>	250	232	208	186	159
<b>Part-load</b>	308	278	242	206	183
<b>Full-load</b>	350	315	285	250	204

Figure 6 shows the graph on temperature gradients under different running conditions. It is visualized clearly that there is a gradual decrease in temperature from manifold mouth to the muffler. The graph shows a uniformity under all running conditions. It has been identified that temperature is high near the manifold mouth and it decreases when it nears muffler. Under loading conditions,

the temperature value increases compared to no-load conditions. It was observed that the exhaust gas temperature at no load condition nearer to the manifold mouth is 250 °C and 159 °C at the distance of 420mm from the manifold mouth. It has been understood that the possibility of exhaust heat recovery at idling and part load engine operation onwards.

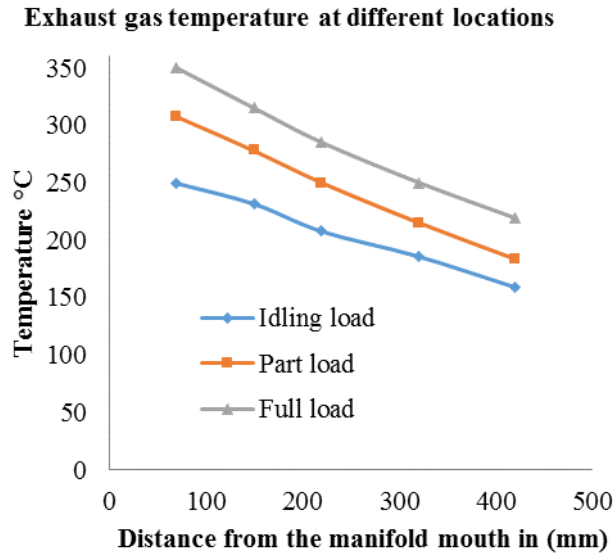

**Fig. 6. Temperature variation with manifold distance.**

#### 4. Conclusions

The present study was carried out to design and development of heat exchanger for single cylinder naturally aspirated diesel engine to recover the heat energy of exhaust gas.

The heat exchanger design was carried out based on the amount of heat availability in the exhaust gas, heat transfer area and the temperature difference between gas and fluid. The experimental result shows that about 40% of heat energy wasted in the diesel engine exhaust gas. The engine exhaust gas temperature was measured at different locations of the tailpipe and it elucidates that ample amount of heat is available in the exhaust gas.

The newly proposed technique has been recommended to extend the research on recovering waste heat energy from other heat sources. The recovered amount of waste heat from the exhaust gas can be used for many applications like generating electricity, refrigeration, cabin heating, etc.

**Nomenclatures**

$A$	Area, m <sup>2</sup>
$C_{pa}$	Specific heat capacity of air, kJ/kg
$C_{pw}$	Specific heat capacity of water, kJ/kg
$D$	Diameter, m
$N$	Speed, rpm
$Q$	Heat transfer rate, W
$Q_{max}$	Maximum heat transfer, W
$L$	Stroke length, m
$m_a$	Mass flow rate of air, kg/min
$m_w$	Mass flow rate of water, kg/min
$T$	Torque, N-m
$t$	Temperature, °C
$U$	Heat transfer coefficient, W/m <sup>2</sup> k

**Greek Symbols**

$\rho_a$	Density of air, kg/m <sup>3</sup>
$\epsilon$	Effectiveness
$\Delta t$	Temperature drop, °C

**Abbreviations**

BP	Brake Power
LMTD	Logarithmic Mean Temperature Difference Method
NTU	Number of Transfer Units

**References**

1. Hatami, M.; and Ganji. D.D. (2014). A review of different heat exchangers designs for increasing the diesel exhaust waste heat recovery. *Renewable and Sustainable Energy Reviews*, 37, 168-181.
2. Fu, J.; and Tang, Q.; Liu, J.; Feng, R. (2014). A combined air cycle used for IC engine supercharging based on waste heat recovery. *Energy Conversion and Management*, 87, 86-95.
3. Wang, E.; Zhang, H. Fan, B.; Ouyang, M.; Yang, K.; Fang, F.; Li, X.; and Wang, X. (2015). 3D numerical analysis of exhaust flow inside a fin-and-tube evaporator used in engine waste heat recovery. *Energy*, 82, 800-812.
4. Zhang, H.G.; Wang, E.; and Fan, B.Y. (2013). Heat transfer analysis of a finned- tube evaporator for engine exhaust heat recovery. *Energy Conversion and Management*, 65, 438-447.
5. Pandiyarajan, V.; Pandian, M.C., Malan, E.; and Seeniraj, R.V. (2011). Experimental investigation on heat recovery from diesel engine exhaust using finned shell and tube heat exchanger and thermal storage system. *Applied Energy*, 88(1), 77-87.
6. Bari, S.; and Hossain, S.N. (2013). Waste heat recovery from a diesel engine using shell and tube heat Exchanger. *Applied Thermal Engineering*, 61(2), 355-363.

7. Nwosu, P.N.; Nuutinen, M.; and Larmi, M. (2014). Thermal modelling of a novel thermosyphonic waste heat absorption system for internal combustion engines. *Energy*, 71, 21-31.
8. Remeli, M.; Tan, L.; Date, A.; Singh, B.; and Akbarzadeh, A. (2015). Simultaneous power generation and heat recovery using a heat pipe assisted thermoelectric generator system. *Energy Conversion and Management*, 91, 110-119.
9. Hatami, M.; Ganji, D.D.; and Gorgy-Bandpy, M. (2014). Numerical study of finned type heat exchangers for ICEs exhaust waste heat recovery. *Case Studies in Thermal Engineering*, 4, 53-64.
10. Wang, T.; Zhang, Y.; Zhang, J.; Peng, Z.; and Shu, G. (2014). Comparisons of system benefits and thermo-economics for exhaust energy recovery applied on a heavy-duty diesel engine and a light-duty vehicle gasoline engine. *Energy Conversion and Management*, 84, 97-107.
11. Baia, S.; Lu, H.; Wu, T.; Yin, X.; Shi, X.; and Chen, L. (2014). Numerical and experimental analysis for exhaust heat exchangers in automobile thermoelectric generators. *Case Studies in Thermal Engineering*, 4, 99-112.
12. Zhu, S.; Deng, K.; and Qu, S. (2014). Thermodynamic analysis of an in cylinder waste heat recovery system for internal combustion engines. *Energy*, 67, 548-556.
13. Bari, S.; and Hossain, S.N. (2015). Design and optimization of compact heat exchangers to be retrofitted into a vehicle for heat recovery from a diesel engine. *Procedia Engineering*, 105, 472-479
14. Mastrullo, R.; and Mauro, A.W.; Revellin, R.; and Viscito, L. (2015). Modelling and optimization of a shell and louvered fin mini-tubes heat exchanger in an ORC powered by an internal combustion engine. *Energy Conversion and Management*, 101, 697-712.
15. Lu, C.; Wang, S.; Chen, C.; and Li, Y. (2015). Effects of heat enhancement for exhaust heat exchanger on the performance of thermoelectric generator. *Applied Thermal Engineering*, 89, 270-279.
16. Shirvan, K.M.; Mirzakhani, S.; Kalogirau, S.A.; Oztop, H.F.; and Mamaurian, M. (2017). Heat transfer and sensitivity analysis in a double pipe heat exchanger filled with porous medium. *International Journal of Thermal Sciences*, 121, 124-137.
17. Hatami, M.; Jafaryar, M.; and Ganji, D.D.; and Gorji-Bandpy, M. (2014). Optimization of finned-tube heat exchangers for diesel exhaust waste heat recovery using CFD and CCD techniques. *International Communication in Heat and Mass Transfer*, 57, 254-263.
18. Seyyedvavilu, M.H.; and Ranjbar, S.F. (2015). The effect of geometrical parameters on heat transfer and hydro dynamical characteristics of helical exchanger. *International Journal of Recent Advances in Mechanical Engineering (IJMECH)*, 4(1), 35-46.
19. Tian, E.; He, Y.-L.; and Tao, W.-Q. (2017). Research on a new type waste heat recovery gravity heat pipe exchanger. *Applied Energy*, 188, 586-594.