



Strengthening airfield pavements with cement concrete layers

JAN MARSZAŁEK, KAROLINA GULAŃCZYK, PAWEŁ MUZOLF

Military University of Technology, Faculty of Civil Engineering and Geodesy,
2 Gen. W. Urbanowicza Str., 01-928 Warsaw, Poland, jan.marszalek@wat.edu.pl,
karolina.gulanczyk@wat.edu.pl, pawel.muzolf@wat.edu.pl

Abstract. The paper presents original solutions and methodology for determining the thickness of cement concrete strengthening layers for repairing and upgrading existing flexible and rigid airfield pavements. Flow diagrams and nomograms for determining edge stress were developed. These are novel solutions which have not been presented in a similar form before now. After deriving the above relations, a method for the practical utilisation of the resulting monograms depending on the parameters of existing airfield pavement and properties of the cement concrete strengthening layer is presented. Preparing calculation-based charts using the derived equations will markedly shorten the procedure of selecting the thickness of cement concrete strengthening layers for existing flexible airfield pavements that require repair depending on the degree of their wear.

Keywords: rigid airfield pavement, flexible airfield pavement, pavement strengthening

DOI: 10.5604/01.3001.0012.0972

1. Introduction

Currently, the construction of new airfields is a rarity in Poland, mainly due to economic factors. Particular importance has therefore been placed on the operation and maintenance of existing airfields.

On account of the gradual deterioration of existing airfield pavements, both concrete and bituminous, caused by them remaining in use for many years and by the emergence of aircraft of increasing weight, there is an ever greater need for repairs and upgrades of these pavements.

The issue addressed in this paper concerns the methods of strengthening existing airfield pavements, both flexible and rigid, and the methods of calculating the thickness of cement concrete strengthening layers for strengthening these pavements. The basis for determining the layer thickness will be the ascertained wear percentage of the pavement to be repaired.

2. Cement concrete strengthening layers on flexible pavements

2.1. Specification of the issue

The issue addressed in this section concerns the method of strengthening existing flexible airfield pavements using a cement concrete layer, and the method of calculating the thickness of the layer in question. The basis for determining the layer thickness will be the ascertained wear percentage of the pavement to be repaired.

In the method presented below, the strengthening of an existing flexible pavement using a cement concrete strengthening layer is calculated using the determination of a substitute modulus E_z of the entire existing pavement.

2.2. Pavement diagram

In order to determine the rigidity modulus E_s , one first needs to replace all structural layers of the flexible pavement, which have the layer thicknesses h_1, h_2, \dots, h_m and rigidity moduli: E_1, E_2, \dots, E_m , with a single substitute layer h_n . The method described above is shown in the following diagram.

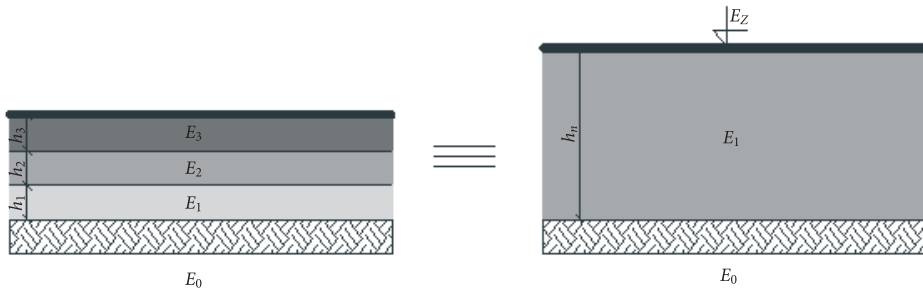

Fig. 1. Diagram of substituting individual flexible pavement layer thicknesses with the substitute pavement thickness h_n

2.2.1. Calculating the substitute modulus for the entire pavement

First, calculate the substitute pavement thickness h_n using the following equation:

$$h_n = h_2 \cdot \sqrt[2.5]{\frac{E_2}{E_1}} + h_3 \cdot \sqrt[2.5]{\frac{E_3}{E_1}} + h_m \cdot \sqrt[2.5]{\frac{E_m}{E_1}} + h_1 \quad (2.1)$$

where: h_1, h_2, \dots, h_m — thicknesses of individual pavement layers [cm],
 E_1, E_2, \dots, E_m — rigidity moduli of individual pavement layers [MPa].

Knowing the substitute pavement thickness h_n , calculate the substitute pavement rigidity modulus E_z , combining all layers of the existing pavement into a single modulus:

$$E_z = \frac{E_0}{1 - \frac{2}{\pi} \left(1 - \frac{1}{n^{3.5}} \right) \arctg\left(\frac{n \cdot h_n}{D}\right)} \quad (2.2)$$

where: E_0 — elastic modulus of the pavement [MPa],

$$n = \sqrt[2.5]{\frac{E_1}{E_0}},$$

D — diameter of the track of the gear leg wheel contact with the pavement [cm].

The pavement condition is specified using a damage coefficient, expressed as a percentage and described in detail in paper [4]. It is assumed that the coefficient z changes the total pavement deformation modulus according to the following equation:

$$E'_z = E_z \cdot z \quad (2.3)$$

where: z — degree of pavement wear [%].

A pavement diagram with pavement wear taken into account is presented in figure no. 2.

After calculating the substitute pavement thickness h_n and the substitute pavement rigidity modulus E_z , and knowing the percentage wear of the existing bituminous pavement, the existing flexible pavement is substituted with a Winkler pavement with the flexibility coefficient k_z , calculated according to the following formula:

$$k_z = \frac{E'_z}{D \cdot \omega \cdot (1 - \mu_{gr}^2)} \tag{2.4}$$

where: E'_z — substitute pavement rigidity modulus, including the degree of wear of existing flexible pavement [MPa],
 ω — mean settlement value for a circular surface,
 μ — Poisson coefficient for soil surface.

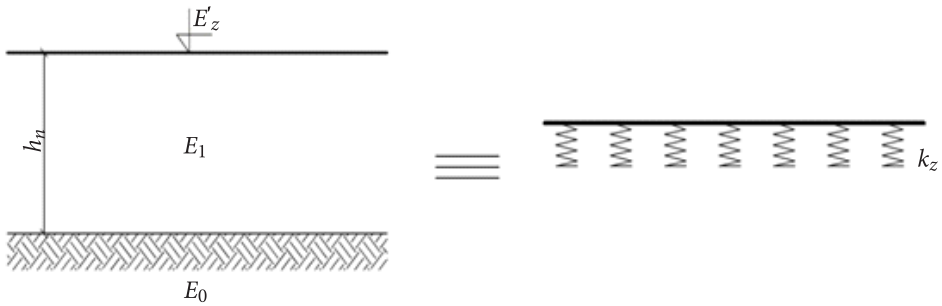

Fig. 2. Pavement diagram after taking into account the degree of wear of existing bituminous pavement

The thickness of the cement concrete strengthening layer on a worn flexible pavement is calculated using the Westergaard method for the highest occurring stress, which means edge stress. This method is described in detail in papers [1] and [2].

2.2.2. Preparation of the flow chart for calculating the thickness of rigid layers strengthening flexible pavements

Strengthening of existing flexible pavements using cement concrete layers is performed by substituting an existing flexible pavement with a Winkler pavement with a flexibility coefficient k_z [4] and [5]. This coefficient includes a percentage degree of wear of the existing flexible pavement. Strengthening layer thickness is calculated using the Westergaard method, described in detail in papers [1] and [2]. The flowchart for calculating cement concrete strengthening layer thickness, taking into account the previous analysis, is presented below in figure no. 3.

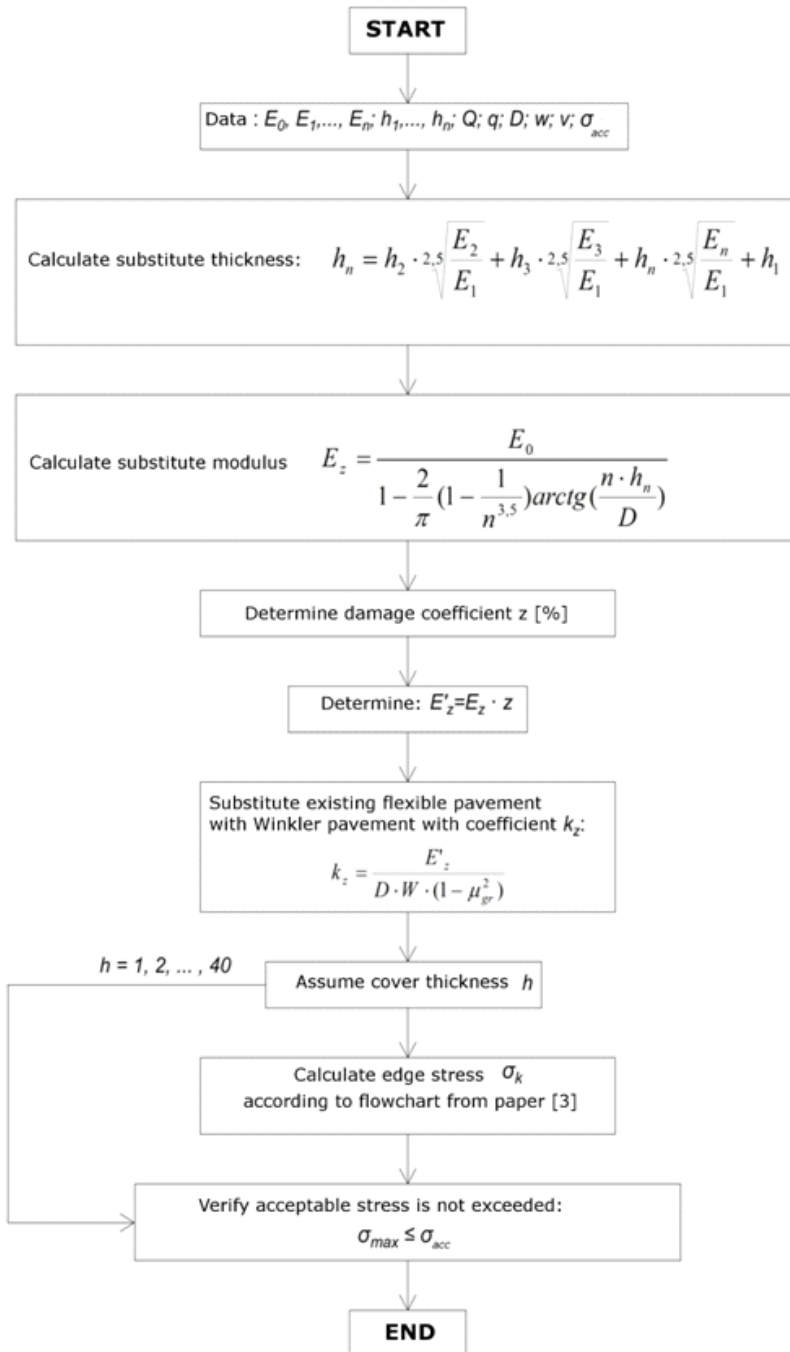

Fig. 3. Flowchart for selecting cement concrete strengthening layer thickness for repairing flexible airfield pavements

2.2.3. Sample nomogram determination for calculating cement concrete strengthening layer thickness on worn flexible pavements

Using the methodology presented in [2], [3], and [4] and in the flowchart (Fig. 3), a sample nomogram for specific parameters of pavement and aircraft was prepared.

Knowing the acceptable tensile stress during bending for the given concrete grade, and knowing the coefficient k_z determined for the existing pavement layers, the thickness of the required cement concrete strengthening layer h_n can be determined. Pavement structure data and cement concrete parameters are given in script [2] and paper [5].

The thickness of the cement concrete strengthening layer made of cement concrete C 35/45 was determined with edge stress for $\sigma_{acc} = 3.67$ MPa taken into account. The existing flexible surface, with 20% wear, was replaced with a Winkler pavement with coefficient $k_z = 694$ MPa/m.

The following values for the concrete slab and the aircraft were assumed:

- surface flexibility coefficient $k_z = 694$ MPa/m,
- concrete elasticity coefficient $E_b = 35000$ MPa,
- Poisson coefficient for concrete $\nu = 0.20$,
- 2-wheeled tandem main gear leg: $s_r = 152$ cm.

C-130 HERCULES transport airplane:

- takeoff weight $Q = 703$ kN,
- tyre pressure $q = 0.67$ MPa,
- subgrade: medium sand,
- $E_0 = 80$ MPa,
- single-layer pavement substitute modulus $E_z = 36$ MPa.

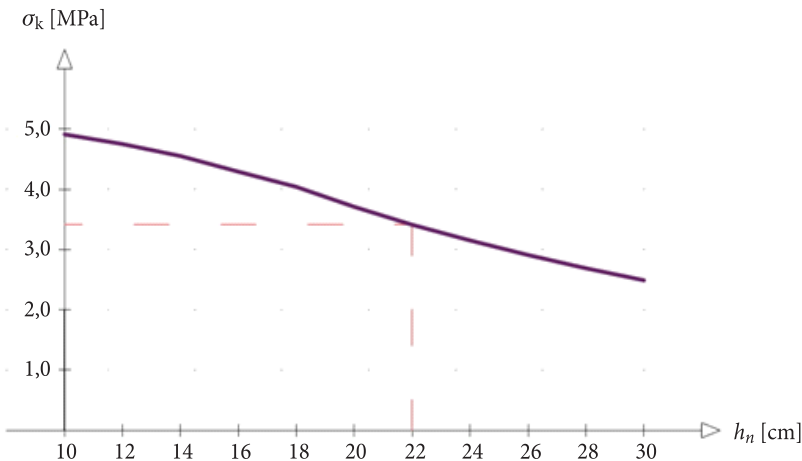

Fig. 4. Plot of edge stress relation to change of cement concrete strengthening layer thickness — h_n for a bituminous pavement with 20% wear

Based on the flowchart (Fig. 3), calculations were performed using the Excel software and an edge stress plot was prepared (Fig. 4) for the above data for a flexible pavement with 20% wear, depending on the cement concrete strengthening layer thickness.

Using the plot above and knowing the acceptable edge stress $\sigma_{acc} = 3.67$ MPa, the thickness of the required cement concrete strengthening layer can be read.

Example:

- at 20% pavement wear coefficient, a 22 cm cement concrete strengthening layer must be built to meet the acceptable stress condition.

3. Cement concrete strengthening layers on rigid pavements

3.1. Specification of the issue

The issue addressed in this section concerns the method of strengthening existing rigid airfield pavements using a cement concrete layer, and the method of calculating the thickness of the layer in question. The basis for determining the layer thickness will be the ascertained wear percentage of the pavement to be repaired.

In the method presented below, strengthening of an existing rigid pavement using a cement concrete strengthening layer is calculated in finite element method-based numerical software.

3.2. Calculation diagram

The starting point for the pavement under analysis will be its wear coefficient. The pavement wear coefficient is the most important parameter in assessing a pavement's technical condition. It has the greatest impact on flight safety and on keeping the pavement clean, which is highly important for modern jet and turbojet airplanes. The coefficient is calculated for selected damage, separately for concrete pavements and bituminous pavements. The details of calculating the pavement wear coefficient are discussed in paper [6] and quoted in paper [4].

By knowing the pavement wear coefficient it is possible to select a cement concrete strengthening layer suitable for the specific pavement properties.

Strengthening of an existing rigid pavement using a cement concrete strengthening layer is calculated in finite element method-based computer software.

A pavement structure diagram is shown in figure no. 5.

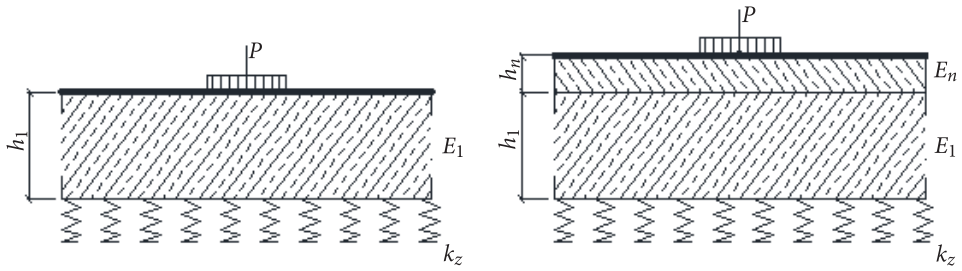

Fig. 5. Model diagram of the arrangement of pavement layers before and after a strengthening layer is applied

- h_1 — thickness of the existing concrete slab minus the percentage wear coefficient,
- E_1 — elastic modulus of the existing concrete slab,
- h_n — thickness of the planned cement concrete strengthening layer,
- E_n — elastic modulus of the cement concrete strengthening layer,
- k_z — elasticity coefficient of the subgrade, including foundation layers.

3.3. Nomogram for determining the layer thickness

The nomograms were prepared based on numerical calculations performed using Autodesk Simulation Mechanical software, which is based on the finite element method and used for computer aided design (CAD). The calculation diagram according to [7] and [8] and shown in figure no. 6 was adopted.

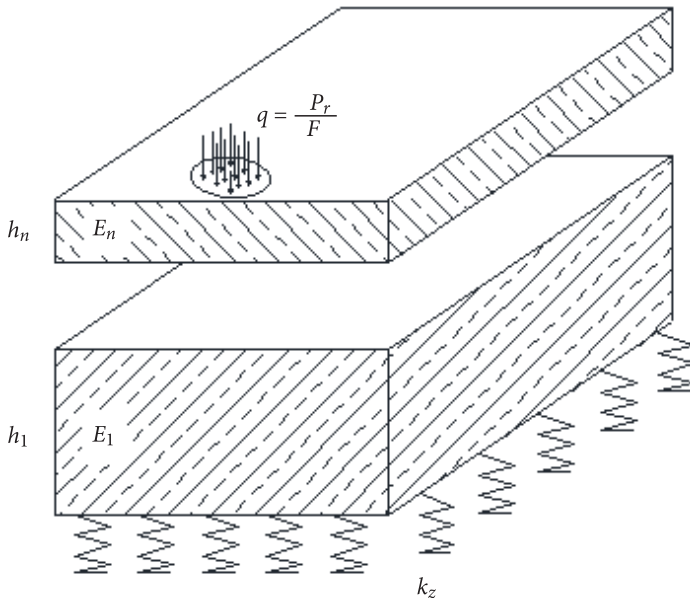

Fig. 6. Pavement layer arrangement calculation diagram used in the numerical software

Considering the methodology shown in the subsection above and using the Auto-desk Simulation Mechanical software, a sample nomogram for specific pavement and airplane data was derived.

By knowing the acceptable tensile stress during bending for the given grade of concrete used for the cement concrete strengthening layer and the existing concrete pavement (E_1 and E_n), the subgrade and foundation layer elasticity coefficient k_z and the percentage pavement wear coefficient, it is possible to calculate the thickness of the necessary strengthening layer.

In the example below, the pavement has a wear of 20%, and the concrete slab thickness after wear is $h_1 = 24$ cm.

The following values for the cement concrete strengthening layer and the aircraft are assumed:

- concrete elasticity coefficient of the existing pavement $E_b = 32000$ MPa,
- concrete elasticity coefficient of the planned strengthening layer $E_n = 35000$ MPa,
- elasticity coefficient of the subgrade, including foundation layers $k_z = 200 \div 500$ MPa/m.
- Poisson coefficient for concrete $\nu = 0.16$,
- acceptable edge stress reduced by a safety coefficient $\sigma_{acc} = 2.50$ MPa
- C-130 HERCULES transport airplane:
 - takeoff weight $Q = 703$ kN,
 - tyre pressure $q = 0.67$ MPa,
 - equivalent load per one gear leg $P_r = 195.6$ kN.

Based on the above data, the numerical software was used to model the existing worn concrete layer, laid on subgrade k_z , including the planned cement concrete strengthening layer. The obtained stress and bending results in a function of the modelled strengthening layer thickness are shown in the following nomograms.

Using the above plot and knowing the acceptable edge stress σ_{acc} and the subgrade elasticity coefficient, the thickness of the required cement concrete strengthening layer can be read.

Example:

— For a 20% pavement wear coefficient and a soil elasticity coefficient including foundation layers $k_z = 200$ MPa/m, a 9 cm cement concrete strengthening layer must be built to meet the acceptable stress condition. It bears stressing that due to technology issues, the minimum strengthening layer thickness should be 12 cm. However, considering a more adverse case, the numerical analysis was performed for a 10 cm thick layer with the minimum strength requirements met.

Furthermore, the authors intend to perform follow-up experimental testing to prove the thesis that it is possible build a polymer concrete strengthening layer for the purposes of repairing or upgrading existing airfield pavements. This material

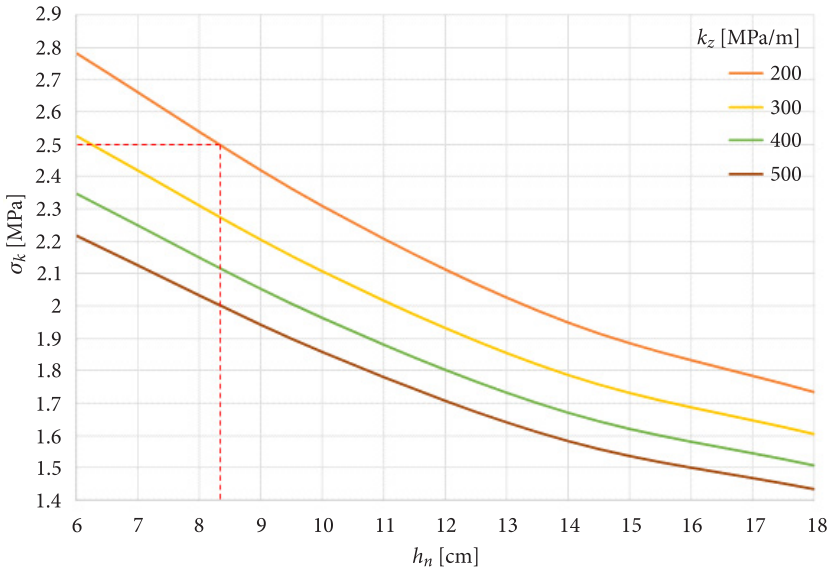

Fig. 7. Plot of edge stress relation to cement concrete strengthening layer thickness for a bituminous pavement worn by 20% for $k_z = 200 \div 500$ MPa/m

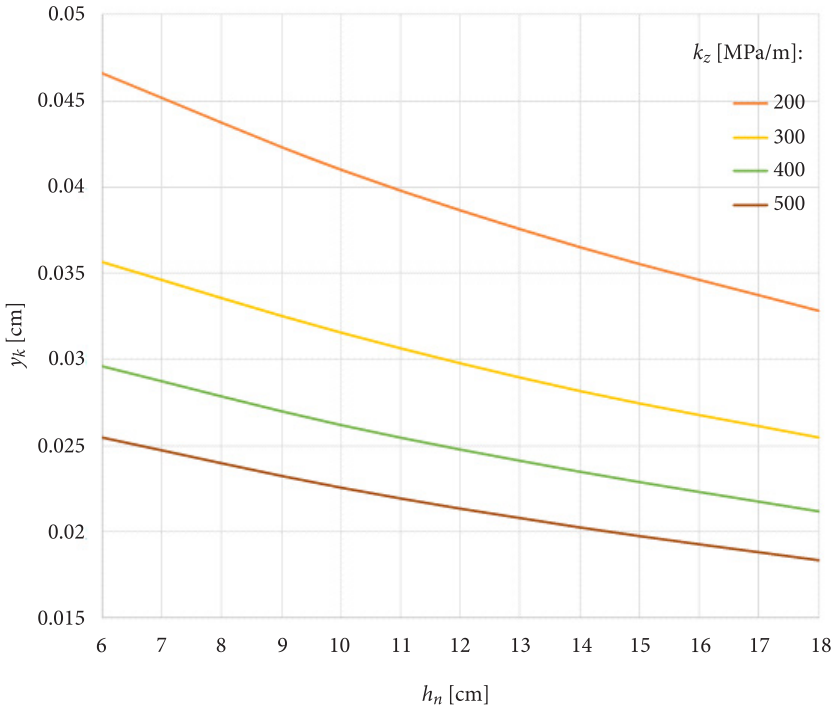

Fig. 8. Plot of edge bending relation to cement concrete strengthening layer thickness for a bituminous pavement worn by 20% for $k_z = 200 \div 500$ MPa/m

will enable the attainment of superior strength parameters compared to cement concrete while reducing the strengthening layer thickness at the same time.

Fig. 9 shows the results of the numerical calculations performed for one of the calculation variants — for a 10 cm thick strengthening layer on a 24 cm thick concrete slab and a soil elasticity coefficient including foundation layers $k_z = 200$ MPa/m. Fig. 9a shows the distribution of edge stress, while Fig. 9b shows the bending in a co-working concrete slab with a cement concrete strengthening layer.

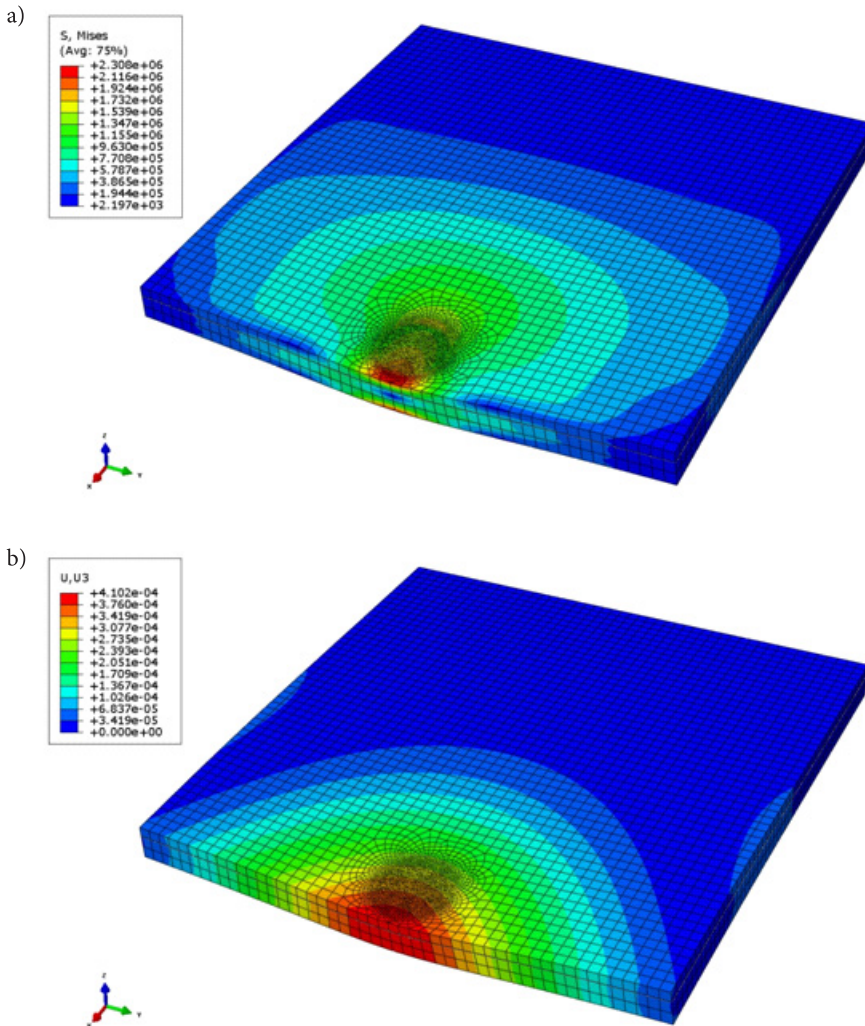

Fig. 9. Results of numerical calculations performed for the given calculation variant: a) distribution of reduced stress in the strengthening layer and concrete slab for a load by an aircraft gear leg on the edge of the structure; b) horizontal displacements of a cement concrete strengthening layer — concrete slab system

4. Summary and conclusions

The following were presented in this paper:

- methodology for calculating the thickness of cement concrete strengthening layers that are intended to strengthen existing rigid and flexible pavements as part of repairs or upgrades;
- a flowchart was prepared to enable the quick calculation of cement concrete strengthening layer thickness for flexible pavements using the Excel software;
- a method was developed for determining the thickness of cement concrete strengthening layers for rigid pavements using finite element method-based numerical software;

The solutions adopted take into account pavement wear when calculating the strengthening layers and are proposed by the authors who intend to verify this experimentally in the future.

The sub-programs and modelling methodology described will form the basis for preparing a comprehensive calculation software for cement concrete strengthening layers intended for repairing and upgrading existing airfield pavements.

This study was funded under the mission of the Military University of Technology.

Received January 26, 2018. Revised April 17, 2018.

REFERENCES

- [1] LEWINOWSKI Cz., *Wymiarowanie konstrukcji jezdni drogowych z betonu cementowego*, Państwowe Wydawnictwo Naukowe, Warszawa, 1982.
- [2] MARSZAŁEK J., *Budowa lotnisk, Część II. Obliczanie nawierzchni*, Wojskowa Akademia Techniczna, Warszawa, 1984.
- [3] MARSZAŁEK J., GULAŃCZYK K., *Zastosowanie metody Westergaarda do oceny oddziaływania samolotu Hercules C-130 na nawierzchnie lotniskowe*, Biuletyn WAT, vol. 64, no 3, 2015, 165-179.
- [4] MARSZAŁEK J., GULAŃCZYK K., *Wzmacnianie nawierzchni lotniskowych warstwami z mieszanek mineralno-asfaltowych*, Biuletyn WAT, vol. 65, no 3, 2016, 93-110.
- [5] GRACZYK M., *Dynamiczna metoda określenia nośności nawierzchni wielowarstwowych*. Praca doktorska Wojskowa Akademia Techniczna, Warszawa, 1994
- [6] MARSZAŁEK J., *Metoda analizy wyników badań parametrów użytkowo-eksploatacyjnych nawierzchni lotniskowych*. Praca doktorska, Wojskowa Akademia Techniczna, Warszawa, 1979.
- [7] GRACZYK M., ZBICIAK A., JÓZEFIAK K., *Projektowanie konstrukcji nawierzchni lotniskowych z wykorzystaniem metod analitycznych i MES*, Roads and Bridges — Drogi i Mosty, no 14, 2015, 101-115
- [8] GRACZYK M., KRASZEWSKI C., SZYMANKIEWICZ Cz., ZOFKA A., *Bezpieczeństwo użytkowania infrastruktury lotniskowej — Posadowienie nawierzchni lotniskowej na słabonośnym podłożu — minimalizacja osiadań, zwiększenie nośności*, Logistyka, no 4, 2015, 3462-3470

J. MARSZAŁEK, K. GULAŃCZYK, P. MUZOLF

Wzmacnianie nawierzchni lotniskowych warstwami z betonu cementowego

Streszczenie. W artykule przedstawiono oryginalne rozwiązania oraz metodykę postępowania przy wyznaczaniu grubości warstw wzmacniających z betonu cementowego dla remontów oraz modernizacji istniejących podatnych oraz sztywnych nawierzchni lotniskowych.

Opracowano schematy blokowe postępowania oraz nomogramy do wyznaczenia naprężenia krawędziowego. Są to nowe rozwiązania, które dotychczas w podobnej formie nie były przedstawiane. Po wyprowadzeniu wymienionych zależności zaprezentowano sposób praktycznego wykorzystania powstałych nomogramów w zależności od parametrów istniejącej podatnej nawierzchni lotniskowej oraz właściwości warstw wzmacniających z betonu cementowego.

Opracowanie wykresów na podstawie obliczeń za pomocą wyprowadzonych równań zdecydowanie przyspieszy procedurę doboru grubości warstw wzmacniających z betonu cementowego na istniejące podatne nawierzchnie lotniskowe, wymagające remontu w zależności od stopnia ich zużycia.

Słowa kluczowe: nawierzchnie lotniskowe sztywne, nawierzchnie lotniskowe podatne, wzmacnianie nawierzchni.

DOI: 10.5604/01.3001.0012.0972

