



Journal of AI and Data Mining
Vol 5, No 2, 2017, 327-335

Fractional Modeling and Analysis of Buck Converter in CCM Mode Peration

A. Moshar Movahhed¹, H. Toosian Shandiz^{2*} and S. K. Hosseini Sani³

1,2. Electrical and Robotic Engineering Faculty, Shahrood University of Technology, Shahrood, Iran.

3. Electrical Engineering Faculty, Engineering Faculty, Ferdowsi Mashhad University, Mashhad, Iran.

Received 14 November 2015; Revised 27 May 2016; Accepted 26 August 2016

*Corresponding author: htshandiz@shahroodut.ac.ir (H. Toosian Shandiz).

Abstract

In this paper, a fractional order averaged model is proposed for a DC/DC Buck converter in the continuous condition mode (CCM) of a wind turbine system. The DC/DC Buck converter is one of the main components, particularly in a stand-alone wind turbine system. Due to some practical restrictions, there were no input voltage and duty cycle of the converter, and therefore, the whole wind system was simulated by means of a computer, and the gathered data was used in the proposed method based on trial and error in order to find the fractional order of the converter. An obvious relationship was found between the controller performance and the mathematical model. A more accurate model leads us to a better controller, and this was confirmed by the simulation carried out in this work.

Keywords: *Fractional Calculus, Buck Converter, Averaged Circuit Model, Wind Turbine.*

1. Introduction

The global warming, growth of air pollution, and limited source of fossil energy have convinced the global society to use renewable sources of energy, in particular, wind energy in both the off-shore and on-shore types [1]. Variable-speed wind turbines with DFIG (Doubly-Fed Induction Generator) or full-power converter are used mostly with PMSG (Permanent Magnet Synchronous Generator) [2]. Of all types of systems, PMSG is usually implemented due to its simple structure and high reliability. [3]. Stand-alone wind turbine systems in rural and remote areas and also in lamp pillar can provide a sufficient and affordable electricity [3]. In stand-alone systems, battery absorbs the energy produced to ensure stability and get the most power from the wind.

Nowadays, the DC/DC power electronic converters play an important role in regulating the switching power supply and dc motor drives, and they are one of the most important charge control components in stand-alone wind turbines. Generally, the DC/DC power electronic converters input is unregulated voltage which rectified by a rectifier. Therefore, a control

scheme is necessary for adjusting the amplitude of output voltage and current into defined level [4]. Engineers generally consider integer order models for power electronic converters, while inductors and capacitors are fractional order in nature [5]. For instance, Wesrelund et al. have measured practically the fractional order of capacitors with different dielectrics at 1 kHz frequency and room temperature. They have found that the fractional order is 0.9776 for capacitors with polyvinylidene fluoride as dielectric or 0.99911 for capacitor with polysulfone as dielectric, and some other capacitors with different dielectrics have been measured [6]. On the other side, in [7], the researchers have proved that the inductor is fractional order in nature, and also Westerlund has measured practically the fractional order of an inductor with the air core coil equal to 0.97. In addition to the capacitors and inductors, fractional order modeling is more accurate than the integer order model in many real dynamical circuits [8]. The inductors and capacitors that exist in the market are in the fractional order of near to 1, and therefore, the integer order modeling of common electrical circuits is accurate enough, although the

fractional order models are capable of describing them better. Fractional modeling is essential when the inductors and capacitor used have an order far from 1 such as 0.5 and 0.1 [9], although these kinds of fractional order elements have not been produced in practice up to the present time.

It is necessary to state that all systems have fractional characteristics in nature but they are different in the amount of being fractional, and thus integer order models can describe the features of many systems that have less fractionalities [10]. This is the main reason why the available integer order models of many systems are capable to describing their properties well but, being more accurate, need fractional order analysis and model in all systems. It is preferable to use an integer order model instead of a fractional order model in some cases, whose amounts of fractionality are very close to integer numbers due to complexity and difficulty.

In this research work, fractional modeling and analysis is carried out for the DC/DC Buck converter used in a 1 KW wind turbine. The converter input is connected to the output of a universal bridge rectifier, and the converter output is connected to a battery bank and a constant dc load. The control scheme is necessary to have a high quality charging performance and capturing the most energy from the wind, and thus, for this purpose, an accurate mathematical model of the DC/DC Buck converter is essential.

2. Fractional calculus

Engineering students consider a derivative operator such as the one bellow:

$$\frac{dx}{dt}, \frac{d^2x}{dt^2}, \dots, \frac{d^n x}{dt^n} \quad \exists n \in N \tag{1}$$

But is there a necessity to use an integer number n? Is it possible to use rational, irrational or even complex numbers instead of n?

The concept of fractional calculus belongs to corresponding Marquis de L’Hopital to Gottfried Wilhelm Leibniz in 1695, and at that time, Leibniz replied this to L’Hopital “This is an apparent paradox from which, one day useful consequences would be drawn” [11].

Perhaps in a near future, conventional calculus is replaced by fractional calculus due to its ability to expand usual controllers in order to achieve a better performance [12]. Over the last few years, the application of fractional control has spread out due to its robust performance [13].

Although “fractional-order” is not a proper word, and “non-integer-order” is more accurate, “fractional-order” is generally used in the papers and literature [11].

There exist some definitions, as follow:

The Rieman-Liouville fractional-order integral is defined in (2).

$$I_c^\alpha F(t) = \frac{1}{\Gamma(\alpha)} \int_c^t (t-\tau)^{\alpha-1} f(\tau) d\tau \quad t > c, \alpha \in R^+ \tag{2}$$

where, $\Gamma(\cdot)$ is the Gamma function.

Equation (3) shows the Gamma function [15].

$$\Gamma(n) = \int_0^\infty e^{-u} u^{n-1} du \tag{3}$$

Note that substituting α by R^- in order to reach a fractional-order differential operator is not allowable in (2).

The Rieman-Liouville definition for the fractional-order derivative of order $\alpha \in R^+$ is indicated in (4) and (5).

$${}_R D^\alpha f(t) = D^m I^{m-\alpha} f(t) \tag{4}$$

Therefore,

$${}_R D^\alpha f(t) = \frac{d^m}{dt^m} \left[\frac{1}{\Gamma(m-\alpha)} \int_0^t \frac{f(\tau)}{(t-\tau)^{\alpha-m-1}} d\tau \right] \tag{5}$$

where, $m - 1 < \alpha < m, m \in N$.

Equations (6) and (7) show the Caputo derivative definition.

$${}_c D^\alpha f(t) = I^{m-\alpha} D^m f(t) \tag{6}$$

Therefore,

$${}_c D^\alpha f(t) = \frac{1}{\Gamma(m-\alpha)} \int_0^t \frac{f^{(m)}(\tau)}{(t-\tau)^{\alpha-m-1}} d\tau \tag{7}$$

where, $m - 1 < \alpha < m, m \in N$.

Laplace transform is the next operator used in this paper. It is shown for the Caputo fractional-order derivative in (8).

$$\ell[{}_c D^\alpha f(t)] = s^\alpha F(s) - \sum_{k=0}^{m-1} s^{\alpha-k-1} f^{(k)}(0) \tag{8}$$

3. State space model

Figure 1 shows the main scheme for a DC/DC Buck converter, which is controlled by the PWM (Pulse Width Modulation) unit.

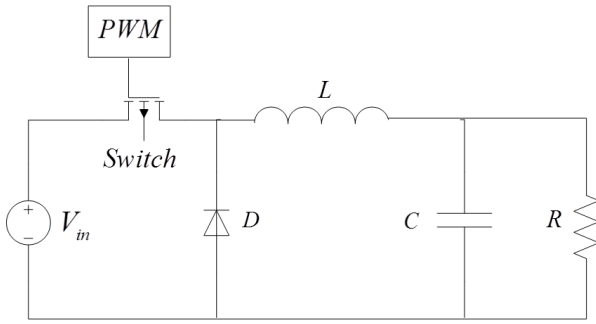

Figure 1. DC/DC Buck converter.

Perturbation of an inductor current in the continuous condition operation mode during a period of time can easily be seen in figure 2.

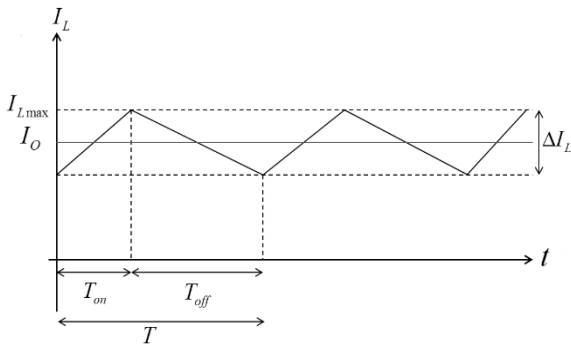

Figure 2. Perturbation of inductor current.

The relationship between the voltage and current of an inductor is expressed in (9) [6].

$$V_L(t) = L \frac{d^\alpha I_L(t)}{dt^\alpha} \quad (9)$$

in which, α indicates the fractional order of the inductor.

Also the relationship between the voltage and current of a capacitor is expressed in (10) [9].

$$I_C(t) = C \frac{d^\beta V_C(t)}{dt^\beta} \quad (10)$$

in which, β indicates the fractional order of the capacitor.

The capacitor voltage and inductor current are considered as the state space parameters, and the input voltage is allocated to the input vector.

$$X = \begin{bmatrix} i_L(t) \\ v_C(t) \end{bmatrix}, \quad U = [V_{in}(t)] \quad (11)$$

Using the following steps, the averaged model can be established. Two modes are considered for a DC/DC Buck converter, the switch-on and switch-off modes.

3.1. Switch-on mode:

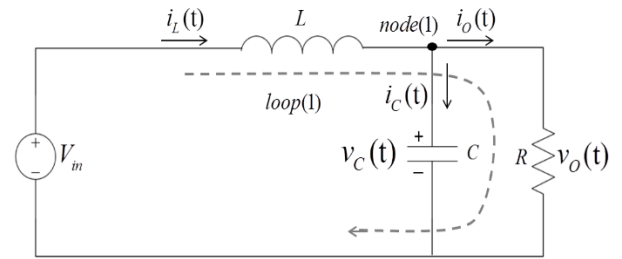

Figure 3. Switch-on mode circuit.

Using the voltage rule in figure 3, the following equation is achieved:

$$L \frac{d^\alpha i_L(t)}{dt^\alpha} = v_{in}(t) - v_o(t) \quad (12)$$

$$\rightarrow \frac{d^\alpha i_L(t)}{dt^\alpha} = \frac{v_{in}(t)}{L} - \frac{v_o(t)}{L}$$

The current rule was imposed, and (13) was reached.

$$C \frac{d^\beta v_C(t)}{dt^\beta} = i_L(t) - \frac{v_C(t)}{R} \quad (13)$$

$$\rightarrow \frac{d^\beta v_C(t)}{dt^\beta} = \frac{i_L(t)}{C} - \frac{v_C(t)}{RC}$$

The state space model can be written as follows:

$$\begin{bmatrix} \frac{d^\alpha i_L(t)}{dt^\alpha} \\ \frac{d^\beta v_C(t)}{dt^\beta} \end{bmatrix} = \begin{bmatrix} 0 & -\frac{1}{L} \\ \frac{1}{C} & -\frac{1}{RC} \end{bmatrix} \begin{bmatrix} i_L(t) \\ v_C(t) \end{bmatrix} + \begin{bmatrix} \frac{1}{L} \\ 0 \end{bmatrix} v_{in}(t) \quad (14)$$

$$[v_o(t)] = [0 \quad 1] \begin{bmatrix} i_L(t) \\ v_C(t) \end{bmatrix}$$

Therefore,

$$A_1 = \begin{bmatrix} 0 & -\frac{1}{L} \\ \frac{1}{C} & -\frac{1}{RC} \end{bmatrix}, B_1 = \begin{bmatrix} \frac{1}{L} \\ 0 \end{bmatrix}, C_1 = [0 \quad 1], D_1 = 0 \quad (15)$$

3.2. Switch-off mode:

The same approach is followed in this mode.

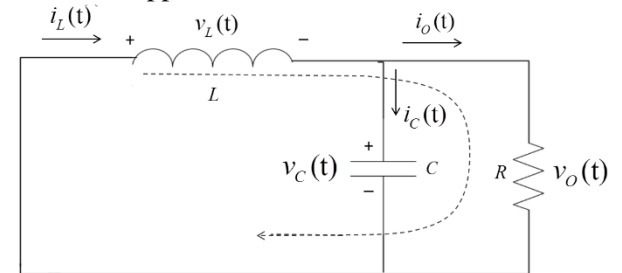

Figure 4. Switch-off mode circuit.

Voltage rule:

$$v_c(t) = -L \frac{d^\alpha i_L(t)}{dt^\alpha} \rightarrow \frac{d^\alpha i_L(t)}{dt^\alpha} = -\frac{v_c(t)}{L} \quad (16)$$

Current rule:

$$i_c(t) = i_L(t) - i_o(t) \rightarrow \frac{d^\beta v_c(t)}{dt^\beta} = \frac{i_L(t)}{C} - \frac{v_c(t)}{R} \quad (17)$$

Using (16) and (17), the state space model of the DC/DC Buck converter is obtained.

$$\begin{bmatrix} \frac{d^\alpha i_L(t)}{dt^\alpha} \\ \frac{d^\beta v_c(t)}{dt^\beta} \end{bmatrix} = \begin{bmatrix} 0 & -\frac{1}{L} \\ \frac{1}{C} & -\frac{1}{RC} \end{bmatrix} \begin{bmatrix} i_L(t) \\ v_c(t) \end{bmatrix} + \begin{bmatrix} 0 \\ 0 \end{bmatrix} v_{in} \quad (18)$$

$$[v_o(t)] = [0 \quad 1] \begin{bmatrix} i_L(t) \\ v_c(t) \end{bmatrix} + [0] v_{in}$$

Thus:

$$A_2 = \begin{bmatrix} 0 & -\frac{1}{L} \\ \frac{1}{C} & -\frac{1}{RC} \end{bmatrix}, B_2 = \begin{bmatrix} 0 \\ 0 \end{bmatrix}, C_2 = [0 \quad 1], D_2 = 0 \quad (19)$$

In comparison with the integer order state space model, the fractional state space model of DC/DC Buck converter has additional parameters (α, β) that indicate the fractional order of the inductor and capacitor, respectively. Although the fractional order model leads to more complexity in analysis, it can generate a more accurate model of systems.

4. Averaged state space model of fractional order buck converter

According to the averaging formula, it is possible to substitute the averaged value of each parameter in the state space model of DC/DC Buck converter.

$$\langle x(t) \rangle_T = \frac{1}{T} \int_t^{t+T} x(\tau) d\tau \quad (20)$$

x is an arbitrary variable of the Buck converter. By averaging a circuit variable over a period of switching, all the high-frequency switching harmonics will be removed [8]. Equation (21) can be proved [8].

$$\frac{d^\alpha \langle x(t) \rangle_T}{dt^\alpha} = \left\langle \frac{d^\alpha x(t)}{dt^\alpha} \right\rangle_T \quad (21)$$

For each Buck converter variable, the averaged value can be described as follows:

$$\langle i_L(t) \rangle = I_L + \hat{i}_L(t) \quad , \quad \langle v_c(t) \rangle = V_C + \hat{v}_c(t) \quad (22)$$

$$\langle v_{in}(t) \rangle = V_{in} + \hat{v}_{in}(t) \quad , \quad \langle d(t) \rangle = D + \hat{d}(t)$$

I_L, \hat{i}_L are the DC and AC components of the inductor current, respectively.

According to (21), the (22) averaged state space model of the DC/DC Buck converter can be obtained.

$$\begin{bmatrix} \frac{d^\alpha \langle i_L(t) \rangle}{dt^\alpha} \\ \frac{d^\beta \langle v_c(t) \rangle}{dt^\beta} \end{bmatrix} = \begin{bmatrix} 0 & -\frac{1}{L} \\ \frac{1}{C} & -\frac{1}{RC} \end{bmatrix} \begin{bmatrix} \langle i_L(t) \rangle \\ \langle v_c(t) \rangle \end{bmatrix} + \begin{bmatrix} \langle \frac{d(t)}{L} \rangle \\ 0 \end{bmatrix} \langle v_{in}(t) \rangle \quad (23)$$

Equation (24) is concluded by substituting the averaged value of the variables in (23).

$$\begin{bmatrix} \frac{d^\alpha (I_L + \hat{i}_L(t))}{dt^\alpha} \\ \frac{d^\beta (V_C + \hat{v}_c(t))}{dt^\beta} \end{bmatrix} = \begin{bmatrix} 0 & -\frac{1}{L} \\ \frac{1}{C} & -\frac{1}{RC} \end{bmatrix} \begin{bmatrix} I_L + \hat{i}_L(t) \\ V_C + \hat{v}_c(t) \end{bmatrix} + \dots \quad (24)$$

$$\dots \begin{bmatrix} \frac{D + \hat{d}(t)}{L} \\ 0 \end{bmatrix} [V_{in} + \hat{v}_{in}(t)]$$

5. DC analysis

In the DC analysis, the AC value of variables will be omitted, and each averaged value is substituted by its DC component. Due to being zero in the Caputo derivative of DC component, the following equations can be achieved:

$$0 = A \begin{bmatrix} I_L \\ V_C \end{bmatrix} + BU \quad (25)$$

$$\begin{bmatrix} I_L \\ V_C \end{bmatrix} = -A^{-1}BU \rightarrow \begin{bmatrix} I_L \\ V_C \end{bmatrix} = - \begin{bmatrix} -\frac{L}{R} & C \\ -L & 0 \end{bmatrix} \begin{bmatrix} \frac{D}{L} \\ 0 \end{bmatrix} V_{in} \quad (26)$$

Finally,

$$\rightarrow \begin{bmatrix} I_L \\ V_C \end{bmatrix} = \begin{bmatrix} \frac{DV_{in}}{R} \\ DV_{in} \end{bmatrix} \quad (27)$$

6. Small signal analysis

In fact, it is possible to omit the derivative of the DC component of variables and multiplied small signal component in the small signal analysis [14].

$$\frac{d^\alpha \hat{i}_L(t)}{dt^\alpha} = \frac{1}{L} (-\hat{v}_c(t) + D \hat{v}_{in}(t) + \hat{d} V_{in}) \quad (28)$$

$$\frac{d^\beta \hat{v}_c(t)}{dt^\beta} = \frac{1}{C} (\hat{i}_L(t) - \frac{1}{R} \hat{v}_c(t)) \quad (29)$$

Equation (30) indicates the averaged state space model of small signal analysis.

$$\begin{bmatrix} \frac{d^\alpha \hat{i}_L(t)}{dt^\alpha} \\ \frac{d^\beta \hat{v}_c(t)}{dt^\beta} \end{bmatrix} = \begin{bmatrix} 0 & -\frac{1}{L} \\ \frac{1}{C} & -\frac{1}{RC} \end{bmatrix} \begin{bmatrix} \hat{i}_L(t) \\ \hat{v}_c(t) \end{bmatrix} + \begin{bmatrix} \frac{D}{L} \\ 0 \end{bmatrix} \hat{v}_{in}(t) + \begin{bmatrix} \frac{V_{in}}{L} \\ 0 \end{bmatrix} \hat{d}(t) \quad (30)$$

The transfer functions help engineers to analyze circuits linearly, and then impose the results obtained on a non-linear and exact circuit. By assuming a zero initial condition and using the definition for the Caputo derivative, calculation of the transfer functions for a DC/DC Buck converter is possible.

Laplace transform was imposed to (28) and (29).

$$s^\alpha \hat{i}_L(s) = -\frac{1}{L} \hat{v}_c(s) + \frac{D}{L} \hat{v}_{in}(s) + \frac{V_{in}}{L} \hat{d}(s) \quad (31)$$

$$s^\beta \hat{v}_c(s) = \frac{1}{C} \hat{i}_L(s) - \frac{1}{RC} \hat{v}_c(s) \quad (32)$$

$$\rightarrow \hat{i}_L(s) = Cs^\beta \hat{v}_c(s) + \frac{1}{R} \hat{v}_c(s)$$

Equation (32) substitutes (31) in order to calculate the transfer function of \hat{V}_o to \hat{V}_{in} ; $\hat{d}(s)$ is considered zero.

$$s^\alpha (Cs^\beta \hat{v}_c(s) + \frac{1}{R} \hat{v}_c(s)) = -\frac{1}{L} \hat{v}_c(s) + \frac{D}{L} \hat{v}_{in}(s) \quad (33)$$

$$\rightarrow \hat{v}_c(s) (Cs^{\alpha+\beta} + \frac{1}{R} s^\alpha + \frac{1}{L}) = \frac{D}{L} \hat{v}_{in}(s)$$

Thus:

$$G_{\hat{v}_o-\hat{v}_{in}} = \left. \frac{\hat{v}_o(s)}{\hat{v}_{in}(s)} \right|_{\hat{d}(s)=0} = \frac{D}{LCs^{\alpha+\beta} + \frac{L}{R} s^\alpha + 1} \quad (34)$$

Equation (35) was concluded from (32), which shows the transfer function of the capacitor voltage to the inductor current.

$$\hat{v}_c(s) = \frac{\hat{i}_L(s)}{Cs^\beta + \frac{1}{R}} \quad (35)$$

The relationship between the inductor current and the duty cycle can be found easily as follows:

$$s^\alpha \hat{i}_L(s) = -\frac{1}{L} \left(\frac{\hat{i}_L(s)}{Cs^\beta + \frac{1}{R}} \right) + \frac{V_{in}}{L} \hat{d}(s) \quad (36)$$

$$\hat{i}_L(s) \left(s^\alpha + \frac{1}{LCs^\beta + \frac{L}{R}} \right) = \frac{V_{in}}{L} \hat{d}(s)$$

Therefore,

$$G_{\hat{i}_L-\hat{d}} = \left. \frac{\hat{i}_L(s)}{\hat{d}(s)} \right|_{\hat{v}_{in}(s)=0} = \frac{V_{in}}{R} \frac{(RCs^\beta + 1)}{LCs^{\alpha+\beta} + \frac{L}{R} s^\alpha + 1} \quad (37)$$

From (32),

$$\hat{i}_L(s) = Cs^\beta \hat{v}_c(s) + \frac{1}{R} \hat{v}_c(s) \quad (38)$$

$$\rightarrow G_{\hat{v}_c-\hat{i}_L} = \frac{\hat{v}_c(s)}{\hat{i}_L(s)} = \frac{R}{RCs^\beta + 1}$$

7. Experimental and simulation results

In a practical DC/DC Buck converter, fractional modeling is carried out. Using the proposed trial and error method in this case, the fractional order of the system was recognized.

In the proposed method, described in a flowchart, the values for α and β during a specific interval were changed, and the results achieved were compared with the practical data, and then the best values for α and β , which can minimize the error, were obtained.

A Buck converter was located in the wind turbine, and it was not possible to impose the PRB (Pseudo-Random Binary) signal to the converter and measure the output voltage in order to identify the buck converter by means of the common fractional identification methods.

By simulation of the whole wind turbine system in Simulink, and with trial and error, the input voltage and duty cycles were achieved. Now the input voltage and duty cycle are available, and the output voltage, inductor current, battery current, and wind speed are measured in the Binalood site using measurement devices.

$L = 0.236 \text{ mH}$, $C = 47000 \text{ } \mu\text{F}$, $R = 0.1$, $V_{in} = 28\text{-}70 \text{ volts}$, $f = 30 \text{ kHz}$, $\text{Batt. Voltage} = 24 \text{ volts}$.

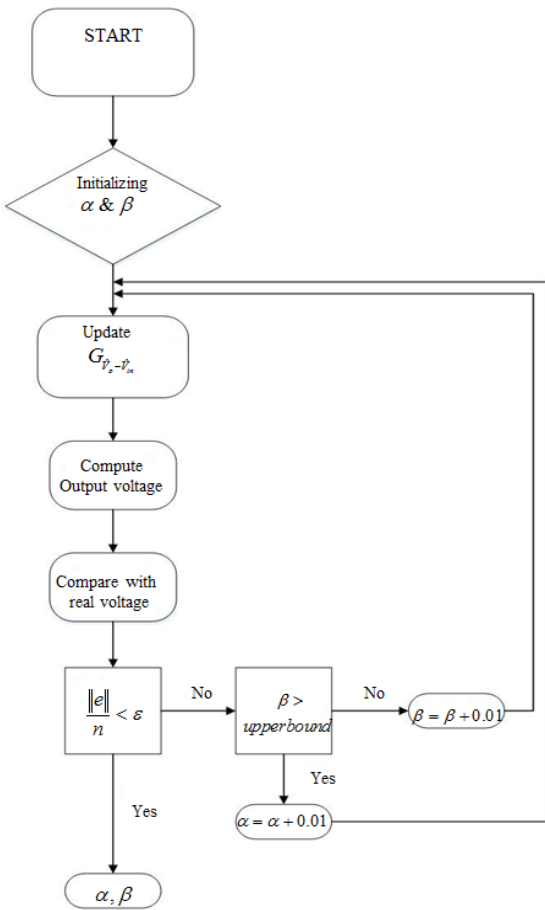

Figure 5. Proposed method flowchart.

A PM (Permanent Magnet) synchronous generator with a 1 kW maximum output power is employed in a wind turbine to produce electricity. The energy produced is rectified by a universal bridge rectifier, and then the rectified voltage connects to the DC/DC Buck converter. The Buck converter plays an important role to charge batteries, and control the charge level and quality. To have a better performance in the control part, it is necessary to prepare a more accurate model for the DC/DC Buck converter.

The measured wind speed in the Binalood site is presented in figure 6.

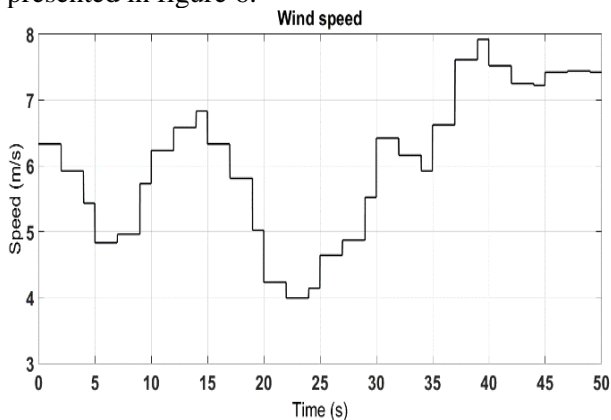

Figure 6. Measured wind speed in Binalood site.

The input voltage and duty cycle are not in hand, and wind speed, battery voltage, and inductor current are measured by a 1 second sample time. The whole wind system is simulated in Matlab in order to achieve the rest of the parameters in Simulink (i.e. input voltage and duty cycle of buck converter). By imposing the wind speed to Simulink and comparing the results obtained with the real output voltage, the input voltage and duty cycle were obtained during 50 seconds.

As stated earlier, accessing a Buck converter is not possible in practice, and simulation is essential for gathering the input voltage and duty cycle of the converter.

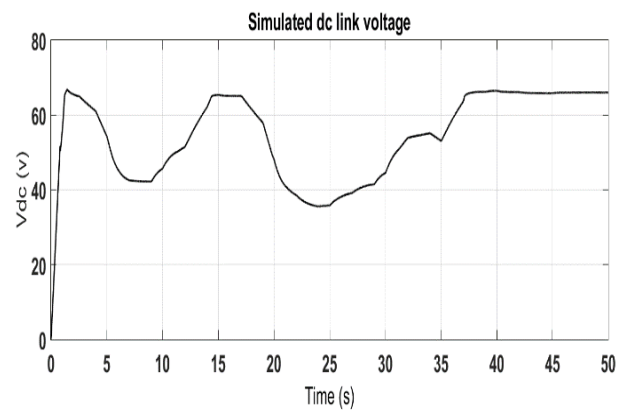

Figure 7. Input voltage of Buck converter gathered by simulation.

During 13 seconds (37-50 s), the input voltage is almost fixed, and in this interval, the duty cycle is about 0.352. As shown in figure 5, the program will be run and all the values for α & β are studied to find the best solution for them. Transfer function of the output voltage to the input voltage is used in this step.

$$G_{v_o-v_{in}} = \frac{\hat{v}_o(s)}{\hat{v}_{in}(s)} \Big|_{\hat{d}(s)=0} = \frac{D}{LCs^{\alpha+\beta} + \frac{L}{R}s^{\alpha} + 1} \quad (39)$$

$$\rightarrow G_{v_o-v_{in}} = \frac{0.352}{0.00001109s^{\alpha+\beta} + 0.00236s^{\alpha} + 1}$$

Both (α, β) change in the range of (0.7-1.3). The best answer for α , which is capable of minimizing the error is 0.9 but different values for β do not affect the error. Figure 8 shows the practical output voltage and the simulated output voltage, in which α and β are considered to be 0.9 and 1, respectively. Although the integer order model in this case study is accurate enough, the fractional order model is a bit more accurate.

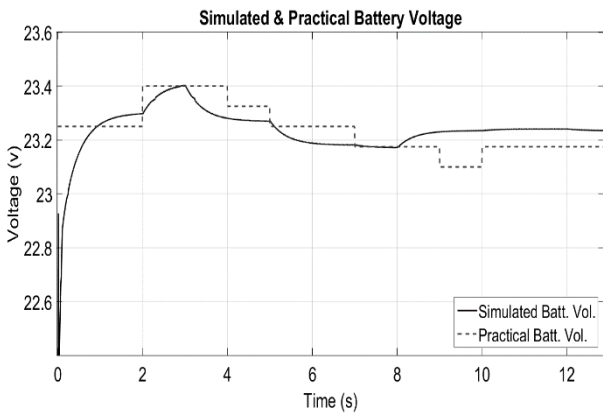

Figure 8. Comparison between simulated and practical battery voltages.

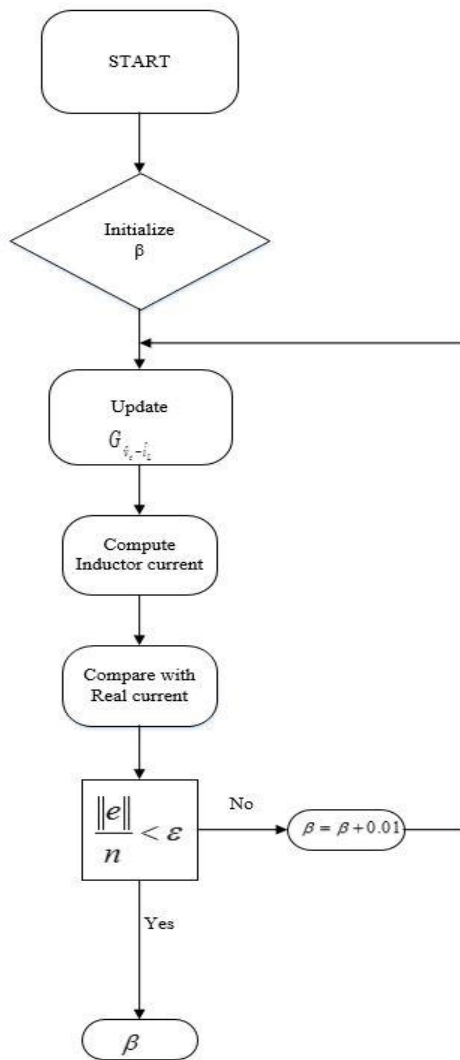

Figure 9. Proposed method flowchart for finding β .

In order to defeat this challenge and find the proper order of β , another transfer function is chosen.

$$G_{\hat{v}_c - \hat{i}_L} = \frac{\hat{v}_c(s)}{\hat{i}_L(s)} = \frac{R}{RCs^\beta + 1} = \frac{0.1}{0.0047s^\beta + 1} \quad (40)$$

The same algorithm is used to search and find the best value for β .

The practical capacitor voltage and inductor current were measured. The DC part of the inductor current and the capacitor voltage are removed, and their AC part are shown as follow. Figure 10 indicates fluctuation of the inductor current, and figure 11 shows the variation in the capacitor voltage.

The algorithm was run with the AC component of the real data, expressed in figures 10 and 11. Although variation in β has a minor effect on the error, $\beta = 0.98$ made the least error. The practical system has a 1-second delay. The Pade approximation approach is employed to model the delay time in Matlab. Equation (41) shows a third-order transfer function, which approximates a 1-second delay.

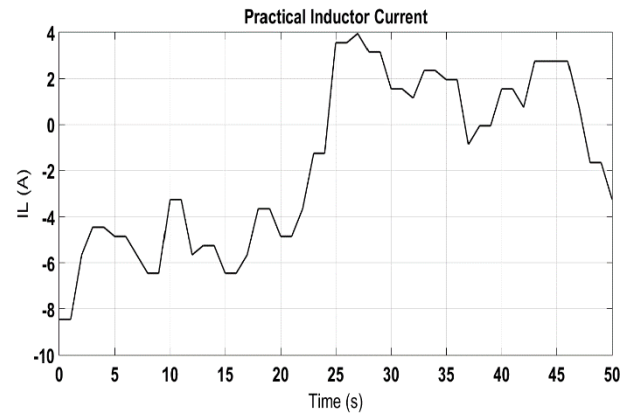

Figure 10. AC part of measured inductor current.

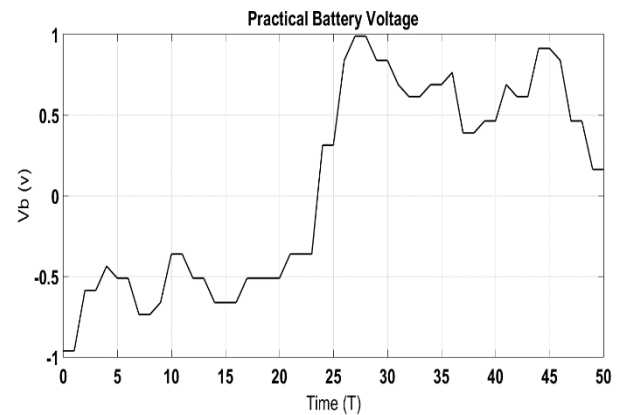

Figure 11. AC part of measured battery voltage.

$$G_{pade}(s) = \frac{-s^3 + 12s^2 - 60s + 120}{s^3 + 12s^2 + 60s + 120} \quad (41)$$

$$G_{\hat{v}_c - \hat{i}_L(\text{delayed})} = \frac{0.1}{0.0047s^\beta + 1} \times \frac{-s^3 + 12s^2 - 60s + 120}{s^3 + 12s^2 + 60s + 120} \quad (42)$$

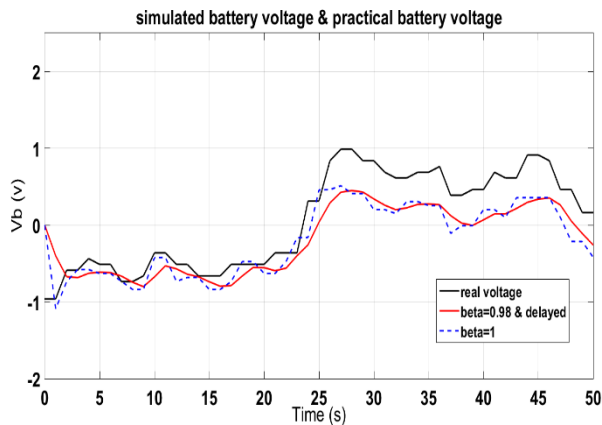

Figure 12. Comparison between practical and simulated battery voltages.

Figure 12 shows the real battery voltage in comparison with the simulated battery voltage with $\beta = 0.98$ in addition to a 1-second delay, and also the simulated battery voltage with $\beta = 1$ without a delay. As it can be seen in this figure, the difference between the integer order transfer function and the fractional order transfer function ($\beta = 0.98$) is inconsiderable because the fractional order of the capacitor is very near to 1 and the integer order is accurate enough but the exact model for transfer function of the capacitor voltage to the inductor current has a fractional behavior in the order of 0.98.

8. Conclusion

A mathematical modeling and an averaged-state space modeling of a DC/DC Buck converter were carried out in this work. Some of the transfer functions were computed. The integer order models are common and usual but the fractional models are not. Although the fractional models are more accurate than the integer-order ones, they are more complicated, and the calculations will be increased. Every system around us is fractional in nature, so paying attention to this fact that all systems are fractional is essential. In this work, it was shown that the fractional modeling of Sun Air Research Center DC/DC Buck converter was a bit more accurate than its integer order model.

The difference between the integer order and the fractional order was not remarkable for this converter because its component order was almost equal to 1. As mentioned in [5-7], the fractional order of the inductor and capacitor was near 1, and the fractional order of the DC/DC Buck converter was near 1 as well because it was made up of these components. However, for some systems not being similar to this kind of converter, the difference between the integer order

and the fractional order may be remarkable, for instance, in such converters made up of inductor and capacitor with a fractional order far away from 1, and financial and social systems. The amount of fractionality for the studied converter was obtained. It was proved that the difference between the integer order and the fractional order in the studied converter was inconsiderable, and a common integer order model could satisfy the modeling accuracy in this particular case study. Fractional order means more accuracy and more complexity in simulation and implementation.

Acknowledgment

The authors wish to express their thanks to the head of Sun Air Research Center of Ferdowsi Mashad University for supporting us in data acquisition from the real system.

References

- [1] Melício R., Mendes V. M. F. & Seixas M., (2014). Offshore Wind Turbine Simulation: Multibody Drive Train. Back-to-Back NPC (Neutral Point Clamped) Converters. *Fractional-Order Control Energy*, vol. 69, pp- 357–369.
- [2] Melício R., Mendes V. M. F. & Catalão J. P. S. (2009). Computer Simulation of Wind Power Systems: Power Electronics and Transient Stability Analysis, *Proceedings of the 2009 International Conference on Power Systems Transients*, Kyoto, Japan — IPST 2009, pp. 1–7.
- [3] Kuo-Yuan L., Yaow-Ming C. & Yung-Ruei Mppt C. (2011). Battery Charger for Stand-Alone Wind Power System. *IEEE Transactions on Power Electronics*, vol. 26, no. 6, pp-1631-1634.
- [4] Mohan N., Udeland M. & Robbins W. P. (1995). *Power Electronics*. New York: John Wiley & Sons, ISBN 0-471-58408-8.
- [5] Jonscher, A. K. (1999). Dielectric Relaxation in Solids. *Journal of Physics D: Applied Physics*. vol. 32, no. 14, pp. 57-70.
- [6] Westerland, S. & Ekstam, L., (1994). Capacitor Theory. *IEEE Transactions on Dielectrics and Electrical Insulation*. vol. 1, no. 5, pp. 826-839.
- [7] Westerlund, S. (2002). *Dead Matter Has Memory!* (Kalmar, Sweden: Causal Consulting), chapter 7.
- [8] Chandran, R., Prasad, V. & Vincent, P., (2014). Modeling of Fractional Order Buck-Boost Converter. *International Journal of Engineering and Advanced Technology (IJEAT)*. vol. 3, no. 3, pp. 129-133.
- [9] Wang, F. & Ma, X. (2013). Modeling and Analysis of the Fractional Order Buck Converter in DCM Operation by Using Fractional Calculus and the Circuit-Averaging Technique. *Journal of Power Electronics*. vol. 13, no. 6, pp. 1008-1015.

- [10] Ning-Ning, Y., Chong-Xin L. & Chao-Jun W., (2012). Modeling and Dynamic Analysis of the Fractional-Order Buck-Boost Converter in Continues Conduction Mode. Chinese Physical Society and IOP Publishing Ltd. 2012, vol. 21, no. 8, pp. 1-7.
- [11] Monje, C. A., et al. (2010). Fractional-order systems and controls: fundamentals and applications. London: Springer, ISBN 978-1-84996-334-3.
- [12] Karanjkar, D. S., Chatterji, S. & Venkateswaran, P. R., (2012). Trends in Fractional Order Controllers. International Journal of Emerging Technology and Advanced Engineering. vol. 2, no. 3, pp. 383-389.
- [13] Valerio, D. & Costa J. S. (2011). Introduction to Single-Input, Single-Output Fractional Control. IET Control Theory & Applications. vol. 5, no. 8, pp. 1033-1057.
- [14] Namjoo, N. & Hajizadeh, A. (2015) In-Direct Adaptive Control of Non-Inverting Buck-Boost Converter. MSc Thesis, Shahrood University of Technology Faculty of Electrical and Robotic Engineering. Supervisor.
- [15] Mahmood A. K. & Mohammed B. F., (2013). Design Optimal Fractional Order PID Controller Utilizing Particle Swarm Optimization Algorithm and Discretization Method. International Journal of Emerging Science and Engineering (IJESE). vol. 1, no. 10, pp. 87-92.

تحلیل و مدل سازی مرتبه کسری مبدل کاهنده در مد عملکردی پیوسته

علی مشار موحد^۱، حیدر طوسیان شاندریز^{۲*} و سید کمال حسینی ثانی^۳

^۱ دانشکده مهندسی برق و ریاضیات، دانشگاه صنعتی شاهرود، شاهرود، ایران.

^۲ گروه برق دانشگاه فردوسی مشهد، مشهد، ایران.

ارسال ۲۰۱۵/۱۱/۱۴؛ بازنگری ۲۰۱۶/۰۵/۲۷؛ پذیرش ۲۰۱۶/۰۸/۲۶

چکیده:

در این مقاله مدل میانگین مرتبه کسری برای مبدل کاهنده DC/DC در مدل عملیاتی پیوسته از یک سیستم توربین بادی پیشنهاد می شود. مبدل کاهنده DC/DC یکی از مولفه های اصلی سیستم توربین بادی مستقل از شبکه می باشد. بدلیل بعضی محدودیت های عملی ولتاژ ورودی و تناوب کاری مبدل در اختیار نیست، بنابراین با استفاده از شبیه سازی کل سیستم بادی بوسیله رایانه داده مورد نیاز برای مدل سازی مرتبه کسری مبدل بر اساس سعی و خطا بدست می آید. رابطه آشکاری بین کیفیت کنترل کننده و مدل ریاضی وجود دارد. مدل دقیق تر منجر به کنترل کننده بهتر می شود. این گفته ها با شبیه سازی انجام شده در این کار اثبات شده است.

کلمات کلیدی: حسابان کسری، مبدل کاهنده، مدل مداری متوسط، توربین بادی.