

Multifunctional Sulfide Catalysts in the Processes of Hydropurification and Hydroisomerisation of Gasoline and Diesel Oil Fractions

B.Tuktin and G.D.Zakumbaeva*

D.V.Sokolsky Institute of Organic Catalysis and Electrochemistry,
142 Kunaev St., 480100 Almaty, Kazakhstan

Abstract

Modified aluminonickel molybdenum catalysts are studied in hydropurification and hydroisomerisation process of gasoline and diesel oil fractions. Catalysts were tested on flow reactor at the temperature 593 – 673K, pressure 2,0-4,5 MPa, 2-7 hours⁻¹ feed velocity. It was shown that synthesized catalysts have polyfunctional properties and they allow to obtain low sulfurous gasoline and diesel fuel with improved characteristics.

Introduction

Many countries, including Kazakhstan, have great amount of sulfurous and paraffin oils. Sulfurous compounds pass to oil light fractions at the distillation. Sulfur content increases with rising of oil fraction boiling point. For obtaining of high quality motor fuel from sulfurous oil it is necessary to apply hydrodesulfurization and hydropurification processes. At these processes sulfurous and nitrogenous compounds are removed from oil fractions, the quality and stability of fuel are improved, corrosion of oil processing equipment is decreased and contamination of environment is reduced [1-4].

Creation of new multifunctional catalysts that are able to carry out the processes of hydropurification and hydroisomerisation of hydrocarbons simultaneously is the perspective task [5,6].

Searching and selection of new effective catalysts that are able to supply deep hydropurification and high quality to oil products are perspective tasks. Selection of optimal characteristics of process and catalysts depends on type of processing oil. Nowadays, World leading companies carry out the elaborating of catalysts for hydropurification and hydroisomerization of different concrete type of raw materials [1,2,5].

Experimental

The catalysts were prepared by modification of alumino-nickel-molybdenum catalysts with decationized zeolite and other additives. The catalysts prepared by impregnation of γ -Al₂O₃ with aqueous solution of ammonium paramolybdate nickel nitrate and introduction of modifying additives. Impregnated mass was formed, dried at 393-423 K (4 hours) and calcinated at 823 K during 5 hours. Catalysts were activated by free sulfur at 393-423 K, 0,5-0,7 MPa hydrogen pressure during 3 hours, then sulfidated carried out at 473 K, 2,5 MPa during 2,5-3,0 hours. The synthesized catalysts were tested in the processes of hydrodesulfurization, hydropurification and hydroisomerisation of gasoline and Diesel oil fractions on flow reactor at 593-673K, 2,0-4,5MPa and 2-7 hours⁻¹ feed velocity. The products of reaction were analyzed by GLC-method.

Results and discussion

The activity of catalysts is different and depends on nature of modified additives (see Table 1). Results obtained by industrial ANM catalysts are shown for comparison. Catalysts KT-1 ÷ KT-10 are the zeolite containing systems modified by rare-earth elements and other additives. Hydrodesulfurization activity of the designed catalysts is sig-

*corresponding author. E-mail:adm@orgcat.academ.alma-ata.su

nificantly higher than this of ANM industrial catalyst at the same conditions. The most hydro- desulfurization and hydroisomerization activities are observed on KT-10 catalyst. The desulfurization degree of KT-10 catalyst is 97,7% at 653K ($P_{H_2} = 3,5\text{MPa}$, feed velocity = 6 hours⁻¹) that is higher than activity of industrial catalyst by 16% at the same conditions of experiments. Hydro- desulfurization activity of catalyst increases by 9,0-15,0% with increasing of

temperature from 593 to 673K as it can be seen from the data of Table 1. Hydrodesulfurization degree is negligible increasing when the temperature of process higher than 673K. Residual content of sulfur in reaction products is 0,01-0,02% at using of modified catalysts at 653K that correspondings to Europe standards for sulfur content in diesel fuel. Freezing and cloud point of obtained Diesel fuel decrease by 4,7-27,5 degrees that allow to produce winter sorts of Diesel fuel.

Table 1

Influence of temperature on hydrodesulfurization degree and point of congelation of Diesel fuel at $P_{H_2} = 3,5\text{ MPa}$ and feed velocity = 6 hours⁻¹.

No	Catalysts	Temperature, K	Hydrodesulfurization degree, %	Point of congelation, K
1	Initial diesel fuel			258,0
2	ANM - industrial	593	75,0	257,8
		623	77,9	257,7
		653	81,7	257,7
		673	84,0	257,7
3	Kt - 7	593	80,1	253,3
		623	86,1	257,3
		653	93,2	249,9
		673	95,1	247,3
4	Kt - 8	593	82,0	252,3
		623	91,1	250,1
		653	93,2	248,5
		673	95,8	245,8
5	Kt - 9	593	88,7	249,8
		623	92,3	245,7
		653	96,3	242,8
		673	98,2	240,8
6	Kt - 10	593	89,1	238,6
		623	94,7	233,8
		653	97,7	231,0
		673	98,5	230,5

The study of influence of raw material feed velocity on KT-10 catalysts shows (Table 2) that increasing of feed velocity from 2 to 6 hour⁻¹ leads to negligible decreasing of hydrodesulfurization activity. Increasing of feed velocity to 7 hour⁻¹ results in decreasing hydrodesulfurization degree from 98,5 to 96,3%, that is owing to decreasing of contact time of raw material with active centers of the catalyst. Contrary to the industrial catalyst KT-10 preserve high hydrodesulfurization and hydroisomerisation activities even at higher feed velocities (Table 2).

Increasing of hydrogen pressure results in increasing of hydrodesulfurization degree (Table 3). With increasing of hydrogen pressure from 2,0 to 3,5 the hydrodesulfurization degree increases from 92,7% to 98,5%. Further increasing of pressure increases the hydrodesulfurization degree negligibly.

The most intensive increasing of hydrodesulfurization degree at hydrodesulfurization and hydroisomerisation of gasoline oil fraction (Table 4) is observed in the interval of temperatures 593-653K. The degree of gasoline purity on studied

Table 2

Influence of feed velocity on hydrodesulfurization degree and point of congelation of Diesel fuel at $T = 653\text{K}$, $P_{\text{H}_2} = 3,5\text{ MPa}$

No	Catalysts	Feed velocity, hours ⁻¹	Hydrodesulfurization degree, %	Point of congelation, K
1	Initial diesel fuel			258,0
2	ANM - industrial	2	88,0	257,7
		3	85,7	257,7
		4	84,6	257,7
		5	83,0	257,8
		6	81,0	258,0
		7	78,1	258,0
3	Kt -10	2	98,5	229,5
		3	98,4	230,3
		4	98,2	230,6
		5	98,0	230,8
		6	97,7	231,0
		7	96,3	231,5

Table 3

Influence of hydrogen pressure on hydrodesulfurization degree and point of congelation of Diesel fuel at $T=673\text{ K}$ and feed velocity = 6 hours⁻¹.

Catalysts	Hydrogen pressure, MPa	Hydrodesulfurization degree, %	Point of congelation, K
Kt -10	2,0	92,7	234,4
	3,0	95,8	232,7
	3,5	97,7	231,0
	4,0	98,2	230,8
	4,5	98,5	230,5

catalysts is higher than at hydrodesulfurization on diesel fraction. Obviously, it is stipulated by prevalence of light mercaptans in gasoline oil fraction. Among the modified ANM-catalysts the KT-9, KT-10 catalysts have the maximum activity at hydrodesulfurization and hydroisomerisation of gasoline and diesel oil fraction for which the desulfurization degree is 97 - 98,5% at $T = 653\text{K}$. The isomerisation degree of $\text{C}_6\text{-C}_9$ alkanes contained in gasoline and Diesel oil is 24,6-44,1% depending on nature of catalysts and process conditions. The octane number of straightrun gasoline has increased to 76,5 due to isomerisation of alkanes.

The synthesized catalysts have polyfunctional properties (Fig. 1,2). These catalysts carry out not only hydrodesulfurization but hydrogenation of alkenes and isomerisation n-alkanes to iso-alkane.

Table 4

Influence of temperature on hydrodesulfurization degree of fractionating gasoline at $P_{\text{H}_2} = 3,5\text{ MPa}$, feed velocity = 6 hours⁻¹.

No	Catalysts	Temperature, K	Hydrodesulfurization degree, %
1	ANM - industrial	593	79,5
		623	85,2
		653	88,1
		673	90,1
2	Kt - 7	593	84,0
		623	90,3
		653	94,2
		673	95,5
3	Kt - 8	593	86,1
		623	89,8
		653	97,0
		673	97,5
4	Kt - 9	593	89,0
		623	93,1
		653	97,9
		673	98,8
5	Kt -10	593	89,6
		623	95,0
		653	98,0
		673	98,7

Application of the multifunctional catalysts enables to produce low-sulfur gasoline and diesel fuel with improved characteristics.

Our catalysts will be used on miniplants for pro-

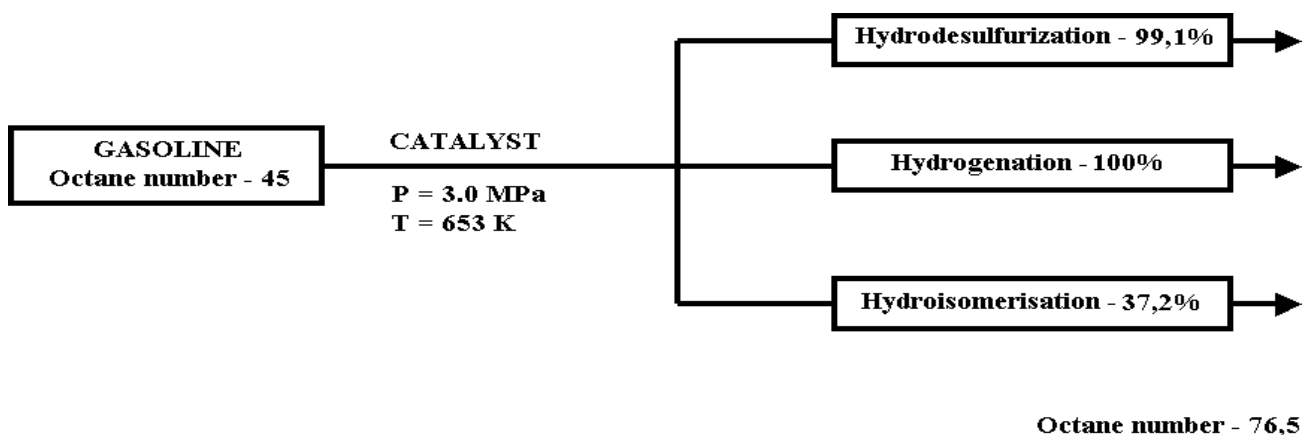

Fig.1. The multifunctional catalyst of hydrorefining and hydroisomerisation of gasoline.

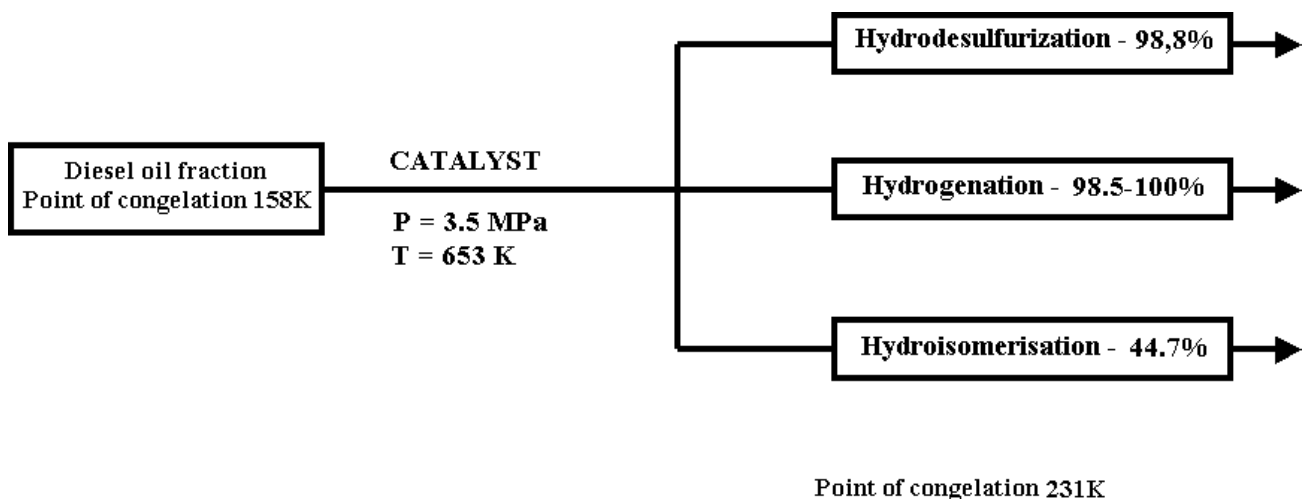

Fig.2. The multifunctional catalyst of hydrorefining and hydroisomerisation of diesel oil fraction.

ducing of environmentally friendly low-sulfur motor fuels. We suppose that our catalysts KT-9, KT-10 will be tested on two oil-processing plants of China according to requests of Chinese specialists.

Reference

1. B.D. Radchenko, B.K. Nefedov, R.R. Aliev. Promyshlennye katalizatory gidrogenizatsionnykh processov neftepererabotki.: *Chimia*. 1987, p.224
2. B.K. Nefedov, B.D. Radchenko, R.R. Aliev. Katalizatory processov uglublennoi pererabotki neftei: *Chimia*. 1975, p. 265.
3. Y.G. Sorkin. Osobennosti pererabotki sernistyykh neftei i ochrany okruzhayushchei sredy. M.: *Chimia*. 1975, p. 297.
4. Sh. Tomos. Promyshlennye kataliticheskie processy i effektivnye katalizatory. M.: Mir, 1973. p.386
5. O.V. Barsukov, B.L. Talisman, R.K. Nasirov. O perspektivnykh katalizatorakh gidroochistki neftyanykh fraktsii. *Neftepererabotka i neftekhimiya*. 1996. No9. p.14-27
6. B.Tuktin, B. Selenova, G.D. Zakumbaeva. Hidroochistka dizelnykh i benzinovykh fraktsii neftei na polyfunktsionalnykh katalizatorakh. *Doklady Ministerstva nauki-Akademii nauk Respubliki Kazakstan*, 1997, No3, p.46-50.

Received 7 January 2000.