

The investigation on high-rise building tilting from the issue of land subsidence in Jakarta City

Heri Andreas^{1*}, Hasanuddin Zainal Abidin¹, Dina Anggreni Sarsito¹, and Dhota Pradipta¹

¹Geodesy Research Division, Faculty of Earth Science and Technology, Institut Teknologi Bandung, Bandung, Indonesia

Abstract. One of the issues from land subsidence consequences is tilting on building. At the places where differential subsidence is existed we might literally see the building tilted. Jakarta is a mega city in Indonesia where significant land subsidence (e.g. 1-26 centimeter per year) is happening today. Issue of tilting on buildings due to land subsidence in Jakarta has been raisin. There is one high-rise building namely Menara Saidah which is judging to be tilting. As consequences the building has been abandoned. The building in the office of House of Representative is also being rumored to be tilting. Judging and rumored are not scientific, we need real measurements. There are more than two hundreds of high-rise buildings established in Jakarta city. We use the Terrestrial Laser Scanner survey to investigate the issue of high-rise building. This technology has capability to create 3D object with milimeter accuracy. Tilting on the building can be seen simply by their verticality. We have chosen several high-rise buildings to accurately measure, especially where large subsidence is there. This paper is a highlight on the investigation. As the conclusion we found the verticality of investigated buildings are still within the tolerance.

1 Introduction

After around twenty years since its development, a high-rise building called Menara Saidah in southern part of Jakarta city has been suddenly abandoned. A rumor of tilting on the building was rapidly spread out. Parking yard indeed was experiencing some cracks and unlevelled. Nobody would dare to enter the building anymore and so the owner experiencing financial loss from building rental, event, etc. In the early 2000 the building of the House of Representative of Indonesia located in west Jakarta has been suggested to be demolished and replace by the new one because the rumor of tilting. The land subsidence is believed to be the cause of tilting on the building. In the northern part of Jakarta, an Old Dutch building is indeed tilted quite sharply (figure 1) where area surrounding suffering land subsidence with significant rate.

In accordingly land subsidence is quite well known phenomenon for Jakarta. The occurrence of land subsidence was recognized at least in the early the development of the city up to now. The evidence for subsidence was clearly note based on repeated leveling measurements, GPS surveys, InSAR measurements, extensometer, etc. According to some publications (e.g. Murdohardono and Tirtomihardjo [1]; Abidin *et al.* [2,3]; Koudogbo *et al.* [4] the yearly value of Jakarta's subsidence generally ranging from 1 to10 centimeter per-year and may reach 20-26 centimeter in certain

place, especially in northern part of Jakarta for the recent years.

Instead of only rumors, investigation on high-rise building from the issue of land subsidence in Jakarta is necessary. Perhaps the tilting is indeed only rumors or we have quantitative evident of the tilting. This information will be quite useful for either adaptation or mitigation if somehow started from tilting and would end up with collapse for instance. Terrestrial Laser Scanner (TLS) is one of technology which can accurately sense the tilting if existed.



Fig. 1. An Old Dutch building in northern part of Jakarta city which is experiencing tilting quite sharply

* Corresponding author: heri@gd.itb.ac.id

2 Methods

The capability of generating millions of point clouds with few millimeter accuracies for range up to few hundred meters and even reached 1 kilometer from device to object target is one factor of Terrestrial Laser Scanner being a leading technology in close range area mapping (Quintero *et al.* [5]; Barber & Mills [6-7]). Radar pulse generated to measure distance while automatic mirror create azimuth between object and the device (figure 2). From these mechanisms through mathematical calculation (e.g. polygon) it can produce of millions of point cloud with each represents by tree dimension coordinates in millimeter accuracy. Geometry of 3 Dimensional of an object can be created through these scan process. Tilting of an object as objective of this paper can be analyzing form the 3D geometry shape analysis.

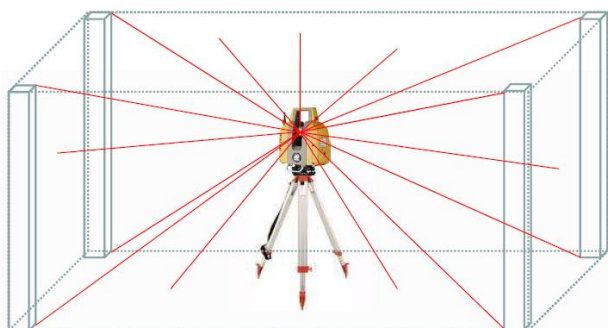

Fig. 2. Radar pulse generated to measure distance while automatic mirror created azimuth between object and TLS device. By calculation millions of point cloud may generated.

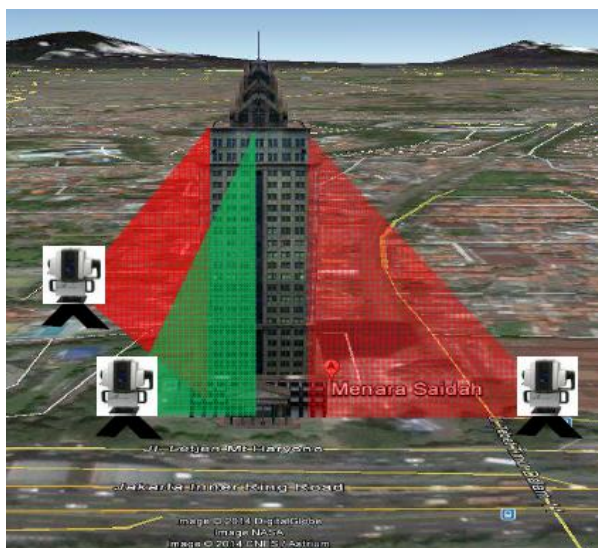

Fig. 3. Illustration of scan position to measure point cloud of an object being investigated

Several scan position is needed to set up in order to measure point cloud of an object being investigated (see figure 3). From one simply building it is usually needed 5 to 6 six scan positions. To connect one scan to the others we do registration or geo-reference process either using geo-reference coordinates or object to object

identification (Reshetyuk [8]). GNSS (Global Navigation Satellite System) is generally used to help geo-reference of TLS. With using GNSS, in this case 3D model product attach to National or even international spatial reference system. If local coordinates are sufficient, therefore measuring polygon by Total Station is enough to help registration process.

From the acquisition until creation of 3 D model, there are four main processes (see figure 4) namely scan process and saving millions of point clouds (figure 5), registration or geo-referencing, filtering, and finally 3D modeling (figure 5). During modeling we can also do some filling on the missing point clouds etc. Filtering is taken to reduce the noise on the object being scanned. Filtering can be done manually or automatic or both combination. The successful of registration, filtering and modeling can give 3 D object model accuracy in millimeters to centimeters level.

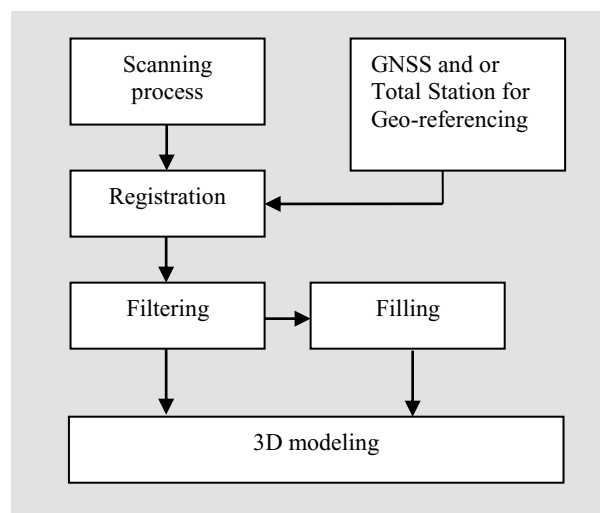

Fig. 4. TLS processes from scanning and saving point clouds up to generating 3D model



Fig. 5. Illustration of point cloud and 3D model

As for the aim of the paper, we will do scanning in several buildings around Jakarta city. The building chooses from the issue arised as well as related to the subsidence value nearby. Large subsidence perhaps would give consequence to building's tilting. We choose Menara Saidah, The House of Representative, Aston Apartment, MOI Apartment and MNC building. The building location can be seen in figure 6 along with land subsidence map.

As mentioned above we would try to answer the rumors of high-rise building tilting in Jakarta city due to the impact from the land subsidence. If indeed it is existed, therefore risk of disaster is also existed. Tilting leading to collapse may produce disaster.

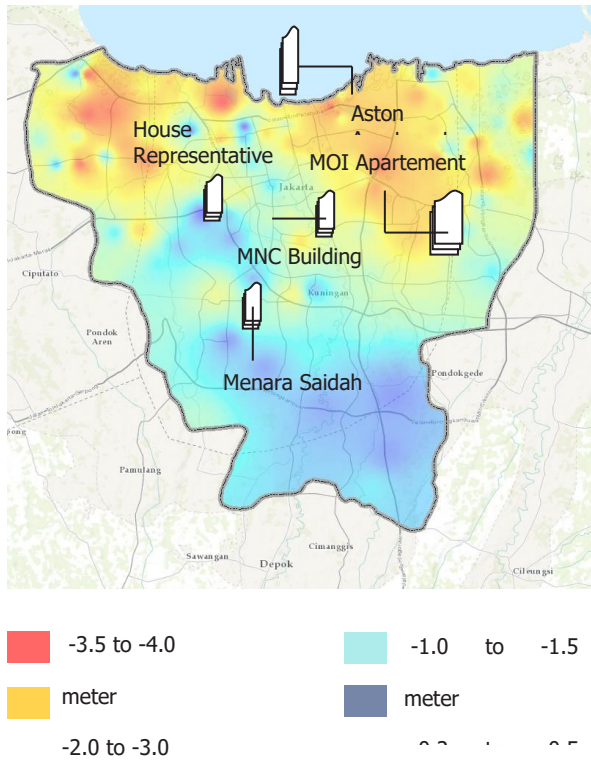

Fig. 6. Map of land subsidence in Jakarta from 1925 to 2015 base on integration of leveling measurements data, GPS surveys, and InSAR overlay with high-rise building for tilt investigation.

Figure 7 is documentation of data acquisition in the field. We use MAPTECH long range Terrestrial Laser Scanner. It has the capabilities of catching the object from laser beam up to 1 kilometer distance with millimeter to few centimeter accuracy depend on best registration, etc. Thousand of point cloud is generated only in less than one second scanning. For geo-reference we use combination of GNSS Topcon dual frequency geodetic receiver and Total Station with position accuracy reached two millimeter.



Fig. 7. Documentatation of Terrestrial Laser Scan data acquisition in the field for tilting of building investigation around Jakarta city.

The size of the buildings being investigated are around 400 meter square to 600 meter. The stories vary between 20 to 40 stories. They are categorize at least as minimum of high-rise buiding ini Indonesia. The scan process for each building were about 6 to 28 scan positions, it is depend on complexity of building shape. One building need half day of complete data acquisition.

To see the tilting on the building using TLS survey is as simple by seeing both axis X and Y on the 2D model coordinates system. The X will represent the nivo level while the Y represents verticality. Degree of 90 calculated from X axis to Y axis will represent zero tilting. Figure 8 is shown the illustration on how the building with zero tilting or in tilting condition.

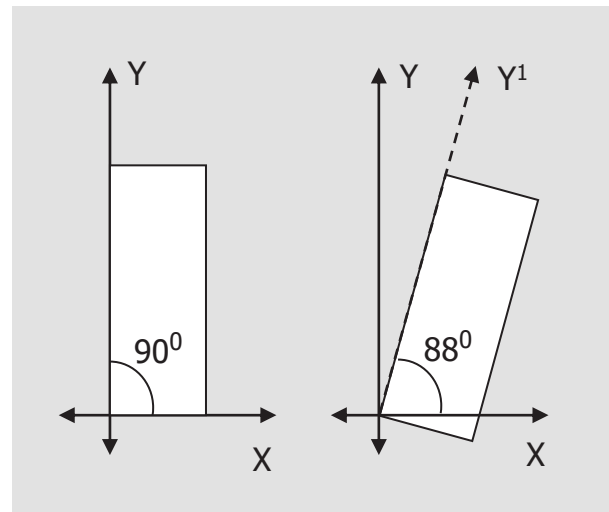

Fig. 8. Illustration on how the building with zero tilting or in tilting condition

3 Results

Below in sub-chapter 3 we can see the result of tilting investigation on each buildings being investigated. We will show the X and Y axis results along with degree of tilting. First in Table 1 we can highlight the quality of TLS cloud data registration as well as an indicator for the 3 D modeling result. The averages of RMS for cloud registration were noted in only order of few centimeters. These results indicated good modeling produce by the TLS surveys and support the good analysis of tilting.

Table 1. Summary of average of RMS for cloud registration to show quality of 3D model object investigation

No	Location	Numbers of scan position	Average of RMS for cloud registration (in millimeter)
1	Menara Saidah	28	15
2	Aston Buildings	7	11
3	MOI Buildings	10	12
4	MNC Building	6	12

3.1 Menara Saidah Building

As mentioned previously, Menara Saidah building is one famous rumored of tilted high-rise building in Jakarta. Due to this rumor the building has been abandon. Loss of income is received by the owner without the real true of measurement, but only from rumor. Nobody would like to rent rooms on the building and or held an event anymore. We take initiatives to measure this building by using TLS survey. Note that 10 scan positions were taken to collect point clouds of building geometry while another 18 scan position measure 6 chosen floors as sample for tilting investigation in each floor. Figure 9 shows pictures of 3 different side of model of Menara Saidah along with X and Y axis drawing and angle of tilt calculation, while figure 10 shows pictures of 2 side of peak building of Saidah along with X and Y axis drawing. To see the tilting it might be easier from the peak side.

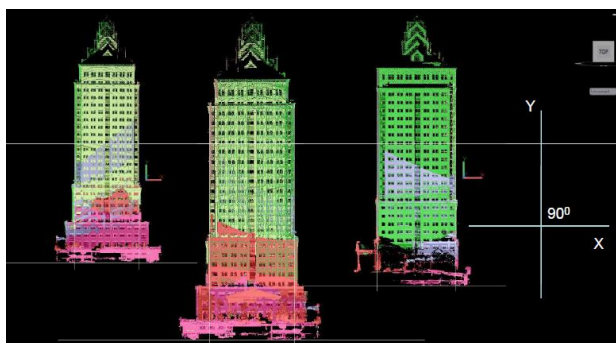

Fig. 9. Model of Menara Saidah from 3 different side along with X and Y axis and angle of tilt calculation.

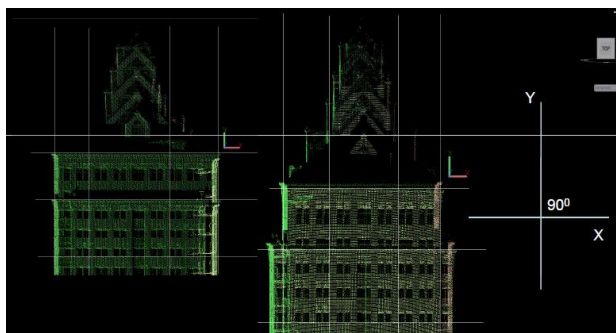

Fig. 10. Model of Peak of Menara Saidah from 2 different side along with X and Y axis and angle of tilt calculation. To see the tilting it might be easier from peak side.

Figure 11 and 12 shows TLS model taken from each chosen floor. We draw the X and Y axis and tilt calculation. We did calculation to the level of each corner of the floor with respect to one and each others. If no or less different on their relative level, in this case no tilting concluded on the building. Result from the investigation shows that the building has zero tilting (90 degree between X and Y axis), means that there is no tilting on the building. No significant different on relative level on the floor has given another conclusion of no tilting on Menara Saidah building so far.

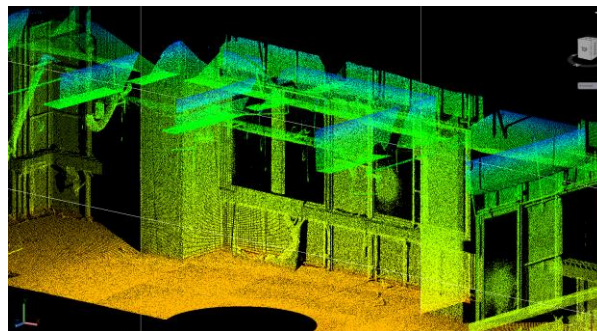

Fig. 11. The example of TLS model (registered and filtered) on sample floor at Menara Saidah to investigate level of the floor and tilting on the building

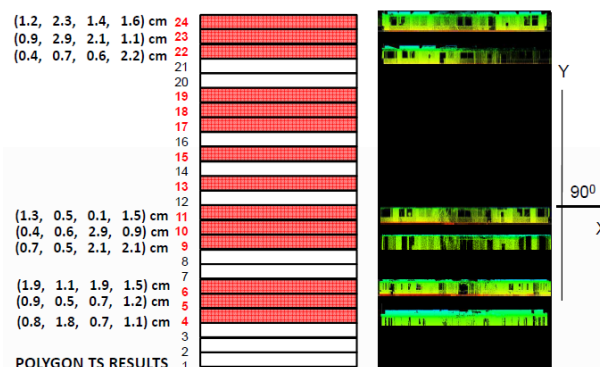

Fig. 12. The result of TLS scanned on each chosen floor and the calculation of level corner of the floor with respect to one and each others.

3.2 ASTON Buildings

ASTON Buildings located in the northern part of Jakarta where significant land subsidence with rates up to 10 centimeter per years is happening. We take initiatives to measure this building by using TLS to see if the significant land subsidence tilted the building. Note that 7 scan positions were taken to collect point clouds of building geometry. Figure 13 shows pictures of 4 model of each Tower of ASTON buildings along with X and Y axis drawing to investigate the tilting, while figure 14 shows pictures of one peak building of along with X and Y axis drawing and angle of tilt calculation.



Fig. 13. Model of 4 tower of ASTON buildings along with X and Y axis to investigate the tilting

Result from the investigation shows that the building has zero tilting (90 degree between X and Y axis), means that there is no tilting on the building and there is no affect even by the significant land subsidence surrounding to their verticality of the building so far.

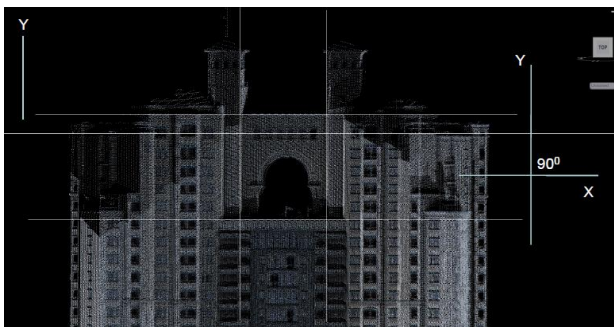

Fig. 14. Model of Peak of one Aston Tower along with X and Y axis and angle of tilt calculation. Zero tilting concluded from the model.

3.3 MOI Buildings

MOI Buildings located in the eastern part of Jakarta where quite significant land subsidence with rate up to 7 centimeter per years is happening. We take initiatives to measure this building by using TLS survey. Note that 10 scan positions were taken to collect point clouds of building geometry. Figure 15 shows pictures of 4 model of each Tower of MOI buildings along with X and Y axis drawing to investigate the tilting, while figure 16 shows pictures of one peak building of along with X and Y axis drawing and angle of tilt calculation.

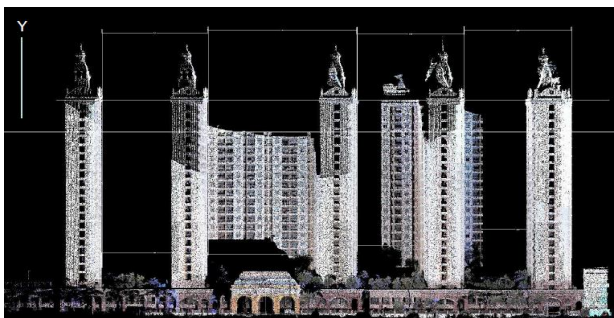

Fig. 15. Model of 4 tower of MOI buildings along with X and Y axis to investigate the tilting

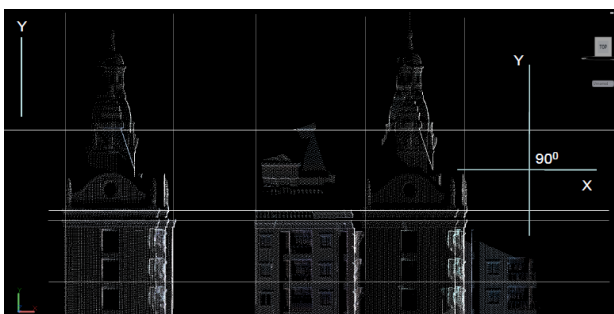

Fig. 16. Model of Peak of one MOI Tower along with X and Y axis and angle of tilt calculation

Result from the investigation shows that the building has zero tilting (90 degree between X and Y axis) even on the peak of the building where it is usually easier to see the tilting, means that there is no tilting on the building and there is no affect even by quite significant land subsidence surrounding to their verticality of the building so far. If the building is indeed affecting by the subsidence, all building subside with the same speed and magnitude.

3.4 Others building

Beside Menara Saidah, Aston Buildings, MOI buildings, as mentioned earlier we initiatively conduct TLS surveys in more buildings like MNC building, House of Representative, etc. Result from the investigation shows that all of the building has zero tilting (90 degree between X and Y axis) even on the peak of the building, means that there are no tilting on the buildings and there are no affect from the land subsidence surrounding to their verticality of the buildings so far. If the building is indeed affecting by the subsidence, all building seems subside with the same speed and magnitude.

4 Discussions

Interesting results have shown that all of the buildings being investigated has zero tilting (90 degree between X and Y axis) even on the peak of the building, means that there are no tilting on the buildings due to land subsidence. The accuracy of model derived from TLS were also on the high accuracy as depicted on table 1, meaning it is good enough for supporting the analysis. So, it turn out the tilting was just a rumor, respectively.

Jakarta city establish above sand and clay mixed sedimentation. With this kind of sub-surface properties, the subsidence will be more likely existed in elastic way rather than rigid. So, if the building is indeed affecting by the subsidence, all building with deep pile foundation seems subside with the same speed and magnitude.

The question remains, in this case what are the impacts of subsidence to the building then? Cracks on the building and flooding to the building due to tidal inundation or heavy rainfall are the answer. Figure 17 to 19 shows the example of subsidence impact to the building and infrastructures in Jakarta city.



Fig. 17. Cracks on the building structures as the impact of land subsidence in Jakarta city.



Fig. 18. Cracks on the road structures as the impact of land subsidence in Jakarta city. Differential subsidence is happening on shallow and deep layer below the ground

Cracks on the building and infrastructures and flooding indeed is getting worse through times in Jakarta city. Eventually huge amount of rupiah have to be spent to fix the building, houses, and the infrastructures and also to reduce the flooding. Dykes have been built along the coastline. Those fixing and establishing are forms of adaptation and mitigation against land subsidence in Jakarta. Unfortunately based on the monitoring the land subsidence is continuing to happen with mostly in linear trend and sign of stop or decreasing is beyond the story for today and even in the near future.

If only we built the dykes and fixing the infrastructures, with the fact of linear trend of subsidence, in this case we always wait for silent disaster to slowly returned given a disaster. Even in the future the tilting on the building it might happen somehow. There are several examples on other cities around the world who manage to stop the land subsidence (e.g. Tokyo and Osaka Japan, Venice Italy, San Joaquin USA, etc.). By stopping the groundwater abstraction, mostly the land subsidence is stopped. Nevertheless stopping groundwater abstraction in Jakarta is still a big homework.



Fig. 19. Documentation of flooding from tidal inundation and rain affected building condition due to land subsidence

5 Conclusions

Land subsidence is quite well known phenomenon for Jakarta. The occurrence of land subsidence was recognized at least in the early development of the city up to now. The evidence for subsidence of rate 1-10 centimeter per year and even higher were clearly notes based on repeated leveling measurements, GPS surveys, InSAR measurements, extensometer, etc. One of the issues from land subsidence consequence is tilting on building. At the places where differential subsidence is existed we might literally see the building tilted. Issue of tilting on buildings due to land subsidence in Jakarta has been raised recently.

In order to prove the issue, we take initiative to measure some buildings in Jakarta city by TLS. We choose buildings like Menara Saidah, The House of Representative, Aston Apartment, MOI Apartment and MNC building. The size of the buildings being investigated are around 400 meter square to 600 meter. The stories vary between 20 to 40 stories. They are categorized at least as minimum of high-rise building in Indonesia. The scan process for each building were about 6 to 28 scan positions, it is depend on complexity of building shape.

Result from the investigation shows that all of the buildings being investigated have zero tilting (90 degree between X and Y axis) even on the peak of the buildings, means that there is no tilting on the building and there is no affect from the land subsidence surrounding to their verticality of the building. If the building is indeed affected by the subsidence, all building with deep pile foundation seems slowly subside with the same speed and magnitude. Mixed sand clay on the sub-surface properties of Jakarta play significant role on this slow subsidence which is not the produce tilting on building so far.

Many thanks and appreciation to ASABA who help collecting TLS data needed for the investigation and also for students in geodesy ITB who helped the survey in the field. Appreciation is also given to college in Geodesy Research Division who support the investigation.

References

1. D. Murdohardono, H. Tirtomihardjo, *Penurunan tanah di Jakarta dan rencana pemantauannya*. In: Proceedings of the 22nd annual convention of the Indonesian association of geologists, Bandung, 6–9 December, pp 346–354 (1993)
2. H. Z. Abidin, *Suitability of levelling, GPS and INSAR for monitoring land subsidence in urban areas of Indonesia*. GIM Int **19**(7):12–15 (2005)
3. H. Z. Abidin, H. Andreas, I. Gumilar, Y. Fukuda, Y.E. Pohan, T. Deguchi. *Land subsidence of Jakarta (Indonesia) and its relation with urban development*. Nat. Hazards **59**(3), 1753–1771(2011)
4. F. N. Koudogbo, J. Duro, A. Arnaud, P. Bally, H. Z. Abidin, and H. Andreas, *Combined X- and L band PSI analyses for assessment of land subsidence in Jakarta*, Proc. SPIE, Remote Sensing for

- Agriculture, Ecosystems, and Hydrology **XIV**, 8531, 853107, doi:10.1117/12.974821 (2012)
5. M.S. Quintero, B.V. Genechten, M.D. Bruyne, P. Ronald, M. Hankar, and S. Barnes, *Theory and Practice on the Terrestrial Laser Scanning*, The Learning Tools for Advanced Three Dimensional Surveying in Risk Awareness Project (3DRiskMapping) (2008)
 6. D. Barber, & J. Mills, *3D Laser Scanning for Heritage: Advice and Guidance to Users on Laser Scanning in Archeology and Architecture*, United Kingdom English Heritage Publishing (2007)
 7. D. Barber, & J. Mills, *3D Laser Scanning for Heritage (second Edition): Advice and Guidance to Users on Laser Scanning in Archeology and Architecture*. United Kingdom English Heritage Publishing (2011)
 8. Y. Reshetyuk, *Terrestrial Laser Scanning, Error Source, Self-calibration, and Direct Georeferencing*. Saarbrücken, Germany: VDM Verlag Dr. Müller (2009)