



RESEARCH ARTICLE

**REVISED** Comparison of the oxidative potential of primary (POA) and secondary (SOA) organic aerosols derived from α-pinene and gasoline engine exhaust precursors [version 2; peer review: 2 approved]

Christopher Lovett <sup>1</sup>, Mohamad Baasiri<sup>2</sup>, Khairallah Atwi<sup>2</sup>, Mohammad H. Sowlat<sup>1</sup>, Farimah Shirmohammadi<sup>1</sup>, Alan L. Shihadeh<sup>2</sup>, Constantinos Sioutas<sup>1</sup>

<sup>1</sup>Department of Civil and Environmental Engineering, University of Southern California, Los Angeles, CA, 90089, USA

<sup>2</sup>Department of Mechanical Engineering, American University of Beirut, Riad El Solh, Beirut, 1107 2020, Lebanon

**v2** First published: 09 Jul 2018, 7:1031  
<https://doi.org/10.12688/f1000research.15445.1>  
 Latest published: 11 Mar 2019, 7:1031  
<https://doi.org/10.12688/f1000research.15445.2>

**Abstract**

**Background:** Primary (POA) and secondary (SOA) organic aerosols, deriving from both anthropogenic and biogenic sources, represent a major fraction of ambient particulate matter (PM) and play an important role in the etiology of respiratory and cardiovascular diseases, largely through systemic inflammation and cellular oxidative stress. The relative contributions of these species to the inhalation burden, however, are rather poorly characterized. In this study, we measured the *in vitro* oxidative stress response of alveolar macrophages exposed to primary and secondary PM derived from both anthropogenic and biogenic sources.

**Methods:** POA and SOA were generated within an oxidation flow reactor (OFR) fed by pure, aerosolized α-pinene or gasoline engine exhaust, as representative emissions of biogenic and anthropogenic sources, respectively. The OFR utilized an ultraviolet (UV) lamp to achieve an equivalent atmospheric aging process of several days.

**Results:** Anthropogenic SOA produced the greatest oxidative response (1900 ± 255 µg-Zyosan/mg-PM), followed by biogenic (α-pinene) SOA (1321 ± 542 µg-Zyosan/mg-PM), while anthropogenic POA produced the smallest response (51.4 ± 64.3 µg-Zyosan/mg-PM).

**Conclusions:** These findings emphasize the importance of monitoring and controlling anthropogenic emissions in the urban atmosphere, while also taking into consideration spatial and seasonal differences in SOA composition. Local concentrations of biogenic and anthropogenic species contributing to the oxidative potential of ambient PM may vary widely, depending on the given region and time of year, due to factors such as surrounding vegetation, proximity to urban areas, and hours of daylight.

**Keywords**

Particulate Matter, SOA, Biogenic PM, Anthropogenic PM, Photochemical Aging

**Open Peer Review**

**Reviewer Status** ✓ ✓

	Invited Reviewers	
	1	2
<b>version 2</b> (revision) 11 Mar 2019		
<b>version 1</b> 09 Jul 2018	✓ report	✓ report

- Barend L. van Drooge** <sup>1</sup>, Institute for Environmental Assessment and Water Research (IDÆA-CSIC), Barcelona, Spain
  - Zhi Ning**, Hong Kong University of Science & Technology, Hong Kong, China
- Any reports and responses or comments on the article can be found at the end of the article.

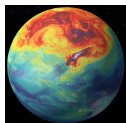

This article is included in the **Climate Action** gateway.

**Corresponding author:** Christopher Lovett ([clovett@usc.edu](mailto:clovett@usc.edu))

**Author roles:** **Lovett C:** Data Curation, Formal Analysis, Investigation, Validation, Writing – Original Draft Preparation, Writing – Review & Editing; **Baasiri M:** Formal Analysis, Investigation, Methodology, Writing – Original Draft Preparation; **Atwi K:** Formal Analysis, Investigation, Methodology; **Sowlat MH:** Formal Analysis, Investigation, Validation, Writing – Review & Editing; **Shirmohammadi F:** Investigation, Validation, Writing – Review & Editing; **Shihadeh AL:** Conceptualization, Funding Acquisition, Investigation, Project Administration, Resources, Supervision, Writing – Review & Editing; **Sioutas C:** Conceptualization, Formal Analysis, Funding Acquisition, Investigation, Methodology, Project Administration, Resources, Supervision, Writing – Review & Editing

**Competing interests:** No competing interests were disclosed.

**Grant information:** This study was supported in part by the University of Southern California Viterbi Dean's Ph.D. Fellowship, and by National Institutes of Health research grants [RF1-AG051521-01 and R21-AG050201-01A1].

*The funders had no role in study design, data collection and analysis, decision to publish, or preparation of the manuscript.*

**Copyright:** © 2019 Lovett C *et al.* This is an open access article distributed under the terms of the [Creative Commons Attribution License](#), which permits unrestricted use, distribution, and reproduction in any medium, provided the original work is properly cited. Data associated with the article are available under the terms of the [Creative Commons Zero "No rights reserved" data waiver](#) (CC0 1.0 Public domain dedication).

**How to cite this article:** Lovett C, Baasiri M, Atwi K *et al.* **Comparison of the oxidative potential of primary (POA) and secondary (SOA) organic aerosols derived from  $\alpha$ -pinene and gasoline engine exhaust precursors [version 2; peer review: 2 approved]** F1000Research 2019, 7:1031 <https://doi.org/10.12688/f1000research.15445.2>

**First published:** 09 Jul 2018, 7:1031 <https://doi.org/10.12688/f1000research.15445.1>

**REVISED Amendments from Version 1**

Five revisions were made to the manuscript based on referee Ning Zhi's comments:

1. Text was added to support the assumption that hydroxyl radicals were the major products of H<sub>2</sub>O oxidation in the OFR (response to comment 1)
2. Text was added to clarify experimental conditions during sample collection in the SOA condition (response to comment 2)
3. Text was added to specify details of macrophage cell-line proliferation, harvesting, and preparation for PM treatments (response to comment 4)
4. Text was added to specify details of PM sample preparation and treatment conditions in the macrophage assay (response to comment 5)
5. Text was added to address possible role of PM species water-solubility on cellular oxidative stress response (response to comment 6)

See referee reports

## Introduction

A large fraction of ambient particulate matter (PM) in the urban atmosphere consists of a mixture of primary organic aerosols (POA), derived from anthropogenic and biogenic PM sources, as well as secondary organic aerosols (SOA) produced during the photo-oxidation of both types of POA (Baltensperger *et al.*, 2005; Després *et al.*, 2012). Urban PM can consist of up to 90% SOA, the majority originating from primary biogenic aerosols, including the monoterpene  $\alpha$ -pinene, one of the largest components of primary biogenic PM worldwide (Hallquist *et al.*, 2009; Seinfeld & Pankow, 2003).

Several human health problems linked to ambient PM, including asthma, cardiovascular disease, and heart failure (Delfino *et al.*, 2005; Dominici *et al.*, 2006; Kim *et al.*, 2013; Shah *et al.*, 2013), are mediated largely by the cellular inflammatory response, including reactive oxygen species (ROS) formation (Li *et al.*, 2003; Ray *et al.*, 2012). Research investigating PM health effects has mostly focused on primary emissions, while studies of secondary PM effects are not as common. Some studies,

however, report that both anthropogenic (Decesari *et al.*, 2017; Saffari *et al.*, 2015; Verma *et al.*, 2014; Verma *et al.*, 2015a; Verma *et al.*, 2015b) and biogenic (Baltensperger *et al.*, 2008; Gaschen *et al.*, 2010; Rohr, 2013) SOA elicit greater adverse health effects than POA precursors.

In this study, we investigate the effects of photochemical oxidation on the oxidative potential of biogenic and anthropogenic PM. Samples of each PM type were collected before and after photochemical aging within a laboratory reaction chamber equipped with an ultraviolet lamp. The *in vitro* alveolar macrophage (AM) assay was used to quantify PM oxidative potential (Landreman *et al.*, 2008; Li *et al.*, 2008; Shafer *et al.*, 2010).

## Methods

### Sampling methods

Photochemical oxidation of primary emissions occurred within a 64-liter stainless steel oxidation flow reactor (OFR) equipped with a single UV lamp (BHK Analamp, Model No. 82-9304-03) emitting radiation at 185 and 254 nm. Upstream of the PM sources, inlet air first passed through an activated carbon denuder and high-efficiency particulate air (HEPA) filter to remove all particles. Within the OFR, a warm, humid environment (22°C/60% RH) was maintained, allowing H<sub>2</sub>O to act as a source of hydroxyl radicals in the UV-catalyzed oxidation reactions, which resulted in SOA formation. While the production of superoxide radicals is possible, the major products of H<sub>2</sub>O oxidation generated in this type of OFR are hydroxyl radicals, especially at less than 80% relative humidity (Seinfeld & Pandis, 2016; Kamens *et al.*, 2011; Jang *et al.*, 2002).

The biogenic sampling setup is depicted in Figure 1. Particle-free inlet air was introduced at a flow rate of 25 lpm. 0.5 lpm of this incoming air stream was diverted into a 250 ml Büchner flask containing a 15-ml glass vial of pure, reagent grade  $\alpha$ -pinene. Three small holes in the vial cap allowed for diffusion of  $\alpha$ -pinene vapors into the flask. The remaining 24.5 lpm flow of particle-free air proceeded through a humidifier (heated flask containing distilled water) and into the reactor, where it mixed with the  $\alpha$ -pinene vapors, resulting in a dilution ratio of 50:1.

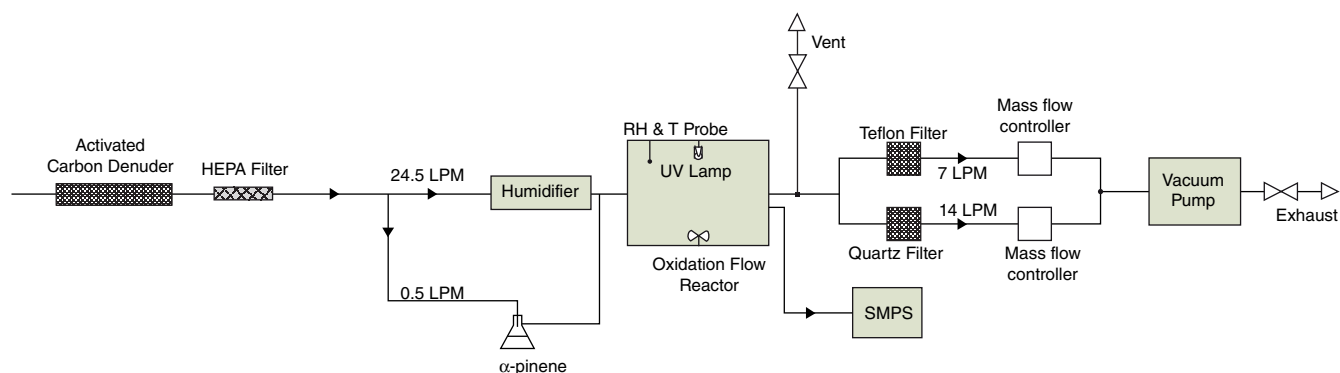

**Figure 1.** Biogenic ( $\alpha$ -pinene) particulate matter (PM) sampling setup.

The anthropogenic sampling setup is depicted in [Figure 2](#). Exhaust from a four-stroke single cylinder gasoline generator (Honda SHX1000, 49cc displacement, 8.0:1 compression ratio, operating at 3000 RPM) was drawn through a rotating disk dilutor (RDD; Testo Engineering, MD19-3E) operating at a dilution ratio of 50:1. 5 lpm of the diluted engine exhaust was diverted into the reaction chamber, where it mixed with 20 lpm of humidified, particle-free air, resulting in a total dilution ratio of 250:1.

Particles were collected downstream of the reaction chamber on Teflon and quartz filters. In the POA condition, PM was collected as the  $\alpha$ -pinene or engine emissions passed through a dark OFR. In the SOA condition, the aerosol stream was sampled while the UV lamp inside the reactor was on. During this condition, the sample stream was diverted for the first 90 minutes to ensure that the reactor was operating under steady-state conditions while samples were collected.

### Filter conditioning

Prior to sampling, quartz filters were baked in a furnace oven at 500°C for 5 hours. Teflon filters were conditioned for 24 hours in a controlled environment (23°C and 46% relative humidity) before weighing. Teflon filters were weighed before and after sampling to determine the mass collected with an MT5 Microbalance (Mettler-Toledo Inc., Columbus, OH, USA). Mass collected on quartz filters was calculated based on the aerosol concentration (from Teflon filters) and sampling flow rate. After sampling, all filters were placed in petri dishes lined with baked aluminum foil, sealed with Teflon tape, and stored in a refrigerated environment until analysis.

### Laboratory analyses

Quartz filters were analyzed for elemental carbon (EC) and organic carbon (OC) content by the National Institute for Occupational Safety and Health (NIOSH) Thermal Optical Transmission (TOT) Method 5040, using a flame ionization detector (FID) to quantify evolved carbon as  $\text{CH}_4$  (Birch & Cary, 1996; Peterson & Richards, 2002).

Each Teflon filter (PM sample or blank) was divided into two sections, one for the macrophage assay and one for chemical

analysis. The filter halves used for the cell assay underwent sonication in 900  $\mu\text{L}$  of purified water for approximately 16 hours at room temperature to extract the water-soluble components. These filters were then removed from the aqueous extracts, and 10x concentrated salts-glucose medium (SGM) was added to create buffered PM extract solutions for use in the PM treatments.

The alveolar macrophage (AM) *in vitro* assay was used to determine the oxidative potential of the Teflon filter PM samples. Alveolar macrophages obtained from the American Type Culture Collection (cell line NR8383, RRID: CVCL\_4396) were maintained in Ham's F12 medium (#11765-047, ThermoFisher, Waltham, MA, USA) supplemented with 2mM L-glutamine (GlutaMAX; #31765-035, ThermoFisher, Waltham, MA, USA), 1.176 g/L sodium bicarbonate, and 15% heat inactivated fetal bovine serum (FBS; #45000-734, VWR, Radnor, PA, USA). Cells were cultured in flasks and kept in an incubator at 37°C/5%  $\text{CO}_2$ . Non-adherent cells were transferred to new flasks weekly. A floating cell concentration of approximately  $4 \times 10^5$  cells/mL media was maintained.

In preparation for PM exposures, the non-adherent fraction of macrophage cells was harvested from flasks and concentrated by centrifugation (750 RPM) for 5 minutes. The culture medium was removed, and the cell suspension was diluted to a concentration of 1,000 cells/ $\mu\text{L}$ . 100  $\mu\text{L}$  aliquots of these suspended cells were then pipetted into each well of 96-well plates (100,000 cells/well) and incubated at 37°C/5%  $\text{CO}_2$  for 2 hours. Following the 2-hour incubation period, nearly all macrophages were adhered to each well bottom. During PM treatments, supernatant media was aspirated and replaced with 100  $\mu\text{L}$  of sample extract or blank control solution in each well.

The macrophage cells were exposed to each type of PM sample for 2.5 hours, using 2,7-dichlorodihydrofluorescein diacetate (DCFH-DA) as a fluorescent probe to quantify the cellular formation of oxidative species. The non-fluorescent DCFH-DA acts by entering the cell, where it is de-acetylated by cellular enzymes to yield 2,7-dichlorodihydrofluorescein (DCFH), also non-fluorescent. DCFH is then oxidized by reactive species, generated during the cellular

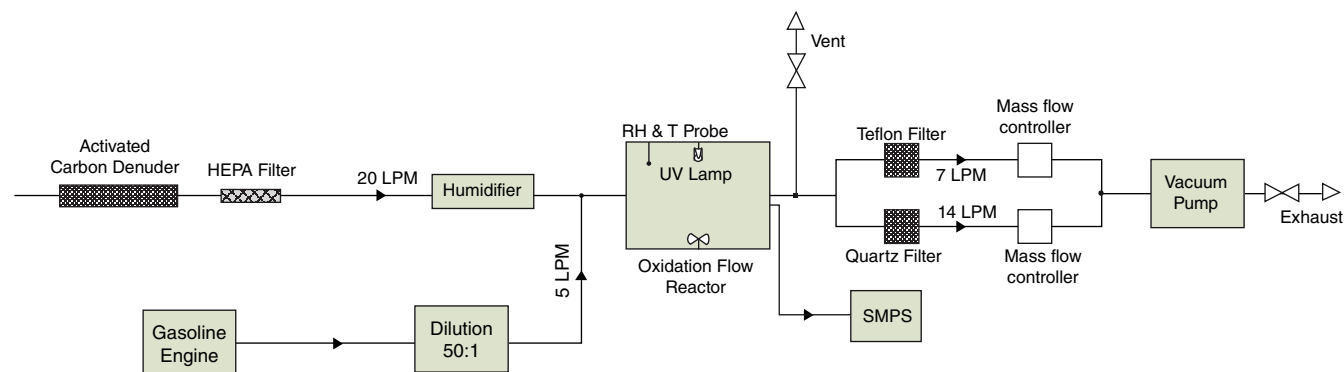

**Figure 2.** Anthropogenic (gasoline engine exhaust) particulate matter (PM) sampling setup.

oxidative stress response to PM exposure, to form the highly fluorescent and detectable 2,7-dichlorofluorescein (DCF), which was quantified spectrophotometrically with a CytoFlour II automated fluorescence plate reader (PerSeptive Biosystems, Framingham, MA, USA) Each treatment or control was run in triplicate (3 wells each). Additionally, several untreated and method blank controls were included on each 96-well plate. Zymosan was included as a positive control at a concentration of 0.125 mg-zymosan/mL in a buffered SGM solution. Results are reported as the increase in fluorescence due to sample treatments relative to the fluorescence observed in the untreated control condition (Landreman *et al.*, 2008; Shafer *et al.*, 2010).

## Results

EC/OC results are presented in Figure 3. EC was most abundant in engine POA (0.081  $\mu\text{g-EC}/\mu\text{g-PM}$ ), with no significant amount present in either engine or  $\alpha$ -pinene SOA. Mass fractions of OC were higher than EC in all conditions (engine POA: 0.62  $\mu\text{g-OC}/\mu\text{g-PM}$ , engine SOA: 0.54  $\mu\text{g-OC}/\mu\text{g-PM}$ ,  $\alpha$ -pinene SOA: 0.54  $\mu\text{g-OC}/\mu\text{g-PM}$ ). Figure 4 presents oxidative potential results on a mass-fraction basis, standardized to Zymosan units ( $\mu\text{g-Zymosan units}/\text{mg-PM}$ ). Mass fraction results reveal how the intrinsic PM toxicity as indexed by oxidative potential changes over time due to photochemical aging. The measured oxidative potential for engine POA was 51.4 ( $\pm 64.3$ )  $\mu\text{g-Zymosan}/\text{mg-PM}$ , and for engine SOA it was 1900 ( $\pm 255$ )  $\mu\text{g-Zymosan}/\text{mg-PM}$ , while for  $\alpha$ -pinene SOA, the result was 1321 ( $\pm 542$ )  $\mu\text{g-Zymosan}/\text{mg-PM}$  (pure  $\alpha$ -pinene was not assayed).

### Dataset 1. Figure 3 EC-OC Raw Data

<http://dx.doi.org/10.5256/f1000research.15445.d209280>

### Dataset 2. Figure 4 ROS Raw Data

<http://dx.doi.org/10.5256/f1000research.15445.d209281>

## Summary and conclusions

The findings of the current reaction chamber study indicate that both anthropogenic and biogenic SOA induce greater cellular oxidative stress than primary engine exhaust. This effect was found to be largest in response to engine exhaust SOA, thus implicating anthropogenic PM as the major contributor to adverse human health effects in urban environments, though the contribution of biogenic SOA can be quite significant in some geographical areas. Atmospheric aging of PM increases its intrinsic oxidative potential many fold, and thus photochemistry in a region that experiences abundant sunshine, long days, and/or stagnation of circulating air due to an inversion layer or some other reason, may increase the toxicity of PM over time.

While the macrophage assay is generally more sensitive to water-soluble components of PM, as compared to non-polar PM species, the large cellular oxidative stress response to SOA, especially anthropogenic SOA, cannot be attributed entirely to hydrophilicity. Biogenic organic compounds are generally

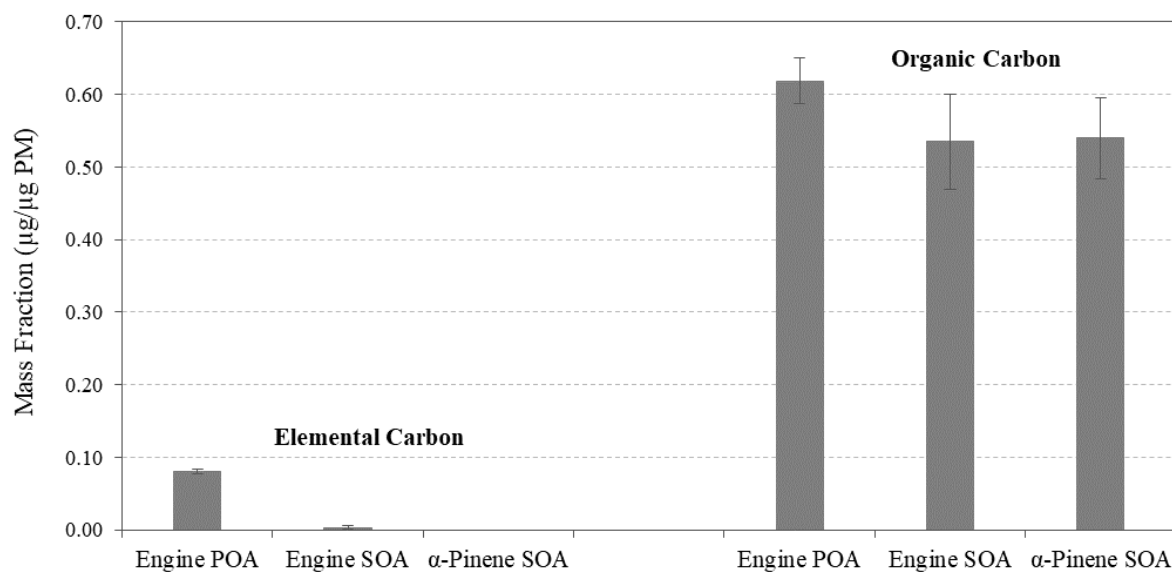

**Figure 3.** Mass fractions of elemental carbon (EC) and organic carbon (OC) in engine primary organic aerosol (POA) and engine &  $\alpha$ -pinene secondary organic aerosols (SOA). Error bars represent laboratory uncertainty values based on contributions of analytical error (standard deviation) and blank subtraction (standard deviation of at least three method blanks).

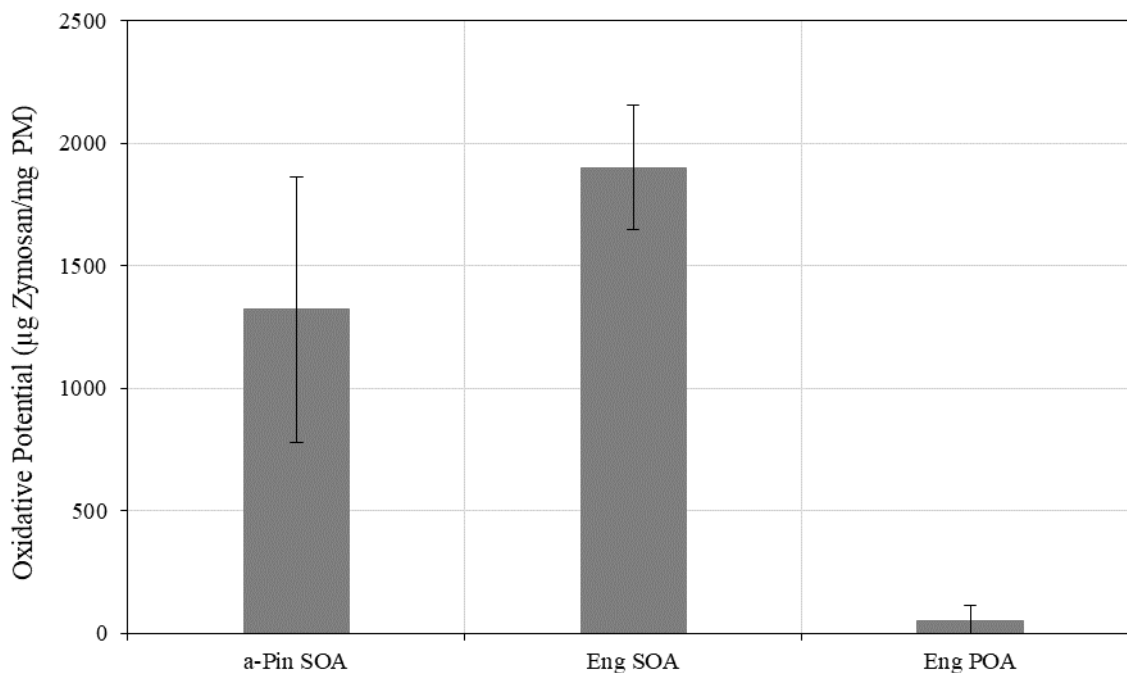

**Figure 4. Mass-fraction based oxidative potential: Engine primary organic aerosol (POA) and engine &  $\alpha$ -pinene secondary organic aerosols (SOA).** Error bars represent laboratory uncertainty values based on contributions of analytical error (standard deviation) and blank subtraction (standard deviation of at least three method blanks).

more hydrophilic than organic products of anthropogenic processes such as combustion, yet greater ROS activity in response to anthropogenic PM was observed. The alveolar macrophage assay is considered an excellent model of inhalation toxicity, and increased ROS formation reliably indexes greater toxicity, whether ultimately due to increased bioavailability of harmful molecules or simply greater quantities of harmful PM species (Landreman *et al.*, 2008). Thus, the results of this study clearly indicate that oxidized PM species, whether of biogenic or anthropogenic origin, are more toxic than primary PM, regardless of water-solubility, with the greatest toxicity resulting from anthropogenic SOA exposures.

#### Data availability

The following raw data sets are provided as comma separated values (.csv) files:

Dataset 1: [Figure 3 EC-OC Raw Data 10.5256/f1000research.15445.d209280](https://doi.org/10.5256/f1000research.15445.d209280) (Lovett *et al.*, 2018a)

Dataset 2: [Figure 4 ROS Raw Data 10.5256/f1000research.15445.d209281](https://doi.org/10.5256/f1000research.15445.d209281) (Lovett *et al.*, 2018b)

#### Grant information

This study was supported in part by the University of Southern California Viterbi Dean's Ph.D. Fellowship, and by National Institutes of Health research grants [RF1-AG051521-01 and R21-AG050201-01A1].

*The funders had no role in study design, data collection and analysis, decision to publish, or preparation of the manuscript.*

#### References

- Baltensperger U, Dommen J, Alfarra MR, *et al.*: **Combined determination of the chemical composition and of health effects of secondary organic aerosols: the POLYSOA project.** *J Aerosol Med Pulm Drug Deliv.* 2008; **21**(1): 145–154.  
[PubMed Abstract](#) | [Publisher Full Text](#)
- Baltensperger U, Kalberer M, Dommen J, *et al.*: **Secondary organic aerosols from anthropogenic and biogenic precursors.** *Faraday Discuss.* 2005; **130**: 265–278; discussion 363–86, 519–24.  
[PubMed Abstract](#) | [Publisher Full Text](#)
- Birch ME, Cary RA: **Elemental carbon-based method for monitoring**

**occupational exposures to particulate diesel exhaust.** *Aerosol Sci Technol.* 1996; **25**(3): 221–241.

[Publisher Full Text](#)

Decesari S, Sowlat MH, Hasheminassab S, *et al.*: **Enhanced toxicity of aerosol in fog conditions in the Po Valley, Italy.** *Atmos Chem Phys.* 2017; **17**(12): 7721–7731.

[Publisher Full Text](#)

Delfino RJ, Sioutas C, Malik S: **Potential role of ultrafine particles in associations between airborne particle mass and cardiovascular health.**



*Environ Health Perspect.* 2005; **113**(8): 934–46.

[PubMed Abstract](#) | [Free Full Text](#)

Després V, Huffman JA, Burrows SM, *et al.*: **Primary biological aerosol particles in the atmosphere: a review.** *Tellus B Chem Phys Meteorol.* 2012; **64**(1): 15598, 1–58.

[Publisher Full Text](#)

Dominici F, Peng RD, Bell ML, *et al.*: **Fine particulate air pollution and hospital admission for cardiovascular and respiratory diseases.** *JAMA.* 2006; **295**(10): 1127–1134.

[PubMed Abstract](#) | [Publisher Full Text](#) | [Free Full Text](#)

Gaschen A, Lang D, Kalberer M, *et al.*: **Cellular responses after exposure of lung cell cultures to secondary organic aerosol particles.** *Environ Sci Technol.* 2010; **44**(4): 1424–1430.

[PubMed Abstract](#) | [Publisher Full Text](#)

Hallquist M, Wenger JC, Baltensperger U, *et al.*: **The formation, properties and impact of secondary organic aerosol: current and emerging issues.** *Atmos Chem Phys.* 2009; **9**(14): 5155–5236.

[Publisher Full Text](#)

Jang M, Czoschke NM, Lee S, *et al.*: **Heterogeneous atmospheric aerosol production by acid-catalyzed particle-phase reactions.** *Science.* 2002; **298**(5594): 814–817.

[PubMed Abstract](#) | [Publisher Full Text](#)

Kamens RM, Zhang H, Chen EH, *et al.*: **Secondary organic aerosol formation from toluene in an atmospheric hydrocarbon mixture: water and particle seed effects.** *Atmos Environ.* 2011; **45**(13): 2324–2334.

[Publisher Full Text](#)

Kim KH, Jahan SA, Kabir E: **A review on human health perspective of air pollution with respect to allergies and asthma.** *Environ Int.* 2013; **59**: 41–52.

[PubMed Abstract](#) | [Publisher Full Text](#)

Landreman AP, Shafer MM, Hemming JC, *et al.*: **A macrophage-based method for the assessment of the reactive oxygen species (ROS) activity of atmospheric particulate matter (PM) and application to routine (daily-24 h) aerosol monitoring studies.** *Aerosol Sci Technol.* 2008; **42**(11): 946–957.

[Publisher Full Text](#)

Li N, Sioutas C, Cho A, *et al.*: **Ultrafine particulate pollutants induce oxidative stress and mitochondrial damage.** *Environ Health Perspect.* 2003; **111**(4): 455–60.

[PubMed Abstract](#) | [Free Full Text](#)

Li N, Xia T, Nel AE: **The role of oxidative stress in ambient particulate matter-induced lung diseases and its implications in the toxicity of engineered nanoparticles.** *Free Radic Biol Med.* 2008; **44**(9): 1689–1699.

[PubMed Abstract](#) | [Publisher Full Text](#) | [Free Full Text](#)

Lovett C, Baasiri M, Atwi K, *et al.*: **Dataset 1 in: Comparison of the oxidative potential of primary (POA) and secondary organic aerosols (SOA) derived from  $\alpha$ -pinene and gasoline engine exhaust precursors.** *F1000Research.* 2018a. <http://www.doi.org/10.5256/f1000research.15445.d209280>

Lovett C, Baasiri M, Atwi K, *et al.*: **Dataset 2 in: Comparison of the oxidative potential of primary (POA) and secondary organic aerosols (SOA) derived**

**from  $\alpha$ -pinene and gasoline engine exhaust precursors.** *F1000Research.* 2018b.

<http://www.doi.org/10.5256/f1000research.15445.d209281>

Peterson MR, Richards MH: **Thermal-optical transmittance analysis for organic, elemental, carbonate, total carbon, and OCX2 in  $PM_{2.5}$  by the EPA/NIOSH method.** In *Proceedings, Symposium on Air Quality Measurement Methods and Technology-2002.* Air & Waste Management Association, Pittsburgh, PA. 2002; 83–1.

[Reference Source](#)

Ray PD, Huang BW, Tsuji Y: **Reactive oxygen species (ROS) homeostasis and redox regulation in cellular signaling.** *Cell Signal.* 2012; **24**(5): 981–990.

[PubMed Abstract](#) | [Publisher Full Text](#) | [Free Full Text](#)

Rohr AC: **The health significance of gas- and particle-phase terpene oxidation products: a review.** *Environ Int.* 2013; **60**: 145–162.

[PubMed Abstract](#) | [Publisher Full Text](#)

Saffari A, Hasheminassab S, Wang D, *et al.*: **Impact of primary and secondary organic sources on the oxidative potential of quasi-ultrafine particles ( $PM_{0.25}$ ) at three contrasting locations in the Los Angeles Basin.** *Atmos Environ.* 2015; **120**: 286–296.

[Publisher Full Text](#)

Seinfeld JH, Pandis SN: **Atmospheric chemistry and physics: from air pollution to climate change.** John Wiley & Sons, Inc., New Jersey, 2016.

[Reference Source](#)

Seinfeld JH, Pankow JF: **Organic atmospheric particulate material.** *Annu Rev Phys Chem.* 2003; **54**(1): 121–140.

[PubMed Abstract](#) | [Publisher Full Text](#)

Shafer MM, Perkins DA, Antkiewicz DS, *et al.*: **Reactive oxygen species activity and chemical speciation of size-fractionated atmospheric particulate matter from Lahore, Pakistan: an important role for transition metals.** *J Environ Monit.* 2010; **12**(3): 704–715.

[PubMed Abstract](#) | [Publisher Full Text](#)

Shah AS, Langrish JP, Nair H, *et al.*: **Global association of air pollution and heart failure: a systematic review and meta-analysis.** *Lancet.* 2013; **382**(9897): 1039–1048.

[PubMed Abstract](#) | [Publisher Full Text](#) | [Free Full Text](#)

Verma V, Fang T, Guo H, *et al.*: **Reactive oxygen species associated with water-soluble  $PM_{2.5}$  in the southeastern United States: spatiotemporal trends and source apportionment.** *Atmos Chem Phys.* 2014; **14**(23): 12915–12930.

[Publisher Full Text](#)

Verma V, Fang T, Xu L, *et al.*: **Organic aerosols associated with the generation of reactive oxygen species (ROS) by water-soluble  $PM_{2.5}$ .** *Environ Sci Technol.* 2015a; **49**(7): 4646–4656.

[PubMed Abstract](#) | [Publisher Full Text](#)

Verma V, Wang Y, El-Afifi R, *et al.*: **Fractionating ambient humic-like substances (HULIS) for their reactive oxygen species activity - Assessing the importance of quinones and atmospheric aging.** *Atmos Environ.* 2015b; **120**: 351–359.

[Publisher Full Text](#)

# Open Peer Review

Current Peer Review Status:  

---

## Version 1

Reviewer Report 25 February 2019

<https://doi.org/10.5256/f1000research.16832.r43635>

© 2019 Ning Z. This is an open access peer review report distributed under the terms of the [Creative Commons Attribution License](#), which permits unrestricted use, distribution, and reproduction in any medium, provided the original work is properly cited.



### Zhi Ning

Division of Environment and Sustainability, Hong Kong University of Science & Technology, Hong Kong, China

#### General Comments:

The authors have investigated the oxidative potential of POA and SOA from two different sources namely alpha-pinene and gasoline engine exhaust. The experimental setup included an UV chamber (oxidation flow reactor), to mimic the sun light's UV rays, to compare primary and secondary organic aerosol-induced radical generation under light and in dark. The comparison could contribute great value to the manuscript if additional parameters as listed below are included in it:

1. Page 3: Right column: Line 4: The authors can address why they have selected only Hydroxyl radicals in the investigations. In some experiments, where UV rays are used to excite the organic aerosols, the elicitation of superoxide radicals is also possible.
2. Page 3: Right column: Lines 28-30: The statement "aerosol stream was sampled while a UV lamp was on, following a 90-minute reaction period." is not clear. Does that mean the whole sample streaming is done for a continuous 90 minutes? Was it the same for the aerosol sampling done in dark OFR?
3. Page 3: Right column: Line 33: The information of the control sample needs to be included here.
4. Page 4: Left column: Line 23: The analysis part has some information missing such as incubation time for cell growth, and are the same generation (life cycle) used for analysis?
5. Page 4: Left column: Line 25: The cell exposure study has some basic information missing - PM dose, route of exposure (directly on filters or on PM extracts), number of times analysed (duplicate or triplicate). Please include for clarity.
6. Page 5: Figure 4: The biogenic organic compounds (for example: the alpha-pinene) are believed to be more hydrophilic compared to engine exhaust organics. Please include a discussion if the water solubility of samples is also driving the difference in oxidative stress.



**Is the work clearly and accurately presented and does it cite the current literature?**

Yes

**Is the study design appropriate and is the work technically sound?**

Yes

**Are sufficient details of methods and analysis provided to allow replication by others?**

Partly

**If applicable, is the statistical analysis and its interpretation appropriate?**

Yes

**Are all the source data underlying the results available to ensure full reproducibility?**

Yes

**Are the conclusions drawn adequately supported by the results?**

Yes

**Competing Interests:** No competing interests were disclosed.

**Reviewer Expertise:** Particle induced cellular oxidative stress, sensor development and application

**I confirm that I have read this submission and believe that I have an appropriate level of expertise to confirm that it is of an acceptable scientific standard.**

Author Response 05 Mar 2019

**Christopher Lovett**, University of Southern California, Los Angeles, USA

Authors' responses to specific comments of Dr. Zhi Ning:

*Comment 1: Page 3: Right column: Line 4: The authors can address why they have selected only Hydroxyl radicals in the investigations. In some experiments, where UV rays are used to excite the organic aerosols, the elicitation of superoxide radicals is also possible.*

**Text Added:**

“While the production of superoxide radicals is possible, the major products of H<sub>2</sub>O oxidation generated in this type of OFR are hydroxyl radicals, especially at less than 80% relative humidity (Seinfeld & Pandis, 2016; Kamens et al., 2011; Jang et al., 2002).”

*Comment 2: Page 3: Right column: Lines 28-30: The statement “aerosol stream was sampled while a UV lamp was on, following a 90-minute reaction period.” is not clear. Does that mean the whole sample streaming is done for a continuous 90 minutes? Was it the same for the aerosol sampling done in dark OFR?*

**Text Revision:**

“In the SOA condition, the aerosol stream was sampled while the UV lamp inside the reactor was on. During this condition, the sample stream was diverted for the first 90 minutes to ensure that the

reactor was operating under steady-state conditions while samples were collected.”

*Comment 3: Page 3: Right column: Line 33: The information of the control sample needs to be included here.*

**Authors' Response:**

The only control samples were the filter blanks submitted to the laboratory for chemical and toxicological analyses as discussed in Section 2.3. Discussion of the control condition utilized in the macrophage assay (untreated cells) is included in the response to Comment 5.

*Comment 4: Page 4: Left column: Line 23: The analysis part has some information missing such as incubation time for cell growth, and are the same generation (life cycle) used for analysis?*

**Text Added:**

“In preparation for PM exposures, the non-adherent fraction of macrophage cells was harvested from flasks and concentrated by centrifugation (750 RPM) for 5 minutes. The culture medium was removed, and the cell suspension was diluted to a concentration of 1,000 cells/ $\mu$ L. 100  $\mu$ L aliquots of these suspended cells were then pipetted into each well of 96-well plates (100,000 cells/well) and incubated at 37°C/5% CO<sub>2</sub> for 2 hours. Following the 2-hour incubation period, nearly all macrophages were adhered to each well bottom. During PM treatments, supernatant media was aspirated and replaced with 100  $\mu$ L of sample extract or blank control solution in each well.”

*Comment 5: Page 4: Left column: Line 25: The cell exposure study has some basic information missing - PM dose, route of exposure (directly on filters or on PM extracts), number of times analysed (duplicate or triplicate). Please include for clarity.*

**Text Added:**

“Each Teflon filter (PM sample or blank) was divided into two sections, one for the macrophage assay and one for chemical analysis. The filter halves used for the cell assay underwent sonication in 900  $\mu$ L of purified water for approximately 16 hours at room temperature to extract the water-soluble components. These filters were then removed from the aqueous extracts, and 10x concentrated salts-glucose medium (SGM) was added to create buffered PM extract solutions for use in the PM treatments.” “Each treatment or control was run in triplicate (3 wells each). Additionally, several untreated and method blank controls were included on each 96-well plate. Zymosan was included as a positive control at a concentration of 0.125 mg-zymosan/mL in a buffered SGM solution. Results are reported as the increase in fluorescence due to sample treatments relative to the fluorescence observed in the untreated control condition.”

*Comment 6: Page 5: Figure 4: The biogenic organic compounds (for example: the alpha-pinene) are believed to be more hydrophilic compared to engine exhaust organics. Please include a discussion if the water solubility of samples is also driving the difference in oxidative stress.*

**Text Added (to Summary and Conclusions):**

“While the macrophage assay is generally more sensitive to water-soluble components of PM, as compared to non-polar PM species, the large cellular oxidative stress response to SOA, especially

anthropogenic SOA, cannot be attributed entirely to hydrophilicity. Biogenic organic compounds are generally more hydrophilic than organic products of anthropogenic processes such as combustion, yet greater ROS activity in response to anthropogenic PM was observed. The alveolar macrophage assay is considered an excellent model of inhalation toxicity, and increased ROS formation reliably indexes greater toxicity, whether ultimately due to increased bioavailability of harmful molecules or simply greater quantities of harmful PM species (Landreman et al., 2008). Thus, the results of this study clearly indicate that oxidized PM species, whether of biogenic or anthropogenic origin, are more toxic than primary PM, regardless of water-solubility, with the greatest toxicity resulting from anthropogenic SOA exposures.”

**Competing Interests:** No competing interests.

Reviewer Report 06 November 2018

<https://doi.org/10.5256/f1000research.16832.r39486>

© 2018 van Drooge B. This is an open access peer review report distributed under the terms of the [Creative Commons Attribution License](#), which permits unrestricted use, distribution, and reproduction in any medium, provided the original work is properly cited.



**Barend L. van Drooge** 

Institute for Environmental Assessment and Water Research (IDÆA-CSIC), Barcelona, Spain

The work of Lovett *et al.* presents interesting data on the possible inflammatory effects of SOA from traffic as well as biogenic (pinene) origin. The method setup is well designed, although the variables, such as conditions of relative humidity and temperature, could have been studied in different values. On the other hand, the results show that the biogenic SOA have similar high inflammatory effect in the test compared to traffic SOA, which is an important fact, and indicates that effects have been observed in real-world data. However, the study could have been more complete and higher quality if the researchers would have made an effort to detect and quantify the molecular chemical compounds that are present in the SOA fractions.

The work is suitable for indexing.

**Is the work clearly and accurately presented and does it cite the current literature?**

Yes

**Is the study design appropriate and is the work technically sound?**

Yes

**Are sufficient details of methods and analysis provided to allow replication by others?**

Yes

**If applicable, is the statistical analysis and its interpretation appropriate?**

Yes

**Are all the source data underlying the results available to ensure full reproducibility?**

Yes

**Are the conclusions drawn adequately supported by the results?**

Yes

**Competing Interests:** No competing interests were disclosed.

**I confirm that I have read this submission and believe that I have an appropriate level of expertise to confirm that it is of an acceptable scientific standard.**

---

The benefits of publishing with F1000Research:

- Your article is published within days, with no editorial bias
- You can publish traditional articles, null/negative results, case reports, data notes and more
- The peer review process is transparent and collaborative
- Your article is indexed in PubMed after passing peer review
- Dedicated customer support at every stage

For pre-submission enquiries, contact [research@f1000.com](mailto:research@f1000.com)

**F1000Research**