

<https://doi.org/10.18321/ectj782>

## Estimation and Mode Selection of Deuterium Flux Supply into Ampoule Device Through Diffusion Filter in Experiments with Pb15.7Li Eutectic at the IVG1.M Reactor

Ye. Tulubayev\*, Yu. Ponkratov, M. Skakov, Yu. Gordienko, Zh. Zaurbekova

Branch Institute of Atomic Energy, National Nuclear Center of the Republic of Kazakhstan,  
10 Krasnoarmeyskaya st, Kurchatov, Kazakhstan

### Article info

*Received:*

04 September 2018

*Received in revised form:*

10 November 2018

*Accepted:*

12 December 2018

*Keywords:*

Pb15.7Li eutectic  
deuterium flux  
diffusion  
solubility  
permeability  
palladium-silver filter

### Abstract

One of the most promising materials to produce tritium in fuel cycle of fusion facilities is the lead-lithium eutectic Pb15.7Li. Tritium will be generated in nuclear reactions in a lithium-containing material under the influence of neutron irradiation. However, nowadays a limited number of studies have been conducted with the eutectic of such a composition (with a lithium content of 15.7%) and consequently, there is a lack of data on mechanisms of tritium generation and release from Pb15.7Li. In this regard, there is an urgent necessity for research of tritium generation and release from Pb15.7Li directly under neutron irradiation conditions. For these studies a differential method will be used, which consists in follows: a controlled flux of spectrally pure deuterium will be continuously fed into the experimental cell with the eutectic sample during the reactor experiment. The regulated flux of deuterium will be fed to the experimental cell with the Pb15.7Li sample using diffusion palladium-silver filter. The article describes the process of determination of deuterium flux supply modes into the experimental cell. The temperature dependences of deuterium penetration through diffusion palladium-silver filter are presented. The coefficients of diffusion, solubility and permeability of deuterium through a palladium-silver filter are estimated and the activation energies of these processes as well as the Arrhenius dependence are presented.

### 1. Introduction

To demonstrate the commercial highlights of thermonuclear power, a project on building a DEMO reactor is being implemented in the world. A lead-lithium eutectic was selected as a functional tritium-generating material for use in the fuel cycle of the new reactor [1]. Currently several concepts of Test Blanket Modules (TBM) are developed:

- a) a helium-cooled lead-lithium blanket (European union) [2];
- b) water-cooled lead-lithium blanket (USA, European Union) [3];
- c) double-circuit lead-lithium blanket (USA) [4].

One of the terms for the successful application of the lithium-lead eutectic in fusion reactor is that tritium breeding should be maximally efficient,

and the amount of it leaks into the environment must not exceed the maximum allowable values.

Thus, there is a need to research the processes of generation and breeding of tritium from lead-lithium in experiments on fission reactors. Currently, there is a limited number of survey works intended for the interaction of hydrogen isotopes with lead-lithium eutectics under the conditions of reactor irradiation [5]. Within these studies, however, it has been found that the breeding of tritium from the eutectic is of complex nature and its breeding is significantly affected by the hydrogen isotopes in a purge gas. To study this finding, the experiments to study generation and segregation of tritium from lead-lithium eutectics at a dynamic mode of supply of deuterium to the irradiation device with a Pb15.7Li eutectic will be performed at the IVG.1M reactor in the near future.

\*Corresponding author. E-mail: [tulubaev@nnc.kz](mailto:tulubaev@nnc.kz)

The experiments above need for implementing adjustable deuterium supply into the irradiation device with a Pb15.7Li eutectic. In turn, to do so it is required by an experimental approach to get temperature dependence of deuterium flux through the palladium-silver filter and to determine the main parameters of the hydrogen permeability using the data obtained.

## 2. Permeation technique

To solve the goals set and determine the parameters of deuterium permeability through the palladium-silver filter, the well-known permeability technique was used [6]. The basic equations describing the mass transfer of hydrogen in metals are the Fick equations. For the one-dimensional case, they are as follows:

$$J(x,t) = -D(t) \frac{dC(x,t)}{dx}; \quad (1)$$

$$\frac{dC(x,t)}{dt} = D(t) \frac{d^2C(x,t)}{dx^2}; \quad (2)$$

where,  $J(x,t)$  is the gas flux through a single surface [ $\text{mol}/(\text{s}\cdot\text{m}^2)$ ],  $C(x,t)$  is the concentration of gas in the material [ $\text{mol}/\text{m}^3$ ].

The Eq. (1) describes the rate of gas penetration through a unit of the surface of the medium. The Eq. (2) defines the hydrogen accumulation at a certain point of the medium as a function of time  $t$ .

This paper recorded the flux  $J(t)$  and the amount of diffused material by mass spectrometry

$$Q(t) = \int_0^t J(t) dt.$$

where,  $J(t)$  is the gas flux,  $Q(t)$  is the amount of diffused material.

Further, the main parameters of hydrogen permeability were calculated using the values obtained by an experimental approach.

### 2.1. Design and conditions of experiments

The design of the filter is a cylindrical sealed vessel made of 12Cr18Ni10Ti stainless steel (analogue AISI 304, 316, with content of C up to 0.12%, Cr – 18%, Ni – 10%, Si – 0.8%), soldered into the palladium-silver tube, 100 mm length and with a diameter of  $2 \times 0.15$  mm. For implementa-

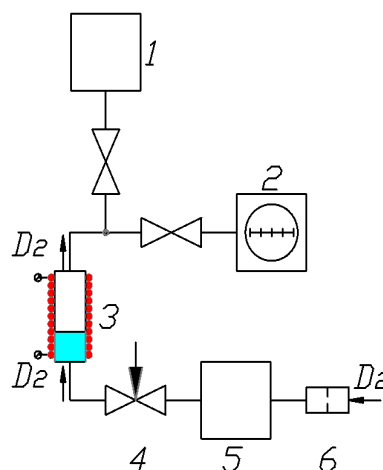

Fig. 1. Design of experiment: 1 – quadrupole mass spectrometer; 2 – turbomolecular pump; 3 – ampoule with lithium eutectic sample; 4 – leak valve; 5 – buffer tank; 6 – palladium-silver filter.

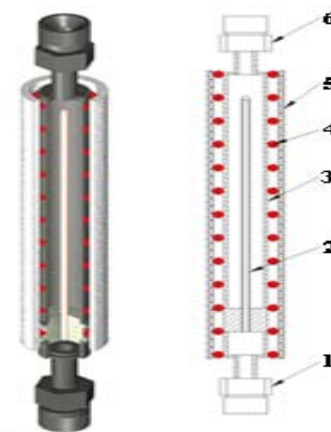

Fig. 2. Palladium-silver filter: 1 – input; 2 – palladium-silver tube; 3 – case; 4 – dipper; 5 – isolation; 6 – output.

tion and control of temperature conditions of the filter in the temperature range from 20 to 450 °C, an ohmic heater is installed on the outer side of the vessel. Design (Fig. 1) and the conditions for experiments to determine the main parameters of deuterium penetration through palladium-silver filter (Fig. 2) depending on the temperature are given below.

Experimental conditions were as follows:

- the residual pressure in the measuring vacuum path –  $10^{-6}$  torr;
- the temperature of the experimental cell of AD – from 25 to 30 °C;
- deuterium pressure supplied to the filter input – 750 torr;
- investigated temperatures range of the filter – from 400 to 160 °C.

## 2.2. Experiments procedure

The experimental procedure for selecting the modes for supplying deuterium fluxes into the irradiation ampoule device was the mass spectrometric recording of deuterium partial pressure on the output of a palladium-silver filter. The parameters to be recorded are temperature of palladium-silver tube and the flux of gas passing through the diffusion filter.

If a deuterium was delivered to the filter at pressure  $P_0$  when measuring with the deuterium permeability rate for filter it turns out that there is a certain time called the delay time, after expiration of which the deuterium is beginning to release from the filter at a constant rate. It is a quasi-steady state of the flux of deuterium that is required to record during these experiments.

The algorithm for the experiments was as follows:

– at the beginning of the experiment, the high-vacuum path of the experimental LIANA bench, along with the ampoule device, was pumped to a pressure

of around  $10^{-6}$  torr. The palladium-silver filter was also pumped from the output by a high-vacuum pump to a pressure of  $10^{-6}$  torr, and from the input side by the forepump to a pressure of  $10^{-4}$  torr;

– the palladium-silver filter was heated to the first set temperature and deuterium was fed to the filter input from the cylinder, with the dripper completely open;

– at the output of the filter, the partial pressure of spectral pure deuterium passed through the experimental cell was recorded using the quadrupole mass spectrometer RGA-100.

– installation of the deuterium flux at a quasi-stationary level (by mass spectrum) is followed by the filter temperature change, and the following measurements were made.

## 3. Results and discussion

The experiments resulted in obtaining time dependences of the change in the deuterium flux on the output of palladium-silver filter and at different temperatures (Fig. 3).

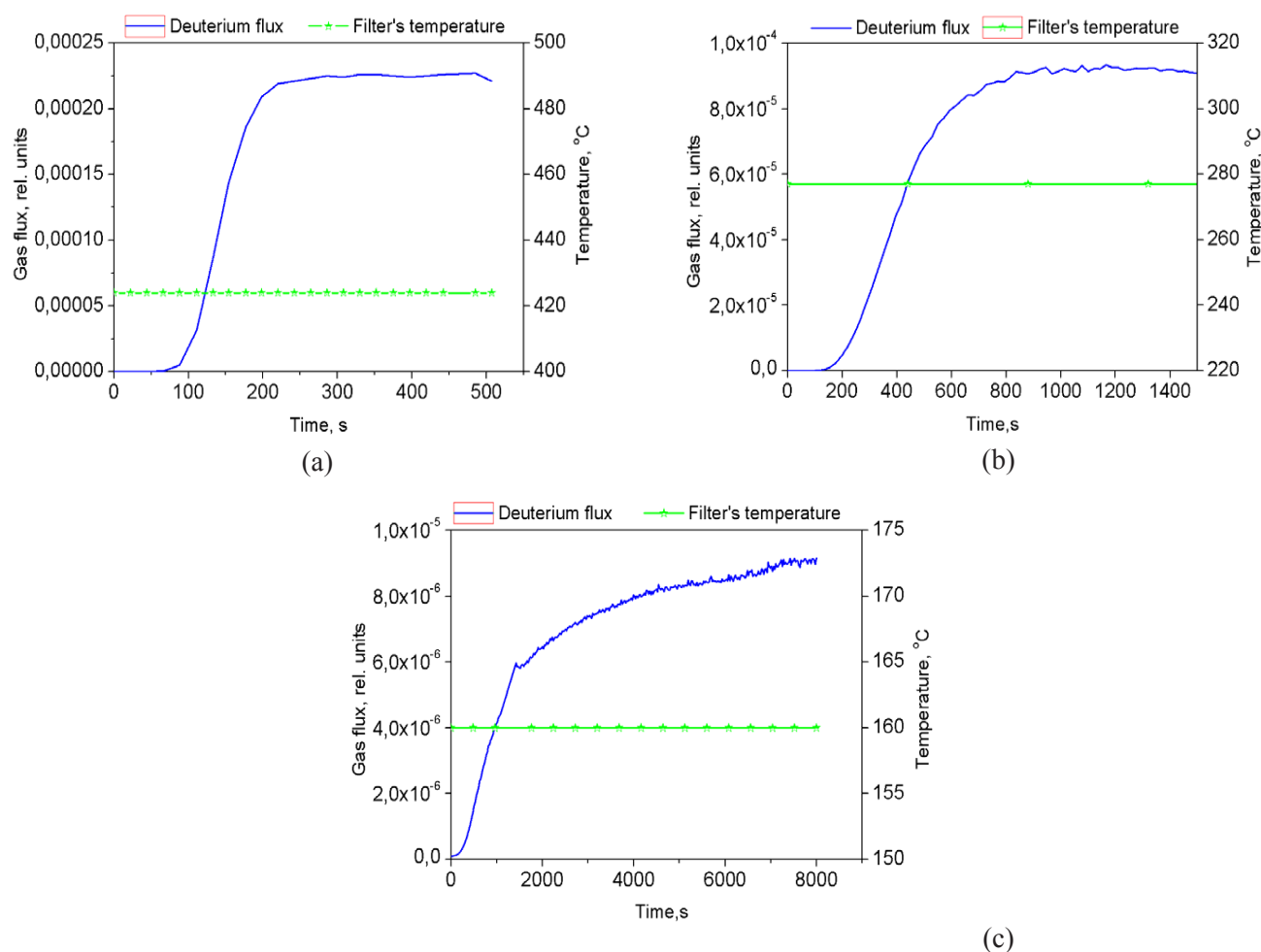

Fig. 3. Time dependences of the change in the deuterium flux on the output of palladium-silver filter at temperature of: (a) – 424 °C; (b) – 278 °C; (c) – 160 °C.

For study the deuterium isotopes penetration through the palladium silver filter, the hydrogen permeability method (so-called dynamic variant, the «breakthrough» mode) was used. The «breakthrough» mode assumed that the initial gas concentration in the material (in our case, a tubular sample of palladium and silver alloy) is zero. At the moment of deuterium supply, the concentration equal to the solubility equilibrium is instantly established on the input side of the sample, and the concentration of deuterium on the output side of the sample at any time remains equal to zero.

The charts above show that as the temperature of the palladium-silver filter increases, the level of the deuterium flux increases proportionally and the rate of flux output to the quasistationary level rises.

The diffusion coefficient  $D_T$  is determined from the experimental dependencies of deuterium flux from the sample for a certain temperatures.

### 3.1. Outcome analysis

Based on the experimental data obtained, the coefficients of diffusion, solubility, and permeability of deuterium for the palladium-silver filter were calculated and the temperature dependences of the variation of these constants were built (Figs. 4 and 5).

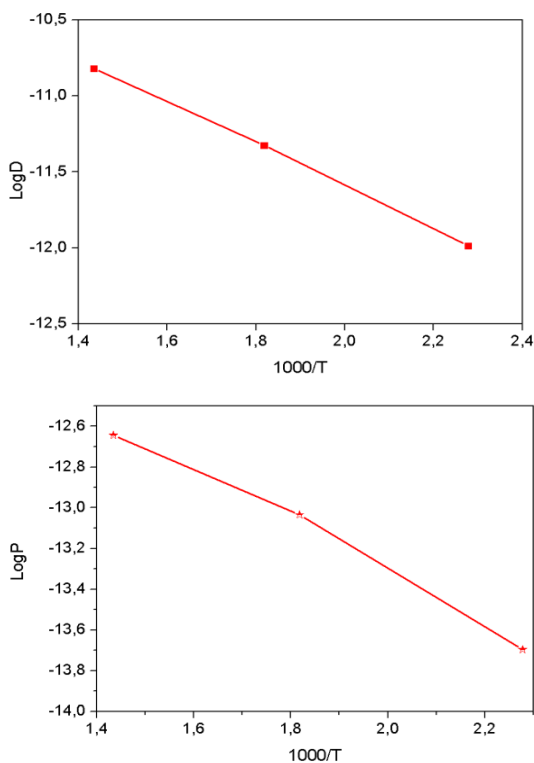

Fig. 4. Temperature dependence of the change in deuterium diffusion and permeability coefficients for a palladium-silver filter.

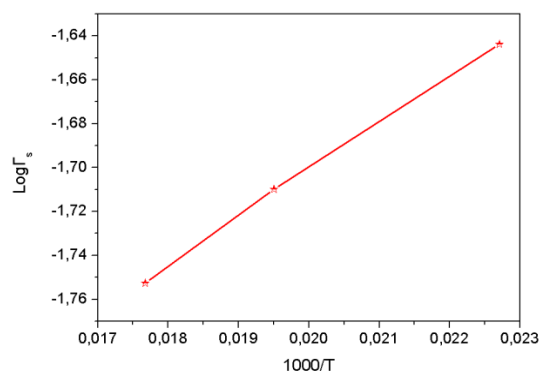

Fig. 5. Temperature dependence of the change in the deuterium solubility coefficient for palladium-silver filter.

Arrhenius dependences of the deuterium diffusion, permeability and solubility coefficients for the palladium-silver filter, which were determined from the charts above (Figs. 4 and 5) are as follows:

$$D = 1 \cdot 10^{-9} \exp \left( \frac{-25 \frac{kJ}{mol}}{RT} \right)$$

$$P = 1.5 \cdot 10^{-11} \exp \left( \frac{-24 \frac{kJ}{mol}}{RT} \right)$$

$$S = 0.01 \cdot \exp \left( \frac{-2.5 \frac{kJ}{mol}}{RT} \right)$$

where,  $D$  is the deuterium diffusion;  $P$  is the permeability coefficients;  $S$  is the solubility coefficients;  $R$  is the gas constant,  $J \cdot mol^{-1} \cdot K^{-1}$ ;  $T$  – temperature, K.

Based on the results obtained, the necessary temperature modes of diffusion palladium-silver filter were determined for implementing a controlled inflow of spectral pure deuterium into the irradiation device at the experiments with the Pb15.7 Li eutectic at the IVG.1M reactor.

Controlled mode of deuterium supply was determined in the temperature range from 150 to 450 °C. Deuterium flux on the output side of filter was from  $2.9 \cdot 10^{-11}$  mol/s to  $2.4 \cdot 10^{-10}$  mol/s.

According to the obtained results we can say that with increasing temperature the speed of deuterium penetration through the palladium-silver tube increases, and the stationary level of deute-



rium flux on the output side of the filter increases. It should be noted that up to 150 °C hydrogen isotopes practically do not penetrate through the filter. In turn, at 400 °C, the maximum deuterium flux on the output side of the filter is established and further temperature increase has little effect on the increase on the stationary level of deuterium flux. This effect is proportional and is described by the temperature dependences of the diffusion coefficient, permeability, and solubility of hydrogen isotopes in the palladium-silver alloy calculated for the palladium-silver filter and given above.

The diffusion of hydrogen isotopes through metal filters are discussed in [7–8]. Article [7] describes the technique of hydrogen permeability experiments and the applicability of this technique. The article considers the permeability of hydrogen isotopes through the following samples: copper bronze CuCrZr, vanadium alloy V4Cr4Ti and stainless steel SS316L. The method of deuterium penetration through SS316IG at the temperature range of 350–550 °C in the conditions of reactor radiation and without radiation is described in [8]. In our case, the deuterium permeates through a tubular sample of palladium-silver alloy (the main element of the hydrogen diffusion filter) in a temperature range of 160–400 °C without the influence of reactor radiation. As can be seen from the publications, the parameters of hydrogen permeability of palladium-silver alloy higher than for other materials. Based on this, the palladium-silver alloy was chosen as the main element for use in the hydrogen diffusion filter.

#### 4. Conclusions

As a result of the conducted experiments the deuterium diffusion, solubility and permeability coefficients were calculated for palladium-silver filter and the Arrhenius dependences were built and energy activation of these processes was determined. Based on the calculations made, the temperature modes of the diffusion filter and the deuterium fluxes were determined which correspond to the following parameters: at filter temperatures of 424 °C, 278 °C and 160 °C, the deuterium fluxes through the experimental cell with a sample of Pb15.7Li will be about  $2.4 \cdot 10^{-10}$ ,  $8.5 \cdot 10^{-11}$  and  $2.9 \cdot 10^{-11}$  mol/s, respectively.

Experimental results can be further used in experiments at fusion reactors, the IVG.1M research reactor and on the tokamak KTM on the study of hydrogen isotopes interaction with structural and

functional materials. Also, the results can be used for mode selection of spectrally pure hydrogen isotopes supply into the working chambers of small laboratory plasma chemical facilities, in which the experiments on controlled thermonuclear fusion are conducted.

#### Acknowledgments

The work was conducted within the research grant financing by the Ministry of Education and Science of the Republic of Kazakhstan No.AP05131677/GF 5.

#### References

- [1]. I. Ricapito, P. Calderoni, Y. Poitevin, A. Aiello, *Fusion Eng. Des.* 89 (2014) 1469–1475. DOI: 10.1016/j.fusengdes.2013.12.028
- [2]. S. Malang, A.R. Raffray, N.B. Morley, *Fusion Eng. Des.* 84 (2009) 2145–2157. DOI: 10.1016/j.fusengdes.2009.02.049
- [3]. P.A. Di Maio, P. Arena, J. Aubert, G. Bongiovi, P. Chiovaro, R. Giammusso, A. Li Puma, A. Tincani, *Fusion Eng. Des.* 98–99 (2015) 1737–1740 DOI: 10.1016/j.fusengdes.2015.03.051
- [4]. M.E. Sawan, B. Smith, E.P. Marriott, P.P.H. Wilson, *Fusion Eng. Des.* 85 (2010) 1027–1032. DOI: 10.1016/j.fusengdes.2010.01.002
- [5]. I. Tazhibayeva, T. Kulsartov, N. Barsukov, Yu.N. Gordienko, Yu. Ponkratov, Zh. Zaurbekova, E. Tulubayev, V. Gnyrya, V. Baklanov, E. Kenzhin, *Fusion Eng. Des.* 89 (2014) 1486–1490. DOI: 10.1016/j.fusengdes.2014.06.002
- [6]. I. Tazhibaeva, A.Kh. Klepikov, O.G. Romanenko, V.P. Shestakov, *Fusion Eng. Des.* 51–52 (2000) 199–205. DOI: 10.1016/S0920-3796(00)00314-8
- [7]. Yu.V. Gordienko, T.V. Kulsartov, Zh.A. Zaurbekova, Yu.V. Ponkratov, V.S. Gnyrya, N.N. Nikitenkov. Application of hydrogen permeation method in reactor experiments on investigation of hydrogen isotope interaction with structural materials. *Izvestija Tomskogo Politehnicheskogo Universiteta: Matematika i mehanika. Fizika* [Bulletin of Tomsk Polytechnic University: Mathematics and mechanics. Physics] 324 (2014) 149–162 (in Russian).
- [8]. T.V. Kulsartov, Y.A. Kenzhin, I. Tazhibayeva, Yu.V. Gordienko, N.I. Barsukov, Yu.V. Ponkratov. Study of reactor irradiation impact on deuterium permeation through stainless steel SS316IG. *Voprosy atomnoj nauki i tehniki. Serija: Termojadernyj sintez* [Problems of atomic science and technology, ser. thermonuclear fusion] 2 (2008) 36–40 (in Russian).