

Proceedings of the 3rd International Conference on Nonlinear Dynamics
ND-KhPI 2010
September 21-24, 2010, Kharkov, Ukraine

**HIGH TEMPERATURE CREEP AND DAMAGE ACCUMULATION IN
CYCLICALLY LOADED AXISYMMETRICAL BODIES OF REVOLUTION**

D.Breslavsky

Yu.Korytko

O.Morachkovsky

National Technical
University 'KhPi', Kharkov,
Ukraine

ABSTRACT

The paper presents the constitutive equations as well as the data of numerical simulation of creep-damage problems of cyclically loaded and heated axisymmetrical structural members. The procedure of constitutive equations deriving is discussed. The experimental and numerical data have been obtained for cyclically heated specimens made from high-quality steel were compared in order to verify the flow rule and damage parameter equation. The problem of creep and damage accumulation in the nipples of the regenerator for catalytic cracking of petroleum was analyzed with consideration of different temperature cycle parameters.

INTRODUCTION

The study of high-temperature long term behaviour of structural members, which calculation schemes correspond to bodies of revolution, needs significant efforts due to necessity of their safety ensuring. One of the important cases of such behaviour includes the joint action of static and cyclic stress and temperature fields. The creep-damage processes in materials and structures, which are working under similar conditions, are often the reason of lifetime limitation.

The creep-damage studies of materials are working under cyclic loading, have been started in 1970th for general type of the cycle, characterizing by introduction of elastic, plastic and creep strain [1]. A great amount of investigations has been done in this direction [1, 2].

From the other hand, the design procedure of major types of structural members demands the absence of plastic strains in initial moments of their work. This fact allows to essentially simplify the general procedure of cyclic creep-damage analysis.

The papers [3, 4] contains the mathematical problem statements and methods of solution for different cases of joint action of static and cyclic stresses, where the assumption of non-varying temperature distribution has been used. The real working conditions of structures which are used in nuclear, power and chemical industry are characterized by temperature variation through their operational cycle.

The aim of presented paper is to discuss the method for creep-damage simulation of bodies of revolution, subjected to cyclic stress loading and cyclic heating. The constitutive equations, which are using for calculations, were obtained by use of asymptotic expansions method and verified by numerous experimental investigations, foremost of S.Taira [5] and G.Guarnieri [6]. The numerical simulation of high-temperature creep-damage in nipple of petroleum cracking's regenerator will be considered as an example.

1. CREEP-DAMAGE ASSESSMENT METHOD. CONSTITUTIVE EQUATIONS

For creep and damage calculations under complex stress state the cyclic creep constitutive equations were suggested in [3]. Combined cyclic loading with constant and cyclically varied stress components were considered and obtained results were experimentally verified.

Creep of metal specimen will be regarded by use of general kinetic structural parameters theory, developed by Yu.N.Rabotnov [7]. Bailey-Norton and Rabotnov-Kachanov equations were

accepted for uniaxial creep-damage law. Widely spread exponential form of temperature dependence was used [1, 7]:

$$\dot{c} = B \frac{(\sigma)^n}{(1-\omega)^k} \exp\left(\frac{-H}{R\varphi}\right); \quad \dot{\omega} = D \frac{(\sigma)^r}{(1-\omega)^l} \exp\left(\frac{-H}{R\varphi}\right); \quad \omega(0) = \omega_0, \quad \omega(t_*) = \omega_*. \quad (1)$$

Here $c(t)$ is irreversible creep strain; $\omega(t)$ is damage parameter; B, D, n, r, k, l are material constants identified by experimental creep and long-term strength material curves; H is the activation energy of creep processes in material; R is the universal gas constant; ω_* is the value of damage parameter in the end of hidden failure at time moment t_* .

Constitutive equations included creep strain rate and damage accumulation dependence from cyclically varied stress were obtained in [3] on the base of two time scale method and asymptotic expansions with averaging on the period in the following form:

$$\dot{c} = B g_n \frac{(\sigma^0)^n}{(1-\omega)^k}, \quad g_n = \int_0^1 \left(1 + \sum_{k=1}^{\infty} M_k \sin(2\pi k \xi)\right)^n d\xi, \quad (2)$$

$$\dot{\omega} = D g_r \frac{(\sigma^0)^r}{(1-\omega)^l}, \quad \omega(0) = \omega_0, \quad \omega(t_*) = \omega_*, \quad g_r = \int_0^1 \left(1 + \sum_{k=1}^{\infty} M_k \sin(2\pi k \xi)\right)^r d\xi. \quad (3)$$

Here g_n, g_r are the coefficient functions of cyclic loading amplitudes.

Let us use the similar approach for obtaining the flow rule for creep strain and kinetic damage law for the case of cyclically varying temperature.

Combined cyclic temperature $\varphi = \varphi^0 + \varphi^1$ will be considered, where φ^0 is a constant temperature and φ^1 is a cyclically varying one. Temperature φ^1 can be presented as a Fourier periodical series, than law for cyclic temperature will have a next form:

$$\varphi = \varphi^0 + \varphi^1 = \varphi^0 \left(1 + \sum_{l=1}^{\infty} M_l^T \sin\left(\frac{2\pi l}{T} t + \beta_l^T\right)\right). \quad (4)$$

The $M_l^T = \frac{\varphi^{al}}{\varphi^0}$ denotes the asymmetry parameter of temperature cycle. It corresponds to the ratio of amplitude temperature to static temperature value, which takes place through the period of cycle.

Incompatibility of main and cyclic periods of combined temperature action allowed to use the methods of asymptotic expansions and averaging on the period of temperature cycle for simulation of cyclic creep and damage accumulation.

Firstly the deformation under constant stress will be considered. Let us use the assumption about the essential exceeding of the general duration of creep process t_* comparing with period value T of temperature φ cyclic component. So why small parameter $\mu = \frac{T}{t_*} \ll 1$ and two time scales were put into consideration. First one will be denoted by t and corresponds to main creep process, second time $\xi = \frac{t}{T}$ will be the time of the temperature cycle, $0 \leq \xi \leq 1$.

Asymptotic solutions can be written in the form of small parameter expansions:

$$c \cong c^0(t) + \mu c^1(\xi), \quad (5)$$

$$\omega \cong \omega^0(t) + \mu \omega^1(\xi), \quad (6)$$

where $c^0(t)$, $\omega^0(t)$, $c^1(\xi)$, $\omega^1(\xi)$ are functions of main creep-damage process in ‘slow’ time scale and periodically process in ‘fast’ time scale ξ .

Taking into account, that creep strain and creep damage parameter depend only on ‘slow’ time and their averaged on the period T_ϕ of ‘fast’ time ξ values are equal to zero:

$$\langle c^1(\xi) \rangle = \int_0^1 c^1(\xi) d\xi \cong 0, \quad \langle \omega^1(\xi) \rangle = \int_0^1 \omega^1(\xi) d\xi \cong 0, \quad (7)$$

only ‘slow’ time remains in expansions (5), (6).

Thus, for cyclic temperature varying, by use of asymptotic expansions technique [5] for equations (1) after averaging on the cycle period T , the following expressions were obtained:

$$\dot{c} = B g_n^T \frac{(\sigma^0)^n}{(1-\omega)^k}, \quad g_n^T = \int_0^1 \exp \left(\frac{-Q}{\varphi^0 \left(1 + \sum_{l=1}^{\infty} M_l^T \sin(2\pi l \xi) \right)} \right) d\xi, \quad (8)$$

$$\dot{\omega} = D g_r^T \frac{(\sigma^0)^r}{(1-\omega)^l}, \quad \omega(0) = \omega_0, \quad \omega(t_*) = \omega_*, \quad g_r^T = \int_0^1 \exp \left(\frac{-\bar{Q}}{\varphi^0 \left(1 + \sum_{l=1}^{\infty} M_l^T \sin(2\pi l \xi) \right)} \right) d\xi, \quad (9)$$

Here g_n^T , g_r^T are the coefficient functions of cyclic heating.

For more complex processes of combined action of cyclic stress and temperature varying the new cyclic thermal creep constitutive equations were obtained:

$$\dot{c} = B g_n g_n^T \frac{(\sigma^0)^n}{(1-\omega)^k}; \quad \dot{\omega} = D g_r g_r^T \frac{(\sigma^0)^r}{(1-\omega)^l}, \quad \omega(0) = \omega_0, \quad \omega(t_*) = \omega_*. \quad (10)$$

Equations (10) were generalized to the case of complex stress state:

$$\dot{c}_{ij} = \frac{3}{2} B \frac{(\sigma_i^0)^{n-1} g_n g_n^T}{(1-\omega)^k} s_{ij}^0, \quad \dot{\omega} = D g_r g_r^T \frac{(\sigma_e^0)^r}{(1-\omega)^l}, \quad \omega(0) = \omega_0, \quad \omega(t_*) = \omega_*. \quad (11)$$

Here c_{ij} denotes the components of creep strain tensor, s_{ij}^0 are the stress deviator components; σ_e^0 and σ_i^0 are equivalent stress defined from definite strength criterion and von Mises equivalent stress respectively.

Obtained constitutive equations allow to perform the mathematical definition of non-linear material straining under joint cyclic loading and heating.

2. VERIFICATION OF CONSTITUTIVE EQUATIONS

Numerical cyclic creep and damage curves, were obtained by use of constitutive equations (10) were verified by use of different experimental data [5, 6]. Cyclic creep-damage behavior of steels, titanium and nickel-based alloys were analyzed. Some comparisons of creep and damage curves were obtained under cyclic heating had been analyzed in [3].

Here let us present only one example of creep and long-term strength curves of the 1H18N9T steel (which is similar to USA S 321 steel), had been obtained numerically in this paper and experimentally by authors of [8].

After experimental curves processing for temperature range 913–1013 K, the values of material constants for constitutive equations (10) were found: $B=1.94 \times 10^7$ MPaⁿ/min, $Q=3.56 \times 10^4$ K, $D=0.118$ MPa^m/min, $\bar{Q}=3.4 \times 10^4$ K, $n=2.35$, $m=5.86$, $k=l=1.12$.

Temperature was varied by triangular law [8] with cycle parameters $\varphi_0 = 913$ K; $\varphi_a = 20 - 100$ K. Minimum cycle temperature were 913K for all cycles, maximum cycle temperature were 1013K for cycle 1, 993K for cycle 2, as well as 973K, 953K and 933 K for 3rd, 4^h and 5th cycles respectively.

Let us analyze the cyclic creep data. For cycles 3, 4 and 5 the creep strain curves were obtained by use equations (10) and compared with experimental data from [8] (scattered in fig. 1). Here curve 1 means to maximum cycle temperature 973K (cycle 3), curve 2 and 3 corresponds to 4th and 5th cycles

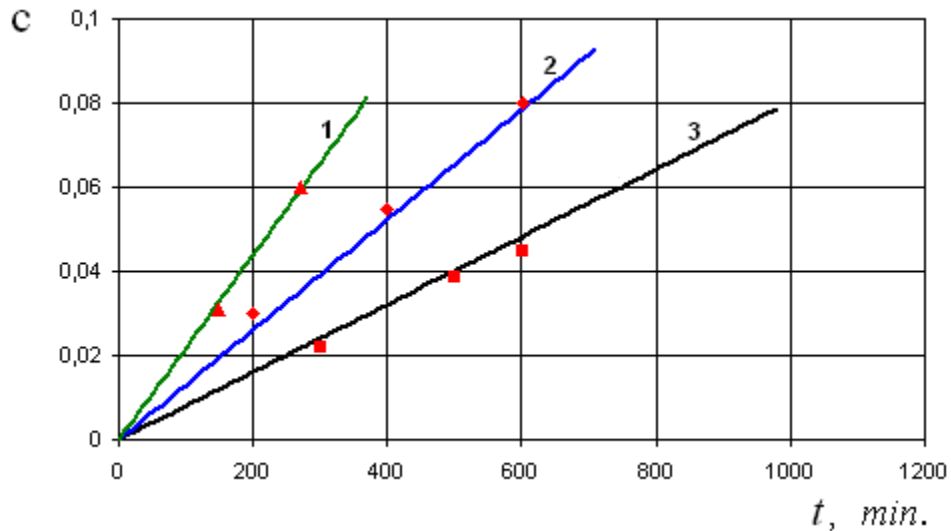

Fig. 1 Cyclic creep curves for steel 1H8N9T

Fig. 2 contains the long-term strength curves for all temperature cycles 1-5. Experimental data are scatter presented.

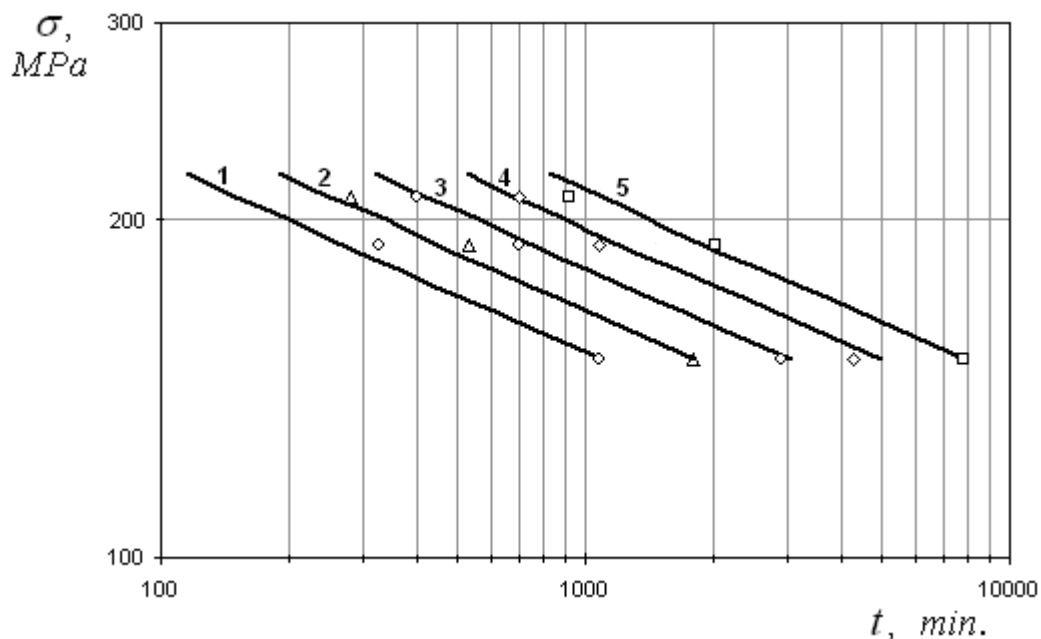

Fig. 2 Long-term strength curves for steel 1H8N9T

Analysis of calculated and experimental data shows that their difference doesn't exceed 8%, what can be regarded as satisfactory result for engineering creep calculations.

3. CYCLIC CREEP DAMAGE IN NIPPLES OF REGENERATOR FOR CATALYTIC CRACKING OF PETROLEUM

Numerical simulation of creep and damage accumulation processes in cyclically loaded and heated structural members were performed by use of combination of FEM and multi-step predictor – corrector time integration scheme. The finite elements with triangular cross-section and linear shape functions were used. The components of strain rate tensors and damage parameter's values are determined by constitutive equations (11).

Below let us consider the practical example of similar numerical simulation were made by use of home-made code, have been designed for 2d creep problems [9].

Cyclic creep and damage accumulation problem were studied for nipples of regenerator of catalytic cracking of petroleum. The calculation scheme of axisymmetrical bodies of revolution was used.

Air diffuser pipe bends, used in petroleum refining industry, equipped with two lines of nipples oriented to opposite sides and directed down with angle 45° to the vertical [10]. Nipple is a branch pipe with a variable section through canal. Expanded canal exit zone allows to reach air flow total widening and its overflow rate lowering. These effects should to prevent catalyst in-flow to the stream periphery, nipple erosion deterioration and should minimize catalyst abrasion (fig. 3).

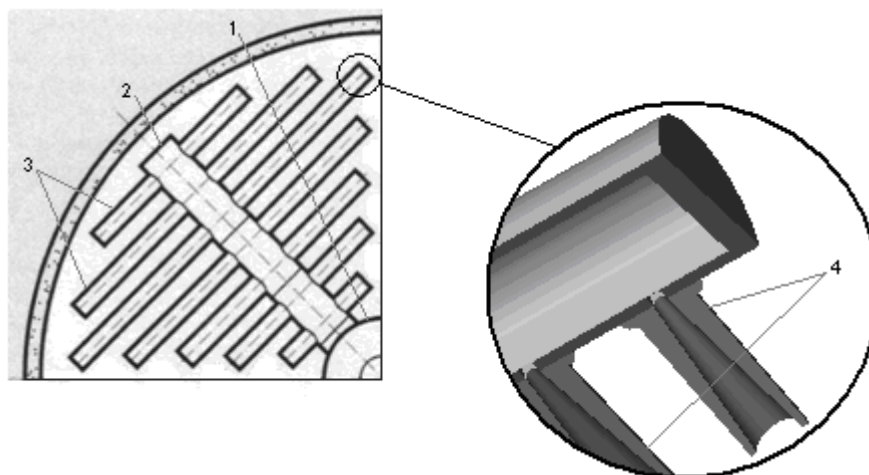

Fig. 3 ¼ part of regenerator air diffuser
1 – central collector; 2 – distribution pipe; 3 – air diffuser pipe bend; 4 - nipple

Table 1 Time of the finishing of hidden damage process in nipples from different temperature zones

		Temperature on the internal nipple surface		
		823K	833K	843K
Temperature varying on the external nipple surface	903K – 943K	143 200 minutes = 3.3 months		
	898K – 948K	121 800 minutes = 2.82 months	228 300 minutes = 5.28 months	
	893K – 953K		184 200 minutes = 4.26 months	
	888K – 958K		148 900 minutes = 3.45 months	280 000 minutes = 6.48 months
	883K – 963K			220 000 minutes = 5.09 months
Results without accounting temperature cyclic character on the external nipple surface, constant temperature T= 923K				
		206 900 minutes = 4.78 months	460 000 minutes = 10.65 months	1.065e ⁶ minutes = 24.65 months

Nipples are made from chromium-nickel steel 1H18N9T, which creep cyclic behavior was analyzed in previous section. Air pressure inside the nipple is 0.294 MPa, catalyst pressure inside the regenerator is 0.25 MPa. Nipple is operated in extreme temperature conditions, induced by considerable difference between temperatures on external and internal surfaces of the nipple.

Temperature singularities of air diffuser device operation were analyzed. Temperature conditions of nipples operation are different and vary depending on distance to the central collector. Complex numerical investigations allowed to define the time of the hidden damage accumulation, which was considered in the paper as a failure of nipples from different temperature zones (table 1).

It was established, that nipples failure happened as a result only of high-temperature cyclic creep-damage mechanisms, which were developed in quite short time of their functioning (often not more than half a year). Finishing of hidden damage process and appearance of macroscopic defects has been occurred on the internal nipple surface in the place of its mounting to the air diffuser pipe bend.

Also, maximal rate values of air stream are typical for pointed places. Macroscopic defects (cracks, splits), which were occurred there owing to cyclic creep, could cause the appearance of the areas of maximal stream turbulence and erosion processes would be significantly intensified.

CONCLUSIONS

New constitutive equations are suitable for numerical calculation of 2d creep-damage problems at the case of joint action of cyclic loading and heating are presented. These equations are involved in numerical method, which is founded on the special asymptotic procedure and the approach of averaging on the period. The method allows to essentially simplify the calculation procedure by way of transition from integration through each cycle to simulation of averaged process of cyclic loading and heating. The procedure of verification and validation involves the comparison between numerical and experimental data for single and complex stress state as well as the numerical and analytical data for problems, which have exact solutions. The cases of different temperature ranges and types of cycles were analyzed. The problem of long-term strength at the conditions of creep and damage accumulation at the cyclically heated nipple of regenerator for catalytic cracking of petroleum is discussed. Analysis of the data of numerical simulation allows to determine the place of macro-crack initiation as well as the fracture time of the nipple. The set of creep-damage problems for nipples are operating in zones with different temperature cycles, were analyzed after numerical simulation. The zones with minimum long-term strength values were found.

REFERENCES

- [1] Lemaitre J., Chaboche J.-L. *Mechanics of solid materials*, University press, Cambridge, 1994.
- [2] Penny R.K., Marriott D.L. *Design for creep*, Chapman and Hall, London, 1995.
- [3] Breslavsky D.V., Morachkovsky O.K., Tatarinova O.A. High-temperature creep and long-term strength of structural elements under cyclic loading *Strength of Materials*, Vol. 40, pp 531-537, 2008.
- [4] Breslavsky D. Simulation of Creep and Damage Effects in Structural Members under Fast Cyclic Load *Zeitschrift fuer Angewandte Mathematik und Mechanik, ZAMM, Applied Mathematics and Mechanics*, Vol. 78, pp. S301-S302, 1998.
- [5] Taira S., Ohtani R. *Theory of high-temperature strength of materials*, Metallurgia Publ., Moscow, 1986. (In Russian)
- [6] Guarnieri G. Characteristics of long-term strength of sheet materials under cyclic loading and temperatures *High-temperature alloys at varying temperatures and stresses*, Gosenergoizdat Publ., Leningrad, pp 65-111, 1960. (In Russian)
- [7] Rabotnov Yu.N. *Creep problems in structural members*, North Holland, Amsterdam, 1969.
- [8] Pysarenko G.S., Mozharovsky N.S., Antipov E.A. *Plasticity and strength of materials under non-stationary loading*, Naukova dumka, Kyiv, 1984. (In Russian).
- [9] Breslavsky D.V., Korytko Yu.N., Lysak P.N. Software for Finite Element simulation of two-dimensional problems of creep theory *Visnyk NTU«KhPI»*, Vol. 38, Kharkiv, pp. 24-29, 2007. (In Russian)
- [10] Solyar B.Z., Glazov L.Sh., Klimtseva E.A. and others Reconstruction of the reactor block for catalytic cracking on the Г-43-107M/1 equipment. First stage. *Chemistry and technology of fuel and motor oil*, Vol. 6, pp.8-13, 2002. (In Russian)