

APPLYING PRECEDENCE RELATIONSHIPS AND CAD/CAM SIMULATION IN TIME-BASED OPTIMIZATION OF PROCESS PLANNING

Dejan Lukić¹, Mijodrag Milošević¹, Jovan Vukman¹, Mića Đurđev¹, Aco Antić¹

¹University of Novi Sad, Faculty of Technical Sciences, Trg Dositeja Obradovića 6, 21000 Novi Sad

Abstract:

Optimization of process planning belongs to the group of combinatorial optimization problems which at the macro and micro level consists of the selection of machining operations, definition of sequences of machining operations and their grouping into processes, selection of manufacturing resources, machining parameters and strategies. The objective function used for evaluating process plans is mostly defined by manufacturing cost, manufacturing time, surface quality and surface accuracy.

The main goal of this research refers to the process planning and optimization of manufacturing time by applying precedence relationships among machining operations, as well as the simulation technique within the CAD/CAM system. The precedence relationships are defined on the basis of dimensional, geometric, technological and economical precedence constraints. Based on these rules, precedence matrices for determining operation sequence for the given shaft part are formed, and afterwards, machining operations are grouped into appropriate processes. For the given rational variants of process plans, a simulation of machining process is performed within the Catia software system. The obtained output is the best variant of process plan for the shaft part on the basis of manufacturing time as the adopted objective function.

ARTICLE HISTORY

Received 26.09.2017.

Accepted 09.11.2017.

Available 15.12.2017.

KEYWORDS

process planning, optimization, manufacturing time, machining operations, machining feature precedence rules, CAD/CAM simulation.

1. INTRODUCTION

Production system will operate well, achieve growth and development only if market requirements are met, that is, if it produces usable, economical, well-designed, environmentally-friendly, competitive and marketable products [1].

Within production systems, a dominant role in meeting market requirements for novel and customized products belongs to processes of design, planning, control and manufacturing. Technological preparation of production as a function of production system represents the basic integrating component of the mentioned processes [2]. The basic task of the technological preparation of production is to study product design and manufacturing capabilities of a production system and according to that provide the best possible manufacturability of product

design and determine the most effective manufacturing methods and techniques for rational utilization of manufacturing resources within the production process [3]. General model of technological preparation of production consisting of six stages is represented in the paper [4]. Fig.1 shows the activity tree of the model of technological preparation of production.

Two main tasks of the technological preparation of production are process planning and optimization of process plans. Process planning consists of conceptual and detailed process planning which is then divided into macro and micro process planning [3-5]. Generally, the detailed process planning is focused on many tasks, such as the selection and design of raw materials, feature recognition and extraction, definition of machining operations and their grouping into process operations, definition of process

operations and their sequences, selection of machining and manufacturing systems, determination of machining allowances and appropriate tolerances, selection of technological bases and appropriate fixtures, selection of tooling, selection of measuring methods and appropriate measuring instruments, selection of machining parameters and strategies, and so on [4,6]. Techno-economic optimization of process plans is concerned with finding the best solution for given conditions that are based on the technological and economical optimization criteria [3,7,8].

In practice, two approaches are usually applied in the macro process planning [4]:

1. The first or traditional approach comes down to the fact that based on the design and technological analysis of product characteristics machining surfaces are defined, then on the basis of experience, types and sequence of process operations are determined first, and types and sequences of machining operations with all the necessary information, such as manufacturing resources and machining parameters are defined afterwards; and,
2. The second approach is based on the recognition and extraction of features for which the possible machining operations with the necessary manufacturing resources and manufacturing parameters are defined, and then the sequence of machining operations are defined and later grouped into appropriate process operations.

The first approach is based on the individual process planning which greatly emphasizes the

influence of a designer, and is significantly faster approach but does not offer great possibilities for optimization. The second approach provides considerably better possibilities for optimization and development of modern generative CAPP systems that are based on the application of feature technologies, methods of artificial intelligence, STEP standards and others [2-4].

The main subject and aim of this research is focused on the process planning and optimization of process plans on the basis of manufacturing time by applying precedence rules and the (CAD/CAM) computer simulation.

The second approach in process planning that is previously described will be applied in this paper. Firstly, manufacturing features will be defined for the given product, and later the possible machining operations, tools and other elements of machining system and process will be selected. Precedence rules among machining operations will be defined on the basis of dimensional, geometric, technological and economical precedences. Based on these rules precedence matrices will be formed from which the selection of variants of operation sequences and their grouping into process operations will be performed. Within these tasks, in addition to the selection of variants of machining operations, the selection of resources and machining parameters will also be done. Computer simulation of machining process of the adopted variants of process plans will be realized within the selected (CAD/CAM) system. Based on the realized simulation the most favorable variant will be selected in terms of manufacturing time as the objective function of optimization.

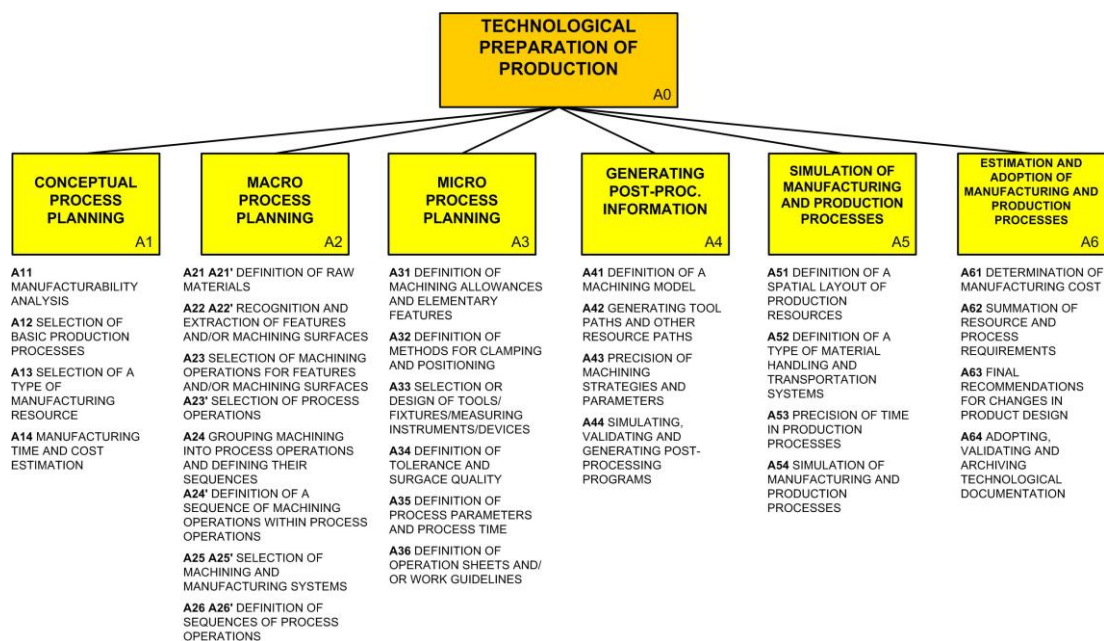

Fig.1. Activity tree of the model of technological preparation of production [4]

2. PRECEDENCE RULES AND COMPUTER SIMULATION IN PROCESS PLANNING AND OPTIMIZATION

2.1 Precedence rules in process planning and optimization

The problem of optimization of process planning, as the subject of this paper, is focused on two tasks within the process planning. The first task is to select and define machining operations for extracted manufacturing features, while the second one represents determination of optimal machining sequence of the given operations. The selection of machining operations is based on the feature geometry, technological requirement in terms of their machining and the determination of an appropriate machine, tool and tool approach direction that will provide good machining of manufacturing features. On the other side, the sequence of machining operations considers the optimal sequence (permutation) of operations which will be used to machine the given features without violating design and technological constraints that are provided on the drawing [9,10].

In terms of the selection of machining operations, machines, tools, fixtures, tool approach directions and determination of operation sequence, many authors define various "flexibilities" that have shown to be crucial for efficient production and the production system itself. According to the [10] these are the following types of flexibilities:

- process flexibility—the possibility of machining the same manufacturing feature using different machining operations or sequences of operations;
- machine flexibility—the possibility of performing the same manufacturing operation on different machines;
- tool flexibility—the possibility of performing the same manufacturing operation using different cutting tools;
- TAD (Tool approach direction) flexibility—the possibility of performing the same machining operation using different tool approach directions, or different types of setup; and,
- sequence flexibility—the possibility of changing the sequence of machining operations that are required for machining the given part.

Precedence relationships among machining operations represent a very significant element of process planning optimization and it directly

depends on these rules whether the process plan will be valid or not. The precedence relationships, or precedence constraints, must be identified in order to verify the selected or randomly generated sequence of machining operations and to determine whether this sequence is feasible or not.

Two main groups of precedence relationships can be found in the literature [11]:

- 1) *Precedence relationships between the realizations of machining features*, which cover: fixture constraints, datum dependencies, parent-child dependencies, avoiding cutter damage, better machining efficiency.
- 2) *Precedence relationships among a set of different types of machining operations*.

For each set of machining operations for machining a feature there are fixed precedence relationships, such as the case when roughing operations come before finishing operations (e.g. drilling comes before reaming, milling comes before grinding etc.).

Precedence relationships among machining operations can be grouped on the basis of technical and economical constraints. According to that fact, the following groups of technical and economical constraints or so called precedences are defined [12]: dimensional precedence, geometric precedence, technological precedence and economical precedence.

Dimensional precedence. Determining precedence among machining operations due to dimensional reasons is related to surface dimensioning and can be defined in the form of the following rule: „Before machining a desired surface a surface related to whom the considered surface is dimensioned is machined first, and priorities have surfaces dimensioned in relation to a datum“.

Geometric precedence. Determining priorities among machining operations due to geometric reasons is related to the requirements in terms of interaction between surfaces and axes, or so called position tolerances. In this case, precedence can be defined in the following form: „Surface related to whom the position tolerance of other surface is defined has the priority in machining“.

Technological precedence. This group of constraints is mostly related to the precedence relationships among operations for machining a feature that do not require more machining operations (e.g. drilling before counter boring, counter boring before reaming, turning before grinding, etc.).

Economical precedence. These constraints are, above all, related to reduction in manufacturing

cost which is achieved by applying more productive or more economical method or a tool instead of less productive or less economical method or a tool.

2.2 Computer simulation in process planning and optimization

A term simulation in technics is most often understood as a technique of development and realization of a model of a real object or a system, with the purpose of studying behavior of that object or system without disturbing its environment. Simulation represents a process that is a copy or a parallel of a real process. Simulation covers a wide range of methods and softwares that mimic a real system. They are mostly realized using computers and appropriate computer programs and simulation systems. A modern simulation can be presented as an experiment conducted on a computer. Basically, a simulation includes three elements: real system, model and a simulation [13].

Modern CAD/CAM software systems that provide a simulation of machining processes are especially significant in process planning which is realized on CNC machining systems. By simulating machining processes, i.e. tool paths, it is also possible to avoid collisions between tools and work-holders, machine components, workpieces, etc. Simulation of machining processes provides the possibility to determine optimal tool type and tool path, then optimal operation type and operation sequence on the basis of manufacturing time [4,7]. Based on the literature analysis in this field, researchers have primarily dealt with the problem of optimization of process plans with the focus on prismatic parts [9,14]. Some authors, such as those in [12,15,16], considered rotationally-symmetric parts in their papers. This paper will consider the application of precedence relationships and the (CAD/CAM) simulation technique in process planning optimization for the

adopted shaft, as a sample of rotationally-symmetric part.

3. PROCESS PLANNING AND OPTIMIZATION FOR A SHAFT PART

3.1 Input data

Basic input data for process planning activities are: part drawing with all the necessary information, production volume in time units/production type and the available manufacturing equipment (machine tools, tools, fixtures, etc.) [4].

Fig.2 shows the 3D model of a shaft made of steel E335 which is used for optimization and whose drawing was taken from the paper [15].

For the given production volume of 1.500 parts per year, a hot rolled bar with $\varnothing 23$ in diameter and 84 mm in length after cutting is used as a rational type of raw material.

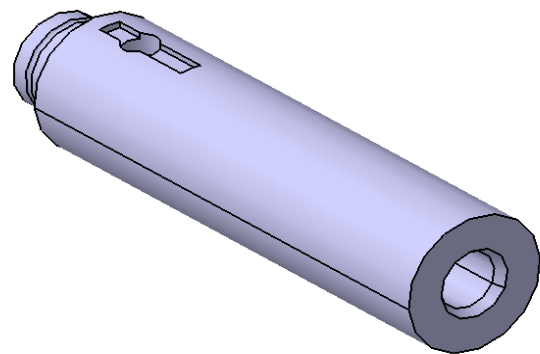

Fig.2. 3D model of a shaft

3.2 Defining machining features and variants of sequences and tools

By analyzing design and technological characteristics of the shaft elementary features were extracted and shown in (Fig.3).

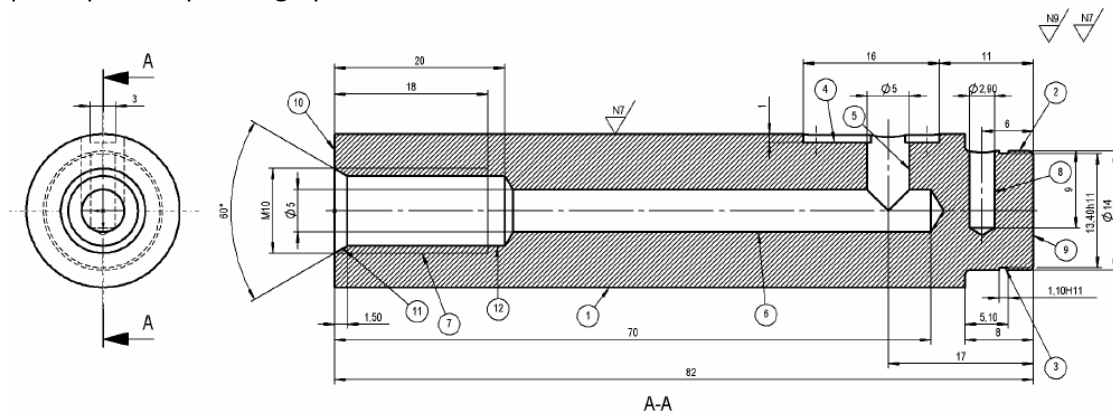

Fig.3. 2D drawing of a shaft with the extracted elementary features

Defined IDs of these features with description of their characteristics are given in the (table 1).

Table 1. Description of the extracted elementary features for the given workpiece - shaft

Feature (F)	Name	Dimensions [mm]	Surface quality
F1	Cylindrical surface	∅20h8 x 74	N7
F2	Cylindrical surface	∅14 x 8	N9
F3	Slot	∅13,4h11x1.1H11	N9
F4	Slot for wedge	3 x 16 x 1	N9
F5	Hole	∅5 x 9	N9
F6	Hole	∅5 x 70	N9
F7	Internal thread	M10x1,5x18	N9
F8	Hole	∅2.9 x 9	N9
F9	Face surface	∅14	N9
F10	Face surface	∅20	N9
F11	Countersink edges	1.5 x 60°	N9
F12	Redrilling/Counterboring	∅ 8.5 x 20	N9

Table 2 gives the recommended machining operations for the given features as well as the appropriate tools.

Table 2. Recommended machining operations and cutting tools for the extracted features

F	Rough machining	Finish machining
F1	Rough turning/ Tool for rough longitudinal turning	Finish turning/ Tool for finish turning
F2	Rough turning / Tool for rough longitudinal turning	-
F3	Parting/ Tool for parting	-
F4	Milling/ End mill cutter ≤ ∅3	-
F5	Drilling/ Center drill	-
	Drilling/ Drill ∅5	-
F6	Drilling/ Center drill	-
	Drilling/ Drill ∅5	-
F7	Threading/ Machining taps M10x1,5	-
F8	Drilling/ Center drill	-
	Drilling/ Drill ∅2,9	-
F9	Rough face turning/ Tool for rough facing turning	-
F10	Rough face turning/ Tool for rough facing turning	-
F11	Countersink/ Conical countersink	-
F12	Redrilling/ Drill ∅8,5 Boring/ Counterboring ∅8,5	-

Cutting tools are chosen from the tool manufacturer catalogue Sandvik Coromant, as well as on the basis of (ISO/SRPS) standards, (table 3).

Based on the specific machining operations and selected tools from the mentioned catalogue and standards, the appropriate tools for performing machining operations as well as the *tool approach directions* (TADs) are defined and shown in (table 4).

According to the precedence rules which include *dimensional, technological, geometric and economical precedence*, the following precedence relationships are defined and shown in (table 5).

Table 3. Defined cutting tools for performing machining operations

Tool ID (T)	Tool name	Tool specification (Sandvik Coromant)
T01	Tool for rough turning	DCLNR/L-16 16 H12 CNMG 12 04 12-PR
T02	Tool for finish turning	DDJNR/L 16 16 H11 DNMX 11 04 04 – WF
T03	Center drill	∅2,5 JUS K.03.061
T04	Drill ∅5	R850-0500-70-A1A
T05	Drill ∅7	R840-0300-70-A0A
T06	Chamfering endmill	R215.94-01500-AC74G
T07	Machining tap M10x1	R217.14C075150AK21N
T08	End mill cutter ∅2	R216.32-02030-AC60P
T09	Drill ∅5	R840-0300-50-A0A
T010	Drill ∅2,9	R840-0290-50-A0B
T011	Parting tool	N123T3-0100-0000-CS
T012	Drill ∅8,5	R840-0850-x0-AyA

Table 4. Defined cutting tool and TAD candidates for the given machining operations

F	Feature name	Tool candidate	TAD candidate
F1	Rough turning right side (OP1)	T01	-z,-x
	Finish turning right side (OP2)	T02	-z,-x
	Rough turning right side (OP3)	T01	-z,-x
	Finish turning right side (OP4)	T02	-z,-x
F2	Rough turning (OP5)	T01	-z,-x
F3	Parting groove (OP6)	T011	+z, -z
F4	Milling groove (OP7)	T08	-z
F5	Center drill (OP8)	T03	-z
	Drilling (OP9)	T09	-z
F6	Center drill(OP8)	T03	-x
	Deep drilling (OP10)	T04	-x
F7	Threading (OP11)	T07	-x
F8	Center drill (OP13)	T03	-z
	Deep drilling (OP14)	T010	-z
F9	Face turning (OP15)	T01	+z, -z
F10	Face turning (OP16)	T01	+z, -z
F11	Conical countersink (OP17)	T06	-x
F12	Redrill (OP18)	T012	-x

Table 5. Precedence relationships among operations

OP	Precedence types			
	Dimensional	Technological	Geometrical	Economical
OP1		OP15		
OP2		OP1, OP15		OP5
OP3		OP16		
OP4		OP3, OP16		
OP5	OP15	OP1		
OP6	OP15	OP1, OP5		
OP7	OP15	OP1, OP2		
OP8	OP15	OP1, OP2, OP7		
OP9	OP15	OP1, OP2, OP7, OP8, OP10, OP11		
OP10		OP16		
OP11	OP16	OP10		
OP12	OP16	OP10, OP11, OP17, OP18		
OP13	OP15	OP1, OP2, OP5		
OP14	OP15	OP1, OP2, OP5, OP13		
OP15				
OP16				
OP17	OP15	OP10, OP11, OP18		
OP18	OP15	OP10, OP11		

Based on the precedence relationships, precedence matrix for the given machining operations is defined and represented in (Fig.4).

OP	1	2	3	4	5	6	7	8	9	10	11	12	13	14	15	16	17	18
1	X														X			
2	X	X				X									X			
3			X													X		
4			X	X												X		
5	X				X										X			
6	X				X	X									X			
7	X	X					X								X	X		
8	X	X					X	X							X	X		
9	X	X					X	X	X	X					X	X		
10										X						X		
11										X	X					X		
12										X	X	X				X	X	X
13	X	X				X									X			
14	X	X			X								X	X				
15																		
16																		
17										X	X				X		X	X
18										X	X				X			

Fig.4. The precedence matrix for machining operations

3.3 Grouping machining operations into process operations/setup

In order to define possible variants of process plans for machining the represented shaft model, it is necessary to group machining operations into appropriate process operations, i.e. setups.

By analyzing the provided machining operations, it can be concluded that the main type of machining operation for both variants is turning in its appropriate setups.

The following text provides variants of machining sequences based on the previously defined precedence matrix and variants of machining operations. Fig.5 and 6 represent two adopted variants of possible machining sequence and their grouping into the appropriate setups. In this case, those variants are called "variant 1" and "variant 2".

OP	1	2	3	4	5	6	7	8	9	10	11	12	13	14	15	16	17	18	1	2	3	4	5	6	7	8	9	10	11	12	13	14	15	16	17	18										
1	X															X				1	OP1																									
2	X	X				X										X				3	2	1	/	/	/	/	/	/	/	/	/	/	/	/	/	OP2										
3			X													X				1	1	1	1	OP3																						
4			X	X												X				2	2	2	2	2	1	OP4																				
5	X															X				2	1	OP5																								
6	X				X											X				3	2	1	/	/	/	/	/	/	/	/	/	/	/	/	/	/	OP6									
7	X	X														X	X			3	2	1	1	1	1	1	1	1	1	1	1	1	1	1	1	OP7										
8	X	X					X									X	X			4	3	2	2	2	2	2	2	2	2	2	2	2	2	2	2	1	OP8									
9	X	X					X	X		X	X					X	X			7	6	5	5	5	5	5	4	3	3	3	3	3	2	1	OP9											
10																X				1	1	1	1	1	1	OP10																				
11											X					X				2	2	2	2	2	1	1	1	OP14																		
12											X	X				X	X	X		5	5	5	5	4	4	4	3	2	1	OP12																
13	X	X														X				4	3	2	2	1	1	1	1	1	1	1	1	1	1	1	1	1	OP13									
14	X	X														X				5	4	3	2	1	1	1	1	1	1	1	1	1	1	1	1	1	1	OP14								
15																				OP15																										
16																				/	/	/	OP16																							
17											X	X				X				4	3	3	3	3	3	3	2	1	OP17																	
18											X	X				X				3	2	2	2	1	1	1	/	OP18																		
																				OP15	OP1	OP5	OP16	OP3	OP4	OP10	OP11	OP18	OP17	OP12	OP2	OP7	OP8	OP9	OP13	OP14	OP6									
																				Process				20/1				20/2				20/3														

Fig.5. Generated sequence of machining operations and their grouping into 3 setups (20/1, 20/2 and 20/3)–variant 1

OP	1	2	3	4	5	6	7	8	9	10	11	12	13	14	15	16	17	18	1	2	3	4	5	6	7	8	9	10	11	12	13	14	15	16	17	18										
1	X															X				1	1	1	OP1																							
2	X	X				X										X				3	3	3	2	1	OP2																					
3			X													X				1	OP3																									
4			X	X												X				2	1	/	/	/	/	/	OP4																			
5	X															X				2	2	2	1	OP5																						
6	X				X											X				3	3	3	2	1	/	OP6																				
7	X	X														X	X			3	3	3	2	1	1	/	/	/	/	/	/	/	/	/	/	OP7										
8	X	X					X									X	X			4	4	4	3	2	2	1	1	1	1	1	1	1	1	1	1	1	OP8									
9	X	X					X	X		X	X					X	X			7	7	7	6	5	5	4	4	4	3	2	2	2	2	2	2	1	OP9									
10																X				1	/	/	/	/	/	/	OP10																			
11											X					X				2	1	1	1	1	1	1	1	1	OP11																	
12											X	X				X	X	X		5	4	4	4	4	4	4	4	3	2	1	OP12															
13	X	X														X				4	4	4	3	2	1	/	/	/	/	/	/	/	/	/	/	/	OP13									
14	X	X														X				5	5	5	4	3	2	1	1	1	1	1	1	1	1	1	1	1	1	OP14								
15																				/	/	OP15																								
16																				OP16																										
17											X	X				X				4	4	4	3	3	3	3	3	2	1	OP17																
18											X	X				X				3	3	3	2	2	2	2	2	2	1	OP18																
																				OP16	OP3	OP5	OP1	OP5	OP2	OP6	OP4	OP10	OP11	OP18	OP17	OP12	OP7	OP8	OP9	OP13	OP14									
																				Process				20/1				20/2				20/3				20/4										

Fig.6. Generated sequence of machining operations and their grouping into 4 setups (20/1, 20/2, 20/3 and 20/4) – variant 2

Table 6 and 7 give a more detailed representation of grouped machining operations for both variants. For the given machining sequence, the tools previously defined in the (table 4) are used.

Table 6. Variant 1 of machining operations

Operation: Turning	
Sub operation	ID operation
20/1	OP15, OP1, OP5
20/2	OP16, OP3, OP4, OP10, OP11, OP18, OP17, OP12
20/3	OP2, OP7, OP8, OP9, OP13, OP14, OP6

Table 7. Variant 2 of machining operations

Operation: Turning	
Sub operation	ID operation
20/1	OP16, OP3
20/2	OP15, OP1, OP5, OP2, OP6
20/3	OP4, OP10, OP11, OP18, OP17, OP12
20/4	OP7, OP8, OP9, OP13, OP14

3.4 Simulation of the adopted variants of process plans within the CAD/CAM software

The Catia software system is adopted as (CAD/CAM) software for modelling and simulation of process plans. The choice of cutting conditions is realized in two ways. The first way is based on the recommendations from the previously mentioned tool catalogue, while the second one is based on the general recommendations from the machining technology manual.

Table 8 shows the simulation times for each machining operation in variant 1 on the basis of the adopted cutting conditions from the mentioned catalog. Table 9 summarizes the obtained results for both variants of process plans and for both ways of choosing cutting conditions.

Table 8. Times for the variant 1 with the recommended cutting conditions by the tool manufacturer

Operation	Machining time [min]	Total time [min]
OP15	00:00:14	00:00:22
OP1, OP5	00:00:34	00:00:44
OP16	00:00:10	00:00:17
OP3	00:00:16	00:00:16
OP4	00:00:08	00:00:13
OP10	00:00:03	00:00:08
OP11	00:02:33	00:02:33
OP18	00:00:06	00:00:07
OP17	00:00:04	00:00:04
OP12	00:00:06	00:00:06
OP2	00:00:05	00:00:21
OP7	00:00:24	00:00:31
OP8	00:00:04	00:00:05
OP9	00:00:07	00:00:10
OP13	00:00:03	00:00:07
OP14	00:00:06	00:00:08
OP6	00:00:03	00:00:05
Σ	5:06 [min]	6:17 [min]

Table 9. Machining time for both variants of process plans and both ways of choosing cutting conditions

Variants TP/ Choose of cutting condition	Machining time [min]	Total time [min]
Var I/ Choose 1	5:06	6:17
Var I/ Choose 2	5:46	8:20
Var II/ Choose 1	5:16	6:50
Var II/Choice 2	5:56	8:40

Based on the manufacturing times for both variants and both ways for choosing cutting conditions obtained from simulation, the conclusion is that the variant 1 with the adopted cutting conditions from the tool catalogue Sandvik Coromant represents a more suitable option.

4. CONCLUSION

The main purpose of technological preparation of production is to provide successful process planning while considering a large number of variants in the shortest possible time.

One of the main problems in process planning is the fact that multi-dimensional planning tasks are defined in a linear form which is particularly important for defining sequences of machining and process operations. In this way, an obtained solution is very far from the optimal one. A number of variants of process plans from the given aspect mostly depend on the availability of machines and fixtures, types of alternative operations for machining each feature, a number of alternative tools for performing machining operations and a number of alternative tool approach directions. Similarly, these variants can also be significant in terms of selecting cutting conditions and machining strategies, applying cooling and lubricating assets and so on.

In this paper, process planning is based on a modern approach that is concerned with the application of feature technologies, definition of machining operations and determination of required information about available machines, tools, fixtures, cutting parameters etc. According to this, the problem of defining feasible operation sequences using precedence relationships is considered in this paper. Also, the focus was on the optimization of obtained feasible sequences using the simulation technique and adopting the manufacturing time as an objective function. Precedence relationships are defined on the basis of dimensional, geometric, technological and economical precedences by analyzing design and technological characteristics of a shaft that is used

as a sample part. Based on these rules, precedence matrices for determining operation sequences are formed, and then these machining operations are grouped into appropriate machining processes, or process operations and the rational variants of process plans obtained at the output. The search process is performed in the Catia software system by simulating machining process for the given variants of process plans.

The defined precedence and time matrices represent the foundation for the optimization of process planning by one of the numerous metaheuristics that provide favorable solutions for complex optimization problems and which would represent a suitable continuation of this research. Likewise, a wide range of alternative machining operations, tools, then machining strategies and cutting conditions can also be considered as the adequate elements for process planning optimization.

Acknowledgements: This work was supported by the project no. TR35025 founded by the Ministry of Education, Science and Technological Development of Republic of Serbia and partially supported by the Provincial Secretariat for Science and Technological Development of The Province of Vojvodina within the project no. 142-451-3556/2016-01.

REFERENCES

- [1] D. Unger, S. Eppinger, Improving product development process design: a method for managing information flows, risks, and iterations, *Journal of Engineering Design*, 22 (10), 2011: pp.689-699.
<https://doi.org/10.1080/09544828.2010.524886>
- [2] X. Xu, L. Wang, S.T. Newman, Computer-Aided Process Planning - A Critical Review of Recent Developments and Future Trends, *International Journal of Computer Integrated Manufacturing*, 24 (1-3), 2011: pp.1-31.
<https://doi.org/10.1080/0951192X.2010.518632>
- [3] D. Lukić, M. Milošević, A. Antić, S. Borojević, M. Ficko, Multi-criteria selection of manufacturing processes in the conceptual process planning, *Advances in Production Engineering and Management*, 12 (2), 2017: pp.151-162.
<https://doi.org/10.14743/apem2017.2.247>
- [4] D. Lukić, Development of a general technological preparation of production model, (Ph.D. Thesis), Faculty of Technical Sciences, University of Novi Sad, 2012.
- [5] A. Rajić, E. Desnica, S. Stojadinović, D. Nedelcu, Development of method for reverse engineering in creation of 3D CAD model of knee implant, *Facta Universitatis Series: Mechanical Engineering*, 11 (1), 2013: pp.45-54.
- [6] S.C. Feng, E.Y. Song, A manufacturing process information model for design and process planning integration, *Journal of Manufacturing Systems*, 22 (1), 2003: pp.1-15.
[https://doi.org/10.1016/S0278-6125\(03\)90001-X](https://doi.org/10.1016/S0278-6125(03)90001-X)
- [7] X. Liu, H. Yi, Z. Ni, Application of ant colony optimization algorithm in process planning optimization, *Journal of Intelligent Manufacturing*, 24 (1), 2013: pp.1-13.
<https://doi.org/10.1007/s10845-010-0407-2>
- [8] V.D. Nguyen, P. Martin, Product design-process selection-process planning integration based on modeling and simulation, *The International Journal of Advanced Manufacturing Technology*, 77 (1-4), 2015: pp.187-201.
<https://doi.org/10.1007/s00170-014-6446-7>
- [9] W. Huang, Y. Hu, L. Cai, An effective hybrid graph and genetic algorithm approach to process planning optimization for prismatic parts, *The International Journal of Advanced Manufacturing Technology*, 62 (9-12), 2012: pp.1219-1232.
<https://doi.org/10.1007/s00170-011-3870-9>
- [10] K. Lian, C. Zhang, X. Shao, Optimization of process planning with various flexibilities using an imperialist competitive algorithm, *The International Journal of Advanced Manufacturing Technology*, 59 (5-8), 2011: pp.815-828.
<https://doi.org/10.1007/s00170-011-3527-8>
- [11] W. Jun, A Kuslak, *Computational Intelligence in Manufacturing Handbook*, CRC Press LLC, USA, 2001.
- [12] G. Halevi, R.D. Weill, *Principles of Process Planning – A Logical Approach*, Chapman & Hall, Inc., 1995.
- [13] S. Živanović, R. Puzović, Wire EDM machining simulations based on STEP-NC program, *Technical Gazette*, 23 (6), 2016: pp.1831-1838.
- [14] M. Milošević, D. Lukić, M. Đurđev, J. Vukman, A. Antić, Genetic Algorithms in Integrated Process Planning and Scheduling – A State of The Art Review, *Proceedings in Manufacturing Systems*, 11 (2), 2016: pp.83-88.

- [15] N. Volarević, P. Ćosić, Improving Process Planning Through Sequencing the Operations, 7th International conference on AMST 05, 2005, Udine, Italy, Vol.485, pp.337-345.
- [16] M. Petrović, M. Mitić, N. Vuković, Z. Miljković, Chaotic particle swarm optimization algorithm for flexible process planning, The International Journal Advanced Manufacturing Technology, 95 (9-12), 2016: pp.2535-2555.
<https://doi.org/10.1007/s00170-015-7991-4>