



Volume 99

2018

p-ISSN: 0209-3324

e-ISSN: 2450-1549

DOI: <https://doi.org/10.20858/sjsutst.2018.99.4>

Journal homepage: <http://sjsutst.polsl.pl>



Article citation information:

Fedin, D., Vinogradov, B. Mechanical system dynamics of tumbling mill drives under steady-state operation. *Scientific Journal of Silesian University of Technology. Series Transport*. 2018, **99**, 43-52. ISSN: 0209-3324. DOI: <https://doi.org/10.20858/sjsutst.2018.99.4>.

Dmytro FEDIN¹, Boris VINOGRADOV²

MECHANICAL SYSTEM DYNAMICS OF TUMBLING MILL DRIVES UNDER STEADY-STATE OPERATION

Summary. In tumbling mill drives, increased dynamic loads may occur in open gearing, which may cause an increase in the vibratory activity of the drive assembly and in dynamic loads in the mechanical drive system as a whole.

Today, no adequate method is available for calculating the dynamic loads in the open gearing of tumbling mills. The article is devoted to the development of a method for dynamic load calculation, which takes into account the parameters of the drive system. The authors have proposed a mathematical model and a technique that allows for the identification of dynamic loads from experimental data and controlling the vibratory activity of the mechanical drive system of a tumbling mill at the design stage.

Keywords: gear mesh; dynamics; drive; tumbling mill

1. INTRODUCTION

Operational experience has shown that significant dynamic loads can occur in the mechanical system of a tumbling mill drive. Certain types of mills, e.g., MRG 5500x7500, exhibit increased vibratory activity of the drive gear assembly, although the vibratory activity

¹ Faculty of Mechanical Engineering, Ukrainian State University of Chemical Technology, Naberezhna Peremohy Str. 40, 49005 Dnipro, Ukraine. Email: mech@udhtu.edu.ua.

² Faculty of Mechanical Engineering, Ukrainian State University of Chemical Technology, Naberezhna Peremohy Str. 40, 49005 Dnipro, Ukraine. Email: mech@udhtu.edu.ua.

of other type mills is much lower. The cause of the dynamic loads has so far not been scientifically explained, which indicates that no reliable method is available to calculate the load capacity of the open gearings of tumbling mills. The purpose of this study is to develop a technique for an identification of dynamic loads in the open gearings of tumbling mills and in the mechanical drive system as a whole, and for predicting vibrational activity in the drive assemblies of tumbling mills.

2. ANALYTICAL REVIEW

2.1. Experimental data

Fig. 1a shows an oscillogram of the shaft torque during the start-up and steady-state operation of the MRG 5500x7500 tumbling mill with a drive equipped with an SDMZ 2-21-64-40 UCH synchronous motor (3,150 kW, gear speed: 150 rpm).

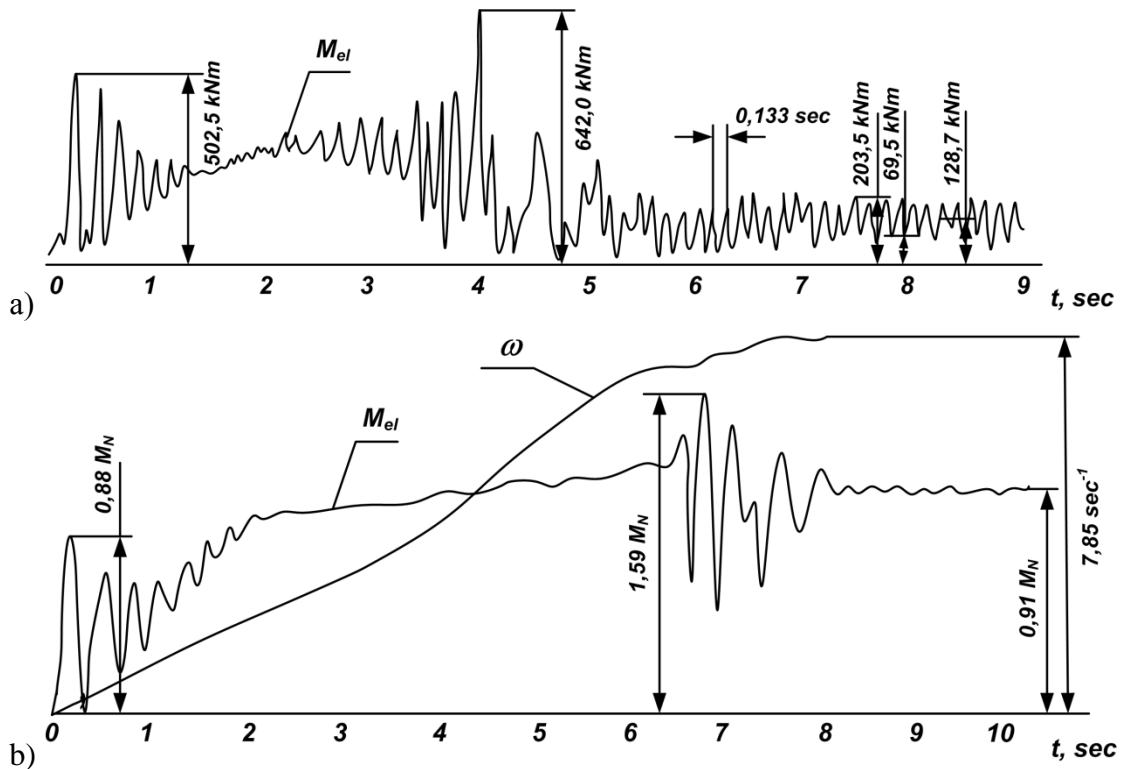

Fig. 1. Oscillogram of the mill start-up: a) MRG 5500x7500;
b) MSHTS 5500x6500; M_{el} - electromagnetic torque; ω - rotational speed; M_N - nominal torque

Fig. 1 shows that torque oscillations occur in the shaft line under steady-state operation, with a triple rotational speed of the drive gear, while the magnitude of torsion vibrations is 1.58 times the static moment. The non-dampening nature of the vibrations indicates that these are forced vibrations. Fig. 1b shows the oscillogram of the shaft torque during the start-up and steady-state operation of the MSHTS 5500x6500 tumbling mill with a drive equipped with a

4,000-kW SDM3-2-24-59-80 U4 synchronous motor (gear speed: 75 rpm). As can be seen in Fig. 1b, the magnitude of the dynamic component of the torque during the period of steady motion is no more than 2% of the nominal torque.

Fig. 2 shows the results for bending stresses in the MRG 5500x7500 mill gear teeth under a static load and a load under steady-state operation. As can be seen in Fig. 2, the dynamic loads in the teeth are generated under steady-state operation. As a result, the tooth stresses are 2.2-4.1 times higher than under a static load.

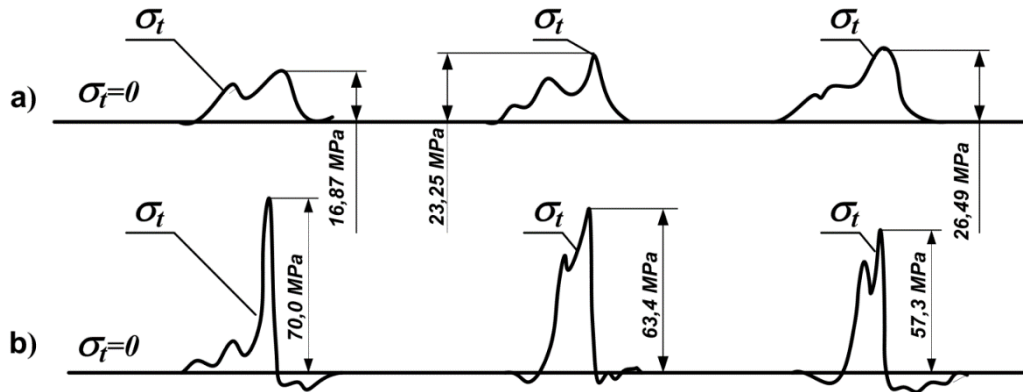

Fig. 2. Bending stress at the tooth root of the pinion of an MRG 5500x7500 tumbling mill: a) static load; b) steady-state operation; σ_t - stress at tooth root

2.2. Calculation techniques

In calculating the load capacity of a gearing, the dynamic loads caused by the impacts from the periodic toothing are taken into account by dynamic factor k_v , which in turn takes into account the influence of inaccuracy in the gear mesh manufacture and installation.

To identify the dynamic processes in the gearing, the standards applied to perform a load capacity analysis for the gearings [1] consider a partial oscillatory system consisting of the reduced mass of the pinion and gear wheel, which are connected flexibly with the stiffness that is equal to the gear mesh stiffness. The calculation of dynamic loads is based on an empirical relationship, which considers the influence of the base pitch deviations and wheel teeth profile modifications on the dynamic load, depending on the rotational speed.

According to ISO 6336-1-1996 (Method B) [2], factor K_{v-B} , which takes into account the internal dynamic loads, is calculated as:

$$K_{v-B} = 1 + N_r K, \tag{1}$$

where N_r is the “resonance ratio” that considers the ratio of the gear rotational speed to the resonance speed of the gearing, and K is the dynamic factor.

The resonance speed of the gear rotation is:

$$n_r = \frac{30}{\pi z_1} \sqrt{\frac{c_{kp}}{J_{np}}}, \tag{2}$$

where c_{kp} is the torsional stiffness of the gearing, N·m, and J_{np} is the equivalent moment of the gearing inertia, $kg \cdot m^2$. Then the resonance ratio is:

$$N_r = \frac{n}{n_r}, \quad (3)$$

where n is the rotational speed of the gear, s^{-1} .

For the pre-resonance range of the gear rotational speeds:

$$N_r \leq N_s \quad (4)$$

where N_s is the lower limit of the resonance range, equal to 0.85, when the specific load is:

$$\frac{F_t K_A}{b} \geq 100 \text{N/mm}. \quad (5)$$

When condition (5) is satisfied, the dynamic factor is calculated according to the empirical relationship:

$$K = c_{v1} B_p + c_{v2} B_f + c_{v3} B_k, \quad (6)$$

where C_{v1} , C_{v2} , C_{v3} , are the non-dimensional empirical factors, when taking into account the deviations in the base pitch and wheel tooth profile, and the influence of cyclic variations in the gearing mesh stiffness, respectively. Meanwhile, B_p , B_f , B_k are the non-dimensional parameters that take into account the effects of the base pitch deviations and wheel tooth profile modifications on the dynamic loads:

$$B_p = \frac{c' f_{pb}}{\frac{F_t K_A}{b}} \quad (7)$$

$$B_f = \frac{c' f_{fa}}{\frac{F_t K_A}{b}}, \quad (8)$$

$$B_k = \left| 1 - \frac{c' C_a}{\frac{F_t K_A}{b}} \right|, \quad (9)$$

where c' is the specific stiffness of a tooth pair, $\text{N/mm} \cdot \mu\text{m}$, f_{pb} , f_{fa} are the effective values of the base pitch and tooth profile deviations, respectively, in μm , and C_a is the tip relief, in μm .

The results from calculating the K_{v-B} factor, which considers the internal dynamic loads, according to the standard [2], are presented in Tab. 1.

Tab. 1

Basic gearing parameters of the MRG 5500x7500 and MSHTH 5500x6500 tumbling mills

Description	Mill model	
	MRG 5500x7500	MSHTH 5500x6500
Engine power N [kW]	3150	4000
Tooth module m_n [mm]	25	25
Number of gear teeth z	25	46
Helix angle β [°]	6	6
Gear speed n [rpm]	150	75
Gear speed (motor) n [rpm]	150	75

Gear ratio	10.1	5.5
Face width b [mm]	900	1000
Accuracy class	8	8
Dynamic factor K_{v-B}	1.1	1.1

It should be noted that a malfunction in the mechanical system can create excitation with a frequency close to one of the base natural frequencies in the system. The resonance vibrations that arise under such conditions result in a load that exceeds the nominal one. In compliance with the standard [3], in such cases, it is necessary to perform vibration analysis of the entire mechanical system, including the connected masses of parts, connection stiffness, the conditions for fixing the parts, and possible sources of excitation. It is necessary to calculate the natural frequencies, the vibration modes and the amplitude-frequency response of the system, which should serve as the basis for the evaluation of the effects on the gearing load capacity [4].

3. RESULTS AND DISCUSSION

3.1. Mathematical model

The open gearing of the tumbling mill, together with the shafts and the connected masses of the mechanical drive, is a single elastic system. When investigating the internal dynamics of a gear set, one can reduce the problem to the consideration of the motion of a mechanical system consisting of a finite number of lumped masses, with elastic connections subject to the kinematic error of the gear wheel.

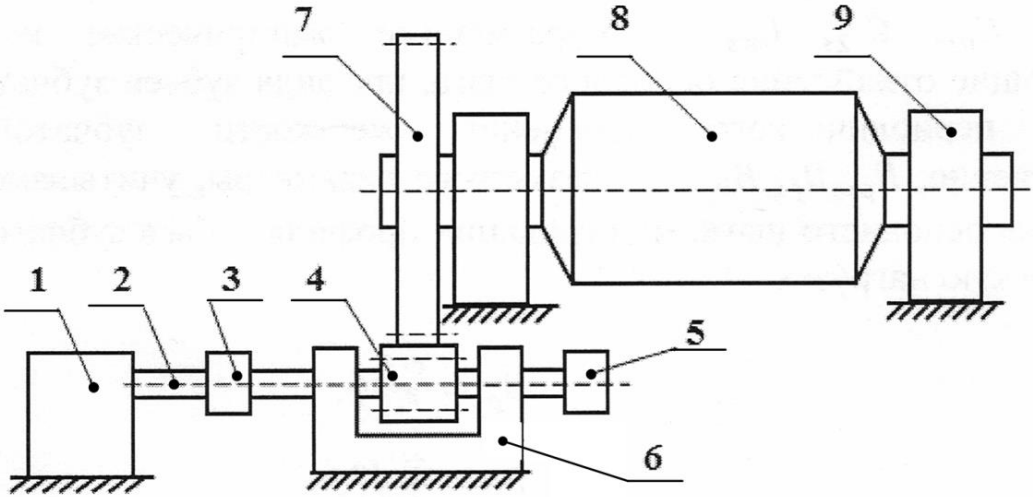

Fig. 3. Kinematic diagram of the mechanical drive system of a tumbling mill

Fig. 3 shows the kinematic diagram of a mechanical system consisting of a synchronous motor (1), a shaft (2) with an elastic coupling (3), a drive gear (4), the pinion of an auxiliary drive (5), the supports of a drive gear (6), and a gear ring (7) rigidly mounted on a mill drum (8) based on the supports (9).

In Expression (1), the factor K takes into account the influence of the kinematic excitation magnitude on the dynamic load in the gear set, and the parameter N_r is the ratio of the force to the natural vibration frequencies. In the proposed model, all these factors are determined by the magnitude of the kinematic excitation, which, for the open gearing of the tumbling mill, can be presented in the form:

$$\Delta(t) = \delta\varphi_H \sin p_p t + \delta\varphi_B \sin p_z t, \tag{12}$$

where: $\delta\varphi_H, \delta\varphi_B$ are the amplitudes of the low-frequency and high-frequency component of the kinematic error, respectively, in rad; $p_p=3\omega_l$ is the circular frequency of the low-frequency component of the excitation, c^{-1} ; and $p_z=\pi n_l z_l/30$ is the circular frequency of the high-frequency component of the excitation, equal to the tooth meshing frequency, c^{-1} .

This approach to the determination of the dynamic loads on the gearing may be laborious as, in this case, the kinematic excitation magnitudes $\delta\varphi_H$ and $\delta\varphi_B$ need to be obtained beforehand. The magnitude of the low-frequency component $\delta\varphi_H$ can be determined by the selection of its values when solving the system of equations (10), such that the magnitude of the forced vibrations in the mechanical system of the gear drive ought to coincide with the value observed experimentally. Knowing the full dynamic load on the gearing and its low-frequency component, the magnitude of the high-frequency excitation $\delta\varphi_B$ can be determined using the superposition principle.

3.2. Calculation technique and results

Tab. 2 presents the main dynamic parameters of the open gearing of the MRG 5500x7500 tumbling mill. Figs. 5- 6 show the results from calculating the dynamic component of the torque in the mechanical system of the gear drive under the effect of the low-frequency and high-frequency components of the kinematic excitation separately.

Tab. 2.
Basic dynamic parameters of the mechanical system of the gear drive in the tumbling mills

Parameter	Value	
	MRG 5500x7500	MSHTS 5500x6500
Equivalent moment of inertia of the rotor I_1 [kg · m ²]	$19.3 \cdot 10^3$	$250.0 \cdot 10^3$
Equivalent moment of inertia of the drive gear I_2 [kg · m ²]	$1.5 \cdot 10^3$	$1.5 \cdot 10^3$
Equivalent mass of the pinion shaft m [kg]	$9.0 \cdot 10^3$	$9.0 \cdot 10^3$
Equivalent moment of inertia of the drum I_3 [kg · m ²]	$19.3 \cdot 10^3$	$250.0 \cdot 10^3$
Torsional stiffness of the electromagnetic field of the motor C_{01} [N · m]	$2.0 \cdot 10^7$	$13.5 \cdot 10^7$
Torsional stiffness of shafting C_{12} [N · m]	$2.2 \cdot 10^7$	$1.8 \cdot 10^7$
Gearing stiffness C_{23} [N · m]	$6.2 \cdot 10^8$	$6.2 \cdot 10^8$
Linear stiffness of the pinion shaft and supports C_2 [N · m]	$35.0 \cdot 10^9$	$35.0 \cdot 10^9$

The analysis of the time dependencies of the torque allows for the determination of the dynamic factor as the ratio of the total torque to its nominal value:

$$K'_v = \frac{M_{\text{полн}}}{M_{\text{ном}}} = 1 + \frac{M_{\text{дин}}}{M_{\text{ном}}}, \quad (13)$$

where $M_{\text{полн}}$ is the total torque acting on the gear set, $M_{\text{ном}}$ is the nominal torque value, and $M_{\text{дин}}$ is the dynamic component of the torque acting on the gear set.

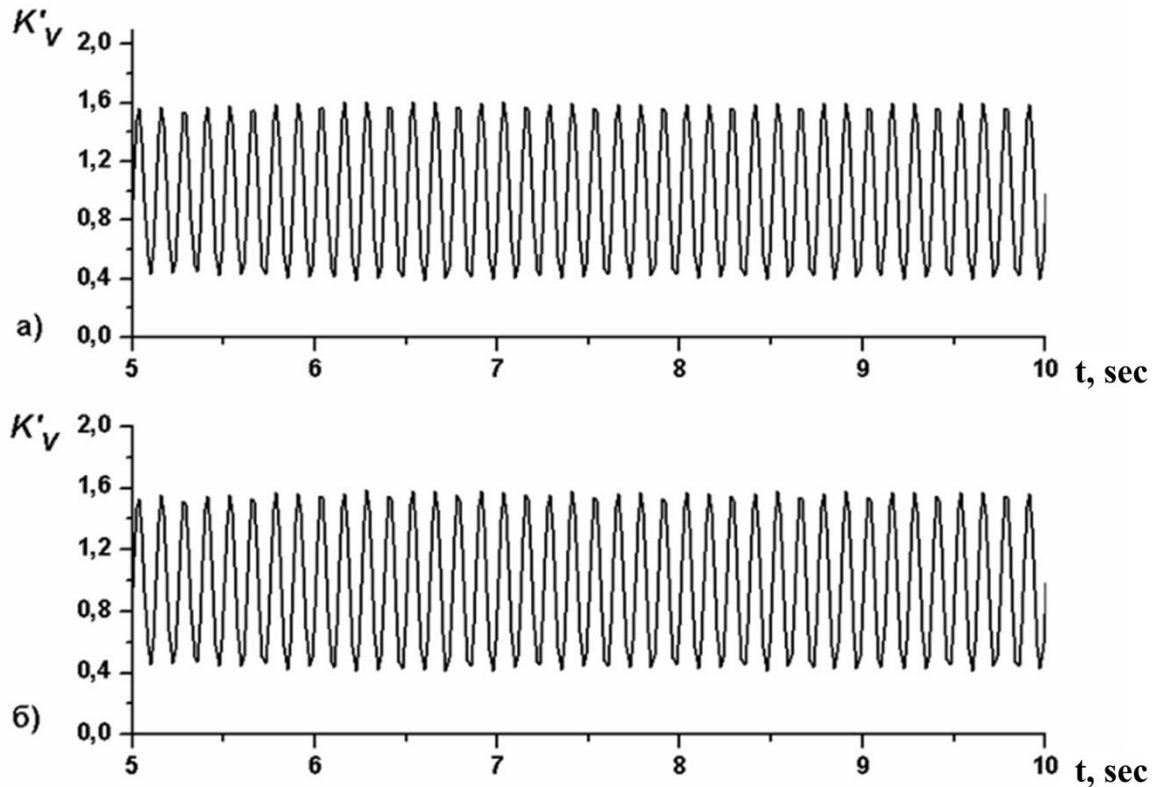

Fig. 5. Calculation results for the forced vibrations in the MRG 5500x7500 tumbling mill under steady-state operation: a) on the shaft; б) in the gear mesh at excitation frequency $pF=3 \cdot 2\omega_1$

The results obtained from the system of equations (10) under the influence of a low-frequency component of the kinematic excitation showed that, due to the low inertia of the gear and other masses of the drive assembly, low-frequency vibrations are transmitted throughout the entire mechanical drive system (Fig. 5). The excitation magnitude, at which the calculated and experimental values of the shaft dynamic factor $K_H=1.58$ coincide, is $r \cdot \delta\varphi_H=0.2$ mm. High-frequency vibrations only significantly affect the dynamics of the gear mesh and drive assembly (Fig. 6).

The total dynamic load in the gearing caused by the low-frequency and high-frequency components of the kinematic excitation takes the value 2.2-4.1, depending on a combination of meshing tooth pairs. Applying the superposition principle, we can write:

$$K_v = K_H K_B, \quad (14)$$

where K_H is the dynamic factor due to the action of a low-frequency component of the kinematic excitation, and K_B is the dynamic factor due to the action of a high-frequency component of the kinematic excitation.

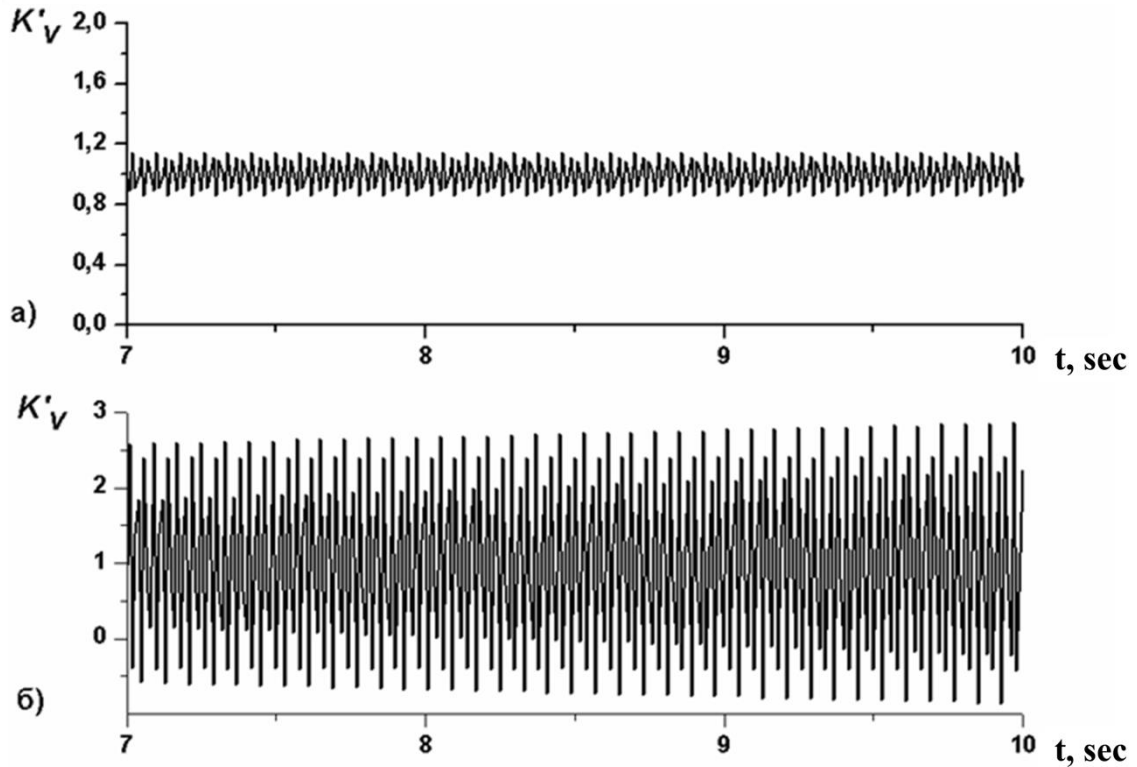

Fig. 6. Calculation results for the forced vibrations in the MGG 5500x7500 mill in the steady-state operating mode: a) on the shaft; b) in the gear mesh at the excitation frequency $p_z = \pi n_1 z_1 / 30$

By knowing the total- and low-frequency components of the kinematic excitation, we obtain:

$$K_B = \frac{K_v}{K_H} = \frac{4,10}{1,58} = 2,59. \tag{15}$$

The solution of the system of equations (10) shows that the calculated and experimental values of the dynamic factor in the gearing $K'_v=2.59$ coincide when the magnitude of excitation $r \cdot \delta \varphi_B = 0.2$ mm (Fig. 6).

4. CONCLUSIONS

Thus, it can be concluded that differential equations of motion used for calculating the dynamics of the mechanical drive system of an open gearing of a tumbling mill under steady-state operation should take into account the kinematic excitation of vibrations in the gearing. In this case, the fundamental harmonics of the excitation spectrum are those with frequencies $3.2 \cdot \omega$ and $z \cdot \omega$, where ω is the angular velocity of the drive gear rotation and z is the number of gear teeth.

In the first approximation, the magnitude of the high-frequency and low-frequency excitation may be equal to 0.2 mm. To further refine the model, it is necessary to experimentally determine the dependence of the kinematic excitation magnitude on tooth wear.

References

1. ISO 1328-1:2013. Cylindrical Gears - ISO System of Accuracy - Part 1: Definitions and Allowable Values of Deviations Relevant to Corresponding Flanks of Gear Teeth. Geneva: International Organization for Standardization.
2. ISO 6336-1:2006. Calculation of Load Capacity of Spur and Helical Gears - Part 1: Basic Principles, Introduction and General Influence Factors. Geneva: International Organization for Standardization.
3. Wojtyła M., W. Jakubiec, W. Płowucha. 2014. "Comparison ISO standards 1328-1: 1995 and 1328-1: 2013". In: *11th International Scientific Conference "Coordinate Measuring Technique" CMT2014*. 2-4 April 2014. Bielsko-Biala, Poland. Available at: https://www.researchgate.net/publication/289719006_Comparison_ISO_standards_1328-11995_and_1328-12013.
4. Jonsta P., I. Vlackova, Z. Jonsta, R. Heide, 2016. "Material analysis of degraded steam turbine rotor". *Komunikacie* 3(78): 78-82.

Received 19.02.2018; accepted in revised form 26.05.2018



Scientific Journal of Silesian University of Technology. Series Transport is licensed under a Creative Commons Attribution 4.0 International License