

Journal of Applied Fluid Mechanics, Vol. 8, No. 2, pp. 197-206, 2015.
Available online at www.jafmonline.net, ISSN 1735-3572, EISSN 1735-3645.
DOI: 10.18869/acadpub.jafm.67.221.20342

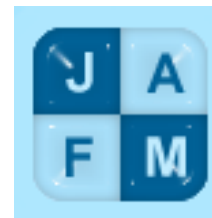

Prediction of Air Flow and Temperature Distribution Inside a Yogurt Cooling Room Using Computational Fluid Dynamics

V. M. Sivakumar, A. Surendhar[†] and T. Kannadasan

Department of Chemical Engineering, Coimbatore Institute of Technology, Coimbatore - 641014, Tamil Nadu, India

[†]Corresponding Author Email: ssfoodtech@gmail.com

(Received April 26, 2013; accepted March 16, 2014)

ABSTRACT

Air flow and heat transfer inside a yogurt cooling room were analysed using Computational Fluid Dynamics. Air flow and heat transfer models were based on 3D, unsteady state, incompressible, Reynolds-averaged Navier-Stokes equations and energy equations. Yogurt cooling room was modelled with the measured geometry using 3D design tool AutoCAD. Yogurt cooling room model was exported into the flow simulation software by specifying properties of inlet air, yogurt, pallet and walls of the room. Packing material was not considered in this study because of less thickness (cup-0.5mm, carton box-1.5mm) and negligible resistance created in the conduction of heat. 3D Computational domain was meshed with hexahedral cells and governing equations were solved using explicit finite volume method. Air flow pattern inside the room and the temperature distribution in the bulk of palletized yogurt were predicted. Through validation, the variation in the temperature distribution and velocity vector from the measured value was found to be 2.0°C (maximum) and 30% respectively. From the simulation and the measured value of the temperature distribution, it was observed that the temperature was non-uniform over the bulk of yogurt. This might be due to refrigeration capacity, air flow pattern, stacking of yogurt or geometry of the room. Required results were achieved by changing the location of the cooling fan.

Keywords: Cooling room; Yogurt; Air flow pattern; Temperature distribution; 3D; Computational Fluid Dynamics.

NOMENCLATURE

P	pressure (Pa)	Y	direction along width of cooling room
c_p	specific heat ($\text{J kg}^{-1} \text{K}^{-1}$)	Z	direction along height of cooling room
E	total energy (J kg^{-1})	T	time (s)
\vec{g}	gravity vector (m s^{-2})		Greek symbol
k	thermal conductivity ($\text{W m}^{-1} \text{K}^{-1}$)	ρ	density (kg m^{-3})
S_M	source term for mass generation ($\text{kg m}^{-1} \text{s}^{-1}$)	ρ_b	bulk density (kg m^{-3})
T	temperature ($^{\circ}\text{C}$)	μ	dynamic viscosity (Pa s)
V	velocity components (m s^{-1})		Abbreviations
U	velocity vector (m s^{-1})	CFD	Computational Fluid Dynamics
S_f^h	enthalpy source term (W m^{-3})	FVM	Finite Volume Method
q	heat flux (W/m^2)	CAD	Computer Aided Design
h	heat transfer coefficient ($\text{W/m}^2\text{K}$)		Operators
X	direction along length of cooling room	∇	Nabla operator (vector differential operator)

1. INTRODUCTION

Yogurt is defined as a coagulated milk product obtained by lactic acid fermentation of milk brought about by *Lactobacillus delbrueckii* subsp. *bulgaricus* and

Streptococcus thermophilus [1, 2] which has been subjected to various forms of heat treatment such as homogenization (60°C), pasteurization ($80\text{-}90^{\circ}\text{C}$) and incubation ($40\text{-}45^{\circ}\text{C}$) for 4-5 hr as shown in Fig.1.

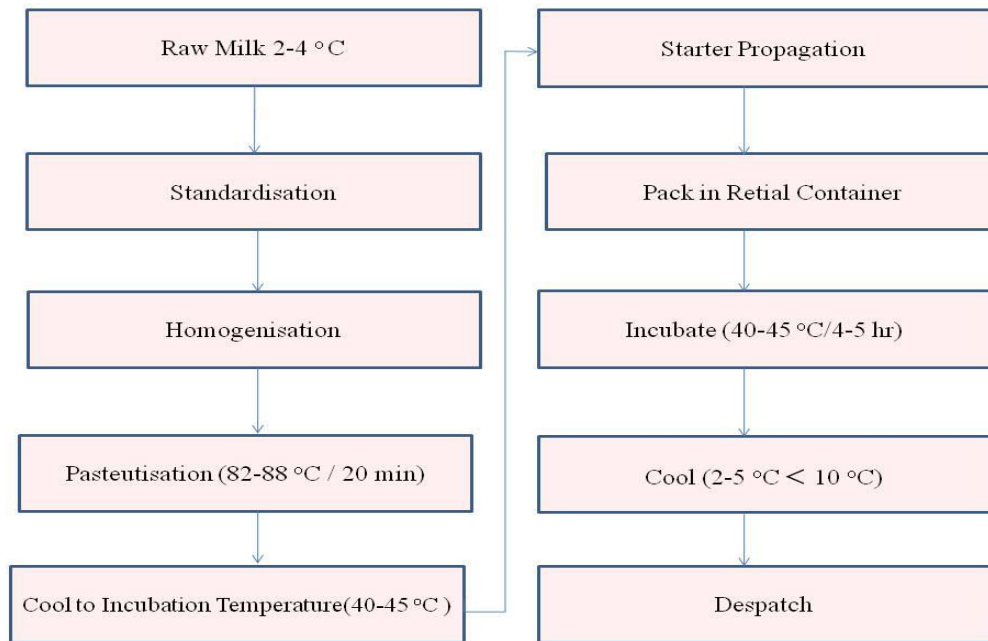

Fig. 1. Flow diagram for manufacture of yogurt

Yogurt has to be kept cold until it reaches the customer. Shelf life of the yogurt remains for 15-21 days in this cold condition. Variation in the temperature of the product affects the texture, viscosity, and syneresis as well as creates a room for food spoilage and food poisoning micro-organisms. Exposure to higher temperatures than the recommended standard increases biochemical reactions such as fat oxidation, hydration of protein constituents and dehydration of exposed yoghurt surface [3]. Chill storage should be between 2°C and 5°C, with no rise above 10°C. Uniform cooling or temperature distribution are difficult to achieve in commercial cooling rooms because of the uneven distribution of air flow [4, 5], which in turn is based on the product, the cooling room, the geometry and design parameters of the cooling room.

CFD is the calculation of fluid flow and related phenomena (such as heat and mass transfer) based on the fundamental conservation law of physics in realistic geometries generated by CAD program. With the input of physically meaningful properties and realistic conditions from measurement, CFD generates three dimensional contours and vector plots of all relevant variables (velocity, pressure, temperature, concentrations, heat flux). CFD is accurate and versatile but requires powerful computers and considerable expertise to obtain valid solutions for industry-relevant problems. CFD provides answers where experiments fail or too expensive [6].

M.L. Hoang *et al.* [7] developed an airflow model based on the steady state incompressible, Reynolds-averaged Navier-Stokes equations using commercial code (CFX, Harwell, UK). The turbulence was taken into account using a $k-\epsilon$ model. The finite volume method of discretisation was used. A relative error on the calculated air velocities of 26% was observed. Qian

Zou [8] used CFD to simulate air flow and heat transfer processes in the layered and bulk packaging systems during the forced –air cooling of fresh produces using porous media approach. The solution methods for air flow and heat transfer models were based on SIMPLER (Semi-Implicit Method for Pressure-Linked equations Revised) method schemes. When the predicted and measured product centre temperatures were compared good agreements between the model predictions and experimental data were obtained. M.K. Chourasia *et al.*[9] investigated airflow, heat transfer and moisture loss in a potato cold store of commercial scale under steady state condition using the Computational Fluid Dynamics technique. The model was validated in a commercial scale cold store and was found to be capable of predicting the air velocity as well as product temperature with an average accuracy of 19.5% and 0.5 °C, respectively.

In this study a cooling room model was developed for 3D unsteady state and solved using CFD to predict the air flow and temperature distribution, which helps to improve the variation in the temperature of bulk of yogurt. Being a time dependent model, change in temperature and velocity for every time step can be visualized. Some of the salient points to be considered in the study are: To build a simple model and use powerful computers to solve, thereby consuming less Computational time using readily available user-friendly CFD software package (solid works: flow simulation).

2. METHODOLOGY

2.1 Assumptions

- i) The effect of packing material on the air flow and heat transfer into the stacked yogurt box was negligible.

- ii) The stacked yogurt boxes were considered as a single continuous material.
- iii) The heat transfer in the stack was governed by both conduction and convection mechanism, neglecting the radiation effect in the stacked yogurt.

2.2 Governing Equations

2.2.1 Continuity equation

$$\nabla \cdot (\rho_f U) = S_m \quad (1)$$

The fluid density for incompressible flow was calculated from the empirical formula available in the standard data book [10] for the corresponding fluid temperature and pressure.

2.2.2 Momentum equation

The governing equation based on the conservation of momentum of a Newtonian fluid flow and applied to an infinitesimal small volume in a Cartesian co-ordinate system (x; y; z) is,

$$\nabla \cdot (\rho_f U v_j) = -\nabla p + \nabla \cdot (\mu_{eff} [\nabla v_j]) + \rho_f \vec{g} + S \quad (2)$$

2.2.3 Energy equation

The energy equation was used to describe the heat transfer inside the stacked yogurt.

$$\nabla \cdot (U (\rho_f E_f + P)) = \nabla \cdot [k_{eff} \nabla T - \sum_i h_i \vec{j}_i] + S^h \quad (3)$$

The energy equation for convection heat transfer between air and stacked yogurt was modelled according to Newton's law of cooling.

$$q_{air-stacked\ yogurt} = -h_t (T_{sSurface} - < T_a >_a) \quad (4)$$

In the above mentioned governing equations, $U (v_1, v_2, v_3)$ is the velocity vector, consisting of the three components v_1, v_2, v_3 (m/s), p is the pressure (Pa); T is temperature ($^{\circ}C$), ρ density (kg/m³) and μ viscosity (kg/ms). μ_T and μ_{eff} are the turbulent and effective viscosity, which are needed for the turbulence model. Turbulent flow was experienced only at the entrance of the fan, hence the turbulence model was not considered in this study.

2.3 Model of the Yogurt Cooling Room

3D view of a yogurt cooling room is as shown in Fig.2. Inside the cooling room, the individual retail yogurt cups (125gm) are packed in a carton box (12 nos.each), made up of corrugated fibre board, a paper based material consisting of a fluted corrugated sheet and two flat linear boards. Carton boxes are stacked one over the other to a height of .85 m (10 boxes) in a wooden pallet as shown in Fig.3.

Refrigeration effect was provided by cold water module system in which the cold water flows through the series of cooling coils made up of bare tubes. Cooling coil temperature is considered as constant and neglected from the design model. Blowing fans are mounted in front of the cooling coil to circulate the cold air into room (2 no's each) at the both sides of the wall as shown in Fig.2. Dimension of the single stacked yogurt pallet in the cooling room is of the order 0.85 m in height, 1.35 m in length and 1.05 m in width. The pallets are arranged in

two rows each containing 5 pallets with a gap of .25 m (x, z directions). The cool down time of the palletized yogurt is of the order of 4 hours (measured at surface). Therefore, the transient time for temperature reduction was continued for 4.5 hours.

2.4 Geometry and Boundary Conditions

A small scale yogurt cooling room was used in this study with a total storage capacity of 4000 kg. The input parameters of the model are listed in the Table.1. Dimensions of the cooling room were as follows 7.75 m in length, 3.8 m width and 3.0 m height. The side walls of the room are made of insulating polyurethane foam material (PUF), thereby walls are made as adiabatic in the geometry of the model. Cooling fans (sweep-0.5m; speed- 1400rpm; air flowrate-380m³ min⁻¹) were placed at height of 2.3 m from the floor in the midpoint of the side walls located at the x- coordinate. The boundary conditions of the cooling room were measured consecutively for 36 hours for each batch of product.

2.5 Mesh Generation and Solver Method

The airflow and heat transfer models presented in this study were made up of groups of partial differential equations (PDEs) and auxiliary equations. It was impossible to solve these PDEs analytically on complex domains inside the product, so numerical solutions were taken as approximations. The process of obtaining the numerical solutions consisted of two stages. The first stage was discretisation that employed the finite volume method (FVM) to convert the governing transport and energy equations into discrete algebraic equations. The second stage was to solve these algebraic equations [8, 12]. The geometry of the cooling room model was meshed with hexahedral cells into 21875 control volumes of which 10554 fluid cells, 1844 solid cells and 9477 partial cells. Solution to the model was solved based on the finite volume method (FVM) in which the Computational domain is divided into finite number of small control volumes (cells) by a grid as shown in Fig.4. Algebraic equations are set up for each grid cell and the whole set of equations are solved using a numerical method (explicit approach).

2.6 Validation of the Model

2.6.1 Temperature measurements

The simulated cooling room model was validated by measuring the temperature of stacked yogurt boxes at various points. Thermocouple named Temprecord - 5.27.0.1882 of model (M0079229) was used to measure the temperature of the product in the pallet. Location of thermocouple for measurement in one point of the stack is shown in Fig.5. Similarly the thermocouples were placed at different locations (centre, top, and bottom) to know the variation in temperature within a single palletized yogurt. Moreover temperature measurements were taken for various pallets in the room.

2.6.2 Velocity measurements

Velocity measurements are done using digital anemometer in the various regions of the air flow inside the cooling room. Higher velocity of 1 m/s was

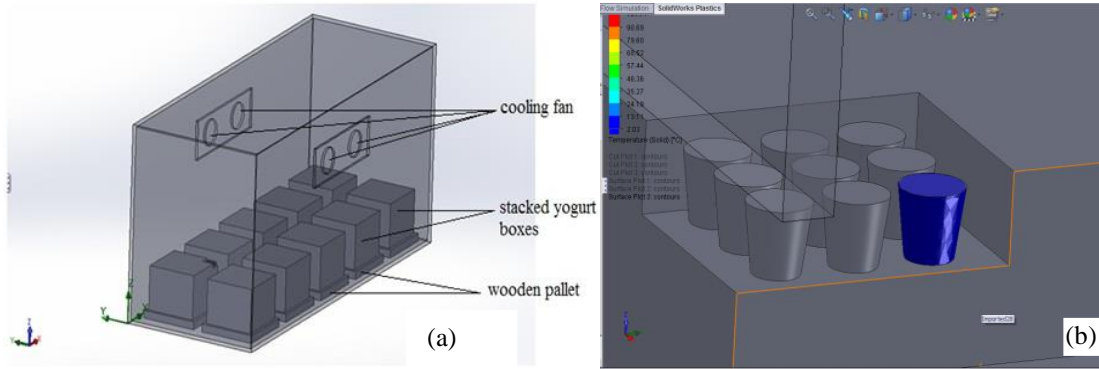

Fig. 2 .(a) 3D view of a yogurt cooling room model with pallet arrangement (b) retail cups arrangement in a carton box of the model.

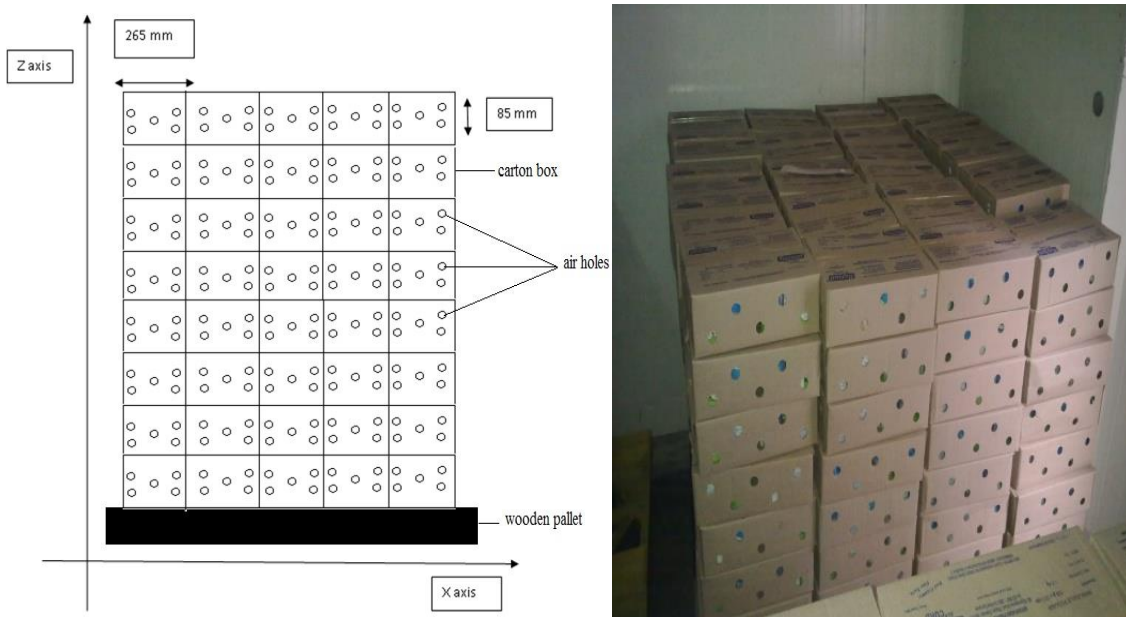

Fig. 3. Side view (x, z axis) of a single stacked palletized yogurt with carton box arrangement.

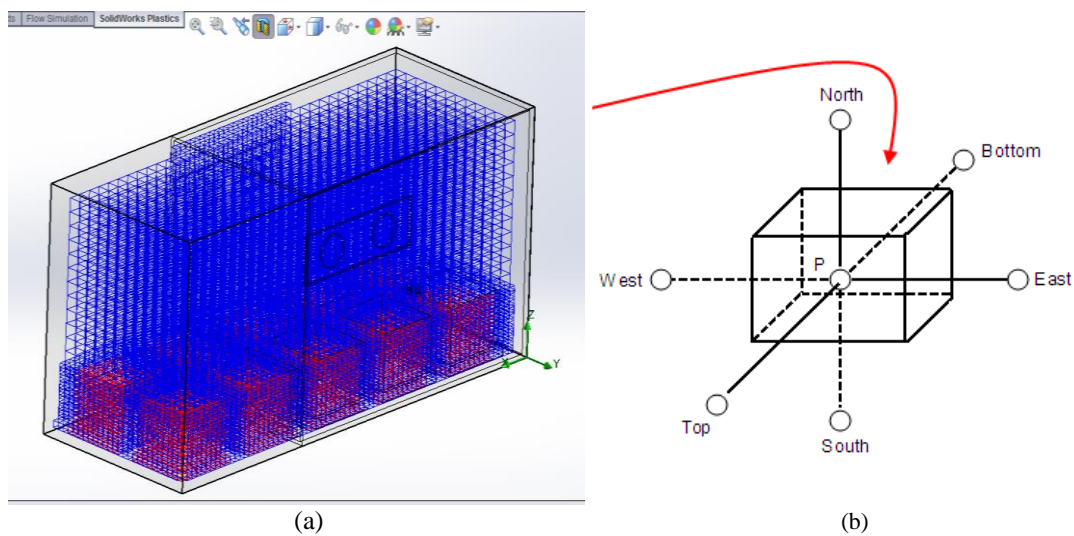

Fig. 4. (a) Geometry of the cooling room divided into finite volume grid (fluid and solid cells) respectively. (b) Representation of finite volume grid with neighbouring points



Fig. 5. location of thermocouple at various points in the stack of yogurt

Table 1 Input parameters of the cooling room model

Parameters	Value
Thermal conductivity of yogurt k_y (W/mK)	0.467 [11]
Specific heat of yogurt $C_{p,y}$ (KJ/Kg K)	235.34 (calculated)
Density of yogurt ρ_y (g/cm ³)	1.071 (calculated)
Initial product temperature $T_{initial}$ (°C)	40 (measured)
Cooling coil temperature T_c (°C)	1 (measured)
Bulk density of stacked yogurt ρ_b (kg/m ³)	317 (calculated)
Density of inlet cold air ρ_{fluid} (kg/m ³)	1.2690 (calculated)
Specific heat of cold air $C_{p,fluid}$ (KJ/Kg K)	1.005 (calculated)

recorded at the entrance of the fan and gradually attains a steady flow in the rest of the region with velocity not greater than 0.1 m/s. Only flow pattern inside the cooling room has significant effect in the variation of temperature in the product.

3. RESULTS AND DISCUSSIONS

3.1 Air Flow Pattern and Velocity Distribution

Velocity vectors distribution of the cooling air inside the room was obtained from the results as shown in Fig.6. Velocity distribution was presented for all the three global Cartesian coordinates(x, y, and z). From the obtained results, velocity of cooling air was found to be predominant in the y- axis compared to the x and z axis of the global coordinates. Maximum velocity of 0.7 m/s was recorded in the y- axis at the fan entrance and decreased to a minimum value of 0.01m/s at the outer surface of the stack near the side walls and at a height of 0.25 m above the stack height in the x- axis of the cooling room. Air flow pattern inside the empty cooling room was analysed as shown in Fig.7. And it clearly depicts the air movement inside the Computational domain. Flow trajectories pronounce that air flow was mostly distributed in the top zone of the room at a height of 1.5 m to 2.5 m. The vorticity (the curl of the air velocity) was created in the region between the cooling fans due to the higher velocity of air at the fan entrance and location of fans such that facing each other. Vortex closes the stream lines and path lines of the air flow resulting in the reduced distribution of air inside the whole geometry of the Computational domain.

3.2 Temperature Distribution

It can be seen from the Fig.8 that the air temperature in the model tends to increase from centre to side walls of the room. Since the model was symmetric with fans placed at the midpoint of the room, equal distribution of temperature were found at the both sides of the room from the midpoint. Vortex formation or re-circulation of air loop also stands for the reduced temperature at the fan entrance. Temperature of yogurt in the stack is mainly dependent on the temperature of cooling air. Temperature distribution of bulk of yogurt in the model was represented in Fig.9. Non-uniform distribution of temperature was found in the bulk of product. Yogurt boxes in the top to centre of the stack attained the required temperature of <10°C, whereas the boxes below the centre of stack and bottom acquires the minimum temperature of 18°C and 22°C respectively.

3.3. Comparison of Results

A comparison between measured and simulated air velocity is shown in Fig.10. As discussed earlier, velocity was higher at inlet section of the room i.e. (Front of the cooling fan) than at any region of the room. Simulated air velocity at the cooling fan 1 & 2 were 30% less compared to the measured air velocity. Similarly air velocity simulated at the centre of the room to the height of 3m also shows 20-30% less compared to the measured air velocity. Fig.10 Shows the comparison of average, measured and simulated temperature at various points in the stack of yogurt. Measured value of yogurt temperature was taken by considering the average value of each yogurt stack.

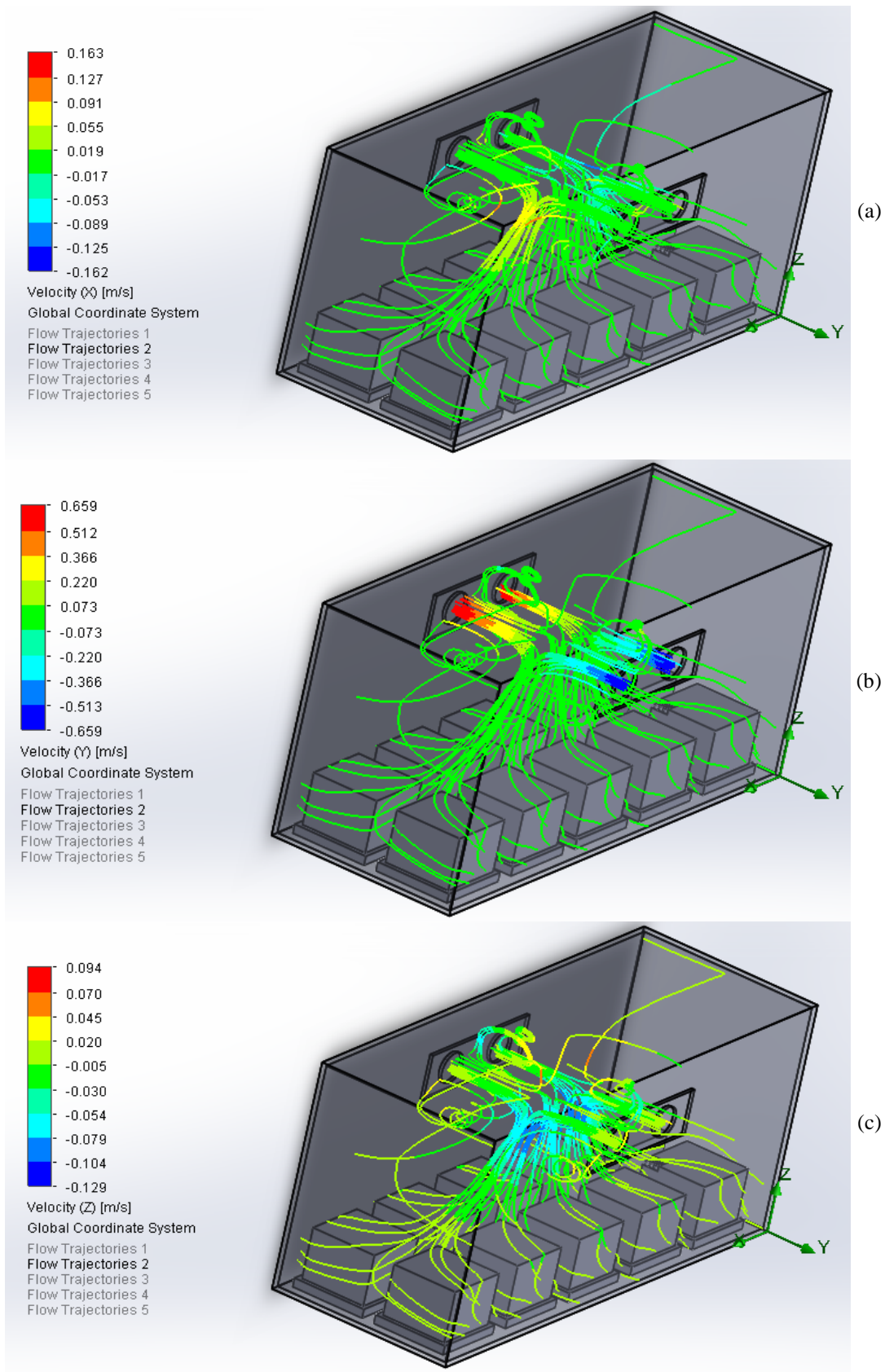

Fig. 6. Predicted, velocity distribution (ms^{-1}) inside a yogurt cooling room model. (a) x- coordinates (b) y- coordinates (c) z- coordinates.

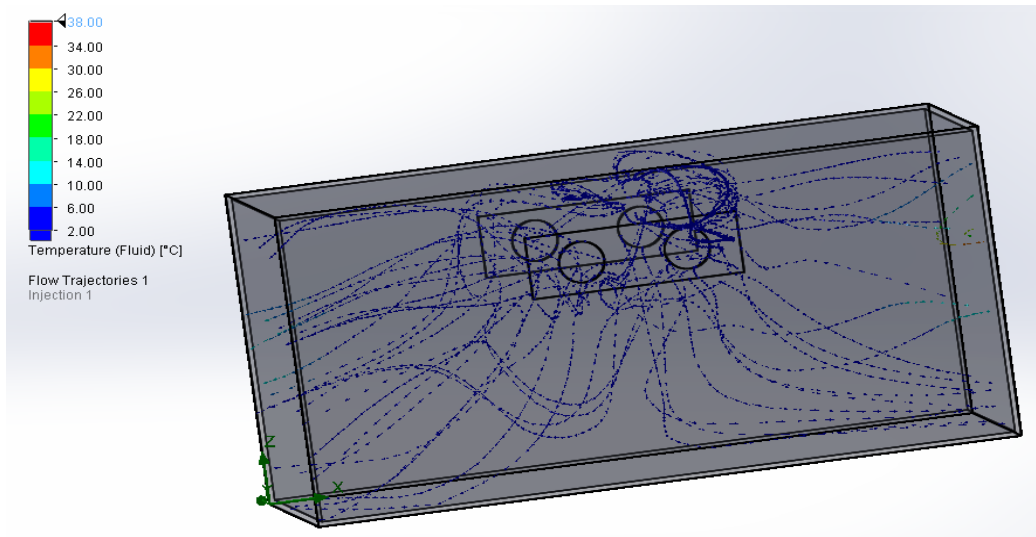

Fig.7. Air flow pattern inside the empty yogurt cooling room model

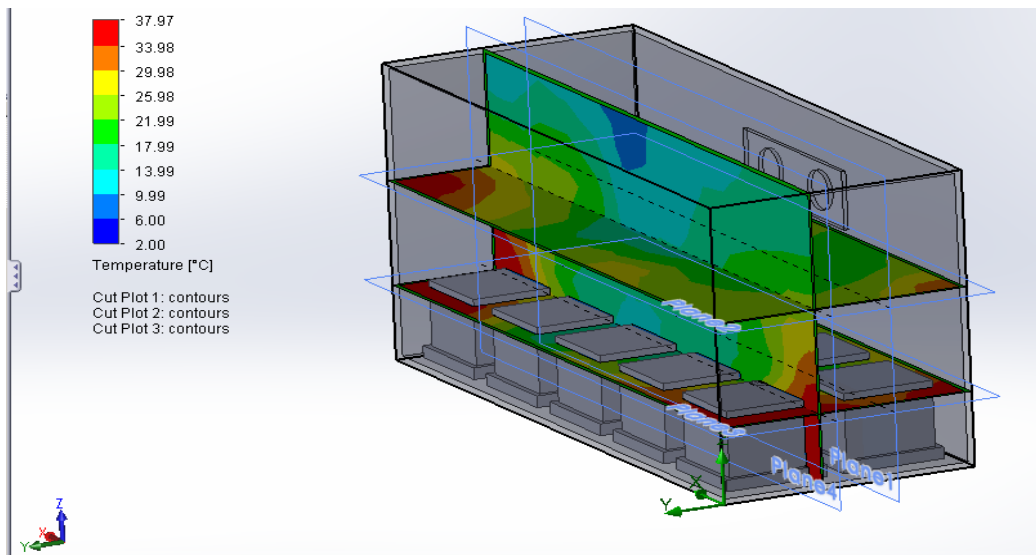

Fig. 8. Contours of air temperature inside the cooling room model

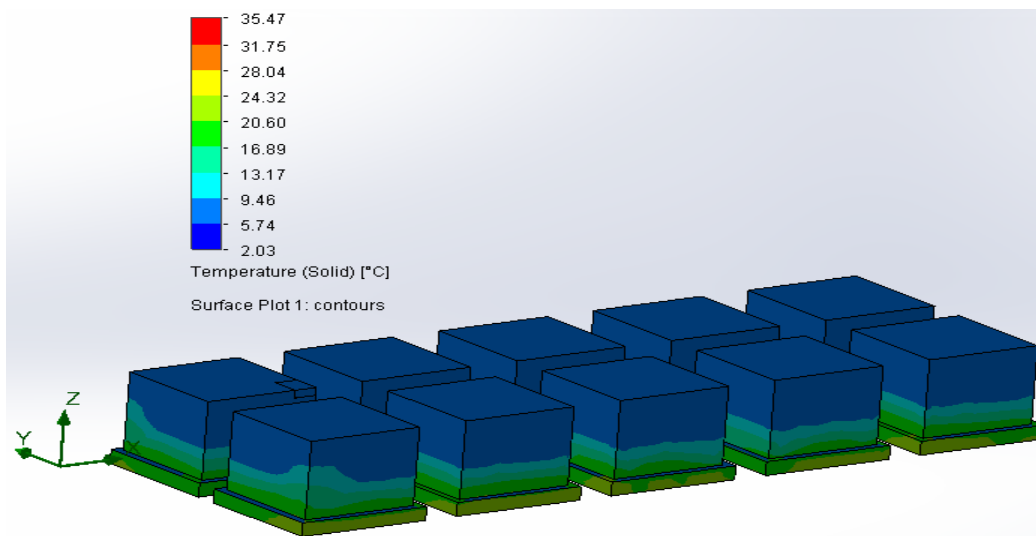

Fig. 9. Contours of temperature distribution in a stack of yogurt

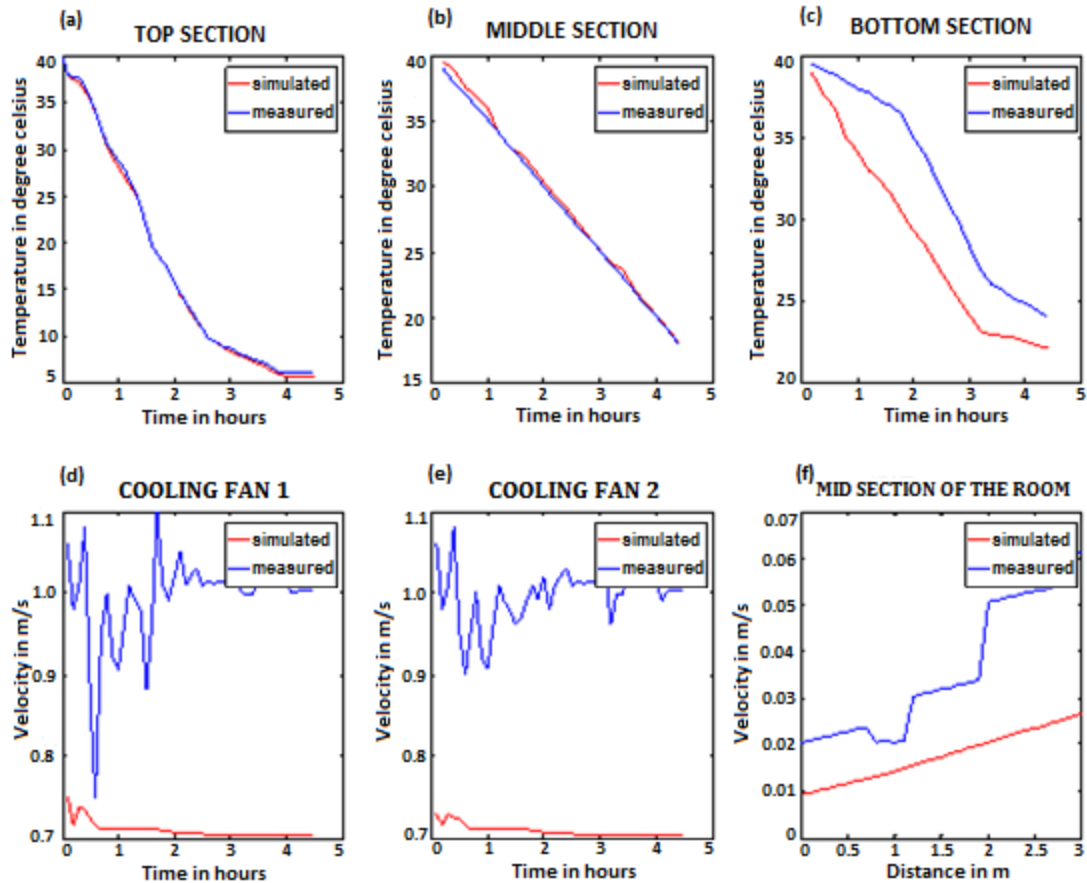

Fig. 10. Comparison of average measured and simulated temperature distribution and velocity profile in the stacked yogurt boxes in the room at different points for 4.5 hour. (a) Temperature at top section of the stack (b) Temperature at middle section of the stack (c) Temperature at bottom section of the stack (d) Velocity at cooling fan 1 (e) Velocity at cooling fan 2 (f) Velocity at the mid section of the room

Comparison shows close agreement with the measured and simulated temperature values at the top and middle section of the yogurt stack. But, the deviation of 2 °C was found at the bottom section of the stack

3.4 Air Flow and Temperature Distribution in the Modified Model.

To attain the required temperature, simulation should be carried out by altering or modifying the refrigeration capacity, air flow pattern, stacking of the yogurt, packing material property and geometry of the room. In the present model it was found that the air flow pattern was not uniform over the surface of product as shown in Fig.6 & Fig.7. Hence, a change in air flow pattern would result in the required output. A new model with small modifications in the location of cooling fans (cooling fan 1&2 were moved 0.5m down the z axis and moved 0.5m towards and away from x-axis respectively) was created and solved as presented in Fig.11. Required results of uniform air flow pattern and temperature distribution inside the alternate cooling model was obtained as shown in Fig.11.

4. CONCLUSIONS

CFD simulation of air flow and heat transfer inside the stacked yogurt cooling room showed close agreement

compared to the experimental results. The present model gave an inside view on the distribution of temperature at unsteady state condition in the stack of yogurt corresponding to the given boundary conditions. From the results, it clearly indicates that temperature of the product was non uniform. It has been concluded that air flow pattern was the main criteria responsible for the temperature variation within the stacked yogurt. Hence, modifications were made to the present model by changing the location of the cooling fans. Simulated results showed better improvement in the temperature variation within the product. Air flow pattern was also distributed evenly throughout the cooling room. Unsteady state model allows us to note the variation in temperature of the product per unit step. Validation of the results for the modified model is in progress. Further extension of the study can be done by performing simulation work on changing the other parameters and boundary conditions of the model.

From this study it was found that CFD analysis improves the food processing by reducing the experimental cost, time and energy. It becomes a powerful numerical tool that is becoming widely used to simulate many processes in the food industry. This paper would induce the young food engineers to explore the studies on application of CFD in food industries.

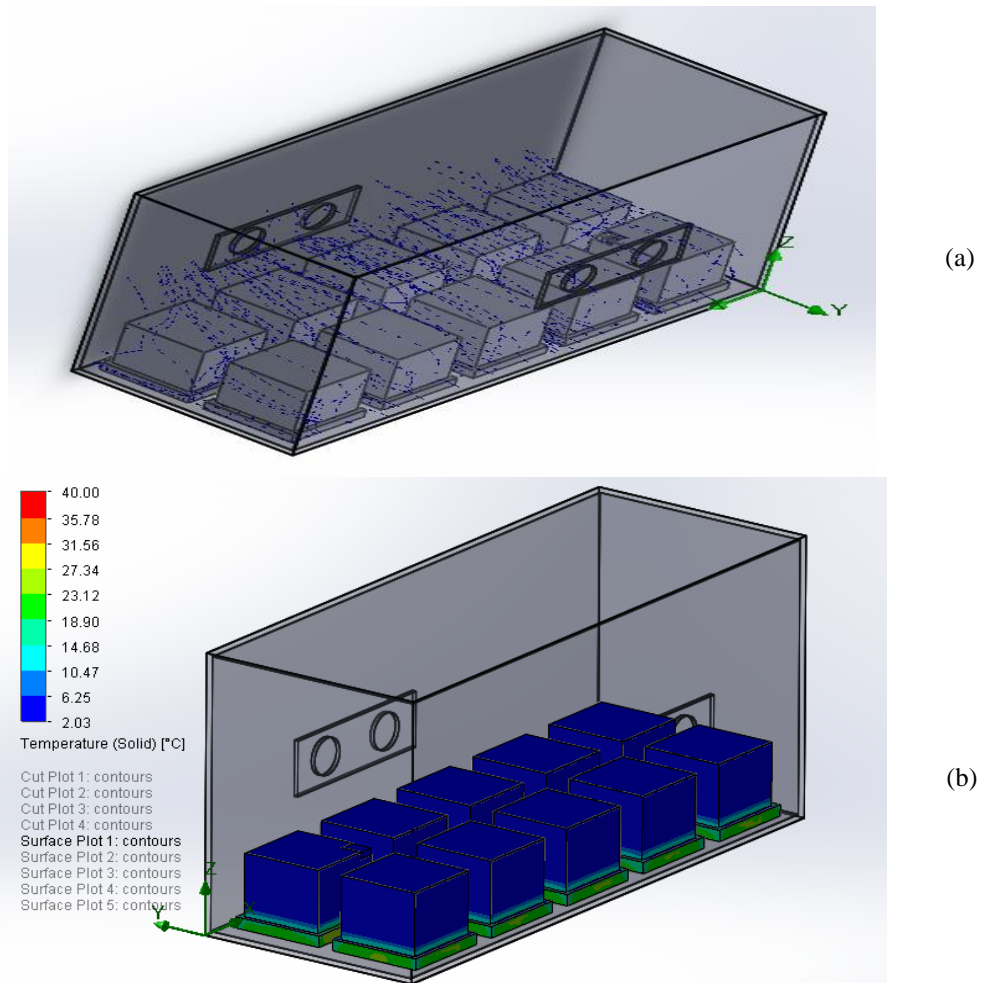

Fig. 11. (a) Air flow pattern and (b) Temperature distribution inside the modified model

REFERENCES

- Bárbara J. Gonçalves, Department of Food Science, Federal University of Lavras – UFLA, Campus Universitário, 37200-000 Lavras, Minas Gerais, Brazil.
- Donna A. Calhoun, Christiane Helzel, Randall J. LeVeque(2008), Logically Rectangular Grids and Finite Volume Methods for PDEs in Circular and Spherical Domains, *Society for Industrial and Applied Mathematics*, Vol. 50, No. 4, pp. 723–752.
- Early (1998), R.E, Technology of Dairy Products, 2nd edition, *Blackie Academic & Professional*, London.
- FAO/WHO (2002). Proposed Draft Revised Standard for Fermented Milks. *Codex Committee on Milk and Milk Products. Doc CX/MMP 02/4 (Jan 2002). Joint FAO/WHO Food Standards Programme.* FAO/WHO, Viale di Caracalla 00100, Rome.
- H.A. Modi (2011), Fermented milk products, *Aavishkar Publishers' Distributors*, India.
- M.K. Chourasia, T.K. Goswami(2006), Steady state CFD modeling of airflow, heat transfer and moisture loss in a commercial potato cold store, *International Journal of Refrigeration* 30 (2007) 672-689.
- M.L. Hoang*, P. Verboven, J. De Baerdemaeker, B.M. Nicolai(2000), Analysis of the air flow in a cold store by means of Computational Fluid Dynamics, *International Journal of Refrigeration* 23 127-140.
- Mirade PS, Daudin JD(1998), Numerical simulation and validation of the air velocity field in a meat chiller. *International Journal of Applied Science and Computations*; 5(1):11-24.
- Pieter verboven, Bart M. Nicolai, Computational Fluid Dynamics- a fresh breeze in engineering and design of food cooling processes, *Preprints of the 18th IFAC World Congress Milano (Italy) August 28, Belgium.*

Qian Zou (2002), *A CFD modelling system for air flow and heat transfer in ventilated packing systems during forced- air cooling of fresh produce*, PhD thesis, Massey University.

Robert H.Perry, Don Green, *Perry's chemical engineers handbook, 6th edition, McGraw- Hill International Editions.*

Wang H, Toubert S (1990), Distributed dynamic modelling of a refrigerated room. *International Journal of Refrigeration*; 13:214-22.