

Accepted Manuscript

Water Distribution Networks Optimization Considering Unknown Flow Directions and Pipe Diameters

Jose A. Caballero , Mauro A.S.S. Ravagnani

PII: S0098-1354(19)30387-4
DOI: <https://doi.org/10.1016/j.compchemeng.2019.05.017>
Reference: CACE 6451



To appear in: *Computers and Chemical Engineering*

Received date: 8 April 2019
Revised date: 6 May 2019
Accepted date: 9 May 2019

Please cite this article as: Jose A. Caballero , Mauro A.S.S. Ravagnani , Water Distribution Networks Optimization Considering Unknown Flow Directions and Pipe Diameters, *Computers and Chemical Engineering* (2019), doi: <https://doi.org/10.1016/j.compchemeng.2019.05.017>

This is a PDF file of an unedited manuscript that has been accepted for publication. As a service to our customers we are providing this early version of the manuscript. The manuscript will undergo copyediting, typesetting, and review of the resulting proof before it is published in its final form. Please note that during the production process errors may be discovered which could affect the content, and all legal disclaimers that apply to the journal pertain.

Highlights

- A new deterministic model for WDN optimization is proposed considering unknown flow directions.
- The minimum WDN cost model considers a set of available commercial diameters.
- No hydraulic simulator is used for calculating pressures and velocities.
- Disjunctive programming is used in the model formulation.
- Global optimum solutions were obtained.

ACCEPTED MANUSCRIPT

Water Distribution Networks Optimization Considering Unknown Flow Directions and Pipe Diameters

Jose A. Caballero^a, Mauro A. S. S. Ravagnani^{a,b}

^aInstitute of Chemical Process Engineering, University of Alicante – Spain

^bChemical Engineering Department, State University of Maringá - Brazil

Abstract

Water Distribution Networks (WDN) are present in a large number of industrial processes and urban centers. Reservoirs, pipes, nodes, loops, and pumps compose WDN and their design can be formulated as an optimization problem. The main objective is the minimization of the network cost, which depends on the pipe diameters and flow directions known a priori. However, in the design of new WDN in real industrial problems, flow directions are unknown. In the present paper, a disjunctive Mixed Integer NonLinear Programming (MINLP) model is proposed for the synthesis of WDN considering unknown flow directions. Two case studies are employed to test the model and global optimization techniques are used in its solution. Results show that the global optima WDN cost with the correct flow directions is obtained for the studied cases without the necessity of using additional software to calculate pressure drops and velocities in the pipes.

Keywords

Water distribution networks, Optimization, MINLP, Flow directions, Disjunctive Programming

1. Introduction

Water Distribution Networks (WDN) are important systems in the industrial society, whose main objective is to deliver water to consumption nodes at an appropriate pressure and velocity. WDN can be constituted of one or more reservoirs,

consumption nodes and pipes linking these nodes. Very frequently, some of these links can compose closed loops. Water movement can be provided by gravity or by using a pumping system.

This important research field has had an increasing interest in the last decades, from the moment that WDN design started to be formulated as an optimization problem. Majority of WDN optimization works consider the minimization of the network cost, being the pipe diameters the optimization variables, while pipe lengths and flow directions are defined beforehand. Different approaches can be used to develop WDN optimization models involving integer or continuous variables. Most of these approaches lead to complex nonlinear and nonconvex problems and, because of this, global optimization techniques are not commonly used to solve the problem.

Another important feature regarding this subject is that hydraulic calculations in pressurized and looped pipe networks are not an easy task. The presence of loops becomes an even more complex problem. From a mathematical point of view, it means, effectively, solving a system of non-linear equations to calculate pressure drops and velocities.

When water is the fluid used in a looped network, Hazzen-Williams equation can be used:

$$\Delta P = \frac{\alpha F^\beta L}{C^\beta D^\gamma} \quad (1)$$

Where ΔP is the pressure drop between two nodes, F is the volumetric flow rate, L is the pipe length, D is the pipe diameter, C is known as the rugosity coefficient of Hazzen-Williams and α , β and γ are constants that depend on the unities system being used.

As mentioned above, when loops are present, these calculations result more difficult and the nonlinear behavior of the equation is a problem. However, the hydraulic calculations can be done separately using specific software, instead of being part of the

optimization problem. In the majority of published papers in this area, as it is discussed in Section 2, hydraulic simulators are used to calculate pressure drops.

In real industrial plants or urban centers, when a new WDN is designed, differently from the majority of papers published in the literature, flow directions are not known a priori and the optimization problem can become more difficult to solve. In order to contribute to this research field, in the present paper, a Mixed Integer Nonlinear Programming (MINLP) optimization model is developed, considering the flow directions as optimization variables, jointly with the pipes diameters. A disjunctive reformulation is proposed and some logarithmic transformations are introduced in order to make the model more robust. The resulting model has a large number of linear terms. The exponential terms are the only non-linearities present and do not introduce numerical problems. However, the model is still non-convex. Two case studies are used to apply the developed approach and no additional software is used in pressure drop and velocity calculations, once these calculations are part of the MINLP model.

2. State of the Art

In the last five decades, important approaches have been published in Water Distribution Networks (WDN) design. Different approaches using deterministic and stochastic techniques were used and different models involving Linear Programming (LP) and Non Linear Programming (NLP), Mixed Integer Linear Programming (MILP) and Mixed Integer Non Linear Programming (MINLP) formulations have been used to tackle the problem. Obviously, Nonlinear Programming formulations are more realistic in real WDN design problems, due to the pressure drop and velocity calculation equations. Most of the studied cases are nonconvex problems and, in these cases, global optimal solutions are not ensured.

Alperovits and Shamir (1977) proposed a Linear Programming Gradient (LPG) method to the optimal WDN design. The method has two steps: in the first stage an LP problem is solved for given feasible flow distribution and in the second stage a search

is conducted in the space of flow variables, based on the gradient of the objective function. One of the most know benchmark problems in this area, named Two Loop WDN, was proposed in this paper. Their approach was used by Goulter et al. (1986), who discussed the importance of head loss path choice in the optimization problem; Kessler and Shamir (1989), who presented an analysis of the LGP method and presented a matrix formulation for both stages using well-known graph theory matrices and Eiger et al. (1994), who presented a semi-infinite linear dual problem to develop an equivalent finite linear problem. The overall design problem was solved globally by a branch and bound algorithm, using non-smooth optimization and duality theory.

In Hansen et al. (1991) a successive linear programming algorithm with a local search approach was proposed to solve the WDN design optimization problem. Sarbu and Borza (1997) obtained good results using an improved LP model for the optimal design of new WDN as well as for the extension of existing WDN. Costa et al. (2001) and Morsi et al. (2012) presented mixed integer linear programming (MILP) models in solving WDN optimization problems using, to achieve the solutions, Branch and Bound method. Páez et al. (2014) combined Mixed Integer Programming (MIP) and energy use in finding near-optimal solutions with reduced amounts of time in WDN design with pressure-driven models.

Considering NLP formulations for the design of optimal WDN, the first work was published by Shamir and Howard (1968). Newton-Raphson method was used to solve the system of equations. Five years later, Watanatada (1973) also presented an NLP formulation for the WDN optimal design. The problem constraints considered mass and energy balances and physical limits. The inequality constraints were eliminated by a transformation of Box, from which Haarhoff and Buys' method for equality constraints was used to solve the remaining part of the problem.

Mixed Integer NonLinear Programming models were also proposed in the literature. Bragalli et al. (2008) proposed a nonconvex continuous NLP relaxation and a MINLP search. Authors used different solvers, like Ipopt, MIINLP_BB, and Bonmin, in

the environment AMPL. D'Ambrosio et al. (2015) surveyed mathematical programming approaches in WDN and overviewed on the more specific modeling aspects in each case, developing a MINLP model to describe water dynamics in pipes and used spatial branch and bound and piecewise linear relaxations.

The majority of published papers, however, use nondeterministic approaches to solve the problem. The most used approaches are based on Genetic Algorithms (GA), as can be seen in the papers of Goldberg and Kuo (1987), Simpson and Goldberg (1994), Dandy et al. (1996), Savic and Walters (1997), Abebe and Solomatine (1998), Montesinos et al. (1999), Gupta et al. (1999), Vairavamoorthy and Ali (2005), Reza and Martínez (2006), Kadu et al. (2008), Van Dijk et al. (2008), Krapivka and Ostfeld (2009), Haghghi et al. (2011), Bi et al. (2015) and Zheng et al. (2013).

Other meta-heuristics were used, such as Ant Colony Optimization (ACO), a meta-heuristic approach based on ant behavior and its pheromone ways, used by Maier et al. (2003) and Zecchin et al. (2006).

Geem et al. (2001), Geem et al. (2002), Geem (2006) and Geem (2009) proposed an interesting meta-heuristic technique known as Harmony Search (HS), based on the improvisations used by jazz musicians.

In the works of Suribabu and Neelakantan (2006), Montalvo et al. (2008), Ezzeldin et al. (2014), Qi et al. (2015) and Surco et al. (2017), Surco et al. (2018) and Surco et al. (2019), Particle Swarm Optimization (PSO) was used to solve the optimization problem.

Loganathan et al. (1995) and Cunha and Sousa (1999) proposed a Simulated Annealing (SA) approach. De Corte and Sorensen (2016) reviewed the metaheuristic techniques used in the optimal design of WDN. It is very interesting to note that most of the works published in the literature applying meta-heuristic techniques use also hydraulic simulators to solve pressure drop and velocity equations. EPANET (Rossman, 2000) is the most used WDN simulation model.

In the present paper, a MINLP optimization model is proposed to solve the

optimal design of WDN, without using additional software for hydraulic calculations and considering flow directions as optimization variables. The model development is presented in the next section.

3. Optimization model development

The design of WDN can be treated as an optimization problem described as it follows: Given is a set of reservoirs and demand points (nodes), with fixed distances and proper elevations, with the possibility of loops existence between nodes, the network total cost (\$), given by the summation of the product between pipes diameters and its lengths, must be minimized. The optimization variables are nodes pressures, pipes velocities, and diameters, which must belong to a set of available commercial diameters with specific costs and rugosities. Hazzen-Williams equation is used in hydraulic calculations and pressure in nodes and fluid velocities in pipes must obey a minimum limit. It can be also considered the possibility of using pumping systems if only gravity is not enough to ensure water movement.

For the development of the WDN Water Distribution Networks disjunctive mathematical model, we define the following index sets:

| | |
|-----------|---|
| $Nodes$ | $\{ i \mid i \text{ is a node} \};$ |
| DI | $\{ k \mid k \text{ is a possible diameter for the pipe} \};$ |
| $R_{i,j}$ | There is a pipe connecting node i with node j ; |

The following parameters are used:

| | |
|------------|--|
| h_i | Elevation of node i (m); |
| $Demand_i$ | Water demand for node i (m^3/h); |
| D_k | Set of diameters available for each pipe (m). |
| Ent_i | i is a reservoir node. Ent makes reference to the flow entering from that node to the network (m^3/h); |

| | |
|------------------------------|--|
| $L_{i,j}$ | Length of pipe connecting node i and node j (m); |
| $CostD_k$ | Unitary cost (\$/m) of pipe $i-j$ if we select diameter k ; |
| $C_{i,j,k}$ | Rugosity coefficient of pipe $i-j$ if we select diameter k in the Hazen-Williams equation; |
| V_{\max}, V_{\min} | Maximum and minimum values for water velocity in pipe $i-j$ (m/s); |
| α, β and γ | Hazen-Williams equation parameters (depend on the unities system being used). |

The following variables are considered in the model:

Continuous Variables

| | |
|---------------------|--|
| V_{ij} | Water velocity in pipe $i-j$ (m/s) |
| v_{ij} | $\ln(V)$ Natural logarithm of velocity [$\ln(\text{m/s})$] |
| $F_{i,j}$ | Volumetric flow rate in pipe $i-j$ (m^3/h) |
| $f_{i,j}$ | $\ln(F_{i,j})$ Natural logarithm of the volumetric flow rate [$\ln(\text{m}^3/\text{h})$] |
| $F_{i,j}^1$ | Equal to flow f if the water flows from node i to node j |
| $F_{i,j}^2$ | Equal to flow f if the water flows from node j to node i |
| P_i | Excess of pressure of node i over the elevation h_i (m) |
| E_{pump_i} | Pump in pipe $i-j$. Eventually, it can become in a variable, in that case, a cost must be given to each pump (m); |
| $\Delta P_{i,j}$ | Pressure drop in pipe $i-j$ |
| $\Delta p_{i,j}$ | $\ln(\Delta P_{i,j})$ Natural logarithm of pressure drop in pipe $i-j$ |
| $\Delta P_{i,j}^1$ | Pressure drop in the pipe if the water flows from node i to node j |
| $\Delta P_{i,j}^2$ | Pressure drop in the pipe if the water flows from node j to node i |

Boolean /Binary Variables

We use capital letters for Boolean variables and small letters to binary variables:

$Y_{i,j,k} / y_{i,j,k}$ True (1) if in the pipe $i-j$ the diameter k is selected. False (0) elsewhere.

$W_{i,j}^1 / w_{i,j}^1$ True (1) if the water flows in direction $i-j$

$W_{i,j}^2 / w_{i,j}^2$ True (2) if the water flows in direction $j-i$

The model is formed by the following equations

Mass balance in each node:

$$\sum_{j \in R_{j,i}} (F_{j,i}^1 - F_{j,i}^2) + Ent_i = \sum_{j \in R_{i,j}} (F_{i,j}^1 - F_{i,j}^2) + Demand_i \quad \forall i \in Nodes \quad (1)$$

The left-hand side of equation (1) is the sum of all the flows entering to node i from node j . Note that in the set R we have reversed the order indicating that we are considering all pipes entering to node i . The major difficulty is that into the loops we do not know, a priori, in which direction is flowing the water, so we express the flow as the difference of two terms. The term with superscript '1' indicates that the water is flowing in the direction defined by the set R . The superscript '2' indicates that the water is flowing opposite to that direction. For example, if we define the set « $R_{1,2}$ » then we assume that $F_{1,2}^1$ will take a positive value if actually the water flows from node 1 to node 2, and $F_{1,2}^2$ will take a positive value if the water is flowing from node 2 to node 1.

The velocity in a pipe depends on the flow and on the diameter that is circulating in that pipe. It can be written using the following disjunction:

$$\bigvee_{k \in DI} \left[V_{i,j} = \frac{F_{i,j}}{\frac{\pi}{4} D_k^2} \right] \quad \forall (i, j) \in R_{i,j} \quad (2)$$

The difference of pressures into two nodes in a pipe can be written as follows:

$$P_i + h_i - \Delta P_{i,j}^1 + \Delta P_{i,j}^2 + Epump_{i,j} = P_j + h_j \quad \forall (i, j) \in R_{i,j} \quad (3)$$

$\Delta P_{i,j}^1$ is the pressure drop when the water flows from node i to node j , in another case it must be zero. $\Delta P_{i,j}^2$ is the pressure drop when the water flows from node j to node i . In another case it must be zero.

To calculate the pressure drop in a pipe it is used the Hazen-Williams equation, which depends on the selected diameter. It can be written using the following disjunction:

$$\bigvee_{k \in DI} \left[\begin{array}{c} Y_{i,j,k} \\ \Delta P = \frac{\alpha F^\beta L}{C^\beta D^\gamma} \end{array} \right] \forall (i, j) \in R_{i,j} \quad (4)$$

To force the flows $(F_{i,j}^1, F_{i,j}^2)$ and pressure drops $(\Delta P_{i,j}^1, \Delta P_{i,j}^2)$ to take a value different from zero (between their lower and upper bounds) if the flow is going in the direction $i-j$ (or $j-i$) we introduce two new Boolean variables. The first one is $W_{i,j}^1$, which takes the value of 'True' if the water flows from node i to node j and zero otherwise. The second one is $W_{i,j}^2$, which takes the value of 'True' if the water flows from node j to node i , and zero otherwise:

$$\left[\begin{array}{c} W_{i,j}^1 \\ F_{i,j} = F_{i,j}^1 \\ \Delta P_{i,j} = \Delta P_{i,j}^1 \\ F_{i,j}^{Lo} \leq F_{i,j} \leq F_{i,j}^{Up} \\ \Delta P_{i,j}^{Lo} \leq \Delta P_{i,j} \leq \Delta P_{i,j}^{Up} \end{array} \right] \bigvee \left[\begin{array}{c} W_{i,j}^2 \\ F_{i,j} = F_{i,j}^2 \\ \Delta P_{i,j} = \Delta P_{i,j}^2 \\ F_{i,j}^{Lo} \leq F_{i,j} \leq F_{i,j}^{Up} \\ \Delta P_{i,j}^{Lo} \leq \Delta P_{i,j} \leq \Delta P_{i,j}^{Up} \end{array} \right] \forall (i, j) \in R_{i,j} \quad (5)$$

The cost of a pipe depends also on the diameter. Therefore, we can write the following disjunction:

$$\bigvee_{k \in DI} \left[\begin{array}{c} Y_{i,j,k} \\ Cost_{i,j} = L_{i,j} Cost D_k \end{array} \right] \forall (i, j) \in R_{i,j} \quad (6)$$

The objective function to be minimized is the total cost:

$$\min : \sum_{(i,j) \in R_{i,j}} Cost_{i,j} \quad (7)$$

Note that disjunctions (2), (4) and (6) could be grouped in single disjunction, but we maintain the separation just for the sake of clarity. The final model is, then, formed by equations (1-7). It is possible to reformulate the model either using a Big M approach or a Hull reformulation, as proposed by Sawaya and Grossmann (2017) and Trespacios and Grossmann (2015). However, the resulting model is highly non-linear and nonconvex and it is really difficult just simply find a single feasible solution. Instead, we proposed a new reformulation. First, we take logarithms in the non-linear terms of disjunctions (2 and 4):

$$\bigvee_{k \in DI} \left[\begin{array}{c} Y_{i,j,k} \\ Ln(F_{i,j}) = Ln(V_{i,j}) + Ln\left(\frac{\pi}{4} D_k^2\right) \end{array} \right] \quad \forall (i, j) \in R_{i,j} \quad (8)$$

$$\bigvee_{k \in DI} \left[\begin{array}{c} Y_{i,j,k} \\ Ln(\Delta P_{i,j}) = Ln(\alpha L_{i,j}) + \beta Ln(F_{i,j}) - Ln\left(C_{i,j,k}^\beta D_k^\gamma\right) \end{array} \right] \quad \forall (i, j) \in R_{i,j} \quad (9)$$

Now we define the following new variables:

$$\begin{aligned} v_{i,j} &= Ln(V_{i,j}) \\ f_{i,j} &= Ln(F_{i,j}) \\ \Delta p_{i,j} &= Ln(\Delta P_{i,j}) \end{aligned} \quad (10)$$

If we use the new variables in disjunctions (8), (9) all the terms in the equations are linear, because of pipe lengths and diameters, as well as Hazzen-Williams rugosity coefficients, are known values. The Hull reformulation of disjunctions (6), (8) and (9) with the change of variables and introducing the binary variables $y_{i,j,k}$ is:

$$\begin{aligned} f_{i,j} &= v_{i,j} + \sum_{k \in DI} \left(Ln\left(\frac{\pi}{4} D_k^2\right) \right) y_{i,j,k} \quad \forall (i, j) \in R_{i,j} \\ \Delta p_{i,j} &= Ln(\alpha L_{i,j}) + \beta f_{i,j} - \sum_{k \in DI} \left(Ln\left(C_{i,j,k}^\beta D_k^\gamma\right) \right) y_{i,j,k} \quad \forall (i, j) \in R_{i,j} \end{aligned} \quad (11)$$

$$Cost_{i,j} = \sum_{k \in DI} (Cost D_{i,j,k} L_{i,j}) y_{i,j,k} \quad \forall (i, j) \in R_{i,j}$$

$$\sum_{k \in DI} y_{i,j,k} = 1 \quad \forall (i, j) \in R_{i,j}$$

The last equation in (11) comes directly from the disjunction and indicates that for each pipe i - j only one diameter can be chosen. Note that all equations in (11) are linear. Now we also have to reformulate disjunction (5). Using the hull reformulation:

$$\left. \begin{aligned}
 F_{i,j} &= F_{i,j}^1 + F_{i,j}^2 \\
 F_{i,j}^1 &\geq F_{i,j}^{lo} W_{i,j}^1 \\
 F_{i,j}^1 &\leq F_{i,j}^{Up} W_{i,j}^1 \\
 F_{i,j}^2 &\geq F_{i,j}^{lo} W_{i,j}^2 \\
 F_{i,j}^2 &\leq F_{i,j}^{Up} W_{i,j}^2 \\
 \Delta P_{i,j} &= \Delta P_{i,j}^1 + \Delta P_{i,j}^2 \\
 \Delta P_{i,j}^1 &\geq \Delta P_{i,j}^{lo} W_{i,j}^1 \\
 \Delta P_{i,j}^1 &\leq \Delta P_{i,j}^{Up} W_{i,j}^1 \\
 \Delta P_{i,j}^2 &\geq \Delta P_{i,j}^{lo} W_{i,j}^2 \\
 \Delta P_{i,j}^2 &\leq \Delta P_{i,j}^{Up} W_{i,j}^2 \\
 W_{i,j}^1 + W_{i,j}^2 &= 1
 \end{aligned} \right\} \forall (i,j) \in R_{i,j} \quad (12)$$

In order to explicitly relate variables F with f and ΔP with Δp , we must explicitly include the following equations:

$$\begin{aligned}
 \exp(f_{i,j}) &= F_{i,j} \quad \forall (i,j) \in R_{i,j} \\
 \exp(\Delta p_{i,j}) &= \Delta P_{i,j} \quad \forall (i,j) \in R_{i,j}
 \end{aligned} \quad (13)$$

The only nonlinear (and nonconvex) equations are those in equation (13). If we are able to provide tight bounds global solvers like BARON are able to solve the problem to global optimality for medium-size problems.

Therefore, the complete model can be written as follows:

$$\min : \sum_{(i,j) \in R_{i,j}} Cost_{i,j}$$

s.t.

$$\sum_{j \in R_{j,i}} (F_{j,i}^1 - F_{j,i}^2) + Ent_i = \sum_{j \in R_{i,j}} (F_{i,j}^1 - F_{i,j}^2) + Demand_i \quad \forall i \in Nodes$$

$$Cost_{i,j} = \sum_{k \in DI} (Cost_{D_{i,j,k}} L_{i,j}) y_{i,j,k}$$

$$P_i + h_i - \Delta P_{i,j}^1 + \Delta P_{i,j}^2 + Epump_{i,j} = P_j + h_j$$

$$f_{i,j} = v_{i,j} + \sum_{k \in DI} \left(Ln \left(\frac{\pi}{4} D_k^2 \right) \right) y_{i,j,k}$$

$$\Delta p_{i,j} = Ln(\alpha L_{i,j}) + \beta f_{i,j} - \sum_{k \in DI} \left(Ln(C_{i,j,k}^\beta D_k^\gamma) \right) y_{i,j,k}$$

$$\sum_{k \in DI} y_{i,j,k} = 1$$

$$F_{i,j} = F_{i,j}^1 + F_{i,j}^2$$

$$F_{i,j}^1 \geq F_{i,j}^{lo} W_{i,j}^1$$

$$F_{i,j}^1 \leq F_{i,j}^{Up} W_{i,j}^1$$

$$F_{i,j}^2 \geq F_{i,j}^{lo} W_{i,j}^2$$

$$F_{i,j}^2 \leq F_{i,j}^{Up} W_{i,j}^2$$

$$\Delta P_{i,j} = \Delta P_{i,j}^1 + \Delta P_{i,j}^2$$

$$\Delta P_{i,j}^1 \geq \Delta P_{i,j}^{lo} W_{i,j}^1$$

$$\Delta P_{i,j}^1 \leq \Delta P_{i,j}^{Up} W_{i,j}^1$$

$$\Delta P_{i,j}^2 \geq \Delta P_{i,j}^{lo} W_{i,j}^2$$

$$\Delta P_{i,j}^2 \leq \Delta P_{i,j}^{Up} W_{i,j}^2$$

$$W_{i,j}^1 + W_{i,j}^2 = 1$$

$$\exp(f_{i,j}) = F_{i,j}$$

$$\exp(\Delta p_{i,j}) = \Delta P_{i,j}$$

} $\forall (i,j) \in R_{i,j}$

In the previous model, the two last equations are the only non-linear.

4. Case studies

Two case studies are chosen from the literature in order to apply the developed approach. In both cases, the flow directions were considered variables to be optimized, together with the pipes diameters and the total WDN cost.

4.1 Case study 1

This case study is the WDN originally presented by Alperovits and Shamir (1977).

Figure 1 presents the WDN topology. The WDN has one reservoir, eight 1,000 length

m pipes, seven nodes, and two loops. It is supposed that the minimum pressure required in each node is 30 m. Water velocity must be bounded between 0.3 m/s and 3 m/s. Hazen-Williams dimensionless roughness coefficient C is 130 for all links and the Hazzen-Williams equation parameters are $\alpha = 10.667$, $\beta = 4.871$ and $\gamma = 1.852$. A set of commercial diameters, in m, is available and is composed by 14 elements: $D = \{0.0254, 0.0508, 0.0762, 0.1016, 0.1524, 0.2032, .02540, 0.3048, 0.3556, 0.4064, 0.4572, 0.5080, 0.5588, 0.6096\}$. The cost for these specified diameters and nodes elevation and demand are presented in Table 1 and the flow directions are not known a priori and are optimization variables. The problem was solved using BARON, in GAMS. Calculated flow directions, pressure drops and velocities for each pipe are presented in Table 2. In Table 3 it is presented a comparison among single pipe different approaches to solve the problem. As can be seen, the best value found was the WDN cost of \$ 419,000. This is the global optimum and was also obtained by other researchers, like Surco et al. (2017), Zhou et al. (2016) and Ezzeldin et al. (2014).

In all works used for comparison, flow directions are considered fixed a priori and the values calculated by the proposed approach in the present paper are showed in the last column of Table 2.

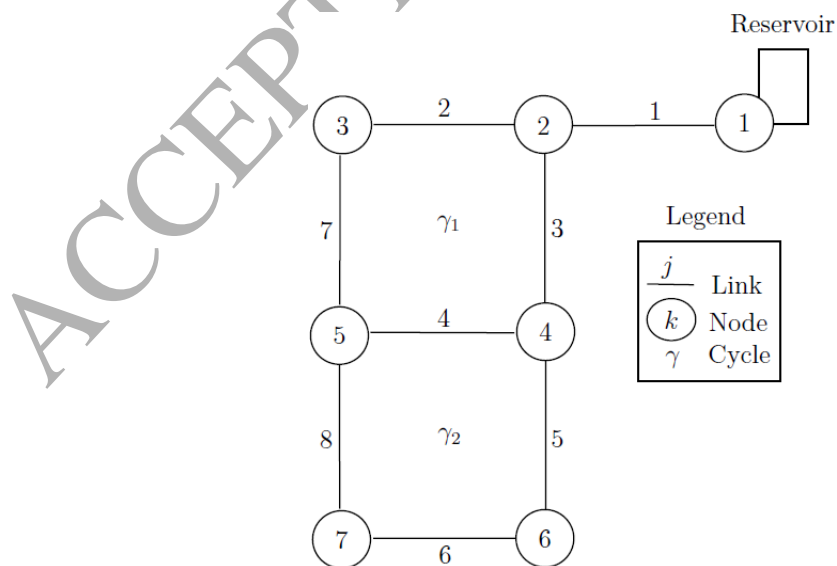

Figure 1 – Two loop WDN topology

Table 1 – Diameters cost and nodes elevation and demand - Two Loop WDN

| Diameter (m) | Cost (\$/m) | Node | Elevation (m) | Demand (m ³ /h) |
|--------------|-------------|------|---------------|----------------------------|
| 0.0254 | 2 | 1 | 210 | - 1120 |
| 0.0508 | 5 | 2 | 150 | 100 |
| 0.0762 | 8 | 3 | 160 | 100 |
| 0.1016 | 11 | 4 | 155 | 120 |
| 0.1524 | 16 | 5 | 150 | 270 |
| 0.2032 | 23 | 6 | 165 | 330 |
| 0.2540 | 32 | 7 | 200 | 160 |
| 0.3048 | 50 | | | |
| 0.3556 | 60 | | | |
| 0.4064 | 90 | | | |
| 0.4572 | 130 | | | |
| 0.5080 | 170 | | | |
| 0.5588 | 300 | | | |
| 0.6096 | 550 | | | |

Table 2 –Two Loop WDN calculated pressure drops and velocities

| Pipe | Velocity (m/s) | Pressure drops (m) | Flow directions | |
|------|----------------|--------------------|-----------------|------------------|
| | | | Origin Node | Destination Node |
| 1 | 1.9 | 6.76 | 1 | 2 |
| 2 | 1.85 | 12.79 | 2 | 3 |
| 3 | 1.46 | 4.80 | 2 | 4 |
| 4 | 1.12 | 14.65 | 4 | 5 |
| 5 | 1.14 | 3.00 | 4 | 6 |
| 6 | 1.1 | 4.90 | 6 | 7 |
| 7 | 1.3 | 6.66 | 3 | 5 |
| 8 | 0.31 | 6.75 | 7 | 5 |

Table 3 – Optimal diameters (m) comparison

| Pipe | Suribabu (2012) | Ezzeldin et al. (2014) | Zhou et al. (2016) | Surco et al. (2017) | Present work |
|-----------|-----------------|-----------------------------|---------------------------|-----------------------------|--|
| Approach | heuristic based | particle swarm optimization | discrete state transition | particle swarm optimization | disjunctive mathematical programming BARON |
| 1 | .5080 | .4572 | .4572 | .4572 | .4572 |
| 2 | .2540 | .2540 | .2540 | .2540 | .2540 |
| 3 | .4064 | .4064 | .4064 | .4064 | .4064 |
| 4 | .0254 | .1016 | .1016 | .1016 | .1016 |
| 5 | .3556 | .4064 | .4064 | .4064 | .4064 |
| 6 | .2540 | .2540 | .2540 | .2540 | .2540 |
| 7 | .2540 | .2540 | .2540 | .2540 | .2540 |
| 8 | .0254 | .0254 | .0254 | .0254 | .0254 |
| Cost (\$) | 420,000 | 419,000 | 419,000 | 419,000 | 419,000 |

4.2. Case Study 2

This case study was proposed by Fujiwara and Khang (1990) and is known as Hanoi WDN. In Figure 2 it is presented the network topology and the streams flow direction are, as in Case Study 1, considered unknown. In this network, water is fed by gravity and the reservoir (node 1) has an elevation of 100 m and all demand nodes are at level zero. It has 32 nodes, 3 loops, and 34 pipes. The minimum required pressure is 30 m for all nodes. A set with 6 commercial diameters is available. The Hazen-Williams roughness coefficient C equal to 130 for all pipes and 3 different situations were considered, for distinct Hazzen-Williams equation parameters (ω , α and β) and different global optima were obtained for these situations. This choice was made just to show how sensitive is this problem with respect to the pressure drop calculations equation parameters. Table 5 presents the set of available commercial diameters with its respective costs. Table 6 presents nodes demand and pipes length and Table 7 the calculated flow directions, which are the same for all 3 situations.

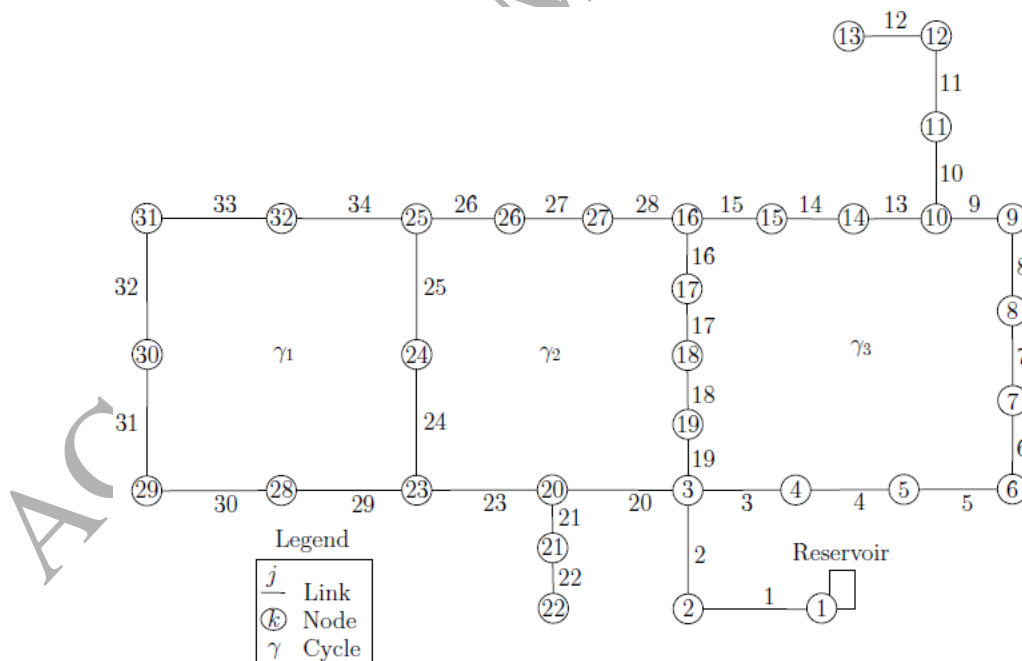

Figure 2 – Hanoi WDN

Table 5 – Hanoi WDN available diameters and respective cost

| Diameter (m) | Cost (\$/m) |
|--------------|-------------|
| 0.3048 | 45.73 |
| 0.4064 | 70.40 |
| 0.5080 | 98.39 |
| 0.6096 | 129.33 |
| 0.7620 | 180.75 |
| 1.016 | 278.28 |

Table 6 – Hanoi WDN nodes demand and pipes length

| Node/Pipe | Node Demand (m ³ /h) | Pipe Length (m) | Node/Pipe | Node Demand (m ³ /h) | Pipe Length (m) |
|-----------|---------------------------------|-----------------|-----------|---------------------------------|-----------------|
| 1 | - 19940 | 100 | 18 | 1345 | 800 |
| 2 | 890 | 1350 | 19 | 60 | 400 |
| 3 | 850 | 900 | 20 | 1275 | 2200 |
| 4 | 130 | 1150 | 21 | 930 | 1500 |
| 5 | 725 | 1450 | 22 | 485 | 500 |
| 6 | 1005 | 450 | 23 | 1045 | 2650 |
| 7 | 1350 | 850 | 24 | 820 | 1230 |
| 8 | 550 | 850 | 25 | 170 | 1300 |
| 9 | 525 | 800 | 26 | 900 | 850 |
| 10 | 525 | 950 | 27 | 370 | 300 |
| 11 | 500 | 1200 | 28 | 290 | 750 |
| 12 | 560 | 3500 | 29 | 360 | 1500 |
| 13 | 940 | 800 | 30 | 360 | 2000 |
| 14 | 615 | 500 | 31 | 105 | 1600 |
| 15 | 280 | 550 | 32 | 805 | 150 |
| 16 | 310 | 2730 | 33 | | 860 |
| 17 | 865 | 1750 | 34 | | 950 |

Table 7 – Calculated pipes flow direction

| Pipe | Origin node | Destination node | Pipe | Origin node | Destination node |
|------|-------------|------------------|------|-------------|------------------|
| 1 | 1 | 2 | 18 | 19 | 18 |
| 2 | 2 | 3 | 19 | 3 | 19 |
| 3 | 3 | 4 | 20 | 3 | 20 |
| 4 | 4 | 5 | 21 | 20 | 21 |
| 5 | 5 | 6 | 22 | 21 | 22 |
| 6 | 6 | 7 | 23 | 20 | 23 |
| 7 | 7 | 8 | 24 | 23 | 24 |
| 8 | 8 | 9 | 25 | 24 | 25 |
| 9 | 9 | 10 | 26 | 26 | 25 |
| 10 | 10 | 11 | 27 | 27 | 26 |
| 11 | 11 | 12 | 28 | 16 | 27 |

| | | | | | |
|----|----|----|----|----|----|
| 12 | 12 | 13 | 29 | 23 | 28 |
| 13 | 10 | 14 | 30 | 28 | 29 |
| 14 | 14 | 15 | 31 | 29 | 30 |
| 15 | 15 | 16 | 32 | 30 | 31 |
| 16 | 17 | 16 | 33 | 32 | 31 |
| 17 | 18 | 17 | 34 | 25 | 32 |

Table 8, 9 and 10 present the results achieved by the current work and a comparison with other papers, for the three different situations, considering different Hazzen-Williams parameters, for diameters pipes and nodes pressures (between parenthesis).

As can be seen in Table 8, in this situation, the parameters used in the Hazzen-Williams equation are $\alpha = 10.6668$, $\beta = 1.852$ and $\gamma = 4.871$. The results obtained by the proposed model, in the present paper, correspond to the global optimum and are exactly the same of the papers of Suribabu (2010), who used a Differential Evolution algorithm to solve the optimization problem and Surco et al. (2017), who used a PSO approach in finding the optimum value for the WDN total cost. In both papers authors used EPANET as the auxiliary hydraulic simulator.

Table 8 - Hanoi WDN, with $\alpha = 10.6668$, $\beta = 1.852$ and $\gamma = 4.871$

| Pipe / Node | Suribabu (2010) | Surco et al. (2017) | Present paper |
|----------------------------|-----------------|---------------------|-----------------|
| 1 | 1.0160 (100.00) | 1.0160 (100.00) | 1.0160 (100.00) |
| 2 | 1.0160 (97.14) | 1.0160 (97.14) | 1.0160 (97.14) |
| 3 | 1.0160 (61.67) | 1.0160 (61.67) | 1.0160 (61.67) |
| 4 | 1.0160 (56.92) | 1.0160 (56.92) | 1.0160 (56.92) |
| 5 | 1.0160 (51.02) | 1.0160 (51.02) | 1.0160 (51.03) |
| 6 | 1.0160 (44.81) | 1.0160 (44.81) | 1.0160 (44.81) |
| 7 | 1.0160 (43.35) | 1.0160 (43.35) | 1.0160 (43.35) |
| 8 | 1.0160 (41.61) | 1.0160 (41.61) | 1.0160 (41.62) |
| 9 | 1.0160 (40.23) | 1.0160 (40.23) | 1.0160 (40.23) |
| 10 | 0.7620 (39.20) | 0.7620 (39.20) | 0.7620 (39.20) |
| 11 | 0.6096 (37.64) | 0.6096 (37.64) | 0.6096 (37.64) |
| 12 | 0.6096 (34.21) | 0.6096 (34.21) | 0.6096 (34.22) |
| 13 | 0.5080 (30.01) | 0.5080 (30.01) | 0.5080 (30.01) |
| 14 | 0.4064 (35.52) | 0.4064 (35.52) | 0.4064 (35.52) |
| 15 | 0.3048 (33.72) | 0.3048 (33.72) | 0.3048 (33.72) |
| 16 | 0.3048 (31.30) | 0.3048 (31.30) | 0.3048 (31.30) |
| 17 | 0.4064 (33.41) | 0.4064 (33.41) | 0.4064 (33.41) |
| 18 | 0.6096 (49.93) | 0.6096 (49.93) | 0.6096 (49.93) |
| 19 | 0.5080 (55.09) | 0.5080 (55.09) | 0.5080 (55.09) |
| 20 | 1.0160 (50.61) | 1.0160 (50.61) | 1.0160 (50.61) |
| 21 | 0.5080 (41.26) | 0.5080 (41.26) | 0.5080 (41.26) |
| 22 | 0.3048 (36.10) | 0.3048 (36.10) | 0.3048 (36.10) |
| 23 | 1.0160 (44.52) | 1.0160 (44.52) | 1.0160 (44.53) |
| 24 | 0.7620 (38.93) | 0.7620 (38.93) | 0.7620 (38.93) |
| 25 | 0.7620 (35.34) | 0.7620 (35.34) | 0.7620 (35.34) |
| 26 | 0.5080 (31.70) | 0.5080 (31.70) | 0.5080 (31.70) |
| 27 | 0.3048 (30.76) | 0.3048 (30.76) | 0.3048 (30.76) |
| 28 | 0.3048 (38.94) | 0.3048 (38.94) | 0.3048 (38.94) |
| 29 | 0.4064 (30.13) | 0.4064 (30.13) | 0.4064 (30.13) |
| 30 | 0.3048 (30.42) | 0.3048 (30.42) | 0.3048 (30.42) |
| 31 | 0.3048 (30.70) | 0.3048 (30.70) | 0.3048 (30.70) |
| 32 | 0.4064 (33.18) | 0.4064 (33.18) | 0.4064 (33.18) |
| 33 | 0.4064 | 0.4064 | 0.4064 |
| 34 | 0.6096 | 0.6096 | 0.6096 |
| Cost (\$ 10 ⁶) | 6.081 | 6.081 | 6.081 |

Table 9 presents the second situation, with values of $\alpha = 10.5088$, $\beta = 1.85$ and $\gamma = 4.87$. The values achieved with the approach proposed in the present paper were compared with the papers of Savic and Walters (1997), who proposed a Genetic Algorithm approach and with Cunha and Souza (1999), who used a Simulated Annealing approach for the optimization problem and a Newton search method was used to solve the hydraulic network equations. Our global optimum cost is the same as the result found by Cunha and Souza (1999). However, in their paper, the authors related pressures below the minimum value of 30 m. These values are identified by the signal (*) and it can be seen in nodes 13, 16, 17, 27, 29 and 30. This violation occurred also in the work of Savic and Walters (1997), in nodes 13 and 30.

Table 9 - Hanoi WDN with $\alpha = 10.5088$, $\beta = 1.85$ and $\gamma = 4.87$

| Pipe / Node | Savic and Walters (1997) | Cunha and Sousa (1999) | Present paper |
|----------------------------|-----------------------------|---------------------------|-----------------|
| 1 | 1.0160 (100.00) | 1.0160 (100.00) | 1.0160 (100.00) |
| 2 | 1.0160 (97.14) | 1.0160 (97.14) | 1.0160 (97.17) |
| 3 | 1.0160 (61.63) | 1.0160 (61.63) | 1.0160 (61.99) |
| 4 | 1.0160 (56.83) | 1.0160 (56.82) | 1.0160 (57.28) |
| 5 | 1.0160 (50.89) | 1.0160 (50.86) | 1.0160 (51.32) |
| 6 | 1.0160 (44.62) | 1.0160 (44.57) | 1.0160 (45.07) |
| 7 | 1.0160 (43.14) | 1.0160 (43.10) | 1.0160 (43.61) |
| 8 | 1.0160 (41.38) | 1.0160 (41.33) | 1.0160 (41.85) |
| 9 | 1.0160 (39.97) | 1.0160 (39.91) | 1.0160 (40.44) |
| 10 | 0.7620 (38.93) | 0.7620 (38.86) | 0.7620 (39.40) |
| 11 | 0.6096 (37.37) | 0.6096 (37.30) | 0.6096 (37.85) |
| 12 | 0.6096 (33.94) | 0.6096 (33.87) | 0.6096 (34.43) |
| 13 | 0.5080 (29.72*) | 0.5080 (29.66*) | 0.5080 (30.24) |
| 14 | 0.4064 (35.06) | 0.4064 (39.94) | 0.4064 (35.49) |
| 15 | 0.3048 (33.07) | 0.3048 (32.88) | 0.3048 (33.44) |
| 16 | 0.3048 (30.15) | 0.3048 (29.79*) | 0.3048 (30.36) |
| 17 | 0.4064 (30.24) | 0.4064 (29.95*) | 0.4064 (30.51) |
| 18 | 0.5080 (43.91) | 0.5080 (43.81) | 0.5080 (44.29) |
| 19 | 0.5080 (55.53) | 0.5080 (55.49) | 0.5080 (55.90) |
| 20 | 1.0160 (50.39) | 1.0160 (50.43) | 1.0160 (50.89) |
| 21 | 0.5080 (41.03) | 0.5080 (41.07) | 0.5080 (41.58) |
| 22 | 0.3048 (35.86) | 0.3048 (35.90) | 0.3048 (36.42) |
| 23 | 1.0160 (44.15) | 1.0160 (44.24) | 1.0160 (44.73) |
| 24 | 0.7620 (38.84) | 0.7620 (38.50) | 0.7620 (39.03) |
| 25 | 0.7620 (35.48) | 0.7620 (34.79) | 0.7620 (35.34) |
| 26 | 0.5080 (31.46) | 0.5080 (30.87) | 0.5080 (31.44) |
| 27 | 0.3048 (30.03) | 0.3048 (29.59*) | 0.3048 (30.15) |
| 28 | 0.3048 (35.43) | 0.3048 (38.60) | 0.3048 (39.19) |
| 29 | 0.4064 (30.67) | 0.4064 (29.64*) | 0.4064 (30.21) |
| 30 | 0.4064 (29.65*) | 0.3048 (29.90*) | 0.3048 (30.47) |
| 31 | 0.3048 (30.12) | 0.3048 (30.18) | 0.3048 (30.75) |
| 32 | 0.3048 (31.36) | 0.4064 (32.64) | 0.4064 (30.20) |
| 33 | 0.4064 | 0.4064 | 0.4064 |
| 34 | 0.5080 | 0.6096 | 0.6096 |
| Cost (\$ 10 ⁶) | 6.073 | 6.056 | 6.056 |

*Pressure nodes violation (values smaller than 30 m)

In the third situation (Table 10), the values used for the Hazzen-Williams parameters were $\alpha = 10.9031$, $\beta = 1.852$ and $\psi = 4.871$, and the results found by the model presented in the present paper were compared to the works of Savic and Walters (1997), cited before, in the first situation, and Liong and Atiquzzaman (2004), who used a Shuffled Complex Evolution optimization approach and EPANET as hydraulic simulator. The results achieved by the proposed method in the present paper correspond to the global optimum and the WDN cost is better than the results obtained in the cited papers from the literature.

Table 10 - Hanoi WDN with $\alpha = 10.9031$, $\beta = 1.852$ and $\psi = 4.871$

| Pipe / Node | Savic and Walters (1997) | Liong and Atiquzzaman (2004) | Present paper |
|----------------------------|--------------------------|------------------------------|-----------------|
| 1 | 1.0160 (100.00) | 1.0160 (100.00) | 1.0160 (100.00) |
| 2 | 1.0160 (97.14) | 1.0160 (97.14) | 1.0160 (97.08) |
| 3 | 1.0160 (61.63) | 1.0160 (61.67) | 1.0160 (60.82) |
| 4 | 1.0160 (57.26) | 1.0160 (57.54) | 1.0160 (56.27) |
| 5 | 1.0160 (51.86) | 1.0160 (52.43) | 1.0160 (50.64) |
| 6 | 1.0160 (46.21) | 1.0160 (47.13) | 1.0160 (44.73) |
| 7 | 1.0160 (44.91) | 1.0160 (45.92) | 1.0160 (43.37) |
| 8 | 1.0160 (43.40) | 0.7620 (44.55) | 1.0160 (41.77) |
| 9 | 0.7620 (42.23) | 0.7620 (40.27) | 1.0160 (40.52) |
| 10 | 0.7620 (38.79) | 0.7620 (37.24) | 0.7620 (39.61) |
| 11 | 0.7620 (37.23) | 0.7620 (35.68) | 0.6096 (38.02) |
| 12 | 0.6096 (36.07) | 0.6096 (34.52) | 0.6096 (34.52) |
| 13 | 0.4064 (31.86) | 0.4064 (30.32) | 0.4064 (30.22) |
| 14 | 0.4064 (33.19) | 0.3048 (34.08) | 0.3048 (32.76) |
| 15 | 0.3048 (32.90) | 0.3048 (34.08) | 0.3048 (30.49) |
| 16 | 0.4064 (33.01) | 0.6096 (36.13) | 0.3048 (30.46) |
| 17 | 0.5080 (40.73) | 0.7620 (48.64) | 0.5080 (43.51) |
| 18 | 0.6096 (51.13) | 0.7620 (54.00) | 0.6096 (51.49) |
| 19 | 0.6096 (58.03) | 0.7620 (59.07) | 0.6096 (57.62) |
| 20 | 1.0160 (50.63) | 1.0160 (53.62) | 1.0160 (49.29) |
| 21 | 0.5080 (41.28) | 0.5080 (44.27) | 0.5080 (39.74) |
| 22 | 0.3048 (36.11) | 0.3048 (39.11) | 0.3048 (34.46) |
| 23 | 1.0160 (44.61) | 0.7620 (38.79) | 1.0160 (42.89) |
| 24 | 0.7620 (39.54) | 0.7620 (36.37) | 0.7620 (37.29) |
| 25 | 0.7620 (36.40) | 0.6096 (33.16) | 0.7620 (33.74) |
| 26 | 0.5080 (32.93) | 0.3048 (33.44) | 0.6096 (32.00) |
| 27 | 0.3048 (32.18) | 0.5080 (34.38) | 0.3048 (30.39) |
| 28 | 0.3048 (36.02) | 0.6096 (32.64) | 0.3048 (34.81) |
| 29 | 0.4064 (31.38) | 0.4064 (30.05) | 0.4064 (30.67) |
| 30 | 0.4064 (30.47) | 0.4064 (30.10) | 0.4064 (30.21) |
| 31 | 0.3048 (30.95) | 0.3048 (30.35) | 0.3048 (30.36) |
| 32 | 0.3048 (32.24) | 0.4064 (31.09) | 0.4064 (31.89) |
| 33 | 0.4064 | 0.5080 | 0.4064 |
| 34 | 0.5080 | 0.6096 | 0.6096 |
| Cost (\$ 10 ⁶) | 6.195 | 6.220 | 6.183 |

It is important to report that in all tested cases, Case Study 1 and Case Study 2, with the three distinct situations, all the works in the papers considered for comparison with our results use flow directions fixed a priori. Also, no pumps were considered in these case studies, but it is not a problem once it is considered in the MINLP model. In all cases, the computational time was about 10 min. If the flow directions are fixed or known a priori, this time decreases to about 2 seconds, using a computer with a 3.50 GHz Intel® Core™ i5-4690 processor with 8.00 GB of RAM.

5. Conclusions

In the present paper, a MINLP optimization model for the design of looped water distribution networks was developed, considering unknown flow directions. Strategies for avoiding nonlinearities in the equations were proposed and the resulting model has only two nonlinear equations. These strategies allow the use of the global optimization solver BARON in GAMS. Two case studies from the literature are used and global optima are obtained for the cases studied in all situations.

The proposed model also avoids the use of additional software to solve hydraulic equations once the pressure drops and velocities are calculated simultaneously with the network design. It is important to consider that the Hazzen-Williams equation is highly dependent on its parameters α , β and γ . Small variations in its values can lead to very different global optima, in terms of the network cost. The second case study was chosen with the objective of showing these discrepancies.

The optimal design of WDN is a complex problem and when the flow directions are not known a priori, this complexity is increased. However, with appropriate techniques, it is possible to linearize nonlinear equations and to avoid unnecessary complexities. In the current paper, all equations resulted linear, excluding two, which have exponential behavior and are well bounded, allowing the difficulties present in the Hazzen-Williams equation and the use of deterministic mathematical programming techniques, with the achievement of global optimal solutions. Also, it is important to remark that it is possible to solve hydraulic equations simultaneously in the optimization model.

Acknowledgments

The authors gratefully acknowledge the financial support from the National Council for Scientific and Technological Development - CNPq (Brazil), the Coordination for the Improvement of Higher Education Personnel - Process 88881.171419/2018-01-CAPES (Brazil) and the Spanish Ministerio de Economía, Industria y Competitividad CTQ2016-77968-C3-02-P (FEDER, UE).

References

- Abebe, A., Solomatine, D., 1998. Application of global optimization to the design of pipe networks. Proc. 3rd International Conference on Hydroinformatics, Copenhagen, 989–996.
- Alperovits, E., Shamir, U., 1977. Design of optimal water distribution systems. *Water Resources Research* 13(6), 885–900.
- Bi, W., Dandy, G. C., Maier, H. R., 2015. Improved genetic algorithm optimization of water distribution system design by incorporating domain knowledge. *Environmental Modelling & Software*, Elsevier, (69), 370–381.
- Bragalli, C., D'Ambrosio, C., Lee, J., Lodi, A., Toth, P., 2008. Water network design by MINLP. IBM Research Report RC24495(W0802-056).
- Costa, A. L., Medeiros, J. L., Pessoa, F. L., 2001. Global optimization of water distribution networks through a reduced space branch-and-bound search. *Water Resources Research*, Wiley Online Library, 37(4), 1083–1090.
- Cunha, M. d. C., Sousa, J., 1999. Water distribution network design optimization: simulated annealing approach. *Journal of Water Resources Planning and Management*, American Society of Civil Engineers, 125(4), 215–221.
- D'Ambrosio, C., Lodi, A., Wiese, S., Bragalli, C., 2015. Mathematical programming techniques in water network optimization. *European Journal of Operational Research*, Elsevier, 243(3), 774–788.
- Dandy, G. C., Simpson, A. R., Murphy, L. J., 1996. An improved genetic algorithm for pipe network optimization. *Water resources research*, Wiley Online Library, 32(2), 449–458.
- De Corte, A., Sørensen, K., 2016. An iterated local search algorithm for water distribution network design optimization. *Networks*, 67(3), 187–98.
- Eiger, G., Shamir, U., Ben-Tal, A., 1994. Optimal design of water distribution networks. *Water Resources Research*, Wiley Online Library, 30(9), 2637–2646.

- Ezzeldin, R., Djebedjian, B., Saafan, T., 2014. Integer Discrete Particle Swarm Optimization of Water Distribution Networks. *Journal of Pipeline Systems Engineering and Practice*, 5(1), 04013013-1 04013013-11.
- Fujiwara, O., Khang, D. B., (1990), A Two-Phase Decomposition Method for Optimal Design of Looped Water Distribution Networks, *Water Resource Research*, 26, 539–549.
- Geem, Z. W., 2006. Optimal cost design of water distribution networks using harmony search. *Engineering Optimization*, Taylor & Francis, 38(3) 259–277.
- Geem, Z. W., 2009. Harmony search optimisation to the pump-included water distribution network design. *Civil Engineering and Environmental Systems*, Taylor & Francis, 26(3), 211–221.
- Geem, Z. W., Kim, J. H., Loganathan, G. V., 2001. A new heuristic optimization algorithm: harmony search simulation, Sage Publications Sage CA: Thousand Oaks, CA, 76(2) 60–68.
- Geem, Z. W., Kim, J. H., Loganathan, G., 2002. Harmony search optimization: application to pipe network design. *International Journal of Modelling and Simulation*, Taylor & Francis, 22(2), 125–133.
- Goldberg, D. E., Kuo, C. H., 1987. Genetic algorithms in pipeline optimization. *Journal of Computing in Civil Engineering*, American Society of Civil Engineers, 1, (2), 128–141.
- Goulter, I.C., Lussier, B.M., Morgan, D.R., 1986. Implications of head loss path choice in the optimization of water distribution networks. *Water Resources Research*, 22(5), 819-22.
- Gupta, I., Gupta, A., Khanna, P., 1999. Genetic algorithm for optimization of water distribution systems. *Environmental Modelling & Software*, 14(5), 437– 446.
- Haghighi, A., Samani, H. M., Samani, Z. M., 2011. GA-ILP method for optimization of water distribution networks. *Water resources management*, Springer, 25(7), 1791–1808.

- Hansen, C. T., Madsen, K., Nielsen, H. B., 1991. Optimization of pipe networks. *Mathematical Programming*, Springer, 52(1-3), 45–58.
- Kadu, M. S., Gupta, R., Bhawe, P. R., 2008. Optimal design of water networks using a modified genetic algorithm with reduction in search space. *Journal of Water Resources Planning and Management*, American Society of Civil Engineers, 134(2), 147–160.
- Kessler, A., Shamir, U., 1989. Analysis of the linear programming gradient method for optimal design of water supply networks. *Water Resources Research* 25(7), 1469–80.
- Krapivka, A., Ostfeld, A., 2009. Coupled genetic algorithm linear programming scheme for least-cost pipe sizing of water-distribution systems. *Journal of Water Resources Planning and Management*, American Society of Civil Engineers, 135(4), 298–302.
- Liong, S.-Y., Atiquzzaman, M., 2004. Optimal design of water distribution network using shuffled complex evolution. *Journal of the institution of engineers*, Singapore, 44(1), 93–107.
- Loganathan, G., Greene, J., Ahn, T., 1995. Design heuristic for globally minimum cost water-distribution systems. *Journal of Water Resources Planning and Management*, American Society of Civil Engineers, 121(2), 182–192.
- Maier, H. R., Simpson, A. R., Zechin, A. C., Foong, W. K., Phang, K. Y., Seah, H. Y., Tan, C. L., 2003. Ant colony optimization for design of water distribution systems. *Journal of water resources planning and management*, American Society of Civil Engineers, 129(3), 200–209.
- Montalvo, I., Izquierdo, J., Pérez, R., Tung, M. M., 2008. Particle swarm optimization applied to the design of water supply systems. *Computers & Mathematics with Applications*, 56(3), 769–776.
- Montesinos, P., Garcia-Guzman, A., Ayuso, J. L., 1999. Water distribution network optimization using a modified genetic algorithm. *Water Resources Research*, Wiley Online Library, 35(11), 3467–3473.

- Morsi, A., Geissler, B., Martin, A., 2012. Mixed integer optimization of water supply networks, in *Mathematical optimization of water networks*, Springer, p. 35–54.
- Páez, D., Saldarriaga, J., López, L., Salcedo, C., 2014. Optimal design of water distribution systems with pressure driven demands. *Procedia Engineering*, 89, 839–847.
- Qi, X., Li, K., Potter, W. D., 2015. Estimation of distribution algorithm enhanced particle swarm optimization for water distribution network optimization. *Frontiers of Environmental Science & Engineering*, 10(2), 341–351.
- Reca, J., Martínez, J., 2006. Genetic algorithms for the design of looped irrigation water distribution networks. *Water resources research*, 42, W05416.
- Rossman, L. A., 2000. *EPANET 2 — User Manual*, National Risk Management Research Laboratory, Office of Research and Development, U.S. Environmental Protection Agency, Cincinnati.
- Sarbu, I., Borza, I., 1997. Optimal design of water distribution networks. *Journal of Hydraulic research*, Taylor & Francis Group, v. 35, n. 1, p. 63–79.
- Savic, D. A., Walters, G. A., 1997. Genetic algorithms for least-cost design of water distribution networks. *Journal of Water Resources Planning and Management*, 123(2), pp.67-77.
- Sawaya, N. W., Grossmann, I. E., 2007. Computational implementation of non-linear convex hull reformulation. *Computers & Chemical Engineering*, 31, 856-866.
- Shamir, U. Y., Howard, C. D., 1968. Water distribution systems analysis. *Journal of the Hydraulics Division, ASCE*, 94(1), 219–234.
- Simpson, A. R., Goldberg, D. E., 1994. *Pipeline optimization via genetic algorithms: From theory to practice*. Water pipeline systems, Mechanical Engineering Publication, London, p. 309–320.
- Surco, D. F.; Vecchi, T. P.; Ravagnani, M. A. S. S., 2017. Optimization of water distribution networks using a modified particle swarm optimization algorithm. *Water Science and Technology: Water Supply*, 18(2), 660–678.

- Surco, D. F.; Vecchi, T. P.; Ravagnani, M. A. S. S., 2018. Rehabilitation of water distribution networks using particle swarm optimization. *Desalination and Water Treatment*, 106, 312 - 329.
- Surco, D. F.; Macowski, D. H., Coral, J. G. L., Cardoso, F. A., Vecchi, T. P.; Ravagnani, M. A. S. S., 2019. Multi-swarm optimizer applied in water distribution networks. *Desalination and Water Treatment*, accepted for publication.
- Suribabu, C., 2010. Differential Evolution Algorithm for optimal design of water distribution networks. *Journal of Hydroinformatics*, 12(1), 66–82.
- Suribabu, C., Neelakantan, T., 2006. Design of water distribution networks using particle swarm optimization. *Urban Water Journal*, 3(2), 111–120.
- Suribabu, C.R., 2012. Heuristic-Based Pipe Dimensioning Model for Water Distribution Networks. *Journal of Pipeline Systems Engineering and Practice*. 3:115-124.
- Trespacios, F.; Grossmann, I. E., 2015. Improved Big-M reformulation for generalized disjunctive programs. *Computers & Chemical Engineering*, Elsevier, 76, 98–103.
- Van Dijk, M., Van Vuuren, S.J., Van Zyl, J.E., 2008. Optimizing water distribution systems using a weighted penalty in a genetic algorithm. *Water SA*, 34(5), 537–48.
- Vairavamoorthy, K., Ali, M., 2005. Pipe index vector: A method to improve genetic-algorithm-based pipe optimization. *Journal of Hydraulic Engineering*, American Society of Civil Engineers, 131(12), 1117–1125.
- Watanatada, T., 1973. Least-cost design of water distribution systems. *Journal of the Hydraulics Division*, 99(9), 1497-513.
- Zecchin, A. C., Simpson, A. R., Maier, H. R., Leonard, M., Roberts, A. J., Berrisford, M. J., 2006. Application of two ant colony optimization algorithms to water distribution system optimization. *Mathematical and computer modelling*, 44(5-6), 451–468.
- Zheng, F., Simpson, A. R., Zecchin, A. C., 2013. A decomposition and multistage optimization approach applied to the optimization of water distribution systems with multiple supply sources. *Water Resources Research*, 49(1), 380–399.

Zhou, X., Gao, D.Y., Simpson, A.R., 2016. Optimal design of water distribution networks by a discrete state transition algorithm. *Engineering Optimization*, 48(4), 603-628.

ACCEPTED MANUSCRIPT