

Planning and Operation of Low Voltage Distribution Networks: A Comprehensive Review

Mohammad A.A. Al-Jaafreh, Geev Mokryani

University of Bradford, Bradford, BD7 1DP, UK

Emails: M.A.A.Al-Jaafreh@bradford.ac.uk, G.Mokryani@bradford.ac.uk

Abstract: The low voltage (LV) distribution network is the last stage of the power network, which is connected directly to the end user customers and supplies many dispersed small-scale loads. In order to achieve environmental targets and to address the energy shortage issue, governments worldwide increase the renewable energy sources (RES) into the electricity grid. In addition, different types of low carbon technologies (LCTs) such as electric vehicles (EVs) are becoming widely used. A significant portion of RES and LCTs is penetrated into the LV distribution network, which poses a wide range of challenges. In order to address these challenges, there is a persistent need to develop traditional planning and operation frameworks to cope with these new technologies. In this context, this paper provides a comprehensive review about planning, operation, and management of LV distribution networks. The characteristics, types, and topologies of LV distribution networks plus different aspects of operation and planning are investigated. An insightful investigation of the reasons impacts and mitigation of voltage and current unbalanced in LV networks is provided. Moreover, the main three-phase power flow techniques used to analyze the LV networks are analyzed.

1. Introduction

Around the globe, the development of electric power industry experiencing essential changes and challenges in recent years [1]. A significant part of the energy demand is generated by fossil fuel resources, (e.g., Natural gas, crude oil) leads to significant increase in carbon emission to the atmosphere which is resulting in the environmental concerns, namely, global warming [2], [3]. The development of economics, and the rapid increase of population, resulting in the exponential rise in the energy demand, which implies energy shortage issue and even more greenhouse gas emission in the atmosphere [4]. During the period 1990 to 2007, the annual world energy demand increased by 1.3 % and is expected to increase by 48 % from 2012 to 2040 [5]. For instance, the energy demand in the UK is projected to increase by 4% by 2035 [6]. Therefore, many countries are in the process of implementing programs to address climate change and energy shortage issues. In order to proceed these programmers successfully, several corresponding policies are established [7]. Based on the Paris agreement various developed countries committed to reduce emissions of greenhouse gases (e.g., Carbon dioxide) [8]. The European Union agreed 20% reduction of greenhouse gas emission by 2020 in comparison with 1990 baseline [9]. Also, many countries obliged under the Kyoto protocol to reduce their greenhouse emission on average 50% by 2050 [10]. For instance, the UK government committed an 80% reduction of their emission under this protocol [11].

Based on obligations made by governments worldwide to achieve environmental targets and to address the energy shortage issue, the energy generation system experiencing a shift towards a more sustainable system [3]. These issues addressed by increasing the generation from renewable energy sources (RES) such as photovoltaic (PV) systems and wind, in the form of distributed generations (DGs). A significant amount of RES integrated and installed low voltage (LV) level [12]. In addition, the end-use consuming pattern is shifting towards low carbon technologies such as electric vehicles and electro heating systems [13]. This adds more challenges to the LV

network, where the scope of these challenges depends on the ability of an LV network to handle these changes. For instance, the LV networks have been traditionally designed assuming unidirectional power flow (from source to the consumer) with no consideration of the bi-directional power flow in presence of renewable energy generation. This poses several technical challenges such as voltage rise and thermally overloaded assets [14].

To overcome and address these challenges, and to improve the ability of LV networks to host more of RES, there was a persistent need to develop the conventional planning and operation schemas of the LV network to be adapted with the new technologies [4]. Moreover, various planning and operational schemes have been proposed by different researcher and research organization around the world. In this context, this paper provides a comprehensive literature review about the planning and operation of the LV distribution network. Starting with highlighting the main challenges facing the LV networks, which are posed by the high penetration of distributed RES. An insight, background on the main character and topologies of the LV networks with highlighting the key differences between LV networks and both high and medium voltage networks is provided. Moreover, the main LV networks planning and reinforcement frameworks that have been discussed in the literature, including both conventional and active network system schemas are investigated. Afterward, the operational and management of LV networks is discussed, which provides an insightful overview of the methods that have been used to analyze the unbalanced three-phase LV distribution networks.

2. Low voltage distribution networks

2.1. Introduction to transmission and distribution networks

This section presents an overview of LV distribution networks. A power system consists a set of interconnected parts to generate, transmit, distribute the electricity to the end user customers [7]. These parts are interfaced by a set of transformers to step up and step down the voltage level to the appropriate level, which is suitable for the system operation to

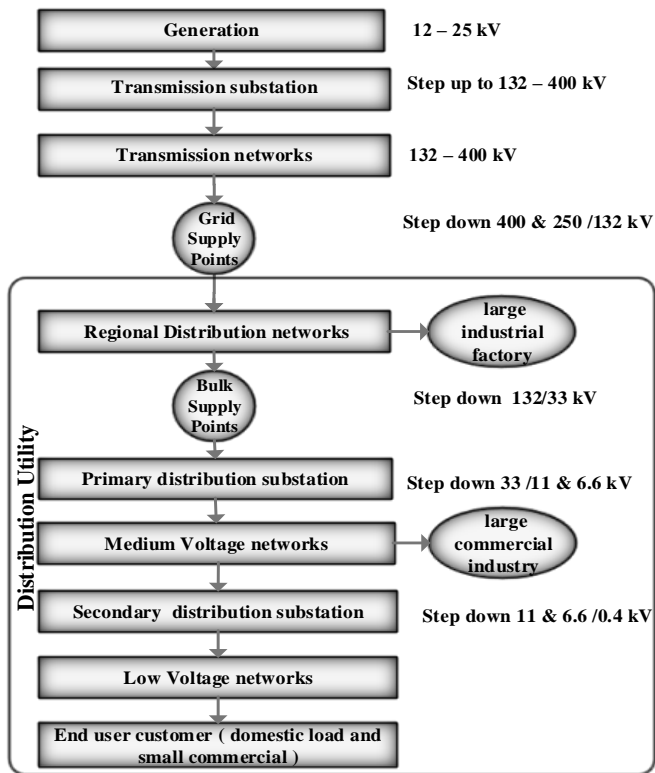

Fig 1. Electric power system structure in the UK adapted from [15] reduce the network line losses. The generation in the conventional system was only based on fossil fuel and located in a central location away from the load centers [14]. However, with the adoption of DGs, the electricity will be generated locally by both RES and other sources such as small diesel engine and fuel cells, and this has reshaped the conventional system topology toward decentralized the generation [4]. In the centralized power system, the power generated by the centralized large-scale power plant injected into the transmission network through a step-up transformer at high the voltage (HV) level (e.g. 132-400 kV in the UK) [16]. Then, the transmission network transport electrical power to the regional distribution networks through the Grid Supply Points (GSP), which step down the voltage level to the distribution voltage level (e.g., 132 kV in the UK). The distribution network delivers the power to the end user consumer through lower voltage distribution networks. Firstly, the voltage is stepped down to medium voltage (MV) level e.g. 33kV at Bulk Supply Point (BSP) and then to lower MV network (e.g. 11 kV) at primary substation. Finally, secondary distribution substation steps down the voltage into the low voltage level required to supply the single-phase and three-phase end users (230V single phase and 0.4 kV Three-phase). In other words, the MV networks start after the BSP and terminate at a secondary distribution substation. In addition, the LV networks start from the secondary distribution substation, where the voltage level stepped down to 0.4 kV between two lines of the three-phase networks. Thus, the electricity is distributed to the single-phase end-user through the LV networks (230 V line to neutral), [15–17]. Fig.1 summarizes the power system structure in the UK [15].

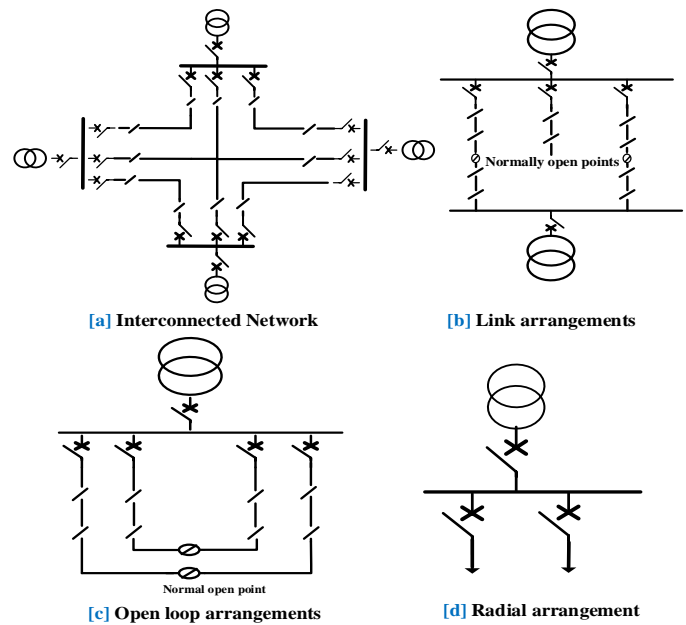

Fig 2. The main topologies of power networks [16], [17].

2.2. Transmission and distribution networks topologies

There are three main configurations of electrical power networks as shown in Fig.2, [15], [17].

- **Interconnected network topology** is adopted in HV transmission networks to provide a secure power supply in the event of an outage, as there are multiple paths to transmit electrical power.
- **Ring topology** Includes both link arrangement and open loop which is mostly used in 11 kV and 33 kV MV networks to provide more secure supply as well. The open point is located between two interconnected radial feeders to ensure the radial operation for each feeder to isolate a faulty section.
- **The radial network topology** is widely used in LV distribution networks where faults occur infrequently and the fatality level of the fault (the number of consumers affected by the fault) is not high. The radial network can be reconfigured to *weakly meshed* interconnect two buses in the network.

2.3. Definition of LV distribution networks

Based on the British standards the LV networks are defined as a network with a maximum limit of voltage level 1 kV [18]. Moreover, around the world, the most common voltage levels of local LV networks are within the range 120-240 V single phase (i.e. Phase to neutral), or 208-415 three phases four wires (3-phase 4 wire) [19]. Based on the international standard recommendation (IEC 60038), the voltage level of 3 phase-4 wire is 230/ 400 V [19]. The LV network is the last stage of the power network, which connected directly to the end user customers and supplies many dispersed small-scale loads [20]. Thus, it has the characteristics of small individual capacity, but a massive number of nodes. Due to the low voltage level, installation and development of LV feeders require lower finance compared with higher voltage feeders such as MV and HV [21]. However, the huge number of LV feeders requires a significant amount of work might consume most of a utility's capital [22].

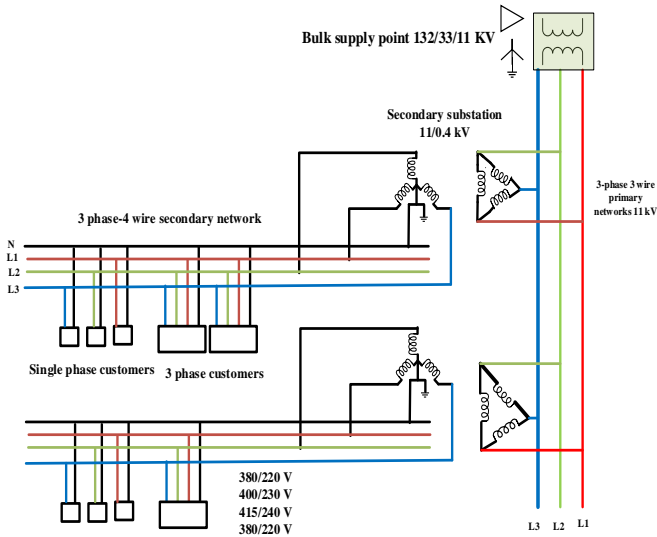

Fig. 3 Typical European distribution system layouts [19] [23]

Table 1. Catachrestic of LV feeders in the UK [24]

Area		Urban	Rural
Feeder number per transformer	Minimum	2	1
	Medium	6	3
	Maximum	16	6
LV feeder length (m)	Minimum	10	100
	Medium	100	250
	Maximum	200	600
Total line length per transformer (m)	Minimum	150	500
	Medium	450	1600
	Maximum	900	3200

2.4. LV networks Layouts in Different Regions

Around the world The LV network system has structured into various forms, among them, the “European” and “American” layouts are the most widely used layouts in European countries and Central and North of America[22],[25].

2.4.1. The European LV networks layout: “European” layout of LV networks used by most countries in Europe. For example, The LV network in the UK is three phases four wire system supplied from a three-phase MV/230/400 V distribution transformer [19]. Where 230/400 refer to a secondary voltage level, 400 V line to line and 230 V line to neutral (nominal voltage or RMS)[18]. The circuit diagram of a distribution network in the UK is illustrated in Fig.3. In this schema, each MV/LV distribution substation can supply a various number of 3 phases- 4 wire LV feeders. Moreover, the LV feeder can carry the power efficiently up to 300 meters approximately [22]. In Other words, at low voltage levels (400 V), each substation can supply an area corresponding to a radius of 300 meters from the substation, which makes it suitable for high load densities areas[23]. Based on the practical application the LV feeders can be underground cables or overhead lines extended from the secondary distribution substation. Most LV feeders in the UK are designed as multi-phase feeders, which consist of 4 wires (3 phase and neutral)[22]. Table 1 summarizes the catachrestic of LV feeders in the UK in both urban and rural areas [24].

2.4.2. The American LV networks Layout: The American LV networks Layout illustrated in Fig 4 [23] [25]. The layout

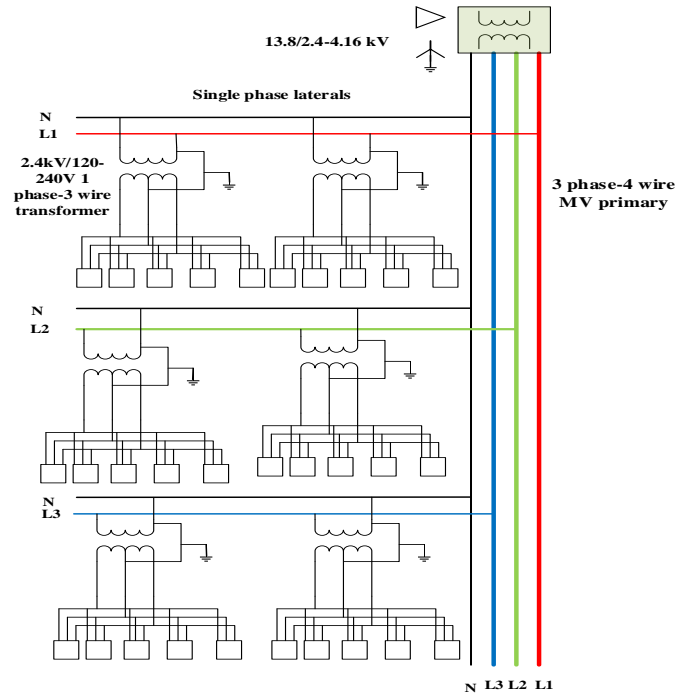

Fig.4 Typical American distribution system layout [19] [23]

differs significantly from the European layout, where the three-phase LV networks are practically nonexistent. And the system is effectively carried out the power through three phase’s four wire (3-phase and neutral) MV networks [19]. The MV network system supplies numerous number single phase transformers which connected through many single phases (phase and neutral) primary laterals [25]. The secondary windings of single-phase transformer are center-tapped to produce single phase three wire supply, 120 (line to neutral) 240 V (line to line). As a result, capacity rating the single-phase MV/LV secondary transformer is much smaller than those in the European system and the LV feeders are minimized [23]. The main advantage of this layout is that the load density supplied by each substation and its installation capital cost is lower than that in the European system. However, the low voltage level (120 V) at the secondary side of the single - phase transformer is about half of the European single-phase secondary voltage (240 V), which lead to some technical issues and barriers. For instance, it limited the extension of the single-phase feeder which only has the ability carry the power efficiently up to 60 meters from the substation [25]In addition, the level of power losses and voltage drop-in single-phase LV feeder is much higher than that in the three-phase LV feeders[21].

Both ‘European’ and ‘American’ layouts are widely adopted in many countries around the world outside Europe, Central America and North America [25]. Moreover, in some region, the distribution system layout is a mixture of European and American [25]. Table 3(in Appendix),Fig.5 and Fig.6 provide a summary of the voltage level of local LV networks and their associated schematic diagram in different countries around the world [19]. From Table.3, Fig.5 and Fig.6 it is illustrated that the European system (Fig.5 (a) and (b)) is the most adopted system around the world. However, the American system (Figs.6 (c), (d), (e), and (f)) is adopted in North America, Latin America, and few countries in Asia and the Middle East

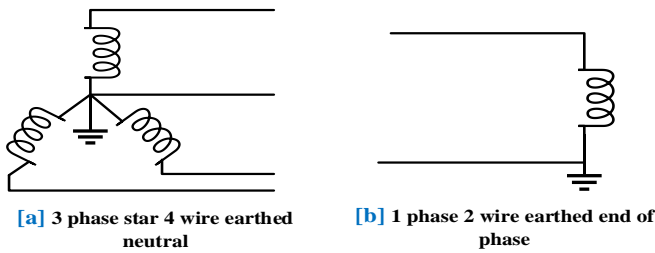

Fig. 5 Circuit diagram of LV networks around the world (associated with European layout) [19]

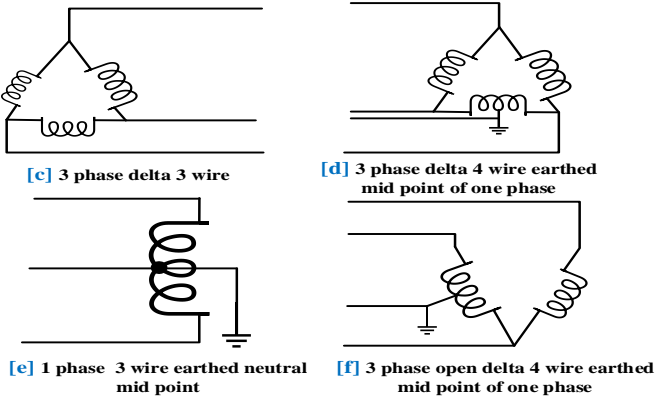

Fig. 6 Circuit diagram of LV networks around the world (associated with American layout) [19]

such as Saudi Arabia. Moreover, some countries mixed between the European layouts and American layouts such as Iran and South Korea [19].

2.5. LV network topologies

The investigation in the main topologies used to configure the LV distribution networks shows that most LV networks are configured as radial networks due to the simplicity of analysis and protection system design [22]. However, due to the advantages of the loop or Ring, or mesh configuration to mitigate some of the technical issues such as voltage variations and reverse power flow; the use of mesh configuration is becoming more common [26, 27]. As mentioned in the previous section, most LV networks are following the European layout. So, the three-phase 400 LV secondary circuit is basically designed based on the circuit diagram shows in Fig. 5-a, which is 3 phase- 4 wire circuit underground cables or overhead lines suspended from, concrete, metal, or wooden poles [28][19]. Due to high load and housing density in urban areas, the underground cable is utilized usually in LV network construction [23]. Using the underground cable improve the possibility for the LV cables from the neighboring substation to terminate close to each other, which permit simplicity and low cost joining them together (interconnected) using the underground link box [22]. Therefore, interconnected the surrounding substations to each other called **looped or meshed or ring network arrangement** as that shows in Fig. 7-a [28][29]. The chief advantages such arrangement is improving the reliability and the security of supply, as well as improve the system flexibility, for example, in case of shutting down or suddenly losing the connecting of one substation, the power can be supplied normally to the load by the surrounding substation via the link box, [30]. Also, loop topology has proven its ability

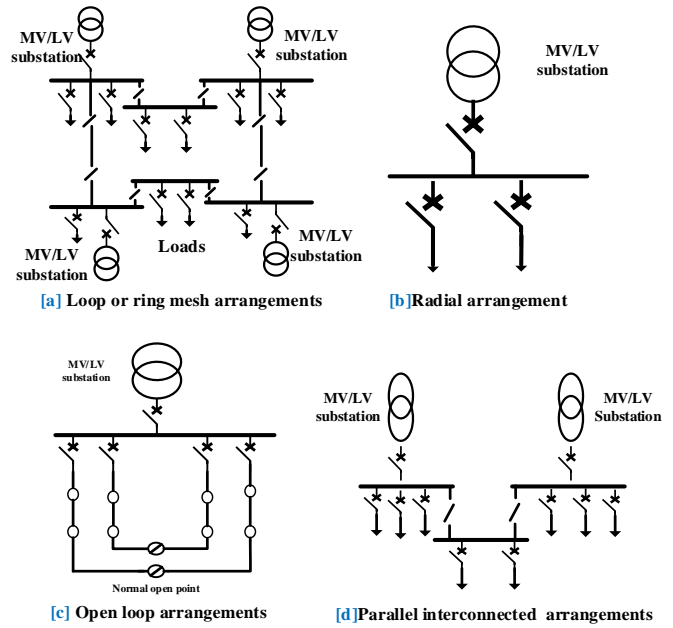

Fig. 7 LV network topologies

to improve the system hosting capacity for Distributed Generators (DGs) such as photovoltaic systems, which helps to mitigate the technical issues such as voltage rise and reverse power flow [27]. However, In rural areas, where the load density with highly separated uncritical loads, the **radial arrangement** found to be the most economical and with a low level of faults and simple protection schema as shown in Fig. 7-b [23],[24]. Despite the fact that the radial topology is widely used in 400 V 3phase- 4 wire LV networks, it has the lowest level of supply security and reliability, with the absence of flexibility [22] In order to increase the level of reliability of two adjacent radial systems which they served from the same substation [19],[22]. These feeders can be interconnected via a normally open point to supply to ensure the radial operation of each feeder, where the location of the normally open point can be moved following the occurrence of the fault to isolate the faulty section with maintaining the supply for the rest of the faulty feeder [22]. Such arrangement is also called **ring open loop topology** as shown in Fig 7-c [30]. Moreover, **parallel interconnected configuration or spot topology** can be used by interconnected two adjacent LV radial feeder supplied from two different substations as that shows in Fig 7-d [22], [31]. Such configuration improves the system reliability and flexibility in case of a maintenance event, where the loads may still supply by the other transformer [19].

2.6. The main characteristics of the low voltage distribution network

Based on the above investigation the main characteristic of the LV distribution network is listed as follows:

1. **Consist of a large number of nodes:** The LV network is to supply many consumers. For example, in the Dutch power system, the network has more than 99.6% of the whole system connections as that illustrated in Fig.8 [32].
2. **Usually, the network is not monitored:** a significant part of the metering system, particularly the household meter still without communication possibility. The advanced metering

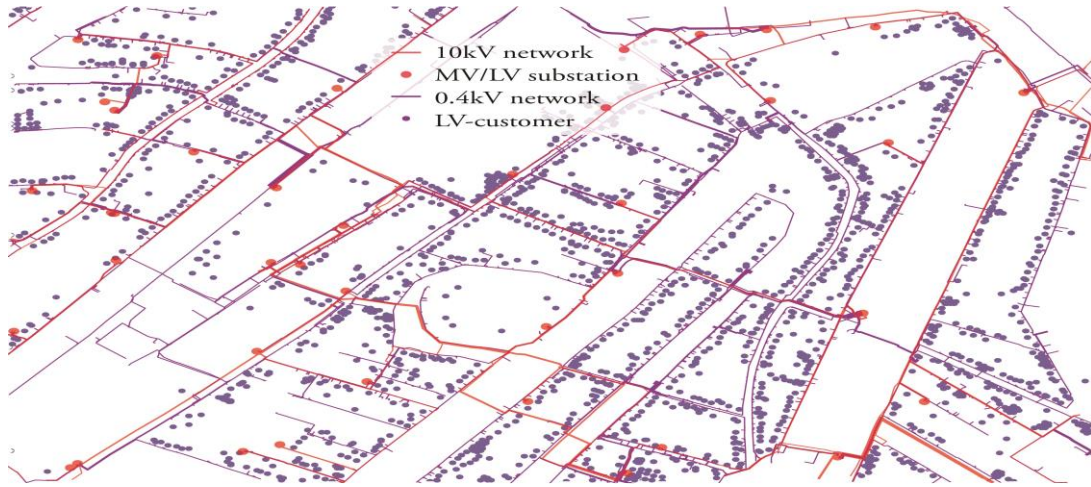

Fig 8. Part of LV network in the Netherlands [32]

infrastructure (AMI) is still in the early stage of the installation. And this leads to the lack of understanding of the real state of the LV network, which resulted in a wide range of uncertainties.

3. **Operated in radial or weakly meshed topology:** the majority of LV is radial nature, and this simplifies the power flow analysis
4. **High R/X ratios compared with HV and MV networks:** especially in the case of underground cable. And that makes the resistance a very important factor in determining the voltage, where the voltage angle approximately constant at the LV network.
5. **Highly violated load pattern:** the load pattern is unbalanced with a high level of uncertainty.
6. **Untransposed feeders:** The spacing between conductors is non-symmetrical and the transposition principle does not apply compared with HV and MV networks.
7. **Bi-directional power flow:** The distribution generator injected the excess generated power into the LV network, which resulted in reverse power flow from the load side, and this raises the voltage level in the load side.

3. Unbalanced voltages and currents in three phase LV networks: Reasons, impacts and mitigation

3.1. Introduction to voltage and current Imbalance in LV networks

In the power system, a three-phase system, or networks considered as balanced or symmetrical if two conditions are verified. **The first condition** is: the voltages and currents in the three phases have the same magnitudes. **The second condition** is: the phase shift angle with respect to each other or between consecutive phases must equal to 120 degrees [33]. However, for different reasons related to the operation and planning of the LV networks, Practically LV networks are considered as unbalanced or asymmetrical [24]. The unbalance describes the LV network conditions, in which the voltages and current magnitudes in the three phases are not equal. Also, the phase shift angle between two adjacent phases not precisely 120

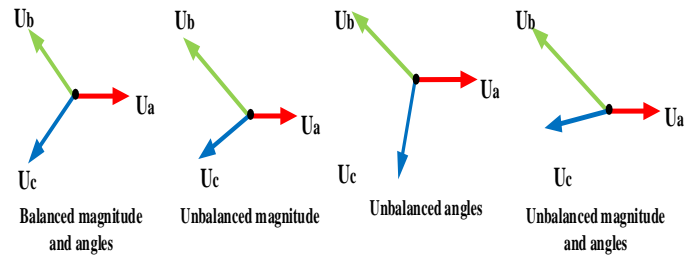

Fig.9 Voltage and current phasor diagram for balanced and several unbalanced 3 phase systems [34]

degrees. Fig.9 provides a phasor diagram to compare the balanced three-phase system (ideal condition) and various unbalanced conditions [34]. Where U_a , U_b , and U_c refer to the voltage or current phasors in the system. The chief reasons for voltage and current unbalance in LV networks are an uneven distribution of single-phase customers among the three phases and the load variations, which might happen normally or because of the high penetration of low carbon technologies, either DGs such as residential PV systems or new smart loads such as electric vehicles EVs [21].

3.2. The relationship between current and voltage unbalance conditions

Based on Ohm's Law the network impedance is the connection between current and voltage. In three-phase networks, the network impedances might be either symmetrical or asymmetrical[35]. However, in both cases, the network impedance connects between voltage unbalanced and current unbalance. The symmetrical network is defined as networks with equal self and/or mutual impedance [35]. In three-phase LV networks, the impedance of the system component in each phase is rarely the same[22]. The overhead LV networks lines impedances values are always not equal, due to the dependence of phase impedance on the distance to the ground and the distance from the line to line which are normally not equal[22]. For instance, the central line in three phases four wire LV

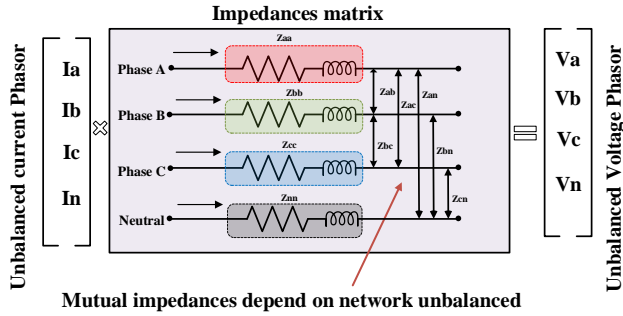

Fig. 10 The relationship between current and voltage unbalance overhead networks, the impedance of the central line is approximately 6-7% lower than the two outer phases impedance [24]. Moreover, in underground LV networks, many of LV feeders comprises of a mix of cables types, which resulted in unequal impedance among the three phases. Also, using a four-core cable design lead to unequal impedances between phases and between phases and neutral [34]. In addition, the asymmetrical transformer winding impedances cause impedance imbalance in LV network [36]. Fig.10 illustrated the network impedance and the relationship between current and voltage unbalance.

3.3. Reasons for voltage and current unbalanced

3.3.1. Uneven distribution of single-phase loads: Usually in MV and HV networks, the three-phase connected loads are balanced. However, most loads supplied by LV networks are single phase [22]. Thus, the load balance between the three-phase is not an easy task to be implemented. At the planning stage of LV networks, the network planner paid much effort to connect an equal number of customers in each of the phases aimed at making the load level balanced among the three phases [23]. However, in practical life, phase load balancing cannot be granted due to human behavior. To connect the single-phase consumers three phases four wire LV network, each customer needs to be connected to two wires, phase (one of the three-phase lines) and neutral. In practice, the electricity technicians tend to use one of the two lines closest to the neutral wire in LV underground cable, while ignoring the wire diagonally opposite to the neutral [34]. Also, in the three-phase vertical formation overhead lines, the worker technicians tend to use one of the two lines closest to the neutral wire. Fig.11 provide an example for three-phase four wire LV feeder with uneven distribution for single phase loads [34].

3.3.2. Variations in load demands: Normally the load demand of single-phase customer is changed with time depending on the type of appliances are used at that time. The impact of load variations on the accumulated demand per phase, becoming more noticeable when the numbers of customers connected to the feeder are low. Most likely that happen in rural LV feeders. On the other hand, in urban LV feeders with a high number of consumers the variation of individual customer load demand generally has a low impact on the accumulated demand per phase [22]. However, applying energy saving schemas like adjustable speed drive might increase the level of load variation, which can lead to non-balance between phases [37].

3.3.3. Propagation from the MV network: Generally, the unbalance voltage is not significant at the MV networks. However, the unbalanced voltages at MV networks interpreted

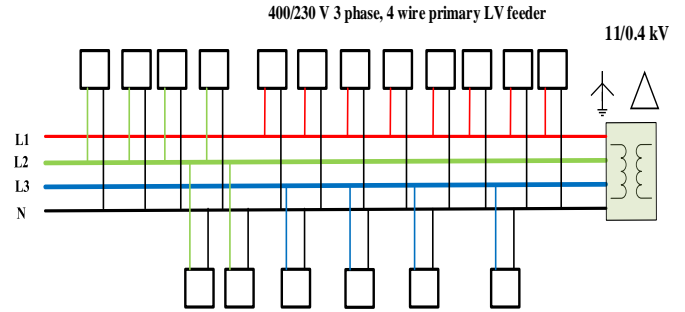

Fig.11 Uneven distribution of single load consumers through the windings of the MV/LV distribution transformer to the LV networks. And that might lead to changes in phase to neutral voltage at the secondary side of the transformer (LV side), which reflect the phase current on LV feeder [22].

3.3.4. Asymmetrical network impedances: As discussed before, the voltage and current unbalance are related to each other through the network impedances. If the network impedances (cable Impedance and MV/LV transformer impedance) are non-systematical, voltage unbalance might occur even though the currents are balanced [35].

3.3.5. High penetration of LCTs in LV networks: the word Low Carbon Technologies LCTs is associated with any kind of technologies installed in the electric networks and used by the end user customer aimed at cutting the level of carbon emission into the atmosphere [20]. LCTs includes renewable DGs such as PVs and end-user smart technologies such as EVs, heat pumps and Compinged Heat and Power (CHP) [36]. As discussed before, to achieve the carbon emission reduction targets, the use of LCTs has becoming more popular [38]. Installing these technologies at the LV networks feeder will increase the current and voltage imbalanced levels because of:

Increase the level of load demands variations: As discussed above the demand variation of the individual customer can influence the accumulated demand at each phase. So, using similar LCTs by a group of single-phase customers in parallel will add greater impact the accumulated load profile of the phase which they are connected [39]. Generally, the LCTs have a high current rating and longer operating time compared with the traditional appliance. Single phase high current rating appliance will take the highest share of the total current seen in the phase at which they are connected [38]. Therefore, use of these technologies at a specific time can lead to highly violated load demand at a given phase of LV feeder, which resulted in influence the current unbalance. Moreover, using LCTs for a long time, increase the probability of coincident usage. Therefore, the insufficient group usage of these technologies influences the load profile. For example, the customer tends to charge their EVs at night to use them in the morning [38].

Uneven distribution of single phase LCTs: The uneven placement of single phase LCTs will lead to current and voltage unbalance. For instance, uneven distribution of single phase DGs resulted in a high fluctuation of load profile each phase (Unbalanced). Moreover, due to the stochastic nature of renewable DGs, high penetration of this technology in a specific phase will lead highly fluctuated demand profile. In addition, using a mix of LCTs along the LV feeders might result in

unpredicted increasing and decreasing the demand, consequently a significant increase in the current [40].

3.4. *The impacts of voltage and current unbalanced on LV networks*

3.4.1. *Ineffective utilization of the network assets:* In three-phase LV feeder the total load demand of the feeder is unevenly distributed among the three phases. As a result of unevenly distributed of load demand among the three phases, some phases will be heavily loaded, especially with the future increasing of demand. On the other hand, the other phases are still not utilized efficiently. Hence, the heavily loaded phase conductors will need to be maintained or replaced, while the other phases are not [34]. Moreover, the three-phase equipment such as three-phase underground cables and the transformers are generally designed as one package. So, if one of the phases fails, the whole equipment must be replaced [22]. Indeed, the installed capacity of transformers or cables will never fully be utilized.

3.4.2. *Increasing in neutral and ground currents:* In the three-phase four wire LV networks, the neutral conductor is the return path of any out of the balanced current. Therefore, in ideal conditions, the neutral current is zero, which mean that the network is symmetrical or balanced. However, in practice, the amount of current in the neutral in LV network cannot be zero. The neutral current increase when the out of balance level is increased. In other words, in the unbalanced LV networks, the neutral current will rise significantly [41]. As a result, the neutral conductor, will thermally be overloaded specially if its rated capacity is lower than that for phase conductors. Moreover, if the level of the network out of balance is becoming larger, the ground current is becoming larger as well. The ground current depends on the neutral conductor, and earth pass impedance. Such conditions will pose some safety issues [34].

3.4.3. *Thermal overloaded of the network's assets:* The energy losses depend on the square of the currents pass through the conductors. In a symmetrical or balanced network, the current flowing through the three-phase is balanced and the neutral current is zero[42]. However, when the out of balance level among the three-phase, becoming higher, the current pass through the neutral and some phases conductors increase. Therefore, the thermal overload in the transformer and cables or overhead lines become larger, resulted in reducing the useful life of these assets due to the additional thermal stress on insulations (e.g. Transformer winding insulation, transformer oil, underground cable insulation) [43].

3.4.5. *Phase-neutral voltage displacement:* In out of balance conditions, a considerable amount of current flow through the neutral conductors. In such case, the neutral voltage is shifted (increased or decreased). If the neutral voltage becomes positive, the phase-neutral voltage of one phase decrease while the phase-neutral voltage of the other two-phase increase. However, if neutral voltage becomes negative, the phase-neutral voltage of one phase increase, while the phase - neutral voltage of the other two-phase decrease [34]. If the single phase voltage (e.g. 230) shifting outside the accepted limit (e.g. $\pm 5\%$), this will add risk on single phase consumer appliances. In addition, unbalanced conditions can result in a massive voltage drop on the heavily loaded phases, which

resulted in a decreasing phase to neutral voltage. On the other hand, the phase -neutral voltage for the lightly loaded phase will increase.

3.5. *Mitigation the effects of Voltage and current unbalanced*

Different methods have been used to mitigate unbalance effects. Indeed, these methods are discussed as follows:

3.5.1. *Phase and load balancing:* the most basic mitigation method to reduce the out of balance level in the LV networks are to rearrange the loads (currents) to more evenly distributed conditions among the three phases. Phase balancing is associated with rearranging the single-phase transformer connection to the MV level. Load balancing is associated with rearranging the single-phase customer connections along the three phase LV network. The conventional approach to achieve this is called manual trial and error approach. In this approach, a lot of field measurement and analysis are required to assess the network state to determine which phase is heavily loaded and which phase is lightly loaded in order to rearrange the customer connections. It was reported in [44] and [45] that the manual trial and error method is rarely succeeding to reduce the unbalance level. However, different automatic approaches have been developed based on power flow and optimization techniques. The common objective of these methods is evenly rearranging the load demand aloe the three phases to mitigate the unbalance effects.

3.5.2. *Network reconfiguration:* The network reconfiguration is defined as the changing the structure of the network feeders by changing the state of tie switches and sectionalizers [46]. The common objective of the network reconfiguration is to reduce the losses by transferring load from the heavily loaded section to lightly loaded sections. However, networks reconfiguration is also used to reduce the voltage unbalance through reducing current unbalance [47]. The LV network configuration can be achieved manually the or automatically to transfer the load aimed at reaching more balancing state. Different network reconfiguration approaches have been proposed in [46–48] with a common objective which is load balancing along the three phases.

3.5.3. *LV distribution network reinforcement:* Traditionally, voltage and current imbalance in LV networks are mitigated by the conventional network reinforcements such as improving a fedder lines cross section and install addition feeder. The references [49], [50] presented a voltage imbalance mitigation studies using traditional reinforcement methods.

3.5.4. *On load tap changer OLTC and Automatic voltage regulators:* traditionally the OLTC is applied on HV/MV transformer to control the voltage by controlling the ratio between the primary and secondary winding of the transformer. Due to its high cost, the MV/LV transformer is equipped with off-load tap changers. However, the use of OLTC in MV/LV transformer can provide more flexibility to reduce the networks, voltage imbalance as reported in [51] [52] [53].

3.5.5 *Voltage injection (DC/AC inverters):* the voltage unbalance can be mitigated by injecting additional voltage to compensate the unbalance among the three phases. This voltage is generally generated by the DC/AC inverter circuit.

References [54] and [55] studied the application DC/AC inverter.

3.5.6. VAR or reactive power compensation: Is usually used to control the voltage in a power system by adjusting the circulation of relative power among the generator and loads. The different researcher has studied the application VAR compensation in three phase LV networks such as [56–59]. A common conclusion among them is that the VAR compensation is helping to mitigate the current and voltage imbalance.

3.5.7. Load balancing transformer: is a new version of a distribution transformer with a special winding configuration. The special winding configuration help to achieve better current sharing on the primary side of MV/LV distribution transformer the in the case of supplying unbalanced loads. As a result, it improves the utilization of transformer capacity and mitigates the propagation of current unbalance from MV to LV side. A detailed description of the load balancing transformer is provided in the references [60–62].

3.5.8. Static Balancer: A detailed explanation of how this device can be used to mitigate the effects of current and voltage is provided in the reference [34].

4. Planning of Low Voltage Distribution Networks

The planning for the distribution system comprises of three main areas, the long-term strategic planning, network planning, and construction design. The long-term deal with the future major investment such as (system reinforcement or expansion planning). While the network planning deals with individual investment in the future, such as installing a new feeder or MV/LV substation. The construction design covers the structural design of each component in the network taking into account the available technologies and materials [17]. Power distribution planning including both technical and economic objectives. Typically, the main objective of LV network planning is to find the most economical solution, size, and location of the newly installed equipment subjected to a set of technical constraint. For example, sitting and sizing of new feeders or substation to meet the future demand [63]. Based on the planning methods, there are two eras of the planning which is deterministic “**Fit and Forget**” conventional approach and Active Distribution System (ADS) approach [64]. The main advantage of the ADS approach over conventional planning approaches is handling the high level of uncertainty pose by high renewable DG and the load varies. In the last decade distribution networks planning is becoming more complicated with high penetration of renewable and nonrenewable DGs technologies [63]. Planning function for such system includes three main factors: type of technology, the optimal size, and location to be installed in the network.

The challenges related to the high penetration of DGs into the LV networks have been studied and assessed by variety of innovative methodologies which adopted the smart grid (SG) technologies aimed at reducing the impact of challenges. For instance, Microgrid is becoming a proper solution for improving the networks DGs hosting capacity [65]. Indeed, a big effort has been paid towards improving the concept of Microgrids[65, 67–69, 72, 73].The conventional power system structure is experiencing a significant change. Therefore, different approaches have been studied heavily in the current

Table 2. Objective of Planning

References	Objective type
[74–76, 78, 80–83, 85, 86] [87–91, 93, 94] [96, 99, 101, 103, 104]	Economic <ul style="list-style-type: none"> • Minimization investment and operation cost • Minimization of line losses • Maximization of net profit value
[78, 87, 105–108, 110] [88, 111–116]	Technical <ul style="list-style-type: none"> • Maximization of system reliability • Improvement of voltage profile
[81, 91, 103, 117–119] [120–122] [123–126]	Environmental and social <ul style="list-style-type: none"> • Minimization of CO₂ emission • Maximization of renewable DG • Maximization of social welfare

literature such as demand response (DR) [69],[94], virtual power plants (VPPs) [77, 79], improved optimization methods for DGs planning and operations [7, 75, 81, 84, 96, 117, 120, 186], active distribution systems (ADS) as an operation methodology for the smart grids, which has been studied in [63, 63, 66, 119, 122]. These papers established new methodologies which can handle the changes posed by moving towards a smart grids and/or smart cities. Also, different requirement that needed to enable adoption of such technologies including information communication system (ICS), smart meters, Internet of Things (IoT), Big-Data Systems and control strategies as highlighted in [92, 95, 97], [98, 100, 102]. In addition, the impacts of adoption of different technologies such as on load tap changer (OLTC) have been studied recently in [51, 52, 88, 109, 116, 129, 130, 138].

The planning of the distribution network has caught attention in the several published papers. In [63], the authors analyze the key features of ADS planning based on a different aspect such as DG sitting and sizing, coupling planning and operation and the uncertainties aimed at developing appropriate models and methodology for the planning of ADS. To achieve that a comprehensive literature review analyzed and categorized based on the objectives, system constraint, the methods, then providing critical analysis and discussion of the key issues and challenges faces the adoption of ADS scheme. Also, several important research areas for future research has been provided. In [66] the authors developed a probabilistic planning power flow approach for LV network by using a Gaussian mixture distribution in load modelling. The effectiveness of the method evaluated by implementing a case study on the LV network with higher PV penetration. The results showed that the proposed method is highly accurate with low computational time. Moreover, A hybrid optimization method based on Genetic algorithm and sequential quadratic programming for sizing and sitting on a battery storage system (BSS) in unbalanced LV networks are proposed in[68].In addition, a planning method for placement and sizing BSS in LV networks hosting high PV is proposed in[70]. The effectiveness of the proposed method provided by carrying out a case study. The results showed that the improved method help to reduce the overvoltage and energy losses by preventing the reverse power flow as well as a significant reduction in total

investment costs. [71] developed a planning method for MV and LV radial distribution networks aimed at minimizing the investment cost subjected to operational constraint and reliability index. The method is applied in radial LV network comprises of 410 buses. Where the results indicated the importance of using an integrated planning technique for LV network planning rather than using sequential or hierarchal planning techniques.

4.1. Objectives of the planning

The objective function that is mainly used for the distribution system planning can be classified into economic, technical and environmental illustrated in Table 2. The optimization problem of distribution network planning can be formulated with a **Single Objective** or **Multi-Objective** function. However, the multi-objective model can be transformed into a single objective model by application of the weight coefficient method or Pareto-based method [7]. Moreover, the planning, optimization problem can be formulated in **Bi-Level**, which used to incorporate the operational aspects into the planning model [63].

5. LV Network reinforcement and/or expansion planning

The reinforcement of the low voltage network is becoming essential when the LV network cannot handle the operational issues raised by the high penetration of renewable resource. The LV networks need to be reinforced when it starts operating beyond the allowable current and voltage limits.

5.1. The Traditional Approach of LV Network Reinforcement

The traditional reinforcement planning approach for the LV network is practically straightforward. The recent approach for low voltage network planning based on minimizing the total investment cost and the cost of energy losses. The cost is evaluated based on a simple deterministic load curve pattern (Peake load demand) with applying as a specific factor for load growth with analyzing the scenario over the period of 20- 40 years of time [32]. The conventional choices of reinforcing the LV-network, including installing a new feeder, improve the capacity of the existing feeder lines by replacing the network lines or part of the cable, and adding a new substation or upgrade the capacity of the existing one. Authors in [101], [105], implement a distribution network expansion studies for the existing feeder expansion. In [101] proposed a multistage active distribution planning model aimed at long-term planning for the network feeder with the application of energy storage system.

In [105], the authors implement an expansion to overcome contingency conditions in the network feeders using a multistage evolutionary algorithm. The objective function aimed at improving the overall system reliability and efficiency of the radial distribution network by using a load-loss index. In [85] the authors also implement a multistage distribution network expansion using particle swarm optimization method to solve the AC power flow after sitting energy storage system aimed at shaving the peak load. The proposed method was evaluated using the IEEE 30-bus radial test network, the result showed a significant minimization of the planning, cost as well as improvement in the line loading capacity and the voltage bus. In addition, many other researchers have studied the expansion

planning of the distribution network in [75, 78, 82, 83, 118, 122, 127].

5.2. Adoption of Smart Grid technologies for LV network reinforcement

5.2.1. *Application of On Load Tap Changer: (OLTC)* High penetration of renewable DGs into LV distribution networks may result in the absolute magnitude of the voltage deviations (because of bi-directional power flow). To manage the voltage deviation, the active network management (ANM) scheme as a new smart grid technology can be utilized to control the bi-directional power flow. As a part of the ANM scheme, an On-Load Tap Changer (OLTC) can be installed on the MV/LV secondary substation [128]. OLTC enables the ratio between the corresponding primary and secondary voltages to be adjusted to achieve a certain voltage [129]. In fact, the majority of conventional MV/LV transformers equipped only with of-load tap changer [129]. Therefore, the use of an OLTC in the LV network considered as a smart grid concept, which shows a promising advantage to reinforce the LV networks [130]. Indeed, a framework to evaluate the application of OLTC within the planning process is required.

Some studies have analyzed the advantages of OLTC in distribution networks. However, a few studies have discussed the application of OLTC in the planning of LV networks. In [128] Nijhuis et al investigated the incorporation of OLTC in LV networks. The OLTC application has been considered into the optimization problem of planning by the introduction of additional voltage constraints. The result of the case study proved the effectiveness of the OLTC to reduce the impact of DG compared with the conventional reinforcement methods. Also, the application of OLTC in the planning and design of LV networks has been investigated in [129]. Moreover, in [131] the authors have evaluated the effectiveness of using the OLTC-fitted transformers in LV networks by implementing techno-economic analysis for real LV network in Germany. The result shows that using OLTC increase the LV hosting capacity of LV networks for PV.

5.2.2. *Application of Demand Response (DR):* Demand response (DR) is considered as a promising solution for the issues of the uncertain and fluctuating power supply, as the potentially significant flexibility of electrical demand can be utilized to provide the required power system services reduce the impact of RER [132]. In the context of LV network reinforcement, in [124] the authors applied the DR scheme on real distribution networks in the Netherlands. The result illustrates that applying DR program resulted reduce the requirement for the conventional network reinforcement. [133] applied centralized DR approach as an alternative to resolve capacity issues in LV feeder to avoid of costly improvement in existing feeder capacity. Ref [94] has improved long term planning method for LV networks based on the price based DR and DGs. The results showed a significant reduction in technical losses.

6. Operation of LV Distribution Networks

The operation of the LV distribution networks is covered power quality and network safety issues. These issues usually resolved by applying a type of management or control on the network. For instance, many studies have been implemented to

analyze the impact of DGs on LV operation. Also, the operational studies include the evaluation and addressing the issues related to voltage variations, thermal harmonics, network overload, load unbalanced, faults, and network energy losses.

6.1. Power quality and voltage control

In LV distribution networks, a pure sinusoidal voltage waveform at the rated frequency (e.g., 50 Hz in the UK) is expected to be delivered to the end customers [134]. The power quality is referring to the measurements and analysis to maintain the sinusoidal voltage waveform at rated frequency [135]. Hence, the concept of power quality has been defined by International electricity commission (IEC) as "characteristics of the electricity at a given point on an electrical system, evaluated against a set of reference technical parameters". These technical parameters are the voltage and/or currents [136]. Power quality issues includes of a number of individual power system disturbance such as voltage variation (i.e., transients, long and short duration), voltage unbalance, frequency variation and waveform distortions [137]. Various indicator used to describe the power quality issues among them, voltage dip, overvoltage, under-voltage, voltage unbalance (asymmetry), voltage swell (temporary overvoltage), voltage or current harmonic distortion, and frequency deviation. With the integration of the Smart grid technologies, the power quality issues have become an increasing concern to utilities and customers [136]. For example, presence of power electronic devices increase the distortion level in LV networks which might lead to voltage or current harmonics [134]. In addition, the high penetration of DGs might possess different power quality issues. Refs [136],[137], provide a detailed investigation of the impact of DGs on power quality in LV networks. Also, ref [134] provides a detailed study of power quality in distribution networks which covers the voltage dip and harmonic distortion issues. Ref [135] provides an overview of most common power quality issues based on the energy storage system as mitigation technology.

As discussed above a big effort have been paid to mitigate the issues associated with the voltage in LV networks. Corresponding to the reason and the effects, many studies have been implemented in the area of voltage control. Among them, some of the most recent studies on the topic of voltage control and power quality in the three-phase LV network have been studied with references [51, 119–121]. In [51] a new approach for unbalanced voltage control has been proposed. The method is based on OLTC and the demand response with considering the customer preferences. A three phase voltage management method proposed in [138]. The method focused on the design a model which include OLTC and power electronic devices to control unbalance voltage among the three phases. A harmonic based analysis is proposed in [139]. The analysis is applied to the LV network aimed at assessing the power quality. In [140] a multi-function DGs unit was designed to improve the power quality in the LV network. The designed unit applied at three phases four wire LV networks to mitigate the current unbalance and harmonics.

6.2. Power flow analysis of LV networks

6.2.1. Introduction: Power flow calculation is an essential tool for various types of power system analysis studies. Based

on the network topology and the operation conditions, the power flow calculation can be implemented to evaluate all important networks elements, such as voltage angle, voltage magnitude, line power transmission, and line power losses [141]. Therefore, the power flow analyses widely used in many studies that executed to evaluated and addressed various issues such as fault analysis, feeder reconfiguration, network load balancing, network losses reduction, DGs allocation and so on. Initially, researchers have paid big attention to develop powerful power flow approaches which capable to analyses operation of the transmission networks. Indeed, the standard Newton Raphson (NR) and Gauss side (GS) power flow techniques, are widely used to evaluate the operation of power system networks. These approaches successfully converge the solutions by assuming the studied system is three phases balanced. The transmission and sub-transmission networks are structured symmetrically (tightly meshed networks) with a low R/X ratio and even allocation of load across the three phases. Thus, it is usually considered as a balanced three-phase network. Therefore, Applying the standard version of these techniques on such types of networks (HV and MV) is efficient [122], [142], [143]. Due to the characteristic difference between the transmission and distribution networks, applying the standard techniques directly on the distribution networks is failed to converge the solution without assuming that the network is three phases balanced. Although various studies applied the conventional PF techniques to analyze the LV distribution networks by assuming that the LV network is a three-phase balanced network, this assumption is unrealistic [142]. In practical the LV distribution system is unbalanced because of (1) unbalanced division of loads across the three-phase (2) unbalanced characteristic of the LV lines e.g., high R/X ratio (3) the network structure is asymmetrical e.g., single phase and two-phase lateral and (4) untransposed lines (5) uneven allocation of DGs on different phases. Therefore, using conventional PF methods fail to converge for unbalanced LV networks resulted in unrealistic indications into an actual problem [143], [144], [145], [146].

While the energy system shifting towards a more sustainable system, a significant share LCTs adopted in the LV network. Hence, LV networks become an essential part of the modern energy system. Consequently, to study the impacts of the DGs and to ensure a secure operation LV network, different research works were developed a variety of power flow methods based on the standard techniques to be able to deal with the uniqueness of the LV networks. Also, many of the recently published research works have proposed different power flow techniques. These proposed techniques cover a wide range of the LV networks operational challenges posed by the adoption of LCTs such as increasing the level of load demand variation. Meanwhile, an efficient power flow algorithm must be able to find the solution of the power flow problem for systems with a large number of nodes, asymmetrical line impedances highly violated load demands and unbalanced voltage and current. Generally, the proposed methods can be can be classified into two main categories, deterministic and probabilistic. In the following subsection, a

brief definition and review of the main power flow algorithm for LV network are provided.

6.2.2 Deterministic power flow techniques: The deterministic power flow techniques do not consider the uncertainties (stochastic nature) associated with renewable DGs and load demands [143]. In these techniques, the non-linear power flow equations are solved for a deterministic value of renewable DGs outputs and load demand [146]. Though a large number of these techniques have been proposed to date, the majority of them can come under three main groups. Forward/Backward Sweep (FBS) based methods, Newton Raphson (NR) based Methods, Gauss Z-Bus based methods and Correction Current Injection (CCI) based methods.

1. Forward, Backward Sweep (FBS) based methods: This technique is widely used in the distribution system analysis, because of its robustness and simplicity of implementation specially in case of the multi-phase circuit. The initial version of the FBS algorithm developed for the radial system in [147]. Afterward, the method has been applied in a wide range of research paper to solve weakly meshed, strong meshed and multi-phase unbalanced networks. In [148] the authors applied the FBS method to solve three phase power flow problem for a loop network. The proposed method considers the loops as two branches with considering the unbalanced conditions for three-phase networks. The result showed the effectiveness of the proposed method for radial and weakly meshed three-phase unbalanced networks. Also, a three phase PF technique to analyses unbalanced distribution network was proposed by [144]. The technique integrates the conventional forward-backward sweep (FBS) technique with employing the load impedance matrix to calculate the bus voltage in one step instead of two steps. The proposed method evaluated different three-phase balanced and unbalanced radial and weakly meshed networks and the results proved the effectiveness of the proposed method over the standard FBS technique. In references [149], [150] developed a three phase power flow method for unbalanced LV networks aimed at minimizing the network losses. The system element modelled in three phase frameworks based on the FBS technique. Breadth-first search method used along with BFS to minimize the read element in each iteration resulted in minimizing the computational time. The result showed that the three-phase proposed method is more accurate than the symmetrical model, which make it more applicable in real time analysis. In [151] the authors employed the BFS method in optimal power flow optimization formulation aimed at developing a centralized operation scheme to handle the LV network unbalance posed by high penetration of single phase DGs. The result showed that such a schema is allowed to improve system operation while ensuring its security. However, in practice, the network comprises of a large number of nodes, which limited the adoption communication infrastructure that required to apply the centralized operation schema. In addition, the FBS method used in parallel with mixed integer linear programming (MILP) approaching [152] to study the effect of LV network feeder reconfiguration on reducing the energy losses and improve the load balancing.

2. Newton Raphson (NR) based Methods: The standard Newton Raphson (NR) is failing to converge the power flow solution of the unbalanced LV network. However, various approaches developed the standard NR method study the operation of LV networks. For example, NR based three phase PF method developed in [141] using graph theory, injected current and matrix decomposition techniques. In [153] NR based power flow method has been developed to study the effect of active and reactive power injection on the network voltage. The proposed method validated in real German 234-bus test system and it has been applied in the LV system. Moreover, a three phase power flow method based on the NR and the voltage rectangle coordinates method has been proposed in [154]. The effectiveness of the proposed method tested by implementing a case study and the result compared with OpenDSS power flow software results. In [155] The author developed five new versions of NR power flow technique to solve three phase power flow problem for unbalanced LV network. The formulation for three phase power flow is described for both current and power. To validate the proposed methods, the development versions have been compared with the BFS method. Also, [156] developed a novel power flow technique for radial and weakly meshed distribution network. The proposed method based on the NR algorithm. The developed method has been tested using 33 and 69 IEEE benchmark, considering different load conditions and R/X ratio.

3. Gauss Z-Bus based methods: Gauss Z-Bus is one of the commonly used methods for solving power flow problem. It uses the Ybus matrix to model the network structure and employing current injection technique to calculate the power flow solution. One of the first methods that applied Gauss Zbus algorithm to calculate the power flow solution for unbalanced three phase low voltage networks have been presented in [157]. Also, a modified Gauss- Zbus method for three phase power flow was proposed by [158]. The modified method considers the three-phase distribution network as three single-phase distribution networks, thus the power flow can be solved phase by phase. [159] proposed a three-phase power unbalanced flow technique based on Gauss Zbus algorithm and loop frame of references. Ref [160] developed a three phase power flow program based on the implicit Gauss Zbus method. The proposed method was developed to study the impact of multi DGs on 3 phase 400 V microgrid. In addition, a Gauss Zbus approach has been employed to develop a multi-phase power flow simulation which could open as presented in reference [161]. Moreover, a similar approach has been used along with FBS to develop GridLa-D software by the US department of energy as presented in reference [162]. Recently, [163] employed the concept Gauss Zbus technique to developed modified technique which is able to solve the power flow problem for three-phase active distribution network (ADS).

4. Current Injection based methods: this method is attracting some attention in the state of art. The formulation based nodal current injection written in phase farm reference. The method was initially developed by [164]. Afterward, it was developed to cope with three-phase unbalanced LV network in [165][166][167]. [168] implemented a comparison study between the current injection method and FBS for three phase

power flow calculation. Moreover, [169] proposed an improved version of the current injection method which is able to solve the power flow problem for three phases active LV network. In addition, a multi-phase power flow methodology called **correction Current Injection based** was evolved from the complex admittance matrix methodology which reported in [170]. The complex admittance matrix allows representation of any number of phase and earth conductors in the system. It obtains by definition of self and mutual coupling between the phases [170]. Indeed, the current injection method was initially presented in [171]. Afterward, it has enhanced in [172].

6.2.3. Probabilistic (uncertainty-based) Power flow techniques: The uncertainty could be defined as the probability of difference between the anticipated and actual values. On LV networks, many variables have a stochastic nature, such as the load demand and the renewable DGs output. Therefore, therefore deterministic values for the voltages and currents can often give an incomplete view of the LV-network. Hence, when analyzing the LV network operation, it is essential to model the system stochastic variables using appropriate and practicable methods. These methods can be either a numerical or analytical. In this context, many research papers have been developed a probabilistic power flow technique. The most common way of applying a probabilistic power flow is using Monte Carlo simulation which used in references, [173–177]. In [142] multi objective probabilistic power flow method considering three-phase unbalance LV network was developed. The method adopted ANM schema and employed a Monte Carlo simulation and fuzzy satisfying method for system uncertainty modelling. [173] developed a populistic power flow method which is able to analyses daily network operation under uncertain and stress conditions. The proposed technique based on the generalized Polynomial Chaos algorithm, Monti Carlo simulation and Probabilistic density factor PDF. [174] developed a Monte Carlo based power flow methodology to assess the impact of Electric Vehicle EV on LV networks. The method employed Gaussian distribution function to model the EV plug-in times and Weibull distribution function to model the daily travel times. [175] developed a three-phase probabilistic power flow to evaluate the effectiveness of PV inverter in mitigation voltage unbalance. In addition, fuzzy set theory has been used to analyses the LV networks with uncertainties in load and renewable DGs and storage systems in [178][179][180]. In [66] Gaussian mixture distribution used to model the load demand uncertainty. Point Estimate Method applied in [181] to develop a probabilistic power flow for unbalancing distribution networks. Moreover, the probability density evolution method (PDEM) applied in [182] to develop a probabilistic power flow algorithm. Constant impedance-current-power (ZIP) model used in [183],[184] to model the load demand and renewable DGs. [183] proposed linear methods for steady-state analysis of LV networks. The ZIP model employed to represent the uncontrolled loads, both P-Q and P-V control for DGs. Bi-directional power flow was proposed [185] considering the uncertainties associated with wind.

6.2.4. Other power flow techniques: In addition to the aforementioned methods different published paper has employed different algorithms to solve the power flow for LV

networks. In [143] the authors have proposed, PF method for siting DGs into a multi-phase LV distribution network using particle swarm optimization (PSO) technique. The effectiveness of the proposed technique evaluated by a case study using multi-phase 123 IEEE test bed. The results proved the accuracy of the proposed method in the allocation of DGs. In [145] the authors proposed analytical optimal PF algorithm to assess the loadability of the LV network to host high level of PV with considering the three-phase unbalanced conditions of the networks to ensure the system voltage stability. A three-phase LV network operation, Dynamic reconfiguration operation technique proposed in [146]. The method employed the Active network management (ANM) scheme and OPF aimed at improving the system reliability and minimizing the line power losses.

6.3. LV Network reconfiguration

The network reconfiguration is changing the structure of the network feeders by changing the state of tie switches (Open/close). The feeder reconfiguration used to enhance the system reliability and the quality of supply under study state operation condition as well as under fault conditions [186]. In LV network operation studies, the network reconfiguration caught high attention in recent published literature. The different researcher has studied the LV the network reconfiguration as a method to mitigate some technical challenges such as losses, load unbalance, overloaded, voltage variation and faults [187]. Loss reduction and load balancing using as an objective function in references [44–48], [146], [188–190].

7. Conclusion and Recommendation

Around the world, the energy industry is moving towards a more sustainable system with high penetration of renewable DGs and low carbon technologies at the end user side. While the significant portion of this technology is installed on the LV distribution network, new planning and operation frameworks were developed by different researchers and research organizations around the globe. In this context, this paper provides a comprehensive review of various LV distribution networks planning and operation frameworks. Starting with highlighting the key challenges facing the LV networks, which are posed by the high penetration of DGs. Then highlights the key characteristic and topologies of LV networks. Thereafter, different planning and operation aspect have been investigated.

7.1. Remarks for future research

(1) The LV networks are typically operated in a radial topology. However, based on the operation conditions and the served load, the LV networks can be operated in different topology such as mesh, paralleled interconnected and so on. For instance, normally in the urban networks the adjacent feeders are interconnected through a link boxes and so form a mesh configuration. Hence, for network planning and operation it is recommended to consider the mesh topology and the actual network topology by developing a network model which consider and measuring the current flow through the link boxes rather than assumed to be zero aimed at improving the accuracy of the network impedances model. (2) With the deployment of ICS such as Advance Metering Infrastructure (AMI), the SG will enable two way flows of power and data. In this context

there are opportunities to apply Big Data Analytics and IoT in the future power system. Deployment of such information technologies (IT) represents a very promising research direction which have not yet studied in the literature. Among these, studying the benefits of applying big data analytics to enhance demand response, detect the faults, planning and operation of the LV networks and reduce the impact of uncertainties.

(3) The majority of the reviewed papers addressing the planning of HV/MV network with high penetration of DGs. However, a few papers have developed network dynamic models to implement a long term planning of DGs in LV network. Hence, an accurate dynamic network model needs to be implemented for long term planning of LV network, which is able to address the presence of high level of uncertainties posed by various sources such as LCTs and loads. (4) An accurate and fast probabilistic Power flow method for three phase unbalance networks needs to be developed.

7.2. Remarks for practices

(1) With the introduction of high penetration of LCTs, the practices and regulations used in network planning need reformation. Where the impact of the LCTs highly risky if not handle in the planning and operation regulation. For instance, the traditional practices and regulations are based on conventional will not necessarily have the correct safety margins for the different characteristics of embedded generation or new types of loads. As a result, the networks will be operated in conditions that are closer to the rated limits, which might follow by different technical issues such as voltage unbalanced. The new practices must consider making 'before' and 'after' assessments of the LCTs impacts. (2) It is recommended for the DNOs reform the network to more intelligent network, by adding the smart grid technologies such as smart meters and replacing all the manual switches by automatic switches, installing distributed transformer adapted with OLTC in order to prepare the networks to move towards fully automated networking smart cities.

Acknowledgments This work was funded by Mu'tah University. Indeed, the authors would like to thank Mu'tah University for their sponsorship and support for this research.

References

- 1 Singh, B., Sharma, J.: 'A review on distributed generation planning' *Renew. Sustain. Energy Rev.*, 2017, **76**, (March), pp. 529–544.
- 2 Fathima, A.H., Palanisamy, K.: 'Optimization in microgrids with hybrid energy systems - A review' *Renew. Sustain. Energy Rev.*, 2015, **45**, pp. 431–446.
- 3 Abdmouleh, Z., Gastli, A., Ben-Brahim, L., Haouari, M., Al-Emadi, N.A.: 'Review of optimization techniques applied for the integration of distributed generation from renewable energy sources' *Renew. Energy*, 2017, **113**, pp. 266–280.
- 4 Ehsan, A., Yang, Q.: 'Optimal integration and planning of renewable distributed generation in the power distribution networks: A review of analytical techniques' *Appl. Energy*, 2018, **210**, (July 2017), pp. 44–59.
- 5 Energy Information Administration: 'International Energy Outlook 2016-World energy demand and economic outlook' (2016)
- 6 Murata, R.: 'Study on Life Cycle Carbon Minus House Part2: Design of demonstration house' 2017, (March).
- 7 Theo, W.L., Lim, J.S., Ho, W.S., Hashim, H., Lee, C.T.: 'Review of distributed generation (DG) system planning and optimisation techniques: Comparison of numerical and mathematical modelling methods' *Renew. Sustain. Energy Rev.*, 2017, **67**, pp. 531–573.
- 8 Morgan, J., Dagnet, Y., Tirpak, D.: 'Elements and ideas for the 2015 Paris agreement' *World Resour. Inst.*, 2014, **Working Pa.**, (December 2014), pp. 1–8.
- 9 Anaya, K.L., Pollitt, M.G.: 'Integrating distributed generation: Regulation and trends in three leading countries' *Energy Policy*, 2015, **85**, pp. 475–486.
- 10 Shahinzadeh, H., Moazzami, M., Fathi, S.H., Gharehpetian, G.B.: 'Optimal sizing and energy management of a grid-connected microgrid using HOMER software' *2016 Smart Grids Conf. SGC 2016*, 2017, pp. 13–18.
- 11 HM Parliament: 'The Carbon Plan: Delivering our low carbon future' *Energy*, 2011, (December), p. 218.
- 12 Nijhuis, M., Gibescu, M., Cobben, J.F.G.: 'Assessment of the impacts of the renewable energy and ICT driven energy transition on distribution networks' *Renew. Sustain. Energy Rev.*, 2015, **52**, pp. 1003–1014.
- 13 Edwards, M. V., Campbell, R.G., Chapman, T., *et al.*: 'Spray-dried porcine plasma and yeast derived protein meal influence the adaptation to weaning of primiparous and multiparous sow progeny in different ways' *Anim. Prod. Sci.*, 2013, **53**, (1), pp. 75–86.
- 14 Viral, R., Khatod, D.K.: 'Optimal planning of distributed generation systems in distribution system: A review' *Renew. Sustain. Energy Rev.*, 2012, **16**, (7), pp. 5146–5165.
- 15 Alnaser, S.: 'PhD Thesis: Control of Distributed Generation and Storage: Operation and Planning Perspectives Sahban Alnaser' 2015.
- 16 Simmonds, G.: 'Regulation of the UK Electricity Industry' *Regul. Ind. Br. CRI*, 2002, pp. 1–143.
- 17 Lakervi, E., Holmes, E.J.: 'Electricity Distribution Network Design' (Institution of Engineering and Technology, 2007, second)
- 18 'Engineering Technical Report 140 July 2017 Statutory Voltage Limits at customers' terminals in the UK and options for future application of wider limits at low voltage' 2017, (July).
- 19 Schneider Electric: 'Electrical installation guide' 2009, pp. 1–467.
- 20 Li, Y., Crossley, P.A.: 'Impact of electric vehicles on LV feeder voltages' *IEEE Power Energy Soc. Gen. Meet.*, 2014, **2014-Octob.**, (October).
- 21 Li, Y., Crossley, P.A.: 'Voltage balancing in low-voltage radial feeders using Scott transformers' *IET Gener. Transm. Distrib.*, 2014, **8**, (8), pp. 1489–1498.
- 22 Taylor, A.V.: 'Electricity Distribution Network Design' *IEE Rev.*, 1990, **36**, (4), p. 154.
- 23 E.ON Central Networks: 'Network Design Manual' 2006, (December), p. 194.
- 24 Li, Y.: 'Voltage balancing on three-phase low voltage feeder' 2015.
- 25 Csanyi, E.: 'North American versus European distribution systems', <https://electrical-engineering-portal.com/north-american-versus-european-distribution-systems>
- 26 Navarro-Espinosa, A., Ochoa, L.F., Randles, D.: 'Assessing the benefits of meshed operation of LV feeders with low carbon technologies' *2014 IEEE PES Innov. Smart Grid Technol. Conf. ISGT 2014*, 2014, (February 2014).
- 27 Aydin, M.S., Navarro-Espinosa, A., Ochoa, L.F.: 'Investigating the benefits of meshing real UK LV network' *Cired*, 2015, **2**, (June), pp. 15–18.
- 28 H.Lee Willis: 'Power Distribution Planning Reference Book' (2004)
- 29 Navarro-Espinosa, A., Ochoa, L.F.: 'Probabilistic Impact Assessment of Low Carbon Technologies in LV Distribution Systems' *IEEE Trans. Power Syst.*, 2016, **31**, (3), pp. 2192–2203.
- 30 Chen, T.H., Huang, W.T., Gu, J.C., Pu, G.C., Hsu, Y.F., Guo, T.Y.: 'Feasibility study of upgrading primary feeders from radial and

- open-loop to normally closed-loop arrangement' *IEEE Trans. Power Syst.*, 2004, **19**, (3), pp. 1308–1316.
- 31 '4 Main Types Of Distribution Feeder Systems To Recognize | EEP', <https://electrical-engineering-portal.com/4-main-types-distribution-feeder-systems#radial-distribution-system>, accessed January 2019
 - 32 Nijhuis, M.: 'Long-term planning of low voltage networks' (2017)
 - 33 C.F. Wagner; R.D. Evans: 'Symmetrical Components as Applied to the Analysis of Unbalanced Electrical Circuits' (McGraw-Hill Book Company, 1961)
 - 34 Beharrysingh, S.: 'Phase unbalance on networks and its mitigation Phase unbalance on low-voltage electricity networks and its mitigation using static balancers by' 2014, p. 299.
 - 35 Jr., William Stevenson (Author), J.G. (Author): 'POWER SYSTEMS ANALYSIS (SI)' (2016)
 - 36 Chua, K.H., Wong, J., Lim, Y.S., Taylor, P., Morris, E., Morris, S.: 'Mitigation of voltage unbalance in low voltage distribution network with high level of photovoltaic system' *Energy Procedia*, 2011, **12**, (603), pp. 495–501.
 - 37 Zheng, W., Wu, W., Zhang, B., Sheng, W.: 'Optimal residential demand response considering the operational constraints of unbalanced distribution networks' *IEEE Power Energy Soc. Gen. Meet.*, 2018, **2018-Janua**, (i), pp. 1–5.
 - 38 Ul-Haq, A., Cecati, C., Strunz, K., Abbasi, E.: 'Impact of Electric Vehicle Charging on Voltage Unbalance in an Urban Distribution Network' *Intell. Ind. Syst.*, 2015, **1**, (1), pp. 51–60.
 - 39 Moghbel, M., Masoum, M. a S., Shahnia, F., Moses, P.: 'Distribution transformer loading in unbalanced three-phase residential networks with random charging of plug-in electric vehicles' 2012, (Table I), pp. 1–6.
 - 40 Mansor, N.N., Levi, V.: 'Integrated Planning of Distribution Networks Considering Utility Planning Concepts' *IEEE Trans. Power Syst.*, 2017, **32**, (6), pp. 4656–4672.
 - 41 Weatherhead, S.: 's k r o w e b o n Future l r a b i w o x Fle for a' no date, (September 2015).
 - 42 Desmet, J., Putman, D., D'hulster, F., Belmans, R.: 'Thermal analysis of the influence of nonlinear, unbalanced and asymmetric loads on current conducting capacity of LV-cables' 2003, **4**, p. 8 pp. Vol.4-
 - 43 Taghikhani, M.A., Rafiei, M.: 'Thermal coefficient measurements of typical distribution transformers operating under imbalance conditions' *16th Electr. Power Distrib. Conf. EPDC 2011*, 2011, pp. 1–6.
 - 44 Siti, M.W., Nicolae, D.V., Jimoh, A.A., Ukil, A.: 'Reconfiguration and load balancing in the LV and MV distribution networks for optimal performance' *IEEE Trans. Power Deliv.*, 2007, **22**, (4), pp. 2534–2540.
 - 45 Nicolae, D. V., Siti, M.W., Jimoh, A.A.: 'LV self balancing distribution network reconfiguration for minimum losses' *2009 IEEE Bucharest PowerTech Innov. Ideas Toward. Electr. Grid Futur.*, 2009, pp. 1–6.
 - 46 Ganesh, S., Kanimozhi, R.: 'Meta-heuristic technique for network reconfiguration in distribution system with photovoltaic and D-STATCOM' *IET Gener. Transm. Distrib.*, 2018, **12**, (20), pp. 4524–4535.
 - 47 Gao, L., Rouskas, G.N.: 'Virtual Network Reconfiguration with Load Balancing and Migration Cost Considerations' *Proc. - IEEE INFOCOM*, 2018, **2018-April**, pp. 2303–2311.
 - 48 Guo, Z., Li, X., Geng, J., Wu, B.: 'Distribution Network Reconfiguration based on Opposition Learning Genetic Algorithm' *Int. Conf. Innov. Smart Grid Technol. ISGT Asia 2018*, 2018, **3**, pp. 345–349.
 - 49 Rq, R., Lv w u l e x w l r q, O., Vegunta, S.C., Twomey, P., Randles, D.: 'IMPACT OF PV AND LOAD PENETRATION ON LV NETWORK VOLTAGES AND UNBALANCE AND POTENTIAL SOLUTIONS RESULTS , DISCUSSION , AND FINDINGS Fixed Time Load and PV Generation Time Dependent Load and PV Generation' no date, **5**, pp. 3–6.
 - 50 Shahnia, F., Ghosh, A., Ledwich, G., Zare, F.: 'Voltage Unbalance reduction in low voltage distribution networks with rooftop PVs' *Univ. Power Eng. Conf. (AUPEC), 2010 20th Australas.*, 2010, (1), pp. 1–5.
 - 51 Rahman, M.M., Arefi, A., Shafiqullah, G.M., Hettiwatte, S.: 'A new approach to voltage management in unbalanced low voltage networks using demand response and OLTC considering consumer preference' *Int. J. Electr. Power Energy Syst.*, 2018, **99**, (December 2017), pp. 11–27.
 - 52 Pezeshki, H., Arefi, A., Ledwich, G., Wolfs, P.: 'Probabilistic Voltage Management Using OLTC and dSTATCOM in Distribution Networks' *IEEE Trans. Power Deliv.*, 2018, **33**, (2), pp. 570–580.
 - 53 Bettanin, A., Coppo, M., Savio, A., Turri, R.: 'Voltage management strategies for low voltage networks supplied through phase-decoupled on-load-tap-changer transformers' *2017 AEIT Int. Annu. Conf. Infrastructures Energy ICT Oppor. Foster. Innov. AEIT 2017*, 2017, **2017-Janua**, pp. 1–6.
 - 54 Shen, J., Schroder, S., Duro, B., Roesner, R.: 'A neutral-point balancing controller for a three-level inverter with full power-factor range and low distortion' *IEEE Trans. Ind. Appl.*, 2013, **49**, (1), pp. 138–148.
 - 55 Giri, S.K., Mukherjee, S., Chakrabarti, S., Banerjee, S., Chakraborty, C.: 'A double signal PWM scheme for neutral point voltage balancing in three level NPC converters' *IECON 2015 - 41st Annu. Conf. IEEE Ind. Electron. Soc.*, 2015, pp. 1782–1787.
 - 56 Luo, R., He, Y., Liu, J.: 'Research on the unbalanced compensation of delta-connected cascaded H-bridge multilevel SVG' *IEEE Trans. Ind. Electron.*, 2018, **65**, (11), pp. 8667–8676.
 - 57 Guillardia, H., Liberado, E.V., Pomilio, J.A., Marafão, F.P.: 'General-compensation-purpose Static var Compensator prototype' *HardwareX*, 2019, **5**, p. e00049.
 - 58 Chang, W.-N., Chang, C.-M., Yen, S.-K.: 'Improvements in Bidirectional Power-Flow Balancing and Electric Power Quality of a Microgrid with Unbalanced Distributed Generators and Loads by Using Shunt Compensators' *Energies*, 2018, **11**, (12), p. 3305.
 - 59 Shahnia, F., Ghosh, A., Ledwich, G., Zare, F.: 'An approach for current balancing in distribution networks with rooftop PVs' *IEEE Power Energy Soc. Gen. Meet.*, 2012, pp. 1–6.
 - 60 Ahmadi, D., Tavakoli Bina, M., Golkar, M.: 'A comprehensive comparison between three practical topologies of the load-balancing transformers' *PEDSTC 2010 - 1st Power Electron. Drive Syst. Technol. Conf.*, 2010, **1**, pp. 357–360.
 - 61 Ahmadi, D., Bina, M.T., Golkar, M.: 'A critical cross-examination on load-balancing transformers for distribution systems' *IEEE Trans. Power Deliv.*, 2010, **25**, (3), pp. 1645–1656.
 - 62 Ahmadi, D., Bina, M.T., Golkar, M.A.: 'Effects of distorted source on operating a load-balancing transformer in a distribution network' *Proc. - 2010 18th Iran. Conf. Electr. Eng. ICEE 2010*, 2010, pp. 796–800.
 - 63 Li, R., Wang, W., Chen, Z., Jiang, J., Zhang, W.: 'A review of optimal planning active distribution system: Models, methods, and future researches' *Energies*, 2017, **10**, (11), pp. 1–27.
 - 64 Georgilakis, P.S., Hatziargyriou, N.D.: 'A review of power distribution planning in the modern power systems era: Models, methods and future research' *Electr. Power Syst. Res.*, 2015, **121**, pp. 89–100.
 - 65 Nazari, A.A., Keypour, R.: 'A two-stage stochastic model for energy storage planning in a microgrid incorporating bilateral contracts and demand response program' *J. Energy Storage*, 2019, **21**, (December 2018), pp. 281–294.
 - 66 Nijhuis, M., Gibescu, M., Cobben, S.: 'Gaussian Mixture Based

- Probabilistic Load Flow for LV-Network Planning' *IEEE Trans. Power Syst.*, 2017, **32**, (4), pp. 2878–2886.
- 67 Taghizadegan Kalantari, N., Safari, A., Shahsavari, H., Farrokhifar, M., Bakhshi Yamchi, H.: 'A cost-efficient application of different battery energy storage technologies in microgrids considering load uncertainty' *J. Energy Storage*, 2019, **22**, (December 2018), pp. 17–26.
 - 68 Carpinelli, G., Mottola, F., Proto, D., Russo, A., Varilone, P.: 'A Hybrid Method for Optimal Siting and Sizing of Battery Energy Storage Systems in Unbalanced Low Voltage Microgrids' *Appl. Sci.*, 2018, **8**, (3), p. 455.
 - 69 de Christo, T.M., Perron, S., Fardin, J.F., Simonetti, D.S.L., de Alvarez, C.E.: 'Demand-side energy management by cooperative combination of plans: A multi-objective method applicable to isolated communities' *Appl. Energy*, 2019, **240**, (February), pp. 453–472.
 - 70 Jannesar, M.R., Sedighi, A., Savaghebi, M., Guerrero, J.M.: 'Optimal placement, sizing, and daily charge/discharge of battery energy storage in low voltage distribution network with high photovoltaic penetration' *Appl. Energy*, 2018, **226**, (June), pp. 957–966.
 - 71 Rupolo, D., Pereira, B.R., Contreras, J., Mantovani, J.R.S.: 'Medium- and low-voltage planning of radial electric power distribution systems considering reliability' *IET Gener. Transm. Distrib.*, 2017, **11**, (9), pp. 2212–2221.
 - 72 Chen, Z., Chen, M., Li, Q., Lin, H., Gao, M.: 'MAS-based distributed control method for multi-microgrids with high-penetration renewable energy' *Energy*, 2018, **171**, pp. 284–295.
 - 73 Shafie-khah, M., Heidari, A., Nazar, M.S., Catalão, J.P.S., Varasteh, F.: 'Distributed energy resource and network expansion planning of a CCHP based active microgrid considering demand response programs' *Energy*, 2019, **172**, pp. 79–105.
 - 74 Naderi, E., Seifi, H., Sepasian, M.S.: 'A dynamic approach for distribution system planning considering distributed generation' *IEEE Trans. Power Deliv.*, 2012, **27**, (3), pp. 1313–1322.
 - 75 Falaghi, H., Singh, C., Haghifam, M.R., Ramezani, M.: 'DG integrated multistage distribution system expansion planning' *Int. J. Electr. Power Energy Syst.*, 2011, **33**, (8), pp. 1489–1497.
 - 76 Ganguly, S., Sahoo, N.C., Das, D.: 'Mono- and multi-objective planning of electrical distribution networks using particle swarm optimization' *Appl. Soft Comput. J.*, 2011, **11**, (2), pp. 2391–2405.
 - 77 Kulms, T., Meinerzhagen, A.K., Koopmann, S., Schnettler, A.: 'A simulation framework for assessing the market and grid driven value of flexibility options in distribution grids' *J. Energy Storage*, 2018, **17**, pp. 203–212.
 - 78 Gitizadeh, M., Vahed, A.A., Aghaei, J.: 'Multistage distribution system expansion planning considering distributed generation using hybrid evolutionary algorithms' *Appl. Energy*, 2013, **101**, pp. 655–666.
 - 79 Oates¹, M., Melia¹, A., Ferrando¹, V.: 'VIRTUAL POWER PLANT PROTOTYPE AND IURBAN CASE STUDIES' *Int. J. Entrep. Sustain. ISSUES*, 2017, **4**, (3).
 - 80 Sugihara, H., Yokoyama, K., Saeki, O., Tsuji, K., Funaki, T.: 'Economic and efficient voltage management using customer-owned energy storage systems in a distribution network with high penetration of photovoltaic systems' *IEEE Trans. Power Syst.*, 2013, **28**, (1), pp. 102–111.
 - 81 Zou, K., Agalgaonkar, A.P., Muttaqi, K.M., Perera, S.: 'Distribution system planning with incorporating DG reactive capability and system uncertainties' *IEEE Trans. Sustain. Energy*, 2012, **3**, (1), pp. 112–123.
 - 82 Bin Humayd, A.S., Bhattacharya, K.: 'Distribution system planning to accommodate distributed energy resources and PEVs' *Electr. Power Syst. Res.*, 2017, **145**, pp. 1–11.
 - 83 Yao, W., Zhao, J., Wen, F., *et al.*: 'A multi-objective collaborative planning strategy for integrated power distribution and electric vehicle charging systems' *IEEE Trans. Power Syst.*, 2014, **29**, (4), pp. 1811–1821.
 - 84 Guerra Sánchez, L.G.: 'Analysis of power distribution systems using a multicore environment' *TDX (Tesis Dr. en Xarxa)*, 2016, (March).
 - 85 Saboori, H., Hemmati, R., Abbasi, V.: 'Multistage distribution network expansion planning considering the emerging energy storage systems' *Energy Convers. Manag.*, 2015, **105**, pp. 938–945.
 - 86 Haque, A.N.M.M., Nguyen, P.H., Bliet, F.W., Sloatweg, J.G.: 'Demand response for real-time congestion management incorporating dynamic thermal overloading cost' *Sustain. Energy, Grids Networks*, 2017, **10**, pp. 65–74.
 - 87 Arasteh, H., Sepasian, M.S., Vahidinasab, V., Siano, P.: 'SoS-based multiobjective distribution system expansion planning' *Electr. Power Syst. Res.*, 2016, **141**, pp. 392–406.
 - 88 Ganguly, S., Samajpati, D.: 'Distributed generation allocation with on-load tap changer on radial distribution networks using adaptive genetic algorithm' *Appl. Soft Comput. J.*, 2017, **59**, pp. 45–67.
 - 89 Kumar, D., Samantaray, S.R., Joos, G.: 'A reliability assessment based graph theoretical approach for feeder routing in power distribution networks including distributed generations' *Int. J. Electr. Power Energy Syst.*, 2014, **57**, pp. 11–30.
 - 90 Rosseti, G.J.S., De Oliveira, E.J., De Oliveira, L.W., Silva, I.C., Peres, W.: 'Optimal allocation of distributed generation with reconfiguration in electric distribution systems' *Electr. Power Syst. Res.*, 2013, **103**, pp. 178–183.
 - 91 Samper, M.E., Vargas, A.: 'Investment decisions in distribution networks under uncertainty with distributed generation - Part i: Model formulation' *IEEE Trans. Power Syst.*, 2013, **28**, (3), pp. 2331–2340.
 - 92 Abate, F., Carratù, M., Liguori, C., Paciello, V.: 'A low cost smart power meter for IoT' *Meas. J. Int. Meas. Confed.*, 2019, **136**, pp. 59–66.
 - 93 Ziari, I., Ledwich, G., Ghosh, A., Platt, G.: 'Optimal distribution network reinforcement considering load growth, line loss, and reliability' *IEEE Trans. Power Syst.*, 2013, **28**, (2), pp. 587–597.
 - 94 Viana, M.S., Manassero, G., Udaeta, M.E.M.: 'Analysis of demand response and photovoltaic distributed generation as resources for power utility planning' *Appl. Energy*, 2018, **217**, (February), pp. 456–466.
 - 95 Pilehvar, M.S., Shadmand, M.B., Mirafzal, B.: 'Analysis of Smart Loads in Nanogrids' *IEEE Access*, 2019, **7**, pp. 548–562.
 - 96 Hejazi, H.A., Araghi, A.R., Vahidi, B., Hosseini, S.H., Abedi, M., Mohsenian-Rad, H.: 'Independent distributed generation planning to profit both utility and DG investors' *IEEE Trans. Power Syst.*, 2013, **28**, (2), pp. 1170–1178.
 - 97 Sun, M., Wang, Y., Strbac, G., Kang, C.: 'Probabilistic Peak Load Estimation in Smart Cities Using Smart Meter Data' *IEEE Trans. Ind. Electron.*, 2019, **66**, (2), pp. 1608–1618.
 - 98 Driesen, J., Tao, Z., Riaz, Z., Mehmood, F., Kazmi, H.: 'Electricity load-shedding in Pakistan: Unintended consequences, opportunities and policy recommendations' *Energy Policy*, 2019, **128**, (December 2018), pp. 411–417.
 - 99 Sardi, J., Mithulananthan, N., Gallagher, M., Hung, D.Q.: 'Multiple community energy storage planning in distribution networks using a cost-benefit analysis' *Appl. Energy*, 2017, **190**, pp. 453–463.
 - 100 Tina, G.M., Garozzo, D., Siano, P.: 'Scheduling of PV inverter reactive power set-point and battery charge/discharge profile for voltage regulation in low voltage networks' *Int. J. Electr. Power Energy Syst.*, 2019, **107**, (October 2018), pp. 131–139.
 - 101 Shen, X., Shahidepour, M., Han, Y., Zhu, S., Zheng, J.:

- 'Expansion Planning of Active Distribution Networks With Centralized and Distributed Energy Storage Systems'*IEEE Trans. Sustain. Energy*, 2017, **8**, (1), pp. 126–134.
- 102 Ali, M.S., Haque, M.M., Wolfs, P.: 'A review of topological ordering based voltage rise mitigation methods for LV distribution networks with high levels of photovoltaic penetration'*Renew. Sustain. Energy Rev.*, 2019, **103**, (December 2018), pp. 463–476.
- 103 Zeng, B., Wen, J., Shi, J., Zhang, J., Zhang, Y.: 'A multi-level approach to active distribution system planning for efficient renewable energy harvesting in a deregulated environment'*Energy*, 2016, **96**, pp. 614–624.
- 104 Zhang, J., Fan, H., Tang, W., Wang, M., Cheng, H., Yao, L.: 'Planning for distributed wind generation under active management mode'*Int. J. Electr. Power Energy Syst.*, 2013, **47**, (1), pp. 140–146.
- 105 Kumar, D., Samantaray, S.R., Kamwa, I.: 'MOSOA-based multiobjective design of power distribution systems'*IEEE Syst. J.*, 2017, **11**, (2), pp. 1182–1195.
- 106 Sahoo, N.C., Ganguly, S., Das, D.: 'Fuzzy-Pareto-dominance driven possibilistic model based planning of electrical distribution systems using multi-objective particle swarm optimization'*Expert Syst. Appl.*, 2012, **39**, (1), pp. 881–893.
- 107 Sahoo, N.C., Ganguly, S., Das, D.: 'Multi-objective planning of electrical distribution systems incorporating sectionalizing switches and tie-lines using particle swarm optimization'*Swarm Evol. Comput.*, 2012, **3**, pp. 15–32.
- 108 Vieira Pombo, A., Murta-Pina, J., Fernão Pires, V.: 'Multiobjective formulation of the integration of storage systems within distribution networks for improving reliability'*Electr. Power Syst. Res.*, 2017, **148**, pp. 87–96.
- 109 Li, Y., Crossley, P. a.: 'Voltage control on unbalanced LV networks using tap changing transformers'*11th IET Int. Conf. Dev. Power Syst. Prot. (DPSP 2012)*, 2012, (November 2016), pp. 21–21.
- 110 Xiang, Y., Yang, W., Liu, J., Li, F.: 'Multi-objective distribution network expansion incorporating electric vehicle charging stations'*Energies*, 2016, **9**, (11), pp. 1–17.
- 111 Aghaei, J., Muttaqi, K.M., Azizivahed, A., Gitizadeh, M.: 'Distribution expansion planning considering reliability and security of energy using modified PSO (Particle Swarm Optimization) algorithm'*Energy*, 2014, **65**, pp. 398–411.
- 112 Chen, T.H., Lin, E.H., Yang, N.C., Hsieh, T.Y.: 'Multi-objective optimization for upgrading primary feeders with distributed generators from normally closed loop to mesh arrangement'*Int. J. Electr. Power Energy Syst.*, 2013, **45**, (1), pp. 413–419.
- 113 Esmaeeli, M., Kazemi, A., Shayanfar, H., Chicco, G., Siano, P.: 'Risk-based planning of the distribution network structure considering uncertainties in demand and cost of energy'*Energy*, 2017, **119**, pp. 578–587.
- 114 Kanwar, N., Gupta, N., Niazi, K.R., Swarnkar, A.: 'Optimal Allocation of DGs and Reconfiguration of Radial Distribution Systems Using an Intelligent Search-based TLBO'*Electr. Power Components Syst.*, 2017, **45**, (5), pp. 476–490.
- 115 Nick, M., Cherkaoui, R., Paolone, M.: 'Optimal Planning of Distributed Energy Storage Systems in Active Distribution Networks Embedding Grid Reconfiguration'*IEEE Trans. Power Syst.*, 2018, **33**, (2), pp. 1577–1590.
- 116 Long, C., Ochoa, L.F.: 'Voltage control of PV-rich LV networks: OLTC-fitted transformer and capacitor banks'*IEEE Trans. Power Syst.*, 2016, **31**, (5), pp. 4016–4025.
- 117 Zeng, B., Zhang, J., Yang, X., Wang, J., Dong, J., Zhang, Y.: 'Integrated planning for transition to low-carbon distribution system with renewable energy generation and demand response'*IEEE Trans. Power Syst.*, 2014, **29**, (3), pp. 1153–1165.
- 118 Bagheri, A., Monsef, H., Lesani, H.: 'Integrated distribution network expansion planning incorporating distributed generation considering uncertainties, reliability, and operational conditions'*Int. J. Electr. Power Energy Syst.*, 2015, **73**, pp. 56–70.
- 119 Zeng, B., Zhang, J., Zhang, Y., Yang, X., Dong, J., Liu, W.: 'Active distribution system planning for low-carbon objective using cuckoo search algorithm'*J. Electr. Eng. Technol.*, 2014, **9**, (2), pp. 433–440.
- 120 Al Kaabi, S.S., Zeineldin, H.H., Khadkikar, V.: 'Planning active distribution networks considering multi-DG configurations'*IEEE Trans. Power Syst.*, 2014, **29**, (2), pp. 785–793.
- 121 Liu, W., Xu, H., Niu, S.: 'An integrated planning method of active distribution system considering decentralized voltage control'*IEEE Power Energy Soc. Gen. Meet.*, 2016, **2016–Novem**, pp. 1–5.
- 122 Liu, W., Xu, H., Niu, S., Xie, J.: 'Optimal distributed generator allocation method considering voltage control cost'*Sustain.*, 2016, **8**, (2).
- 123 Mokryani, G., Hu, Y.F., Papadopoulos, P., Niknam, T., Aghaei, J.: 'Deterministic approach for active distribution networks planning with high penetration of wind and solar power'*Renew. Energy*, 2017, **113**, pp. 942–951.
- 124 List, C., Authors, O.F., Nijhuis, M., Babar, M., Gibescu, M., Cobben, S.: 'Work "): Demand response: Social welfare maximisation in an unbundled energy market -- Case study for the low-voltage networks of a distribution network operator in the Netherlands'2015, **53**, (1), pp. 32–38.
- 125 Mokryani, G., Hu, Y.F., Pillai, P., Rajamani, H.S.: 'Active distribution networks planning with high penetration of wind power'*Renew. Energy*, 2017, **104**, pp. 40–49.
- 126 Siano, P., Mokryani, G.: 'Evaluating the Benefits of Optimal Allocation of Wind Turbines for Distribution Network Operators'*IEEE Syst. J.*, 2015, **9**, (2), pp. 629–638.
- 127 Montoya-Bueno, S., Munoz, J.L., Contreras, J.: 'A Stochastic Investment Model for Renewable Generation in Distribution Systems'*IEEE Trans. Sustain. Energy*, 2015, **6**, (4), pp. 1466–1474.
- 128 Nijhuis, M., Gibescu, M., Cobben, J.F.G.: 'Incorporation of on-load tap changer transformers in low-voltage network planning'*IEEE PES Innov. Smart Grid Technol. Conf. Eur.*, 2017, pp. 1–6.
- 129 Navarro-Espinosa, A., Ochoa, L.F.: 'Increasing the PV hosting capacity of Lv networks: OLTC-fitted transformers vs. reinforcements'2015 *IEEE Power Energy Soc. Innov. Smart Grid Technol. Conf. ISGT 2015*, 2015, pp. 1–5.
- 130 Esslinger, P., Witzmann, R.: 'Regulated distribution transformers in low-voltage networks with a high degree of distributed generation'*IEEE PES Innov. Smart Grid Technol. Conf. Eur.*, 2012, pp. 1–7.
- 131 Stetz, T., Marten, F., Braun, M.: 'Improved low voltage grid-integration of photovoltaic systems in Germany'*IEEE Trans. Sustain. Energy*, 2013, **4**, (2), pp. 534–542.
- 132 Bradley, P., Leach, M., Torriti, J.: 'A review of the costs and benefits of demand response for electricity in the UK'*Energy Policy*, 2013, **52**, pp. 312–327.
- 133 Haque, A.N.M.M.: 'Smart Congestion Management in Active Distribution Networks'2017, (September), p. 184.
- 134 Version, D.: 'Power quality in distribution networks Power Quality in Distribution Networks ': (2017)
- 135 Das, C.K., Bass, O., Kothapalli, G., Mahmoud, T.S., Habibi, D.: 'Overview of energy storage systems in distribution networks: Placement, sizing, operation, and power quality'*Renew. Sustain.*

- Energy Rev.*, 2018, **91**, (November 2016), pp. 1205–1230.
- 136 Li, L., Ma, M., Xu, B., Liu, Z., Li, Y., Yang, H.: 'Power-quality of distribution networks with high penetrated intermittent distributed generation: A survey' *POWERCON 2014 - 2014 Int. Conf. Power Syst. Technol. Towar. Green, Effic. Smart Power Syst. Proc.*, 2014, (Powercon), pp. 2933–2939.
- 137 Sikorski, T., Rezmer, J.: 'Distributed Generation and Its Impact on Power Quality in Low-Voltage Distribution Networks, Power Quality Issues in Distributed Generation' *Intech open*, 2015, **2**, p. 64.
- 138 Chandra Mouli, G.R., Bauer, P., Wijekoon, T., Panosyan, A., Bärthlein, E.M.: 'Design of a power-electronic-assisted OLTC for grid voltage regulation' *IEEE Trans. Power Deliv.*, 2015, **30**, (3), pp. 1086–1095.
- 139 Kumar, D., Zare, F.: 'Harmonic Analysis of Grid Connected Power Electronic Systems in Low Voltage Distribution Networks' *IEEE J. Emerg. Sel. Top. Power Electron.*, 2016, **4**, (1), pp. 70–79.
- 140 Yang, H., Guerrero, J.M., Zhao, R., Zeng, Z.: 'Multi-functional distributed generation unit for power quality enhancement' *IET Power Electron.*, 2015, **8**, (3), pp. 467–476.
- 141 Yang, N.C., Chen, H.C.: 'Decomposed Newton algorithm-based three-phase power-flow for unbalanced radial distribution networks with distributed energy resources and electric vehicle demands' *Int. J. Electr. Power Energy Syst.*, 2018, **96**, (February 2017), pp. 473–483.
- 142 Mokryani, G., Majumdar, A., Pal, B.C.: 'Probabilistic method for the operation of three-phase unbalanced active distribution networks' *IET Renew. Power Gener.*, 2016, **10**, (7), pp. 944–954.
- 143 Dahal, S., Salehfar, H.: 'Impact of distributed generators in the power loss and voltage profile of three phase unbalanced distribution network' *Int. J. Electr. Power Energy Syst.*, 2016, **77**, pp. 256–262.
- 144 Ghatak, U., Mukherjee, V.: 'A fast and efficient load flow technique for unbalanced distribution system' *Int. J. Electr. Power Energy Syst.*, 2017, **84**, pp. 99–110.
- 145 Yaghoobi, J., Islam, M., Mithulananthan, N.: 'Analytical approach to assess the loadability of unbalanced distribution grid with rooftop PV units' *Appl. Energy*, 2018, **211**, (December 2015), pp. 358–367.
- 146 Zhai, H.F., Yang, M., Chen, B., Kang, N.: 'Dynamic reconfiguration of three-phase unbalanced distribution networks' *Int. J. Electr. Power Energy Syst.*, 2018, **99**, (December 2017), pp. 1–10.
- 147 Berg, R., Hawkins, E.S., Pleines, W.W.: 'Mechanized Calculation of Unbalanced Load Flow on Radial Distribution Circuits' *IEEE Trans. Power Appar. Syst.*, 1967, **PAS-86**, (4), pp. 415–421.
- 148 Wu, W.C., Zhang, B.M.: 'A three-phase power flow algorithm for distribution system power flow based on loop-analysis method' *Int. J. Electr. Power Energy Syst.*, 2008, **30**, (1), pp. 8–15.
- 149 Alinjak, T., Pavic, I., Trupinic, K.: 'Improved three-phase power flow method for calculation of power losses in unbalanced radial distribution network' *CIRED - Open Access Proc. J.*, 2017, **2017**, (1), pp. 2361–2365.
- 150 Alinjak, T., Pavić, I., Stojkov, M.: 'Improvement of backward/forward sweep power flow method by using modified breadth-first search strategy' *IET Gener. Transm. Distrib.*, 2017, **11**, (1), pp. 102–109.
- 151 Karagiannopoulos, S., Aristidou, P., Hug, G.: 'A centralised control method for tackling unbalances in active distribution grids' *20th Power Syst. Comput. PSCC 2018*, 2018.
- 152 Muruganatham, B., Selvam, M.M., Gnanadass, R., Padhy, N.P.: 'Energy loss reduction and load balancing through network reconfiguration in practical LV distribution feeder using GAMS' *2017 7th Int. Conf. Power Syst. ICPS 2017*, 2018, pp. 509–513.
- 153 Fetzer, D., Lammert, G., Gehler, S., Hegemann, J., Schmoll, R., Braun, M.: 'Integration of voltage dependent power injections of distributed generators into the power flow by using a damped Newton method' *Int. J. Electr. Power Energy Syst.*, 2018, **99**, (July 2017), pp. 695–705.
- 154 Hakim, L., Wahidi, M., Murdika, U., Milano, F., Kubokawa, J., Yorino, N.: 'A three-phase power flow analysis for electrical power distribution system with low voltage profile' *ICITACEE 2015 - 2nd Int. Conf. Inf. Technol. Comput. Electr. Eng. Green Technol. Strength. Inf. Technol. Electr. Comput. Eng. Implementation, Proc.*, 2016, pp. 303–308.
- 155 Sereeter, B., Vuik, K., Witteveen, C.: 'Newton power flow methods for unbalanced three-phase distribution networks' *Energies*, 2017, **10**, (10).
- 156 Husain, T., Khan, M., Ansari, M.: 'Power Flow Analysis of Distribution System' 2016, pp. 4058–4065.
- 157 Chen, T., Chen, M., Kotas, P., Chebli, E.A.: '1146 E E E Transactions on' *Distribution*, 1991, **6**, (3), pp. 1146–1152.
- 158 Teng, J.H.: 'A modified Gauss-Seidel algorithm of three-phase power flow analysis in distribution networks' *Int. J. Electr. Power Energy Syst.*, 2002, **24**, (2), pp. 97–102.
- 159 Chen, T.H., Yang, N.C.: 'Loop frame of reference based three-phase power flow for unbalanced radial distribution systems' *Electr. Power Syst. Res.*, 2010, **80**, (7), pp. 799–806.
- 160 Huang, W.T.: 'Study on the operation of a low-voltage AC microgrid with multiple distributed generations' *WSEAS Trans. Circuits Syst.*, 2010, **9**, (12), pp. 725–735.
- 161 Dugan, R.C., McDermott, T.E.: 'An open source platform for collaborating on smart grid research' *IEEE Power Energy Soc. Gen. Meet.*, 2011, (Ivvc), pp. 1–7.
- 162 Schneider, K.P., Chassin, D., Chen, Y., Fuller, J.C.: 'Distribution power flow for smart grid technologies' *2009 IEEE/PES Power Syst. Conf. Expo. PSCE 2009*, 2009, pp. 1–7.
- 163 Verma, R., Sarkar, V.: 'Application of Modified Gauss-Zbus Iterations for Solving the Load Flow Problem in Active Distribution Networks' *Electr. Power Syst. Res.*, 2019, **168**, (October 2018), pp. 8–19.
- 164 Costa, VM; Martins, Nelson; Pereira, J.L.: 'Developments in the Newton Raphson power flow formulation based on current injections' *IEEE Trans. Power Syst.*, 1999, **14**, (4), pp. 1320–1326.
- 165 Garcia, P.A.N., Member, S., Pereira, J.L.R., et al.: 'Three-Phase Power Flow Calculations Using the Current Injection Method' 2000, **15**, (2), pp. 508–514.
- 166 Garcia, P.A.N., Pereira, J.L.R., Carneiro, S., Vinagre, M.P., Gomes, F. V.: 'Improvements in the representation of PV buses on three-phase distribution power flow' *IEEE Trans. Power Deliv.*, 2004, **19**, (2), pp. 894–896.
- 167 da Costa, V.M., de Oliveira, M.L., Guedes, M.R.: 'Developments in the analysis of unbalanced three-phase power flow solutions' *Int. J. Electr. Power Energy Syst.*, 2007, **29**, (2), pp. 175–182.
- 168 Araujo, L.R. De, Penido, D.R.R., Júnior, S.C., Pereira, J.L.R., Garcia, P.A.N.: 'Comparisons between the three-phase current injection method and the forward/backward sweep method' *Int. J. Electr. Power Energy Syst.*, 2010, **32**, (7), pp. 825–833.
- 169 Ghatak, U., Mukherjee, V.: 'An improved load flow technique based on load current injection for modern distribution system' *Int. J. Electr. Power Energy Syst.*, 2017, **84**, pp. 168–181.
- 170 Benato, R., Paolucci, A., Turri, R.: 'Power flow solution by a complex admittance matrix method' *Eur. Trans. Electr. Power*,

- 2001, **11**, (3), pp. 181–188.
- 171 Sunderland, K., Coppo, M., Conlon, M.F., Turri, R.: ‘Application of a correction current injection power flow algorithm to an unbalanced 4-wire distribution network incorporating TN-C-S earthing’*Proc. Univ. Power Eng. Conf.*, 2013, pp. 1–6.
- 172 Sunderland, K., Coppo, M., Conlon, M., Turri, R.: ‘A correction current injection method for power flow analysis of unbalanced multiple-grounded 4-wire distribution networks’*Electr. Power Syst. Res.*, 2016, **132**, pp. 30–38.
- 173 Guosso, G., Maffezzoni, P., Zhang, Z., Daniel, L.: ‘Probabilistic load flow methodology for distribution networks including loads uncertainty’*Int. J. Electr. Power Energy Syst.*, 2019, **106**, (March 2018), pp. 392–400.
- 174 Temiz, A., Guven, A.N.: ‘Assessment of impacts of Electric Vehicles on LV distribution networks in Turkey’*2016 IEEE Int. Energy Conf. ENERGYCON 2016*, 2016, pp. 1–6.
- 175 Klonari, V., Meersman, B., Bozalakov, D., *et al.*: ‘A probabilistic framework for evaluating voltage unbalance mitigation by photovoltaic inverters’*Sustain. Energy, Grids Networks*, 2016, **8**, pp. 1–11.
- 176 Marah, B., Ekwue, A.O.: ‘Probabilistic Load Flows’*2015 50th Int. Univ. Power Eng. Conf.*, 2015, (1), pp. 1–6.
- 177 Diop, F., Hennebel, M.: ‘Probabilistic load flow methods to estimate impacts of distributed generators on a LV unbalanced distribution grid’*2017 IEEE Manchester PowerTech, Powertech 2017*, 2017, pp. 1–6.
- 178 Chakavorty, J., Gupta, M.: ‘A New Method of Load-Flow Solution of Radial Distribution Networks’*Int. J. Electron. Commun. Eng.*, 2012, **5**, (1), pp. 9–22.
- 179 Derakhshandeh, S.Y., Pourbagher, R., Kargar, A.: ‘A novel fuzzy logic Levenberg-Marquardt method to solve the ill-conditioned power flow problem’*Int. J. Electr. Power Energy Syst.*, 2018, **99**, (February), pp. 299–308.
- 180 Cao, S., Fu, L., Wang, X., Liu, H.: ‘Research on optimal access of fluctuation source and storage device in DN based on statistical and fuzzy theory’*2016 IEEE 8th Int. Power Electron. Motion Control Conf. IPEMC-ECCE Asia 2016*, 2016, pp. 201–206.
- 181 Delgado, C., Domínguez-Navarro, J.A.: ‘Point estimate method for probabilistic load flow of an unbalanced power distribution system with correlated wind and solar sources’*Int. J. Electr. Power Energy Syst.*, 2014, **61**, pp. 267–278.
- 182 Zhang, H., Xu, Y.: ‘Probabilistic load flow calculation by using probability density evolution method’*Int. J. Electr. Power Energy Syst.*, 2018, **99**, (13), pp. 447–453.
- 183 Di Fazio, A.R., Russo, M., Valeri, S., De Santis, M.: ‘Linear method for steady-state analysis of radial distribution systems’*Int. J. Electr. Power Energy Syst.*, 2018, **99**, (February), pp. 744–755.
- 184 Jeong, M.G., Kim, Y.J., Moon, S. Il, Hwang, P.I.: ‘Optimal voltage control using an equivalent model of a low-voltage network accommodating inverter-interfaced distributed generators’*Energies*, 2017, **10**, (8).
- 185 Hussain, I., Ali, S.M., Khan, B., *et al.*: ‘Stochastic Wind Energy Management Model within smart grid framework: A joint Bi-directional Service Level Agreement (SLA) between smart grid and Wind Energy District Prosumers’*Renew. Energy*, 2018, **134**, pp. 1017–1033.
- 186 Badran, O., Mekhilef, S., Mokhlis, H., Dahalan, W.: ‘Optimal reconfiguration of distribution system connected with distributed generations: A review of different methodologies’*Renew. Sustain. Energy Rev.*, 2017, **73**, (August 2015), pp. 854–867.
- 187 Mishra, S., Das, D., Paul, S.: ‘A comprehensive review on power distribution network reconfiguration’*Energy Syst.*, 2017, **8**, (2), pp. 227–284.
- 188 Susic, D., Stefanov, P.: ‘Reconfiguration of the three phase unbalanced distribution network’*2016*, pp. 1–8.
- 189 Borozan, V.: ‘Minimum loss reconfiguration of unbalanced distribution networks’*IEEE Power Eng. Rev.*, 1997, **17**, (1), p. 64.
- 190 Li, H., Mao, W., Zhang, A., Li, C.: ‘An improved distribution network reconfiguration method based on minimum spanning tree algorithm and heuristic rules’*Int. J. Electr. Power Energy Syst.*, 2016, **82**, pp. 466–473.

Appendix

Table 3. Voltage of LV networks and associated diagram in various countries around the world[19]

Country	Domestic (V)	Commercial (V)	Industrial (V)
Australia	415/240[a]* 240[b]	415/240[a] 440/250[a]	415/240[a] ,440/250[a]
Austria	230[b]	380/220[a] 220[b]	380/220[a]
China	220[b]	380/220[a] 220[b]	380/220[a] 220[b]
Denmark	400/230[a]	400/230[a]	400/230[a]
Germany	400/230[a] 230[b]	400/230[a] 230[b]	400/230[a]
India	440/250[a] 230[b]	440/250[a] 230[b]	440/250[a] 400/230[a]
Jordan	380/220[a] 230[b]	380/220[a]	400/230[a]

UK	230 and 220 [b]	400/230[a] 380/220[a]	400/230[a] 380/220[a]
USA(California)	120/240[e]	120/240[d]	120/240[d]
USA(Florida)	120/240[d] 120/208[a]	120/240[e] 120/208[a]	408/277[a]
USA (New York)	120/240[e] 120/208[a]	120/240[e] 120/208[a]	270/280[a]
Saudi Arabia	220/127[a]	220/127[a] 380/220 [a]	380/220 [a]
Iran	220[b]	380/220[a]	380/220[a]
South Korea	220[b]	380/220[a]	380/220[a]

* The letter refers to the associated circuit which shows in **Fig.5(a and b) and Fig.6(c-f)**