

## Purdue University Purdue e-Pubs

---

Indiana Local Technical Assistance Program  
(LTAP) Publications

Indiana Local Technical Assistance Program  
(LTAP)

---

7-2011

# Estimating Highway Maintenance Work, Fifth Edition

Ohio Department of Transportation

Indiana LTAP  
[inltap@ecn.purdue.edu](mailto:inltap@ecn.purdue.edu)

Follow this and additional works at: <http://docs.lib.purdue.edu/inltappubs>

 Part of the [Civil Engineering Commons](#)

---

### Recommended Citation

Ohio Department of Transportation and LTAP, Indiana, "Estimating Highway Maintenance Work, Fifth Edition" (2011). *Indiana Local Technical Assistance Program (LTAP) Publications*. Paper 2.  
<http://docs.lib.purdue.edu/inltappubs/2>

This document has been made available through Purdue e-Pubs, a service of the Purdue University Libraries. Please contact [epubs@purdue.edu](mailto:epubs@purdue.edu) for additional information.

# **Estimating Highway Maintenance Work**

**July 2011  
SP-1-2011**

compiled by

**The Ohio Department of Transportation**

updated by

**The Indiana LTAP Center**

**Indiana LTAP Center  
Purdue University School of Civil Engineering  
Indiana LTAP Center  
3000 Kent Avenue  
West Lafayette, Indiana 47906**

**Telephone: 765.494.2164  
Toll Free in Indiana: 1.800.428.7639  
Facsimile: 765.496.1176**

This document is disseminated under the sponsorship of the Indiana LTAP Center at Purdue University in the interest of information exchange. Purdue University and the Indiana LTAP Center assume no liability for its contents or use thereof. Purdue University and the Indiana LTAP Center do not endorse products or manufacturers. Trademarks or manufacturers names may appear herein only because they are considered essential to the objective of this document. The contents of this report reflect the views of the authors, who are responsible for the facts and accuracy of the data presented herein. The contents do not necessarily reflect the official policy of Purdue University or the Indiana LTAP Center. This report does not constitute a standard, specification, or regulation.

## Estimating Highway Maintenance Work

Estimating amounts of materials, work done, size of crews, or number of trucks needed for road maintenance requires the skill of working with **NUMBERS** and **MEASUREMENTS**. By using addition, subtraction, multiplication, division and some basic rules, you can do some figuring ahead of time and make your crews look better. People feel better about themselves when they're doing a good job, their friends do too, and so does the motoring public.

**NUMBERS** play an important part in the everyday affairs of everybody. Ever since the beginning of the human race, people have been asking questions: How much? How many? How far? How long? and so on. To answer these questions, we need numbers and units of measurement.

**MEASURE** refers to standard values – 12 inches per foot, 2000 pounds per ton, 27 cubic feet per cubic yard. **MEASUREMENT** means the actual size of something – length, width, area, volume or weight. **RATE** involves two kinds of measurement – gallons per square yard, pounds per 2-lane mile, miles per gallon.

A pocket calculator saves the time involved in long-hand calculations and worrying about “why” things are true. A lot of “how” questions can be answered by doing things with numbers. To most of you these exercises will be easy but for others they may take more time and effort. If the latter is the case, an old saying may be comforting – “All things are difficult before they are easy”.

An Appendix is provided to help with lengths, areas, volumes, rates, equivalents, and rules. You'll get acquainted with the **TABLES** and **RULES** as you run through the sample problems. The rules and tables used to solve the sample problems are listed in the left-hand margin. The table will help you change sizes or measurements into the same units before you punch the numbers into your calculator.

A number by itself does not have much meaning. Everyone should get in the habit of writing the units of measure with the numbers. Abbreviations are O.K.

## Problem Index

Area of an Intersection.....	22
Area-Pipe .....	8
Asphalt Patches.....	25
Asphalt Quantities.....	34, 39
Berm Aggregate .....	5, 13
Berm Conditioning.....	29
Blacktop .....	6, 12, 16
Bridge Deck Repair.....	27
Centerline Pavement Markings.....	34
Chip & Seal.....	21
Concrete Batching.....	31
Cover Aggregate .....	3
Crack Sealer .....	29
Culvert Installation.....	32
Culvert Sizes .....	28
Ditch Grade .....	20
Drag Patching.....	32
Dumped Rock .....	39
Edge Line Painting.....	33
Full-Depth Pavement Repairs.....	8
Grass Seeding.....	14, 18
Guardrail Repair.....	16
Lane Closure .....	34
Liquid Calcium Chloride .....	23, 24
Mowing.....	1, 2, 15, 30
Person-Days .....	27
Prime, Tack, Seal Coat.....	2, 3
Road Salt Application.....	4, 18
Salt Shed Capacity .....	28
Salt Spreader Calibration .....	10
Shoulder Fill.....	11, 19
Shoulder Widening .....	35
Slope-Roadway .....	9

Straight Line Mileage .....	1, 33, 36
Tank Capacity .....	30
Truck Capacity.....	11, 17
Volume-Backfill .....	7
Volume-Fill.....	12, 17
Volume-Pipe .....	7
Volume-Stockpile .....	5, 15, 26
Volume-Tank .....	14

**STRAIGHT LINE MILAGE**

1. How far is it between a point 0.3 of a mile east of Mile Marker 9 and another point 0.2 of a mile west of Mile Marker 7? (Give the answer in miles, feet and yards.)

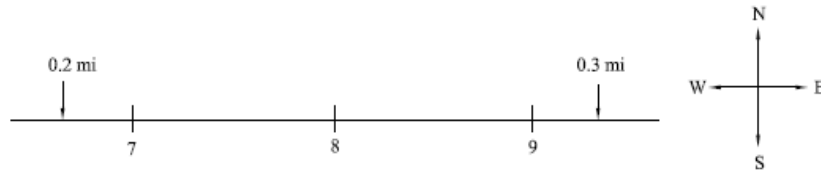

$$\text{Distance} = 0.2 + 2 + 0.3 \text{ mi.} = \underline{\underline{2.5 \text{ mi.}}}$$

$$2.5 \text{ mi.} \times \frac{5,280 \text{ ft.}}{\text{mi.}} = \underline{\underline{13,200 \text{ ft.}}}$$

$$\frac{13,200 \text{ ft.}}{3 \text{ ft./yd.}} = \underline{\underline{4,400 \text{ yds.}}}$$

Table 3

**MOWING**

2. A swath mile is considered to be 5 feet wide. How many square feet in a swath mile? How many acres?

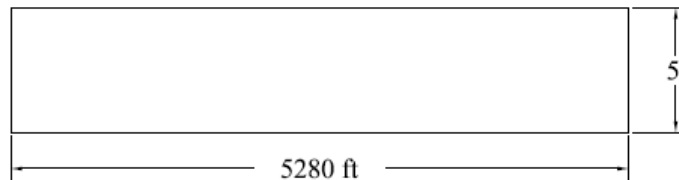

$$\text{Area} = 5 \text{ ft.} \times 5,280 \text{ ft.} = \underline{\underline{26,400 \text{ sq. ft.}}}$$

Table 3

Table 7

$$\text{Acreage} = \frac{26,400 \text{ sq. ft.}}{43,560 \frac{\text{sq. ft.}}{\text{acre}}} = \underline{\underline{0.606 \text{ acres}}} = \underline{\underline{0.61 \text{ acres}}} = \underline{\underline{0.6 \text{ acres}}}$$

MOWING	
Table 3	<p>3. A highway worker mows from SLM 15.8 to SLM 24.7 and makes 4 passes with an 18 ft. wide gang mower. How many swath miles has he mowed? (Swath mile = 26,400 sq. ft. = 0.61 acres.)</p> <p><i>Length = SLM 24.7 – SLM 15.8 = 8.90 mi.</i></p> <p><i>Width = 4 × 18 ft. = 72 ft.      8.9 mi. × <math>\frac{5280 \text{ ft.}}{\text{mi.}}</math> = 46,992 ft.</i></p> <p><i>Area = 72 ft. × 46,992 ft. = 3,383,424 sq. ft.</i></p> <p style="text-align: center;"><math>\frac{3,383,424 \text{ sq. ft.}}{26,400 \text{ sq. ft.} / \text{swath mi.}} = \underline{\underline{128.16 \text{ swath mi.}}}</math></p>
PRIME, TACK, SEAL COAT	
Table 3	<p>4. How many gallons of liquid asphalt will be required to cover a pavement surface, 24 ft. wide, from SLM 4.55 to SLM 7.29 at a rate of 0.2 gal./sq. yd.?</p> <p><i>Length = SLM 7.29 – SLM 4.55 = 2.74 mi.</i></p> <p style="text-align: center;"><math>2.74 \text{ mi.} \times 5,280 \frac{\text{ft.}}{\text{mi.}} = 14,467.2 \text{ ft.}</math></p> <p><i>Width = 24 ft.</i></p>
Table 7	<p><i>Area = 14,467.2 ft. × 24 ft. = <math>\frac{347,212.80 \text{ sq. ft.}}{9 \frac{\text{sq. ft.}}{\text{sq. yd.}}} = 38,579 \text{ sq. yd.}</math></i></p> <p><i>Tack = 38,579.20 sq. yd. × <math>\frac{0.2 \text{ gal.}}{\text{sq. yd.}} = \underline{\underline{7,715.84 \text{ gal.}}}</math></i></p>

PRIME, TACK, SEAL COAT	
Rule 14	<p>5. How many lane-miles (12 ft. X 1 mile) should a 1,000 gal. distributor cover at the rate of 0.2 gal./sq. yd.?</p> $\text{Coverage} = 1,000 \text{ gal.} \div \frac{0.2 \text{ gal.}}{\text{sq. yd.}} = 5,000 \text{ sq. yd.}$
Table 3, 7	$\text{Lane mi.} = 12 \text{ ft.} \times 5,280 \text{ ft.} = \frac{63,360 \text{ sq. ft.}}{9 \frac{\text{sq. ft.}}{\text{sq. yd.}}} = 7,040 \text{ sq. yd.}$ $\# \text{ lane mi.} = \frac{5,000 \text{ sq. yd.}}{7,040 \text{ sq. yd.} / \text{mi.}} = \underline{\underline{0.71 \text{ mi.}}}$
COVER AGGREGATE	
	<p>6. How many tons of cover aggregate will be required for a shoulder seal job, 4 ft. wide both sides, on a 2-lane project, 5.8 miles long? (Assume an application rate of 25 lbs./sq. yd.)</p> <div style="text-align: center;"> </div>
Table 3	$\text{Length} = 5.8 \text{ mi.} \times 5,280 \frac{\text{ft.}}{\text{mi.}} = 30,624 \text{ ft.}$ $\text{Width} = 2 \times 4 \text{ ft.} = 8 \text{ ft.}$
Table 7	$\text{Area} = 8 \text{ ft.} \times 30,624 \text{ ft.} = \frac{244,992 \text{ sq. ft.}}{9 \frac{\text{sq. ft.}}{\text{sq. yd.}}} = 27,221.3 \text{ sq. yd.}$
Table 5	$\text{Cover Agg.} = 27,221.3 \text{ sq. yd.} \times \frac{25 \text{ lbs.}}{\text{sq. yd.}} = 680,533.33 \text{ lbs.}$ $\frac{680,533.33 \text{ lbs.}}{2,000 \frac{\text{lbs.}}{\text{ton}}} = \underline{\underline{340.3 \text{ ton}}}$



ROAD SALT APPLICATION

7. How many 2-lane miles of road will be covered by a truck load of salt treated sand weighing 8 tons with an application rate of 600 lbs. per 2-lane mile?

$$\text{Weight} = 8 \text{ tons} \times 2,000 \frac{\text{lbs.}}{\text{ton}} = 16,000 \text{ lbs.}$$

$$\text{Application Rate} = \frac{600 \text{ lbs.}}{2 - \text{lane mi.}}$$

$$\text{No. of lane miles} = \frac{16,000 \text{ lbs.}}{600 \text{ lbs.} / 2 - \text{lane mi.}} = \underline{\underline{26.7 (2 - lane mi.)}}$$

ROAD SALT APPLICATION

8. A truck applies salt at the rate of 600 lbs. per 2-lane mile from M.P. 2.2 to M.P. 32.0. How many tons of salt did he use?

$$\text{Length} = M.P. 32 - M.P. 2.2 = 29.80 \text{ mi.}$$

$$\frac{600 \text{ lbs.}}{\text{mi.}} \times 29.80 \text{ mi.} = 17,880 \text{ lbs.}$$

$$\frac{17,880 \text{ lbs}}{2,000 \frac{\text{lbs.}}{\text{ton}}} = \underline{\underline{8.94 \text{ ton}}}$$

Table 5

**BERM AGGREGATE**

9. How many cubic yards of berm aggregate will be required to level up a berm from SLM 9.31 to SLM 7.18 in accordance with the following cross section? Change to tons using a rate of 2 tons per cu. yd.

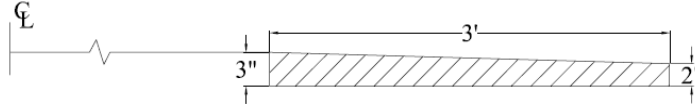

$$\frac{3 \text{ in.}}{12 \frac{\text{in.}}{\text{ft.}}} = 0.25 \text{ ft.}$$

$$\frac{2 \text{ in.}}{12 \frac{\text{in.}}{\text{ft.}}} = 0.167 \text{ ft.}$$

Rule 3

$$\text{Area (Cross Section)} = 3 \text{ ft.} \times \left( \frac{0.25 \text{ ft.} + 0.167 \text{ ft.}}{2} \right) = 0.626 \text{ sq. ft.}$$

$$\text{Length} = \text{SLM } 9.31 - \text{SLM } 7.18 = 2.13 \text{ miles}$$

$$2.13 \text{ mi.} \times \frac{5,280 \text{ ft.}}{\text{mi.}} = 11,246.4 \text{ ft.}$$

Rule 8

$$\text{Volume} = 11,246.4 \text{ ft.} \times 0.626 \text{ sq. ft.} = \frac{7,040.2 \text{ cu. ft.}}{27 \frac{\text{cu. ft.}}{\text{cu. yd.}}} = \underline{\underline{260.7 \text{ cu. yd.}}}$$

Table 4

$$\text{Tonage} = 260.7 \text{ cu. yd.} \times \frac{2 \text{ ton}}{\text{cu. yd.}} = \underline{\underline{521.4 \text{ tons}}}$$

**VOLUME – STOCKPILE**

10. How many cu. yd. of stone in a cone-shaped stockpile that is 45 ft. in diameter and 16 ft. high?

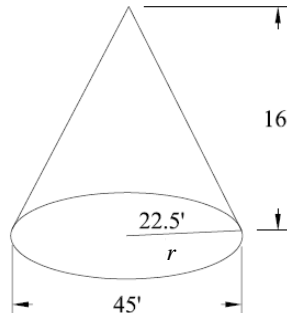

Rule 9

$$\text{Volume} = \frac{3.14 \times r \times r \times h}{3}$$

$$\begin{aligned} \text{Volume} &= \frac{3.14 \times 22.5 \text{ ft.} \times 22.5 \text{ ft.} \times 16 \text{ ft.}}{3} \\ &= 8,478 \text{ cu. ft.} \end{aligned}$$

Table 4

$$r = \frac{45 \text{ ft.}}{2} = 22.5 \text{ ft.}$$

$$\frac{8,478 \text{ cu. ft.}}{27 \frac{\text{cu. ft.}}{\text{cu. yd.}}} = \underline{\underline{314 \text{ cu. yd.}}}$$

**BLACKTOP**

11. How many tons of asphalt concrete (blacktop) overlay will be needed to cover a section of road from SLM 4.55 to 7.29 that is 24 ft. wide and 1 in. thick? (1 cu. yd. of asphalt weighs 2 tons)

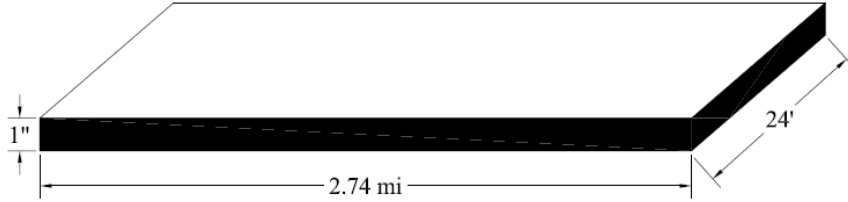

Table 3

$$\text{Length} = 2.74 \text{ mi.} \times \frac{5,280 \text{ ft.}}{\text{mi.}} = 14,467.20 \text{ ft.}$$

$$\text{Thickness} = \frac{1 \text{ in.}}{12 \text{ in./ft.}} = 0.0833 \text{ ft.}$$

Rule 6

$$\text{Volume} = 24 \text{ ft.} \times 14,467.20 \text{ ft.} \times 0.0833 \text{ ft.} = 28,922.83 \text{ cu. ft.}$$

Table 4

$$\frac{28,922.83 \text{ cu. ft.}}{27 \frac{\text{cu. ft.}}{\text{cu. yd.}}} = 1,071.22 \text{ cu. yd.}$$

$$1,071.22 \text{ cu. yd.} \times \frac{2 \text{ ton}}{\text{cu. yd.}} = \underline{\underline{2,142.4 \text{ ton}}}$$

**VOLUME – BACKFILL**

12. How many cu. yd. of backfill would be required for a culvert trench that is 30 ft. wide from berm edge to berm edge, with a 2:1 slope (each side), 5 ft. deep and 6 ft. in length measured along the centerline? Disregard volume occupied by the pipe.

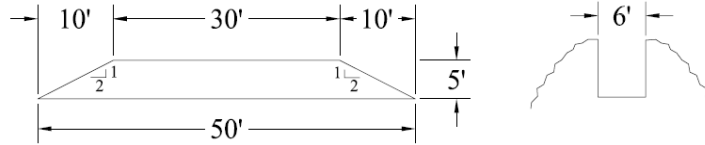

Rule 11

*Slope 2 : 1 ~ 2 × 5 ft. = 10 ft. (run on each side)*

Rule 8

$$Volume = \frac{30 \text{ ft.} + 50 \text{ ft.}}{2} \times 5 \text{ ft.} \times 6 \text{ ft.} = 1,200 \text{ cu. ft.}$$

Table 4

$$Volume = \frac{1,200 \text{ cu. ft.}}{27 \text{ cu. ft.} / \text{cu. yd.}} = \underline{\underline{44.4 \text{ cu. yd.}}}$$

**VOLUME – PIPE**

13. How much volume would be deducted for a 36-inch (outside diameter) pipe from the backfill calculated for the culvert trench in Problem No. 12.

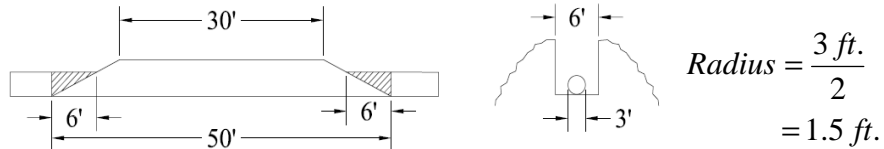

Rule 11

$$Slope \ 2 : 1 \sim 2 \times \frac{36 \text{ in.}}{12 \text{ in.} / \text{ft.}} = 6.0 \text{ ft.}$$

Rule 17

$$Volume \ of \ 50 \ \text{ft.} \ \text{Pipe} = 3.14 \times 1.5 \ \text{ft.} \times 1.5 \ \text{ft.} \times 50 \ \text{ft.} = 353.25 \ \text{cu. ft.}$$

*Deduct 2 pieces of pipe near end =*

$$2 \times \left[ \frac{1}{2} \times 3.14 \times 1.5 \ \text{ft.} \times 1.5 \ \text{ft.} \times 6 \ \text{ft.} \right] = 42.39 \ \text{cu. ft.}$$

$$Volume \ of \ Pipe \ Backfill = 353.25 - 42.39 = 310.86 \ \text{cu. ft.}$$

Table 4

$$Volume \ (\text{cu. yd.}) = \frac{310.86 \ \text{cu. ft.}}{27 \ \text{cu. ft.} / \text{cu. yd.}} = \underline{\underline{11.51 \ \text{cu. yd.}}}$$

AREA – PIPE	
	<p>14. What is the comparison of the area of two 12-inch pipes versus one 24-inch pipe? (Diameters are inside dimensions.)</p>
Table 3	$D = 12 \text{ in.} = 1 \text{ ft.}$ $r = 6 \text{ in.} = 0.5 \text{ ft.}$
Rule 5	$Area(1 - 12 \text{ in.}) = 3.14 \times r \times r = 3.14 \times 0.5 \text{ ft.} \times 0.5 \text{ ft.} = 0.785 \text{ sq. ft.}$  $Area(2 - 12 \text{ in.}) = 2 \times 0.785 \text{ sq. ft.} = \underline{\underline{1.57 \text{ sq. ft.}}}$
Rule 5	$Area(1 - 24 \text{ in.}) = 3.14 \times 1 \text{ ft.} \times 1 \text{ ft.} = \underline{\underline{3.14 \text{ sq. ft.}}}$  <p>Therefore, 1 – 24 in. pipe has <math>\cong</math> twice the capacity of 2 – 12 in. pipes</p>
FULL – DEPTH PAVEMENT REPAIRS	
	<p>15. How many cubic yards of concrete are required to make a 12 in. deep pavement repair, 10 ft. long and 12 ft. wide?</p>
Rule 6	$Volume = 12 \text{ ft.} \times 10 \text{ ft.} \times 1 \text{ ft.} = 120 \text{ cu. ft.}$
Table 4	$\frac{120 \text{ cu. ft.}}{27 \frac{\text{cu. ft.}}{\text{cu. yd.}}} = \underline{\underline{4.44 \text{ cu. yd.}}}$

SLOPE – ROADWAY

16. What is the HORIZONTAL distance from point “A” to point “B” in the following drawing using a 3:1 slope?

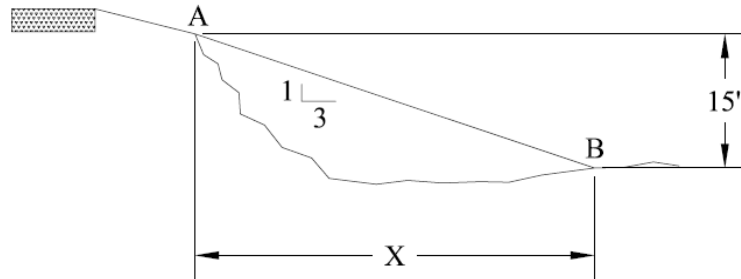

Rule 11

$$X = 15 \text{ ft.} \times 3 = \underline{\underline{45 \text{ ft.}}}$$

(or)

Using Ratio's

$$\frac{1}{3} = \frac{15 \text{ ft.}}{X}$$

$$X = \frac{3 \times 15 \text{ ft.}}{1} = \underline{\underline{45 \text{ ft.}}}$$

SALT SPREADER CALIBRATION

17. A large sheet of canvas is slipped under the stream of salt for 5 turns of the auger shaft. The net weight of the salt is 87.3 pounds. What is the average amount of salt discharged per turn?

$$\frac{87.3 \text{ lbs. salt}}{5 \text{ turns}} = 17.46 \frac{\text{lbs. salt}}{\text{turn}}$$

SALT SPREADER CALIBRATION

18. Determine the auger drive shaft speed in Revolutions Per Minute (RPM) when the shaft turns 5.6 times in 60 seconds.

$$60 \text{ seconds} = 1 \text{ min.}$$

$$\frac{5.6 \text{ revolutions}}{60 \text{ sec.}} = \frac{5.6 \text{ rev.}}{1 \text{ min.}} = \underline{\underline{5.6 \text{ RPM}}}$$

SALT SPREADER CALIBRATION

19. Determine the auger drive shaft speed in RPM when the shaft turns 6 times in 64 seconds.

$$\frac{64 \text{ sec.}}{60 \frac{\text{sec.}}{\text{min.}}} = 1.067 \text{ min.}$$

$$\frac{6 \text{ revolutions}}{1.067 \text{ min.}} = \underline{\underline{5.625 \text{ RPM}}}$$

SALT SPREADER CALIBRATION

20. When the shaft speed equals 10.5 RPM and the average amount of salt is 9.5 pounds per turn, what is the salt output per minute?

$$10.5 \frac{\text{rev.}}{\text{min.}} \times 9.5 \frac{\text{lbs.}}{\text{rev.}} = \underline{\underline{99.75 \frac{\text{lbs.}}{\text{min.}}}}$$

SALT SPREADER CALIBRATION

21. What is the salt output per mile (shaft speed = 20.2 RPM; pounds per turn = 9.5) and the truck speed is 20 miles per hour (MPH)?

$$\text{No. of Shaft Revolutions} = 20.2 \frac{\text{rev.}}{\text{min}} \times 60 \frac{\text{min.}}{\text{hr.}} = \underline{\underline{1,212 \frac{\text{rev.}}{\text{hr.}}}}$$

$$\text{Amt. of Salt} = 1,212 \frac{\text{rev.}}{\text{hr.}} \times 9.5 \frac{\text{lbs.}}{\text{rev.}} = \underline{\underline{11,514 \frac{\text{lbs. salt}}{\text{hr.}}}}$$

$$\text{Salt per mi.} = 11,514 \frac{\text{lbs.}}{\text{hr.}} \times \frac{1 \text{ hr.}}{20 \text{ mi.}} = \underline{\underline{575.7 \frac{\text{lbs. salt}}{\text{mile}}}}$$

**SHOULDER FILL**

22. You need to add 2 ft. and a 3:1 slope to a shoulder that is 4 ft. from the top of the pavement to the bottom of the ditch with a 2:1 slope. How many cubic yards of dirt will be needed for 1,000 linear ft. of pavement? (one side) (1 cu. yd. = 2 tons)

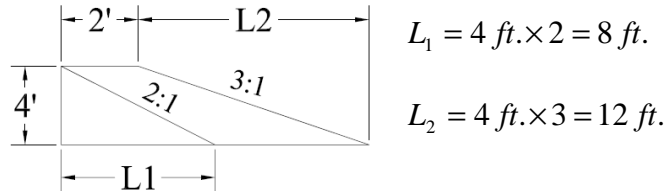

$$\text{Total Area} = (2 \text{ ft.} \times 4 \text{ ft.}) + \frac{1}{2} \times (4 \text{ ft.} \times 12 \text{ ft.}) = 32 \text{ sq. ft.}$$

$$\text{Existing Area} = \frac{1}{2} (4 \text{ ft.} \times 8 \text{ ft.}) = 16 \text{ sq. ft.}$$

$$\text{Fill Area} = 32 - 16 = 16 \text{ sq. ft.}$$

$$\text{Volume} = 16 \text{ sq. ft.} \times 1,000 \text{ ft.} = 16,000 \text{ cu. ft.}$$

$$\frac{16,000 \text{ cu. ft.}}{27 \text{ cu. ft.} / \text{cu. yd.}} = \underline{\underline{592.6 \text{ cu. yd.}}}$$

$$592.6 \text{ cu. yd.} \times 2 \frac{\text{ton}}{\text{cu. yd.}} = \underline{\underline{1,185.2 \text{ ton}}}$$

**TRUCK CAPACITY**

23. How many cubic yards of material can a dump truck hold if the bed measures 10 ft. long by 7 ft. wide and is 36 inches high? (the bed is filled level) How many tons?

Table 3

$$\text{Height} = 36 \text{ in.} \div 12 \frac{\text{in.}}{\text{ft.}} = 3 \text{ ft.}$$

Rule 6

$$\text{Volume} = 10 \text{ ft.} \times 7 \text{ ft.} \times 3 \text{ ft.} = 210 \text{ cu. ft.}$$

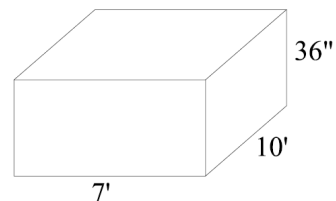

$$\frac{210 \text{ cu. ft.}}{27 \frac{\text{cu. ft.}}{\text{cu. yd.}}} = \underline{\underline{7.78 \text{ cu. yd.}}}$$

$$7.78 \text{ cu. yd.} \times 2 \frac{\text{ton}}{\text{cu. yd.}} = \underline{\underline{15.6 \text{ ton}}}$$

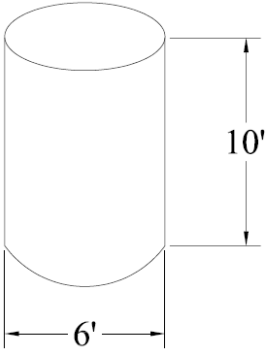

BLACKTOP	
	<p>24. If one ton of 404 Asphalt will cover 162 sq. ft., how many tons of 404 will be needed to cover a stretch of road that is 20 ft. wide, from SLM 14.63 to SLM 15.50?</p> <p>Tack coat is applied at a rate of 0.07 gal. per sq. yd. How many gallons of tack will be needed to cover this pavement?</p> <p><i>Length = SLM 15.50 – 14.63 = 0.87 mi.</i></p>
Table 3	$0.87 \text{ mi.} \times \frac{5,280 \text{ ft.}}{\text{mi.}} = 4,593.60 \text{ ft.}$
Rule 1	$\text{Area} = 20 \text{ ft.} \times 4,593.60 \text{ ft.} = 91,872 \text{ sq.ft.}$
Table 7	$\text{Area (sq. yd.)} = \frac{91,872 \text{ sq. ft.}}{9 \frac{\text{sq. ft.}}{\text{sq. yd.}}} = 10,208 \text{ sq. yd.}$
	$\text{Asphalt (req'd)} = 91,872 \text{ sq. ft.} \times \frac{1 \text{ ton}}{162 \text{ sq. ft.}} = \underline{\underline{567.1 \text{ ton}}}$
	$\text{Tack} = 10,208 \text{ sq. yd.} \times \frac{0.07 \text{ gal.}}{\text{sq. yd.}} = \underline{\underline{714.56 \text{ gal.}}}$
VOLUME	
	<p>25. How many cubic yards of stone would it take to fill a hole with a diameter of 6 ft. and a depth of 10 ft?</p>
Rule 5	$\text{Area} = \pi r^2 = 3.14 \times 3 \text{ ft.} \times 3 \text{ ft.} = 28.26 \text{ sq. ft.}$
Rule 6	$\text{Volume} = 28.26 \text{ sq. ft.} \times 10 \text{ ft.} = 282.60 \text{ cu. ft.}$
Table 4	$\frac{282.60 \text{ cu. ft.}}{27 \frac{\text{cu. ft.}}{\text{cu. yd.}}} = \underline{\underline{10.47 \text{ cu. yd.}}}$
	 <p>The diagram shows a 3D perspective of a cylinder representing a hole. The diameter of the circular top surface is labeled as 6 feet with a double-headed arrow. The vertical height of the cylinder is labeled as 10 feet with a double-headed arrow.</p>

**BERM AGGREGATE**

26. A section of roadway from SLM 6.43 to SLM 12.02 has just been resurfaced with 2 in. of 404 asphalt. You have to backup the new pavement with berm aggregate 2 ft. wide and the berm box can only pinch down to 1 in. on the outside edge. How many tons of berm aggregate will be needed if 1 cu. yd. weighs 3,800 lbs.? (both sides of the roadway must be done)



Table 3

$$\text{Length} = \text{SLM } 12.02 - 6.43 = 5.59 \text{ mi.}$$

$$5.59 \text{ mi.} \times \frac{5,280 \text{ ft.}}{\text{mi.}} = 29,515.20 \text{ ft.}$$

$$\frac{1 \text{ in.}}{12} = 0.083 \text{ ft.}$$

$$\frac{2 \text{ in.}}{12} = 0.167 \text{ ft.}$$

Rule 3

$$\text{Area (1 - side)} = 2 \text{ ft.} \times \left( \frac{0.083 \text{ ft.} + 0.167 \text{ ft.}}{2} \right) = 0.25 \text{ sq. ft.}$$

$$\text{Area (2 - side)} = 2 \times 0.25 \text{ sq. ft.} = 0.50 \text{ sq. ft.}$$

Rule 8

$$\text{Volume} = 29,515.20 \text{ ft.} \times 0.50 \text{ sq. ft.} = 14,757.6 \text{ cu. ft.}$$

Table 4

$$\frac{14,757.6 \text{ cu. ft.}}{27} = 546.58 \text{ cu. yd.}$$

$$\text{Weight} = 546.58 \text{ cu. yd.} \times \frac{3,800 \text{ lbs.}}{\text{cu. yd.}} = 2,077,004 \text{ lbs.}$$

$$2,077,004 \text{ lbs.} \div \frac{2,000 \text{ lbs.}}{\text{ton}} = \underline{\underline{1,038.5 \text{ ton}}}$$

**GRASS SEEDING**

27. Side ditches are set back on a stretch of a roadway and you need to seed the bare slopes. If the area is 2 mi. long and 15 ft. wide, how many pounds of grass seed is needed? (Assume you will use 10 lbs. of grass seed per acre, and both sides of the road will be seeded).



Table 3

$$\text{Length} = 2 \text{ mi.} \times \frac{5,280 \text{ ft.}}{\text{mi.}} = 10,560 \text{ ft.}$$

Rule 1

$$\text{Area} = 10,560 \text{ ft.} \times 2 \text{ sides} \times 15 \text{ ft.} = 316,800 \text{ sq. ft.}$$

Table 7

$$\frac{316,800 \text{ sq. ft.}}{43,560 \frac{\text{sq. ft.}}{\text{acre}}} = 7.27 \text{ acres}$$

$$\text{Seed} = 7.27 \text{ acres} \times \frac{10 \text{ lbs.}}{\text{acre}} = \underline{\underline{72.73 \text{ lbs.}}}$$

**VOLUME**

28. How many gallons of water will a cylindrical tank hold that is 12 ft. long and 6 ft. in diameter?

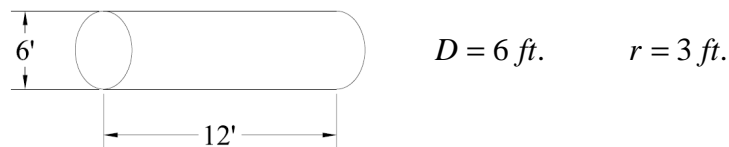

Rule 5

$$\text{End Area} = \pi r^2 = 3.14 \times 3 \text{ ft.} \times 3 \text{ ft.} = 28.26 \text{ sq. ft.}$$

Rule 17

$$\text{Volume} = 28.26 \text{ sq. ft.} \times 12 \text{ ft.} = 339.12 \text{ cu. ft.}$$

Table 6

$$339.12 \text{ cu. ft.} \times \frac{7.5 \text{ gal.}}{1 \text{ cu. ft.}} = \underline{\underline{2,543.4 \text{ gal.}}}$$

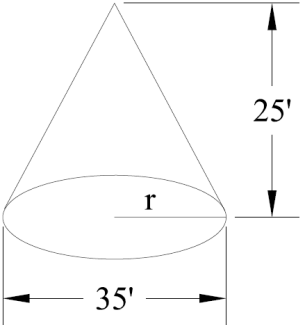
VOLUME	
	<p>29. How many cubic yards are in a stockpile of stone with a base diameter of 35 ft. and a height of 25 feet?</p>
Rule 9	 $r = \frac{35}{2} = 17.5 \text{ ft.} \quad h = 25 \text{ ft.}$ $\text{Volume} = \frac{\pi r^2 h}{3}$ $= \frac{3.14 \times 17.5 \text{ ft.} \times 17.5 \text{ ft.} \times 25 \text{ ft.}}{3}$ $= 8,013.54 \text{ cu. ft.}$
Table 4	$\frac{8,013.54 \text{ cu. ft.}}{27 \frac{\text{cu. ft.}}{\text{cu. yd.}}} = \underline{\underline{296.80 \text{ cu. yd.}}}$
MOWING	
	<p>30. One person is mowing with a 7 ½-ft. swath mower on U.S. 33. In 2 days, he mows an area 15 ft. wide and 4 miles long on both sides of the road. How many swath miles will be mowed after 2 days of mowing?</p>
Table 3	$\text{Length} = 4 \text{ mi.} \times \frac{5,280 \text{ ft.}}{\text{mi.}} = 21,120 \text{ ft.}$
Rule 1	$\text{Area} = 15 \text{ ft.} \times 21,120 \text{ ft.} = 316,800 \text{ sq. ft.}$ $\text{Swath mi.} = 5,280 \text{ ft.} \times 5 \text{ ft.} = 26,400 \text{ sq. ft.}$ $\text{Swath Miles} = \frac{316,800 \text{ sq. ft.}}{26,400 \frac{\text{sq. ft.}}{\text{swath mi.}}} = \underline{\underline{12.0 \text{ swath mi.}}}$

GUARDRAIL REPAIR	
31. How many guardrail panels (12'-6" long) and posts (6'-3" center to center) are required to repair a section of guardrail if an accident demolished 275 lineal ft. of TYPE 5 guardrail in the middle of a 1200 ft. run?	<p>12'-6"=12.5'                      6'-3"=6.25'</p> <p><math>Panels = 275 \text{ ft.} \div 12.5 \text{ ft./panel} = 22</math>      <math>add (2) = \underline{\underline{24 \text{ panels}}}</math></p> <p><math>Posts = 275 \text{ ft.} \div 6.25 \text{ ft.} = 44</math>                      <math>add (1) = \underline{\underline{45 \text{ posts}}}</math></p>
BLACKTOP	
32. A section of roadway will be widened 2 ft. on both sides from SLM 14.10 to SLM 21.84. The depth of the asphalt widening will be 6 in. How many tons of 402 Asphalt will be needed? (Assume 1 cu. yd. of 402 weighs 4,000 lbs.)	<p><math>Width = 2 \text{ ft.} \times 2 \text{ sides} = 4 \text{ ft.}</math></p> <p><math>Depth = 6 \text{ in.} = \frac{6 \text{ in.}}{12 \text{ in./ft.}} = 0.5 \text{ ft.}</math></p> <p><math>Length = 21.84 - 14.10 = 7.74 \text{ mi.}</math></p> <p><math>7.74 \text{ mi.} \times \frac{5,280 \text{ ft.}}{\text{mi.}} = 40,867.2 \text{ sq. ft.}</math></p> <p><math>Volume = 4 \text{ ft.} \times 0.5 \text{ ft.} \times 40,867.2 \text{ ft.} = 81,734.4 \text{ cu. ft.}</math></p> <p><math>= \frac{81,734.4 \text{ cu. ft.}}{27 \text{ cu. ft./cu.yd.}} = \underline{\underline{3,027.2 \text{ cu. yd.}}}</math></p> 

Table 3

TRUCK CAPACITY	
Table 5	<p>33. How many cubic yards of #8 stone can you legally haul if the maximum weight your single axle dump truck can scale is 30,000 lbs? How many tons? (Your truck weighs 12,000 lbs. empty)</p> $  \begin{array}{r}  30,000 \text{ lbs. (total)} \\  - 12,000 \text{ lbs. (truck)} \\  \hline  18,000 \text{ lbs. (load)}  \end{array}  $ $  \frac{18,000 \text{ lbs.}}{2,000 \frac{\text{lbs.}}{\text{ton}}} = \underline{\underline{9 \text{ ton}}}  $
VOLUME	
Rule 5  Rule 17	<p>34. How many cu. yd. of stone would it take to fill a hole with a diameter of 12'-3" and a depth of 10'-9".</p> $  \begin{array}{ll}  12'-3" = 12.25 \text{ ft.} & D = 12.25 \text{ ft.} \\  10'-9" = 10.75 \text{ ft.} & r = 6.125 \text{ ft.}  \end{array}  $ <p><i>End Area</i> = <math>\pi \times r \times r = 3.14 \times 6.125 \text{ ft.} \times 6.125 \text{ ft.} = 117.80 \text{ sq. ft.}</math></p> <p><i>Volume</i> = <math>117.80 \text{ sq. ft.} \times 10.75 \text{ ft.} = 1,266.35 \text{ cu. ft.}</math></p> $  \frac{1,266.35 \text{ cu. ft.}}{27 \frac{\text{cu. ft.}}{\text{cu. yd.}}} = \underline{\underline{46.90 \text{ cu. yd.}}}  $

**ROAD SALT APPLICATION**

35. A snowplow operator's route covers 20 mi. one way. If the application is a salt/sand mixture at a rate of 400 lbs. per mile and his truck holds 8 tons of salt/sand, will the driver be able to make (1) complete round trip without reloading? How much salt/sand mixture will he driver use to cover his route one way?

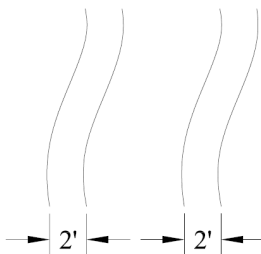
Table 5

$$8 \text{ ton} \times \frac{2,000 \text{ lbs.}}{\text{ton}} = 16,000 \text{ lbs.}$$

$$a) 40 \text{ mi.} \times \frac{400 \text{ lbs.}}{\text{mi.}} = 16,000 \text{ lbs.} \Rightarrow \underline{\underline{\text{yes}}}$$

$$b) \frac{16,000 \text{ lbs.}}{2} = \underline{\underline{8,000 \text{ lbs.}}}$$

**GRASS SEEDING**

36. How much grass seed would be required to cover the area shown below? Use an application rate of 3 lbs. per 1,000 sq. ft.

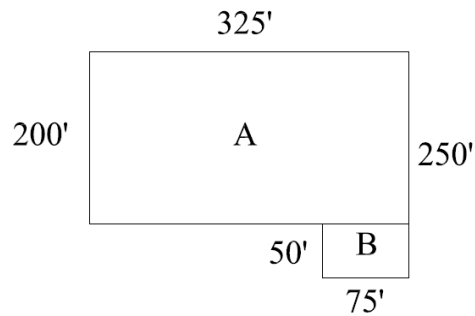

Rule 1

$$\text{Area} = \text{Area "A"} + \text{Area "B"}$$

$$= (200 \text{ ft.} \times 325 \text{ ft.}) + (50 \text{ ft.} \times 75 \text{ ft.})$$

$$= 65,000 \text{ sq. ft.} + 3,750 \text{ sq. ft.} = 68,750 \text{ sq. ft.}$$

$$\text{Seed} = 68,750 \text{ sq. ft.} \times \frac{3 \text{ lbs.}}{1,000 \text{ sq. ft.}} = \underline{\underline{206.25 \text{ lbs.}}}$$

**SHOULDER FILL**

37. (a) A fill must be placed along the edge of the roadway to eliminate a sharp drop-off. Shoulders must be placed 10 ft. wide from the edge of pavement with a slope of 1-in. per ft. The fill will then be toed out at a slope of 4:1. If the ditch is to end up being 6 ft. below the edge of pavement, how far from the edge of pavement will the slope extend?

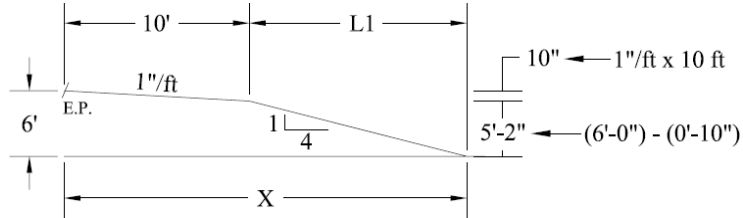

Table 3

$$5 \text{ ft.} - 2 \text{ in.} = \left( 5 \text{ ft.} + \frac{2 \text{ in.}}{12 \text{ in./ft.}} \right) = 5.167 \text{ ft.}$$

$$L_1 = 4 \times 5.167 \text{ ft.} = 20.67 \text{ ft.}$$

$$X = 10 \text{ ft.} + 20.67 \text{ ft.} = \underline{\underline{30.67 \text{ ft.}}}$$

(b) If the right-of-way will only permit putting the 6 ft. ditch 30 ft. from the centerline of the pavement, what would the slope be? (Pavement Width = 22 ft.)

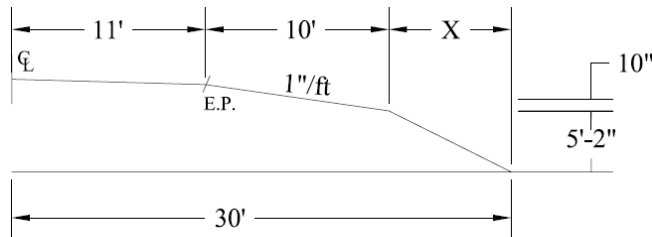

$$X = 30 \text{ ft.} - 10 \text{ ft.} - 11 \text{ ft.} = 9 \text{ ft.}$$

Rule 11

$$\text{Slope} = \frac{9 \text{ ft.}}{5 \text{ ft.} - 2 \text{ in.}} = \frac{9 \text{ ft.}}{5.167 \text{ ft.}} = \frac{1.74}{1} = \underline{\underline{1.74 : 1}}$$



**DITCH GRADE**

38. What are the grade elevations at 50 ft. intervals for a 600 ft. ditch whose outlet end is 3 ft. lower than the inlet end? (Assume an elevation for one end of the ditch)

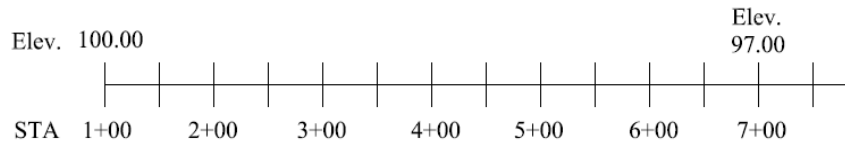

$$\text{Grade} = \frac{100 - 97}{600} = 0.005 \frac{\text{ft. fall in elev.}}{\text{ft. of dist.}}$$

$$\text{Decrease in elev. every 50 ft.} = 50 \text{ ft.} \times 0.005 \frac{\text{ft.}}{\text{ft.}} = \underline{\underline{0.25 \text{ ft.}}}$$

<u>STA</u>		<u>Elev.</u>
1+00		100.00 ft.
1+50	100 - 0.25 =	99.75 ft.
2+00	99.75 - 0.25 =	99.50 ft.
2+50	99.50 - 0.25 =	99.25 ft.
3+00	99.25 - 0.25 =	99.00 ft.
3+50	99.00 - 0.25 =	98.75 ft.
4+00	98.75 - 0.25 =	98.50 ft.
4+50	98.50 - 0.25 =	98.25 ft.
5+00	98.25 - 0.25 =	98.00 ft.
5+50	98.00 - 0.25 =	97.75 ft.
6+00	97.75 - 0.25 =	97.50 ft.
6+50	97.50 - 0.25 =	97.25 ft.
7+00	97.25 - 0.25 =	97.00 ft. ←

CHIP & SEAL

39. If you are going to chip & seal 1.5 miles of shoulders 2.5 feet wide on both sides of the roadway, how many sq. yds. will you be treating? How many gallons of bituminous material will you need? How many cu. yds. of #8 stone will you need? How many tons of stone will you need? (Assume a bituminous material rate of 0.30 gal. per sq. yd. and a stone spread rate of 0.00083 cu. yd. per sq. yd.)



Table 3

$$Length = 1.5 \text{ mi.} \times \frac{5,280 \text{ ft.}}{\text{mi.}} = 7,920 \text{ ft.}$$

Rule 1

$$Area = 2.5 \text{ ft.} \times 7,920 \text{ ft.} = 19,800 \text{ sq. ft.}$$

$$\frac{19,800 \text{ sq. ft.}}{9 \frac{\text{sq. ft.}}{\text{sq. yd.}}} = 2,200 \text{ sq. yd. to be treated}$$

$$Both / sides = 2,200 \text{ sq. yd.} \times 2 = \underline{\underline{4,400 \text{ sq. yd.}}}$$

$$Bit. Material = 4,400 \text{ sq. yd.} \times \frac{0.30 \text{ gal.}}{\text{sq. yd.}} = \underline{\underline{1,320 \text{ gal.}}}$$

$$\#8 \text{ stone} = 4,400 \text{ sq. yd.} \times \frac{0.00083 \text{ cu. yd.}}{\text{sq. yd.}} = \underline{\underline{3.65 \text{ cu. yd.}}}$$

$$Weight = 3.65 \text{ cu. yd.} \times \frac{3,800 \text{ lbs.}}{\text{cu. yd.}} = 13,877.6 \text{ lbs.}$$

$$\frac{13,877.6 \text{ lbs.}}{2,000 \text{ lbs.} / \text{ton}} = \underline{\underline{6.94 \text{ ton}}}$$

AREA OF AN INTERSECTION

40. What is the total surface area of the intersection 100 ft. each way from the center? The east-west road is 24 ft. wide and the north-south road is 20 ft. wide.

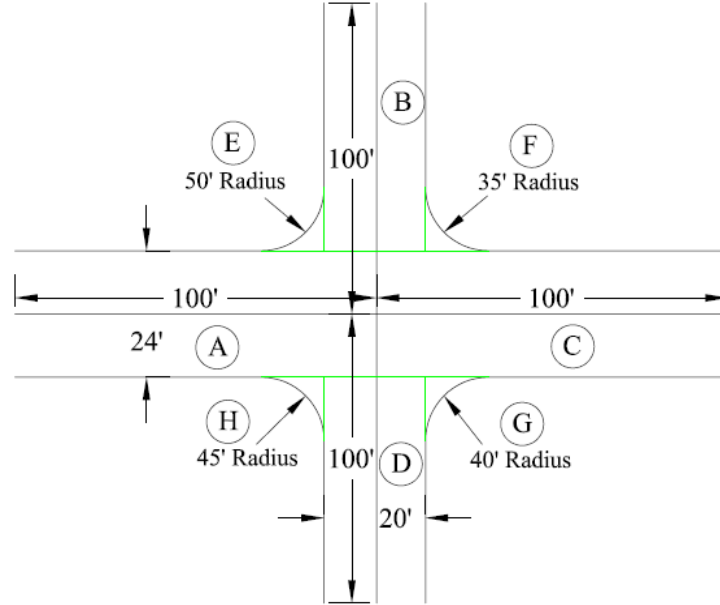

Rule 1

$$Area_A = 100 \text{ ft.} \times 24 \text{ ft.} = 2,400 \text{ sq. ft.}$$

$$Area_B = (100 \text{ ft.} - 12 \text{ ft.}) \times 20 \text{ ft.} = 1,760 \text{ sq. ft.}$$

$$Area_C = 100 \text{ ft.} \times 24 \text{ ft.} = 2,400 \text{ sq. ft.}$$

$$Area_D = (100 \text{ ft.} - 12 \text{ ft.}) \times 20 \text{ ft.} = 1,760 \text{ sq. ft.}$$

Rule 1  
Rule 5

$$Area_E = (50 \text{ ft.} \times 50 \text{ ft.}) - \frac{1}{4} (3.14 \times 50 \text{ ft.} \times 50 \text{ ft.}) = 537.50 \text{ sq. ft.}$$

$$Area_F = (35 \text{ ft.} \times 35 \text{ ft.}) - \frac{1}{4} (3.14 \times 35 \text{ ft.} \times 35 \text{ ft.}) = 263.38 \text{ sq. ft.}$$

$$Area_G = (40 \text{ ft.} \times 40 \text{ ft.}) - \frac{1}{4} (3.14 \times 40 \text{ ft.} \times 40 \text{ ft.}) = 344.00 \text{ sq. ft.}$$

$$Area_H = (45 \text{ ft.} \times 45 \text{ ft.}) - \frac{1}{4} (3.14 \times 45 \text{ ft.} \times 45 \text{ ft.}) = 435.38 \text{ sq. ft.}$$

$$\underline{\underline{Total = 9,900.26 \text{ sq. ft.}}}$$

LIQUID CALCIUM CHLORIDE

41. Calcium chloride is stored in a tank to pre-wet truck loads of salt and/or grits. The net weight of material has to be converted to gallons for ODOT bookkeeping purposes. This is illustrated in solving the following problem:

Five trucks hauling 8-tons of material each haul two loads during a storm. All the trucks were treated with a calcium chloride solution at the rate of 8 gallons per ton.

If a 49,000 lb.-truck load of 30% solution @ 70° F was stored in the tank, how many gallons of solution are left after treating these truck loads of material? (Check rule 16 for Specific Gravity and Unit Weight of a gallon of solution)

$$5 \text{ trucks} \times \frac{2 \text{ loads}}{\text{truck}} = 10 \text{ loads}$$

$$10 \text{ loads} \times \frac{8 \text{ ton}}{\text{load}} = 80 \text{ ton}$$

$$80 \text{ ton} \times \frac{8 \text{ gal.}}{\text{ton}} = 640 \text{ gal.}$$

Rule 16

$$30\% \text{ Solution @ } 70^\circ F \Rightarrow \text{Specific Gravity} = 1.295 + 7(0.0003) = \underline{\underline{1.297}}$$

$$30\% \text{ Solution @ } 70^\circ F \text{ weighs } 1.297 \times 8.33 = 10.80 \frac{\text{lbs.}}{\text{gal.}}$$

$$\text{Gal. in truck} = \frac{49,000 \text{ lbs.}}{10.80 \frac{\text{lbs.}}{\text{gal.}}} = 4,537.04 \text{ gal.}$$

$$\# \text{ gal. remaining} = 4,537.04 \text{ gal.} - 640 \text{ gal.} = \underline{\underline{3,897.04 \text{ gal.}}}$$

LIQUID CALCIUM CHLORIDE

42. Stockpiles of salt may be pre-wetted by injection with a 42% solution of calcium chloride. This material is delivered at 80° F. Lets work the same problem we just completed for the following two conditions:

1. Salt only
2. 50/50 mixture of salt and sand

Assume a 1,000 ton pile of salt has been treated with 48,000 lbs. of 42% solution at 80° F. Five trucks hauling 8 tons each make 2 trips. How many gallons should be deducted for each set of conditions? How many gallons are remaining in the stockpile?

Rule 16

$$42\% \text{ Solution @ } 80^{\circ}F \Rightarrow \text{Specific Gravity} = 1.438 - 3(0.0003)$$

$$= 1.437$$

$$\text{Weight} = 1.437 \times 8.33 \frac{\text{lbs.}}{\text{gal.}} = 11.97 \frac{\text{lbs.}}{\text{gal.}}$$

$$\frac{48,000 \text{ lbs.}}{11.97 \frac{\text{lbs.}}{\text{gal.}}} = 4,010.03 \text{ gal. of } 42\% \text{ solution used}$$

$$\text{and, } \frac{4,010.03 \text{ gal.}}{1,000 \text{ ton}} = 4.010 \text{ gal./ton}$$

$$5 \text{ trucks} \times 2 \frac{\text{loads}}{\text{truck}} \times 8 \frac{\text{tons}}{\text{load}} = 80 \text{ tons}$$

$$1. \text{ Salt only} - 80 \text{ ton} \times 4.01 \frac{\text{gal.}}{\text{ton}} = 320.80 \text{ gal.}$$

$$4,010.03 \text{ gal.} - 320.80 \text{ gal.} = \underline{\underline{3,689.23 \text{ gal.}}}$$

$$2. \text{ 50/50 mix} - \frac{80}{2} = 40 \text{ ton} \times 4.01 \frac{\text{gal.}}{\text{ton}} = 160.40 \text{ gal.}$$

$$4,010.03 \text{ gal.} - 160.40 \text{ gal.} = \underline{\underline{3,849.6 \text{ gal.}}}$$

**ASPHALT PATCHES**

43. There are four bad areas between MP 4.15 and MP 6.00. Pavement is 22-ft. wide. Two of these patches are one-half width, 550 and 480 ft. long. Use 1-in. of 404 and tack the areas with 0.075 gal./sq. yd. with RS-2. How many tons of 404 asphalt (use 4,000 lbs./cu. yd.) and gallons of RS-2 will be needed? You will also need to calculate how many tons of berm stone it will take to do both sides of each full-width patch and one side of the half-width patches. Use 2-in. thick and 2-ft. wide for berm work. (Use 3,800 lbs. per cu. yd.)

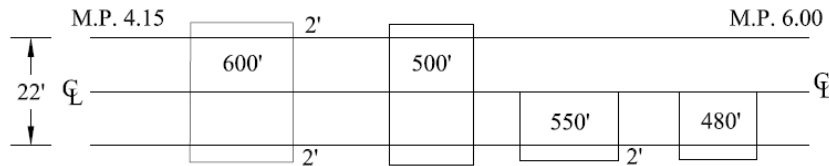

Rule 3

Asphalt

$$500 \text{ ft.} \times 22 \text{ ft.} = 11,000 \text{ sq. ft.}$$

$$600 \text{ ft.} \times 22 \text{ ft.} = 13,200 \text{ sq. ft.}$$

$$550 \text{ ft.} \times 11 \text{ ft.} = 6,050 \text{ sq. ft.}$$

$$480 \text{ ft.} \times 11 \text{ ft.} = 5,280 \text{ sq. ft.}$$

Berm Agg.

$$2 \times 500 \text{ ft.} = 1,000 \text{ ft.}$$

$$2 \times 600 \text{ ft.} = 1,200 \text{ ft.}$$

$$1 \times 550 \text{ ft.} = 550 \text{ ft.}$$

$$1 \times 480 \text{ ft.} = 480 \text{ ft.}$$

Table 7

$$\text{Sum} = \frac{35,530 \text{ sq. ft.}}{9 \frac{\text{sq. ft.}}{\text{sq. yd.}}} = 3,947.8 \text{ sq. yd.} \quad \text{Sum} = 3,230 \text{ ft.}$$

Rule 6  
Table 4

Asphalt

$$35,530 \text{ sq. ft.} \times \frac{1 \text{ in.}}{12 \frac{\text{in.}}{\text{ft.}}} \times \frac{1}{27 \frac{\text{cu. ft.}}{\text{cu. yd.}}} \times \frac{2 \text{ ton}}{\text{cu. yd.}} = \underline{\underline{219.3 \text{ ton}}}$$

Tack

$$3,947.9 \text{ sq. yd.} \times \frac{0.075 \text{ gal.}}{\text{sq. yd.}} = \underline{\underline{296.09 \text{ gal.}}}$$

Rule 6  
Table 4

Berm Agg.

$$3,230 \text{ ft.} \times 2 \text{ ft.} \times \frac{2 \text{ in.}}{12 \frac{\text{in.}}{\text{ft.}}} = \frac{1,076.67 \text{ cu. ft.}}{27 \frac{\text{cu. ft.}}{\text{cu. yd.}}} = 39.88 \text{ cu. yd.}$$

Table 5

$$39.88 \text{ cu. yd.} \times 3,800 \text{ lbs.} \times 1 \text{ ton} = \underline{\underline{75.77 \text{ ton}}}$$

**VOLUME OF STOCKPILE**

44. A stockpile has a height of 6 ft. and a base of 12 ft. The width of the top is 5 ft. and the length of the stockpile is 100 ft. The slope of the ends is the same as the sides. Estimate the number of cubic yards of material in the stockpile.

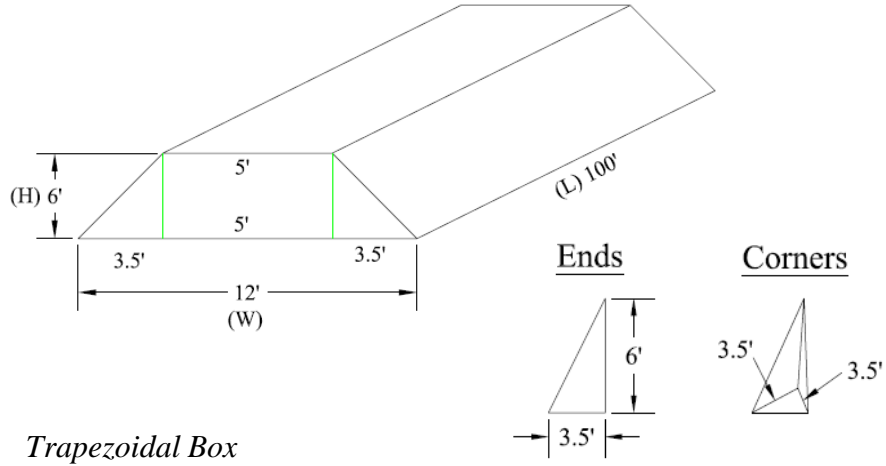

Trapezoidal Box

Rule 8

$$\text{Volume} = \left( \frac{5 \text{ ft.} + 12 \text{ ft.}}{2} \right) \times 6 \text{ ft.} \times 100 \text{ ft.} = \underline{\underline{5,100 \text{ cu. ft.}}}$$

Ends

Rule 7

$$\frac{1}{2} \times 6 \text{ ft.} \times 3.5 \text{ ft.} \times 5 \text{ ft.} = 52.50 \text{ cu. ft.}$$

$$2 \text{ ends} \times 52.50 \text{ cu. ft.} = \underline{\underline{105.00 \text{ cu. ft.}}}$$

Corners

Rule 18

$$\text{End Area} = \frac{1}{2} (3.5 \text{ ft.} \times 3.5 \text{ ft.}) = 6.125 \text{ sq. ft.}$$

$$\text{Volume} = \frac{1}{3} (6.125 \text{ sq. ft.}) \times 6 \text{ ft.} = 12.250 \text{ cu. ft.}$$

$$4 \text{ corners} \times 12.250 \text{ cu. ft.} = \underline{\underline{49.00 \text{ cu. ft.}}}$$

Total

$$\text{Volume} = \frac{5,254.00 \text{ cu. ft.}}{27 \frac{\text{cu. ft.}}{\text{cu. yd.}}} = \underline{\underline{194.59 \text{ cu. yd.}}}$$

Note:

*Figuring the ends and corners doesn't affect the answer much!*

**PERSON – DAYS**

45. One PERSON – DAY is equivalent to eight (8) man – hours of work. How many PERSON – DAYS are represented by the following?

- 2 – men, 8 hours each, for one (1) day
- 1 – man, 3 hours each of two (2) days
- 3 – men, 2 hours each, for (1) day

$$2 \times 8 = 16 \text{ hr.}$$

$$1 \times 3 \times 2 = 6 \text{ hr.}$$

$$3 \times 2 \times 1 = 6 \text{ hr.}$$

$$28 \text{ hr.}$$

$$\frac{28 \text{ hr.}}{8 \text{ hr.} / \text{PERSON-DAYS}} = \underline{\underline{3.5 \text{ PERSON-DAYS}}}$$

**BRIDGE DECK REPAIR**

46. A wooden bridge deck needs replaced. How many pieces of 3"x6"x20' strip floor will be required to replace the deck on a bridge, 20' wide and 30' long? Each strip will be placed on edge which is 2.5" wide.

*Assume no waste*

$$\text{Deck Area} = 20 \text{ ft.} \times 30 \text{ ft.} = 600 \text{ sq. ft.}$$

$$\text{Area per strip} = \frac{2.5 \text{ in.}}{12 \text{ in.} / \text{ft.}} \times 20 \text{ ft.} = 4.17 \text{ sq. ft.} / \text{strip}$$

$$\text{No. of strips} = \frac{600 \text{ sq. ft.}}{4.17 \text{ sq. ft.} / \text{strip}} = 143.9 \quad \underline{\underline{\text{Use 144 strips}}}$$

Rule 1

Table 3



**SALT SHED CAPACITY**

47. What is the capacity, in tons, of the salt shed pictured below?  
Assume salt weighs one (1) ton per cubic yard.

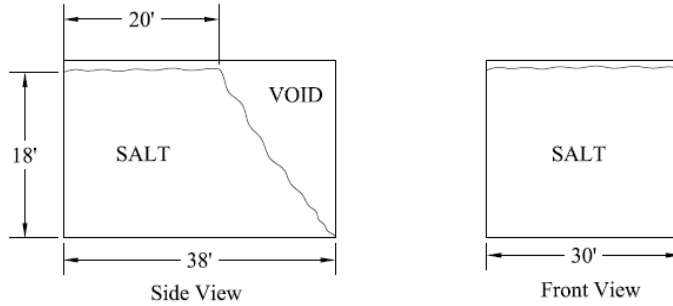

Rule 7

$$Volume = \left( \frac{20 \text{ ft.} + 38 \text{ ft.}}{2} \right) \times \frac{18 \text{ ft.}}{1} \times \frac{30 \text{ ft.}}{1} \times \frac{1}{27} = 580 \text{ cu. yd.}$$

$$Capacity = 580 \text{ cu. yd.} \times \frac{1 \text{ ton}}{\text{cu. yd.}} = \underline{\underline{580 \text{ ton}}}$$

**CULVERT SIZES**

48. Given the following combination of culvert sizes, arrange in order the culvert of combination of culverts with the largest flow capacity to the smallest.

- a. 6 @ 12 in. diameter culverts
- b. 2 @ 24 in. diameter culverts
- c. 3 @ 18 in. diameter culverts
- d. 1 @ 36 in. diameter culverts
- e. 4 @ 15 in. diameter culverts

Rule 5

$$Area_a = \pi \left( \frac{12 \text{ in.}}{2} \right)^2 = 113.10 \text{ sq. in.} \times 6 = 678.6 \text{ sq. in.}$$

$$Area_b = \pi \left( \frac{24 \text{ in.}}{2} \right)^2 = 452.39 \text{ sq. in.} \times 2 = 904.8 \text{ sq. in.}$$

$$Area_c = \pi \left( \frac{18 \text{ in.}}{2} \right)^2 = 254.47 \text{ sq. in.} \times 3 = 763.4 \text{ sq. in.}$$

$$Area_d = \pi \left( \frac{36 \text{ in.}}{2} \right)^2 = 1,017.88 \text{ sq. in.} \times 1 = 1,017.88 \text{ sq. in.}$$

$$Area_e = \pi \left( \frac{15 \text{ in.}}{2} \right)^2 = 176.71 \text{ sq. in.} \times 4 = 706.8 \text{ sq. in.}$$

Answers : d, b, c, e, a

	<b>CRACK SEALER</b>
	<p>49. Convert seven (7) 60 lb. blocks of crack sealer to gallons when one gallon of crack sealer weighs 8.25 lb.</p> <p><i>Total Weight = 7 × 60 lbs. = 420 lbs.</i></p> $\text{No. of gallons} = \frac{420 \text{ lbs.}}{8.25 \text{ lbs./gal.}} = 50.91 \text{ gal.} \quad \underline{\underline{\text{Use 51 gal.}}}$
Table 3	<b>BERM CONDITIONING</b>
	<p>50. Estimate the amount of material needed, in tons, for berm conditioning a 2 mile section of two – lane road. Use an average thickness of 2” and an average width of 3’. Assume a cubic yard of berm aggregate weighs 3,000 lb.</p> $\text{Length} = \frac{5,280 \text{ ft.}}{\text{mi.}} \times 2 \text{ mi.} = 10,560 \text{ ft.}$ $\text{Thickness} = \frac{2 \text{ in.}}{12 \text{ in./ft.}} = 0.16667 \text{ ft.}$ $\frac{5,280 \text{ cu. ft.}}{27 \frac{\text{cu. ft.}}{\text{cu. yd.}}} \times 2 (\text{both sides}) = 391.1 \text{ cu. yd.}$ $391.1 \text{ cu. yd.} \times 3,000 \frac{\text{lbs.}}{\text{cu. yd.}} \times \frac{1 \text{ ton}}{2,000 \text{ lbs.}} = 586.7 \text{ ton} \quad \underline{\underline{\text{Use 587 ton}}}$

MOWING	
Problem #3	<p>51. A highway worker mowed a 12 acre interchange using a 6 ft. mower. How many swath miles should be reported? (43,560 sq. ft. per acre – Table 7)</p> $\text{swath mile} = 5,280 \text{ ft.} \times 5 \text{ ft.} = 26,400 \text{ sq. ft.}$
Table 7	$12 \text{ acre} \times 43,560 \frac{\text{sq. ft.}}{\text{acre}} = 522,720 \text{ sq. ft.}$ $\text{No. swath miles} = \frac{522,720 \text{ sq. ft.}}{26,400 \text{ sq. ft.} / \text{swath mi.}} = \underline{\underline{19.8 \text{ swath mi.}}}$
TANK CAPACITY	
Rule 17	<p>52. If a tank has a diameter of 6 feet and a length of 12 feet, how many gallons of liquid would it hold? Assume one cubic foot = 7.5 gallons.</p> $\text{Tank Volume} = \pi \left( \frac{6 \text{ ft.}}{2} \right)^2 \times 12 \text{ ft.} = 339.29 \text{ cu. ft.}$ $\text{No. of gal.} = 339.29 \text{ cu. ft.} \times \frac{7.5 \text{ gal.}}{\text{cu. ft.}} = 2,544.69 \quad \underline{\underline{\text{Use } 2,545 \text{ gal.}}}$

CONCRETE BATCHING

53. The District Bridge Engineer would like to repair a concrete bridge and estimates that about 1.5 cubic yards of Class S concrete will be needed. Since this is a small job and will take a good bit of time to remove the deteriorated concrete and build forms, etc., it will be necessary to use a portable mixer. Mixer is designed to handle 1 sack batches. What would be the weights of material (cement, sand and limestone) needed for each batch. ODOT gives the following one (1) cubic yard batch:

(One sack = 94 lb. of cement)

Cement -----	715 lb.
Sand -----	1,260 lb.
Limestone -----	1,530 lb.
Water / Cement Ratio -----	0.44

$$\frac{715 \text{ lbs.}}{94 \text{ lbs.} / \text{one-sack batch}} = 7.6 \text{ one-sack batches}$$

$$\text{Cement} = \frac{715 \text{ lbs.}}{7.6 \text{ one-sack batches}} = \underline{\underline{94 \text{ lbs.}}}$$

$$\text{Sand} = \frac{1,260 \text{ lbs.}}{7.6 \text{ one-sack batches}} = \underline{\underline{166 \text{ lbs.}}}$$

$$\text{Limestone} = \frac{1,530 \text{ lbs.}}{7.6 \text{ one-sack batches}} = \underline{\underline{201 \text{ lbs.}}}$$

$$\text{Water} = \frac{0.44 \times 715 \text{ lbs.}}{7.6 \text{ one-sack batches}} = \underline{\underline{41 \text{ lbs.}}}$$

DRAG PATCHING	
	<p>54. You need to drag patch a piece of pavement that is 120' long and 10' wide with an average thickness of 2". How many tons of asphalt will you need? (One cu. yd. of asphalt weighs 2 tons)</p>
Table 3	$\text{Thickness} = \frac{2 \text{ in.}}{12 \text{ in./ft.}} = 0.1667 \text{ ft.}$
Rule 6	$\text{Volume} = 120 \text{ ft.} \times 10 \text{ ft.} \times 0.1667 \text{ ft.} = 200 \text{ cu. ft.}$
Table 4	$\text{No. of cu. yd.} = \frac{200 \text{ cu. ft.}}{27 \frac{\text{cu. ft.}}{\text{cu. yd.}}} = 7.41 \text{ cu. yd.}$
	$\text{No. of tons} = 7.41 \text{ cu. yd.} \times \frac{2 \text{ ton}}{\text{cu. yd.}} = 14.82 \text{ ton} \quad \underline{\underline{\text{Use 15 ton}}}$
CULVERT INSTALLATION	
	<p>55. A 100-ft. long culvert is to be replaced at a one (1) percent grade where the inlet elevation is assumed to be 100.00 ft. What is the required outlet elevation using a lock level and ruler?</p>
Rule 12	$\text{grade} = 1\% = \frac{1}{100} = 0.01$
	$\text{change in elevation} = 0.01 \times 100 \text{ ft.} = 1 \text{ ft.}$
	$\text{outlet elev.} = 100.00 \text{ ft.} - 1.00 \text{ ft.} = \underline{\underline{99.00 \text{ ft.}}}$

**STRAIGHT LINE MILEAGE**

56. You want to calculate a mileage from the SLM book. What is the distance from Bridge No. 4.02 to a sign at SLM 5.00 when there is an equation of 4.25B = 4.05A?

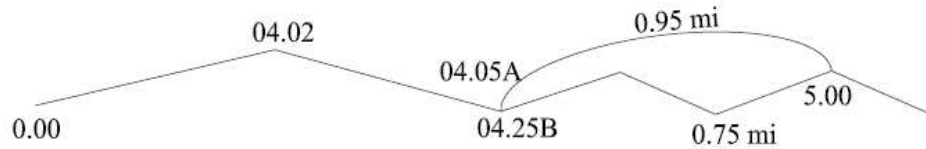

$$0.23mi. + 0.95mi. = \underline{\underline{1.18mi.}}$$

This is done to keep from changing the SLM or Log Point of structures and poles, etc. At a future date, ODOT may re-inventory the road and eliminate the equation.

**EDGE LINE PAINTING**

57. If it takes 16 gallons to paint one mile of 4-inch highway edge line and 6 pounds of reflective beads for each gallon of paint used, how many pounds of beads will be required for 18,480 feet of edge line?

Table 3

$$\text{No. of miles} = \frac{18,480 \text{ ft.}}{5,280 \frac{\text{ft.}}{\text{mi.}}} = 3.5 \text{ mi.}$$

$$\text{No. of gallons} = 3.5 \text{ mi.} \times 16 \frac{\text{gal.}}{\text{mi.}} = 56 \text{ gal.}$$

$$\text{Pounds of beads} = 56 \text{ gal.} \times 6 \frac{\text{lbs.}}{\text{gal.}} = \underline{\underline{336 \text{ lbs.}}}$$

### ASPHALT QUANTITIES

58. You have received three tickets for asphalt placed on a driveway into the county garage. The tickets are for 20,000 lb., 24,000 lb., and 32,000 lb. Since it is a 404 gravel mix, we can assume there are 2 tons in each cubic yard of asphalt. How many cubic yards of material were placed on the driveway?

$$20,000\text{lbs.} + 24,000\text{lbs.} + 32,000\text{lbs.} = 76,000\text{lbs.}$$

$$76,000\text{lbs.} \times \frac{1\text{ton}}{2,000\text{lbs.}} \times \frac{1\text{cu. yd.}}{2\text{ton}} = \underline{\underline{19\text{cu. yd.}}}$$

### LANE CLOSURE

59. You need to close one lane of a 4-lane highway in a rural area. The lane is 12-ft wide and the posted speed limit is 65 mph. Determine the taper length (L) using the formula  $L = WS$  where:

W = Pavement lane width (ft.)

S = Speed (posted) in mph

$$\text{Length} = W \times S = 12\text{ ft.} \times 65\text{ mph} = \underline{\underline{780\text{ ft.}}}$$

### CENTERLINE PAVEMENT MARKINGS

60. Determine the rate of application of double yellow centerline pavement markings to a pavement using the formula rate (R) = Gallons of paint (G) divided by distance of solid line in Miles (M) when 185 gallons of paint have been applied to 4.5 miles of road.

$$R = \frac{G}{M} = \frac{185\text{ gal.}}{4.5\text{ mi.}} = 41.1 \frac{\text{gal.}}{\text{mi.}} \quad \underline{\underline{\text{Use } 41 \frac{\text{gal.}}{\text{mi.}}}}$$

### SHOULDER WIDENING

61. You want to add 2 feet and a 3:1 slope on to a shoulder that is 4 feet to top of ditch and a 2:1 slope now and this needs to be done for 1,000 feet. How many cubic yards of dirt will you need to make this improvement?

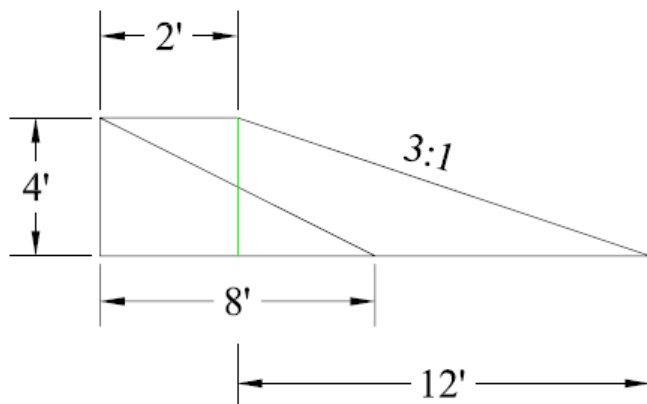

Rule 3

$$\text{Total area} = (2 \text{ ft.} \times 4 \text{ ft.}) + \frac{1}{2}(4 \text{ ft.} \times 12 \text{ ft.}) = 32 \text{ sq. ft.}$$

Rule 4

$$\text{Existing} = \frac{1}{2}(4 \text{ ft.} \times 8 \text{ ft.}) = 16 \text{ sq. ft.}$$

$$\text{Fill} = 32 \text{ sq. ft.} - 16 \text{ sq. ft.} = 16 \text{ sq. ft.}$$

Rule 6

$$\text{Volume} = \frac{16 \text{ sq. ft.} \times 1,000}{27 \frac{\text{cu. ft.}}{\text{cu. yd.}}} = 593 \text{ cu. yd.}$$



STRAIGHT LINE MILEAGE

62. Refer to Figure 1. (pg. 37) and Figure 2. (pg. 38) which is a map of the Cumberland area and a page from the SLM book for GUE-146. Using this information please answer the following questions:

1. What is the SLM for the intersection of the SR 146 and the B&O Railroad?     3.91

2. What is the distance in miles between the Corporation lines on SR 146?     1.13 mi.

3. What is the width of the pavement surface between the Muskingum Co. line and SR 340?     20 ft.

4. What is the SLM for the intersection of SR 83 and SR 146?     1.87

5. What are the SLM limits for Section 0.00?     0.00 to 1.70

6. What determines the SLM for a Section?  
          Beginning SLM or Log Point

7. What is the SLM of the bridge between the East Cumberland Corp. line and the B&O Railroad?     3.44

8. Where do the 0.00 SLM's begin for East-West routes and North-South routes?  
          Western most point   E-W  
          Southern most point   N-S

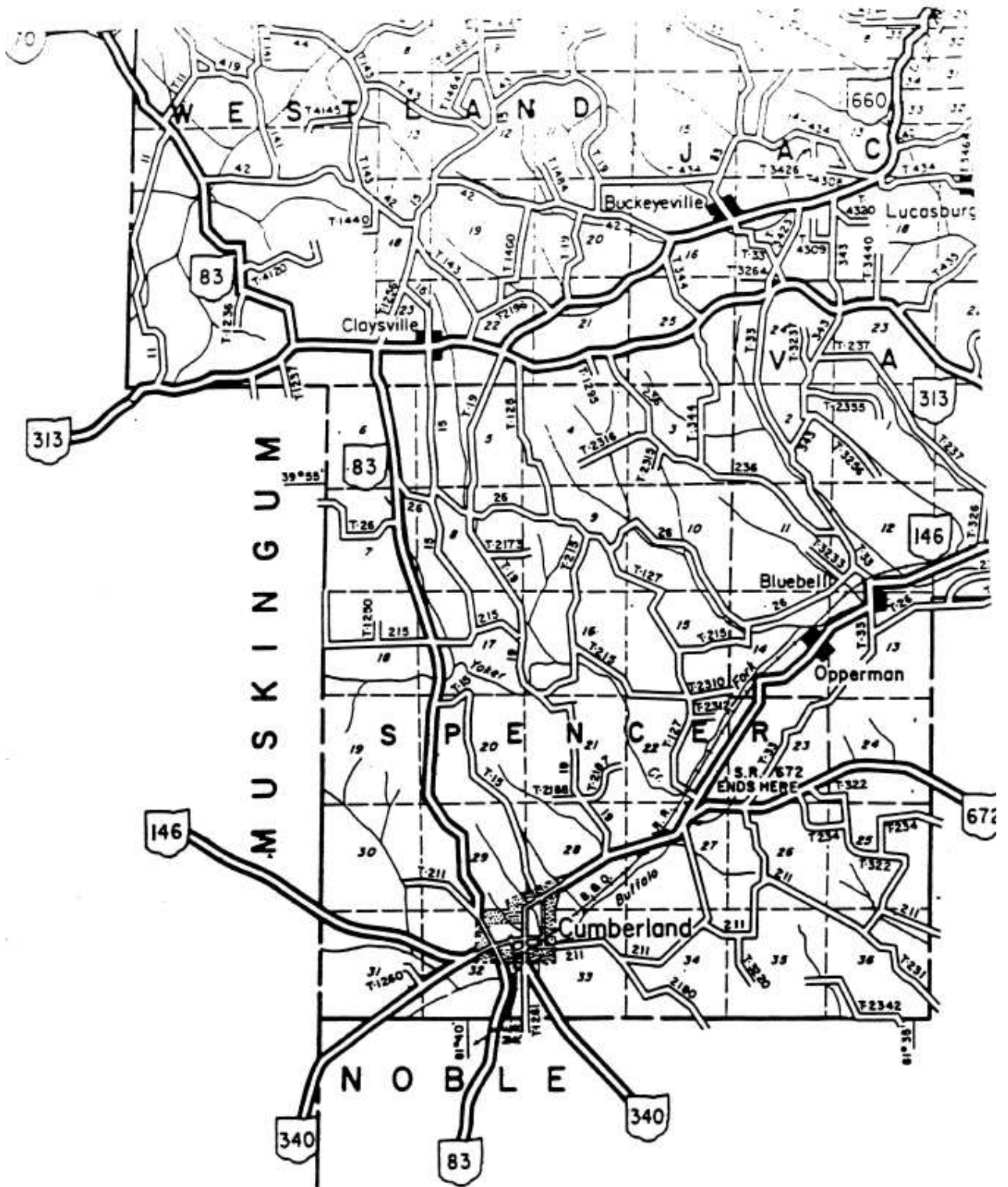

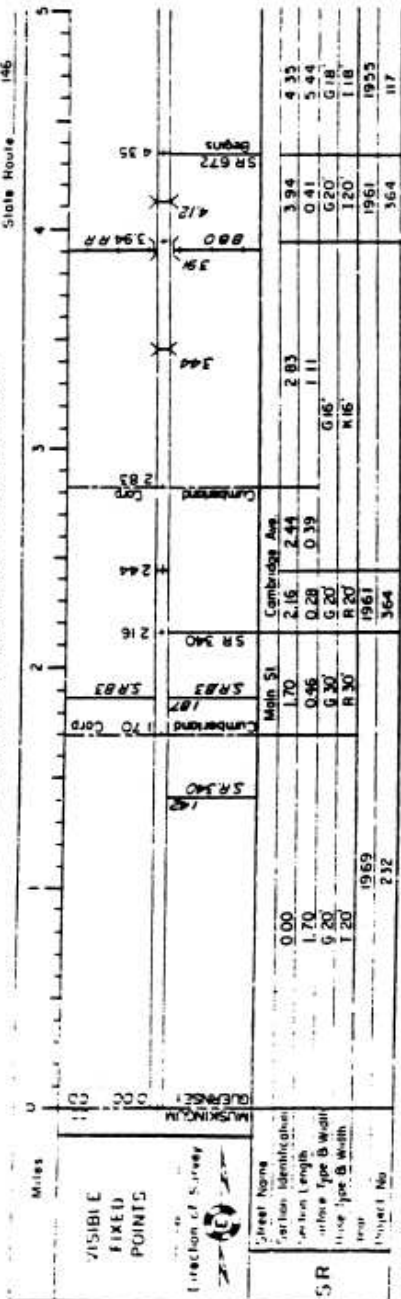

PERPETUATION

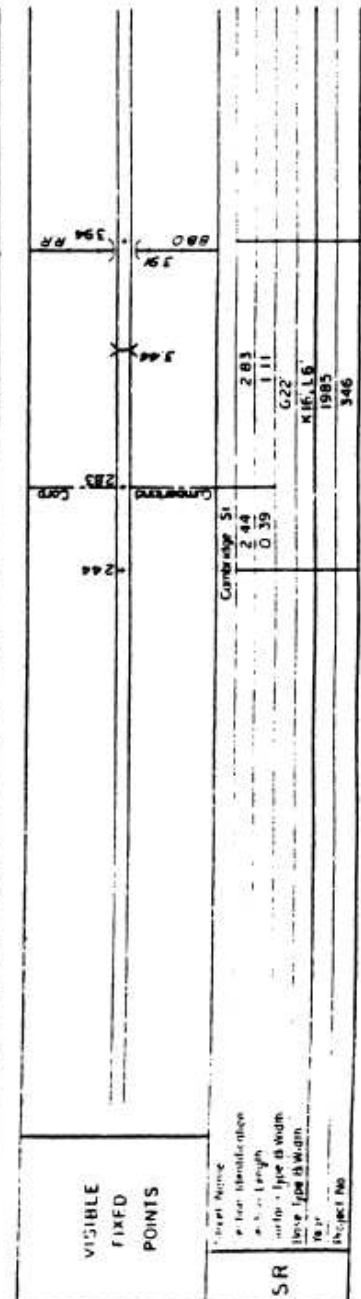
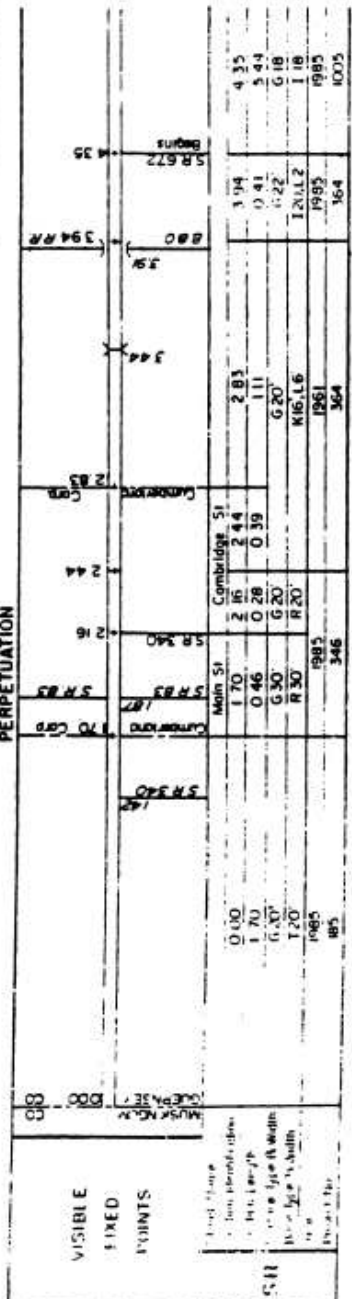

**DUMPED ROCK**

Rule 6

63. Suppose you wanted to know how many tons of dumped rock you would need to fill a volume 800 feet long by 14 feet wide with an average depth of 8 feet. If the material you will use weighs about 3,700 lb a cu. yd., how many tons will be used?

$$Volume = 800 \text{ ft.} \times 14 \text{ ft.} \times 8 \text{ ft.} = \frac{89,600 \text{ cu. ft.}}{27 \frac{\text{cu. ft.}}{\text{cu. yd.}}} = 3,318.5 \text{ cu. yd.}$$

$$Tons = 3,318.5 \text{ cu. yd.} \times 3,700 \frac{\text{lbs.}}{\text{cu. yd.}} \times \frac{1 \text{ ton}}{2,000 \text{ lbs.}} = 6,139.3 \text{ tons}$$

Use 6,139 tons

**PURCHASE ORDER FOR ASPHALT CONCRETE**

64. You have an open Purchase Order for 500 tons of asphalt concrete. If each of your trucks can haul 6 cubic yards, how many loads can you haul to complete the order? (Use conversion of 4,000 lb. a cu. yd.)

$$6 \text{ cu. yd.} / \text{truck} \Rightarrow 6 \text{ cu. yd.} \times \frac{4,000 \text{ lbs.}}{\text{cu. yd.}} \times \frac{1 \text{ ton}}{2,000 \text{ lbs.}} = 12 \text{ ton} / \text{truck}$$

$$No. \text{ of trucks} = \frac{500 \text{ tons}}{12 \frac{\text{tons}}{\text{truck}}} = 41.67 \text{ loads}$$

Use 42 loads

## APPENDIX A

The six most common types of measures used to estimate quantities for road work are:

- Length
- Area
- Space Volume (containers)
- Liquid Volume
- Weight
- Rate (as in gallons per square yard)

The TABLES and RULES are presented to help with the calculation of surface areas and volumes of containers or material that have three dimensions – length, breadth, and thickness. Terms such as width, height, depth, and base are also used.

**Table of Contents**  
 APPENDIX (Pages A-1 through A-21)

	Page A-
Abbreviations .....	1
Acres .....	1, 2
Add .....	1
Area .....	2, 3, 4, 5, 6, 7, 8, 9, 11
Asphalt .....	9
Average .....	1, 9
Calcium .....	10
Capacity .....	12
Center .....	5
Chloride .....	10
Circle .....	5
Circumference .....	1, 5
Cone .....	6, 8
Cylinder .....	6, 11
Decimals .....	2
Deicers .....	9
Depth .....	12
Diameter .....	1, 5
Distance .....	5, 9
Divide .....	1
Factor, Conversion .....	12
Foot .....	2, 9
Gallons .....	1, 2, 9, 10, 12
Grade .....	9
Grams .....	1
Grits .....	9
Height .....	1, 3, 4, 6, 7, 8, 11
Hundredth .....	2
Inches .....	1
Kilogram .....	2

**Table of Contents**  
APPENDIX (Continued)

	Page A-
Lb .....	1, 2, 9, 10
Length .....	1, 2, 3, 6, 7, 11
Level .....	12
Liquid .....	2, 9, 10, 12
Log .....	1
LP, log point.....	1
Maintenance .....	6
Measures .....	2
Mile .....	1, 2, 15
MP, mile post.....	1
Multiply.....	1
Numbers .....	2
Ounces, oz.....	1, 2
Parallelogram .....	3, 4
Percent.....	1, 9
Pi .....	1
Pound .....	2
Pyramid.....	11
Radius .....	1, 5
Rate .....	1, 9
Ratio.....	1, 9
Rectangle.....	3, 4
Rectangular .....	6
Rise .....	9
Salt .....	9
Shapes .....	8
SLM, straight line mile .....	1
Slope .....	9
Solution.....	10
Square .....	1, 2, 3, 4, 9
Squared .....	5
Subtract .....	1, 10
Sum .....	4

**Table of Contents**  
APPENDIX (Continued)

	Page A-
Tables .....	1, 2, 13-20
Tank .....	11, 12
Temperatures.....	10
Ten-Thousandth .....	2
Tenth .....	2
Terms .....	12
Thousandth.....	2
Ton .....	1, 2, 9
Trapezoid .....	4
Trapezoidal .....	7
Triangle.....	4
Triangular.....	7
Vertical.....	9
Volume.....	2, 6, 7, 8, 11
Weight, wt.....	2, 10
Width.....	1, 3, 6, 7
Yard, yd.....	1, 2, 9



**Table 1**

<b>Abbreviations</b>			
Add	+	Circumference	C
Subtract	-	Diameter	D
Multiply	×	Pi ( $\pi$ )	3.14
Divide	÷ /	Radius	R
Ratio or Rate	/ -	Length	L
Equal	=	Height	H
Percent	%	Width	W
Average	Avg.	Base, large	B
Approximate	≈	Base, small	b

**Table 2**

<b>Abbreviations</b>			
Inches	in. or "	Square Inches	sq. in.
Feet	ft. or '	Square Feet	sq. ft. or S.F.
Yards	yd.	Square Yards	sq. yd. or S.Y.
Miles	mi.	Acres	Ac.
Grams	gm.	Cubic Inches	cu. in.
Ounces	oz.	Cubic Feet	cu. ft. or C.F.
Pounds	lbs.	Cubic Yards	cu. yd. or C.Y.
Tons	Ton	Straight Line Mile	SLM
Gallons	gal.	Mile Post	MP
Hours	hr.	Log Point	LP

**Table 3**

Length Measures			Volume Measures	
<u>Foot</u>	<u>Yard</u>	<u>Mile</u>	<u>Cubic Foot</u>	<u>Cubic Yard</u>
12 in	36 in	5280 ft	1728 cu. in.	27 cu. ft.
	3 ft	1760 yds		

**Table 4****Table 5**

Weight Measures			Liquid Measures	
<u>Kilogram</u>	<u>Pound</u>	<u>Ton</u>	<u>Cubic Foot</u>	<u>Gallon</u>
1000 gms	16 oz	2000 lbs	7.5 gals	0.1337 cu. ft.

**Table 6****Table 7**

Area Measures		
<u>Square Foot</u>	<u>Square Yard</u>	<u>Acre</u>
144 sq in	9 sq ft	43,560 sq ft

**Table 8**

Decimals		
<u>Places</u>	<u>Numbers</u>	<u>Expression</u>
one	0.1	Tenth
two	0.01	Hundredth
three	0.001	Thousandth
four	0.0001	Ten-Thousandth

AREAS OF SURFACES

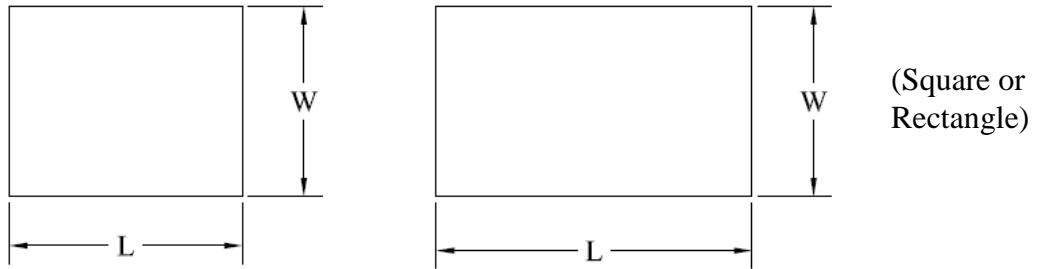

Rule 1: The area (A) of a square or rectangle is calculated by multiplying the length (L) by the width (W).  $A = L \times W$

\* \* \* \* \*

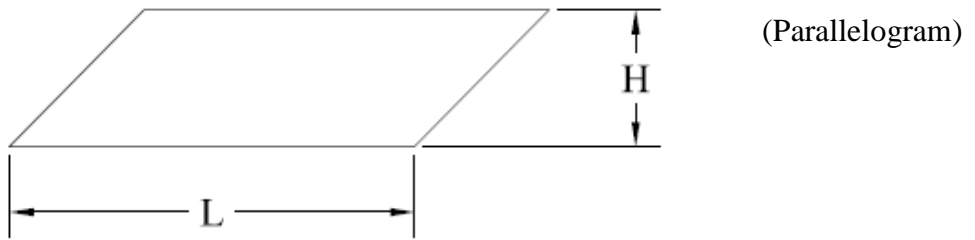

Rule 2: The area (A) of a parallelogram is calculated by multiplying the length (L) times the height (H).  $A = L \times H$

## AREAS

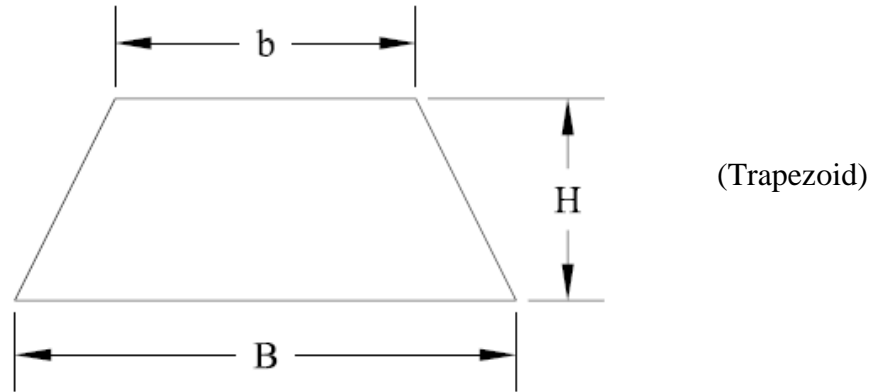

Rule 3: The area (A) of a trapezoid is calculated by multiplying the height (H) times one-half the sum of the bases.  $A = H \times \frac{1}{2} (B + b)$

\* \* \* \* \*

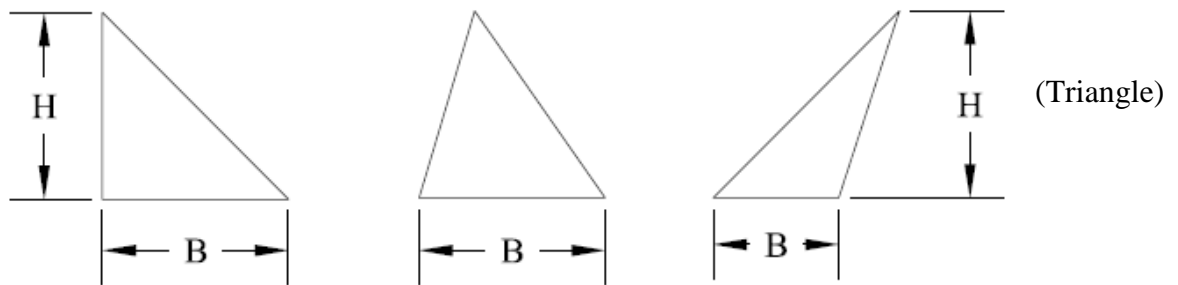

Rule 4: The area (A) of a triangle is calculated by multiplying the base (B) times the height (H) and dividing the answer by 2.  $A = \frac{1}{2} (B \times H)$

(Triangles are  $\frac{1}{2}$  a square, rectangle, or parallelogram.)

## AREAS

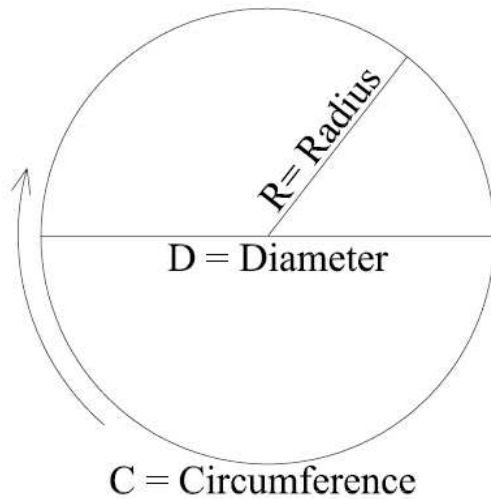

(Circle)

- Circumference is the distance around a circle
- Diameter is a straight line through the center of a circle
- Radius equals half the diameter
- Circumference =  $3.14 \times \text{Diameter}$  or  $3.14 \times 2 \times R$

Rule 5: The area (A) of a circle is calculated by multiplying 3.14 times the radius (R) times the radius (R).  $A = 3.14 \times R \times R$  also written as  $A = 3.14R^2$  (R squared)

## VOLUMES

There are many shapes, the most common of which are boxes, cylinders, and cones. Rules for calculating the volumes or contents that are most used for highway maintenance and repair work are as follows:

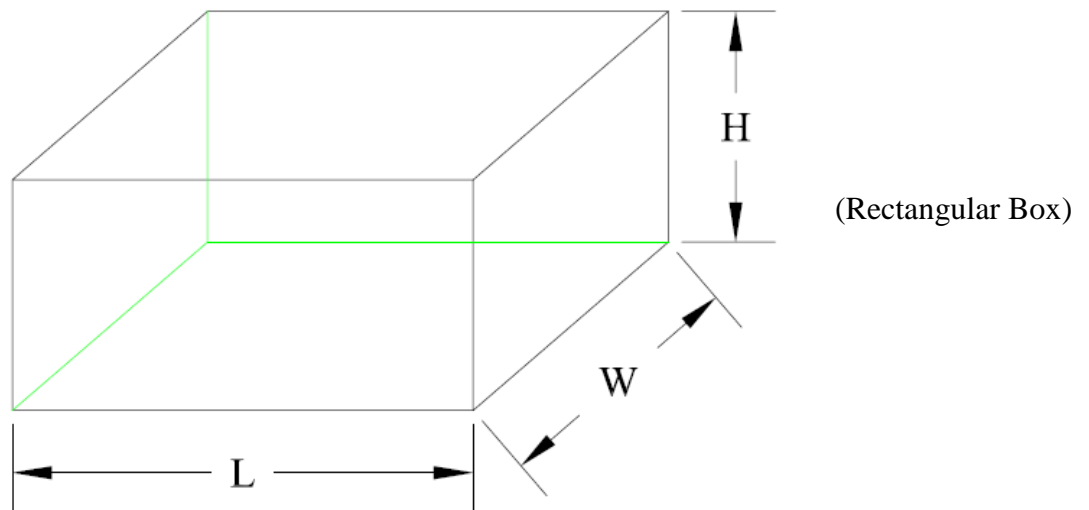

Rule 6: The volume (V) of a rectangular box is calculated by multiplying the length (L) times the width (W) times the height (H).  $V = L \times W \times H$ .  
Using Rule 1 we could say the volume can be obtained by multiplying the area (L x W) x height (H).

## VOLUMES

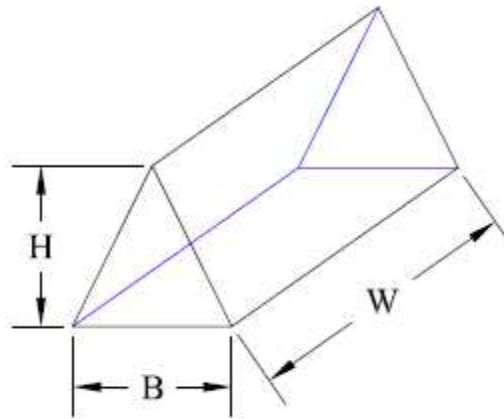

(Triangular Box)

Rule 7: The volume (V) of a triangular box is calculated by multiplying the base (B) times the width (W) and the height (H) and dividing this answer by 2.  
 $V = \frac{1}{2} (B \times W \times H)$

\* \* \* \* \*

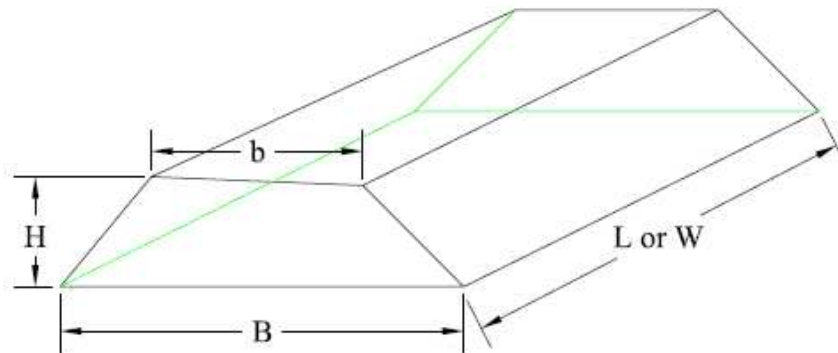

(Trapezoidal Box)

Rule 8: The volume (V) of a trapezoidal box is calculated by multiplying the area (A) of the trapezoidal side by the length (L) or width (W).  
 $V = \frac{1}{2} (B + b) \times H \times L$

## VOLUMES

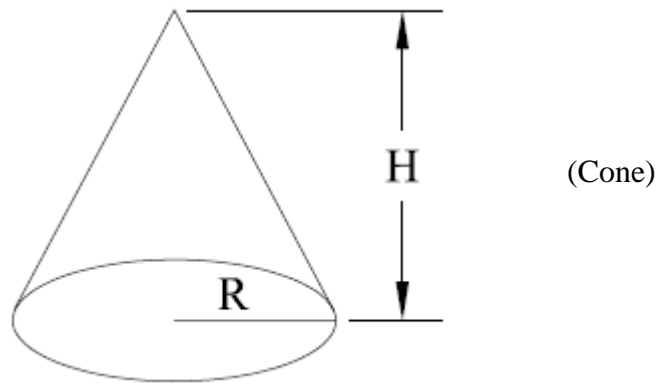

Rule 9: The volume (V) of a cone is calculated by multiplying the area (A) of the base by the height of the cone and dividing by 3.

$$V = 3.14 \times \frac{1}{3} (R \times R) \times H \quad \text{or}$$

$$V = 3.14 \times \frac{1}{3} (R^2) \times H$$



$$\text{Rule 10: Average} = \frac{\text{Total of items added}}{\text{Number of items}}$$

$$\text{Rule 11: Slope ratio} = \frac{\text{Horizontal distance}}{\text{Vertical rise or fall}}$$

Slope ratios are expressed as 3:1, 4:1, etc., meaning 3 ft to 1 ft, 4 ft to 1 ft. The first number is the horizontal distance and the second number is the vertical distance.

$$\text{Rule 12: Percent grade} = \frac{\text{Vertical rise or fall}}{\text{Horizontal distance}} \times 100$$

$$\text{Rule 13: Liquid asphalt application rate (in gallons per square yard)} \\ = \frac{\text{Number of gallons used}}{\text{Area covered in square yards}}$$

$$\text{Rule 14: Area covered by liquid asphalt in square yards} \\ = \frac{\text{Number of gallons used}}{\text{Liquid asphalt application rate (gal./sq.yd.)}}$$

$$\text{Rule 15: Area covered by deicers in square yards} \\ = \frac{\text{Tons of salt} \times 2,000}{\text{Salt/sand application rate (lbs./2 - lane mi)}}$$

Rule 16: Liquid Calcium Chloride					
% Calcium Chloride Solution	Specific Gravity @ 77° F	WT lbs per Gal	% Calcium Chloride Solution	Specific Gravity @ 77° F	WT lbs per Gal
30 (29.5-30.5)	1.295 1.291-1.301	10.76	37 (35.6-37.4)	1.379 1.374-1.384	11.46
31 (30.6-31.4)	1.306 1.302-1.312	10.85	38 (37.5-38.5)	1.391 1.385-1.397	11.56
32 (31.5-32.5)	1.318 1.313-1.325	10.95	39 (38.6-39.4)	1.403 1.398-1.408	11.66
33 (32.6-33.4)	1.331 1.326-1.336	11.06	40 (39.5-40.5)	1.415 1.409-1.421	11.76
34 (33.5-34.5)	1.342 1.337-1.349	11.15	41 (40.6-41.4)	1.426 1.422-1.431	11.85
35 (34.6-35.4)	1.355 1.350-1.360	11.26	42 (41.5-42.5)	1.438 1.432-1.444	11.95
36 (35.5-36.5)	1.366 1.361-1.373	11.35			

NOTE: For temperatures above 77° F, subtract 0.0003 specific gravity units per degree F.

Weight = Specific Gravity x 8.33 lbs

VOLUMES

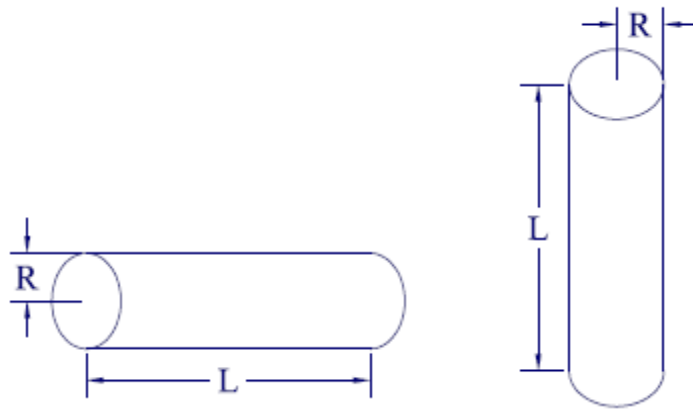

Rule 17: The volume (V) of a cylinder or tank is calculated by multiplying the area (A) of the base or end by the height (H) or length (L) of the object.  
 $V = 3.14 \times R \times R \times L$

\* \* \* \* \*

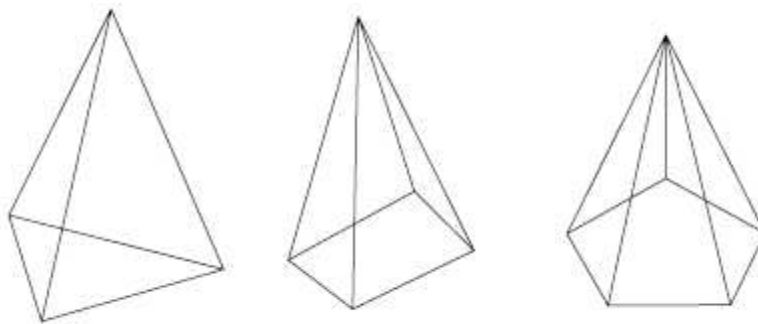

Rule 18: The volume of a pyramid is one-third its base area times its altitude.

Rule 19: Estimating the number of gallons in a tank.  
 Gallons = Conversion Factor x Tank Capacity

Liquid Depth	Conversion Factor
0.16D	0.10
0.21D	0.15
0.25D	0.20
0.30D	0.25
0.34D	0.30
0.38D	0.35
0.42D	0.40
0.46D	0.45
0.50D	0.50
0.54D	0.55
0.58D	0.60
0.62D	0.65
0.66D	0.70
0.70D	0.75
0.75D	0.80
0.79D	0.85
0.84D	0.90
0.90D	0.95

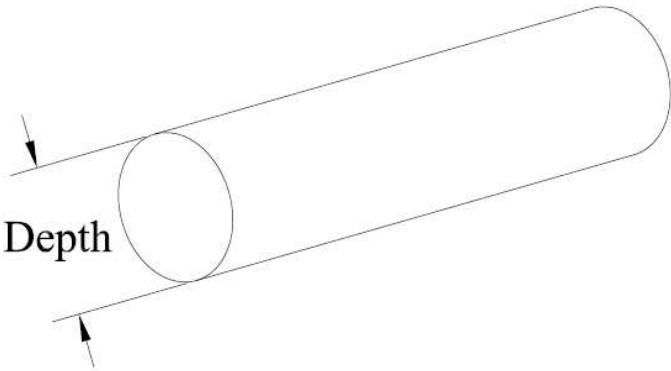

$$\text{LIQUID DEPTH} = \frac{\text{DEPTH FROM BOTTOM}}{\text{DEPTH OF TANK}}$$

Example: Capacity of the tank is 1,000 gallons. Depth is 4 ft. Level of liquid in the tank is 2 ft 3 in from the bottom of the tank. How many gallons are left in the tank?

Answer: Liquid depth is in terms of "D" = 2.25 ft / 4 ft or 0.56D. Since we are estimating the gallons, we can use this chart two ways:

- (1) 0.56D is between 0.54D and 0.58D so we use a Conversion Factor of 0.575. Gallons left in the tank = 0.575 x 1,000 or 575 gallons.
- (2) Or, you could go to the nearest factor in the chart (0.60) and estimate that there are 0.60 x 1,000 or 600 gallons. If you chose to go to the lower factor of 0.55 you would get 0.55 x 1,000 or 550 gallons.

The exact answer is 576 gallons. So, you can make a good estimate by using this chart.

**Table 9**

<b>LINEAL FEET COVERED BY 1000 GALLON TANK</b>								
<b>Road Width (ft)</b>	<b>Gallons Per Square Yard</b>							
	<b>0.60</b>	<b>0.70</b>	<b>0.80</b>	<b>0.90</b>	<b>1.00</b>	<b>1.25</b>	<b>1.50</b>	<b>2.00</b>
8'	1,875	1,607	1,406	1,250	1,125	900	750	563
9'	1,667	1,429	1,250	1,111	1,000	800	667	500
10'	1,500	1,286	1,125	1,000	900	720	600	450
11'	1,364	1,169	1,023	909	818	655	545	409
12'	1,250	1,071	938	833	750	600	500	375
14'	1,071	918	804	714	643	514	429	321
15'	1,000	857	750	667	600	480	400	300
16'	938	804	703	625	563	450	375	281
18'	833	714	625	556	500	400	333	250
20'	750	643	563	500	450	360	300	225
22'	682	584	511	455	409	327	273	205
24'	625	536	469	417	375	300	250	188
25'	600	514	450	400	360	288	240	180
26'	577	495	433	385	346	277	231	173
28'	536	459	402	357	321	257	214	161
30'	500	429	375	333	300	240	200	150

Table 10

<b>LINEAL FEET COVERED BY 1000 GALLON TANK</b>									
<b>Road Width (ft)</b>	<b>Gallons Per Square Yard</b>								
	<b>0.10</b>	<b>0.15</b>	<b>0.20</b>	<b>0.25</b>	<b>0.30</b>	<b>0.33</b>	<b>0.35</b>	<b>0.40</b>	<b>0.50</b>
8'	11,250	7,500	5,625	4,500	3,750	3,375	3,214	2,813	2,250
9'	10,000	6,667	5,000	4,000	3,333	3,000	2,857	2,500	2,000
10'	9,000	6,000	4,500	3,600	3,000	2,700	2,571	2,250	1,800
11'	8,182	5,455	4,091	3,273	2,727	2,455	2,338	2,045	1,636
12'	7,500	5,000	3,750	3,000	2,500	2,250	2,143	1,875	1,500
14'	6,429	4,286	3,214	2,571	2,143	1,929	1,837	1,607	1,286
15'	6,000	4,000	3,000	2,400	2,000	1,800	1,714	1,500	1,200
16'	5,625	3,750	2,813	2,250	1,875	1,688	1,607	1,406	1,125
18'	5,000	3,333	2,500	2,000	1,667	1,500	1,429	1,250	1,000
20'	4,500	3,000	2,250	1,800	1,500	1,350	1,286	1,125	900
22'	4,091	2,727	2,045	1,636	1,364	1,227	1,169	1,023	818
24'	3,750	2,500	1,875	1,500	1,250	1,125	1,071	938	750
25'	3,600	2,400	1,800	1,400	1,200	1,080	1,039	900	720
26'	3,462	2,308	1,731	1,385	1,154	1,038	989	865	692
28'	3,214	2,143	1,607	1,286	1,071	964	918	804	643
30'	3,000	2,000	1,500	1,200	1,000	900	857	750	600

**Table 11**

<b>SQUARE YARDS OF ROAD SURFACE FOR VARIOUS ROAD WIDTHS</b>			
<b>Road Width</b>	<b>Square Yards of Road Surface</b>		
	<b>Per Linear Foot</b>	<b>Per 100 Feet</b>	<b>Per Mile</b>
6'	0.67	66.67	3,520
7'	0.78	77.78	4,107
8'	0.89	88.89	4,693
9'	1.00	100.00	5,280
10'	1.11	111.11	5,867
11'	1.22	122.22	6,453
12'	1.33	133.33	7,040
13'	1.44	144.44	7,627
14'	1.56	155.56	8,213
15'	1.67	166.67	8,800
16'	1.78	177.78	9,387
17'	1.89	188.89	9,973
18'	2.00	200.00	10,560
20'	2.22	222.22	11,733
22'	2.44	244.44	12,907
24'	2.67	266.67	14,080
25'	2.78	277.78	14,667
26'	2.89	288.89	15,253
28'	3.11	311.11	16,427
30'	3.33	333.33	17,600
32'	3.56	355.56	18,773
34'	3.78	377.78	19,947
36'	4.00	400.00	21,120
38'	4.22	422.22	22,293
40'	4.44	444.44	23,467
50'	5.56	555.56	29,333
60'	6.67	666.67	35,200
70'	7.78	777.78	41,067
75'	8.33	833.33	44,000
80'	8.89	888.89	46,933

Table 12

NUMBER OF GALLONS IN A 1000 GALLON TANK (BASED ON PERCENT OF CAPACITY)						
Percent of Depth	Percent of Capacity	Gallons		Percent of Depth	Percent of Capacity	Gallons
1	0.2	2		26	20.7	207
2	0.5	5		27	21.9	219
3	0.9	9		28	23.0	230
4	1.3	13		29	24.1	241
5	1.9	19		30	25.3	253
6	2.5	25		31	26.5	265
7	3.1	31		32	27.7	277
8	3.7	37		33	28.8	288
9	4.5	45		34	30.0	300
10	5.2	52		35	31.2	312
11	6.0	60		36	32.4	324
12	6.8	68		37	33.7	337
13	7.6	76		38	34.9	349
14	8.5	85		39	36.1	361
15	9.4	94		40	37.4	374
16	10.3	103		41	38.6	386
17	11.3	113		42	39.9	399
18	12.2	122		43	41.1	411
19	13.2	132		44	42.4	424
20	14.2	142		45	43.7	437
21	15.3	153		46	44.9	449
22	16.3	163		47	46.2	462
23	17.4	174		48	47.5	475
24	18.5	185		49	48.7	487
25	19.6	196		50	50.0	500



Table 13

POUNDS OF AGGREGATE REQUIRED PER SQ.YD. FOR VARIOUS CUBIC YARD WEIGHTS												
Pounds of Aggregate Per	Pounds of Compacted Aggregate Per Square Yard for Various Depths in Inches											
	1"	2"	3"	4"	5"	6"	7"	8"	9"	10"	11"	12"
1800	50	100	150	200	250	300	350	400	450	500	550	600
1900	53	106	158	211	264	317	369	422	475	528	581	633
2000	56	111	167	222	278	333	389	444	500	556	611	667
2100	58	117	175	233	292	350	408	467	525	583	642	700
2200	61	122	183	244	306	367	428	489	550	611	672	733
2300	64	128	192	256	319	383	447	511	575	639	703	767
2400	67	133	200	267	333	400	467	533	600	667	733	800
2500	69	139	208	278	347	417	486	556	625	694	761	833
2600	72	144	217	289	361	433	506	578	650	722	791	867
2700	75	150	225	300	375	450	525	600	675	750	825	900
2800	78	156	233	311	389	467	544	622	700	778	856	933
2900	81	161	242	322	403	483	564	644	725	806	886	967
3000	83	167	250	333	417	500	583	667	750	833	917	1000
3100	86	172	258	344	431	517	603	689	775	861	947	1033
3200	89	178	267	356	444	533	622	711	800	889	978	1067
3300	92	183	275	367	458	550	642	733	825	917	1008	1100
3400	94	189	283	378	472	567	661	756	850	944	1039	1133
3500	97	194	292	389	486	583	681	778	875	972	1069	1167
3600	100	200	300	400	500	600	700	800	900	1000	1100	1200

**Table 14**

<b>GALLONS OF ASPHALT REQUIRED PER MILE FOR VARIOUS RATES OF APPLICATION</b>																	
<b>Road Width</b>	<b>Gallons Per Square Yard</b>																
	<b>0.10</b>	<b>0.15</b>	<b>0.20</b>	<b>0.25</b>	<b>0.30</b>	<b>0.33</b>	<b>0.35</b>	<b>0.40</b>	<b>0.50</b>	<b>0.60</b>	<b>0.70</b>	<b>0.80</b>	<b>0.90</b>	<b>1.00</b>	<b>1.25</b>	<b>1.50</b>	<b>2.00</b>
8'	469	704	939	1173	1408	1564	1643	1877	2347	2816	3285	3755	4224	4693	5867	7040	9387
9'	528	792	1056	1320	1584	1760	1848	2112	2640	3168	3696	4224	4752	5280	6600	7920	10560
10'	587	880	1173	1467	1760	1956	2053	2347	2933	3520	4107	4693	5280	5867	7333	8880	11733
11'	645	968	1291	1613	1936	2151	2259	2581	3227	3872	4517	5163	5808	6453	8067	9680	12907
12'	704	1056	1408	1760	2112	2347	2464	2816	3520	4224	4928	5632	6336	7040	8800	10560	14080
14'	821	1232	1643	2053	2464	2738	2875	3285	4107	4928	5749	6571	7392	8213	10267	12320	16427
15'	880	1320	1760	2200	2640	2933	3080	3520	4400	5280	6160	7040	7920	8800	11000	13200	17600
16'	939	1408	1877	2347	2816	3129	3285	3755	4693	5632	6571	7509	8448	9387	11733	14080	18773
18'	1056	1584	2112	2640	3168	3520	3696	4224	5280	6336	7392	8448	9504	10560	13200	15840	21120
20'	1173	1760	2347	2933	3520	3911	4107	4693	5867	7040	8213	9387	10560	11733	14667	17600	23467
22'	1291	1936	2581	3227	3872	4302	4517	5136	6453	7744	9035	10325	11616	12907	16133	19360	25813
24'	1408	2112	2816	3520	4224	4693	4928	5632	7040	8448	9856	11264	12672	14080	17600	21120	28160
25'	1467	2200	2933	3667	4400	4889	5133	5867	7333	8800	10267	11733	13200	14667	18333	22000	29333
26'	1525	2288	3051	3813	4576	5084	5339	6101	7627	9152	10677	12203	13728	15253	19067	22880	30507
28'	1643	2464	3285	4107	4928	5476	5749	6571	8213	9856	11499	13141	14784	16427	20533	24640	32853
30'	1760	2640	3520	4400	5280	5867	6160	7040	8800	10560	12320	14080	15840	17600	22000	26400	35200

**Table 15**

<b>TONS OF AGGREGATE REQUIRED PER MILE FOR VARIOUS RATES OF APPLICATION</b>															
<b>Width of Area (ft)</b>	<b>Pounds Per Square Yard</b>														
	<b>3#</b>	<b>5#</b>	<b>7#</b>	<b>8#</b>	<b>10#</b>	<b>12#</b>	<b>15#</b>	<b>20#</b>	<b>25#</b>	<b>30#</b>	<b>35#</b>	<b>40#</b>	<b>45#</b>	<b>50#</b>	<b>100#</b>
8'	7.0	12	16	19	23	28	35	47	59	70	82	94	106	117	235
9'	7.9	13	18	21	26	32	40	53	66	79	92	106	119	132	264
10'	8.8	15	20	23	29	35	44	59	73	88	103	116	132	147	293
11'	9.7	16	23	26	32	39	48	65	81	97	113	129	145	161	323
12'	11	18	25	28	35	42	53	70	88	106	123	141	158	176	352
14'	12	20	29	33	41	49	62	82	103	123	144	164	185	205	410
15'	13	22	31	35	44	53	66	88	110	132	154	176	198	220	440
16'	14	23	33	38	47	56	70	94	117	140	164	188	211	235	469
18'	16	26	37	42	53	63	80	106	132	158	185	212	238	264	528
20'	18	29	41	47	59	70	88	118	147	176	205	235	264	293	587
22'	19	32	45	52	65	77	97	129	161	194	226	258	290	323	645
24'	21	35	49	56	70	84	105	141	176	212	246	282	317	352	704
25'	22	37	51	59	73	88	110	147	183	220	257	294	330	366	733
26'	23	38	53	61	76	92	114	152	191	228	267	305	343	381	762
28'	25	41	57	66	82	99	123	164	205	246	287	328	370	410	820
30'	26	44	62	70	88	106	132	176	220	264	308	352	396	440	880

Table 16

CUBIC YARDS OF MATERIAL REQUIRED PER 100 LINEAL FEET FOR VARIOUS LOOSE DEPTHS															
Width of Area (ft)	Cubic Yards of Loose Aggregate Required for Various Depths in Inches														
	1/2"	3/4"	1"	1 1/2"	2"	2 1/2"	3"	3 1/2"	4"	4 1/2"	5"	6"	8"	10"	12"
8'	1.2	1.9	2.5	3.7	4.9	6.2	7.4	8.6	9.9	11.1	12.3	14.8	19.8	24.7	29.6
9'	1.4	2.1	2.8	4.2	5.6	6.9	8.3	9.7	11.1	12.5	13.9	16.7	22.2	27.8	33.3
10'	1.5	2.3	3.1	4.6	6.2	7.7	9.3	10.8	12.3	13.9	15.4	18.5	24.7	30.9	37.0
11'	1.7	2.5	3.4	5.1	6.8	8.5	10.2	11.9	13.6	15.3	17.0	20.4	27.2	34.0	40.7
12'	1.9	2.8	3.7	5.6	7.4	9.3	11.1	13.0	14.8	16.7	18.5	22.2	29.6	37.0	44.4
14'	2.2	3.2	4.3	6.5	8.6	10.8	13.0	15.1	17.3	19.4	21.6	25.9	34.6	43.2	51.9
15'	2.3	3.5	4.6	6.9	9.3	11.6	13.9	16.2	18.5	20.8	23.1	27.8	37.0	46.3	55.6
16'	2.5	3.7	4.9	7.4	9.9	12.3	14.8	17.3	19.8	22.2	24.7	29.7	39.5	49.4	59.3
18'	2.8	4.2	5.6	8.3	11.1	13.9	16.7	19.4	22.2	25.0	27.8	33.3	44.4	55.6	66.7
20'	3.1	4.6	6.2	9.3	12.3	15.4	18.5	21.6	24.7	27.8	30.9	37.0	49.4	61.7	74.1
22'	3.4	5.1	6.8	10.2	13.6	17.0	20.4	23.8	27.2	30.6	34.0	40.7	54.3	67.9	81.5
24'	3.7	5.6	7.4	11.1	14.8	18.5	22.2	25.9	29.6	33.3	37.0	44.4	59.3	74.1	88.9
25'	3.9	5.8	7.7	11.6	15.4	19.3	23.1	27.0	30.9	34.8	38.6	46.3	61.7	77.2	92.6
26'	4.0	6.0	8.0	12.0	16.0	20.1	24.1	28.1	32.1	36.1	40.1	48.1	64.2	80.2	96.3
28'	4.3	6.5	8.6	13.0	17.3	21.6	26.0	30.2	34.6	38.9	43.2	51.9	69.1	86.4	103.7
30'	4.6	6.9	9.3	13.9	18.6	23.1	27.8	32.4	37.0	41.7	46.3	55.6	74.1	92.6	111.1

APPENDIX B

**Updated Conversions**

## **Linear and Conversions**

12 inches = 1 foot

3 feet = 1 yard

5,280 feet = 1 mile

3,696 feet = 0.7 mile

3,168 feet = 0.6 mile

2,640 feet = 0.5 mile

2,112 feet = 0.4 mile

1,584 feet = 0.3 mile

1,056 feet = 0.2 mile

528 feet = 0.1 mile

264 feet = 0.05 mile

52.8 feet = 0.01 mile

9 square feet = 1 square yard

### **Conversion Factors #1**

1 centimeter = 0.39 inch

1 inch = 2.54 centimeters

1 meter = 39.37 inches

1 foot = 0.305 meter

1 meter = 3.28 feet

1 yard = 0.914 meter

1 meter = 1.094 yards

1 kilometer = 0.62 mile

1 mile = 1.609 kilometers

### **Conversion Factors #2**

1 milliliter = 0.034 fluid ounce

1 fluid ounce = 29.6 milliliters

1 U.S. quart = 0.946 liter

1 liter = 1.06 U.S. quarts

1 U.S. gallon = 3.8 liters

1 imperial gallon = 1.2 U.S. gallons = 4.5 liters

### **Conversion Factors #3**

1 short ton = 0.9 metric ton  
1 metric ton = 1.1 short tons

### **Other Conversion Factors**

cubic feet x 0.03704 = cubic yards  
cubic feet x 7.481 = gallons

cubic yards x 27 = cubic feet  
cubic yards x 202 = gallons

feet x 30.48 = centimeters  
feet x 12 = inches  
feet x 0.3048 = meters

gallons x 8 = pints  
gallons x 4 = quarts

inches x 2.540 = centimeters

meters x 3.2808 = feet  
meters x 39.37 = inches

meters x 1.0936 = yards

miles x 5,280 = feet  
miles x 1.6093 = kilometers  
miles x 1760 = yards

pounds x 16 = ounces

square feet x 144 = inches  
square feet x 1/9 = square yards

tons (long) x 2,240 = pounds  
tons (short) x 2,000 = pounds

## **U. S. - METRIC EQUIVALENTS**

### **LINEAR MEASURE**

1 inch = 25.4 millimeters  
= 2.54 centimeters

1 foot = 30.48 centimeters  
= 0.3048 meter

1 yard = 0.9144 meter

1 mile = 1,609.3 meters  
= 1.6093 kilometers

0.03937 inch = 1 millimeter

0.3937 inch = 1 centimeter

39.37 inches = 1 meter

3.2808 feet = 1 meter

1.0936 yards = 1 meter

3,280 feet = 1 kilometer

1,093.6 yards = 1 kilometer

0.62137 mile = 1 kilometer



## **LIQUID MEASURE**

1 fluid ounce = 29.573 milliliters

1 quart = 0.94635 liter

1 gallon = 3.7854 liters

33.814 fluid ounces = 1 liter

1.0567 quarts = 1 liter

## **Length**

### **Metric System**

1 millimeter = 1/1,000 meter

1 centimeter = 1/100 meter

1 kilometer = 1,000 meters

### **American and British Units**

1 inch = 1/36 yard = 1/12 foot

1 foot = 1/3 yard

1 yard (basic unit of length)

1 rod = 5 1/2 yards

1 mile = 1,760 yards = 5,280 feet

## Area

### **American and British Units**

1 square inch = 1/1,296 square yard = 1/144 square foot  
1 square foot = 1/9 square yard  
1 square yard (basic unit of area)  
1 acre = 4,840 square yards = 160 square rods  
1 square mile = 3,097,600 square yards = 640 acres

## Volume and Capacity (Liquid and Dry)

### **American and British Units**

1 cubic inch = 1/46,656 cubic yard = 1/1,728 cubic foot  
1 cubic foot = 1/27 cubic yard  
1 cubic yard (basic unit of volume)  
1 U.S. fluid ounce = 1/128 U.S. gallon = 1/16 U.S. pint  
1 pint = 1/8 gallon = 1/2 quart  
1 quart = 1/4 gallon

## **Weight (Mass)**

### **American and British Units: Avoirdupois**

1 ounce = 1/16 pound  
1 pound = 16 ounces (basic unit of weight or mass)  
1 short ton = 2,000 pounds  
1 long ton = 2,240 pounds

## ENGLISH TO SI (METRIC) CONVERSION FACTORS

### LENGTH

<b>SYMBOL</b>	<b>WHEN YOU KNOW</b>	<b>MULTIPLY BY</b>	<b>TO FIND</b>	<b>SYMBOL</b>
in	inches	25.4	millimeters	mm
ft	feet	0.3048	meters	m
yd	yards	0.9144	meters	m
mi	miles	1.609347	kilometers	k

### AREA

<b>SYMBOL</b>	<b>WHEN YOU KNOW</b>	<b>MULTIPLY BY</b>	<b>TO FIND</b>	<b>SYMBOL</b>
in <sup>2</sup>	square inches	645.16	square millimeters	mm <sup>2</sup>
ft <sup>2</sup>	square feet	0.09290304	square meters	m <sup>2</sup>
yd <sup>2</sup>	square yards	0.8361274	square meters	m <sup>2</sup>
mi <sup>2</sup>	square miles	2.589998	square kilometers	km <sup>2</sup>

### VOLUME

<b>SYMBOL</b>	<b>WHEN YOU KNOW</b>	<b>MULTIPLY BY</b>	<b>TO FIND<sup>2</sup></b>	<b>SYMBOL</b>
fl oz	fluid ounces	29.57353	milliliters	mL
gal	gallons	3.785412	liters	L
ft <sup>3</sup>	cubic feet	0.02831685	cubic meters	m <sup>3</sup>
yd <sup>3</sup>	cubic yards	0.7645549	cubic meters	m <sup>3</sup>

**MASS**

<b>SYMBOL</b>	<b>WHEN YOU KNOW</b>	<b>MULTIPLY BY</b>	<b>TO FIND<sup>2</sup></b>	<b>SYMBOL</b>
oz	ounces	28.34952	grams	g
lb	pounds	0.4535924	kilograms	kg
T	2000 pounds	0.9071847	metric tons	t

**TEMPERATURE**

<b>SYMBOL</b>	<b>WHEN YOU KNOW</b>	<b>MULTIPLY BY</b>	<b>TO FIND<sup>2</sup></b>	<b>SYMBOL</b>
°F	Fahrenheit	$C = (F - 32) / 1.8$	Celsius	°C
°C	Celsius	$F = 1.8C + 32$	Fahrenheit	°F

## SI (METRIC) TO ENGLISH CONVERSION FACTORS

### LENGTH

Symbol	When You Know	Multiply By	To Find	Symbol
cm	centimeters	0.3937	Inches	in
mm	millimeters	0.03937	inches	in
m	meters	3.28084	feet	ft
m	meters	1.093613	yards	yd
km	kilometers	0.62137	miles	mi

### AREA

Symbol	When You Know	Multiply By	To Find	Symbol
mm <sup>2</sup>	square millimeters	0.00155	square inches	in <sup>2</sup>
m <sup>2</sup>	square meters	10.76391	square feet	ft <sup>2</sup>
m <sup>2</sup>	square meters	1.19599	square yards	yd <sup>2</sup>
m <sup>2</sup>	square meters	0.000247	acres	ac
km <sup>2</sup>	square kilometers	0.3861	square miles	mi <sup>2</sup>

### VOLUME

Symbol	When You Know	Multiply By	To Find	Symbol
mL	milliliters	0.033814	fluid ounces	fl oz
L	liters	0.264172	gallons	gal
m <sup>3</sup>	cubic meters	35.31466	cubic feet	ft <sup>3</sup>
m <sup>3</sup>	cubic meters	1.30795	cubic yard	yd <sup>3</sup>

### MASS

Symbol	When You Know	Multiply By	To Find	Symbol
g	grams	0.035274	ounces	oz
kg	kilograms	2.204622	pounds	lb
t	metric tons	1.1023114	2000 pounds	T

# WEIGHTS AND MEASURES

## U. S. SYSTEM

## METRIC SYSTEM

<b>LINEAR MEASURE</b>	<b>LINEAR MEASURE</b>
12 inches = 1 foot	10 millimeters = 1 centimeter
3 feet = 1 yard	10 centimeters = 1 decimeter
5.5 yards = 1 rod	10 decimeters = 1 meter
<b>SQUARE MEASURE</b>	<b>SQUARE MEASURE</b>
144 sq. inches = 1 sq. ft.	100 sq. millimeters = 1 sq. centimeter
9 sq. feet = 1 sq. yd.	100 sq. centimeters = 1 sq. decimeter
640 acres = 1 sq. mi.	100 sq. decimeters = 1 sq. meter
<b>CUBIC MEASURE</b>	<b>CUBIC MEASURE</b>
1,278 cu. in. = 1 cu. Ft.	1,000 cu. millimeters = 1 cu. centimeter
27 cu. ft. = 1 cu. yd.	1,000 cu. centimeters = 1 decimeter
	1,000 cu. decimeters = 1 cu. meter
<b>LIQUID MEASURE</b>	<b>LIQUID MEASURE</b>
2 pts. = 1 qt.	10 milliliters = 1 centiliter
4 quarts = 1 gal.	10 centiliters = 1 deciliter
31 ½ gal. = 1 barrel	10 deciliters = 1 liter
	10 liters = 1 decaliter
<b>DRY MEASURE</b>	
2 pts = 1 qt.	
8 qt. = 1 peck	
4 pecks = 1 bu.	
<b>FLUID MEASURE</b>	
16 fl. ounces = 1 pt.	
2 pts. = 1 qt.	
4 qts. = 1 gal.	
<b>WEIGHTS</b>	<b>WEIGHTS</b>
12 ounces = 1 pound	10 milligrams = 1 centigram
	10 centigrams = 1 decigram
	10 decigrams = 1 gram
	10 grams = 1 decagram

## Examples: Calculation Aids

1) You are pouring a slab that is 30' by 30' and 6" thick and three footings that are 20' by 12" by 12".

First you need to put all the dimensions in the same units. I am going to choose feet. Thus the slab dimensions in feet are 30 by 30 by  $\frac{1}{2}$ . Hence the volume of concrete in the slab is  $30 \times 30 \times \frac{1}{2} = 450$  cubic feet.

One yard is three feet so a cubic yard is three feet by three feet by three feet.  $3 \times 3 \times 3 = 27$  and hence 1 cubic yard is 27 cubic feet.

Thus the volume of concrete in the slab is  $\frac{450}{27} = 16.7$  cubic yards.

In a similar fashion each footing has a volume of  $20 \times 1 \times 1 = 20$  cubic feet

which is  $\frac{20}{27} = 0.74$  cubic yards.

Thus you need  $16.7 + 3 \times 0.74 = 18.92$  cubic yards.

2) Swath mile conversion for mowing operations:

If an odd shaped field is mowed, such as an infield, the swath miles can be determined by using dimensions found on the construction plans.

Area measured in acres can be converted to swath miles by multiplying the acreage by 1.65\*.

For example, if a mowed field has an area of 12.68 acres, the number of swath miles would be  $12.68 \times 1.65 = 20.9$  or 21 swath miles.

If the number of acres of a given area must be determined in the field, multiply length time width of the area to calculate number of square feet.

Divide this figure by 43,560 square feet (the number of square feet in 1 acre) to calculate the acreage of the given area. Acreage  $\times$  1.65, as in the previous example, converts to swath miles.

*\*Note: Conversion from acres to swath miles:*

1 swath mile = .61 acre

or . . . . 1 acre = 1.65 swath mile

#3) There is a limit to how much salt can be stored in a given area. From certain facts about salt's physical characteristics, we can determine in advance how much space a known amount will occupy.

When deicing salt falls freely into a pile, it forms a cone with sides that slope at an angle of 32 degrees, salt's natural angle of repose.

The density of deicing salt ranges from 72 pounds per cubic foot loose to 84 pounds compacted. When calculating storage space requirements, use the figure 80 pounds per cubic foot or 2,160 pounds per cubic yard. Thus, a ton of salt would require 25 cubic feet of storage space.



## Area Calculations

### Rectangular Area

Area (square feet) = Length (feet) x Width (feet)

To change to square yards, divide by 9

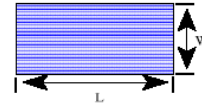

### Trapezoid Area

Width is the average of base "a" and base "b"

Width (feet) =  $\frac{1}{2}$  [a (feet) + b (feet)]

Area (square feet) = Length (feet) x Width (feet)

To change to square yards, divide by 9

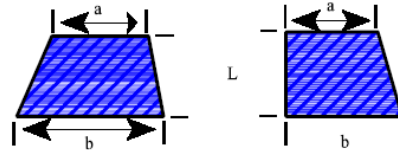

### Circular Area

The radius "R" is the imaginary line that runs from the center of the circle to the rim. To find the area of a circle in square feet, radius (feet) x radius (feet) x 3.14. To change to square yards, divide by 9.

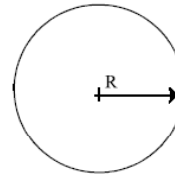

### Oval Area

Area (square feet) =  $\frac{1}{2}$  Length "a" (feet) x  $\frac{1}{2}$  Length "b" (feet) x 3.14.

To change to square yards, divide by 9.

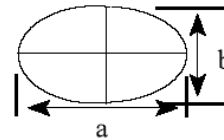

### Triangular Area

Area (square feet) =  $\frac{1}{2}$  Base (feet) x Height (feet)

To change to square yards, divide by 9.

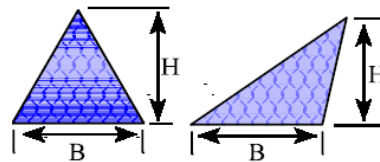

## Formula for geometric figures

### Perimeter formula

$$\text{Square} = 4 * \text{side}$$

$$\text{Rectangle} = 2 * (\text{length} + \text{width})$$

$$\text{Parallelogram} = 2 * (\text{side1} + \text{side2})$$

$$\text{Triangle} = \text{side1} + \text{side2} + \text{side3}$$

$$\text{Circle} = 2 * \text{pi} * \text{radius}$$

### Area formula

$$\text{Square} = \text{side}^2$$

$$\text{Rectangle} = \text{length} * \text{width}$$

$$\text{Triangle} = \text{base} * \text{height} / 2$$

$$\text{Circle} = \text{pi} * \text{radius}^2$$

$$\text{Cone (surface)} = \text{pi} * \text{radius} * \text{side}$$

### Volume formula

$$\text{Cube} = \text{side}^3$$

$$\text{Rectangular Prism} = \text{side1} * \text{side2} * \text{side3}$$

$$\text{Cone} = (1/3) * \text{pi} * \text{radius}^2 * \text{height}$$

$$\text{Pyramid} = (1/3) * (\text{base area}) * \text{height}$$

## APPENDIX A

The six most common types of measures used to estimate quantities for road work are:

- Length
- Area
- Space Volume (containers)
- Liquid Volume
- Weight
- Rate (as in gallons per square yard)

The TABLES and RULES are presented to help with the calculation of surface areas and volumes of containers or material that have three dimensions – length, breadth, and thickness. Terms such as width, height, depth, and base are also used.

**Table of Contents**  
APPENDIX (Pages A-1 through A-21)

	Page A-
Abbreviations .....	1
Acres .....	1, 2
Add.....	1
Area.....	2, 3, 4, 5, 6, 7, 8, 9, 11
Asphalt .....	9
Average.....	1, 9
Calcium .....	10
Capacity .....	12
Center .....	5
Chloride.....	10
Circle.....	5
Circumference.....	1, 5
Cone .....	6, 8
Cylinder.....	6, 11
Decimals .....	2
Deicers .....	9
Depth.....	12
Diameter.....	1, 5
Distance.....	5, 9
Divide.....	1
Factor, Conversion.....	12
Foot .....	2, 9
Gallons .....	1, 2, 9, 10, 12
Grade.....	9
Grams .....	1
Grits.....	9
Height.....	1, 3, 4, 6, 7, 8, 11
Hundredth .....	2
Inches .....	1
Kilogram .....	2

**Table of Contents**  
APPENDIX (Continued)

	Page A-
Lb .....	1, 2, 9, 10
Length .....	1, 2, 3, 6, 7, 11
Level .....	12
Liquid .....	2, 9, 10, 12
Log .....	1
LP, log point.....	1
Maintenance .....	6
Measures .....	2
Mile .....	1, 2, 15
MP, mile post.....	1
Multiply.....	1
Numbers .....	2
Ounces, oz.....	1, 2
Parallelogram .....	3, 4
Percent.....	1, 9
Pi .....	1
Pound .....	2
Pyramid.....	11
Radius .....	1, 5
Rate .....	1, 9
Ratio.....	1, 9
Rectangle.....	3, 4
Rectangular .....	6
Rise .....	9
Salt .....	9
Shapes .....	8
SLM, straight line mile .....	1
Slope .....	9
Solution.....	10
Square .....	1, 2, 3, 4, 9
Squared .....	5
Subtract .....	1, 10
Sum .....	4

**Table of Contents**  
APPENDIX (Continued)

	Page A-
Tables .....	1, 2, 13-20
Tank .....	11, 12
Temperatures.....	10
Ten-Thousandth .....	2
Tenth .....	2
Terms .....	12
Thousandth.....	2
Ton .....	1, 2, 9
Trapezoid .....	4
Trapezoidal .....	7
Triangle.....	4
Triangular.....	7
Vertical.....	9
Volume.....	2, 6, 7, 8, 11
Weight, wt.....	2, 10
Width.....	1, 3, 6, 7
Yard, yd.....	1, 2, 9

**Table 1**

<b>Abbreviations</b>			
Add	+	Circumference	C
Subtract	-	Diameter	D
Multiply	×	Pi ( $\pi$ )	3.14
Divide	÷ /	Radius	R
Ratio or Rate	/ -	Length	L
Equal	=	Height	H
Percent	%	Width	W
Average	Avg.	Base, large	B
Approximate	≈	Base, small	b

**Table 2**

<b>Abbreviations</b>			
Inches	in. or "	Square Inches	sq. in.
Feet	ft. or '	Square Feet	sq. ft. or S.F.
Yards	yd.	Square Yards	sq. yd. or S.Y.
Miles	mi.	Acres	Ac.
Grams	gm.	Cubic Inches	cu. in.
Ounces	oz.	Cubic Feet	cu. ft. or C.F.
Pounds	lbs.	Cubic Yards	cu. yd. or C.Y.
Tons	Ton	Straight Line Mile	SLM
Gallons	gal.	Mile Post	MP
Hours	hr.	Log Point	LP

**Table 3**

Length Measures			Volume Measures	
<u>Foot</u>	<u>Yard</u>	<u>Mile</u>	<u>Cubic Foot</u>	<u>Cubic Yard</u>
12 in	36 in	5280 ft	1728 cu. in.	27 cu. ft.
	3 ft	1760 yds		

**Table 4****Table 5**

Weight Measures			Liquid Measures	
<u>Kilogram</u>	<u>Pound</u>	<u>Ton</u>	<u>Cubic Foot</u>	<u>Gallon</u>
1000 gms	16 oz	2000 lbs	7.5 gals	0.1337 cu. ft.

**Table 6****Table 7**

Area Measures		
<u>Square Foot</u>	<u>Square Yard</u>	<u>Acre</u>
144 sq in	9 sq ft	43,560 sq ft

**Table 8**

Decimals		
<u>Places</u>	<u>Numbers</u>	<u>Expression</u>
one	0.1	Tenth
two	0.01	Hundredth
three	0.001	Thousandth
four	0.0001	Ten-Thousandth



AREAS OF SURFACES

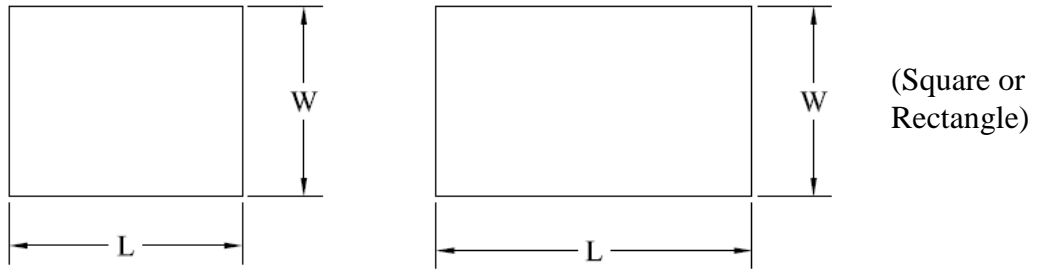

Rule 1: The area (A) of a square or rectangle is calculated by multiplying the length (L) by the width (W).  $A = L \times W$

\* \* \* \* \*

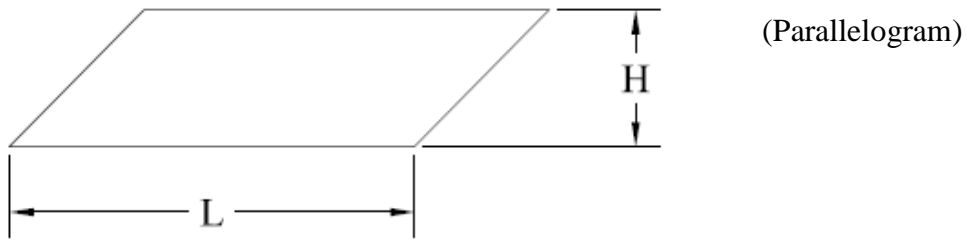

Rule 2: The area (A) of a parallelogram is calculated by multiplying the length (L) times the height (H).  $A = L \times H$

## AREAS

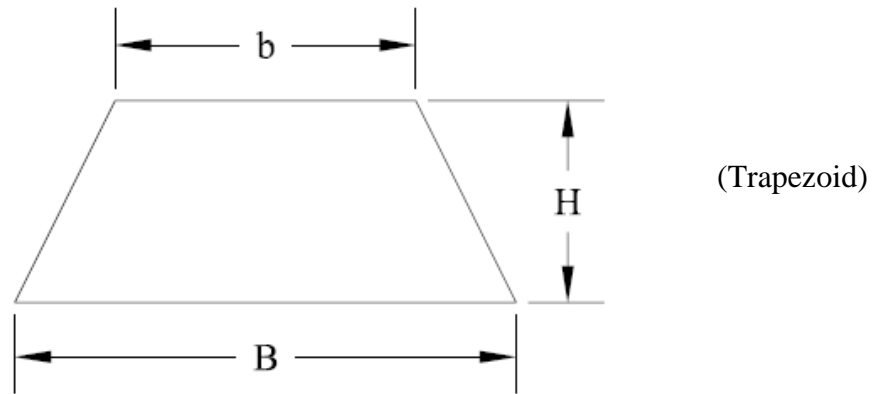

Rule 3: The area (A) of a trapezoid is calculated by multiplying the height (H) times one-half the sum of the bases.  $A = H \times \frac{1}{2} (B + b)$

\* \* \* \* \*

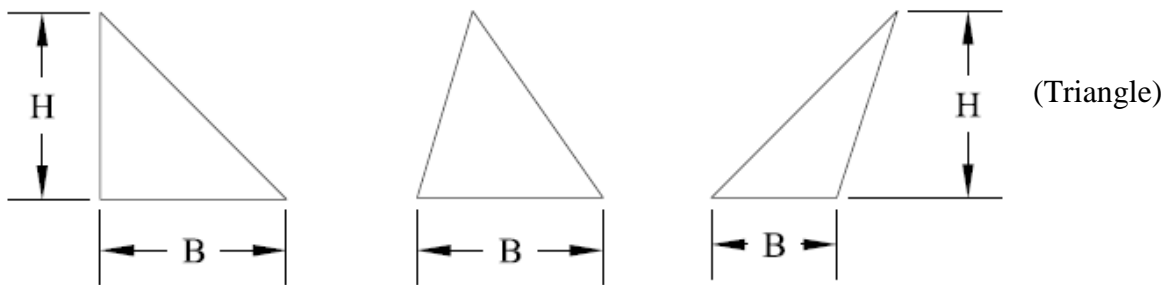

Rule 4: The area (A) of a triangle is calculated by multiplying the base (B) times the height (H) and dividing the answer by 2.  $A = \frac{1}{2} (B \times H)$

(Triangles are  $\frac{1}{2}$  a square, rectangle, or parallelogram.)

## AREAS

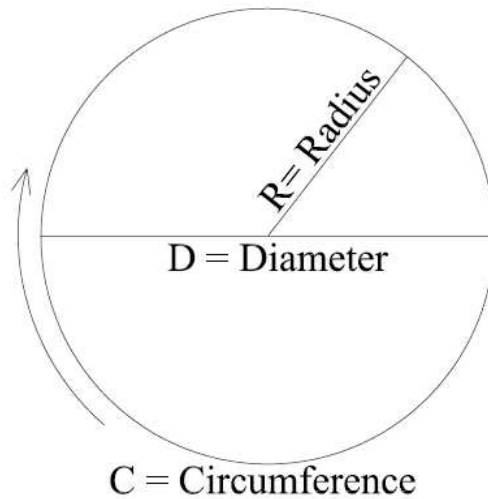

(Circle)

- Circumference is the distance around a circle
- Diameter is a straight line through the center of a circle
- Radius equals half the diameter
- Circumference =  $3.14 \times \text{Diameter}$  or  $3.14 \times 2 \times R$

Rule 5: The area (A) of a circle is calculated by multiplying 3.14 times the radius (R) times the radius (R).  $A = 3.14 \times R \times R$  also written as  $A = 3.14R^2$  (R squared)

## VOLUMES

There are many shapes, the most common of which are boxes, cylinders, and cones. Rules for calculating the volumes or contents that are most used for highway maintenance and repair work are as follows:

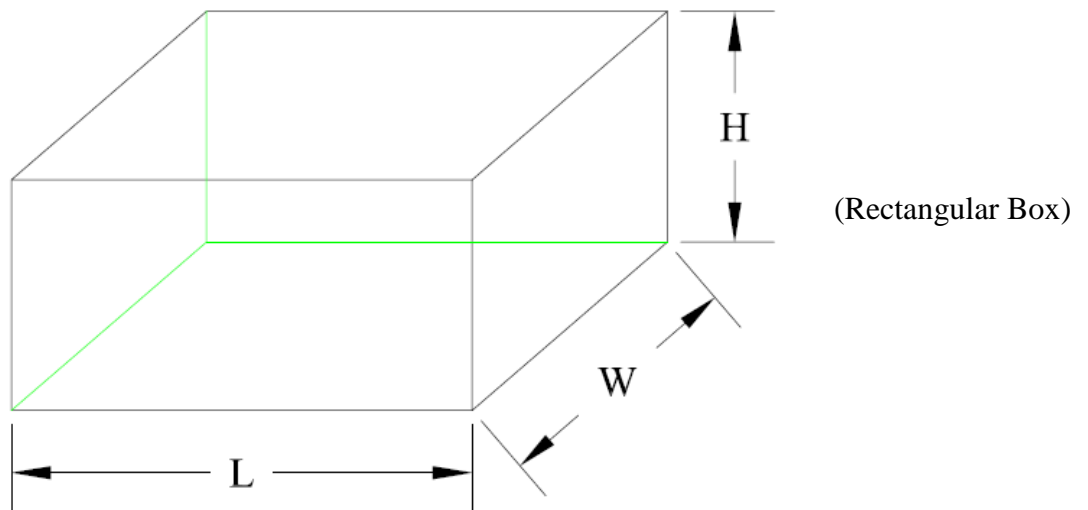

Rule 6: The volume (V) of a rectangular box is calculated by multiplying the length (L) times the width (W) times the height (H).  $V = L \times W \times H$ .  
Using Rule 1 we could say the volume can be obtained by multiplying the area (L x W) x height (H).

## VOLUMES

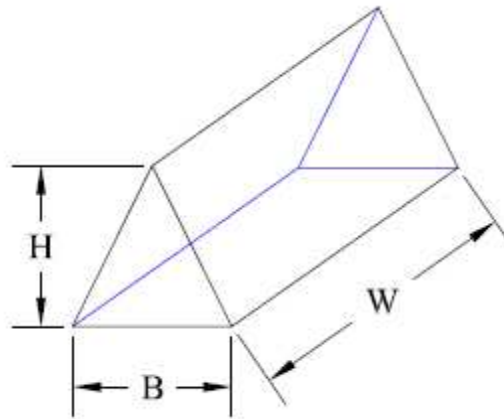

(Triangular Box)

Rule 7: The volume (V) of a triangular box is calculated by multiplying the base (B) times the width (W) and the height (H) and dividing this answer by 2.  
 $V = \frac{1}{2} (B \times W \times H)$

\* \* \* \* \*

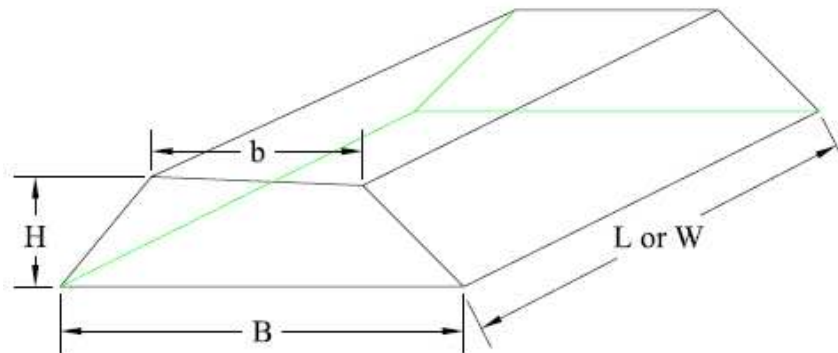

(Trapezoidal Box)

Rule 8: The volume (V) of a trapezoidal box is calculated by multiplying the area (A) of the trapezoidal side by the length (L) or width (W).  
 $V = \frac{1}{2} (B + b) \times H \times L$

## VOLUMES

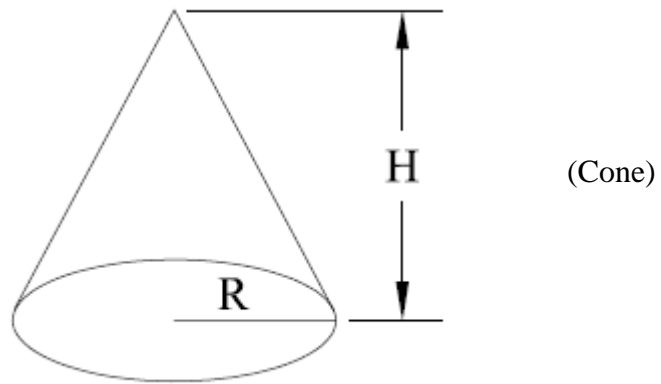

Rule 9: The volume (V) of a cone is calculated by multiplying the area (A) of the base by the height of the cone and dividing by 3.

$$V = 3.14 \times \frac{1}{3} (R \times R) \times H \quad \text{or}$$

$$V = 3.14 \times \frac{1}{3} (R^2) \times H$$

$$\text{Rule 10: Average} = \frac{\text{Total of items added}}{\text{Number of items}}$$

$$\text{Rule 11: Slope ratio} = \frac{\text{Horizontal distance}}{\text{Vertical rise or fall}}$$

Slope ratios are expressed as 3:1, 4:1, etc., meaning 3 ft to 1 ft, 4 ft to 1 ft. The first number is the horizontal distance and the second number is the vertical distance.

$$\text{Rule 12: Percent grade} = \frac{\text{Vertical rise or fall}}{\text{Horizontal distance}} \times 100$$

$$\text{Rule 13: Liquid asphalt application rate (in gallons per square yard)} \\ = \frac{\text{Number of gallons used}}{\text{Area covered in square yards}}$$

$$\text{Rule 14: Area covered by liquid asphalt in square yards} \\ = \frac{\text{Number of gallons used}}{\text{Liquid asphalt application rate (gal./sq.yd.)}}$$

$$\text{Rule 15: Area covered by deicers in square yards} \\ = \frac{\text{Tons of salt} \times 2,000}{\text{Salt/sand application rate (lbs./2 - lane mi)}}$$

Rule 16: Liquid Calcium Chloride					
% Calcium Chloride Solution	Specific Gravity @ 77° F	WT lbs per Gal	% Calcium Chloride Solution	Specific Gravity @ 77° F	WT lbs per Gal
30 (29.5-30.5)	1.295 1.291-1.301	10.76	37 (35.6-37.4)	1.379 1.374-1.384	11.46
31 (30.6-31.4)	1.306 1.302-1.312	10.85	38 (37.5-38.5)	1.391 1.385-1.397	11.56
32 (31.5-32.5)	1.318 1.313-1.325	10.95	39 (38.6-39.4)	1.403 1.398-1.408	11.66
33 (32.6-33.4)	1.331 1.326-1.336	11.06	40 (39.5-40.5)	1.415 1.409-1.421	11.76
34 (33.5-34.5)	1.342 1.337-1.349	11.15	41 (40.6-41.4)	1.426 1.422-1.431	11.85
35 (34.6-35.4)	1.355 1.350-1.360	11.26	42 (41.5-42.5)	1.438 1.432-1.444	11.95
36 (35.5-36.5)	1.366 1.361-1.373	11.35			

NOTE: For temperatures above 77° F, subtract 0.0003 specific gravity units per degree F.

Weight = Specific Gravity x 8.33 lbs



VOLUMES

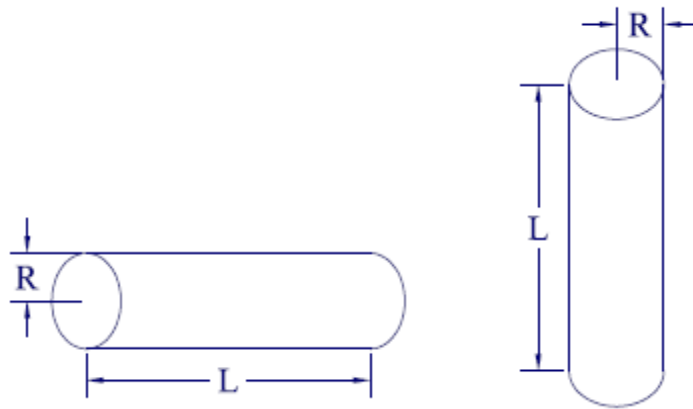

Rule 17: The volume (V) of a cylinder or tank is calculated by multiplying the area (A) of the base or end by the height (H) or length (L) of the object.  
 $V = 3.14 \times R \times R \times L$

\* \* \* \* \*

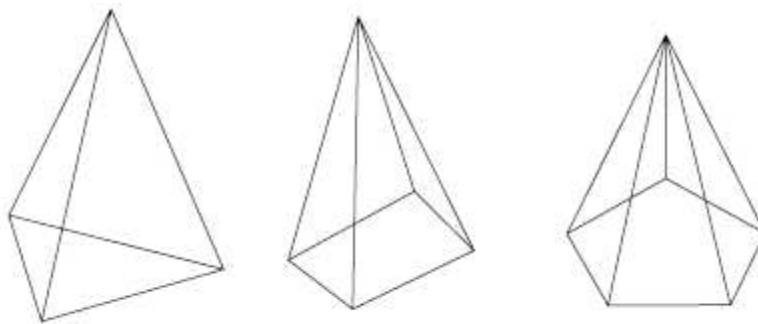

Rule 18: The volume of a pyramid is one-third its base area times its altitude.

Rule 19: Estimating the number of gallons in a tank.  
 Gallons = Conversion Factor x Tank Capacity

Liquid Depth	Conversion Factor
0.16D	0.10
0.21D	0.15
0.25D	0.20
0.30D	0.25
0.34D	0.30
0.38D	0.35
0.42D	0.40
0.46D	0.45
0.50D	0.50
0.54D	0.55
0.58D	0.60
0.62D	0.65
0.66D	0.70
0.70D	0.75
0.75D	0.80
0.79D	0.85
0.84D	0.90
0.90D	0.95

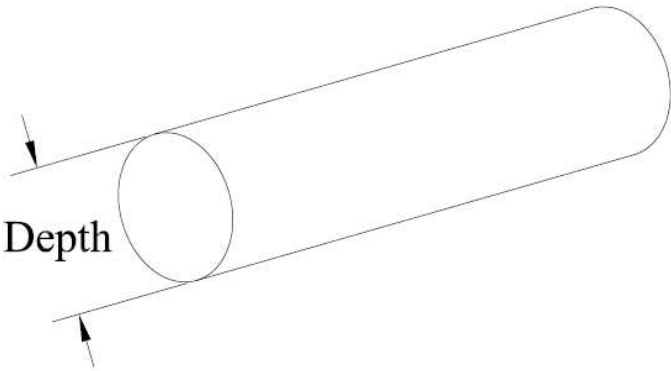

$$\text{LIQUID DEPTH} = \frac{\text{DEPTH FROM BOTTOM}}{\text{DEPTH OF TANK}}$$

Example: Capacity of the tank is 1,000 gallons. Depth is 4 ft. Level of liquid in the tank is 2 ft 3 in from the bottom of the tank. How many gallons are left in the tank?

Answer: Liquid depth is in terms of "D" = 2.25 ft / 4 ft or 0.56D. Since we are estimating the gallons, we can use this chart two ways:

- (1) 0.56D is between 0.54D and 0.58D so we use a Conversion Factor of 0.575. Gallons left in the tank = 0.575 x 1,000 or 575 gallons.
- (2) Or, you could go to the nearest factor in the chart (0.60) and estimate that there are 0.60 x 1,000 or 600 gallons. If you chose to go to the lower factor of 0.55 you would get 0.55 x 1,000 or 550 gallons.

The exact answer is 576 gallons. So, you can make a good estimate by using this chart.

**Table 9**

<b>LINEAL FEET COVERED BY 1000 GALLON TANK</b>								
<b>Road Width (ft)</b>	<b>Gallons Per Square Yard</b>							
	<b>0.60</b>	<b>0.70</b>	<b>0.80</b>	<b>0.90</b>	<b>1.00</b>	<b>1.25</b>	<b>1.50</b>	<b>2.00</b>
8'	1,875	1,607	1,406	1,250	1,125	900	750	563
9'	1,667	1,429	1,250	1,111	1,000	800	667	500
10'	1,500	1,286	1,125	1,000	900	720	600	450
11'	1,364	1,169	1,023	909	818	655	545	409
12'	1,250	1,071	938	833	750	600	500	375
14'	1,071	918	804	714	643	514	429	321
15'	1,000	857	750	667	600	480	400	300
16'	938	804	703	625	563	450	375	281
18'	833	714	625	556	500	400	333	250
20'	750	643	563	500	450	360	300	225
22'	682	584	511	455	409	327	273	205
24'	625	536	469	417	375	300	250	188
25'	600	514	450	400	360	288	240	180
26'	577	495	433	385	346	277	231	173
28'	536	459	402	357	321	257	214	161
30'	500	429	375	333	300	240	200	150

Table 10

<b>LINEAL FEET COVERED BY 1000 GALLON TANK</b>									
<b>Road Width (ft)</b>	<b>Gallons Per Square Yard</b>								
	<b>0.10</b>	<b>0.15</b>	<b>0.20</b>	<b>0.25</b>	<b>0.30</b>	<b>0.33</b>	<b>0.35</b>	<b>0.40</b>	<b>0.50</b>
8'	11,250	7,500	5,625	4,500	3,750	3,375	3,214	2,813	2,250
9'	10,000	6,667	5,000	4,000	3,333	3,000	2,857	2,500	2,000
10'	9,000	6,000	4,500	3,600	3,000	2,700	2,571	2,250	1,800
11'	8,182	5,455	4,091	3,273	2,727	2,455	2,338	2,045	1,636
12'	7,500	5,000	3,750	3,000	2,500	2,250	2,143	1,875	1,500
14'	6,429	4,286	3,214	2,571	2,143	1,929	1,837	1,607	1,286
15'	6,000	4,000	3,000	2,400	2,000	1,800	1,714	1,500	1,200
16'	5,625	3,750	2,813	2,250	1,875	1,688	1,607	1,406	1,125
18'	5,000	3,333	2,500	2,000	1,667	1,500	1,429	1,250	1,000
20'	4,500	3,000	2,250	1,800	1,500	1,350	1,286	1,125	900
22'	4,091	2,727	2,045	1,636	1,364	1,227	1,169	1,023	818
24'	3,750	2,500	1,875	1,500	1,250	1,125	1,071	938	750
25'	3,600	2,400	1,800	1,400	1,200	1,080	1,039	900	720
26'	3,462	2,308	1,731	1,385	1,154	1,038	989	865	692
28'	3,214	2,143	1,607	1,286	1,071	964	918	804	643
30'	3,000	2,000	1,500	1,200	1,000	900	857	750	600

Table 11

<b>SQUARE YARDS OF ROAD SURFACE FOR VARIOUS ROAD WIDTHS</b>			
<b>Road Width</b>	<b>Square Yards of Road Surface</b>		
	<b>Per Linear Foot</b>	<b>Per 100 Feet</b>	<b>Per Mile</b>
6'	0.67	66.67	3,520
7'	0.78	77.78	4,107
8'	0.89	88.89	4,693
9'	1.00	100.00	5,280
10'	1.11	111.11	5,867
11'	1.22	122.22	6,453
12'	1.33	133.33	7,040
13'	1.44	144.44	7,627
14'	1.56	155.56	8,213
15'	1.67	166.67	8,800
16'	1.78	177.78	9,387
17'	1.89	188.89	9,973
18'	2.00	200.00	10,560
20'	2.22	222.22	11,733
22'	2.44	244.44	12,907
24'	2.67	266.67	14,080
25'	2.78	277.78	14,667
26'	2.89	288.89	15,253
28'	3.11	311.11	16,427
30'	3.33	333.33	17,600
32'	3.56	355.56	18,773
34'	3.78	377.78	19,947
36'	4.00	400.00	21,120
38'	4.22	422.22	22,293
40'	4.44	444.44	23,467
50'	5.56	555.56	29,333
60'	6.67	666.67	35,200
70'	7.78	777.78	41,067
75'	8.33	833.33	44,000
80'	8.89	888.89	46,933

Table 12

NUMBER OF GALLONS IN A 1000 GALLON TANK (BASED ON PERCENT OF CAPACITY)						
Percent of Depth	Percent of Capacity	Gallons		Percent of Depth	Percent of Capacity	Gallons
1	0.2	2		26	20.7	207
2	0.5	5		27	21.9	219
3	0.9	9		28	23.0	230
4	1.3	13		29	24.1	241
5	1.9	19		30	25.3	253
6	2.5	25		31	26.5	265
7	3.1	31		32	27.7	277
8	3.7	37		33	28.8	288
9	4.5	45		34	30.0	300
10	5.2	52		35	31.2	312
11	6.0	60		36	32.4	324
12	6.8	68		37	33.7	337
13	7.6	76		38	34.9	349
14	8.5	85		39	36.1	361
15	9.4	94		40	37.4	374
16	10.3	103		41	38.6	386
17	11.3	113		42	39.9	399
18	12.2	122		43	41.1	411
19	13.2	132		44	42.4	424
20	14.2	142		45	43.7	437
21	15.3	153		46	44.9	449
22	16.3	163		47	46.2	462
23	17.4	174		48	47.5	475
24	18.5	185		49	48.7	487
25	19.6	196		50	50.0	500

Table 13

POUNDS OF AGGREGATE REQUIRED PER SQ.YD. FOR VARIOUS CUBIC YARD WEIGHTS												
Pounds of Aggregate Per	Pounds of Compacted Aggregate Per Square Yard for Various Depths in Inches											
	1"	2"	3"	4"	5"	6"	7"	8"	9"	10"	11"	12"
1800	50	100	150	200	250	300	350	400	450	500	550	600
1900	53	106	158	211	264	317	369	422	475	528	581	633
2000	56	111	167	222	278	333	389	444	500	556	611	667
2100	58	117	175	233	292	350	408	467	525	583	642	700
2200	61	122	183	244	306	367	428	489	550	611	672	733
2300	64	128	192	256	319	383	447	511	575	639	703	767
2400	67	133	200	267	333	400	467	533	600	667	733	800
2500	69	139	208	278	347	417	486	556	625	694	761	833
2600	72	144	217	289	361	433	506	578	650	722	791	867
2700	75	150	225	300	375	450	525	600	675	750	825	900
2800	78	156	233	311	389	467	544	622	700	778	856	933
2900	81	161	242	322	403	483	564	644	725	806	886	967
3000	83	167	250	333	417	500	583	667	750	833	917	1000
3100	86	172	258	344	431	517	603	689	775	861	947	1033
3200	89	178	267	356	444	533	622	711	800	889	978	1067
3300	92	183	275	367	458	550	642	733	825	917	1008	1100
3400	94	189	283	378	472	567	661	756	850	944	1039	1133
3500	97	194	292	389	486	583	681	778	875	972	1069	1167
3600	100	200	300	400	500	600	700	800	900	1000	1100	1200

**Table 14**

<b>GALLONS OF ASPHALT REQUIRED PER MILE FOR VARIOUS RATES OF APPLICATION</b>																	
<b>Road Width</b>	<b>Gallons Per Square Yard</b>																
	<b>0.10</b>	<b>0.15</b>	<b>0.20</b>	<b>0.25</b>	<b>0.30</b>	<b>0.33</b>	<b>0.35</b>	<b>0.40</b>	<b>0.50</b>	<b>0.60</b>	<b>0.70</b>	<b>0.80</b>	<b>0.90</b>	<b>1.00</b>	<b>1.25</b>	<b>1.50</b>	<b>2.00</b>
8'	469	704	939	1173	1408	1564	1643	1877	2347	2816	3285	3755	4224	4693	5867	7040	9387
9'	528	792	1056	1320	1584	1760	1848	2112	2640	3168	3696	4224	4752	5280	6600	7920	10560
10'	587	880	1173	1467	1760	1956	2053	2347	2933	3520	4107	4693	5280	5867	7333	8880	11733
11'	645	968	1291	1613	1936	2151	2259	2581	3227	3872	4517	5163	5808	6453	8067	9680	12907
12'	704	1056	1408	1760	2112	2347	2464	2816	3520	4224	4928	5632	6336	7040	8800	10560	14080
14'	821	1232	1643	2053	2464	2738	2875	3285	4107	4928	5749	6571	7392	8213	10267	12320	16427
15'	880	1320	1760	2200	2640	2933	3080	3520	4400	5280	6160	7040	7920	8800	11000	13200	17600
16'	939	1408	1877	2347	2816	3129	3285	3755	4693	5632	6571	7509	8448	9387	11733	14080	18773
18'	1056	1584	2112	2640	3168	3520	3696	4224	5280	6336	7392	8448	9504	10560	13200	15840	21120
20'	1173	1760	2347	2933	3520	3911	4107	4693	5867	7040	8213	9387	10560	11733	14667	17600	23467
22'	1291	1936	2581	3227	3872	4302	4517	5136	6453	7744	9035	10325	11616	12907	16133	19360	25813
24'	1408	2112	2816	3520	4224	4693	4928	5632	7040	8448	9856	11264	12672	14080	17600	21120	28160
25'	1467	2200	2933	3667	4400	4889	5133	5867	7333	8800	10267	11733	13200	14667	18333	22000	29333
26'	1525	2288	3051	3813	4576	5084	5339	6101	7627	9152	10677	12203	13728	15253	19067	22880	30507
28'	1643	2464	3285	4107	4928	5476	5749	6571	8213	9856	11499	13141	14784	16427	20533	24640	32853
30'	1760	2640	3520	4400	5280	5867	6160	7040	8800	10560	12320	14080	15840	17600	22000	26400	35200



**Table 15**

<b>TONS OF AGGREGATE REQUIRED PER MILE FOR VARIOUS RATES OF APPLICATION</b>															
<b>Width of Area (ft)</b>	<b>Pounds Per Square Yard</b>														
	<b>3#</b>	<b>5#</b>	<b>7#</b>	<b>8#</b>	<b>10#</b>	<b>12#</b>	<b>15#</b>	<b>20#</b>	<b>25#</b>	<b>30#</b>	<b>35#</b>	<b>40#</b>	<b>45#</b>	<b>50#</b>	<b>100#</b>
8'	7.0	12	16	19	23	28	35	47	59	70	82	94	106	117	235
9'	7.9	13	18	21	26	32	40	53	66	79	92	106	119	132	264
10'	8.8	15	20	23	29	35	44	59	73	88	103	116	132	147	293
11'	9.7	16	23	26	32	39	48	65	81	97	113	129	145	161	323
12'	11	18	25	28	35	42	53	70	88	106	123	141	158	176	352
14'	12	20	29	33	41	49	62	82	103	123	144	164	185	205	410
15'	13	22	31	35	44	53	66	88	110	132	154	176	198	220	440
16'	14	23	33	38	47	56	70	94	117	140	164	188	211	235	469
18'	16	26	37	42	53	63	80	106	132	158	185	212	238	264	528
20'	18	29	41	47	59	70	88	118	147	176	205	235	264	293	587
22'	19	32	45	52	65	77	97	129	161	194	226	258	290	323	645
24'	21	35	49	56	70	84	105	141	176	212	246	282	317	352	704
25'	22	37	51	59	73	88	110	147	183	220	257	294	330	366	733
26'	23	38	53	61	76	92	114	152	191	228	267	305	343	381	762
28'	25	41	57	66	82	99	123	164	205	246	287	328	370	410	820
30'	26	44	62	70	88	106	132	176	220	264	308	352	396	440	880

Table 16

CUBIC YARDS OF MATERIAL REQUIRED PER 100 LINEAL FEET FOR VARIOUS LOOSE DEPTHS															
Width of Area (ft)	Cubic Yards of Loose Aggregate Required for Various Depths in Inches														
	1/2"	3/4"	1"	1 1/2"	2"	2 1/2"	3"	3 1/2"	4"	4 1/2"	5"	6"	8"	10"	12"
8'	1.2	1.9	2.5	3.7	4.9	6.2	7.4	8.6	9.9	11.1	12.3	14.8	19.8	24.7	29.6
9'	1.4	2.1	2.8	4.2	5.6	6.9	8.3	9.7	11.1	12.5	13.9	16.7	22.2	27.8	33.3
10'	1.5	2.3	3.1	4.6	6.2	7.7	9.3	10.8	12.3	13.9	15.4	18.5	24.7	30.9	37.0
11'	1.7	2.5	3.4	5.1	6.8	8.5	10.2	11.9	13.6	15.3	17.0	20.4	27.2	34.0	40.7
12'	1.9	2.8	3.7	5.6	7.4	9.3	11.1	13.0	14.8	16.7	18.5	22.2	29.6	37.0	44.4
14'	2.2	3.2	4.3	6.5	8.6	10.8	13.0	15.1	17.3	19.4	21.6	25.9	34.6	43.2	51.9
15'	2.3	3.5	4.6	6.9	9.3	11.6	13.9	16.2	18.5	20.8	23.1	27.8	37.0	46.3	55.6
16'	2.5	3.7	4.9	7.4	9.9	12.3	14.8	17.3	19.8	22.2	24.7	29.7	39.5	49.4	59.3
18'	2.8	4.2	5.6	8.3	11.1	13.9	16.7	19.4	22.2	25.0	27.8	33.3	44.4	55.6	66.7
20'	3.1	4.6	6.2	9.3	12.3	15.4	18.5	21.6	24.7	27.8	30.9	37.0	49.4	61.7	74.1
22'	3.4	5.1	6.8	10.2	13.6	17.0	20.4	23.8	27.2	30.6	34.0	40.7	54.3	67.9	81.5
24'	3.7	5.6	7.4	11.1	14.8	18.5	22.2	25.9	29.6	33.3	37.0	44.4	59.3	74.1	88.9
25'	3.9	5.8	7.7	11.6	15.4	19.3	23.1	27.0	30.9	34.8	38.6	46.3	61.7	77.2	92.6
26'	4.0	6.0	8.0	12.0	16.0	20.1	24.1	28.1	32.1	36.1	40.1	48.1	64.2	80.2	96.3
28'	4.3	6.5	8.6	13.0	17.3	21.6	26.0	30.2	34.6	38.9	43.2	51.9	69.1	86.4	103.7
30'	4.6	6.9	9.3	13.9	18.6	23.1	27.8	32.4	37.0	41.7	46.3	55.6	74.1	92.6	111.1

APPENDIX B

**Updated Conversions**

## **Linear and Conversions**

12 inches = 1 foot

3 feet = 1 yard

5,280 feet = 1 mile

3,696 feet = 0.7 mile

3,168 feet = 0.6 mile

2,640 feet = 0.5 mile

2,112 feet = 0.4 mile

1,584 feet = 0.3 mile

1,056 feet = 0.2 mile

528 feet = 0.1 mile

264 feet = 0.05 mile

52.8 feet = 0.01 mile

9 square feet = 1 square yard

### **Conversion Factors #1**

1 centimeter = 0.39 inch

1 inch = 2.54 centimeters

1 meter = 39.37 inches

1 foot = 0.305 meter

1 meter = 3.28 feet

1 yard = 0.914 meter

1 meter = 1.094 yards

1 kilometer = 0.62 mile

1 mile = 1.609 kilometers

### **Conversion Factors #2**

1 milliliter = 0.034 fluid ounce

1 fluid ounce = 29.6 milliliters

1 U.S. quart = 0.946 liter

1 liter = 1.06 U.S. quarts

1 U.S. gallon = 3.8 liters

1 imperial gallon = 1.2 U.S. gallons = 4.5 liters

### **Conversion Factors #3**

1 short ton = 0.9 metric ton  
1 metric ton = 1.1 short tons

### **Other Conversion Factors**

cubic feet x 0.03704 = cubic yards  
cubic feet x 7.481 = gallons

cubic yards x 27 = cubic feet  
cubic yards x 202 = gallons

feet x 30.48 = centimeters  
feet x 12 = inches  
feet x 0.3048 = meters

gallons x 8 = pints  
gallons x 4 = quarts

inches x 2.540 = centimeters

meters x 3.2808 = feet  
meters x 39.37 = inches

meters x 1.0936 = yards

miles x 5,280 = feet  
miles x 1.6093 = kilometers  
miles x 1760 = yards

pounds x 16 = ounces

square feet x 144 = inches  
square feet x 1/9 = square yards

tons (long) x 2,240 = pounds  
tons (short) x 2,000 = pounds

## **U. S. - METRIC EQUIVALENTS**

### **LINEAR MEASURE**

$$\begin{aligned} 1 \text{ inch} &= 25.4 \text{ millimeters} \\ &= 2.54 \text{ centimeters} \end{aligned}$$

$$\begin{aligned} 1 \text{ foot} &= 30.48 \text{ centimeters} \\ &= 0.3048 \text{ meter} \end{aligned}$$

$$1 \text{ yard} = 0.9144 \text{ meter}$$

$$\begin{aligned} 1 \text{ mile} &= 1,609.3 \text{ meters} \\ &= 1.6093 \text{ kilometers} \end{aligned}$$

$$0.03937 \text{ inch} = 1 \text{ millimeter}$$

$$0.3937 \text{ inch} = 1 \text{ centimeter}$$

$$39.37 \text{ inches} = 1 \text{ meter}$$

$$3.2808 \text{ feet} = 1 \text{ meter}$$

$$1.0936 \text{ yards} = 1 \text{ meter}$$

$$3,280 \text{ feet} = 1 \text{ kilometer}$$

$$1,093.6 \text{ yards} = 1 \text{ kilometer}$$

$$0.62137 \text{ mile} = 1 \text{ kilometer}$$

## **LIQUID MEASURE**

1 fluid ounce = 29.573 milliliters

1 quart = 0.94635 liter

1 gallon = 3.7854 liters

33.814 fluid ounces = 1 liter

1.0567 quarts = 1 liter

## **Length**

### **Metric System**

1 millimeter = 1/1,000 meter

1 centimeter = 1/100 meter

1 kilometer = 1,000 meters

### **American and British Units**

1 inch = 1/36 yard = 1/12 foot

1 foot = 1/3 yard

1 yard (basic unit of length)

1 rod = 5 1/2 yards

1 mile = 1,760 yards = 5,280 feet

## Area

### **American and British Units**

1 square inch = 1/1,296 square yard = 1/144 square foot  
1 square foot = 1/9 square yard  
1 square yard (basic unit of area)  
1 acre = 4,840 square yards = 160 square rods  
1 square mile = 3,097,600 square yards = 640 acres

## Volume and Capacity (Liquid and Dry)

### **American and British Units**

1 cubic inch = 1/46,656 cubic yard = 1/1,728 cubic foot  
1 cubic foot = 1/27 cubic yard  
1 cubic yard (basic unit of volume)  
1 U.S. fluid ounce = 1/128 U.S. gallon = 1/16 U.S. pint  
1 pint = 1/8 gallon = 1/2 quart  
1 quart = 1/4 gallon

## **Weight (Mass)**

### **American and British Units: Avoirdupois**

1 ounce = 1/16 pound  
1 pound = 16 ounces (basic unit of weight or mass)  
1 short ton = 2,000 pounds  
1 long ton = 2,240 pounds



## ENGLISH TO SI (METRIC) CONVERSION FACTORS

### LENGTH

<b>SYMBOL</b>	<b>WHEN YOU KNOW</b>	<b>MULTIPLY BY</b>	<b>TO FIND</b>	<b>SYMBOL</b>
in	inches	25.4	millimeters	mm
ft	feet	0.3048	meters	m
yd	yards	0.9144	meters	m
mi	miles	1.609347	kilometers	k

### AREA

<b>SYMBOL</b>	<b>WHEN YOU KNOW</b>	<b>MULTIPLY BY</b>	<b>TO FIND</b>	<b>SYMBOL</b>
in <sup>2</sup>	square inches	645.16	square millimeters	mm <sup>2</sup>
ft <sup>2</sup>	square feet	0.09290304	square meters	m <sup>2</sup>
yd <sup>2</sup>	square yards	0.8361274	square meters	m <sup>2</sup>
mi <sup>2</sup>	square miles	2.589998	square kilometers	km <sup>2</sup>

### VOLUME

<b>SYMBOL</b>	<b>WHEN YOU KNOW</b>	<b>MULTIPLY BY</b>	<b>TO FIND<sup>2</sup></b>	<b>SYMBOL</b>
fl oz	fluid ounces	29.57353	milliliters	mL
gal	gallons	3.785412	liters	L
ft <sup>3</sup>	cubic feet	0.02831685	cubic meters	m <sup>3</sup>
yd <sup>3</sup>	cubic yards	0.7645549	cubic meters	m <sup>3</sup>

**MASS**

<b>SYMBOL</b>	<b>WHEN YOU KNOW</b>	<b>MULTIPLY BY</b>	<b>TO FIND<sup>2</sup></b>	<b>SYMBOL</b>
oz	ounces	28.34952	grams	g
lb	pounds	0.4535924	kilograms	kg
T	2000 pounds	0.9071847	metric tons	t

**TEMPERATURE**

<b>SYMBOL</b>	<b>WHEN YOU KNOW</b>	<b>MULTIPLY BY</b>	<b>TO FIND<sup>2</sup></b>	<b>SYMBOL</b>
°F	Fahrenheit	$C = (F - 32) / 1.8$	Celsius	°C
°C	Celsius	$F = 1.8C + 32$	Fahrenheit	°F

## SI (METRIC) TO ENGLISH CONVERSION FACTORS

### LENGTH

Symbol	When You Know	Multiply By	To Find	Symbol
cm	centimeters	0.3937	Inches	in
mm	millimeters	0.03937	inches	in
m	meters	3.28084	feet	ft
m	meters	1.093613	yards	yd
km	kilometers	0.62137	miles	mi

### AREA

Symbol	When You Know	Multiply By	To Find	Symbol
mm <sup>2</sup>	square millimeters	0.00155	square inches	in <sup>2</sup>
m <sup>2</sup>	square meters	10.76391	square feet	ft <sup>2</sup>
m <sup>2</sup>	square meters	1.19599	square yards	yd <sup>2</sup>
m <sup>2</sup>	square meters	0.000247	acres	ac
km <sup>2</sup>	square kilometers	0.3861	square miles	mi <sup>2</sup>

### VOLUME

Symbol	When You Know	Multiply By	To Find	Symbol
mL	milliliters	0.033814	fluid ounces	fl oz
L	liters	0.264172	gallons	gal
m <sup>3</sup>	cubic meters	35.31466	cubic feet	ft <sup>3</sup>
m <sup>3</sup>	cubic meters	1.30795	cubic yard	yd <sup>3</sup>

### MASS

Symbol	When You Know	Multiply By	To Find	Symbol
g	grams	0.035274	ounces	oz
kg	kilograms	2.204622	pounds	lb
t	metric tons	1.1023114	2000 pounds	T

# WEIGHTS AND MEASURES

## U. S. SYSTEM

## METRIC SYSTEM

<b>LINEAR MEASURE</b>	<b>LINEAR MEASURE</b>
12 inches = 1 foot	10 millimeters = 1 centimeter
3 feet = 1 yard	10 centimeters = 1 decimeter
5.5 yards = 1 rod	10 decimeters = 1 meter
<b>SQUARE MEASURE</b>	<b>SQUARE MEASURE</b>
144 sq. inches = 1 sq. ft.	100 sq. millimeters = 1 sq. centimeter
9 sq. feet = 1 sq. yd.	100 sq. centimeters = 1 sq. decimeter
640 acres = 1 sq. mi.	100 sq. decimeters = 1 sq. meter
<b>CUBIC MEASURE</b>	<b>CUBIC MEASURE</b>
1,278 cu. in. = 1 cu. Ft.	1,000 cu. millimeters = 1 cu. centimeter
27 cu. ft. = 1 cu. yd.	1,000 cu. centimeters = 1 decimeter
	1,000 cu. decimeters = 1 cu. meter
<b>LIQUID MEASURE</b>	<b>LIQUID MEASURE</b>
2 pts. = 1 qt.	10 milliliters = 1 centiliter
4 quarts = 1 gal.	10 centiliters = 1 deciliter
31 ½ gal. = 1 barrel	10 deciliters = 1 liter
	10 liters = 1 decaliter
<b>DRY MEASURE</b>	
2 pts = 1 qt.	
8 qt. = 1 peck	
4 pecks = 1 bu.	
<b>FLUID MEASURE</b>	
16 fl. ounces = 1 pt.	
2 pts. = 1 qt.	
4 qts. = 1 gal.	
<b>WEIGHTS</b>	<b>WEIGHTS</b>
12 ounces = 1 pound	10 milligrams = 1 centigram
	10 centigrams = 1 decigram
	10 decigrams = 1 gram
	10 grams = 1 decagram

## Examples: Calculation Aids

1) You are pouring a slab that is 30' by 30' and 6" thick and three footings that are 20' by 12" by 12".

First you need to put all the dimensions in the same units. I am going to choose feet. Thus the slab dimensions in feet are 30 by 30 by  $\frac{1}{2}$ . Hence the volume of concrete in the slab is  $30 \times 30 \times \frac{1}{2} = 450$  cubic feet.

One yard is three feet so a cubic yard is three feet by three feet by three feet.  $3 \times 3 \times 3 = 27$  and hence 1 cubic yard is 27 cubic feet.

Thus the volume of concrete in the slab is  $\frac{450}{27} = 16.7$  cubic yards.

In a similar fashion each footing has a volume of  $20 \times 1 \times 1 = 20$  cubic feet

which is  $\frac{20}{27} = 0.74$  cubic yards.

Thus you need  $16.7 + 3 \times 0.74 = 18.92$  cubic yards.

2) Swath mile conversion for mowing operations:

If an odd shaped field is mowed, such as an infield, the swath miles can be determined by using dimensions found on the construction plans.

Area measured in acres can be converted to swath miles by multiplying the acreage by 1.65\*.

For example, if a mowed field has an area of 12.68 acres, the number of swath miles would be  $12.68 \times 1.65 = 20.9$  or 21 swath miles.

If the number of acres of a given area must be determined in the field, multiply length time width of the area to calculate number of square feet.

Divide this figure by 43,560 square feet (the number of square feet in 1 acre) to calculate the acreage of the given area. Acreage  $\times$  1.65, as in the previous example, converts to swath miles.

*\*Note: Conversion from acres to swath miles:*

1 swath mile = .61 acre

or . . . . 1 acre = 1.65 swath mile

#3) There is a limit to how much salt can be stored in a given area. From certain facts about salt's physical characteristics, we can determine in advance how much space a known amount will occupy.

When deicing salt falls freely into a pile, it forms a cone with sides that slope at an angle of 32 degrees, salt's natural angle of repose.

The density of deicing salt ranges from 72 pounds per cubic foot loose to 84 pounds compacted. When calculating storage space requirements, use the figure 80 pounds per cubic foot or 2,160 pounds per cubic yard. Thus, a ton of salt would require 25 cubic feet of storage space.

## Area Calculations

### Rectangular Area

Area (square feet) = Length (feet) x Width (feet)

To change to square yards, divide by 9

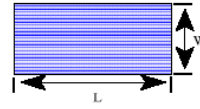

### Trapezoid Area

Width is the average of base "a" and base "b"

Width (feet) =  $\frac{1}{2}$  [a (feet) + b (feet)]

Area (square feet) = Length (feet) x Width (feet)

To change to square yards, divide by 9

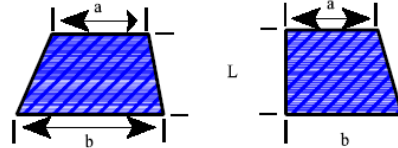

### Circular Area

The radius "R" is the imaginary line that runs from the center of the circle to the rim. To find the area of a circle in square feet, radius (feet) x radius (feet) x 3.14. To change to square yards, divide by 9.

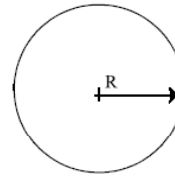

### Oval Area

Area (square feet) =  $\frac{1}{2}$  Length "a" (feet) x  $\frac{1}{2}$  Length "b" (feet) x 3.14.

To change to square yards, divide by 9.

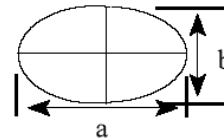

### Triangular Area

Area (square feet) =  $\frac{1}{2}$  Base (feet) x Height (feet)

To change to square yards, divide by 9.

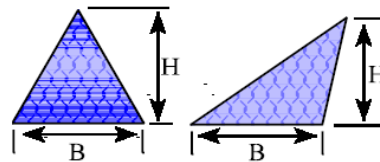

## Formula for geometric figures

### Perimeter formula

$$\text{Square} = 4 * \text{side}$$

$$\text{Rectangle} = 2 * (\text{length} + \text{width})$$

$$\text{Parallelogram} = 2 * (\text{side1} + \text{side2})$$

$$\text{Triangle} = \text{side1} + \text{side2} + \text{side3}$$

$$\text{Circle} = 2 * \text{pi} * \text{radius}$$

### Area formula

$$\text{Square} = \text{side}^2$$

$$\text{Rectangle} = \text{length} * \text{width}$$

$$\text{Triangle} = \text{base} * \text{height} / 2$$

$$\text{Circle} = \text{pi} * \text{radius}^2$$

$$\text{Cone (surface)} = \text{pi} * \text{radius} * \text{side}$$

### Volume formula

$$\text{Cube} = \text{side}^3$$

$$\text{Rectangular Prism} = \text{side1} * \text{side2} * \text{side3}$$

$$\text{Cone} = (1/3) * \text{pi} * \text{radius}^2 * \text{height}$$

$$\text{Pyramid} = (1/3) * (\text{base area}) * \text{height}$$