

# EIU in the Rat Promotes the Potential of Syngeneic Retinal Cells Injected into the Vitreous Cavity to Induce PVR

Francine F. Behar-Cohen,<sup>1,2</sup> Brigitte Thillaye-Goldenberg,<sup>2</sup> Thérèse de Bizemont,<sup>2</sup> Michelle Savoldelli,<sup>1</sup> Dominique Chauvaud,<sup>1,2</sup> and Yvonne de Kozak<sup>2</sup>

**PURPOSE.** To determine whether syngeneic retinal cells injected in the vitreous cavity of the rat are able to initiate a proliferative process and whether the ocular inflammation induced in rats by lipopolysaccharide (LPS) promotes this proliferative vitreoretinopathy (PVR).

**METHODS.** Primary cultured differentiated retinal Müller glial (RMG) and retinal pigmented epithelial (RPE) cells isolated from 8 to 12 postnatal Lewis rats were injected into the vitreous cavity of 8- to 10-week-old Lewis rats ( $10^5$  cells/eye in 2  $\mu$ l sterile saline), with or without the systemic injection of 150  $\mu$ g LPS to cause endotoxin-induced uveitis (EIU). Control groups received an intravitreal injection of 2  $\mu$ l saline. At 5, 15, and 28 days after cell injections, PVR was clinically quantified, and immunohistochemistry for OX42, ED1, vimentin (VIM), glial fibrillary acidic protein (GFAP), and cytokeratin was performed.

**RESULTS.** The injection of RMG cells, alone or in combination with RPE cells, induced the preretinal proliferation of a GFAP-positive tissue, that was enhanced by the systemic injection of LPS. Indeed, when EIU was induced at the time of RMG cell injection into the vitreous cavity, the proliferation led to retinal folds and localized tractional detachments. In contrast, PVR enhanced the infiltration of inflammatory cells in the anterior segment of the eye.

**CONCLUSIONS.** In the rat, syngeneic retinal cells of glial origin induce PVR that is enhanced by the coinduction of EIU. In return, vitreoretinal glial proliferation enhanced the intensity and duration of EIU. (*Invest Ophthalmol Vis Sci.* 2000;41:3915-3924)

**P**roliferative vitreoretinopathy (PVR) remains the major cause of failure in the surgical treatment of retinal detachment. It results from the migration and proliferation of cells of different origins, among which retinal pigment epithelial (RPE) cells and retinal Müller glial (RMG) cells play an important role. These cells undergo fibroblastic transdifferentiation to form fibrocellular membranes onto both surfaces of the neuroretina. This is followed by contraction of the cellular membranes, extracellular collagen production, and formation of fixed folds of the retina.<sup>1-5</sup> Because the very early phases of PVR do not have a clinical expression in humans, the different cell types that may be involved in the process and the extent of the blood-retinal barrier breakdown are difficult to study.<sup>6</sup> At the time when membranes can be dissected for immunohistochemical studies, cells have partially lost their differentiation characteristics, and the inflammatory mediators could be different from those expressed in the early phases of PVR. Inflammation that increases the release of chemotactic and mitogenic factors stimulates the proliferation.<sup>7</sup> Inflammatory cytokines are involved in PVR models in rabbits,<sup>8</sup> and interleukin (IL)-6,

tumor necrosis factor (TNF), interferon (IFN)- $\gamma$ , and, to a lesser extent, IL-1 $\alpha$  and -1 $\beta$  have been identified in epiretinal membranes from human eyes with PVR. Moreover, products of oxidative reactions, probably originating from activated phagocytes and RPE cells, have been detected in the vitreous of patients operated on for PVR.<sup>10</sup> The role of IL-1 $\beta$  has been experimentally demonstrated in the development of epiretinal membranes in the presence of retinal holes. Indeed, IL-1 $\beta$  induces aberrant extracellular matrix remodeling that results in the proliferative process.<sup>11</sup> Cultured human RPE cells constitutively express cytokines, such as IL-1, IL-6, IL-8, and transforming growth factor (TGF)- $\beta$ , that are upregulated when the cells are exposed to a medium of lipopolysaccharide (LPS)-stimulated monocytes. This shows that activated monocytes present when the external hemoretinal barrier is disrupted, produce stimulating factors, among which IL-1 and TNF seem to be the more potent in inducing cytokine expression in human RPE cells in vitro.<sup>12</sup>

Endotoxin-induced uveitis (EIU) in the rat is a model of self-limited inflammation involving both the anterior and the posterior segment of the eye.<sup>13-15</sup> Cytokines such as IL-1, IL-6, IL-8, TNF $\alpha$ , and IFN $\gamma$ , synthesized both by activated resident cells and infiltrating cells, are implicated in the inflammatory cascade of events taking place in EIU.<sup>16-19</sup> The inducible nitric oxide synthase (NOSII) is also expressed during EIU in infiltrating cells and RMG cells,<sup>19,20</sup> and analogues of arginine more specific for the NOSII isoform have an anti-inflammatory effect.<sup>21-23</sup> In the present study, we injected syngeneic differentiated RPE and/or RMG cells in the vitreous of rat eyes with EIU

From the <sup>1</sup>Department of Ophthalmology of Hôtel-Dieu of Paris Hospital; and <sup>2</sup>Institut National de la Santé et de la Recherche Médicale, Paris, France.

Submitted for publication October 21, 1999; revised March 29 and June 23, 2000; accepted July 21, 2000.

Commercial relationships policy: N.

Corresponding author: Francine F. Behar-Cohen, Department of Ophthalmology of Hôtel-Dieu of Paris Hospital, 1, Place du Parvis Notre-Dame, 75004 Paris, France. beharcohen@aol.com

to answer the following questions: Do syngeneic RPE or RMG cells injected separately into the vitreous cavity initiate a proliferative process, or do they have to be injected in combination? Does the ocular inflammation induced in rats by LPS promote the proliferation of syngeneic RPE and/or RMG cells injected into the vitreous cavity?

## MATERIALS AND METHODS

### Preparation of Retinal Resident Cells

RPE and RMG cells were isolated from Lewis rat retinas on postnatal days 8 through 12, by a method previously described.<sup>24</sup> Briefly, eyeballs from decerebrated young rats were incubated in Dulbecco-modified Eagle's medium (DMEM) containing 0.2% trypsin (Difco, Detroit, MI) and 100 U/ml collagenase type CS-1 (Worthington, Freehold, NJ). For RMG cells, the neural retinas were separated from the lens and vitreous, cut into small fragments, and plated in 100-mm petri dishes in DMEM containing 10% fetal calf serum (FCS). After 3 to 4 days, fragments were removed by extensive rinsing with phosphate-buffered saline (PBS), and the remaining flat cell population (mainly RMG cells)<sup>24</sup> were refed with DMEM. RMG cells grew rapidly. For RPE cells, pigment epithelium sheets were gently dissociated after rinsing with PBS containing 0.02% EDTA and 0.05% trypsin and the cells seeded as dispersed suspensions in DMEM containing 10% FCS. The purity of cultures was controlled by immunocytochemical staining.<sup>24</sup> Briefly, cells on coverslips were incubated with the following antibodies: polyclonal antibody anti-CRALBP, a marker specific for RPE cells; polyclonal antibody anti-GS, a marker specific for RMG cells; monoclonal antibody OX42 (antiC3b antigen and a marker for macrophages subsets including microglia); and polyclonal antibody anti-vWF, a marker for vascular endothelial cells. RMG and RPE cells were frozen as primary cultures and then were defrosted and suspended in DMEM, centrifuged at 1000 rpm for 10 minutes, and injected into the vitreous at a concentration of  $10^5$  cells in  $2 \mu\text{l}$  in sterile pyrogen-free 0.9% NaCl. Cell viability was controlled by trypan blue counting before injection. After defrosting, an average of 17% of RMG cells and 20% of RPE cells observed were dead.

Dead RPE and RMG cells were injected into the vitreous cavity of four eyes of four rats that received a systemic injection of LPS as a control group. Dead cells were obtained by UV irradiation, and cell viability was controlled by trypan blue counting. RMG cells were more resistant to irradiation than RPE cells. A 15-minute irradiation killed 90% of RPE cells, whereas a 4-hour irradiation was necessary to kill 90% of the RMG cells.

### Experimental Protocol

**Induction of EIU.** Inbred Lewis rats, 8 to 10 weeks old (Pierre Ravaut, Institut National de la Recherche Agronomique, Nouzilly, France) were injected in the right foot pad with LPS from *Salmonella typhimurium* (Sigma, St. Louis, MO) at  $150 \mu\text{g}$  per rat in a volume of  $150 \mu\text{l}$  sterile pyrogen-free saline.<sup>13,25,26</sup> The experiments were conducted in accordance with the ARVO Statement for the Use of Animals in Ophthalmic and Vision Research.

**Intravitreal Injection of Retinal Cells.** Before intravitreal injection, rats were anesthetized with intraperitoneal in-

jection of pentobarbital (40 mg/kg Nembutal; Abbot, Saint-Remy sur Avre, France), and the pupil was dilated with 1 drop of tropicamide (Mydriaticum; Chibret, Clermont Ferrand, France). Injections ( $2 \mu\text{l}$ ) were performed using a sterile Hamilton syringe (Poly-Labo, Paris, France) and 30-gauge disposable needles (Microlance3; Becton Dickinson, Madrid, Spain) under an operating microscope. A coverslip was adapted on the corneal surface to control the fundus during the injection. Pictures of the fundus were obtained by using a retinograph for small animals (Kowa Genesis; Luneau, Chartres, France) immediately after the cell injections. Any bleeding or a lens touch observed at the end of the injection excluded the rat from the protocol.

Rats (four eyes per group) received injections of RPE cells, RMG cells, a mixture of RPE and RMG cells (RPE+RMG;  $10^5$  cells in  $2 \mu\text{l}$  sterile pyrogen-free saline 0.9%), or saline. These four types of intravitreal injections were administered to rats that were or were not stimulated by the systemic injection of LPS at the time of the ocular injections. Therefore, one group of rats received both the intravitreal injections and the systemic injection of LPS, whereas the other received only the intravitreal injections.

To study the early stages of proliferation, eight rats with eyes injected with RPE+RMG and stimulated with LPS were killed at day 5 and excised eyes examined by either classic histology (four eyes) or immunohistochemistry (four eyes). At further stages (15 and 28 days) EIU-affected animals (four eyes per group) injected with RPE, RMG, RPE+RMG, or saline were killed for immunohistochemistry.

### Follow-up

**Clinical Observation.** Animals were examined daily by biomicroscopy and indirect ophthalmoscopy. Retinophotographs were taken after the injection and at 5, 15, and 28 days. The proliferative response was evaluated according to the following grade scale, as shown on fundus pictures in Figure 1: 0, no proliferative response; 1, intravitreal proliferation; 2, preretinal membrane formation with retinal folds; 3, white dense membrane covering the retina with retinal folds, localized retinal detachments, with or without localized posterior capsular cataract. After the injection of the cells, a vitreal Tyndall effect was observed in the entire vitreous cavity, suggesting that the injected cells spread throughout the vitreous cavity and did not stay at the injection site, as was described with injections in the rabbit vitreous.

In one experiment, at 15 days after the injection into the vitreous of the different cell types, the eyes (four per group) were enucleated for dissection under a binocular microscope. The ocular globes were cut pre-equatorially and photographed to show the gross aspect of the retina in situ (Fig. 3).

To assess the severity of uveitis, rats were examined at 24 hours and 4 and 6 days after LPS injection. The severity of EIU was graded from 0 to 4 by a masked investigator as follows: 0, no inflammatory reaction; 1, discrete dilation of the iris and conjunctival vessels; 2, moderate dilation of the iris and conjunctival vessels; 3, intense iridal hyperemia with flare in the anterior chamber; 4, same clinical signs as grade 3 plus the presence of fibrinous exudate in the pupillary area with intense flare in the anterior chamber.<sup>20</sup> The EIU grade of rats injected in the vitreous with RMG or saline was compared using the nonparametric Mann-Whitney test.

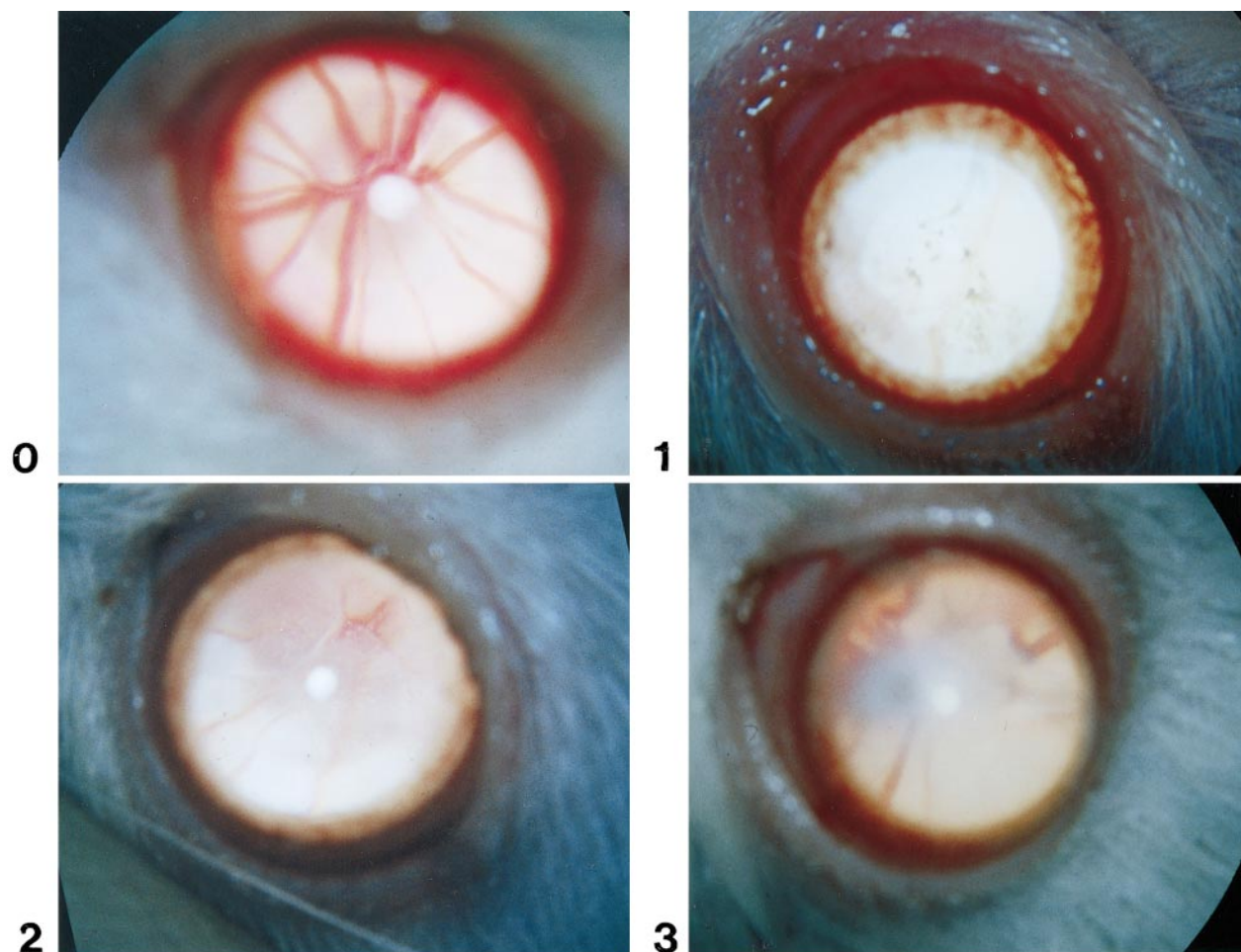

**FIGURE 1.** Retinophotographies showing the proliferation scale: 0, no proliferative response; 1, intravitreal proliferation; 2, preretinal membrane formation with retinal folds; and 3, *white*, dense membrane covering the retina with retinal folds, localized retinal detachments, with or without localized posterior capsular cataract.

**Histopathologic Examination.** At the time of death, 5, 15, and 28 days after the cell injections with or without systemic LPS injection, rats were anesthetized with pentobarbital (40 mg/kg Nembutal, Abbot) and perfused with 2% paraformaldehyde. Eyes were enucleated and postfixed for 1 hour in 2% paraformaldehyde at room temperature, rinsed in 5% sucrose for 5 hours at 4°C, and then incised in the sclera, incubated overnight in 15% sucrose at 4°C, and stored at -20°C. The eyes were then included in optimal cutting temperature (OCT; Tissue-Tek; Miles, Elkhart, IN) and 10- $\mu$ m frozen sections were mounted on gelatin-covered slides to perform immunohistochemical analysis.

### Immunohistochemistry

**OX-42 and ED1.** OX-42 antibody (anti-C3b receptor) was used as a marker for microglia, activated macrophages, dendritic cells, and polymorphonuclear leukocytes and ED1 antibody as a marker for monocytes, macrophages, and some dendritic subpopulations.<sup>14</sup> Sections were washed with PBS, rinsed, incubated for 1 hour at 37°C with PBS containing 5% skimmed milk, and then incubated with either monoclonal OX-42 antibody (anti-C3b receptor) or monoclonal ED1 antibody (Serotec, Oxford, UK), each diluted 1:100 in PBS 1% skimmed milk. After they were washed in PBS, sections were

incubated with biotinylated sheep anti-mouse IgG (1:10 in PBS-1% skimmed milk) and then with fluorescein isothiocyanate (FITC)-conjugated streptavidin (1:100 in PBS-1% skimmed milk), for 1 hour at room temperature. After another washing, they were secured with coverslips. Results of control experiments using rabbit preimmune serum or omitting the first antibody were negative (data not shown).

**GFAP, Vimentin, and Cytokeratin.** Mouse monoclonal anti-vimentin (VIM; Sigma) is a marker of one of the five groups of cytoskeletal intermediate filaments, and mouse monoclonal anti-pan epithelial cytokeratin (CytoK; Boehringer-Mannheim, Mannheim, Germany) is an antibody that reacts with an epitope common to all cytokeratins,<sup>1-19</sup> found in all epithelia. Proliferating RPE were more specifically identified by the cytokeratin 18 antibody (Zymed, San Francisco CA).<sup>27</sup> Each antibody was used at a dilution of 1:50 in PBS-1% skimmed milk, except anti-cytokeratin 18, which was used at 1:10. The rabbit polyclonal antibody anti-glial fibrillary acidic protein (GFAP; Dako, Carpinteria, CA), directed at GFAP was used diluted at 1:100. After a washing, sections were incubated for 1 hour with biotinylated sheep anti-mouse IgG (1:50 in PBS-1% skimmed milk) or with biotinylated sheep anti-rabbit IgG (1:50 in PBS-1% skimmed milk) and then for 1 hour with fluorescein-

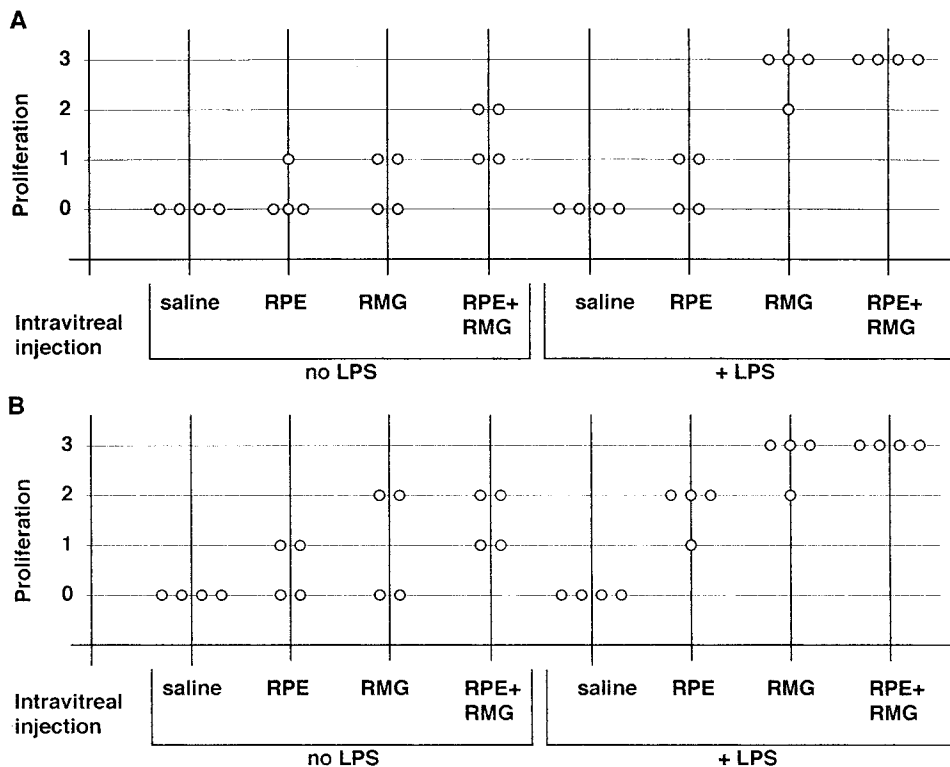

**FIGURE 2.** Proliferation grade. Results of clinical examinations at 15 (A) and 28 (B) days after intravitreal injections.

conjugated streptavidin (1:50 in PBS-1% skimmed milk; Amersham Life Science, Little Chalfont, UK). Sections were observed using a photomicroscope (FXA; Nikon, Tokyo, Japan).

## RESULTS

### Clinical Examination

**EIU Grade.** The intravitreal injection of RMG cells enhanced and prolonged the severity of EIU. At 24 hours after LPS injection, the EIU grade of rats that received the intravitreal injection of RMG cells was  $3.12 \pm 1.25$  ( $n = 8$ ), compared with  $1.12 \pm 0.35$  ( $n = 8$ ) for rats that were injected with saline ( $P = 0.003$ ). At 4 days after LPS injection, the EIU grade was  $2.25 \pm 0.46$  ( $n = 8$ ) in the group that received the RMG injection compared with  $1.12 \pm 0.35$  in the group that received saline ( $P = 0.001$ ). At 6 days, the EIU grade was still  $2.0 \pm 0.44$  ( $n = 6$ ) in the group of rats injected with RMG cells, whereas it was  $0.8 \pm 0.4$  ( $n = 6$ ) in the saline-injected group ( $P = 0.03$ ).

**PVR 15 Days after the Injection of Retinal Cells.** Clinically, no anterior inflammation was detected at 15 days in any eyes injected with RMG or RPE cells, and in the control group of rats that received only saline injected into the vitreous cavity with or without LPS, findings in the fundus examination were normal (Fig. 2A).

In the group of rats that received retinal cells without LPS stimulation, a limited intravitreal proliferation arising from the retina could be observed but no retinal detachment (Fig. 2). Among eyes injected only with RPE cells, two eyes had no proliferative response, and two eyes had mainly an intravitreal fibrocellular formation arising from the optic nerve head. On the contrary, in the eyes injected with RMG cells with or without RPE cells, the ocular inflammation induced by LPS enhanced the level of membrane formation. Indeed, prolifera-

tion was observed in 10 of 12 eyes (Fig. 2): A grade 3 PUR was observed in 3 of 4 eyes when RMG cells were injected alone and in all eyes when RPE+RMG were injected. At PVR grade 3, a white, dense neoformed tissue extended into the vitreous and onto the retinal surface, altering the visibility of the retina and the retinal vessels, which appeared dilated at the periphery of the retina (Fig. 1). This aspect was confirmed by the direct examination of the retina at 15 days after the injection of RPE+RMG cells and LPS, during the dissection (Fig. 3). Multiple folds and localized detachment were observed, particularly at the posterior pole (Fig. 3B), in comparison with the retina of the rat that received only the saline injection (Fig. 3A).

Therefore, the strongest proliferative process was induced by the injection of RMG or the coinjection of RMG and RPE cells in EIU-affected eyes.

**PVR 28 Days after Injection of Cells.** No proliferation was observed in any eyes that received saline injection in the vitreous, with or without LPS injection (grade 0; Fig. 2B).

When no EIU was induced, no retinal detachment (grade 3) was ever observed, and no proliferative response (grade 0) was noted in 4 of 12 injected eyes. When RMG or RMG+RPE were injected, a limited intravitreal and prepapillary proliferation of grade 1 or 2 could be observed in 50% of the eyes. When the injected cells were only RPE, a prepapillary membrane was observed in one eye only. Therefore, RMG seems more potent than RPE to stimulate an intravitreal and preretinal proliferation in the normal rat eye.

When EIU was induced, the clinical observation was different. In the eyes that received either RMG alone or the coinjection of RMG and RPE cells, the progressive intravitreal and preretinal proliferation led to localized folds and localized retinal detachments in all cases. In some eyes, the retina could hardly be examined because of the dense membrane formation

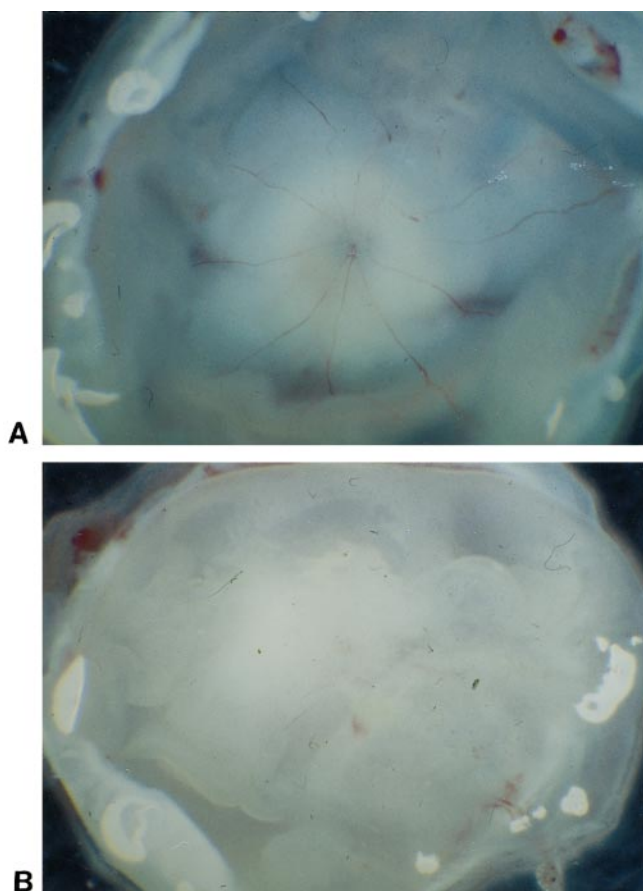

**FIGURE 3.** Pictures of the retina in situ during dissection of ocular globes. (A) Retina of a rat 15 days after systemic injection of LPS and saline (2  $\mu$ l) intravitreal injection, showing a normal flat retina. (B) Retina of a rat 15 days after systemic injection of LPS and RPE+RMG intravitreal injection, showing a *white* dense membrane at the retinal surface. The retina seemed folded, and retinal vessels, only visible at the periphery, were dilated and tortuous.

developing into the vitreous. Moreover, a localized subcapsular posterior cataract occasionally appeared (3 of 14 eyes, PVR grade 4) at a late stage of the proliferation (>15 days). This cataract seemed to originate from proliferating cells growing on the anterior retina that invaded the posterior capsule. This phenomenon was identified when eyes were dissected under a microscope. When dead RMG+RPE cells were injected into the vitreous of rats stimulated by systemic injection of LPS, no clinical or histologic proliferation was observed at any time of examination (from day 1 to 28; data not shown).

#### Histologic and Immunohistochemical Analysis of Eyes 5 Days after RPE+RMG Injections and Systemic Stimulation with LPS

As shown in Figure 4, at this early time point, there were already numerous cells at the retinal surface in an extracellular matrix that could be fibrin and collagen fibrils (Figs. 4A, 4D). Cells at the retinal surface had established connections with the inner retina (Fig. 4B), and in some areas true ruptures of the inner limiting membrane (ILM) could be observed (Fig. 4E). Numerous cell phenotypes constituting these early membranes were demonstrated on semithin sections (Fig. 4D) and by

immunohistochemistry. Indeed, at that stage, ED1- (Fig. 4G) and GFAP-positive cells (Fig. 4F) were found in the vitreous and over the retinal surface. Pan anti-cytokeratin identified no RPE over the ILM and in the vitreous but labeled the resident RPE (Fig. 4H). This finding suggests that injected RPE cells had probably already undergone apoptosis at that time. Anti-cytokeratin 18 antibody confirmed the absence of RPE cells in the vitreous and labeled the resident RPE, suggesting that they were in a proliferative state. Giant cells could correspond to phagocytic macrophages' having ingested RPE (Fig. 4B). This finding is currently under investigation in the very early days of this PVR model.

#### Immunohistochemical Analysis of Eyes 15 and 28 Days after Injections

At 15 days, in control rats with EIU that had saline injected into the vitreous, rare ED1-positive (Fig. 5A) and OX42-positive (Fig. 5B) cells were still present in the iris and ciliary body, and some OX42-positive cells were found in the retina (Fig. 5E). In these rats, positive staining of retinal RMG cells with anti-GFAP and anti-VIM antibodies was observed, but no membrane formation in the vitreous or at the retinal surface (Figs. 5C, 5D). In control rat eyes that received no injection of cells or LPS, no anti-GFAP and no anti-VIM staining was observed (results not shown), suggesting that LPS induced an activation of retinal glial cells that lasted at least 15 days after the clinical uveitis. In contrast, in control eyes of animals injected in the footpad with LPS only, no inflammatory cells could be detected at that time (data not shown).

When RMG and RPE cells were injected into the vitreous of rats that did not receive LPS, positive staining of RMG cells with GFAP and VIM was observed throughout the retina, but no membrane formation, retinal proliferation, or retinal folds were observed (not shown). When RMG cells, with or without RPE cells, were injected into EIU-affected eyes, the number of OX42- and ED1-positive cells observed in the iris and ciliary body (Figs. 6A, 6B, 7A, 7B) seemed to be increased compared with EIU-affected eyes that received only saline intravitreal injection. The intravitreal injection of retinal cells prolonged the cell infiltration in the anterior segment of eyes with EIU, but not in the retina (Fig. 7E compared with 6E).

Immunohistochemistry confirmed the clinical observation of preretinal proliferation that was positively labeled by anti-GFAP and anti-VIM glial antibodies (Figs. 6, 7), covering the whole retinal surface (Figs. 6C, 7C) and causing in some cases localized retinal detachment (Figs. 7D, 7E, 7F) mostly in the case of RMG injection. At the ILM level, the GFAP-positive proliferative process seemed to originate from resident glial cells that looked disorganized (Fig. 7C).

In rats with EIU that were injected with RMG+RPE, strong GFAP and VIM positivity was detected in all resident RMG cells located either in continuity with or at a distance from the membranes, throughout their length. The vitreal end feet of RMG cells seemed disorganized. Cytokeratin labeling was dense in the RPE layer (Figs. 5F, 6F), in comparison with the staining found in the saline+LPS-injected eyes, suggesting that the resident RPE cells could have proliferated, even in places where no retinal detachment was observed (Fig. 6F). At this time point, the injected cells could no longer be observed in the vitreous or at the ILM surface. The same observations were made in the group of rats injected with RMG and RPE cells and stimulated with LPS. However, in this case, the intravitreal

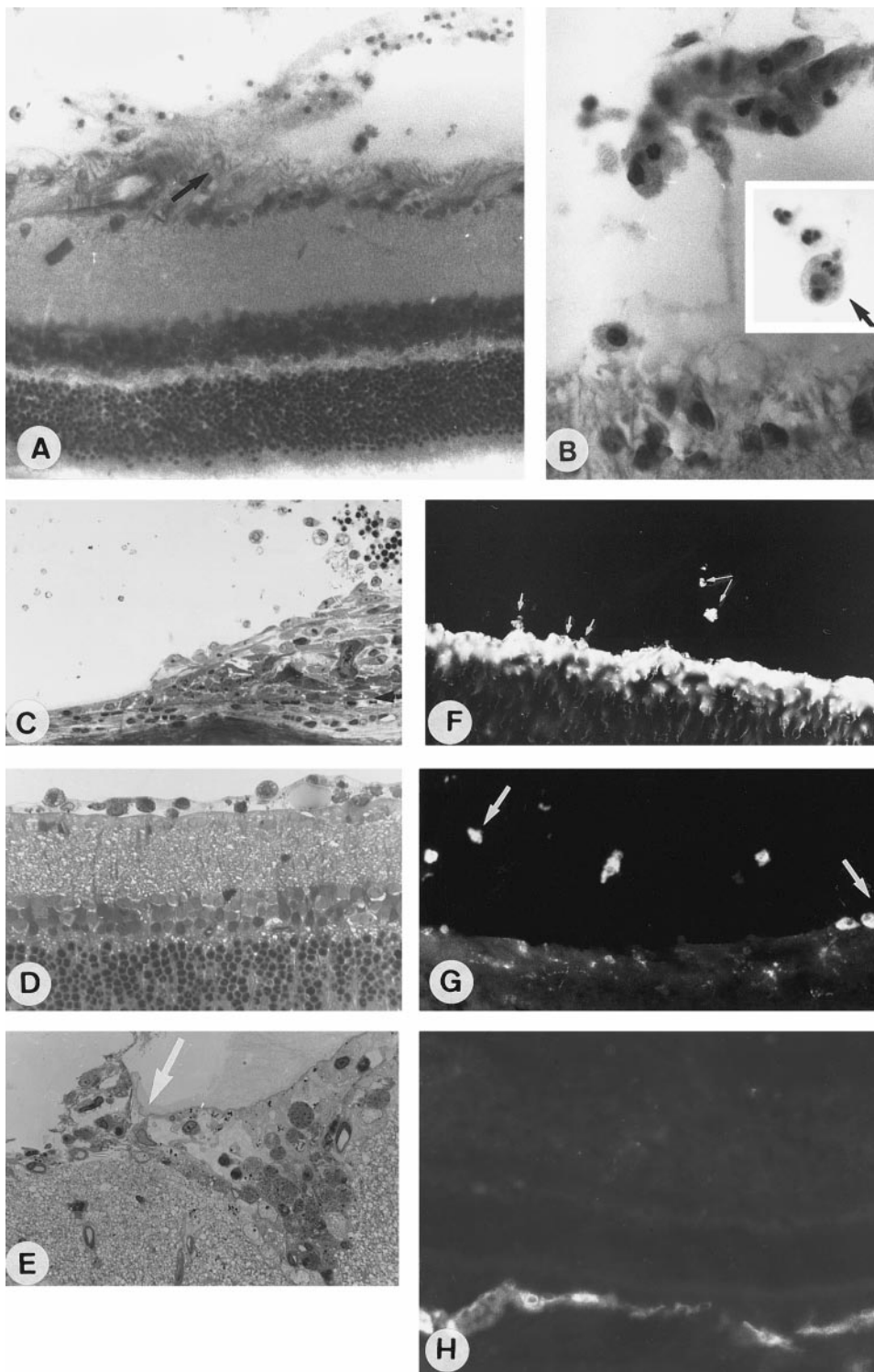
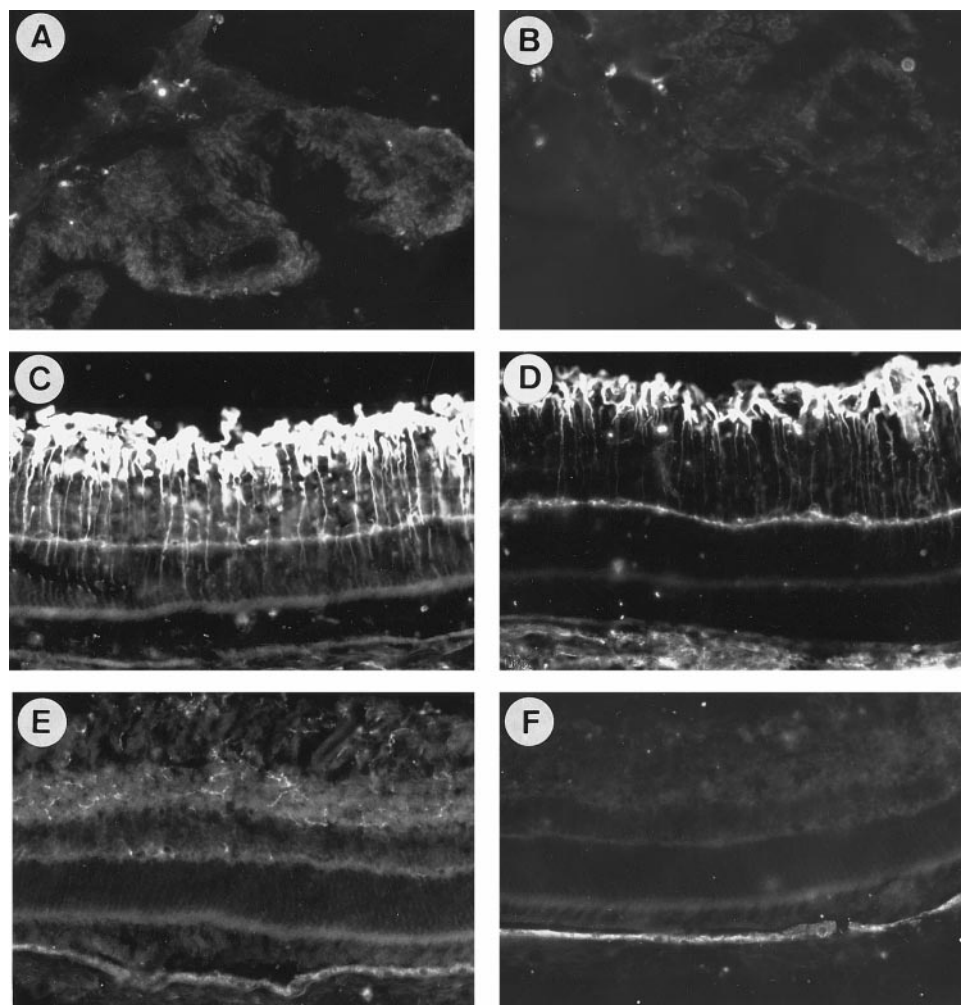

**FIGURE 4.** Histologic and immunohistochemical analysis of eyes 5 days after RPE+RMG injections and systemic stimulation with LPS. (A) Histologic section of the retina, showing a membrane in formation at the retinal surface. (B) Higher magnification, showing numerous cell phenotypes and a macrophage ingesting fragmented nuclei cells (*arrow*). (C) Retinal epithelium at a site where multiple layers can be observed growing on a preserved Bruch membrane (*arrows*). (D) Semithin section of inner retina showing a membrane in formation at the retinal surface. (E) Rupture of the ILM (*arrow*). (F) GFAP immunohistochemistry showing irregularities of the retinal surface and numerous positive cells over the retina and in the vitreous (*arrows*). (G) ED1 immunohistochemistry showing numerous positive cells in the vitreous and over the retina. (H) Pancytokeratin immunohistochemistry showing no positive cells labeled in the vitreous or over the retina and a thick staining of the resident RPE layer. Magnification, (A)  $\times 165$ ; (B)  $\times 350$ .

proliferation was so dense in some cases (as shown on direct examination of the dissected retina (Fig. 3) that it was very difficult to obtain sections without damaging the retina. In the eyes in which the retina could be observed, the glial fibrous membrane on the retinal surface also led to tractional retinal detachments. The same observations were made at 28 days after the injections, demonstrating that the proliferative process took place rapidly after cell injections and then did not decrease in the course of time.

## DISCUSSION

These experiments were designed to evaluate the effect of the injection of syngeneic retinal cells of epithelial and glial origin into the vitreous cavity of rats with an acute ocular inflammation induced by systemic LPS injection. PVR is thought to be due to the proliferation and activation of mostly RPE and glial retinal cells located in the vitreous cavity when a retinal tear has occurred.<sup>7</sup> However, several critical events could play a



**FIGURE 5.** Immunohistochemistry 15 days after systemic LPS injection and saline intravitreal injection. Ciliary body: (A) ED1 and (B) OX-42 staining. Very few ED1- and OX42-positive cells were still present in the iris-ciliary body at 15 days after LPS injection. Retina: (C) GFAP staining, showing activated RMG cells; (D) VIM staining; (E) OX-42 staining, showing microglia in the retina but no OX-42-positive infiltrating cells; and (F) pancytokeratin staining of the resident RPE cells.

role in the development of PVR: the number of cells in the vitreous cavity, the cell types, the interaction between cells located in the vitreous and the resident retinal cells, the presence of diffusible mediators, and a blood-ocular barrier breakdown. In experimental models of retinal detachments, all non-neuronal cell types of the detached and the nondetached retina proliferate at a maximal rate 3 to 4 days after the onset of the detachment.<sup>28</sup> Whether the proliferative messages originate from the detached retina, the RPE, the dislocated retinal cells in the vitreous, or the inflammatory cells or in relation to the blood-ocular barrier breakdown<sup>29</sup> is not known.

Our results show that the injection of RMG cells into the vitreous of LPS-stimulated rats, alone or in combination with RPE cells, induces the formation of glial tissue at the retinal surface, which is responsible for localized retinal detachments.

EIU is a self-limited inflammation of both segments of the eye in which the cytokines expressed in the eye tissues and media are very similar to those detected in animal models of PVR and in human PVR.<sup>9,11,15,18</sup> Moreover, an activation of retinal cells by the systemic injection of LPS is observed as is the case when the retina is detached.<sup>3,4,5,28-32</sup> The syngeneic retinal cells injected into the vitreous cavity of rat eyes with EIU were thus in a biologic environment that was close to that of the early phase of retinal detachment.

EIU clearly increased the density of membranes induced by the injection of retinal cells, which could be related to an

activation of the resident RMG cells that increases their potential to proliferate and synthesize an extracellular matrix. Indeed, although no labeling was detected in normal control retina, in rats with EIU alone or combined with the injection of saline in the vitreous, positive GFAP staining of resident RMG cells was observed up to 16 days after LPS injection (not shown), but no membrane formation was observed. It is not clear whether the proliferating membranes originated from the injected cells or from an activation of RMG resident cells. But, the activation of the RMG cells of the whole retina, the irregularities of the end feet of the Müller cells at the ILM, and the presence of numerous astrocytes in this region are arguments in favor of this latest hypothesis. Whether cells present in the PVR membranes could at least partially originate from migrating retinal glial cells is another possibility. Indeed, systemic injection of LPS has been shown to induce a massive invasion of the retina by OX42+macrophage-microglial cells, which decreases from 72 hours to return to normal at 14 days.<sup>33</sup> In contrast, in EIU-affected rats with proliferative membranes, a cellular inflammation is still observed 14 to 15 days after LPS-injection, which indicates a long-lasting inflammatory process. Inflammation induced by EIU enhanced the proliferative process that in return enhanced and prolonged ocular cell infiltration.

The first event that was observed after RMG or RPE+RMG injections, at day 5, was disruption and irregularities of the

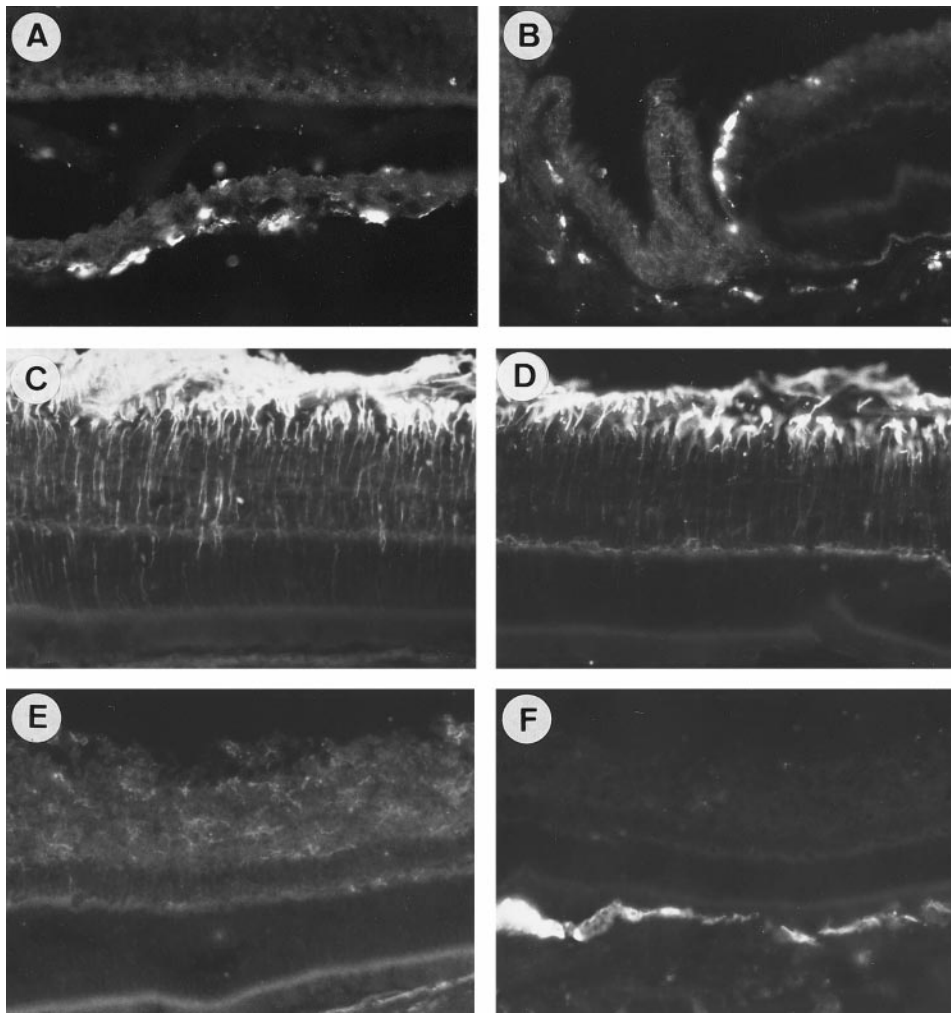

**FIGURE 6.** Immunohistochemistry 15 days after systemic LPS injection and RPE+RMG intravitreal injection. Ciliary body: (A) ED1 and (B) OX-42 staining showed numerous infiltrating cells still present in the anterior segment at 15 days after LPS and cell injections. Retina: (C) GFAP staining showing a disorganized inner retina and glial proliferation at the retinal surface; (D) VIM staining of the neoformed tissue; (E) OX-42 labeling of the microglia but showing no infiltrating cells; and (F) pancytokeratin, staining showing a thick RPE layer in a proliferative state, as was shown by anti-cytokeratin 18 labeling (not shown).

ILM, disorganization of RMG cell end feet, in addition to intraretinal GFAP labeling, followed by the formation of GFAP and VIM-positive tissue, leading to tractional detachments. It has been shown recently that RMG cells injected in the rabbit vitreous induce antigenic changes of RMG into the retina itself, leading to the expression of contractile protein. Dislocated RMG cells could therefore participate in the activation of intraretinal RMG cells.<sup>34</sup> It is of interest that RPE was the less potent cell type for the induction of a preretinal or intraretinal proliferation. This could be explained by the relatively low amount of injected cells, because the proliferative critical mass of cells for the rabbit PVR is 250,000,<sup>35,36</sup> but no critical mass has been determined for the rat; by rapid death of RPE cells as soon as 5 days after injection, as shown by the absence of proliferative RPE cells in early cellular membranes, or in the vitreous. TGF- $\beta$ , which is expressed during EIU, has been shown to have a proapoptotic effect on cultured RPE cells in vitro, whereas no apoptosis could be detected in glial cells.<sup>37</sup> This suggests that in our experimental conditions, apoptosis of the injected retinal cells could occur early after their intravitreal injection, whereas glial proliferation from the activated resident RMG cells would persist for longer periods. This hypothesis is currently under examination. However, RPE cells, present early, seem to play the role of starter in the proliferative process, because the coinjection of RMG+RPE

was more potent than RMG cells alone. The synthesis of cytokines by RPE cells and the release of growth factor by the dying cells could be involved in this starter effect. Retinal cells in contact with the vitreous show strong phenotypic changes,<sup>38</sup> and stimulated RPE and glial cells themselves synthesize cytokines that act in an autocrine, paracrine, or intracrine manner. In return, after RMG cell injection, the RPE layer from the host retina was much thicker, as shown by cytokeratin labeling, even in the absence of retinal detachment. This was further confirmed by the presence of RPE cells in the retinal folds.

The type of proliferation observed in our model was similar to that induced in the rabbit by RMG cell intravitreal injection<sup>39</sup> and by dispase intravitreal injection.<sup>40</sup> The prepapillary injection of dispase allowed the formation of proliferative retinopathy with retinal folds and localized traction retinal detachment, which are thought to originate from activation of native cells.<sup>40</sup> However, total retinal detachments did not occur as in other experimental models of PVR that have been developed in the rabbit using injections of heterologous cells or homologous fibroblasts.<sup>41-44</sup> Those models efficiently induce total tractional retinal detachment and could be very effective for therapeutic screening, but they may have a very different pathogenesis than human PVR.

In conclusion, in our experiments EIU enhanced vitreo-retinopathy induced by the injection of syngeneic retinal cells



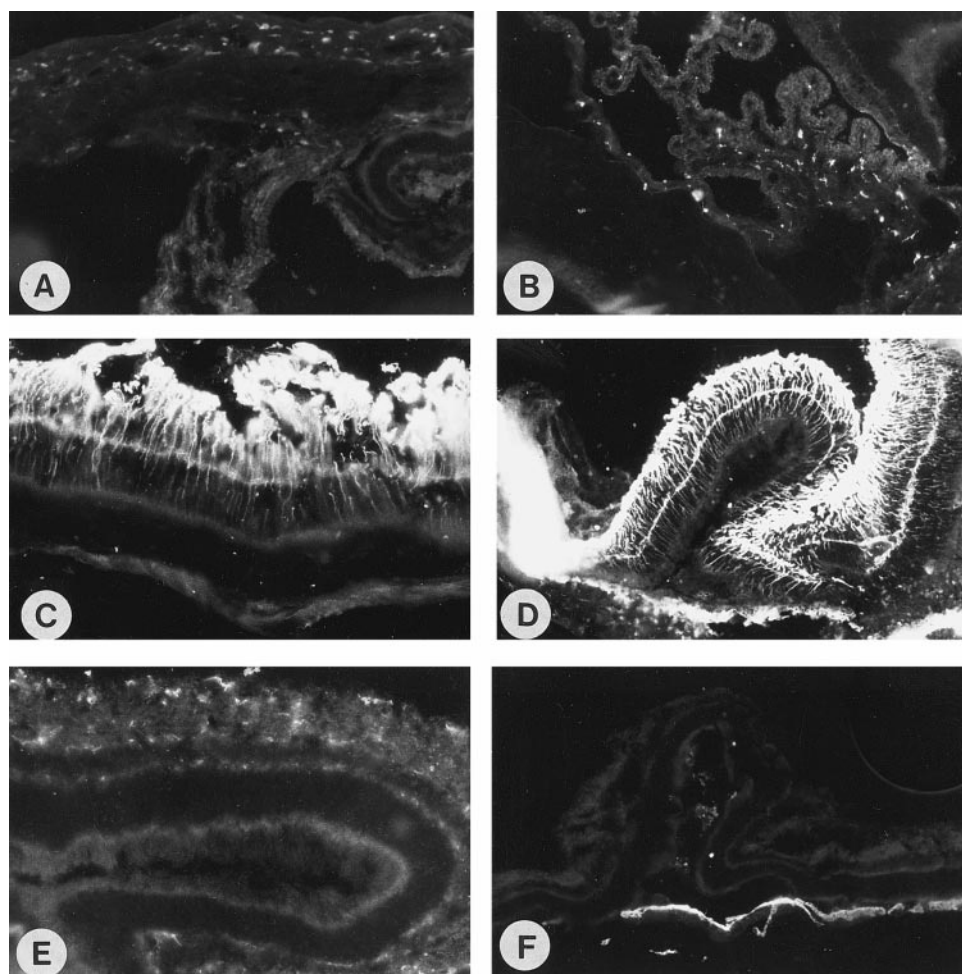

**FIGURE 7.** Immunohistochemistry 15 days after systemic LPS injection and RMG cell intravitreal injection. Ciliary body: (A) ED1 and (B) OX-42 staining showing infiltrating cells still present in the anterior segment at 15 days. Retina: (C) GFAP staining showing marked glial proliferation at the retinal surface; (D) VIM staining showing a localized neuroretinal detachment; (E) OX-42 labeling showing a localized neuroretinal detachment with microglia and very few positive cells at the retinal surface; and (F) pancytokeratin staining at the level of a localized detachment showing a thick RPE and some positive cells in the detached area, corresponding to migrating RPE.

in the vitreous cavity. Correlatively, the injection of retinal cells increased clinical inflammation and cytokine expression in the iris-ciliary body and in the retina, which is also correlated to development of vitreoretinopathy. This PVR model in the rat could be of use in further study of cellular interactions in the vitreous and between the vitreous and the retina and particularly study of the early events occurring at the vitreoretinal interface.

## References

- Machemer R, Laqua H. Pigment epithelium proliferation in retinal detachment (massive periretinal proliferation). *Am J Ophthalmol.* 1975;80:1-23.
- Machemer R, Van Horn D, Aaberg TM. Pigment epithelial proliferation in human retinal detachment with massive periretinal proliferation. *Am J Ophthalmol.* 1978;85:181-191.
- Van Horn DL, Aaberg TM, Machemer R, Fenzi R. Glial cell proliferation in human retinal detachment with massive periretinal proliferation. *Am J Ophthalmol.* 1977;84:383-393.
- Laqua H, Machemer R. Glial cell proliferation in retinal detachment (massive periretinal proliferation). *Am J Ophthalmol.* 1975;80:602-618.
- Newsome DA, Rodrigues MM, Machemer R. Human massive periretinal proliferation: in vitro characteristics of cellular components. *Arch Ophthalmol.* 1981;99:873-880.
- Campochiaro PA, Bryan JA III, Conway BP, Jaccoma EH. Intravitreal chemotactic and mitogenic activity: implication of blood-retinal barrier breakdown. *Arch Ophthalmol.* 1986;104:1685-1687.
- Campochiaro PA. Pathogenic mechanisms in proliferative vitreoretinopathy. *Arch Ophthalmol.* 1997;115:237-241.
- Planck SR, Andresevic J, Chen JC, et al. Expression of growth factor mRNA in rabbit model system *Curr Eye Res.* 1992;11:1031-1039.
- Limb GA, Alam A, Earley O, Green W, Chignell AH, Dumonde DC. Distribution of cytokine protein within epiretinal membranes in proliferative vitreoretinopathy. *Curr Eye Res.* 1994;13:791-798.
- Boker T, Augustin AJ, Spitnas M, Lutz J. Increased lipid peroxide level and myeloperoxidase activity in the vitreous of patients suffering from proliferative vitreoretinopathy. *Graefes Arch Clin Exp Ophthalmol.* 1994;32:652-656.
- Kosnosky W, Li TH, Pakalnis VA, Fox A, Hunt RC. Interleukin 1- $\beta$  changes the expression of metalloproteinases in the vitreous humor and induces membrane formation in eyes containing preexisting retinal holes. *Invest Ophthalmol Vis Sci.* 1994;35:4260-4267.
- Jaffe G, Roberts WL, Wong HL, Yurochko AD, Cianciolo GJ. Monocyte-induced cytokine expression in cultured human retinal pigmented epithelial cells. *Exp Eye Res.* 1995;60:533-543.
- Ruiz-Moreno JM, Thillaye B, de Kozak Y. Retinochoroidal changes in Endotoxin-induced uveitis in the rat. *Ophthalmic Res.* 1992;24:162-168.
- McMenamin PG, Crewe J. Endotoxin-induced uveitis: kinetic and phenotype of the inflammatory cell infiltrate and the response of the resident tissue macrophages and dendritic cells in the iris and ciliary body. *Invest Ophthalmol Vis Sci.* 1995;36:1949-1959.

15. Hoekzema R, Murray PI, Kijlstra A. Cytokines and intraocular inflammation. *Curr Eye Res.* 1990;9:207-211.
16. Hoekzema R, Verhagen C, van Haren M, Kijlstra A. Endotoxin-induced-uveitis in the rat. *Invest Ophthalmol Vis Sci.* 1992;33:532-539.
17. Rosenbaum JT, Angell E. Paradoxical effect of IL-10 in endotoxin-induced uveitis. *J Immunol.* 1995;155:4090-4094.
18. DeVos AF, Hoekzema R, Kijlstra A. Cytokines and uveitis: a review. *Curr Eye Res.* 1992;11:581-597.
19. de Kozak Y, Hicks D, Chatenoud I, Bellot J, Thillaye B, Faure JP. Intraocular TNF in endotoxin-induced-uveitis: in vitro synthesis of TNF by retinal Müller glial and pigmented epithelial cells. *Reg Immunol.* 1994;6:76-80.
20. Jacquemin E, de Kozak Y, Thillaye B, Courtois Y, Goureau O. Expression of inducible nitric oxide synthase in the eye from endotoxin-induced uveitis rats. *Invest Ophthalmol Vis Sci.* 1996;37:1187-1196.
21. Mandai M, Yoshimura N, Yoshida M, Iwaki M, Honda Y. The role of nitric oxide synthase in endotoxin-induced uveitis: effect of N $\omega$ -nitro L-arginine. *Invest Ophthalmol Vis Sci.* 1994;35:3673-3680.
22. Parks DJ, Cheung MK, Chan CC, Roberge F. The role of nitric oxide in uveitis. *Arch Ophthalmol.* 1994;112:544-546.
23. Tilton RG, Chang K, Corbett JA, et al. Endotoxin-induced uveitis in the rat is attenuated by inhibition of nitric oxide production. *Invest Ophthalmol Vis Sci.* 1994;35:3278-3288.
24. De Kozak Y, Naud MC, Bellot J, Faure JP, Hicks D. Differential tumor necrosis factor expression by resident retinal cells from experimental uveitis-susceptible and-resistant rat strains. *J Neuroimmunol.* 1994;55:11-16.
25. Rosenbaum JT, MacDevitt HO, Guss RB, Egbert PR. Endotoxin-induced uveitis in rats as a model for human disease. *Nature.* 1980;286:611-613.
26. De Vos AF, Klaren VNA, Kijlstra A. Expression of multiple cytokines and IL-1RA in the uvea and retina during endotoxin-induced uveitis in the rat. *Invest Ophthalmol Vis Sci.* 1994;35:3873-3883.
27. McKechnie NM, Boulton M, Robey H, Savage FJ, Grierson I. The cytoskeletal elements of human retinal pigment epithelium: in vitro and in vivo. *J Cell Sci.* 1988;91:303-312.
28. Fisher SK, Anderson DH. Cellular effects of detachment on the neural retina and the retinal pigment epithelium. In: Glaser BM, Michels RM, ed. *Retina.* Vol 3. St Louis, MO: CV Mosby; 1989:165-190.
29. Little BC, Ambrose VMG. Blood-aqueous barrier breakdown associated with rhegmatogenous retinal detachment. *Eye.* 1991;5:56-62.
30. Anderson DH, Stern WH, Fisher SK, Erickson PA, Borgula GA. Retinal detachment in the cat: the pigment epithelial-photoreceptor interface. *Invest Ophthalmol Vis Sci.* 1983;24:906-913.
31. Erickson PA, Fiosher SK, Anderson DH, Stern WH, Borgula GH. Retinal detachment in the cat: the outer nuclear outer plexiform layers. *Invest Ophthalmol Vis Sci.* 1983;24:927-942.
32. Fisher SK, Erickson PA, Lewis GP, Anderson DH. Intraretinal proliferation induced by retinal detachment. *Invest Ophthalmol Vis Sci.* 1991;32:1739-1748.
33. Yang P, de Vos A, Kijlstra A. Macrophages in the retina of normal Lewis rats and their dynamics after injection of lipopolysaccharide. *Invest Ophthalmol Vis Sci.* 1996;37:77-85.
34. McGillem G, Dacheux R. Rabbit retinal Müller cells undergo antigenic changes in response to experimentally induced proliferative vitreoretinopathy. *Exp Eye Res.* 1999;68:617-627.
35. Hatchell DL, MacAdoo T, Sheta RT, Bartolome JV. Quantification of cellular proliferation in experimental PVR. *Arch Ophthalmol.* 1988;106:669-672.
36. Fastenberg DM, Diddie KR, Dorey K, Ryan SJ. The role of cellular proliferation in an experimental model of massive preretinal proliferation. *Am J Ophthalmol.* 1982;93:565-572.
37. Esser P, Heimann K, Bartz-Schmidt KU, et al. Apoptosis in proliferative vitreoretinal disorders: possible involvement of TGF- $\beta$ -induced RPE cell apoptosis. *Exp Eye Res.* 1997;65:365-378.
38. Viores S, Campochiaro P, McGehee R, Orman W, Hackett S, Hjelmeland L. Ultra structural and immunocytochemical changes in retinal pigment epithelium, retinal glia, and fibroblasts in vitreous culture. *Invest Ophthalmol Vis Sci.* 1990;31:2529-2545.
39. Peters MA, Burke JM, Clowry M, Abrams GW, Williams GA. Development of traction retinal detachments following intravitreal injections of retinal Muller and pigmented epithelial cells. *Graefes Arch Clin Exp Ophthalmol.* 1986;224:554-563.
40. Frenzel EM, Nely KA, Walsh AW, Cameron JD, Gregerson DS. A new model of proliferative vitreoretinopathy. *Invest Ophthalmol Vis Sci.* 1998;39:2157-2164.
41. Sugita G, Tano Y, Machermer R, Abrams G, Claffin A, Fiorentino G. Intravitreal autotransplantation of fibroblasts. *Am J Ophthalmol.* 1980;89:121-130.
42. Gonvers M, Thresher R. Temporary use of silicone oil in the treatment of proliferative vitreoretinopathy: an experimental study with a new animal model. *Graefes Arch Clin Exp Ophthalmol.* 1983;221:46-53.
43. Chandler DB, Quansah FA, Hida T, Machermer R. A refined experimental model for proliferative vitreoretinopathy. *Graefes Arch Clin Exp Ophthalmol.* 1986;224:20-22, 86-91.
44. Baudoin C, Ettaiche M, Imbert F, Droy-Lefaux MT, Gastaud P, Lapalus P. Inhibition of preretinal proliferation by free radical scavengers in an experimental model of tractional retinal detachment. *Exp Eye Res.* 1994;59:697-706.