

Numerical Analysis of Point Absorber for Wave Energy Conversion in Malaysian Seas

Research
Article

Kang Hooi-Siang^{*,1,2}, Mohd Qisti Hakim Shaharuddin¹, Lee Kee-Quen³, Adelina Steven⁴, Ummul Ghafir Md Arif¹, Nurhaslinda Khaliddin¹, Siow Chee-Loon^{1,2}

¹ Department of Aeronautical, Automotive & Ocean Engineering, Faculty of Mechanical Engineering, Universiti Teknologi Malaysia, 81310 Skudai Johor, Malaysia

² Marine Technology Centre (MTC), Institute for Vehicle System and Engineering (IVeSE), Universiti Teknologi Malaysia, 81310 Skudai Johor, Malaysia

³ Department of Mechanical Precision Engineering, Malaysia-Japan International Institute of Technology (MJIT), Universiti Teknologi Malaysia Kuala Lumpur, 54100 Kuala Lumpur, Malaysia

⁴ School of Naval Architecture and Marine Engineering, University of New Orleans, New Orleans, Louisiana, USA

ARTICLE INFO

ABSTRACT

Article history:

Received 15 March 2017

Received in revised form 22 May 2017

Accepted 24 May 2017

Available online 15 June 2017

Wave energy conversion by using point absorber has recently gained intensive research in renewable energy. However, a majority of research works only focused on the regions with high wave heights, which may not be readily achievable in Malaysian seas condition. As the technology of point absorber facing the concern on less-applicability in low wave height conditions in Malaysia, a numerical modeling to understand the maximum potential power output to be generated by point absorber is now in demand to predict the power capture ability of point absorber in Malaysian waters. In order to complete this research gap, this paper is aiming to determine the sensitivity of different configurations of power take-off system in point absorber and to numerically analyze the potential maximum power output to be generated by the point absorber in Malaysian water, under regular wave motion. The significance of this study leads to a better understanding of the envelope of power output generated by point absorber in Malaysian seas. The methodology is conducted with theoretical modeling of point absorber, developing a numerical model of power take-off system to identify the maximum magnetic flux density of different stator-rotor configuration, and simulating the power output of point absorber in time-domain under regular wave condition based on Malaysia seas data. The results show that power output of point absorber can be increased by a double-sided stator. The envelope of maximum power output to be generated has been identified. This research provides a further understanding of the development of point absorber technologies in Malaysian seas condition.

Keywords:

Point absorber, Numerical analysis,
Wave energy

Copyright © 2017 PENERBIT AKADEMI BARU - All rights reserved

1. Introduction

Harvesting energy from ocean in electricity power generation has been gaining vast interests from the researchers in the development of renewable energy and multiple types of ocean energy conversion methods, such as tidal [1-6], overtopping [7-9], oscillating water column [10-13], ocean currents [14-

*Corresponding author.

E-mail address: kanghs@utm.my

16], ocean thermal energy conversion [17, 18], salinity gradient power [19], and heaving point absorber [20-34] have been investigated. A point absorber is an ocean energy conversion device for harvesting wave energy and converting it into electricity through its power take-off system. A point absorber can either employ a hydraulic system or linear permanent magnet electrical generator to convert electricity [35]. Korde [21] investigated enhancement for power-absorption by point absorber and presented a frequency domain solution for an optimal power absorption in single mode device. A 10 kW direct drive point absorber was developed in [27]. Yeung et al. [22] evaluated technical feasibility and performance of a linear generator in point absorber by mathematically modeling the critical parameters that can affect the efficiency of the design and later physically test the constructed model in a wave tank. Cochet and Yeung [30] further investigated the solution of coupled surge-pitch motion of point absorber and reported that small radius and deeper draft of the outer buoy can exert larger capture width and motion. Tom and Yeung [32] also evaluated the nonlinear relationship between the generator damping and the magnet-coil gap width and they revealed that more than a double increment of the capture widths can be obtained by proper matching these parameters.

As the numerical simulation tools [36, 37] become more comprehensive with respect to the rapid increment of computing power, the cost to develop the point absorber in more complex structural behaviors is now reduced significantly before an expensive model test has been carried out. For instance, wave energy convertor analysis by using Unsteady Reynolds Averaged Navier-Stokes (URANS) simulations were developed in [37] and the peaks of power predicted by URANS are close to the experimental values with a difference in the frequencies at the power peaks was observed. Numerical modeling and optimization of a point absorber were developed in [22, 23]. Further, computational fluid dynamics code was developed in [25] to study the performance of coupled fluid-structure interaction of point absorber in a 3D numerical wave tank. Numerical prediction can also enhance the knowledge in the preparations of experiments. The performance for two self-reacting point absorber with 1:25 scale was undertaken in heave motion [38], and the reactive control is reported can increase power capture for point absorber after conducting the numerical and experimental comparison. The key parameters to improve the performance of point absorber can be investigated by varying the parameters in the numerical simulation prior to the model test in the wave tank. Davidson et al. [39] proposed a general framework for the identification of linear and nonlinear parametric models numerically based on fully nonlinear Navier-Stokes equations. Cho and his co-workers [40] studied the point absorber by using relative heave motion in between the buoy and an inner dynamic system. They found that the maximum power can be obtained at the optimal spring and damper condition. Research on the buoy shape was studied as well in [41] for point absorber to determine the hydrodynamic and dynamic loads of a novel shape.

The computational method, together with experimental method, is utilized to enhance the power capture performance of point absorbers as well. Numerous researches were carried out to optimize the point absorber behaviors by using control schemes. A sliding angle self-tuning method was proposed in [42] to find the optimal sliding angle automatically to increase the point absorber power capture capability. The energy output of point absorber can be further enhanced by using control strategy, such as energy-based performance function. Gilloetaux and Ringwood [43] numerically developed a linear time-domain hydrodynamic program to simulate the heaving buoy motions under latching control strategy. Later, Bacelli et al. [44] further improved this model to allow constrained optimization problem to be reformulated in a nonlinear program through the discretization of power take-off force and of the motion of the buoy. The authors in [42] conducted experiment tests and reported that the overall efficiency of point absorber can be improved from 3.2% in particular configuration. Phase control technique was developed in [45] by adding a fully submerged mass to the point absorber to properly shift the device heave natural frequency and gain resonance of motion. In addition, declutching control mechanism was investigated in [46] to increase the power take-off performance of the point absorber. The power take-off parameters such as spring constant, stable equilibrium position, and mass ratio on the power capture were studied in [47] and they reported that the bi-stable point

absorber can harvest more wave energy than a linear point absorber when the wave frequency is less than the natural frequency. Moreover, implementation of visco-elastic model-based mooring line [48, 49] can be considered as a new area for station-keeping of floating objects.

Time domain numerical simulation of point absorber is significant to determine the dynamic performance of the system and maximum magnitude of time-varying parameters [50]. The time-domain nonlinear model of a 1:17 scale point absorber model under dynamic instability in regular waves was studied in [51]. On the other hand, Vicente and his co-workers [52] conducted a time-domain simulation to study the motions and power absorption of the point absorber in arrays of three and seven elements and for different mooring parameters and wave incidence angles.

The research in the deployment of point absorbers at a practical level is highly localized with respect to the different geographical and hydrological conditions, hence, site-specific design optimization is needed [53, 54]. Installed capacity factors for point absorber in North Atlantic and Equatorial Pacific regions were reported to be 0.8 at 25 kW/m and 0.5 at 75 kW/m as stated in [55]. However, one of the main challenges in the development point absorber in Malaysian seas is that the wave heights are relatively low, where the average wave energy density of Malaysian seas facing the South China Sea is in the range of 1.41 kW/m to 7.92 kW/m [56]. Also, Chong and Lam [57] reported that wave energy may not be suitable or commercially viable in Malaysia as wave energy conversion technology requires an average annual wave power density greater than 50 kW/m², where it is not readily available in Malaysia seas. The limitation of wave height in Malaysian seas emerges a research problem to the applicability of point absorber in this area. However, the residents in remote islands would experience the most direct impact once marine renewable energy is installed [58] and utilization of marine renewable energy is achievable with abundant supports from government and private sectors [59], it is worthy to investigate a more suitable type of point absorber in Malaysian seas. A previous investigation was conducted in [60] on an analysis of heave buoys response on Malaysian water and it suggested that the strategies of power output from heave buoy can be further enhanced in Malaysian water.

In addressing to the problem statements of applicability of point absorber in Malaysian water, the objectives of this paper are (i) to determine the sensitivity of different configurations of power take-off system in point absorber, and (ii) to numerically analyze the potential maximum power output to be generated by the point absorber in Malaysian water, under regular wave motion. The significance of this study leads to a better understanding of the envelope of power output generated by point absorber in Malaysian seas.

2. Theoretical Modelling

2.1 Formulation of Point Absorber

Based on Faraday's Law, the electromotive force (emf) of the j -th set of coils can be modeled as [30].

$$e_j(t) = - \sum_{i=n(j-1)+1}^{n \times j} NS \frac{dB}{dt} = B_m \frac{\pi \dot{z}_3(t)}{\tau} \cos\left(\frac{\pi z_3(t)}{\tau} + \varphi_i\right) \quad (1)$$

where φ_i is the phase difference between each coil tooth, B_m is the magnetic flux density (unit in Tesla, T), $z_3(t)$ is the heave displacement of the translator, N is the number of coil windings, S is the cross sectional area of the coil tooth, and τ is the length of the pole. For a point absorber to be connected into a three-phase Y-type equivalent circuit, the emf can be further represented as [61].

$$e_i = R_a i_i + L_s \frac{di_i}{dt} + V_i, \quad i = 1, 2, 3 \quad (2)$$

where e is the electromotive force (unit in Volt), R_a is the resistance, L_s is the inductance, i is the induced current, V is the induced voltage, d/dt is the derivative with respect to time. The input power (unit in Watt) to the point absorber is

$$P_{in} = \sum_{i=1}^3 e_i i_i \quad (3)$$

and the output power generated by the point absorber is represented as

$$P_{out} = i_i^2 R_L \quad (4)$$

where R_L is the load resistance in the circuit.

2.2 Malaysia Wave Condition

One of the main challenges in the development of extracting renewable energy from waves in Malaysia is the wave heights in Malaysian seas are relatively low, where the average wave energy density of Malaysian seas facing the South China Sea is in the range of 1.41 kW/m to 7.92 kW/m, while the energy storage varies from as low as 7.10 MW h/m to 69.41 MW h/m [56]. The performance of point absorber is potentially significant reduced due to the low wave energy density. In order to simulate the performance of point absorber in Malaysian seas condition, the input wave amplitude and wave period was determined by using meteorological data from Malaysian Meteorological Department (MET). The statistical wave data was processed from five years (2010 to 2015) data collection by MET. The statistical mean wave height and wave period, as shown in **Table 1**, were used to generate a regular wave input in the time-domain simulation to obtain the respective output power to be generated by the point absorber.

Table 1 Statistical wave condition in Malaysian seas*

	Wave height (m)	Wave period (s)
Mean	0.87	3.80
Standard deviation	0.74	2.71
Median	0.50	3.00
Mode	0.50	3.00
Maximum	5.00	15.00
Kurtosis	3.88	2.12
Skewness	1.66	1.21
Total number of sampling	620	620

3. Methodology

The flow chart of numerical analysis for point absorber of wave energy conversion is illustrated in **Fig. 1**. The study was started by the literature review on the point absorber and wave energy conversion. Later, the magnetic intensity for different power take-off system configurations was analyzed by using COMSOL Multiphysics software package. Three types of power take-off system models were simulated and the maximum magnetic flux density for each type was determined. The results of magnetic field were further used in the time-domain simulation model which was developed by the authors in SIMULINK under regular wave input condition based on Malaysian seas data. The electromotive force and induced power output under regular wave inputs were identified and the process was repeated until the targeted power output has been achieved.

* Data collection from ship observation by Malaysian Meteorological Department (MET), location at latitude from 4.0°N to 6.0°N and longitude from 104°E to 106°E, duration from 1st January 2010 to 31st December 2015.

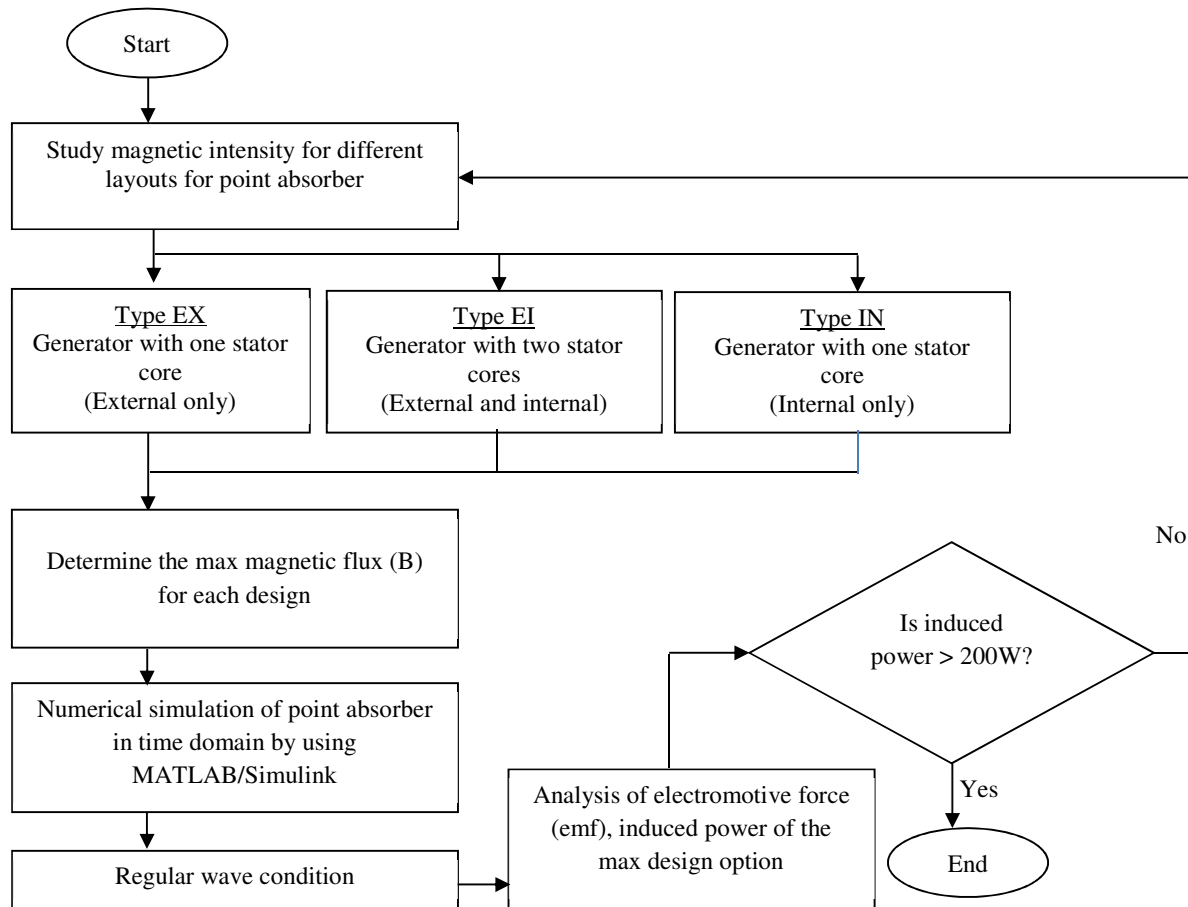

Fig. 1. Flow chart of numerical analyses for point absorber of wave energy conversion in Malaysian seas

3.1 Simulation of Power Take-Off System

The magnetic flux density of point absorber with different configurations is simulated in COMSOL Multiphysics package to determine the magnetic flux amplitude B_m in the Eq. (1). The modeling was conducted in a two-dimensional (2D) model of the cross-sectional area of the power take-off system in a point absorber. As shown in **Fig. 2(a)**, the 2D model consists of external coils, internal coils, neodymium magnet bars, polymer insulation layers, and air gaps in between the stators and translator. This model was meshed in fine elements as shown in **Fig. 2(b)**, where a total of 24,364 elements were constructed. This meshed model was used for different configurations in the simulations. The principal dimensions of this power take-off model are listed in **Table 2**.

Sensitivity of power take-off configurations was examined by simulating this model under three different configurations, as tabulated in **Table 3**. In the first configuration, the iron-based core with copper wire coils is circulated around the magnetics bars from external ring, while the internal coil in Figure 1 is regarded as void. This configuration is labeled as EX where its stator part is attached directly to the inner wall of outer casing and the translator (which refers to magnetic part in this case) is oscillated by the wave heave motion and translates vertically with respect to the stator to generate electricity. The second configuration is opposite with the first one where its stator is located inside magnetic ring and the external coil is regarded as void. Only internal iron-based core with copper wire coils interacts with the translator to generate electricity, hence this configuration is labeled as IN. This

IN configuration is common as in the works of [62] where the magnetic part (translator) is located in an external buoy structure which floats and oscillates with respect to the static center cylinder (stator). The third configuration is a combination of both external and internal coils, which is labeled as EI. In this configuration, the magnetic translator interacts with copper coils located on both internal and external sides. This configuration can increase the total area of magnetic flux cuttings without increasing the required space inside generator casing. However, the magnetic translator needs to move in between two stators within small air gaps, which requires very precise fabrication technology.

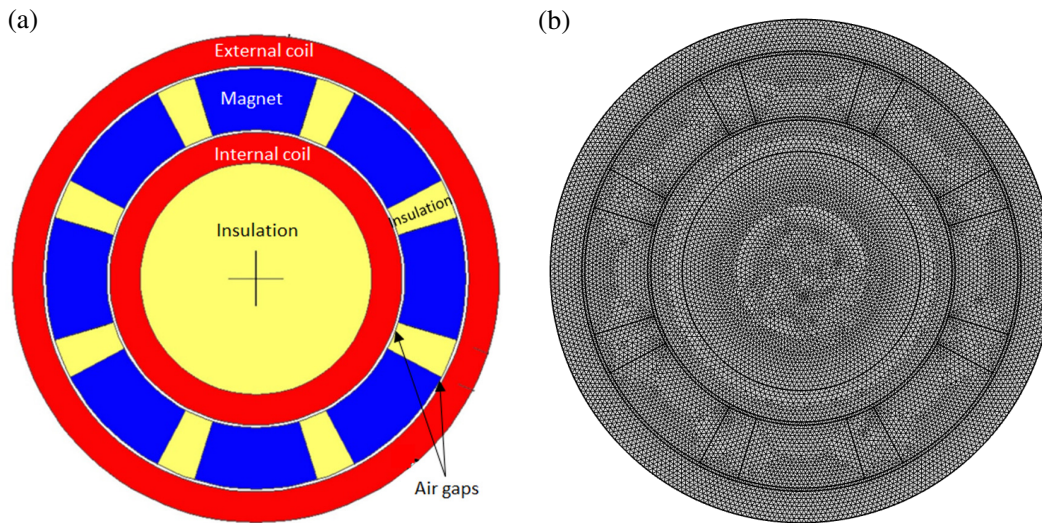

Fig. 2. (a) Two-dimensional layout of point absorber structure: iron cores and coils (red), neodymium magnet bars (blue), polymer insulation layers (yellow), and air gap (white), dimension in unit meter; (b) meshing of point absorber structure in COMSOL Multiphysics package

Table 2 Principal dimensions of power take-off system model

Parameter	Magnitude
Outer core diameter	1.50 m
Inner core diameter	0.86 m
Outer magnet length	0.40 m
Inner magnet length	0.28 m
Magnet thickness	0.20 m
Air gap	0.01 m
Magnet gap	0.132 m
Coercive magnetic field intensity, H_c	9.05×10^5 A/m
Magnetic permeability, μ	1.2×10^5 H/m
Number of elements	24364

Table 3 Configurations of power take-off system model

Configuration	External stator (ring core)	Internal stator (tubular core)
EX	Yes	No
IN	No	Yes
EI	Yes	Yes

3.2 Simulation of Point Absorber under Regular Wave Condition

The second analysis was conducted in time-domain simulation by using simulation model, which was developed by the authors, in SIMULINK. A simulation model was created based on the Eq. (1) - (4) as shown in **Fig. 3** to analyze the maximum power output to be generated by point absorber under regular wave inputs based on Malaysian seas condition, as listed in **Table 1**, and the magnetic flux intensity for different configurations.

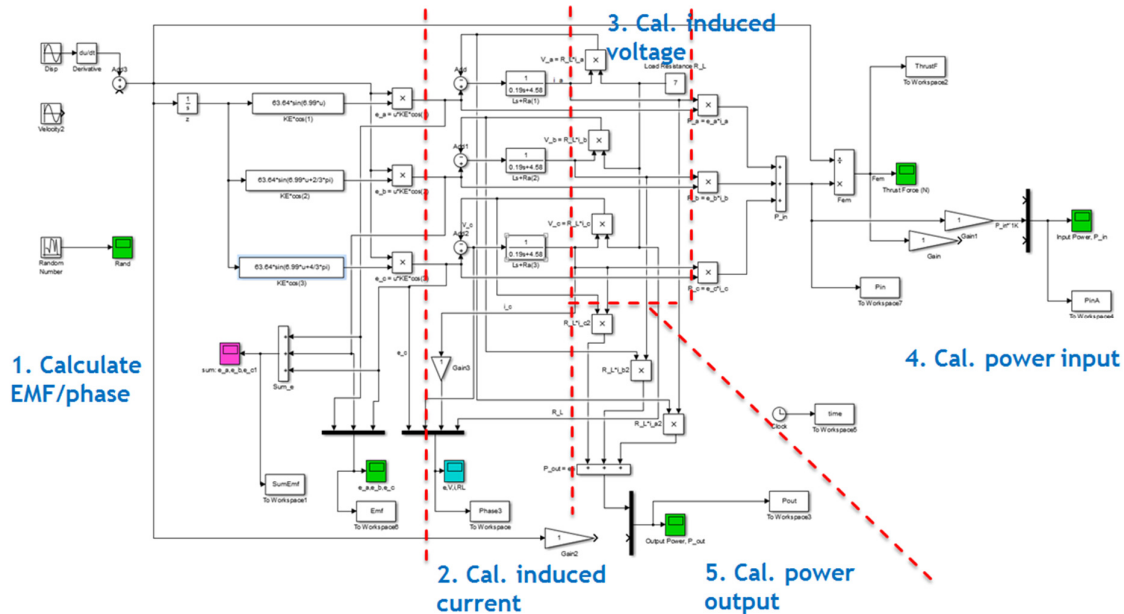

Fig. 3. Time-domain based simulation model for point absorber

4. Results and Discussion

The magnetic flux density for power take-off system model from static simulation is demonstrated in **Fig. 4** and the magnitude of maximum magnetic flux density for each configuration is tabulated in **Table 4**. The maximum magnetic flux density is 1.65 T, 1.27 T, and 2.40 T for the configurations of EX, IN, and EI, respectively. The largest maximum magnetic flux density was found in the configuration of EI, which is consisted of both external and internal iron-based cores. It is also noteworthy that the largest magnitude of maximum magnetic flux density is positively correlated with the total area of iron-based cores interacting with magnetic translator in the power take-off system. For instance, the configuration EX has a larger total area of iron-based core than the configuration IN, whereas the maximum magnetic flux density generated by configuration EX is larger than the one by configuration IN as well. This phenomenon is potentially caused by the iron-based cores can concentrate the magnetic flux in the power take-off system.

It can be found that the distributions of magnetic flux density are more even along the stator for the single-sided core configurations (EX and IN) than the double-sided cores configuration (EI). From **Fig. 4(a)**, a majority of the magnetic flux is concentrated in the external iron-based core while the flux intensity inside the internal air area is dispersed. The situation is similar on the **Fig. 4(b)** where majority magnetic flux is concentrated inwardly for IN configuration. The magnetic flux is concentrated on both external and internal side in the EI configuration. The distribution of flux in configuration EI is non-uniform as outcomes of interactions in between both external and internal cores. It is noteworthy that the cogging force was not considered in these cases.

The magnetic flux density as calculated in **Table 4** for power take-off system model is used to simulate the electromotive force (based on Eq. (1)), power input (based on Eq. (3)) and power output (based on Eq. (4)). The input parameters in the time domain simulation are tabulated in **Table 5**. Several assumptions had been made in this time domain simulation. Firstly, wave excitation is assumed in regular form, and the translator oscillates fully in accordance with the wave motion. This assumption is useful to identify the maximum envelope of output power for a wave energy converter. Secondly, the magnitude of parameters in **Table 5** is based on an arbitrary case. It leads to a room for improvement in further optimization of these parameters in the future design works. Thirdly, the cogging force in between the magnetic translator and the iron-based stators is not considered in this time domain simulation. Fourthly, the area of copper-wire coils in the double-sided cores configuration (EI) was set to be identical with the single-sided core configurations (EI and IN) in order to compare the effects of magnetic flux density on a consistent basis, hence only the external core in configuration EI was circulated with wire-copper coils in this study.

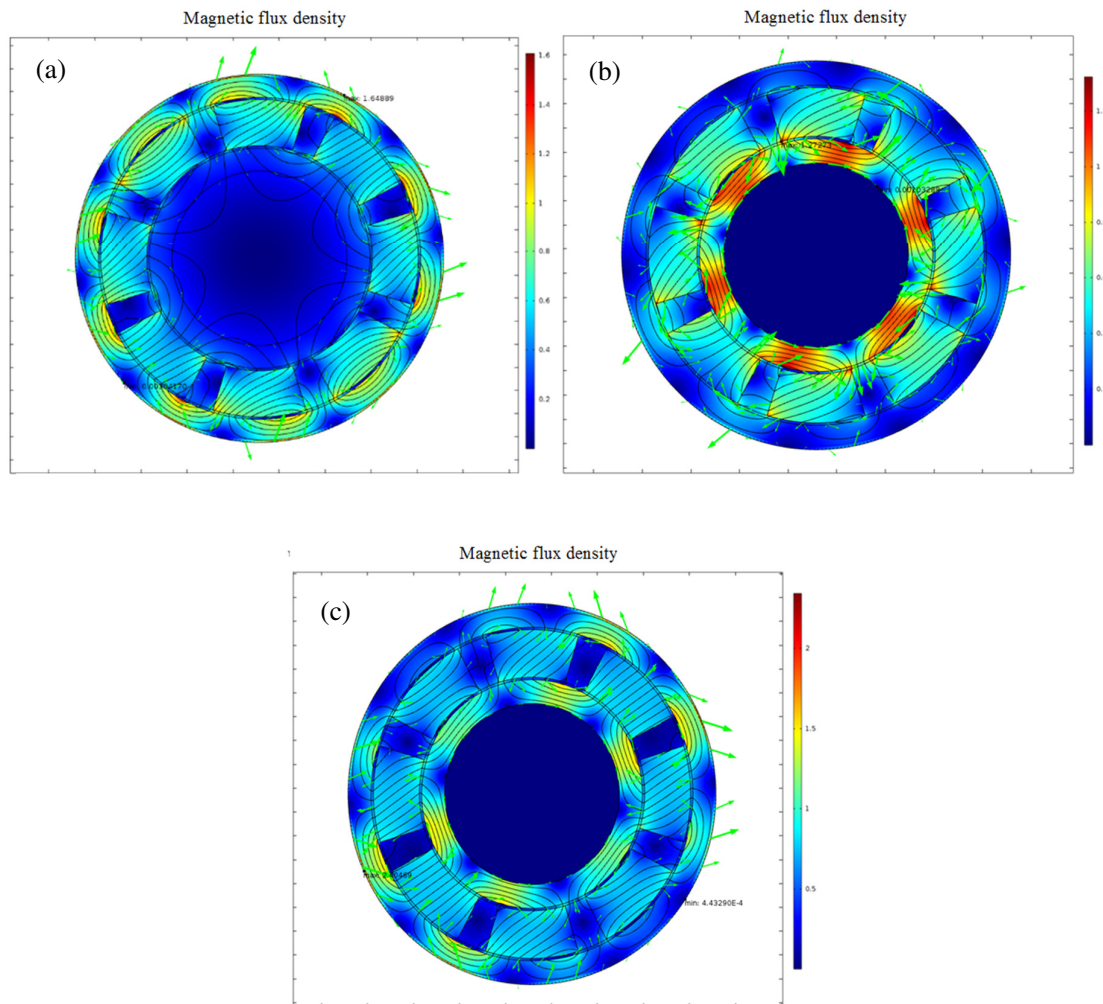

Fig. 4. Magnetic flux density for configurations (a) EX, (b) IN, and (c) EI

The maximum envelope of output power for configurations EX, IN, and EI are 273 W, 163 W and 581 W, respectively, under regular wave motion. It is noteworthy that the regular wave motion based

on Malaysian seas conditions is regarded as ideal cases because the actual seas are in irregular motion. The results in **Table 6** provide a maximum envelope for the researchers to examine the maximum power output to be generated by each configuration of point absorber under the parameters setting in **Table 5**.

Table 4 Magnetic flux density

	Maximum flux density (T)	Minimum flux density (T)
EX	1.64889	0.00304
IN	1.27273	0.00103
EI	2.40469	0.00043

Table 5 Input parameters to time domain simulation

Parameter	Value
Load resistance, R_L	7 Ω
Synchronous inductance, L_s	0.19 H
Armature resistance, R_a	4.58 Ω
Number of coil turn, n	500 turn
Simulation fixed step size	0.001 s
Simulation solver	ODE4 (Runge-Kutta)

Table 6 Induced electromotive force and amplitude of powers

	Power Input (W)	Power Output (W)	Induced emf (V)
EX	452 W	273 W	51.9 V
IN	269 W	163 W	40.1 V
EI	961 W	581 W	75.7 V

It can be found that point absorber with internal core and coils (IN) is not suitable in Malaysia seas condition as it generated only 163 W in this simulated case. A more feasible selection is point absorber with external core and coils (EX), which has relatively a larger total surface area of the iron-based core to concentrate the magnetic flux and increase the magnetic intensity. On the other hand, the configuration with both internal and external core and coils (EI) can generate largest power output envelope, which is up to 581 W, in this case setting. However, the fabrication of this EI configuration needs highly precise technology. If the technology of high precision fabrication can be unlocked, then this type of point absorber can be readily considered to be deployed in Malaysian seas as the wave energy conversion device.

The power input to point absorber, based on Eq. (3), under regular wave condition in **Table 1** for configuration EI is shown in **Fig. 5**. The maximum power input is referred to the amount of wave power to be transferred into the point absorber that is potentially converted into electricity. It can be shown that the amplitude of power input is 961 W and in sinusoidal form. On the other hand, the maximum power output, based on Eq. (4), under the given regular wave motion to the point absorber is shown in **Fig. 6**. The amplitude of power output is 581 W. It can be found that the total efficiency of energy conversion for the point absorber model in this simulation is 60% under ideal regular wave input. The electromotive force, based on Eq. (1), induced by the point absorber under regular wave condition is shown in **Fig. 7**. The electromotive force is generated in a three-phase form where each phase has an interval of 120°. The electromotive group under regular wave motion is in proper group wave form. The induced voltage and induced current, based on Eq. (3), is shown in **Fig. 8**. It is noteworthy that the regular wave motion based on Malaysian seas conditions is regarded as ideal cases because the condition of actual seas is in the irregular motion. The actual input and output power in real sea conditions are estimated to be lower than these magnitudes simulated under regular wave

condition. Hence, the simulation results provide an envelope of maximum power output that can be generated by a specific point absorber configuration, under the given Malaysian wave condition.

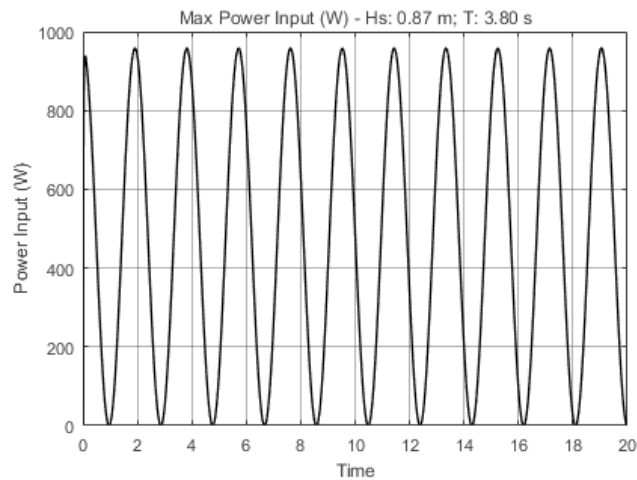

Fig. 5. Power input (potential wave energy) to point absorber under regular wave for configuration EI

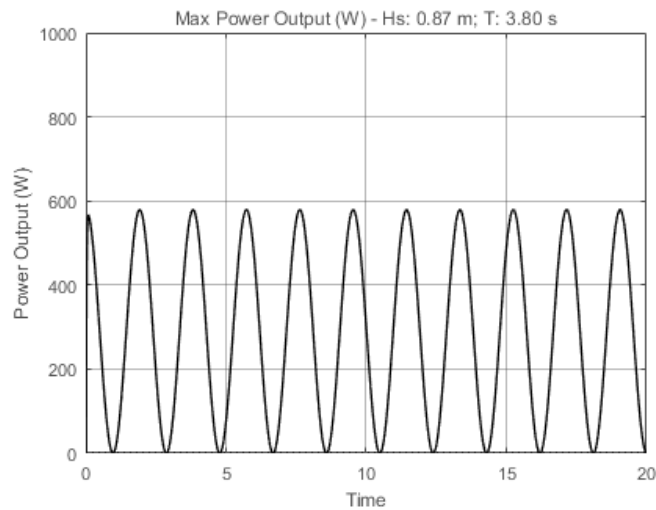

Fig. 6. Power output generated from point absorber under regular wave for configuration EI

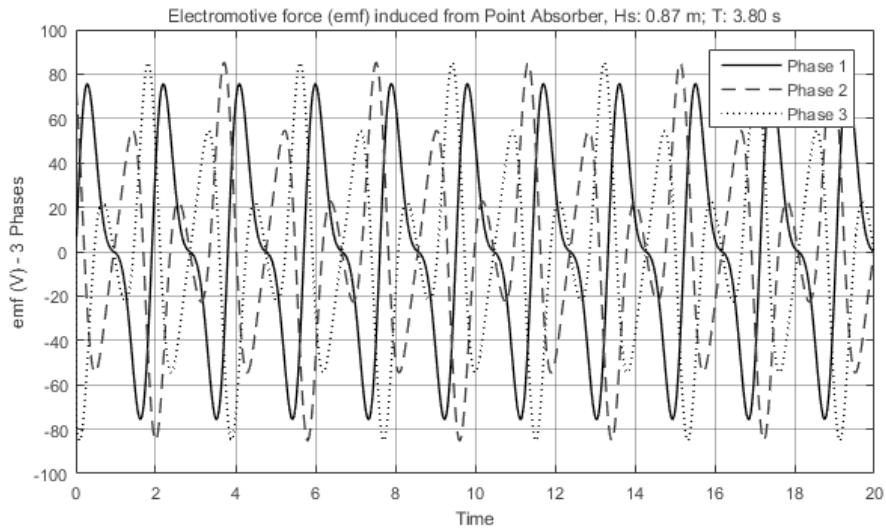

Fig. 7. Electromotive force (emf) induced from point absorber under regular wave for configuration EI

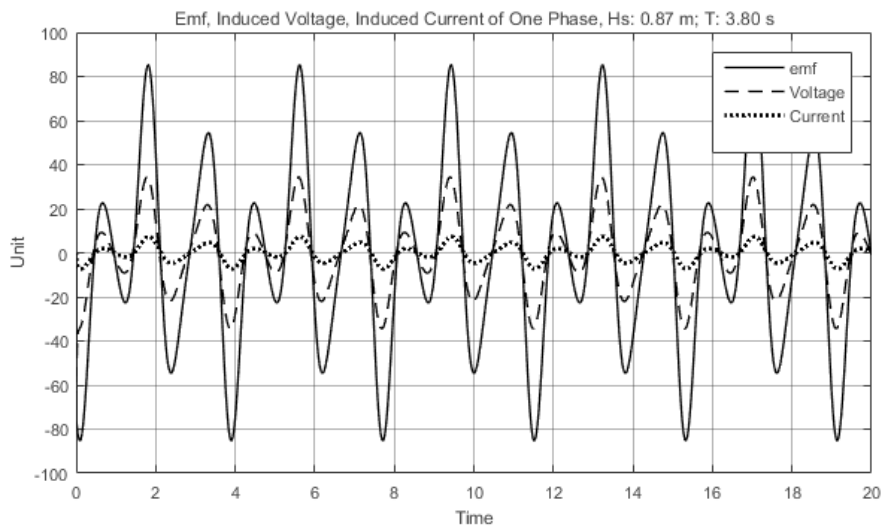

Fig. 8. Electromotive force (emf), induced voltage and induced current from point absorber under regular wave for configuration EI

The maximum power output of point absorber configuration EI under different wave heights and wave periods is illustrated in **Fig. 9**. This surface shows that the maximum power output of point absorber is highly dependable to the wave height and wave period. The higher wave height and shorter wave period can increase the maximum power output to be generated by point absorber under EI configuration. This finding could be useful for the further design of point absorber the coastal regions with shorter wave.

5. Conclusion

In this paper, the sensitivity of different configurations of power take-off system in point absorber has been identified. The distribution of magnetic flux density in a double-sided stator configuration is larger than the one found in a single-sided stator. The maximum magnetic flux in the proposed simulation configuration is around 2.4 T. Iron-based core stator can concentrate the magnetic flux, however, a double-sided stator requires nonlinear computational analysis due to the interaction in

between both external and internal stator. Time-domain simulation on the behaviors of point absorber based on Faraday's Law was used to simulate the maximum power output of the wave energy conversion. The envelope of maximum power output to be generated by the particular double-sided stator point absorber in Malaysian water, under regular wave motion of 0.87 m wave amplitude and 3.80 seconds wave period, has been found as 581 W. This power capture ability is feasible only if the high precision fabrication technology for point absorber has been achieved. A better understanding for the envelope of power output generated by point absorber in Malaysian seas can provide the researchers a useful prediction tool for determining the applicability of point absorber in Malaysia.

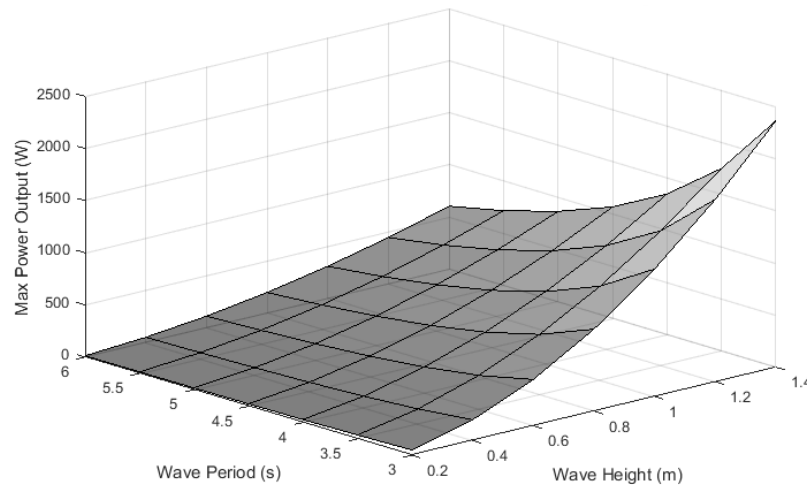

Fig. 9. Maximum power output of point absorber for configuration EI under different wave heights and wave periods

Acknowledgement

The authors would like to appreciate Universiti Teknologi Malaysia for supports from Potential Academic Staff Grant no. 02K43. Also, the authors would like to express gratitude to Department of Mathematical Sciences at UTM for resource support.

References

- [1] O'Boyle, L., Elsässer, B. and Whittaker, T. "Methods to enhance the performance of a 3D coastal wave basin." *Ocean Engineering* 135 (2017): 158-169.
- [2] Jeffcoate, P., Whittaker, T., Boake, C. and Elsaesser, B. "Field tests of multiple 1/10 scale tidal turbines in steady flows." *Renewable Energy* 87 (2016): 240-252.
- [3] Draper, S., Adcock, T.A.A., Borthwick, A.G.L. and Housby, G.T. "Estimate of the tidal stream power resource of the Pentland Firth." *Renewable Energy* 63 (2014): 650-657.
- [4] Draper, S., Adcock, T.A.A., Borthwick, A.G.L. and Housby, G.T. "A note on the power potential of tidal currents in channels." *International Journal of Marine Energy* 6 (2014): 1-17.
- [5] Ramos, V. and Ringwood, J.V. "Implementation and evaluation of the International Electrotechnical Commission specification for tidal stream energy resource assessment: A case study." *Energy Conversion and Management* 127 (2016): 66-79.
- [6] Lim, Y.S. and Siong, L.K. "Analytical assessments on the potential of harnessing tidal currents for electricity generation in Malaysia." *Renewable Energy* 35 (2010): 1024-1032.

- [7] Buccino, M., Vicinanza, D., Salerno, D., Banfi, D. and Calabrese, M. "Nature and magnitude of wave loadings at seawave slot-cone generators." *Ocean Engineering* 95 (2015): 34-58.
- [8] Contestabile, P., Iuppa, C., Lauro, D., Cavallaro, L., Andersen, T.L. and Vicinanza, D. "Wave loadings acting on innovative rubble mound breakwater for overtopping wave energy conversion." *Coastal Engineering* 122 (2017): 60-74.
- [9] Liu, Z., Shi, H., Cui, Y. and Kim, K. "Experimental study on overtopping performance of a circular ramp wave energy converter." *Renewable Energy* 104 (2017): 163-176.
- [10] Folley, M. and Whittaker, T. "Validating a spectral-domain model of an OWC using physical model data." *International Journal of Marine Energy* 2 (2013): 1-11.
- [11] Arena, F., Romolo, A., Malara, G. and Ascanelli, A. "On design and building of a U-OWC wave energy converter in the Mediterranean Sea: a case study." In *ASME 2013 32nd International Conference on Ocean, Offshore and Arctic Engineering*, 2013.
- [12] Boake, Cuan, B., Whittaker, T.J.T., Folley, M. and Ellen, H. "Overview and initial operational experience of the LIMPET wave energy plant." In *The Twelfth International Offshore and Polar Engineering Conference*, 2002.
- [13] Boccotti, P. "On a new wave energy absorber." *Ocean Engineering* 30 (2003): 1191-1200.
- [14] Shirasawa, K., Tokunaga, K., Iwashita, H. and Shintake, T. "Experimental verification of a floating ocean-current turbine with a single rotor for use in Kuroshio currents." *Renewable Energy* 91 (2016): 189-195.
- [15] Yang, X., Haas, K.A., Fritz, H.M., French, S.P., Shi, X., Neary, V.S. and Gunawan, B. "National geodatabase of ocean current power resource in USA." *Renewable and Sustainable Energy Reviews* 44 (2015): 496-507.
- [16] Tsao, C.C., Feng, A.H., Hsieh, C. and Fan, K.H. "Marine current power with Cross-stream Active Mooring: Part I." *Renewable Energy* 109 (2017): 144-154.
- [17] Sun, F., Ikegami, Y., Jia, B. and Arima, H. "Optimization design and exergy analysis of organic rankine cycle in ocean thermal energy conversion." *Applied Ocean Research* 35 (2012): 38-46.
- [18] Rajagopalan, K. and Nihous, G.C. "Estimates of global Ocean Thermal Energy Conversion (OTEC) resources using an ocean general circulation model." *Renewable Energy* 50 (2013): 532-540.
- [19] Cusick, R.D., Kim, Y. and Logan, B.E. "Energy capture from thermolytic solutions in microbial reverse-electrodialysis cells." *Science* 335 (2012): 1474-1477.
- [20] French, M.J. and Bracewell, R. "Heaving point absorbers reacting against an internal mass." In *Hydrodynamics of Ocean Wave-Energy Utilization*, pp. 247-255, 1986.
- [21] Korde, U.A. "On providing a reaction for efficient wave energy absorption by floating devices." *Applied Ocean Research* 21 (1999): 235-248.
- [22] Weinstein, A., Fredrikson, G., Parks, M.J. and Nielsen, K. "AquaBuOY-the offshore wave energy converter numerical modelling and optimization." In *OCEANS'04. MTS/IEEE TECHNO-OCEAN'04*, pp. 1854-1859, 2004.
- [23] Eriksson, M., Isberg, J. and Leijon, M. "Hydrodynamic modelling of a direct drive wave energy converter." *International Journal of Engineering Science* 43 (2005): 1377-1387.
- [24] Hals, J., Taghipour, R. and Moan, T. "Dynamics of a force-compensated two-body wave energy converter in heave with hydraulic power take-off subject to phase control." In *7th European Wave and Tidal Energy Conference*, 2007.
- [25] Agamloh, E.B., Wallace, A.K. and Jouanne, A.V. "Application of fluid-structure interaction simulation of an ocean wave energy extraction device." *Renewable Energy* 33 (2008): 748-757.
- [26] Beatty, S.J., Hiles, C., Nicoll, R.S., Adamson, J.E. and Buckham, B.J. "Design synthesis of a wave energy converter." In *ASME 2009 28th International Conference on Ocean, Offshore and Arctic Engineering*, pp. 891-900, 2009.
- [27] Elwood, D., Yim, S.C., Prudell, J., Stillinger, C., von Jouanne, A., Brekken, T., Brown, A. and Paasch, R. "Design, construction, and ocean testing of a taut-moored dual-body wave energy converter with a linear generator power take-off." *Renewable Energy* 35 (2010): 348-354.
- [28] Yeung, R.W., Peiffer, A., Tom, N. and Matlak, T. "Design, analysis, and evaluation of the UC-Berkeley wave-energy extractor." *Journal of Offshore Mechanics and Arctic Engineering* 134 (2012): 021902.
- [29] Cândido, J.J. and Justino, P.A.P.S. "Modelling, control and pontryagin maximum principle for a two-body wave energy device." *Renewable Energy* 36 (2011): 1545-1557.
- [30] Cochet, C. and Yeung R.W. "Dynamic analysis and configuration design of a two-component wave-energy absorber." In *ASME 2012 31st International Conference on Ocean, Offshore and Arctic Engineering*, pp. 631-640, 2012.

- [31] Henriques, J.C.C., Lopes, M.F.P., Gomes, R.P.F., Gato, L.M.C. and Falcao, A.F.O. "On the annual wave energy absorption by two-body heaving WECs with latching control." *Renewable Energy* 45 (2012): 31-40.
- [32] Tom, N. and Yeung, R.W. "Performance Enhancements and Validations of a Generic Ocean-Wave Energy Extractor." *Journal of Offshore Mechanics and Arctic Engineering* 135 (2013): 041101.
- [33] De Andres, A.D., Guanache, R., Armesto, J.A., Del Jesus, F., Vidal, C. and Losada, I.J. "Time domain model for a two-body heave converter: Model and applications." *Ocean Engineering* 72 (2013): 116-123.
- [34] Wu, B., Wang, X., Diao, X., Peng, W. and Zhang, Y. "Response and conversion efficiency of two degrees of freedom wave energy device." *Ocean Engineering* 76 (2014): 10-20.
- [35] Mérigaud, A. and Ringwood, J.V. "Condition-based maintenance methods for marine renewable energy." *Renewable and Sustainable Energy Reviews* 66 (2016): 53-78.
- [36] Coiro, D.P., Troise, G., Calise, G. and Bizzarrini, N. "Wave energy conversion through a point pivoted absorber: Numerical and experimental tests on a scaled model." *Renewable Energy* 87 (2016): 317-325.
- [37] Ghasemi, A., Anbarsooz, M., Malvandi, A., Ghasemi, A. and Hedayati, F. "A nonlinear computational modeling of wave energy converters: A tethered point absorber and a bottom-hinged flap device." *Renewable Energy* 103 (2017): 774-785.
- [38] Beatty, S.J., Hall, M., Buckham, B.J., Wild, P. and Bocking, B. "Experimental and numerical comparisons of self-reacting point absorber wave energy converters in regular waves." *Ocean Engineering* 104 (2015): 370-386.
- [39] Davidson, J., Giorgi, S. and Ringwood, J.V. "Linear parametric hydrodynamic models for ocean wave energy converters identified from numerical wave tank experiments." *Ocean Engineering* 103 (2015): 31-39.
- [40] Cho, I.H., Kim, M.H. and Kweon, H.M. "Wave energy converter by using relative heave motion between buoy and inner dynamic system." *Ocean Systems Engineering* 2 (2012): 297-314.
- [41] Jakobsen, M.M., Beatty, S., Iglesias, G. and Kramer, M.M. "Characterization of loads on a hemispherical point absorber wave energy converter." *International Journal of Marine Energy* 13 (2016): 1-15.
- [42] Do, H.T., Dinh, Q.T., Nguyen, M.T., Phan, C.B., Dang, T.D., Lee, S., Park, H.G. and Ahn, K.K. "Proposition and experiment of a sliding angle self-tuning wave energy converter." *Ocean Engineering* 132 (2017): 1-10.
- [43] Gilloteaux, J.C. and Ringwood, J. "Control-informed geometric optimisation of wave energy converters." *IFAC Proceedings* 43 (2010): 366-371.
- [44] Bacelli, G., Ringwood, J.V. and Gilloteaux, J.C. "A control system for a self-reacting point absorber wave energy converter subject to constraints." *IFAC Proceedings* 44 (2011): 11387-11392.
- [45] Piscopo, V., Benassai, G., Cozzolino, L., Morte, R.D. and Scamardella, A. "A new optimization procedure of heaving point absorber hydrodynamic performances." *Ocean Engineering* 116 (2016): 242-259.
- [46] Zhang, X.T., Yang, J.M. and Xiao, L.F. "Declutching control of a point absorber with direct linear electric PTO systems." *Ocean Systems Engineering* 4 (2014): 63-82.
- [47] Xiao, X., Xiao, L. and Peng, T. "Comparative study on power capture performance of oscillating-body wave energy converters with three novel power take-off systems." *Renewable Energy* 103 (2017): 94-105.
- [48] Ma, G., Sun, L. and Wang, H. "Implementation of a visco-elastic model into slender rod theory for deepwater polyester mooring line." In *ASME 2014 33rd International Conference on Ocean, Offshore and Arctic Engineering*, 2014.
- [49] Ma, G., Sun, L., Kang, Y. and Xu, L. "Effects of different influence factors on static and dynamic analysis of mooring line." *International Journal of Engineering and Technology* 7 (2015): 95.
- [50] Zurkinden, S.A., Ferri, F., Beatty, S., Kofoed, J.P. and Kramer, M.M. "Non-linear numerical modeling and experimental testing of a point absorber wave energy converter." *Ocean Engineering* 78 (2014): 11-21.
- [51] Tarrant, K. and Meskell, C. "Investigation on parametrically excited motions of point absorbers in regular waves." *Ocean Engineering* 111 (2016): 67-81.
- [52] Vicente, P.C., António, F.O., Gato, L.M.C. and Justino, P.A.P. "Dynamics of arrays of floating point-absorber wave energy converters with inter-body and bottom slack-mooring connections." *Applied Ocean Research* 31 (2009): 267-281.
- [53] Bozzi, S., Giassi, M., Miquel, A.M., Antonini, A., Bizzozero, F., Gruosso, G., Archetti, R. and Passoni, G. "Wave energy farm design in real wave climates: the Italian offshore." *Energy* 122 (2017): 378-389.
- [54] Khojasteh, D. and Kamali, R. "Evaluation of wave energy absorption by heaving point absorbers at various hot spots in Iran seas." *Energy* 109 (2016): 629-640.

- [55] Khan, N., Kalair, A., Abas, N. and Haider, A. "Review of ocean tidal, wave and thermal energy technologies." *Renewable and Sustainable Energy Reviews* 72 (2017): 590-604.
- [56] Yaakob, O., Hashim, F.E., Omar, K.M., Din, A.H.M. and Koh, K.K. "Satellite-based wave data and wave energy resource assessment for South China Sea." *Renewable Energy* 88 (2016): 359-371.
- [57] Chong, H.Y. and Lam, W.H. "Ocean renewable energy in Malaysia: The potential of the Straits of Malacca." *Renewable and Sustainable Energy Reviews* 23 (2013): 169-178.
- [58] Lim, X.L. and Lam, W.H. "Public acceptance of marine renewable energy in Malaysia." *Energy Policy* 65 (2014): 16-26.
- [59] Lim, X.L., Lam, W.H. and Hashim, R. "Feasibility of marine renewable energy to the Feed-in Tariff system in Malaysia." *Renewable and Sustainable Energy Reviews* 49 (2015): 708-719.
- [60] Amir, M.A.U., Sharip, R.M., Muda, W.B.H.W, Shukran, M.A.M, Anuar, H.A. and Zakaria, O. "Heave Buoy Energy Converters; Simulation of heave buoy response to wave in Malaysian water." *Energy Procedia* 62 (2014): 101-111.
- [61] Parthasarathy, R. Linear PM Generator for wave energy conversion (PhD dissertation). Faculty of the Louisiana State University and Agricultural and Mechanical College, Anna University, 2012.
- [62] Prudell, J., Stoddard, M., Amon, E., Brekken, T.K.A. and von Jouanne, A. "A permanent-magnet tubular linear generator for ocean wave energy conversion." *IEEE Transactions on Industry Applications* 46 (2010): 2392-2400.