

ISSN (print): 2421-6798

ISSN (on line): 2421-7158



Consiglio Nazionale delle Ricerche

IRCFES

ISTITUTO DI RICERCA SULLA CRESCITA ECONOMICA SOSTENIBILE
RESEARCH INSTITUTE ON SUSTAINABLE ECONOMIC GROWTH

Working Paper

Numero 3/2016

Technology Modelling and Technology Innovation
How a technology model may be useful in studying the innovation process

Angelo Bonomi and Mario Andrea Marchisio



WORKING PAPER CNR-IRCRES

Anno 2, Numero 3, Ottobre 2016

Direttore Responsabile

Secondo Rolfo

Direzione e Redazione

CNR-IRCRES

Istituto di Ricerca sulla crescita economica sostenibile

Via Real Collegio 30, 10024 Moncalieri (Torino), Italy

Tel. +39 011 6824.911

Fax +39 011 6824.966

segreteria@ircres.cnr.it

www.ircres.cnr.it

Sede di Roma

Via dei Taurini 19, 00185 Roma, Italy

Tel: 06 49937809

Fax: 06 49937808

Sede di Milano

Via Bassini 15, 20121 Milano, Italy

Tel: 02 23699501

Fax: 02 23699530

Sede di Genova

Università di Ge Via Balbi, 6 - 16126 Genova

Tel: 010-2465.459

Fax: 010-2099.826

Segreteria di redazione

Enrico Viarisio

enrico.viarisio@ircres.cnr.it



Technology Modelling and Technology Innovation

How a technology model may be useful in studying
the innovation process

*Angelo Bonomi**

Research Associate CNR-IRCrES,

National Research Council of Italy, Research Institute on Sustainable Economic Growth,
Via Real Collegio 30, Moncalieri (TO)

Mario Andrea Marchisio

Associate Professor School of Life Science and Technology,

Harbin Institute of Technology, Harbin, People's Republic of China

* Corresponding author:

Mail: abonomi@bluewin.ch

ABSTRACT: This work concerns an extension of a mathematical model of technology developed at the Santa Fe Institute in the late nineties. It is based on analogies existing between technological and biological evolution and not on economic principles. This extension has the purpose to make the model useful in the studies of the innovation process. The model considers technology activity, independently of possible economic purposes, and having its own properties, structure, processes as well as an evolution independently by economic factors but more similar to biologic evolution. Considered purpose of technology is reaching of a technical result and not necessarily an economic result. The model considers technology as a structured set of technological operations that may be represented by a graph or matrix. That opens a description of a technology in term of technological spaces and landscapes, as well as in term of spaces of technologies, in which it is possible to represent search of optimal and evolutive paths of technologies, changes in their efficiency and measure of their radical degree linked to their technological competitiveness. The model is presented in a descriptive way and its mathematical development is presented in annex. The main applications of the model concern the use of the defined radical degree of a technology linked to its technological competitiveness.

In this way it is explained the existence of Red Queen Regimes, characterized by continuous technical but not economical developments, among firms producing the same product. Such regimes are disrupted only by the entering of a technology with a high radical degree. Changes in operational structure of technologies may suggest the existence of three types of technology innovations, the first concerning learning by doing and consisting in minor changes giving incremental innovations, the second and the third, both able to obtain radical innovations through R&D activity, but the second exploiting scientific results and the third based only on a combinatory process of pre-existing technologies. This last way of innovation may explain the innovative potential, existing for example in Italian industrial districts, without resorting to any scientific research.

KEYWORDS: technology model, technology innovation, research & development, learning by doing

JEL CODES: C60, D20, D21, O30

CONTENTS

1. INTRODUCTION.....	5
2. THE MODEL OF TECHNOLOGY	8
2.1 <i>Definition of technology</i>	8
2.2 <i>Structure of the technology and the technological space</i>	8
2.3 <i>Space of technologies</i>	9
2.4 <i>Efficiency of technologies</i>	10
2.5 <i>Technology landscape</i>	11
2.6 <i>Intranality and externality of a technology</i>	12
3. APPLICATION OF THE MODEL TO THE INNOVATION PROCESS	13
3.1 <i>Technological competitiveness</i>	13
3.2 <i>Types of technology innovation activities</i>	15
3.3 <i>Effects of technology intranality on the innovation process</i>	18
3.4 <i>Other applications of the model</i>	20
4. CONCLUSIONS	20
BIBLIOGRAPHY	22
ANNEX.....	24
1.1 <i>MATHEMATICAL MODEL OF TECHNOLOGY</i>	24
A1. <i>Technology</i>	24
A2. <i>Technological recipes and technological space</i>	26
A3. <i>Space of technologies</i>	28
A4. <i>Efficiency of technologies and technology landscape</i>	29
A5. <i>Intranality and externality of a technology</i>	31
FIGURES	34

1. INTRODUCTION

There is an enormous amount of writings and textbooks on relation between technology and economy, investments and availability of new technologies, diffusion of technologies among firms, as well as specific properties attributed to technology influencing behaviour of enterprises, etc. However technology activity is not necessary always linked to economical activities but may be carried out for other purposes. The Manhattan Project for the development of nuclear weapons is probably the greatest R&D project never done and it has generated a great amount of new technologies that only in part were indirectly exploitable for economic purposes (Rhodes 1986). In fact technology innovations are not generated by capitals but capitals attired by innovative ideas generated by specific innovative processes. That means also that a technology has its own properties, structure, processes as well as an evolution independently by economic factors but more similar to biologic evolution (Basalla 1988). Purpose of technology is considered in this work the reaching of a technical result and not necessarily an economic result. The development of a mathematical model for technology may be useful for studying the innovation process, not necessarily from an economic point of view, but considering the technological aspects of the process. In this work we have extended a model of technology developed at beginning of nineties at the Santa Fe Institute for learning by doing activities to also R&D activities. The Santa Fe Institute, dedicated

to the transdisciplinary science of complexity, was created in 1986, and had among its founders George Cowan, former scientist at Los Alamos National Laboratories and first President of the Institute, Murray Gell-Mann, Nobel Prize in physics, as well as many supporters in particular Kenneth Arrow, Nobel Prize in economy. Among the first fellows of this Institute we had Brian Arthur, an economist, well known for his studies on existence of increasing returns in economy, at that time professor at the University of Stanford, and Stuart Kauffman, a theoretical biologist, well known for mathematical modelling of genes interactions, at that time professor at the University of Pennsylvania. A discussion about technology between these two scholars, occurred in the second half of eighties at the Santa Fe Institute, is in fact at the origin of the model, and it has been reported in detail in a book describing foundation and main ideas characterizing the Institute (Waldrop 1992). The discussion started on nature of technological change and Brian Arthur observed that economists did not have any fundamental theory and treated technology as generated from nothing, falling from sky under form of projects such as production of steel or fabrication of silicon chips or any other things. In fact in the past technology, continued Brian Arthur, was not considered as part of economy but an exogenous factor. More recently there was the tentative to build up models of technology endogenously produced by the economic system, as result of investments in R&D and considered as any other good. Brian Arthur thought that this view was not

completely erroneous but that was not the core of the problem. Considering the history of technology it does not resemble as a good, in fact technologies do not come from nothing but are often prepared by previous technological innovations and technology may be better considered as an ecosystem in evolution. Stuart Kauffman argued that technologies form strongly interconnected, dynamic and instable networks. Such networks may present explosions of creativity and mass extinctions as in biological ecosystem. Brian Arthur observed that such processes are a good example of his concept on increasing returns as a new technology may create new niches for goods and services and asked to Kauffman why not to try the development of a model in which technology is activated at the moment of its creation and not appearing at the moment in which its effects are observed. That opened the idea to treat mathematically a technology, considered as a set of operations, similarly to a set of genes operating in a biological entity, and considering technological mutation similar to that of the origin of life, a research field in which Stuart Kauffman was active since fifteen years. Following this discussion Brian Arthur continued to study the core aspects of technology developing later the idea that technology is the result of a combinatorial process of previous technologies able to exploit new discoveries of science (Arthur 2009). On the other side Stuart Kauffman joined a team of researchers at the Santa Fe Institute to develop a model of technology. First of all, the team considered technology as a process consisting in a set of technological

operations. This approach is more general than a more common view seeing technology as an artefact and its evolution as a modification or change in its components (Basalla 1988). In fact any technological artefact may be described as the result of an assembling operation of a set of components. On the contrary, seeing technology as an artefact, in certain cases, as in chemical technologies, the product may be generated by different technologies that the simple knowledge of the product, or artefact, cannot characterize the technology. The mathematical approach was based on the NK model (Kauffman, Levin 1987) used for modelling interactions among genes in biological entities (Kauffman 1993). In this case genes were substituted by technological operations. Incidentally it may be noted that the NK model would be used later also in a mathematical model considering technology as an artefact composed by a set of components (Frenken 2001). The description of the model appeared for the first time in 1998 as Working Paper of the Santa Fe Institute and published later on the Journal of Economic Dynamics and Control (Auerswald, Kauffman, Lobo, Shell, 2000). In this article the model was shown able to reproduce the experience curve showing the decline of labor costs with cumulative production of a given manufactured good, observed at first in airframe industry (Wright 1936). One of the interesting aspects of the model concerns the use of the concept of fitness landscape (Altenberg 1996) describing the fitness allure in a space defined by a set of configurations corresponding, in technology modelling, to operative conditions of a technology that

may be represented in a fitness landscape called in this case technology landscape. Such landscape was further used in studying technology innovation in search of optimal conditions of efficiency (Kauffman, Lobo, Macready 2000), in term of adaptive explorative walk (Lobo, Macready 1999) as well as in a study on recombinant search in the invention process (Fleming, Sorenson 2001). Technology landscapes have been even used, not necessarily as mathematical tools, in discussing certain aspects of technology management (Strumsky, Lobo 2002) and in technological search in landscapes mapped by scientific knowledge (Fleming, Sorenson 2004).

One of the limits of Kauffman's model is the fact it considers only interactions among an established set of operations constituting a single technology. Such approach is valid for example for learning by doing in which technology change concerns mainly optimizing of operative conditions. However, when considering technology innovation, as for example resulting from R&D activity, the new technology may be the result of a change, not only in term of operative conditions, but also in the operations in respect to a previous technology. However in this case the technology change cannot be described using a simple set because operations are carried out by temporal structured sequences that may be in series or in parallel corresponding consequently to different technologies. Such structures may be described by using the theory of graphs. This study uses the mathematical application of this theory in order to improve the Kauffman's model, and then enabling a general description of

technological innovation in term of changes of previous technologies, and not only in term of change in operative conditions of a single technology. Expectations of such improved model are for example the definition of various ways to carry out technology innovation and a better definition of innovation characteristics in terms for example of incremental or radical technology innovations. The use of this model may find applications in improving knowledge, management and planning of R&D activities, as well as in technology innovation management. The operations structure of technology defined by the model may be useful also in assessing technologies by considering knowledge and history of single operations composing a technology and their interactions, and not just only technology in general terms. The model shows only marginal economic involvements that concern the technological competitiveness and indirectly economic studies on R&D activity. In fact technology is not really a good, as argued previously, its cost (investment in R&D) is strongly dependent on varying available knowledge, and its value strongly dependent by an instable interconnected and dynamic ecosystem characterized by explosion of entering of new technologies and mass extinction of existing technologies. On the other side the model concept is clearly in agreement with a Schumpeterian view of economic evolution, in opposition to the classical view of economic changes as processes reaching an equilibrium, view also criticized by other economists discussing influence of technology on economic changes (Nelson, Winter 1982). After this introduction the article contains

other three parts. The second one presents the model of technology. We have chosen to present the model in a descriptive way as in most applications we treat in this work it is not necessary to use its mathematical aspects. However, for reason of completeness, we have reported in the annex the mathematical model of technology for scholars would be interested on these aspects of the model. This second part presents definitions and concepts derived by the mathematical model such as structure of technology, technological space and space of technologies, efficiency of a technology and its technology landscape and concepts of intranality and externality of a technology. In the third part we treat some applications of the model to the innovation process by discussing the role of the radical degree of a technology in technological competitiveness, the existence of various ways to carry out technological innovations and giving a certain number of important real examples of application of the model to real cases. Finally the fourth part presents the conclusions and further possible studies based on this model.

2. THE MODEL OF TECHNOLOGY

2.1 Definition of technology

In our model we consider technology as an activity satisfying a human purpose generally exploiting new phenomena discovered by science through a new combination of pre-existing technologies (Arthur 2009). From the scientific point of view a technology is seen as an application

of research results useful also in finding optimal conditions in technological search (Fleming, Sorenson 2004). From the technological point of view in our model technology may be considered simply as an activity making a product.

2.2 Structure of the technology and the technological space

The model sees a technology as a structured set of technological operations, for example a heat treatment technology may be seen as a set of operations of heating, maintaining at a certain temperature, and cooling. Such description, however, is not rigidly established and in modelling we may use a more or less detailed set of operations giving a gross or fine description of technology depending on the purpose of use of the model. That is possible because technological operations have themselves the nature of a technology. As operations are carried out in a certain temporal sequence, the description of a technology may be improved by considering a graph structure in which nodes are represented by events of starting and/or ending of operations, and arcs, oriented with time, representing the various operations of a technology. This representation is analogous to what it is used in the PERT method for project management in which the events represented by nodes are connected through oriented arcs constituting the tasks of the project. For example, in the production of faucets and valves, the technology is composed by a structure of operations such as production of brass ingots or bars, hot stamping, casting, machining, finishing,

chroming, etc. and a simplified representation of this technology in form of graph is reported in Fig. 1. This graph is composed by a total of nine operations partly in sequence and partly in parallel. Each of these operations may be detailed and, for example, chrome plating operation is in fact composed by sub-operations such as degreasing, deposition of nickel followed by deposition of chrome. Definition of the operational structure of a technology is however not sufficient for the model, and we have to consider that operations are controlled by a certain number of parameters and that it is necessary to give instructions to establish particular values and choices to these parameters. Such parameters, in the case of the cited heat treatment technology, may be for example final temperature, heating velocity, maintaining time and cooling velocity. The model considers values or choices of parameters as a discrete set in a determined range. The whole set of parameters values or choices correspond to a set of *technological recipes* that may be considered in operating a technology (Auerswald, Kauffman, Lobo, Shell 1998). Specific choice of parameters values for each operation constitutes then a configuration or recipe of the technology and, by combinatory calculation, we can obtain the whole number of configurations or possible recipes existing for the modelled technology. All the configurations of a modelled technology may be represented mathematically in a multidimensional discrete space in which each point represents a specific recipe of the technology. Such space is called *technological space*. In this space it is

possible to measure the similarity of recipes by the Hamming distance between two points, or recipes, of the space. Hamming distance is defined in discrete mathematics and information theory as the minimum number of substitutions in the elements of a string to change the string into another of equal length. That corresponds in our case to the number of changes we shall introduce to make identical two technological recipes. Higher is the Hamming distance, lower is the similarity of recipes.

2.3 Space of technologies

Technological space is useful to describe a single technology with a defined operations structure. However, when discussing of various technologies, for example studying technological competition and evolution, it may be useful to have a space representing all considered technologies. Technology has been defined as an activity able to fulfil a specific human purpose (Arthur 2009), by consequence we can consider the existence of a set of technologies able to fulfil *the same* human purpose. It will be of interest to represent this set of technologies in a space in which it is possible to describe technology evolutions and evaluations of differences between technologies that are in competition for the same purpose. Technologies cannot be described by a simple combination of operations because, as we have seen previously, they have a specific time-oriented structure that can be represented by a graph. From the mathematical point of view a graph may be considered also in term of a matrix. There is then the possibility to describe a technology

as a matrix, using that to define a space similar to the technological space, in which each point represents a technology with its specific structure of operations, and called *space of technologies*. Such matrices shall of course take account of all types of operations included in all technologies having the same purpose and considered for a defined space of technologies. In this case, differently from the technological space, the Hamming distance among points is defined comparing matrices and not configurations. Such distance in the space of technologies increases with the difference between two technologies and may be considered a measure of the *radical degree* of a new technology compared to a pre-existent technology or alternative new technology. Following a largely used terminology a technology may be considered by the model *radical*, if this distance is great, or *incremental*, if this distance is small. At the same time a technological innovation may be considered radical (drastic) if the change necessary to transform a pre-existing technology into the new technology is great, or incremental (evolutive) if this change is small. In this way the space of technology defined by the model offers a special view of what it has been defined as natural trajectories of technical progress (Nelson, Winter 1977) in the frame of technological paradigms (Dosi 1982). In this space it is possible to represent the appearing with time of new technologies, of incremental or radical nature, depending by their radical degree, in terms of points of the space of technologies. In the case of appearance of a new radical technology there will be a transition in the space of technologies, due to the great

Hamming distance, from a group of incremental technologies originated possibly by a previous radical technology. In other words when an important radical technology appears in the space of technologies, it follows, as observed by Kauffman and reported in the introduction of the paper, an explosion of creativity generating a high number of dependent incremental technologies and at the same time there is the mass extinction of previous less efficient technologies including technologies that are directly dependent. Such explosion of creativity has been shown indirectly by studying the growth of number of dependent patents from an initial radical invention as in the case of computer tomography (Valverde, Solé, Bedau, Packard 2007).

2.4 Efficiency of technologies

Technology efficiency (fitness) is a complex concept that is difficult to define quantitatively by a unique description. From the practical point of view there are many types of efficiency that may be considered. For example, it is possible to consider energy efficiency of a technology in terms of production of energy but also on the contrary in terms of minimization of its consumption. It is also possible to define an environmental efficiency of a technology in terms, for example, of level of abated pollutants as well as in terms of level of purity, accuracy etc. One of the more important efficiency of a technology concerns its economy and may be expressed in terms of cost of production. From the point of view of the model it is possible to define an overall efficiency of a specific

recipe of a technology but also an efficiency of particular operations with specific values for their parameters. For practical use of the model it is useful to choose a mode of calculation of efficiency in such a way that the overall efficiency results of the sum of values concerning the efficiency of the various operations. For example, in a technology of production of energy there are operations that have a positive efficiency generating energy and operations with negative efficiency consuming energy and the overall efficiency corresponds to the sum of positive and negative values related to efficiency of the various operations. In the case of economic efficiency we should conveniently express efficiency in terms of costs that should be minimized and overall cost of a technology will be in fact the sum of costs of the various operations.

2.5 Technology landscape

From the point of view of the model the efficiency depends on the considered recipe. As the whole set of technology recipes is the result of a simple combinatory calculation, certain recipes will be absurd and have null or negative efficiency and others positive efficiency. Considering that all recipes may be represented by points in the technological space, we may associate to each point or recipe a scalar value of efficiency obtaining, by mapping this space, a fitness landscape that is called *technology landscape* (Auerswald, Kauffman, Lobo, Shell 1998). Such landscape is characteristic of the specific structure of operations characterizing the modelled

technology and the defined type of efficiency.

Exploring a technology landscape, we may find regions with recipes with nearly null efficiency and other regions with recipes with high values up to optimum values of efficiency. The landscape may present in certain cases only an optimum of efficiency at the top of a single “hill” of the landscape or have cluster of “peaks” of efficiency or even a rugged structure of high number of “peaks” with roughly the same efficiency. In a technology landscape the innovation process may be seen as an exploration searching of an optimal “peak” of efficiency for the technology. In Fig. 2 we have given a schematic view of a technological landscape consisting in a cluster with “peaks” of high or low recipe efficiency.

In this figure the multidimensional technological space has been simplified and points arranged on a bi-dimensional surface for a three-dimensional graphic representation. The model, through the space of technologies and the technology landscape, is in measure to describe a technology innovation process as an exploration of both spaces, looking for an optimal structure of operations and corresponding optimal values of parameters of operations.

It should be noted that, as the efficiency (fitness) of a technology is determined by the chosen recipe and not by the structure of the technology, it is not possible to map a landscape starting from the space of technologies, and each point of this space corresponds in fact to a specific technological space and landscape.

2.6 Intranality and externality of a technology

It should be noted that in practice the efficiency of an operation, and consequently of the technology, may be influenced not only by its specific instructions but also influenced by changing instructions of other operations. For example in a heat treatment technology the elimination of a defect appearing above a certain temperature may be avoided decreasing the temperature reached during the heating operation. However such lower temperature might not be enough high for the treatment and in this case the maintaining time should be increased to conserve a high efficiency for the technology. The interactions existing among efficiency of various operations is called *intranality* of a technology (Auerswald, Kauffman, Lobo, Shell 1998).. Such effect is important in optimizing technology efficiency that shall be achieved by a tuning work of the various parameters in the search of an optimal recipe. Existence of intranality effects does not allow an independent optimization of efficiency of single operations in improving the overall efficiency of the technology. From the mathematical point of view it is possible to show that a single optimal “peak” in a technological landscape is possible only in absence of intranality effects. In presence of intranality effects the landscape tends to have clusters of “peaks” and, when these effects are very numerous, the landscape assumes a rugged aspect with a high number of “peaks” with roughly the same efficiency (Kauffman, Lobo, Macready, 1998). Similar intranality interactions exist

also among operations of a technology during the search of an optimal structure of a technology. It may be observed for example, during introduction of a new operation in a production process, it might be necessary changes in other operations of the process and that may be acceptable or not. Operations efficiency as well as technology efficiency can be also influenced by external factors or variables that constitute the *externality* of the technology. External variables or factors may be for example: new raw materials characteristics, differences in type or composition of used products, various requirements in quality or types of certifications that should be satisfied by a product, etc. As in the case of operations, the externality of a technology may be seen as a set of factors each characterized by a certain number of parameters assuming a discrete number of values or choices in a certain range. Modelling of externalities, as in the case of technological operations, generates a certain number of configurations. Each configuration, because of its influence on efficiency, is linked to its specific technology landscape. Consequently, in developing a new technology, and in searching a correspondent optimal recipe, taking account at the same time of intranality and externality effects, it is necessary to consider not only the space of technologies but also a set of technology landscapes depending on the considered external configurations, as well as the various types of efficiency (fitness) for the technology that defines the types of technology landscape. These last considerations well show the complexity of the innovation

process, that, following the model, it may be considered as an exploratory adaptive walk in the space of technologies and in a certain number of technology landscapes, in searching of an optimal structure and recipe for a new technology, sometime necessitating also a trade off among various types of efficiency that shall be considered, as for example between minimum cost and respect of a certain level of environmental efficiency.

Finally it should be considered that for the model the fact that an operation will be associated to an intranality effect or a factor to an externality effect depends on the chosen structure for the technology. In fact, in certain cases, externality factors may be represented by operations and eventually included in the technology structure and generating intranality effects and vice versa, as we will see later discussing applications of the model.

3. APPLICATION OF THE MODEL TO THE INNOVATION PROCESS

Main applications of the model use the definition of the radical degree of a new technology in order to determine the technological competitiveness that, combined with the operational structure of the technology, may define various ways to obtain new technologies.

Other applications concern the effects of technology intranality on innovation developments. Minor applications concern the use of operations structure of a technology in technology assessment, space of technologies and technological space in patent intelligence studies and technology landscape for experimental planning.

3.1 Technological competitiveness

Competitiveness of firms is influenced by many factors concerning strategies, production, marketing, etc. However, in certain cases, technology aspects may become important for firm's competitiveness determining or not its success. The model may give explanations about the origin of technological competitiveness considering the operational structure of a technology and its radical degree. Aspects that shall be considered are the necessary competences associated to operations composing a technology. These competences, necessary to technology use, may be more or less available, or taking time to obtain, in the frame of a process of technology innovation. Considering for example the technological situation existing in an industrial district, or in an industrial sector, making the same type of products, all firms have approximately the same competences necessary to carry out the production. If a firm of an industrial sector or district improves its technology by optimizing parameter values and by minor changes in technological operations, it may obtain a certain technological advantage. However, the obtained new technology has generally a low radical degree, typical of incremental innovations, and probably requiring competences that are not far and easily available to a competing firm. By consequence this firm would not have major difficulties to also improve its technology eliminating in this way the previously formed technological advantage. Furthermore an incremental innovation may be not necessarily patentable or it may result probably in a weak patent that may be easily countered by the concurrent firm. As

incremental innovations are continuously introduced in the activity of firms, this fact leads to a situation called *Red Queen Regime* in which the production technologies are continuously improved but assuring simply survival and not development of a firm in respect to the others ones.

Red Queen Regime is a term used originally in description of genetic competition between preys and predators (Van Valen 1973) and Red Queen is a character of Lewis Carroll's "Through the looking glass" continuation of "Alice's Adventures in Wonderland" that tells to Alice "In this place it takes all the running you can do, to keep in the same place". Another situation of Red Queen Regime may be found considering diffusion of an available new technology in an industrial sector.

Firms acquiring early the technology obtain a competitive advantage that however disappears after other firms also acquire the technology. An indication of a diffused existence of Red Queen Regimes might be also indicated by studies concerning values of patents, and indirectly of technology innovations (Scherer, Haroff 2000).

These authors studied the distribution of value of various samples of patents the greatest concerning 772 German patents hold valid for at least ten years. They found a skew distribution with a very small number of patents with a very high value and a great majority of patents with low value. In fact about 25% of 772 patents have negligible values, thousand times lower than the five patents with the highest values.

It could be argued why a so high number of patents, with very low value, have been nevertheless maintained valid for at least ten years. It might be advanced that maintaining of protection of low value patents might be useful in holding sufficiently competitive technological positions in a Red Queen Regime.

On the contrary if a firm develops a new technology with a high radical degree, this new technology will be characterized by important modifications in the technological operations, and it will be very probable that one or more operations will be so different to be extraneous to the existing competences of the other firms in competition. Such firms would be forced to take time and make efforts in acquiring new competences and know how to become again competitive.

It should be observed, of course, that technological advantage is not dependent only by number of changed operations but also by their more or less availability or difficulty to develop them in term of competences. Furthermore it will be probable that a new radical technology could be protected by strong patents that will add further important difficulties in recovering competitiveness by the other firms. A conclusion derived by such discussion is that a general industrial strategy diffused in a district or industrial sector, based essentially on incremental innovations, is not free from danger in the case of appearance of a new radical technology destroying competitiveness of per-existing technologies.

A remarkable example of such situation was the case of Swiss watch industry in the middle of the seventies of the past century

threatened by an emergent Japanese watch industry based on piezoelectric properties of quartz and liquid crystal technology instead of the traditional mechanical technology.

Swiss watch industry was composed in the seventies by a great number of SMEs, organized as an industrial district in the north west of the country, and using mechanical technologies for watches production. Innovations were essentially incremental and industries operate in a typical situation of Red Queen Regime. Although the use of quartz piezoelectricity in watches was known, it was applied only to a limited number of luxury models and Swiss industry considered this technology expensive and not competitive with their excellent traditional mechanical production. The possibility of production of low cost electric watches was instead considered by Japanese industry that oriented technical developments in a radical direction using quartz piezoelectric oscillations instead of traditional mechanisms, a digital indication of hours using liquid crystals, a material that change its luminosity as a function of applied voltage, and introducing a small battery supplying energy to the watch. This product had a relatively low price and reached a great success in the market putting in great difficulties the traditional Swiss watch industry and, at the end of the seventies, about 40% of Swiss watch firms disappeared. Survival and restarting of Swiss watch industry was due essentially to the action of Nicholas Hayek that organized the merging of many watch firms in the SMH holding, and developed a new watch concept, the SWATCH®, based

technologically on a low cost quartz system with a technology industrialization that lasted about four years. Swiss watch industry did not have any liquid crystal technology and practically never used digital indications of hours in its models.

The history of survival and new expansion of Swiss watch industry shows how it was important to have available, although not still used industrially, a new technology based on quartz, and how was important the development of a new product concept combining both analogical indication of hours and use of watch as an ornamental accessory. It should be noted that radical innovations in conventional technology field are relatively rare and a firm, using technology innovation for development, has also available a strategy of continuous and fast development of incremental innovations conserving continuously the technological gap and competitiveness. However, this strategy of continuous incremental innovation might have, nevertheless, statistically diminishing returns becoming with time less effective in conformity with behavior of the typical experience curves (Wright 1936).

3.2 Types of technology innovation activities

The model sees technological innovations in term of technological changes of the structure or of operations parameters values of a previous technology. For the model the simple change of operations parameters does not constitute a real technology innovation that is characterized in fact by changes in used operations and structure.

However the model attributes a similar nature to various types of technology innovations and in particular for example to R&D and learning by doing in the measure that the last may involve also some minor changes by eliminating, adding or substituting operations, changing the previous technology landscape. Considering learning by doing with its original definition as shop floor work, increasing manufacturing experience, leading to a positive macroeconomic production externality independently of bringing additional capital or work and even R&D investments (Arrow 1962), the model sees learning by doing as a type of innovation process, characterized by a low radical degree, leading possibly to an incremental new technology.

Considering now a new technology, with a high radical degree, it may be obtained normally by R&D activities. In this case we have to take account of the nature of innovations based on exploitation of phenomena discovered by science through a combinatory process of pre-existing technologies (Arthur 2009).

However, as the radical degree of an innovation depends essentially by operations and structure change of a previous technology, but not necessarily by exploiting phenomena discovered by science, it could be argued that an innovation with a high radical degree, and then competitive, might be obtained also by a simple combinatory process of pre-existing technologies without any exploitation of phenomena discovered by science.

In fact there are many examples of important innovations that were not

developed by exploitation of scientific results and, concluding, it is possible to define by the model, three types of innovation activities reported below:

Scientific development of applications: an activity of technology innovation based on exploitation of new or never exploited phenomena. It is characterized by radical changes related to the combinatory process changing the nature of operations and structure of a technology.

Combinatory development of applications: an activity of technology innovation based on a combinatory process of pre-existing technologies. It is characterized by radical changes related to the combinatory process changing the nature of operations and structure of a technology without exploiting new phenomena.

Learning by doing: an activity of technology innovation for improving a technology and facing externalities affecting the efficiency of the technology. It is characterized by search of optimal conditions for parameter values of the various operations and minor changes in the nature and/or structure of the technological operations.

In order to illustrate in particular the difference between new important technologies obtained by exploitation of scientific phenomena or by simple new combination of pre-existing technologies we may consider the case of invention of photocopy and that of personal computer (PC). The invention of photocopy is a typical innovation based on exploitation of

the physical phenomena of photoconduction described below:

Photocopy was invented by Chester Carlson in the thirties of the past century and development financed by the Battelle Development Corporation, a division of the Battelle Memorial Institute as reported in the history of Battelle (Bohem, Groner, 1972). His central idea was to exploit the photoelectric phenomena existing in certain materials, in form of photoconductive film, exposed to light in such a manner to reproduce, for difference of charges, an image attiring fine carbon powders that may be used to print a paper page. Photoconductive properties of materials were discovered in the last decades of XIX century and Chester Carlson was probably aware about these phenomena during his studies in physics at the California Institute of Technology. He made experiments in his own kitchen with good results sufficient to obtain a valid patent in 1937. After a period of interruption because of the war, in 1944 Carlson signed an agreement with the Battelle Development Corporation for the development of the invention by R&D activity in Battelle Columbus Laboratories. At the end of 1946 Battelle was in measure to make an agreement with Haloid, a medium sized company in the field of photographic paper, for the development and industrialization of the invention. At the end of the fifties Haloid succeeded in offering an automated model with a strong market development and becoming the present Xerox company.

Personal computer (PC) may be considered a typical combinatory

innovation without any direct exploitation of scientific results. Its origin and development results of efforts of many people and companies, however it is usual to cite the pioneering role of Apple and its founders Steve Wozniak and Steve Jobs.

The invention of PC may be attributed to Steve Wozniak and the combinatory process leading to this invention has been described in detail in the official biography of Steve Jobs (Isaacson 2011). Wozniak was at that time an electric engineer working at HP on electronics connecting a terminal constituted by a keyboard and monitor with a central minicomputer. Hobbyist in electronics, he frequented the Homebrew Computer Club. In one of meeting of this club discussing microprocessors, Wozniak had the idea to put in the terminal itself some capacities of the minicomputer using a microprocessor, making a stand-alone computer on a desktop, in fact a PC. Immediately Wozniak worked on realization of needed circuits succeeding to connect a keyboard input giving a wanted output on a screen on Sunday, June 29, 1975, a milestone for PC. After that, with his friend Steve Jobs, founded Apple in 1976. The product was simply a motherboard, that may be connected to a typical keyboard, similarly to that used in electric typewriters, and a domestic TV apparatus as presented in Fig. 3. Steve Jobs may be considered the person that understood fully the potentiality of Wozniak machine as a product, easy to use, inexpensive, interesting people in general and not only professionals or hobbyists. In fact before Apple there were other desk computers, such as HP 9100 in 1968, the

first being Olivetti P101 in 1964, invention that in fact exploited magnetostriction phenomena to reduce memory storage volume, but they were expensive products addressed to professionals. In the case of Apple innovation components were arranged following a functional computer structure called Von Neumann architecture, known since 1944. Exploitation of new phenomena had been present only in used commercial components, such as for example the use of transistor effect discovered in 1925 and the possibility to use silicon as solid transistor discovered in 1948.

In addition to the example of combinatory innovation such as PC, we report here another radical combinatory invention as example of technological innovations existing in Italian industrial districts and explaining the apparent paradox of an innovative SMEs industry not related to scientific research activity (Hall, Lotti, Mairesse 2009). That is the case of Moka Express® a coffee-maker in competition with a pre-existing coffee-maker called Napoletana. The different design concepts of both coffee-makers are illustrated in Fig. 4 and details on generation of innovation are given below:

Moka Express® was invented by Alfonso Bialetti and the history of this invention has been reported in detail in a commercial promotion booklet of his company (Bialetti 1995). He emigrated in France at the beginning of the XX century and came back to Italy in 1918 with experience in aluminium casting opening a small mechanical workshop. He invented the new

coffee-maker at the beginning of thirties starting production in 1934. It is remarkable that Moka Express design was not derived by a new combination of elements of other existing coffee-makers but by a pot used in washing laundry in which boiling water comes through a tube from separated heated bottom of the pot. Differences from Napoletana coffee-maker were not only in design but also in material, aluminium instead of copper sheet, and fabrication, aluminium pressure molding instead of welding. After the war his son Renato Bialetti developed the product with a successful marketing effort expanding sales not only in Italy but also abroad while production of Napoletana coffee-maker disappeared.

Moka Express® may be considered also a good example of radical combinatory development based on technologies not necessarily belonging to the same technological sector.

3.3 Effects of technology intranality on the innovation process

As we have seen previously intranality of a technology has been defined in the Kauffman's model the effect on efficiency by changing parameters of an operation on the other operations of a technology. By consequence, intranality effects make necessary a tuning work on various parameters in order to obtain the maximum of efficiency of the entire technology. Such intranality effect exists also in the case of change of operations in the frame of innovation of a technology. Such change may in fact affect the efficiency of other

operations used in the technology. Such effects are normally controlled in the frame of an innovation process carried out in a firm that performs all the involved technology operations. However, when the development of a new technology is carried out through a collaboration of a group of firms, it is important that this group can assure all needed competences and interest in developing the new technology in order to take account of the operational intranality effects (Rolfo, Bonomi 2014). The situation is different when an innovation is developed typically in industrial districts in which many operations are subcontracted to external firms. In this case a subcontractor should modify its operations because of the introduced innovation by one of his clients. That might be not accepted because of necessity of additional investments or incompatibility with work made for other clients with the consequence that innovation could not enter in use. Such type of intranality effects have been observed for example in a study of the innovations processes occurring in the Italian industrial district producing ceramic tiles in which a new product or production process developed by a firm, but needing complementary innovations by other firms to be used, may be adopted only if it generates a sufficient demand to interest the firms that should introduce the complementary innovations (Russo 2003). It should be noted that negative effects of intranality are easily overtaken in Silicon Valley, where large parts of productions are subcontracted abroad, carrying out innovations by sharing costs and risks of the development of new products with partners and suppliers (Saxenian 1994). In

order to illustrate a detailed example of intranality effects by operations we may consider the case of production of a lead free brass in the technology of fabrication of valves and faucets that have the operational structure reported in Fig. 1.

In the sixties in USA and in other countries were introduced strict norms about contamination of drinking water by heavy metals, in particular lead. Valves and faucets are in fact made using a lead containing brass in order to improve the machining speed, but normal content of lead would contaminate water in certain cases above the limits of the norms. Solutions were the use of a treatment able to eliminate the lead existing on the surface of brass, or to develop a new lead free, easy machining, brass alloy. Such last solution was developed by an important German producer of brass with an alloy called ECOBRASS®. Unfortunately such alloy contained silicon giving problems to the chroming operation that would necessitate a further bath treatment to eliminate silicon from the surface. However such additional treatment was expensive and the bath was difficult to handle because very aggressive. In this situation only producer of valves that do not carry out any chroming operation might use ECOBRASS®. In fact, because of the cost of this alloy, many producers of valves and faucets tried to modify their machining operation in order to obtain acceptable speeds at low cost with simple free lead brass, or use an additional operation consisting in a simple special treatment to eliminate the lead on the surface of the brass. The various previously described aspects of possible solutions

concerning the production of lead contamination free valves and faucets have been reported in a study on demand of R&D activity of Italian SMEs (Bonomi 2013).

We may note the source of intranality effect is the lead free brass production resulting of operation 1 of Fig. 1. However, lead free brass may be considered also in term of an externality effect if we consider the technology structure starting with operations 2 and 3 of Fig.1. In this case lead free brass bars and ingots are simply considered as raw materials used by the technology. This example confirms the already cited interchangeability between intranality and externality effects existing in certain cases and depending on adopted structure for modeling a technology.

3.4 Other applications of the model

An interesting application of the model may be found considering the various operations composing the structure of a technology. For example in a study on technology assessment concerning various urban waste treatments it was studied a technology called Thermoselect (Bonomi, 2001). This technology was a complex combination of operations from coal gasification technology, used in the past in chemical industry, and from various types of technologies existing in steelmaking. Study on Thermoselect showed the existence of various development difficulties on the base of knowledge of previous technologies and their interactions. In fact, a demonstration plant built in Karlsruhe failed because of difficulties especially in the cleaning gas operation,

that, in the case of gas from coal gasification technology, normally feeds chemicals reactors, while gas from waste gasification were more contaminated and unsuitable, also after cleaning, to feed Diesel motors for electricity production. For this reason Thermoselect technology was later abandoned. Space of technologies and technological spaces may be useful in the case of patent intelligence studies looking for protected or free patentable conditions. In fact claims and examples reported in a patent may correspond to regions of these spaces that may be considered in such studies. Finally the technology landscape of the model may be used in planning a minimal number of experiments necessary to find optimal conditions, taking also account of intranality and externality effects on the technology efficiency. That was the case of planning experiments for search of optimal conditions for a surface treatment technology eliminating lead from brass surface (Bonomi, Riu, Marchisio 2007).

4. CONCLUSIONS

The novelty of the model described in this article lies in its origin from analogies between technology and biology evolution, allowing an interpretation on how a new technology is born through a process forming a structure based on technological operations. That opens a description of a technology in term of technological spaces and landscapes, as well as in spaces of technologies, in which it is possible to represent evolutive paths of technologies, changes in their efficiency and measure of their radical degree linked to their

technological competitiveness. On the other side the various types of changes in the technology structures may define different types of innovation processes. The model may explain the existence of continuous technological improvements not accompanied by any economical development in firms characterized by similar productions in what it is called a Red Queen Regime. Such regime may be disrupted by the entering of technologies with a high radical degree. The model may also explain the paradox of existence of technologically innovative firms not resorting to results of scientific research. The model has been found useful also in management of technology innovations in fields such as technology assessment, patent intelligence and planning of experiments. Further studies might involve an in depth study of R&D activity from a technological point of view in which technology is not considered as a simple economic good, but rather as an available activity with economic implications emerging by an ecosystem evolving similarly to a biologic ecosystem.

BIBLIOGRAPHY

- Altenberg L. 1996, *NK Fitness Landscape*, Section B2.7.2 in *The Handbook of Evolutionary Computation*, ed. T. Back, D. Fogel, Z. Michalewicz, Oxford University Press
- Arrow K.J. 1962, *The economic implications of learning by doing*, *Review of Economic Studies* 29, pp. 155-173
- Arthur B. 2009, *The Nature of Technology* Free Press, New York
- Auerswald P. Kauffman S. Lobo J. Shell K., 2000, *The Production Recipe Approach to Modeling Technology Innovation: An Application to Learning by Doing*, *Journal of Economic Dynamics and Control*, 24, 389-450
- Basalla G. 1988, *The Evolution of Technology*, Cambridge University Press
- Bialetti S.p.A. 1995, *I Segreti del Caffé*, DE & CO Immagine e Comunicazione, Milano
- Boehm G. Groner A. 1972, *Science in the Service of Mankind: the Battelle Story*, Lexington Books
- Bonomi A. 2001, *Selezione di tecnologie appropriate per lo smaltimento dei rifiuti urbani*, Atti dei Seminari di RICICLA 2001, Rimini Fiera, September 26-29, 447-460
- Bonomi A. Riu A. Marchisio M. 2007, *Modelling Technologies for Experimental Planning*, Working Document available on www.complexitec.org Technology innovation section
- Bonomi A. 2013, *Domanda e Offerta di Ricerca & Sviluppo nella PMI Italiana. Due casi studio: il NISLabVCO e il Consorzio Ruvaris*, Rapporto Tecnico CERIS, Anno 8, n° 46
- Dosi G. 1982, *Technological paradigms and technological trajectories. A suggested interpretation of the determinants and direction of technical change*, *Research Policy*, 11, 147-162
- Fleming L. Sorenson O. 2001, *Technology as a complex adaptive system: evidence from patent data*, *Research Policy*, 30, 1019-1039
- Fleming L. Sorenson O. 2004, *Science as a map in technological search*, *Strategic Management Journal*, 25, 909-928
- Frenken K. 2001, *Understanding Product Innovation using Complex Systems Theory*, Academic Thesis, University of Amsterdam jointly Université Pierre Mendès France, Grenoble
- Hall B.H. Lotti F. Mairesse J. 2009, *Innovation and productivity in SMEs: empirical evidence for Italy*, *Small Business Economy*, 33, 13-33
- Isaacson W. 2011, *Steve Jobs*, Simons & Schuster, New York
- Kauffman S. Levin S. 1987, *Toward a general theory of adaptive walks on rugged landscapes*, *Journal of Theoretical Biology*, 128, 11-45
- Kauffman S. 1993 *Origins of Order: Self-organization and Selection in Evolution* Oxford University Press
- Kauffman S. Lobo J. Macready G.W. 2000, *Optimal Search on a Technology Landscape*, *Journal of Economic Behaviour and Organization*, 43, 141-166
- Lobo J., Macready G.W. 1999, *Landscapes: A Natural Extension of Search Theory*, Santa Fe Institute Working Paper, 99-05-037

- Nelson R. Winter S. 1977, *In search of a Useful Theory of Innovation*, Research Policy, 6
- Nelson R.R. Winter S.G. 1982, *An Evolutionary Theory of Economic Change*, Cambridge MA & London: Belknap Press of Harvard University Press
- Rhodes R. 1986, *The Making of the Atomic Bomb*, Simons & Schuster Paperbacks, New York
- Rolfo S. Bonomi A. 2014 *Coopération pour l'innovation à niveau local: un exemple italien de succès*, Innovations, N. 44, 57-77
- Russo M. 2003, *Innovation processes in industrial districts*, ISCOM Project, Venice November 8-10, 2002, revised version 07.02.2003
- Saxenian A. 1994, *Regional Advantage*, Harvard University Press
- Scherer F.M. Haroff D. 2000, *Technology Policy for a World of Skew-Distributed Outcomes* Research Policy, 29 (4-5) pp. 559-566
- Strumsky D. Lobo J. 2002, "If it Isn't Broken, Don't Fix It" *Extremal Search on a Technology Landscape*, Santa Fe Institute Working Paper, 03-02003
- Valverde S. Solé R. Bedau M. Packard N. 2007, *Topology and Evolution of Technology Innovation Networks*, Phys. Int. Rev. E 76, 032767
- Van Valen L. 1973: *A New Evolutionary Law*, Evolutionary Theory 1, p. 1-30.
- Waldrop M. 1992, *Complexity, the emerging science at the edge of order and chaos*, Simon & Schuster, New York
- Wright T.P. 1936, *Factors affecting the cost of airplanes*, Journal of the Aeronautical Science, 2, 122-128

ANNEX

1.1 MATHEMATICAL MODEL OF TECHNOLOGY

A1. Technology

This mathematical model is derived by a previous model (Auerswald, Kauffman, Lobo, Shell 2000) employing a variant of the NK model originally designed for analysing asexual biologic evolution (Kauffman, Levin 1987 and Kauffman 1993). This model considers a technology as a set of technological operations. Each operation is characterized by a certain number of instructions or parameters and each parameter may assume a discrete number of values or choices in a certain range of variability. For example, a heat treatment technology may be composed by three operations: heating, maintaining in temperature, and cooling. Heating is characterized by parameters such as heating velocity and temperature that should be reached, maintaining characterized by maintaining time and maintaining temperature and cooling by cooling velocity. Each parameter may assume a certain number of values within a certain range. Technology, however, may be better described as a structure of operations represented by an oriented graph which nodes represent the starting/ending points of an operation and arcs the operations. This graph is similar to representation of tasks used by the PERT method in project management. A simple example of oriented graph structure for the heating technology constituted by three arcs in sequence and their associated parameters is presented as follows:

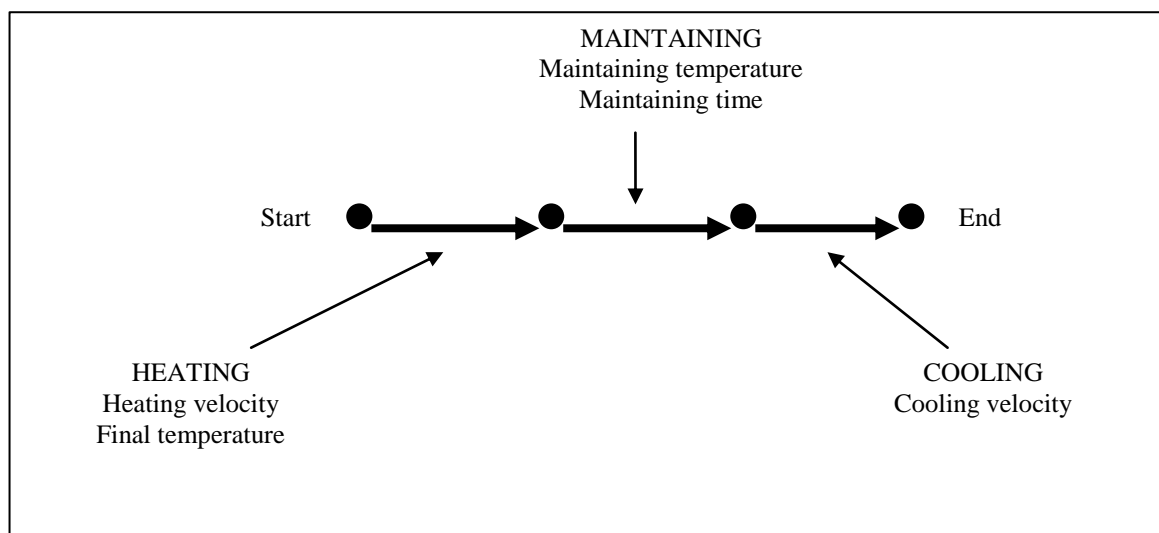

Following the model a technology may be defined by a set O composed by N operations:

$$O = \{o_i, i = 1, \dots, N\} \quad (1)$$

Each operation o_i is characterised by a set M_i of M_i specific instructions:

$$M_i = \{p_{ij}, i = 1, \dots, N ; j = 1, \dots, M_i\} \quad (2)$$

In which p_{ij} represents the j th instruction associated with the i th operation o_i . The total number P of instructions characterising a technology is given by:

$$P = \sum_{i=1}^N M_i \quad (3)$$

The instruction p_{ij} may assume a set S_{ij} of different values or choices:

$$S_{ij} = \{s_{jik}, i = 1, \dots, N ; j = 1, \dots, M_i ; k = 1, \dots, S_{ij}\} \quad (4)$$

in which S_{ij} indicates the cardinality of the set S_{ij} .

The N operations cannot be considered simply a set as in fact they have normally a specific temporal sequence that may be represented by an oriented graph. Indicating with E the set of events determining the start or/and ending of the operations and, as previously, with O the set of the operations we can build up a graph τ that we can call graph of the operations of the technology:

$$\tau = (E, O) \quad (5)$$

In which E represents nodes and O the oriented arcs of the graph. Differently from the previous model of production recipes (Auerswald, Kauffman, Lobo, Shell 2000), in our model we take into account that each operation can be associated to more than one instruction as in equation (2). For example, an operation such as heating in a heat treatment can be associated to an instruction as the final temperature but also to a specific velocity of heating. Being from equation (1) N the number of operations and from equation (3) P the total number of instructions we have:

$$P \geq N \quad (6)$$

When $N = P$ each operation is characterised by only one instruction.

A2. Technological recipes and technological space

Considering a specific technology with a set of N operations corresponding to a total of P instructions, we can define as *technological recipe* the specific configuration ω obtained attributing a specific value or choice to each of the P instructions. The set Ω of all the possible configurations of a technology is given by:

$$\Omega = S_{11} \times S_{12} \times \dots \times S_{1M_1} \times \dots \times S_{NMN} \quad (7)$$

In other terms we have:

$$\Omega = \{\omega_i, i = 1, \dots, \prod_{i=1}^N \prod_{j=1}^{M_i} S_{ij}\} \quad (8)$$

The number of configurations $|\Omega|$ is given by:

$$|\Omega| = \prod_{i=1}^N \prod_{j=1}^{M_i} S_{ij} \quad (9)$$

Should be $S_{ij} = S$, $i = 1, \dots, N$ and $j = 1, \dots, M_i$ we have:

$$|\Omega| = S^P \quad (10)$$

We may note that the number of configurations varies exponentially along with the number of values or choices for the instructions and even with a small number of instructions the number of technological recipes is very high.

In order to better explain the previous equations we may illustrate a simple example considering a technology with the number of operations $N = 2$ and then:

$$O = \{o_1, o_2\}$$

Should for example operation o_1 a heating and operation o_2 a cooling we have:

$$M_1 = \{p_{11}, p_{12}\}$$

Where the operation of heating is associated to $M_1 = 2$ instructions such as p_{11} as the final temperature and p_{12} as the velocity of heating. At the same for the operation o2 of cooling we may have:

$$M_2 = \{p_{21}\}$$

Corresponding to a free cooling to a final temperature indicated by instruction p_{21} . Now considering there are two possible heating temperatures and only one value of velocity of heating we have:

$$S_{11} = \{s_{111}, s_{112}\}; S_{11} = 2$$

$$S_{12} = \{s_{121}\}; S_{12} = 1$$

At the same time should be two the final cooling temperatures we have

:

$$S_{21} = \{s_{211}, s_{212}\}; S_{21} = 2$$

The number of configurations ω present in the set Ω will be four:

$$|\Omega| = S_{11} \cdot S_{12} \cdot S_{21} = 2 \cdot 1 \cdot 2 = 4$$

These configurations or technological recipes may be represented as:

$$\omega_1 = (s_{111} s_{121} s_{211})$$

$$\omega_2 = (s_{111} s_{121} s_{212})$$

$$\omega_3 = (s_{112} s_{121} s_{211})$$

$$\omega_4 = (s_{112} s_{121} s_{212})$$

We may also define a Hamming distance d among the recipes as the minimum number of substitutions to be made to transform a recipe ω into ω' . This operation is symmetric and we have:

$$d(\omega, \omega') = d(\omega', \omega) \quad (8)$$

In the same manner we may define the set N_δ of neighbours of a recipes $\omega \in \Omega$ defined as the number of configurations ω' existing at distance δ from ω as follows:

$$N_\delta(\omega) = \{\omega' \in \Omega \mid d(\omega, \omega') = \delta\} \quad (9)$$

The space in which it is possible to represent all the technological recipes through the reciprocal Hamming distance can be called *technological space*. The dimensionality of this space is given by number of neighbours $|N_\delta|$ for distance $\delta=1$. Considering that each of the P instructions is characterised by S_{ij} values or choices the dimensionality of the technological space will be:

$$|N_{\delta=1}| = \sum_{i=1}^N \sum_{j=1}^M (S_{ij} - 1) \quad (10)$$

Should the instructions have all the same number S of values or choices the dimensionality of the technological space will become:

$$|N_{\delta=1}| = (S - 1)P \quad (11)$$

In this case the geometrical representation of the technological space becomes a hypercube of dimension $|N_{\delta=1}|$

A3. Space of technologies

Technological space is useful to describe a single technology with a defined operations structure representing all the configurations or recipes that this technology can assume following its model. When discussing of various technologies, for example studying technological competition and evolution, it may be useful to have a representation space for all technologies. This representation can be obtained considering a family of technologies defined as able to fulfil the same specific human purpose (Arthur 2009). In order to describe a space of a family of technologies it is necessary to define a distance among the various technologies taken into consideration. Technologies cannot be described by a simple combination of operations because they also have a time-oriented structure that can be represented by a graph, and a graph can be mathematically represented in form of a matrix. Distances among technologies can be then defined in terms of distances among matrices. Let us consider a set (family) of technologies T involved for the same human purpose, for example writing, transportation, etc. Each technology belonging to T is characterised by M operations chosen from a set O of N different operations. It means that the same operations may be in certain cases repeated in the graph structure of a technology. Furthermore, some of the N operations can be also performed “in parallel” i.e. at the same time. Every technology $\tau \in T$ can be, hence, associated with a $M \times N$ matrix T whose elements, T_{ij} , can assume either the value 1 or 0. More precisely, $T_{ij} = 1$ if the j th operations is present in the M position on the graph g related to τ , otherwise $T_{ij} = 0$. At this point it is possible to establish a Hamming distance between any pair of technologies τ and τ' in T as the “difference” between their matrices T and T' :

$$d(\tau, \tau') = \sum_{i=1}^M \sum_{j=1}^N |T_{ij} - T'_{ij}| \quad (12)$$

By knowing all distances among the technologies of the family T we may build up, as in the case of technological recipes, a space that we may name *space of technologies*. Furthermore, it is possible to define a set N_δ of the neighbouring technologies of the set T that are between the distance δ as:

$$N_\delta(\tau) = \{ \tau' \in T \mid d(\tau, \tau') = \delta \} \quad (13)$$

The number of all the technologies τ present in a given family T is not univocally determined because it depends both on the type and on the “parallel” compatibility of the N operations. If, for instance, none of the N operations could be performed at the same time as another one in O , the cardinality of T would be simply given by N^M .

In the space of technologies the Hamming distance between two technologies may be used as definition of the *radical degree* of a new technology as a measure of the difference between a new technology and a pre-existing technology in competition. In other words new technologies that are at a short Hamming distance may be considered as result of evolutive or incremental innovations while new technologies that are at a long distance in this space may be considered as drastic or radical innovations (Nelson, Winter, 1977) in the frame of a technological paradigm (Dosi, 1982). Such trajectory, in the technology space defined by our model, may be seen as a path at short Hamming distances in periods of incremental innovations and transitions at high Hamming distance in presence of a radical innovation of a technology. In our model technological space and space of technologies represent the exploration spaces for the development of a technology innovation.

A4. Efficiency of technologies and technology landscape

Technology efficiency is a complex concept that is difficult to define quantitatively in univocal terms. Technology efficiency for example in term of energy, abated pollutants, etc. can be measured quantitatively only defining its specific aspects. An important type of technology efficiency is the economical efficiency that can be measured for example as the inverse of unitary cost of production. Relations between two types of efficiency may be established and particularly important are relations between the various types of efficiency with economic efficiency. The efficiency of a technology is strictly dependent on the particular used recipe. Certain recipes may have practically zero or negative efficiency but other recipes may have high efficiency and constitute an optimum. As previously reported, associating to all recipes of the

technological space the corresponding value of efficiency we obtain the mapping of this space. Indicating with Θ the corresponding value of efficiency to a specific recipe ω of set Ω :

$$\Theta: \omega \in \Omega \rightarrow \mathbb{R}^+ \quad (14)$$

This mapped space is called *technology landscape* and it is characteristic of the specific structure of operations and instructions constituting a technology and depending of course of the used definition of efficiency. Exploring a technological landscape we will find regions with recipes with nearly zero efficiency and other regions with recipes with high values up to optimum values of efficiency.

The efficiency of a specific recipe is in general a function of the efficiency of the various operations constituting the technology. In our model we consider convenient to define operation efficiency or inefficiency in such a manner that the sum of single operation efficiency or inefficiency constitutes respectively the global efficiency or inefficiency of the recipe. Considering for example the efficiency θ_i of operation o_i , it will depend on values or choices s_{ijk} of its instructions p_{ij} but possibly also on values or choices of instructions of other operations o_l , $l \neq i$. The total efficiency $\Theta(\omega)$ of the technology with configuration ω composed by N operations is given by:

$$\Theta(\omega) = \sum_{i=1}^N \theta_i(o_i, o_l) \quad (15)$$

This calculating way of total efficiency of a recipe as sum of efficiency values of single operations is easy made in the case of technical efficiency such as energy, purity, pollution abatement, etc. In the case of economic efficiency if we define it as the inverse of cost of each operation the equation (15) is not valid as the sum of the inverse of operational costs does not give the total economic efficiency. In such case it is preferable to use directly the cost of operations the sum constituting the total cost of a recipe and optimal conditions in the technology landscape constituted by a minimum of costs. In such case the total economic efficiency $\Theta(\omega)$ of the technology with configuration ω composed by N operations will be given by:

$$\Theta(\omega) = 1 / \sum_{i=1}^N c_i(o_i, o_l) \quad (16)$$

The total cost C of the recipe by:

$$C(\omega) = \sum_{i=1}^N c_i(o_i, o_i) \quad (17)$$

It should be noted that in the cited former model (Kauffman, Lobo, Macready, 2000) there is a different definition of efficiency of a recipe as average of the sum of efficiency of the single operations.

A5. Intranality and externality of a technology

We have seen previously that the efficiency of an operation may be a function of the values or choices made for the instructions characteristic of the operation but possibly also by instructions of other operations existing in the recipe. That means if we modify values of parameters of an operation o_i , the efficiency θ_i of operation o_i will depend on values or choices s_{ijk} of its instructions p_{ij} but possibly also on values or choices of instructions of other operations o_l , $l \neq i$. This fact is defined as *intranality* of a technology. Such interaction has been already considered in technology landscapes of former models (Kauffman, Lobo, Macready, 2000) and defined using mathematically the NK model of interactions. In our model, differently of the former one, we consider the possibility to have more than one instruction for each operation corresponding to a more generalised NK model (Altenberg 1996). Considering the limited purposes of our model we have not developed a mathematical definition of intranality based on a more generalized NK model.

Operations efficiency as well as technology efficiency can be also influenced by external factors or variables that constitute in our model the *externality* of the technology and that should be taken account in our model. External variables may be constituted for example by raw materials characteristics, differences in type or composition of used products, various requirements in quality or types of certifications that production should satisfy, etc. As it has been previously done in the case of values or choices for instructions we may take in considerations various parameters for external variables forming specific external configurations in which the technology should operate. Consider the set V composed by B external variables v_i :

$$V = \{v_i, i = 1, \dots, B\} \quad (18)$$

Each external variable v_i is characterised by a set R_i of R_i specific parameters:

$$R_i = \{q_{ij}, i = 1, \dots, B ; j = 1, \dots, R_i\} \quad (19)$$

Where q_{ij} represents the j th parameter associated with the i th external variable v_i . The total number

Q of parameters characterising an externality is given by:

$$Q = \sum_{i=1}^B R_i \quad (20)$$

The parameter q_{ij} may assume a set F_{ij} of values or choices:

$$F_{ij} = \{f_{jik}, i = 1, \dots, B; j = 1, \dots, R_i; k = 1, \dots, F_{ij}\} \quad (21)$$

In which F_{ij} indicates the cardinality of the set F_{ij} .

Considering a specific externality with a set of B variables corresponding to a total of Q parameters, we can define as specific externality the specific configuration γ obtained attributing a specific value or choice to each of the Q parameters. The set Γ of all the possible configurations of an externality are given by:

$$\Gamma = F_{11} \times F_{12} \times \dots \times F_{1R_1} \times \dots \times F_{BRB} \quad (22)$$

In other terms we have:

$$\Gamma = \{ \gamma_i, i = 1, \dots, \prod_{i=1}^B \prod_{j=1}^{R_i} F_{ij} \} \quad (23)$$

the number of configurations $|\Gamma|$ will be given by:

$$|\Gamma| = \prod_{i=1}^B \prod_{j=1}^{R_i} F_{ij} \quad (24)$$

Should be $F_{ij} = F$, $i = 1, \dots, B$ et $j = 1, \dots, R_i$ we have:

$$|\Gamma| = F^R \quad (25)$$

We may note that the number of configurations of external variables also corresponds to the number of technology landscapes existing for the technology operating under the influence of a

defined configuration of external variables. Finally it is important to consider the value G resulting by:

$$G = |\Gamma| * |\Omega| \quad (26)$$

$|\Omega|$ represents the number of possible recipes existing in the technology landscape and $|\Gamma|$ the number of externality configurations generated by external variables. Then G represents all the possible global configurations of a technology that takes into account both of the number of possible recipes and of the number of configurations of external variables that influence the efficiency of technology. We may easily represent the intranality and externality of a technology by building up a matrix constituted by columns representing all the operations o_i , $i = 1$ to N of a technology and rows representing all the instructions p_{ijk} $i = 1, \dots, N$ and $j = 1, \dots, M_i$ of the technology and all considered external parameters q_{ij} , $i = 1, \dots, B$ and $j = 1, \dots, R_i$ then assuming for each position a value of 1 whether influence of the specific instruction or external variable on the efficiency of the specific operation exists or 0 otherwise:

O_1	O_2	O_N
P_{11}		
P_{12}		
.....			
P_{NMN}		
Q_{11}		
Q_{12}		
.....			
Q_{BRB}		

This matrix corresponds to a simplified adjacent matrix of a tri-parted graph constituted by the subset of instructions, the subset of external parameters and the subset of operations with arcs that are oriented exclusively from instructions and external parameters nodes to operations nodes. This graph represents the global interactions existing for a technology. Graph may appear completely connected or in form of clusters playing an important role in modelling a technology and designing exploration of correspondent technology landscapes. Such graphs may find for example application in experimental planning for reduction of number of necessary experiments.

FIGURES

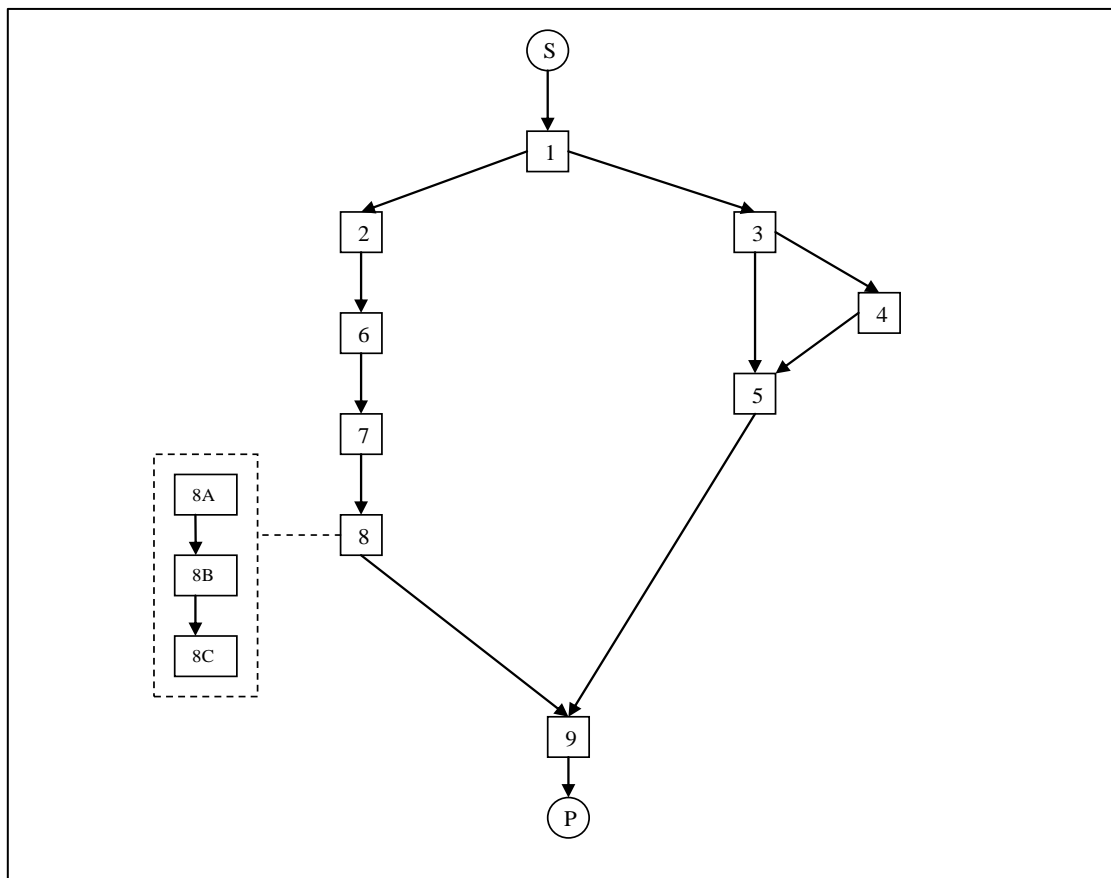

Fig.1. Example of technology structure: production of valves and faucets

Operations

- S. Starting with copper and zinc ore
- 1. Production of molten brass
- 2. Production of brass ingots
- 3. Production of brass bars
- 4. Hot stamping
- 5. Machining
- 6. Casting
- 7. Finishing
- 8. Chromium plating
 - 8A. Degreasing
 - 8B. Nickelizing
 - 8C. Chroming
- 9. Assembling
- P. Valves and faucets products

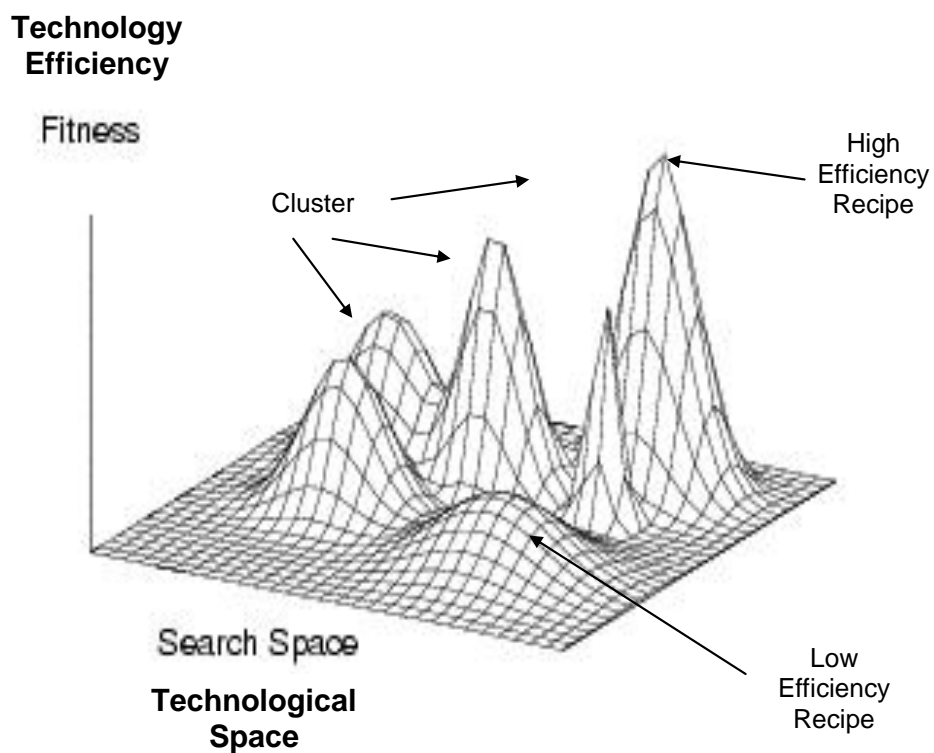
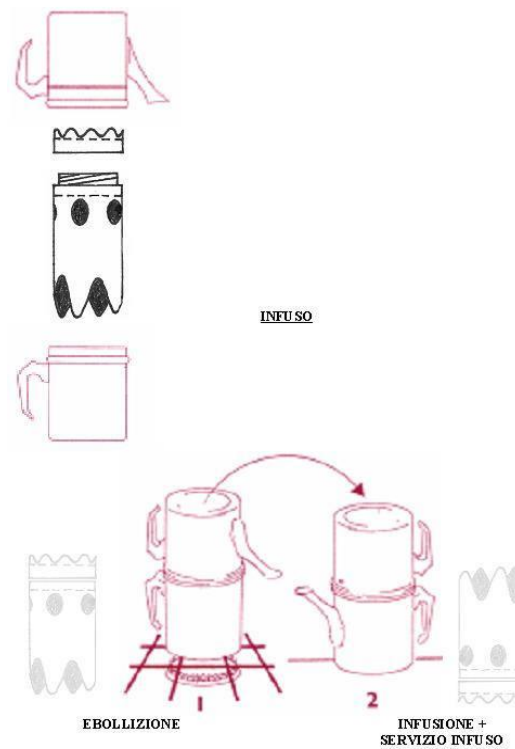

Fig. 2. Typical aspect of a simplified technology landscape



Fig. 3. A view of Apple 1 consisting in a motherboard connected with a keyboard and a domestic TV apparatus



Napoletana

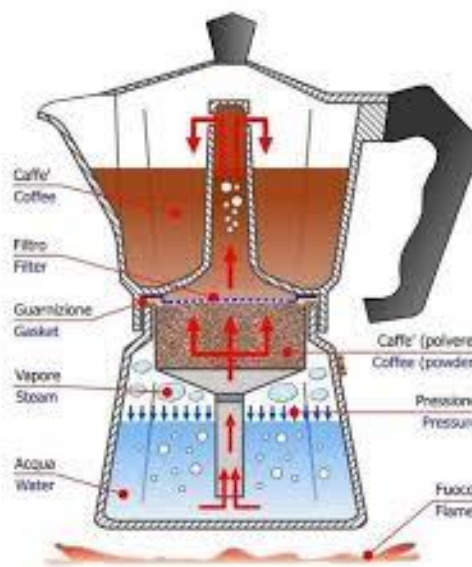

Moka Express

Fig. 4. Example of radical innovation by combinatory developments in coffee-makers