

UDC 621.791.72 : 621.791.052 : 620.17

DOI: 10.15587/1729-4061.2016.85852

Проведено аналіз пошкоджуваності металу зварних з'єднань паропроводів із Cr–Mo–V теплостійких перлітних сталей, які тривалий час експлуатуються в умовах повзучості та малоциклової втоми. Наведені зварні з'єднання пошкоджуються одночасно порами повзучості та тріщинами втоми. Розглянуто фактори, які викликають пошкоджуваність, а також залежність пошкоджуваності від структури зварних з'єднань і умов експлуатації. Їх пошкоджуваність переважно має крихкий характер

Ключові слова: пошкоджуваність зварних з'єднань, зварні з'єднання паропроводів, зона термічного впливу, теплостійкі перлітні сталі

Проведен анализ повреждаемости металла сварных соединений паропроводов из Cr–Mo–V теплоустойчивых перлитных сталей, длительно эксплуатируемых в условиях ползучести и малоциклового усталости. Данные сварные соединения повреждаются одновременно порами ползучести и трещинами усталости. Рассмотрены факторы, вызывающие повреждаемость, а также зависимость повреждаемости от структуры сварных соединений и условий эксплуатации. Их разрушаемость преимущественно имеет хрупкий характер

Ключевые слова: повреждаемость сварных соединений, сварные соединения паропроводов, зона термического влияния, теплоустойкие перлитные стали

RESEARCH INTO DEFECTIVENESS OF WELDED JOINTS OF STEAM PIPES OPERATED OVER A LONG TIME

A. Glushko

Postgraduate student

Department of welding

National Technical University

«Kharkiv Polytechnic Institute»

Bagaliya str., 21, Kharkiv, Ukraine, 61002

E-mail: alenka92@list.ru

1. Introduction

Welded joints of the high pressure steam pipelines are the most damageable elements of the Thermal Power Plants power generating units. The level of defectiveness of the welded joints, which operate over long periods under conditions of creep and low-cycle fatigue, is one of the most significant factors, which determine reliability and service life of the work of TPP power units.

A steam-conducting tract of power unit with its elements represents a single thread of a pipeline. Power unit includes about 15 thousand welded joints. An estimation of the residual resource of the high pressure steam pipeline (one of the most damageable ones) is performed by determining the level of defectiveness of its metal, degradation of structure and mechanical properties.

In the presence of specific structural, chemical and mechanical inhomogeneity, the operating characteristics of metal of the welded joints of steam pipelines are 0.6–0.8 of the analogous characteristics of basic metal. The existence of heterogeneity predetermines an increase in the intensity of defectiveness of welded joints, which significantly depends on the stability of their structure.

The equipment of thermal power plants in the European Union countries, which ran out of its performance resource, is removed from operation. In Ukraine, at a number of thermal power stations, base resource (after its expiry) is further prolonged for unidentified period. This makes it possible to directly study the degradation

of structure and the mechanism of defectiveness of the long operated power machinery equipment, which is expedient for the detection of its residual resource and it is relevant.

2. Literature review and problem statement

In the process of operation, metal of steam pipelines is affected in the largest degree by the following factors:

- temperature of operation, strain from the internal steam pressure, stresses, caused by the arrangement of supporting systems;
- cyclic nature of work (starts-stops).

The high pressure steam pipelines of TPP are manufactured predominantly of the heat-resisting pearlitic steels 15H1M1F and 12H1MF [1]. The initial structure of steam pipelines and their welded joints, as well as the checking of condition of their metal in the process of operation, are regulated by normative documentation [2]. The sections of the heat affected zone (HAZ) of welded joints made of steels 15H1M1F and 12H1MF after high-temperature tempering must have a structure of the tempered bainite, troostite or sorbite [3]. Under conditions of prolonged operation, the initial structure of HAZ sections of welded joints, as well as weld material and base metal, is converted into the ferrite-carbide mixtures that differ in structure, which is caused by the physical chemical processes, which take place in their metal [4].

These processes that have a specific sequence, which characterize the degradation of metal of the welded joints, include:

1. Progress of the carbide reactions $M_3C \rightarrow M_7C_3 \rightarrow M_{23}C_6$ [5].
2. Coagulation of carbide phases of group I. Predominantly, $M_{23}C_6$ by the boundaries of grains of the α -phase [6].
3. Formation of the segregations of chromium, molybdenum, vanadium, silicon and manganese in the boundary zones of grains of the α -phase. Their level of concentration can exceed by 2–4 times the average level of concentration of the indicated elements throughout the body of grains of the α -phase [7].
4. Development of micro pores of creep and micro cracks of fatigue, and their transformation into the macro pores of creep and macro cracks of fatigue [8].
5. Nucleation of micro pores of creep (size 0,03–0,07 μm) and micro cracks of fatigue (size 0,7–1,1 μm) [9].

6. Redistribution of the alloying elements of chromium, molybdenum and vanadium between grains of the α -phase and carbides.

7. Self-diffusion of chromium, molybdenum, vanadium, silicon and manganese from the central zones of grains of the α -phase into their near-boundary zones, as well as the self-diffusion of the indicated elements along the grain boundaries.

8. Simultaneous, mixed displacement of dislocations via creeping and sliding [10, 11].

The formation of defectiveness in metal of the welded joints of steam pipelines for the first time (before their repair) and the formation of defectiveness in the repaired welded joints have their special features. Types of the initial damages of metal of the welded joints, grouped by the generality of attributes [1–5, 7, 10, 12–13], are given in Table 1.

The represented data make it possible to reveal the mechanism of defectiveness, to estimate reliability and to determine residual resource of the welded joints.

Table 1

Types of damages of the welded joints

Type of defectiveness and conditions for its development	Location of damage and crack orientation towards the weld metal	Metallographic attribute of defectiveness	Reasons that cause defectiveness
Cracks of creep, which are formed by the action of operating stresses and temperatures, which exceed the designed ones (overheats). Presence of structural inhomogeneity at the sections of incomplete recrystallization, fusion and overheating of HAZ of the welded joints	Sections of incomplete recrystallization, fusion and HAZ overheating. Weld metal. The nucleation of cracks occurs from external surface of the welded joints into their depth. Transverse cracks in the welded joints of tees with the thinned pipe connection	Intergranular nature of the nucleation and development of cracks. Presence of the new decay products of austenite in the form globularized pearlite at the section of incomplete recrystallization of HAZ. Presence of coarse grains of structurally-free ferrite at the section of HAZ fusion	Operational, caused by: degradation of the structure of welded joints; overheats (emergency discharge of vapor); stresses, which exceed those permitted because of the unsatisfactory arrangement of supporting-suspension system and speeds of warming-up at the starting regimes, which exceed those permitted. Technological, caused by the increased structural inhomogeneity, which is formed at the increased welding heating of the fabricated connections, as well as by the discrepancy between chemical composition of weld metal and the normative requirements. Structural, that allow the high intensity of local stresses, which is caused by the unsatisfactory form of the welded joints
Cracks of thermal fatigue, caused by the existence of high cyclic thermal stresses	Sections of fusion, overheating and incomplete HAZ recrystallization, the weld metal, places of change in thicknesses of steam pipelines. Nucleation and development of cracks occurs from internal surface of steam pipelines. In the nozzle connections, the cracks are oriented radially. Presence of the networks of cracks at the internal surface	Transgranular nature of the cracks	Operational, whose formation is caused by cyclic variations in the temperature of metal and by action of working medium. Structural, predetermined by high stress concentration in the places of welding defects: nonfusions, undercuts, inclusions, crystallization cracks in the weld root, the presence of structural and chemical inhomogeneity, as well as those that form in the places of contact between pipe elements of different thickness
Corrosion-fatigue cracks	Sections of fusion, overheating and incomplete recrystallization of HAZ, the weld metal of the connections to be welded. Defectiveness is formed at the internal surface of the welded joints of steam pipelines. Cracks have a threadlike form or a form with an obtuse angle of crack opening. The vertex of the angle is filled with the products of corrosion. The defectiveness of metal may take the form of the networks of cracks	Cracks have intragranular and mixed direction. The branching of cracks is insignificant. The nature of cracks is predominantly transgranular	Operational, that are formed under the action of corrosive medium, activated by thermal stresses and those of cyclic nature. Structural, predetermined by the local stress concentration in the places of contact between the pipe elements of steam pipelines with different thickness, welding defects, nonmetallic inclusions, notches and the presence of structural inhomogeneity

The given types of damages in the welded joints are expedient to use for refining the special features of physical-chemical processes and structural changes, which pre-determine them. The damages examined are characteristic for the welded joints, which exhausted their base resource, including the prolonged one, which is characteristic for the majority of thermal power plants in Ukraine. With an increase in the operating time of welded joints (>270000 h), the defectiveness of their metal undergoes changes, which necessitates investigation of the physical-chemical processes, which provide for the mechanism of their defectiveness. The study of defectiveness and degradation of metal of the welded joints is the subject of a number of papers [5, 7–11, 13–14, 16]; however, up to now, the connection has not been established between diffusion processes and the processes of displacement of dislocations and their joint manifestation on the formation of creep pores and fatigue cracks.

3. The aim and tasks of the study

The aim of present work is the identification of peculiarities of defectiveness of metal of the welded joints, which are operated over long periods under conditions of creep and low-cycle fatigue, by creep pores and fatigue cracks.

To achieve the set aim, it was necessary to solve the following tasks:

- to perform the classification of defectiveness by the types of damages;
- to refine the mechanism of defectiveness by creep pores;
- to refine the character of defectiveness by fatigue cracks.

4. Peculiarities of defectiveness of metal of the welded joints of steam pipelines by the mechanism of creep

Under conditions of prolonged operation of the welded joints of steam pipelines, at constant parameters, temperature $T_E=545\text{ }^\circ\text{C}$ and steam pressure 25 MPa, the diffusion mechanism of creep in their metal is manifested. Let us examine the scheme of self-diffusion in a crystal of the α -phase for refining the mechanism of creep. Let us assume that the crystal under creep conditions undergoes uniaxial expansion, Fig. 1, and the sections of its border AB and CD are located perpendicularly to the applied stress σ that causes the formation of micro pores.

Energy of the formation of a micro pore will equal $\sigma\Omega$. At constant stress and temperature, the thermally equilibrium concentration of the formation of micro pores was determined by the refined formula [12]:

$$C_v = C_{v0} \exp\left(-\frac{\Delta H_f - \sigma\Omega}{k_B T}\right), \quad (1)$$

where C_{v0} is the constant, connected to a change in the entropy at the formation of micro pore (dimensionless magnitude); ΔH_f is the enthalpy of the process of forming the micro pore; k_B is the Boltzmann constant; T is the absolute temperature.

Under creep conditions, under the action of constant stress, there occurs, accordingly, a flow of micro pores, which has specific orientation. Simultaneously there occurs the flow, opposite to it, of the elements of

substitution (Cr, Mo, V, Si, Mn), as well as the introduction (C, H_2), which also contributes to the polygonization of crystal and its deformation. The flow of micro pores, formed under creep conditions, can be expressed by formula, obtained from the Arrhenius equation:

$$J = D_{v1} D_{v2} C_{v1} \frac{\sigma\Omega}{k_B T} \frac{1}{d}, \quad (2)$$

where d is the averaged diameter of crystal of the α -phase; C_{v1}/d is the concentration gradient of pores along the crystal boundaries; D_{v1} is the coefficient of grain-boundary diffusion; D_{v2} is the coefficient of volumetric diffusion; J is the number of micro pores, which intersect in time t the crystal boundary d .

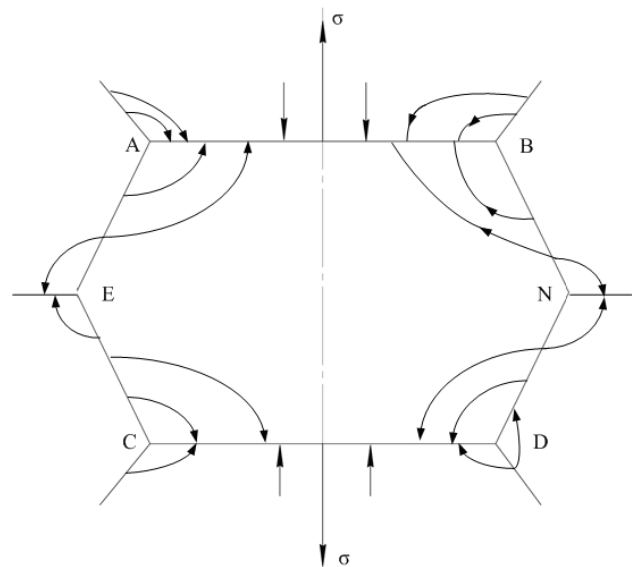

Fig. 1. Scheme of the diffusion displacement (pointer) of elements of chromium and molybdenum in the crystal of the α -phase being deformed

D_{v1} and D_{v2} have dimensionality $1/[\text{Length}] \cdot [\text{Time}]$. The total volume of the micro pores, which intersect crystal boundary and sub-boundary (inside the crystal) in time t will comprise $J_{1,2}\Omega n$, respectively. The coefficients of self-diffusion of boundary Ω_{11} and volumetric Ω_{12} compose $D_{v1} \cdot C_{v1} \cdot \Omega_{11}$ and $D_{v2} \cdot C_{v1} \cdot \Omega_{12}$, respectively.

Let us write down the rate of the stretching of crystal boundaries in the form: $D_1\sigma\Omega/k_B \cdot T_d$. We considered that the energy of activation of the process of boundary diffusion is approximately 0,4...0,6 from the energy of volumetric activation [14].

In the process of deformation of the crystal of the α -phase, the dislocation density grows and the polygonal (fragmented) structure of crystals is formed accordingly. The increased dislocation density impedes the displacement of the subsequent dislocations. Simultaneously, the presence of the diffusion displacement of elements ensures the process of creeping of dislocations that leads to their regrouping and partial annihilation, as well as subsequent reduction in the internal stresses. A competing effect-compensation of deformation hardening is manifested, which makes it possible to form the boundaries of subgrains, that is, the fragmentation (polygonization of grains of the α -phase) occurs. A motion of dislocation is controlled by the diffusion displacement

of the elements of chromium and molybdenum, to a lesser degree, of vanadium, silicon and manganese.

Let us note that the level of deformation of the sections of heat-affected zone considerably exceeds the mass deformation of steam pipelines, which is (at the operating time of welded joints exceeding 250000 h) about 0,5...0,7 % [13].

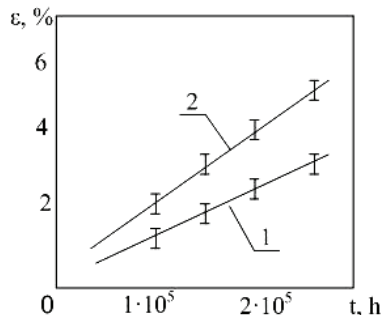

Fig. 2. Dependence of relative deformation of metal of the welded joints made of steel 15H1M1F on the prolonged operating time: 1 – metal of the section of HAZ overheating; 2 – metal of the section of incomplete recrystallization

Let us note that the deformation of welded joints made of steel 15H1M1F is somewhat reduced than the deformation of the welded joints made of steel 12H1MF that work under close conditions [14]. In the process of deformation of HAZ sections, their structure undergoes certain changes, characteristic for the initial stage of recrystallization [6]. The micro pores are formed and developed simultaneously [12].

In the metal of welded joints, operated for a long period under creep conditions, the effect of dispersed strengthening of the α -phase by carbides of group I and II manifests itself vividly. This strengthening, according to different estimates [4, 6–7, 10], is from 80...90 % of their general strengthening, caused by the action of other known factors. The presence of carbide precipitates, especially finely dispersed VC and Mo₂C, substantially reduces intensity of the displacement of dislocations by sliding, which contributes to an increase in the deformation stresses. The mean speed of dislocations becomes inversely proportional to their concentration ρ , which leads to the reduction in stresses. The process of self-diffusion of alloying elements of chromium, molybdenum, vanadium in the grains of the α -phase, as well as along their boundaries, is characterized by different intensity of their displacement [13]. Specifically finely dispersed precipitates of VC and Mo₂C render the steels 15H1M1F and 12H1MF dispersed strengthening, and they also alloy the α -phase.

Let us examine the action of the Orowan mechanism [15] in connection to the metal of welded joints of steam pipelines, operated under conditions of creep (exceeding 270000 h). Assume that a linear dislocation is exposed to force $F=\tau b$, directed normally, where τ is the stress, constant along the entire dislocation line, perpendicular to this line and coinciding with the direction of the shift. Let us represent a sliding plane, where second phases (carbide precipitates) are located, which are an obstacle for the motion of dislocations, Fig. 3.

Let us represent sequential stages of displacement of the dislocations. In contrast to the Orowan model, where the particles of the second phases are spherical, in the proposed

model such particles have the elongated form, which is characteristic for the carbides of group 1 that coagulate lengthwise [16]. In the process of motion, the dislocations bend between the particles of the second phases and the formed adjacent loops, a contact in front of the particles is established, which leads to their annihilation. The dislocations are torn apart from the locked segments; they acquire rectified shape and move in direction A, while the closed loops remain on the B₁B₂ precipitates. The displacement of dislocations is controlled by the action of tangential stress. Here $\tau = \alpha Gb/\Lambda$, where α is the magnitude of the order of unity; G is the modulus of shift; b is the Burgers vector; Λ is the mean distance between the precipitates of the second phases.

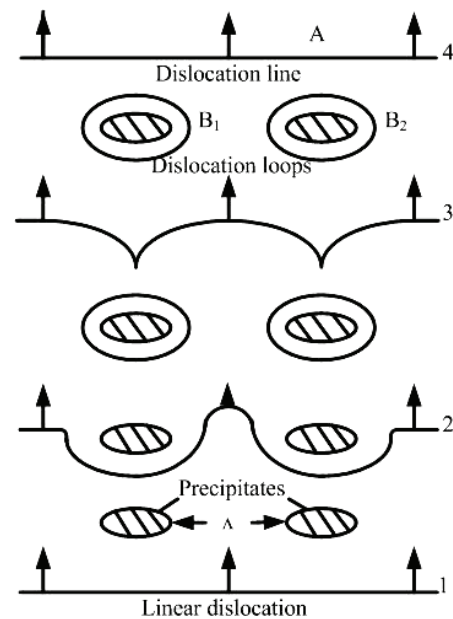

Fig. 3. Sequence of stages of the passage of dislocation through carbide precipitates

The stress, necessary for the displacement of dislocations, comprises:

$$\tau = \tau_f + k_m \frac{\alpha Gb}{\Lambda}, \tag{3}$$

where τ_f is the resistance to the motion of dislocations in the section between the precipitates; k_m is the coefficient, depending on the shape of precipitates; α is the magnitude of the order of unity.

Total stress depends both on the shape of precipitates and on the distance between the precipitates.

It was established that the stretched (elongated) shape of precipitates in the larger degree impedes the displacement of dislocations than the spherical, which is confirmed by their increased density near the precipitates. The elongated form of precipitates (M₂₃C₆, M₇C₃) is formed as a result of their coagulation along the boundaries of grains of the α -phase [5]. The shape of carbide precipitates may have the elements of continuity (Fig. 4). The creep pores are formed predominantly on the border of contact of the coagulating precipitates and grains of the α -phase. Their formation significantly depends on the shape of precipitates. They established that the intensity of formation of pores noticeably increases when the elongated shape of precipitates is present.

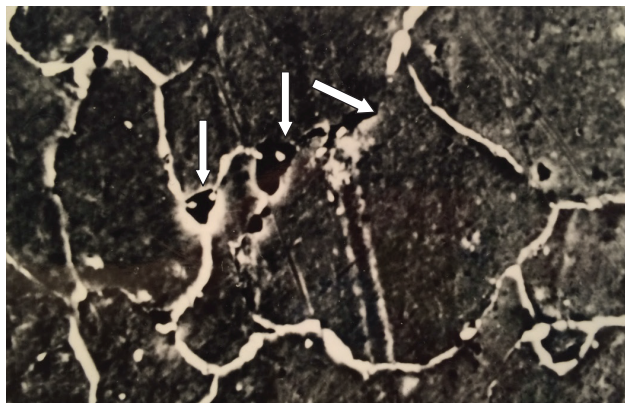

Fig. 4. Distribution of carbides $M_{23}C_6$ along the boundaries of grains of the α -phase of metal at the section of incomplete recrystallization of the welded joint made of steel 15H1M1F. $\times 4500$. Resource is 290000 h. Pores are indicated by pointers

In the process of sequential displacement of dislocations through the carbide precipitates, dislocation loops will be accumulated around each precipitate (operating time of the welded joints is 200000–250000 h), which provides for the formation of the stress, opposite to their motion. The action of two competing factors is manifested: an increase in the plastic deformation and the growth of inverse stress. Deformation hardening is reduced by the effect of self-diffusion (boundary and volumetric) of chromium and molybdenum, which is ensured by the presence of gradients of chemical potentials [13].

It was established that with an increase in stable finely dispersed carbides of group 1 (VC, Mo_2C), as well as with their uniform distribution in the metal of welded joints, strength limit grows at statistical tension. They revealed that the strength limit when carbides of group II are present ($M_7C_3, M_{23}C_6$), which have the elongated shape (Fig. 4), will be approximately by 15–25 % lower than the strength limit when finely dispersed carbides of spherical shape are present. The influence of the shape of carbides is manifested to a larger degree at the impact tests. For example, KCV in the presence of carbides in spherical form reached $40 J/cm^2$ (welded joint made of steel 15H1M1F), and in the presence of carbides in the elongated shape – 10–15 (Fig. 4). Therefore, the steels, operated for a long time under creep conditions, are expedient to contain stable finely dispersed carbides of spherical shape.

It was established that the creep cracks (Table 1) are formed at the sections of incomplete recrystallization of HAZ (about 75 %) and fusion (approximately 15 %), Fig. 5. The remaining is crack formation at other sections of HAZ, as well as in the region of weld metal and in the region of base metal. The cracks of creep are formed at the surface zone of metal of the welded joints, and then they propagate predominantly along the grain boundaries into the depth of their metal (Fig. 5, a, b).

A development of the creep cracks occurs predominantly by the brittle mechanism, Fig. 6. This development is promoted by the carbides of group I that coagulate lengthwise [5], as well as the segregation phenomena of elements of chromium, molybdenum, silicon, manganese in the near-boundary zones of grains of the α -phase [6]. The presence of segregations and carbide precipitates in the near-boundary zones of grains noticeably (approximately by 15–25 %) decreases impact toughness of metal of the

welded joints and their role in the formation of defectiveness by the brittle mechanism is significant. Segregations in the near-boundary zones of grains of the α -phase contribute to the accelerated passage of solid-phase carbide reactions $M_3C \rightarrow M_7C_3 \rightarrow M_{23}C_6$, as well as to the lengthwise coagulation of carbides $M_{23}C_6$ [5].

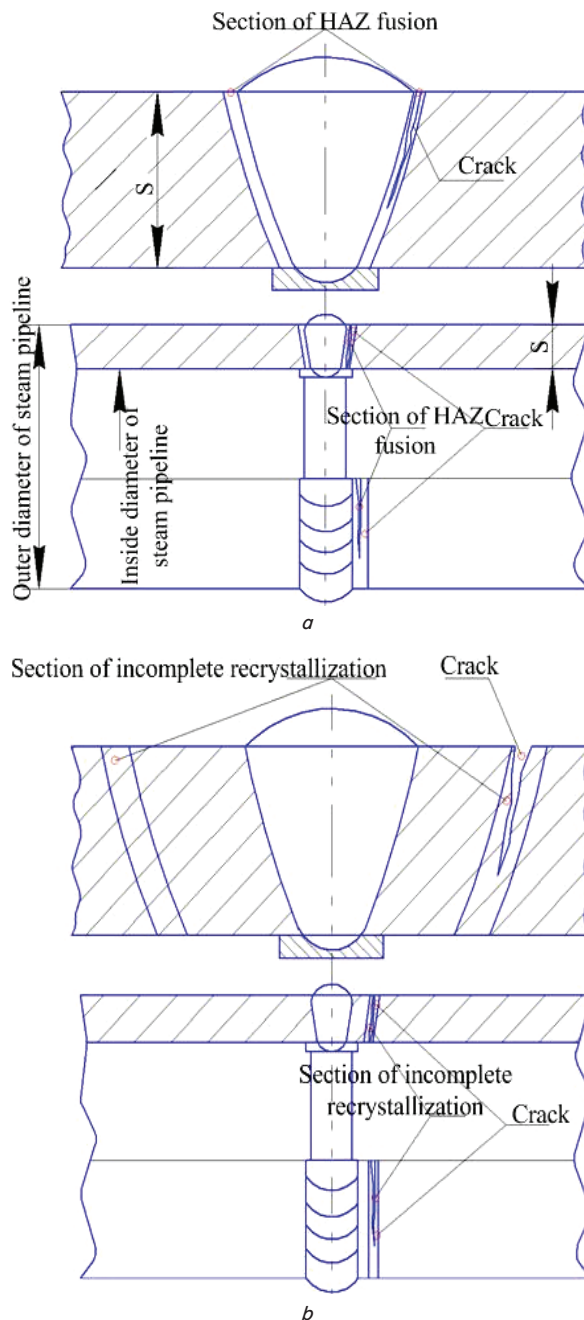

Fig. 5. Scheme of typical damages of the welded joints of steam pipelines by the creep cracks: cracks that are formed at the section of incomplete recrystallization: Crack – crack; Section of incomplete recrystallization – section of incomplete recrystallization; S – thickness of the wall of steam pipeline; Section of HAZ fusion – section of HAZ fusion; Outer diameter of steam pipeline – outer diameter of steam pipeline; Inside diameter of steam pipeline – inside diameter of steam pipeline

Structural and chemical changes lead to the reduction in resistance of metal of the welded joints to the pore formation and development of the creep cracks by the brittle

mechanism. They established that, with the damage by pores in the volume of 0,2 of metal of the sections of incomplete recrystallization, fusion and HAZ overheating, its further defectiveness is accelerated. The subsequent defectiveness occurs mostly by the brittle mechanism. Therefore, such welded joints should be cast out. Pore formation in the examined sections of HAZ is interconnected with the creep in their metal, which is nonlinear in nature. It is possible to note a tendency of an increase in the intensity of pore formation at overheating (emergency discharge of vapor), as well as during cyclic operation of steam pipelines (starts-stops).

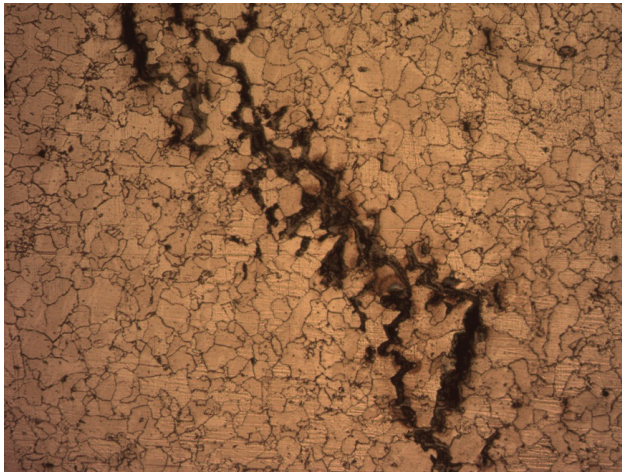

Fig. 6. Intergranular nature of the creep crack, which is developed predominantly by the brittle mechanism in the HAZ of welded joint made of steel 12H1M1F. Resource 290000 h. $\times 500$

5. Refinement of the factors that cause defectiveness in metal of the welded joints by the mechanism of fatigue

The regime of operation of power units with increased in frequency starts-stops (cyclic regime) leads to an increase in the intensity of defectiveness in metal of the welded joints by fatigue cracks (Fig. 7).

The fatigue cracks, caused by action of cyclic stresses, are formed predominantly at the internal surface zone of the welded joints. Their nucleation occurs at the sections of fusion, overheating and incomplete recrystallization of HAZ, as well as in the region of weld metal, near backing rings, in the places of contact between pipe elements of different thickness, in the region of the fillet welds of nozzle and tee welded joints. Fatigue cracks are most frequently formed in the metal of welded joints of steam pipelines of hot industrial superheating, in the sites of installation of bolts, valves, drainages, which ensure fulfillment of operations on control of heating and cooling.

With the operating time of power units exceeding 250000 h, under conditions of creep and low-cycle fatigue, there is noted a steady tendency toward an increase in the intensity of defectiveness of metal of the welded joints. The following factors influence an increase in the intensity of defectiveness in metal of the welded joints: degradation of structure and properties, the appeared pinched places of steam pipelines, deflection of the laying out of steam pipelines from the design. This increase is also contributed by: redistribution of weight and compensating loads, unsatisfac-

tory condition of the supporting – uspension system of steam pipelines.

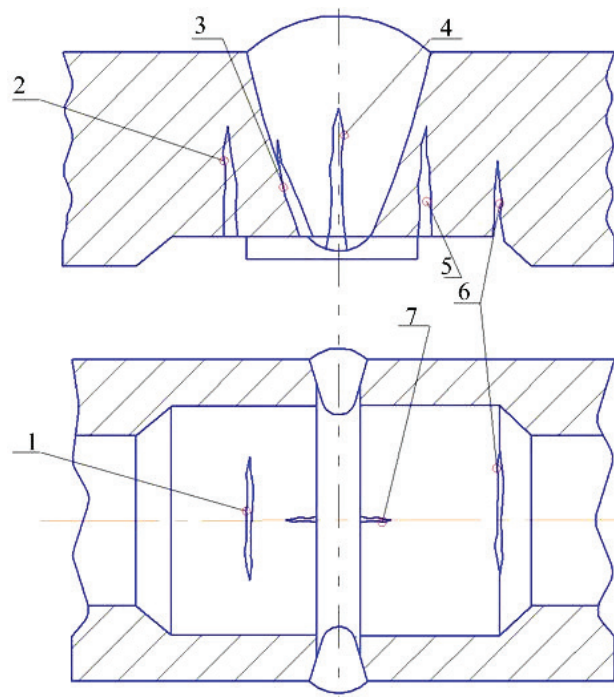

Fig. 7. Fatigue cracks, which are formed in the butt-welded joints of steam pipelines: 1 – at the section of incomplete recrystallization of HAZ; 2 – at the section of overheating; 3 – at the section of fusion; 4 – in the weld metal (transverse cracks); 5 – near the backing ring; 6 – in the place of contact between steam pipelines of different thicknesses; 7 – in the weld metal (longitudinal cracks)

The forced maneuverable mode in the operation of power units contributes to acceleration in the degradation of metal of the welded joints of steam pipelines and it leads to a 25...30 % decrease in their long-term strength [7–10]. Simultaneously, prolonged plasticity ψ of the welded joints is reduced. For example, ψ of the welded joints of hot industrial superheating (maneuverable operating mode) comprised 7–9 %, and of the analogous welded joints that work under regime close to the stationary, is 20–30 %.

It is expedient to refine special features of defectiveness of the welded joints of steam pipelines, working in the maneuverable operating mode, from their structural condition, which will make it possible to decrease the intensity of defectiveness of the welded joints and to improve resource of their operation.

6. Discussion of results of examining the influence of creep pores and fatigue cracks on the metal of welded joints of steam pipelines

They established that the displacement of dislocations by sliding and creeping occurs at the simultaneous coagulation of carbides from group I. The accumulation of dislocations near the carbides that are of elongated shape is characterized by their partial annihilation.

The development of defectiveness by the brittle mechanism is also contributed by the segregation phenomena in the near-boundary zones of grains of the α -phase, which are the increased concentrations of the substitution elements.

In order to decrease defectiveness of the welded joints that are operated for a long period, it is expedient to reduce the intensity of diffusion displacement of the substitution elements into the near-boundary zones of grains of the α -phase. This decrease is possible under conditions of the increase in enthalpy of the bond between the substitution elements and elements of the matrix lattice of the α -phase. The attainment of stability of elements in a crystal should be calculated using the corresponding gradients of their chemical potentials. Exploring the defectiveness of welded joints of steam pipelines over prolonged operation is useful for the evaluation of their reliability, as well as for determining their residual resource.

It is expedient to use the given results of present study for further investigation of the physical-chemical processes that occur in metal of the steam pipelines under conditions of long operation.

7. Conclusions

1. We revealed special features of simultaneous defectiveness by the creep pores and by the fatigue cracks of metal of the welded joints of steam pipelines, operated over long period (250000 ch) under conditions of creep and low-cycle fatigue.

2. We determined that the formation of defectiveness of the welded joints of steam pipelines by the mechanisms of creep and fatigue is contributed by the carbide precipitates from group I that coagulate lengthwise, as well as the segregation phenomena in the near-boundary zones of grains of the α -phase.

3. We established that the structural and chemical changes in metal of the welded joints operated over long period account for the development of their defectiveness predominantly by the brittle mechanism.

References

1. RD 10–577–03. Tipovaya instrukciya po kontrolyu metalla i prodleniyu sroka sluzhby osnovnyh ehlementov kotlov, turbin i truboprovodov teplovyh ehlektrostantsij [Text]. – Moscow: NTC «Promyshlennaya bezopasnost'», 2004. – 127 p.
2. SO 153–34.17.470–2003. Instrukciya o poryadke obsledovaniya i prodlenii sroka sluzhby paroprovodov sverh parkovogo resursa. Gosgortekhnadzor Rossii, Minehnergo Rossii, RAO «EEHS Rossii» [Text]. – Moscow: OAO VTI, 2004.
3. RD 10–249–98. Normy rascheta na prochnost' stacionarnykh kotlov i truboprovodov para i goryachej vody [Text]. – Moscow: FGUP NTI «Prombezopasnost'», 2002.
4. Berezina, T. G. Termicheskaya obrabotka stykov paroprovodov iz stali 15H1M1F [Text] / T. G. Berezina, M. A. Shnajder // Ehlektricheskie stancii. – 1969. – Vol. 6. – P. 25–28.
5. Dmitrik, V. V. Osobennosti degradacii metalla svarnykh soedinenij paroprovodov TEHS [Text] / V. V. Dmitrik, S. N. Bartash // Avtomaticheskaya svarka. – 2014. – Vol. 32-33. – P. 21–28.
6. Dmitrik, V. V. Strukturnye izmeneniya matalla svarnykh soedinenij paroprovodov v processe ehkspluatacii [Text] / V. V. Dmitrik, O. V. Sobol', M. A. Pogrebnoj, A. V. Glushko, G. I. Ishchenko // Avtomaticheskaya svarka. – 2015. – Vol. 12. – P. 26–30.
7. Hromchenko, F. A. Resurs svarnykh soedinenij paroprovodov [Text] / F. A. Hromchenko. – Moscow: Mashinostroenie, 2002. – 348 p.
8. Hald, J. Microstructure and long-term properties of 9–12 % Cr steels [Text] / J. Hald // International Journal of Pressure Vessels and Piping. – 2008. – Vol. 85, Issue 1-2. – P. 30–37. doi: 10.1016/j.ijpvp.2007.06.010
9. Abe, F. Coarsening behavior of lath and its affect on creep rates in tempered martensitic 9 % Cr–W steels [Text] / F. Abe // Material Science and Engineering: A. – 2004. – Vol. 387-389. – P. 565–569. doi: 10.1016/j.msea.2004.01.057
10. Kumanin, V. I. Dolgovechnost' metalla v usloviyah polzuchesti [Text] / V. I. Kumanin, L. A. Kovaleva, S. V. Alekseev. – Moscow: Metallurgiya, 1998. – 224 p.
11. Sawada, K. Effect of W on recovery of lath structure during creep of high chromium martensitic steels [Text] / K. Sawada, M. Takeda, K. Maruyama, R. Ishii, M. Yamada, Y. Nagae, R. Komine // Materials Science and Engineering: A. – 1999. – Vol. 267, Issue 1. – P. 19–25. doi: 10.1016/s0921-5093(99)00066-0
12. Sudzuki, T. Dinamika dislokacij i plastichnost' [Text] / T. Sudzuki, H. Esinaga, S. Takeuti. – Moscow: Mir, 1989. – 294 p.
13. Dmitrik, V. V. Osobennosti poroobrazovaniya v svarnykh soedineniyah paroprovodov v usloviyah dlitel'noj ehkspluatacii [Text] / V. V. Dmitrik, A. V. Glushko, S. G. Grigorenko // Avtomaticheskaya svarka. – 2016. – Vol. 9. – P. 56–60.
14. Dmitrik, V. V. K mekhanizmu diffuzii hroma i molibdena v metalle svarnykh soedinenij paroprovodov [Text] / V. V. Dmitrik, T. A. Syrenko // Avtomaticheskaya svarka. – 2016. – Vol. 10. – P. 22–26.
15. Ekobori, T. Fizika i mekhanika razrusheniya i prochnosti tverdykh tel [Text] / T. Ekobori. – Moscow: Metallurgiya, 1981. – 268 p.
16. Dmitrik, V. V. K povrezhdaemosti svarnykh soedinenij paroprovodov po mekhanizmu polzuchesti [Text] / V. V. Dmitrik, S. N. Bartash // Metallofizika i novejshe tekhologii. – 2010. – Vol. 32, Issue 12. – P. 1657–1663.