



**GOLD (I)-CATALYZED RETRO-CYCLOPROPANATION REACTION AND
DEVELOPMENT OF TRINDANE-BASED APPROACH TOWARD C60**
César Rogelio Solorio Alvarado

Dipòsit Legal: T. 1714-2011

ADVERTIMENT. La consulta d'aquesta tesi queda condicionada a l'acceptació de les següents condicions d'ús: La difusió d'aquesta tesi per mitjà del servei TDX (www.tesisenxarxa.net) ha estat autoritzada pels titulars dels drets de propietat intel·lectual únicament per a usos privats emmarcats en activitats d'investigació i docència. No s'autoritza la seva reproducció amb finalitats de lucre ni la seva difusió i posada a disposició des d'un lloc aliè al servei TDX. No s'autoritza la presentació del seu contingut en una finestra o marc aliè a TDX (framing). Aquesta reserva de drets afecta tant al resum de presentació de la tesi com als seus continguts. En la utilització o cita de parts de la tesi és obligat indicar el nom de la persona autora.

ADVERTENCIA. La consulta de esta tesis queda condicionada a la aceptación de las siguientes condiciones de uso: La difusión de esta tesis por medio del servicio TDR (www.tesisenred.net) ha sido autorizada por los titulares de los derechos de propiedad intelectual únicamente para usos privados enmarcados en actividades de investigación y docencia. No se autoriza su reproducción con finalidades de lucro ni su difusión y puesta a disposición desde un sitio ajeno al servicio TDR. No se autoriza la presentación de su contenido en una ventana o marco ajeno a TDR (framing). Esta reserva de derechos afecta tanto al resumen de presentación de la tesis como a sus contenidos. En la utilización o cita de partes de la tesis es obligado indicar el nombre de la persona autora.

WARNING. On having consulted this thesis you're accepting the following use conditions: Spreading this thesis by the TDX (www.tesisenxarxa.net) service has been authorized by the titular of the intellectual property rights only for private uses placed in investigation and teaching activities. Reproduction with lucrative aims is not authorized neither its spreading and availability from a site foreign to the TDX service. Introducing its content in a window or frame foreign to the TDX service is not authorized (framing). This rights affect to the presentation summary of the thesis as well as to its contents. In the using or citation of parts of the thesis it's obliged to indicate the name of the author.

DOCTORAL THESIS

**Gold(I)-Catalyzed Retro-Cyclopropanation
Reaction and
Development of Trindane-Based Approach
Toward C₆₀**

César Rogelio Solorio Alvarado

Supervised by Professor Antonio M. Echavarren
Institut Català d'Investigació Química (ICIQ)



UNIVERSITAT ROVIRA I VIRGILI

T a r r a g o n a

2011

UNIVERSITAT ROVIRA I VIRGILI
GOLD (I)-CATALYZED RETRO-CYCLOPROPANATION REACTION AND DEVELOPMENT OF TRINDANE-BASED
APPROACH TOWARD C60
Cesar Rogelio Solorio Alvarado
DL: T. 1714-2011



Av. Països Catalans, 16
43007 Tarragona
Tel. 977 920 218
Fax. 977 920 225

Tarragona, 27 de octubre de 2011

Hago constar que este trabajo de investigación titulado "*Gold(I)-Catalyzed Retro-Cyclopropanation Reaction and Development of Trindane-Based Approach Toward C₆₀*", que presenta el M. C. César Rogelio Solorio Alvarado para la obtención del título de Doctor, ha sido realizado bajo mi dirección en el Institut Català d'Investigació Química vinculado a la Universitat Rovira i Virgili y que cumple los requisitos necesarios para poder optar a Mención Europea.

Director de Tesis Doctoral

Prof. Antonio M. Echavarren

UNIVERSITAT ROVIRA I VIRGILI
GOLD (I)-CATALYZED RETRO-CYCLOPROPANATION REACTION AND DEVELOPMENT OF TRINDANE-BASED
APPROACH TOWARD C60
Cesar Rogelio Solorio Alvarado
DL: T. 1714-2011

*La ciencia es el alma de la prosperidad
de las naciones y la fuente de vida
de todo progreso.*

*Sorprendernos por algo
es el primer paso de la mente
hacia el descubrimiento.*

Louis Pasteur

UNIVERSITAT ROVIRA I VIRGILI
GOLD (I)-CATALYZED RETRO-CYCLOPROPANATION REACTION AND DEVELOPMENT OF TRINDANE-BASED
APPROACH TOWARD C60
Cesar Rogelio Solorio Alvarado
DL: T. 1714-2011

AGRADECIMIENTOS

El trabajo contenido en la presente disertación, se realizó en el Institut Català d'Investigació Química bajo la dirección del *Profesor Antonio M. Echavarren*, a quien de la manera mas sincera expreso mi admiración, respeto y sobre todo, mi agradecimiento por brindarme su confianza y con ello la oportunidad de “oro” que tanto busqué para realizar mi doctorado.

La investigación realizada a lo largo de esta tesis, fue posible gracias a una beca predoctoral del Institut Català d'Investigació Química desde noviembre de 2007 hasta Octubre de 2008, además de una beca de Formación de Personal Investigador por parte del Ministerio de Ciencia e Innovación desde Noviembre de 2008 hasta la redacción de la presente tesis doctoral. Finalmente en este contexto, quiero agradecer al grupo FARMIVA, S.A. de C. V. (Zapopan, Jalisco, México) por el incondicional apoyo económico que me brindaron durante el periodo de 2007-2009 para iniciar mi estancia y hacer mi situación inmensamente mas llevadera. Durante el periodo de investigación doctoral tuve la oportunidad de hacer un par de estancias de investigación cortas, la primera de ellas en el grupo del Profesor Phil S. Baran en The Scripps Research Institute donde trabajé durante el periodo de junio-agosto de 2010 en colaboración con el grupo de la Profesora Donna G. Blackmond en el mismo instituto. Tanto a Phil como a Donna agradezco la buena disposición y el apoyo que en todo momento me hicieron sentir. La segunda estancia fue realizada en el grupo del Profesor Darren J. Dixon en la Universidad de Oxford, donde estuve colaborando durante el periodo de junio-agosto de 2011, y a quien agradezco por permitirme tener las primeras experiencias en organocatálisis de mi carrera.

Quiero agradecer de forma especial a Sònia Gavaldá, coordinadora administrativa de nuestro grupo de investigación, quien día a día durante estos 4 años de mi estancia desempeñó su trabajo más allá de su deber profesional, ayudándome a empezar y terminar mi doctorado. Muchas gracias Sònia. Agradezco también el trabajo profesional de la técnico de nuestro laboratorio Vanessa Martínez.

Expreso mi agradecimiento también al personal responsable de las áreas de RMN, Espectroscopía de masas y Rayos X, su ayuda fue invaluable en el desarrollo de este trabajo. De igual manera a los compañeros del grupo de informática, Ángel, David, Álvaro y Mario, por su excelente y atenta disposición en los infinitos problemas en la red y con los equipos.

De manera especial agradezco a mi compañero y amigo José María Blasco Mata (chaparrito), por auxiliarme con los horrores en mi redacción al inglés de esta tesis. En el mismo contexto, agradezco a Madeleine, Paul y Tim por colaborar a la causa.

Quiero finalizar agradeciendo a mis compañeros de grupo, e inicio con Yahui from whom every day since I know him, I have learned a strong lesson of discipline and humility; a Claudia de León (Claus o Claudia del Sol) siempre estuviste para escucharme y darme una palabra de aliento cuando me sentía estresado en el lab; gracias a Vero y a Patri por su incondicional apoyo y ayuda en el lab desde que llegué y a María Moreno por el compañerismo, a Riccardo, Paul, Madeleine, Ismael, Carla, Ana(s), Katya, Pili, Anthony, Morgane y Nuria por compartir mis momentos de éxito y desilusión en la química.

Dedicatorias

*Esta tesis doctoral, enmarca no solo un objetivo profesional en mi carrera, sino que cierra un ciclo muy importante de mi vida; en este trabajo está puesto lo mejor de mí en todos los sentidos, y desde luego lo agradezco y dedico **A MIS PADRES** Ángela y Rogelio, porque siempre he encontrado en ellos y en sus ejemplos de vida, los consejos, la luz, el camino, la fortaleza pero sobre todo el apoyo para seguir y culminar mis metas. Lo poco o mucho que soy se lo debo a ellos.*

Dedico este trabajo a mi esposa Irene, por ser mi incondicional compañera de vida, mi fortaleza, mi guía y mi apoyo, porque sus palabras siempre han llenado en mí, el vacío que la química o las circunstancias que lejos de mi patria, la vida me ha hecho enfrentar; nunca habría podido continuar de la misma manera, muchísimas gracias Irene sin ti m.f.y.)(A mi pequeño pensador César Eratziti quien a sus pocos días de vida, me alegra y llena totalmente mi espacio de él.

A mis hermanos Ixchel, Kenia y Angel Isaac, por apoyarme tanto como saben y pueden, por ser mis amigos incondicionales y por todo el cariño y respeto que en sus palabras y actos me demuestran.

Finalmente, mi último año en Tarragona, nunca habría sido tan diferente, mejor y agradable sin mis amigos Robert, Lily, Meli, Marlon y Lucho.

..... a ustedes dedico esta tesis y desde luego

mil gracias por su apoyo.....

UNIVERSITAT ROVIRA I VIRGILI
GOLD (I)-CATALYZED RETRO-CYCLOPROPANATION REACTION AND DEVELOPMENT OF TRINDANE-BASED
APPROACH TOWARD C60
Cesar Rogelio Solorio Alvarado
DL: T. 1714-2011



Funding: MEC, AGAUR, EU, ICIQ



Agència
de Gestió d'Ajuts
Universitaris
i de Recerca



Farmiva



intecat

Conselleria Ingeles 2010
CSD2006-0003

Elaborado por el
Centro de Investigación de
una Aproximación Integrada

UNIVERSITAT ROVIRA I VIRGILI
GOLD (I)-CATALYZED RETRO-CYCLOPROPANATION REACTION AND DEVELOPMENT OF TRINDANE-BASED
APPROACH TOWARD C60
Cesar Rogelio Solorio Alvarado
DL: T. 1714-2011

At the printing of this manuscript, the results presented herein have yielded the publications presented below.

Cyclopropanation with Gold(I) Carbenes by Retro-Buchner Reaction from Cycloheptatrienes. César R. Solorio-Alvarado, Yahui Wang and Antonio M. Echavarren. *J. Am. Chem. Soc.* **2011**, *133*, 11952-11955.

Gold-Catalyzed Annulation/Fragmentation: Formation of Free Gold Carbenes by Retro- Cyclopropanation. César R. Solorio-Alvarado and Antonio M. Echavarren. *J. Am. Chem. Soc.* **2010**, *132*, 11881-11883.

Evolution of Propargyl Ethers into Allyl-Gold Cations in the Cyclization of Enynes.

E. Jiménez-Núñez, M. Raducan, T. Lauterbach, K. Molawi, César. R. Solorio, A. M. Echavarren, *Angew. Chem. Int. Ed.* **2009**, *48(33)*, 6152-6155.

UNIVERSITAT ROVIRA I VIRGILI
GOLD (I)-CATALYZED RETRO-CYCLOPROPANATION REACTION AND DEVELOPMENT OF TRINDANE-BASED
APPROACH TOWARD C60
Cesar Rogelio Solorio Alvarado
DL: T. 1714-2011

Index

Prólogo	i
Resumen	iii
General Objectives of the Thesis	vii
Introduction	1
I.1. Gold(I) as a Soft Lewis Acid	1
I.2. Relativistic Effects in the Chemical Nature of Gold	2
I.3. The π -Acidity of Gold(I) Complexes	4
I.4. Bonding Models for Gold(I) Complexes	5
I.5. Gold(I) Catalysts	8
I.6. General Transformations Catalyzed by Gold(I) Complexes	11
I.7. C ₆₀ , The Discovery and Genesis	27
CHAPTER I. Gold(I)-Catalyzed 1,6-Propargylic Migration of ethers	
Introduction	39
Results and Discussion	44
Conclusions of the Chapter	49
Experimental Section	50

CHAPTER II. Gold(I)-Catalyzed Annulation Via Retro-Cyclopropanation

Introduction	57
Results and Discussion	60
Conclusions of the Chapter	79
Experimental Section	80

CHAPTER III. Development of the Gold(I)-Catalyzed Retro-Buchner

Reaction

Introduction	163
Results and discussion	169
Conclusions of the chapter	184
Experimental Section	185

CHAPTER IV. The Trindane Approach to Polyarenes and Open Shell C60

Introduction	229
Results and discussion	234
Conclusions of the chapter	249
Experimental Section	250

General Conclusions of the Tesis	275
---	------------

Prologo

La presente disertación está dividida en 8 secciones: la primera de ellas es la redacción de un resumen escrito en castellano, la segunda es la presentación de los objetivos generales de la tesis. La siguiente sección es una introducción general y amplia, referente a los temas que se abordarán en el trabajo de investigación. Las siguientes cuatro secciones son los capítulos I, II, III y IV. Cada uno de ellos contiene la misma organización que consiste en una pequeña introducción referente al tema, los objetivos particulares de dicho capítulo, discusión de resultados y al final de cada capítulo se muestran las conclusiones particulares de dicho apartado. En la sección final de la memoria se enunciarán las conclusiones generales del trabajo de investigación.

1. En la sección del *resumen* se bosqueja de manera breve el contenido abarcado en cada una de los capítulos de la tesis.
2. Los objetivos generales de la tesis delimitan los alcances que se espera obtener durante el desarrollo del presente trabajo de investigación.
3. La introducción general de la tesis contiene información general detallada referente a cada uno de los temas que fueron investigados y que se discutirán en los capítulos I-IV.
4. En el capítulo I se describen los resultados obtenidos en la cicloisomerización de 1,7-eninos que contiene un anillo de benceno *orto* sustituido. Estos eninos contienen un éter metílico en la posición propargílica y un enol éter en el alqueno. El éter propargílico da lugar a una migración 1,6, seguido de una reacción tipo Nazarov, que origina sistemas con un núcleo tetracíclicos de benzo[*c*]fluoreno.

5. En el capítulo II, se estudian reacciones de 1,6-eninos. Aquí, al mantener la misma funcionalidad en el alquino y en la olefina tuvimos la ocasión de descubrir dos nuevos procesos catalíticos de anulación catalizado por complejos catiónicos de oro(I). En esta nueva reactividad, los aspectos a destacar son: 1) la fragmentación del enino de partida que tiene lugar durante el proceso de cicloisomerización y 2) la formación de un carbeno libre en solución mediante retro-ciclopropanación.
6. En el capítulo III se describe la generación de carbenos de oro(I) apartir de cicloheptatrienos mediante retrociclopropanación de los norcaradienos en equilibrio con los cicloheptatrienos y su utilización en la ciclopropanación de olefinas.
7. En el capítulo IV, se describe la síntesis de un posible precursor del fullereno C₆₀ que contiene todos los anillos de ciclopentano utilizando unidades de trindano (C₁₅) como precursor, el enfoque sintético resalta la convergencia que tiene como fragmento único el trindano. Además la escalabilidad de prácticamente todas las etapas de la síntesis así como la excelente solubilidad de todos y cada uno de los intermedios en disolventes de uso cotidiano en el laboratorio de química orgánica.
8. Finalmente se recogen las conclusiones generales de este trabajo de tesis doctoral.

UNIVERSITAT ROVIRA I VIRGILI
GOLD (I)-CATALYZED RETRO-CYCLOPROPANATION REACTION AND DEVELOPMENT OF TRINDANE-BASED
APPROACH TOWARD C60
Cesar Rogelio Solorio Alvarado
DL: T. 1714-2011

RESUMEN

UNIVERSITAT ROVIRA I VIRGILI
GOLD (I)-CATALYZED RETRO-CYCLOPROPANATION REACTION AND DEVELOPMENT OF TRINDANE-BASED
APPROACH TOWARD C60
Cesar Rogelio Solorio Alvarado
DL: T. 1714-2011

Resumen

La cicloisomerización de 1,5-, 1,6- y 1,7-eninos catalizada por Au(I) y Au(III) ha sido desarrollada con un enfoque sintético y mecanístico. Los aportes hechos hasta el momento nos han permitido elucidar de modo general la reactividad de los complejos catiónicos de oro(I) (Esquema R1).

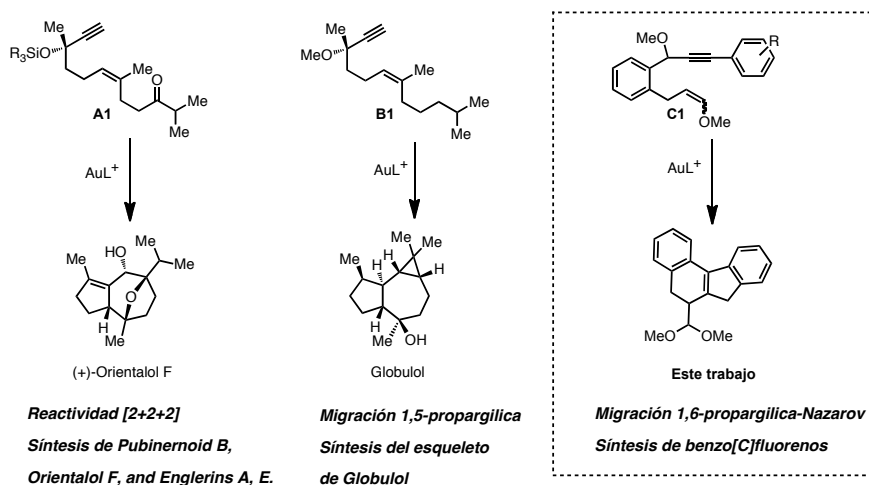

Esquema R1

Se demostró que en la ciclación de 1,6-eninos **B1**, la migración propargílica 1,5 del éter metílico tenía lugar originando la estructura base de los globuloles, una familia de productos naturales. Sin embargo al explorar la reactividad de 1,7-eninos **C1**, tuvo lugar una migración propargílica 1,6, dando lugar a la formación de benzo[C]fluorenos.

Alternativamente con una sustitución similar en los eninos de partida utilizando los 1,6-eninos **D1** (esquema R2) tuvo lugar una nueva reacción catalizada por oro. En este caso, un nuevo proceso de anulación catalizado por complejos catiónicos de oro(I) nos condujo a la formación de naftalenos 1,3-disustituídos **E1** (esquema R2).

Los naftalenos 1,3-disustituídos son una clase de compuestos no accesibles de manera convencional mediante acoplamiento cruzado o por sustitución electrófila aromática.

Durante el estudio de anulación con **D1**, determinamos el mecanismo de esta reacción. Encontramos que este proceso tiene lugar vía cicloisomerización 6-*endo-dig* generando un dihidronaftaleno **D2** (esquema R2), que tras migración [1,2] de hidrógeno genera **D3**. Tras protodemetalación, genera el enol eter **D4**. Retro-ciclopropanación sobre **D4** origina un naftaleno 1,3-bisustituído **E1**, junto con la formación de un carbeno libre de oro(I) **G1** para dar lugar a un bisciclopropano tetracíclico **F1**.

Esta es la primera vez que se observa el proceso de reto-ciclopropanación en química de oro. (Esquema R2).

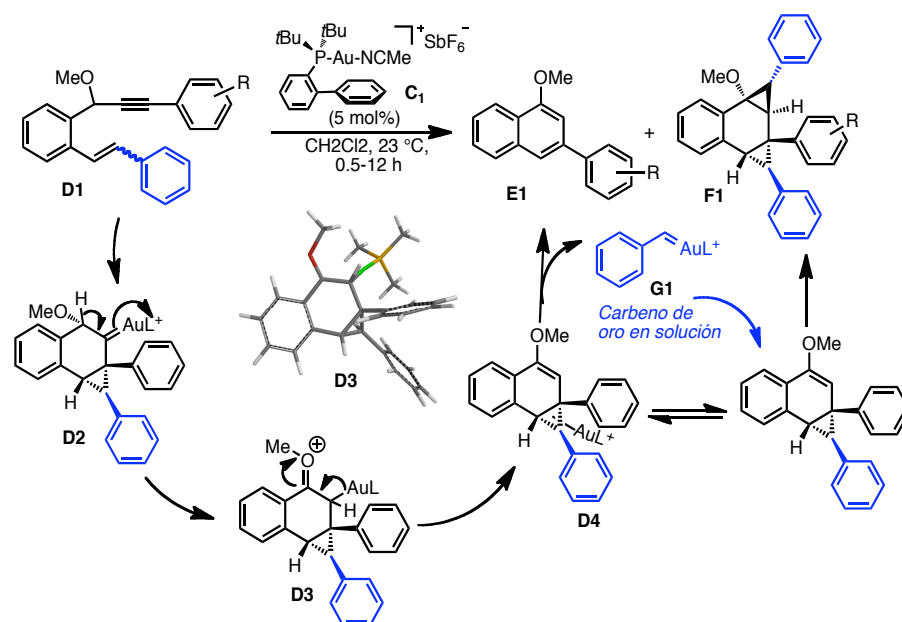

Esquema R2

Este descubrimiento nos planteó la posibilidad de generar carbenos libres y utilizarlos en la ciclopropanación de olefinas.

Este proceso se consiguió apartir de cicloheptatrienos (CHTs) que están en equilibrio con los correspondientes norcaradiene (NCDs) (Esquema R3).

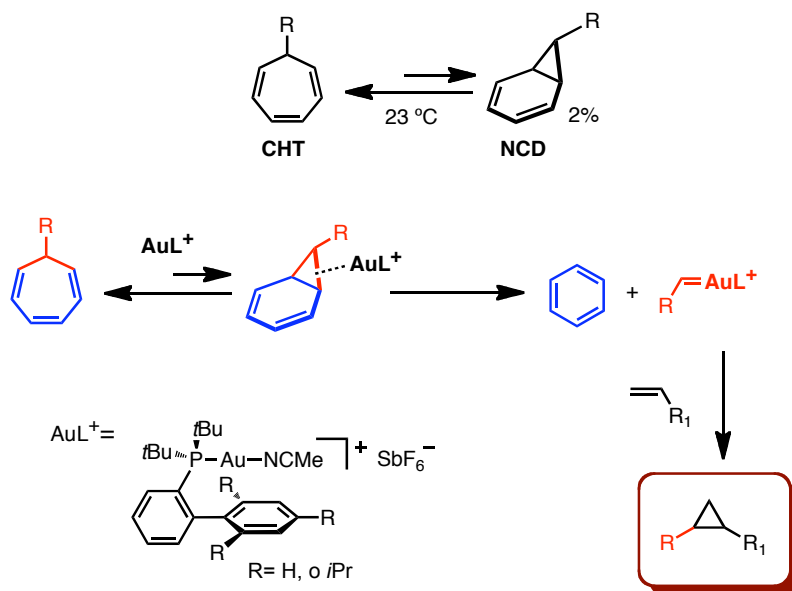

Esquema R3

De esta manera se logró sintetizar una familia de ciclopropanos bi- y trisustituidos con rendimientos buenos a excelentes. La reacción tolera muchos grupos funcionales y se puede realizar de forma intramolecular.

Por otro lado, en esta Tesis se desarrolló una metodología cuyo objetivo final es la síntesis del fullereno C₆₀, una molécula de gran relevancia en química de los materiales. Las síntesis del fullereno descritas hasta el momento, involucran secuencias con intermedios insolubles y etapas finales con condiciones drásticas como la pirólisis rápida a vacío FVP.

Nosotros nos planteamos la síntesis de un sistema abierto C₆₀ a partir del trindano (Esquema R5).

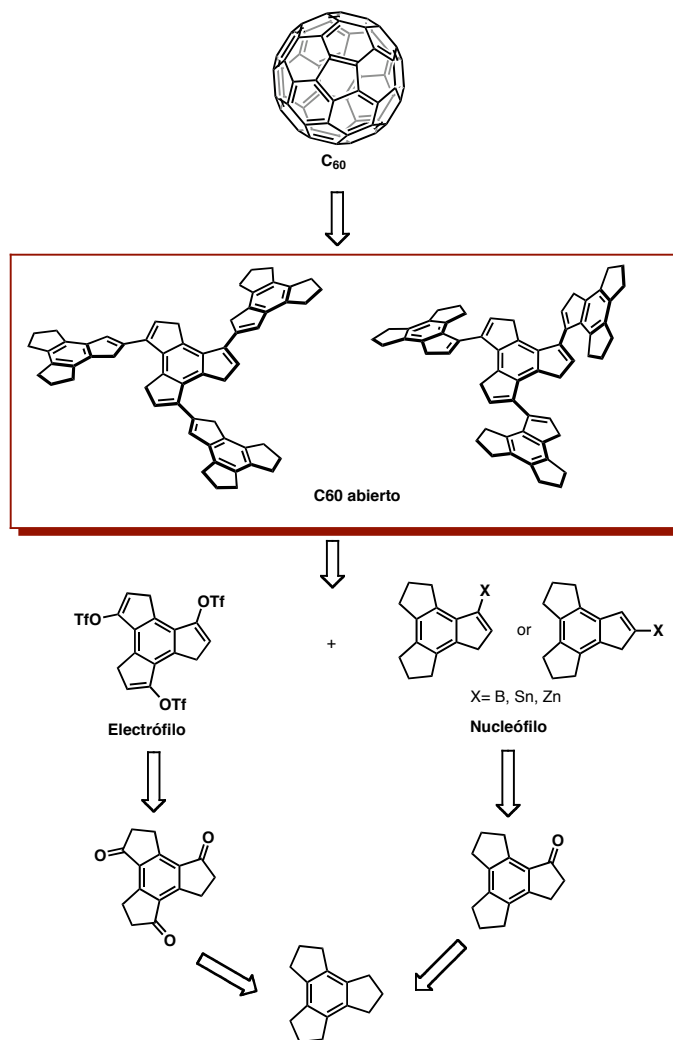

Esquema R5

Hasta el momento tal como se presenta en esta tesis, hemos sido capaces de seguir la ruta sintética mostrada (Esquema R5) y preparar el sistema C₆₀ abierto. Experimentos futuros serán realizados y se enfocarán en la formación de los enlaces necesarios para obtener el fullereno C₆₀.

GENERAL OBJECTIVES OF THE TESIS

This work focused on the study of novel reactions catalyzed by cationic gold(I) complexes as well as their application in the synthesis of new organic molecules. On the other hand, we wished to develop a synthesis of an open shell C60 molecule with all of the pentagons of fullerene C₆₀ using trindane derivatives as the building blocks.

Specifically we aimed at addressing the following objectives in gold(I) catalysis:

- The study of the cycloisomerization 1,6- and 1,7-enynes bearing aryl groups at the alkyne and/or the alkene catalyzed by cationic gold(I) complexes.
- The elucidation of the reaction mechanism of the gold(I)-catalyzed cycloisomerization of substituted 1,6- and 1,7-enynes.

Regarding the synthesis of an open model system of fullerene C60, the specific objectives of this work were:

- Development of a synthesis of 1,4,7-trindanetrione and its tris-triflate that could furnish gram amounts of these materials.
- The development of a Suzuki-based synthesis of aryltrindanes with C_{3v} symmetry.
- The development of a convergent synthesis of an open shell C60 molecule with all of the pentagons of fullerene C₆₀ using trindane derivatives as the building blocks.

UNIVERSITAT ROVIRA I VIRGILI
GOLD (I)-CATALYZED RETRO-CYCLOPROPANATION REACTION AND DEVELOPMENT OF TRINDANE-BASED
APPROACH TOWARD C60
Cesar Rogelio Solorio Alvarado
DL: T. 1714-2011

UNIVERSITAT ROVIRA I VIRGILI
GOLD (I)-CATALYZED RETRO-CYCLOPROPANATION REACTION AND DEVELOPMENT OF TRINDANE-BASED
APPROACH TOWARD C60
Cesar Rogelio Solorio Alvarado
DL: T. 1714-2011

GENERAL INTRODUCTION

UNIVERSITAT ROVIRA I VIRGILI
GOLD (I)-CATALYZED RETRO-CYCLOPROPANATION REACTION AND DEVELOPMENT OF TRINDANE-BASED
APPROACH TOWARD C60
Cesar Rogelio Solorio Alvarado
DL: T. 1714-2011

Introduction

The pioneering work of Fukuda and Utimoto in 1991^{1,2} on the addition of water and alcohols to alkynes demonstrated the potencial of gold as catalyst in organic synthesis. However it was not until 1997 with the work of Teles³ using cationic gold(I) complexes that scientific community started to turn the attention towards the chemistry of gold.

I.1. Gold(I) as a Soft Lewis Acid.

Formulated in 1923 by Lewis as part of the electron-pair theory of acid-base,^{4,5} an acid is a chemical specie with empty orbitals capable to accept pairs of electrons. This general concept embeds a broad range of substances, describing properly their electronic nature in terms of chemical bond.

In 1963 Pearson introduced the concept of hard and soft Lewis acid and bases (HSAB).⁶ In agreement with HSAB, a hard Lewis acid is a chemical species with a small ionic or atomic radius, highly charged and weakly polarizable. While a soft Lewis acid posseses a big radio, has a low charge and is strongly polarizable.^{7,8}

1 Fukuda, Y.; Utimoto, K. *J. Org. Chem.* **1991**, *56*, 3729-3733.

2 Fukuda, Y.; Utimoto, K. *Bull. Chem. Soc. Jpn.* **1991**, *56*, 3729-3733.

3 Teles, J. H.; Brode, S.; Chabanas, M. *Angew. Chem. Int. Ed.* **1998**, *37*, 1415-1418.

4 Lewis, G. N. *J. Frank. Inst.* **1938**, *226*, 293-313.

5 Ebbing, D. D., Gammon, S. D. *General Chemistry* 8th ed. Boston, MA: Houghton Mifflin. **2005**.

6 Pearson, R. G. *J. Am. Chem. Soc.* **1963**, *85*, 3533-3539.

7 Pearson, R. G. *J. Chem. Educ.* **1968**, *45*, 581-586.

8 Pearson, R. G. *J. Chem. Educ.* **1968**, *45*, 643-648.

According to these theories gold(I) and gold(III) can be defined as *soft Lewis acids* (Figure I.1).

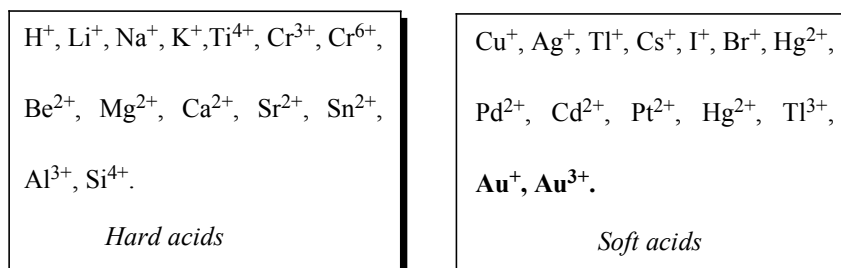

Figure I.1. Examples of hard and soft Lewis acids.

I.2. Relativistic Effects in the Chemical Nature of Gold.

As any transition metal of the sixth period, the nuclear charge in gold is high and it shows the *relativistic effects*. Relativistic effects, can be defined as irregular periodic behavior resulting from the high velocity of the internal shell electrons traveling at close to the speed of light.^{9,10} In the case of heavy atoms with large atomic radius, the Schrödinger equation¹¹ has to be modified¹² considering the relativistic effects. To describe more realistically the shape of the more external and valence orbitals as well as the consequent reactivity can be properly expressed.

Theoretically, the chemistry of gold has been well reviewed,^{13,14,15} and the most relevant characteristics of its electronic structure can be understood as the result

9 Pitzer, K. S. *Acc. Chem. Res.* **1979**, *12*, 272-276.

10 McKelvey, D. R. *J. Chem. Educ.* **1983**, *60*, 112-116.

11 Schrödinger, E. *Phys. Rev.* **1926**, *26*, 1049-1070.

12 Dirac, P. A. M. *Proc. R. Soc.* **1928**, *117*, 610-624.

13 Pyykkö, P. *Angew. Chem. Int. Ed.* **2004**, *43*, 4412-4456.

14 Pyykkö, P. *Inorg. Chim. Acta.* **2005**, *358*, 4113-4130.

15 Gorin D.; Toste, F. D. *Nature* **2007**, *446*, 395-403.

of the strong relativistic effects. For gold, relativistic effects are mainly manifested in 1) the contraction of external 6s and 6p orbitals and 2) expansion of the 5d orbitals (Figure I.2).

These resulting effects have some experimentally observed consequences, which are briefly summarized here:

- *Contraction of external 6s and 6p orbitals.* As result of contracted 6s and 6p orbitals, the bond between gold is stronger. Additionally cationic gold(I) exhibits superior Lewis acidity in comparison with other cationic metals of group 11. Another interesting property present in gold, originated by this relativistic effect is the unusual high electronegativity of 2.5,¹⁶ compared with 2.4 for carbon. This would imply that in a C-Au bond the majority of bonding electron density would be located in gold, and not in carbon, as expected based on electronegativity trends which neglect the relativistic effects.
- *Expansion of 5d orbitals.* The expansion of these orbitals in gold causes a diffuse electronic cloud, diminishing the electron-electron repulsions, resulting in a very high first ionization energy (9.22 eV).¹⁷ This effect is relevant in catalysis because as a corollary of this relativist effect, the oxidative addition of gold(I) to form gold(III) is not a facile process and usually does not take place. Another important result caused by expansion of the 5d orbitals, is the gold-carbenoid behavior. Here the diffuse 5d electrons are delocalized into carbon-based orbitals of low enough energy, especially in the empty π orbital of the carbocation.¹⁸

¹⁶ Electronegativity is given in Pauling scale.

¹⁷ Neale, R. S. *J. Phys. Chem.* **1964**, *68*, 143–146.

¹⁸ Shapiro, N. D.; Toste, F. D. *Synlett* **2010**, *5*, 675-691.

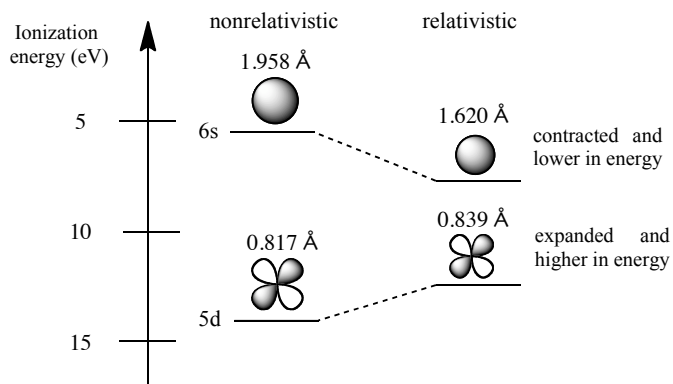

Figure I.2. Comparison of calculated sizes and energies of the 6s and 5d orbitals of gold with and without considerations of relativistic effects.

I.3. The π -Acidity of Gold(I) Complexes.

The main characteristic of cationic gold(I) complexes in catalysis is the high affinity showed towards alkynes, allenes and alkenes. Representative examples of well characterized gold(I) complexes with unsaturated π -bond ligands include the following:

Gold(I)-[2]-catenane containing a linear (η^1 -alkyne)-Au-(η^2 -alkyne) (scheme I.3, A),¹⁹ examples of coordination to organometallic 1,4-diyne in a trigonal planar gold complexes,²⁰ supramolecular complex containing a linear (η^2 -alkyne)-Au-(η^2 -alkyne) (scheme I.3, B),²¹ linear N-heterocyclic carbene-Au-(η^2 -alkyne) (scheme I.3, C),²² coordination to arenes in linear phosphine-Au-(η^2 -arene)

19 Mingos, D. M. P.; Yau, J.; Menzer, S.; Williams, D. J. *Angew. Chem. Int. Ed.* **1995**, *34*, 1894-1895.

20 Lang, H.; Köhler, K.; Zsolnai, L. *Chem Commun.* **1996**, 2043-2044.

21 Yip, S.; Cheng, E. C.; Yuan, L.; Zhu, N.; Yam, V. W. *Angew. Chem. Int. Ed.* **2004**, *43*, 4954-4957.

22 Akana, J. A.; Bhattacharyya, K. X.; Müller, P.; Sadighi, J. P. *J. Am. Chem. Soc.* **2007**, *129*, 7736-7737.

complexes (scheme I.3, D),²³ and $[\text{Au(I)-phosphine-(}\eta^2\text{-alkyne)}]_2$ as well as $[\text{Au(I)-phosphine-(}\eta^2\text{-alkene)}]_2$ complexes (scheme I.3, E).²⁴

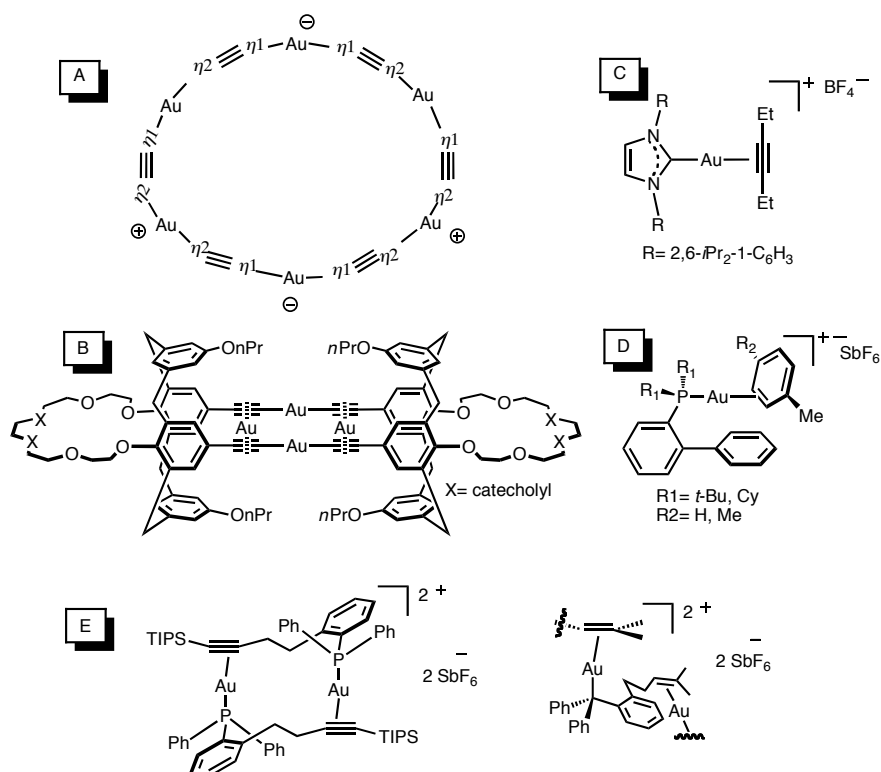

Scheme I.3. Representative examples of synthesized gold(I)- π -alkyne and alkene complexes.

I.4. Bonding Models for Gold(I) Complexes.

The Dewar-Chatt-Duncanson (DCD) is the most basic molecular orbital model that explains the interaction between metals and π -bonded unsaturated ligands.

23 a) Herrero-Gómez, E.; Nieto-Oberhuber, C.; López, S.; Benet-Buchholz, J.; Echavarren, A. M. *Angew. Chem. Int. Ed.* **2006**, *45*, 5455 – 5459. b) Pérez-Galán, P.; Delpont, N.; Herrero-Gómez, E.; Maseras, F.; Echavarren, A. M. *Chem. Eur. J.* **2010**, *16*, 5324-5332.

24 Shapiro, N. D.; Toste, F. D. *Proc. Nat. Acad. Sci. U.S.A.* **2008**, *105*, 2779-2782.

The model was originally described 1951 for Dewar²⁵ based on the perturbation theory^{26,27} of the quantum mechanics to describe this complicated quantum system. The importance of his model lies in the introduction of the metal-ligand orbital interactions concept. Latter Chatt and Duncanson in 1953²⁸ used the Dewar's model for a systematic description of metal-olefin complexes.

Essentially the DCD model applied to the gold(I)-alkyne interaction specify:

1. A σ -donation resulting from the interaction between a filled π orbital of the alkyne and an empty d orbital of the metal, and
2. A back-donation from a filled d orbital of the metal to an anti-bonding orbital π^* of the alkyne. (Scheme I.4.1, A).

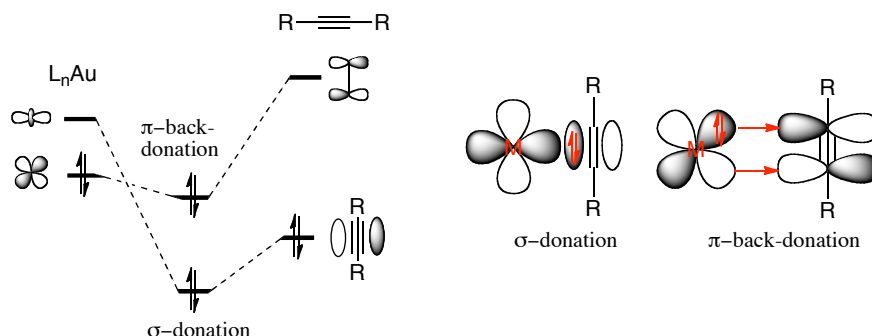

Scheme I.4.1. The Dewar-Chatt-Duncanson model showing the σ -donation and π -back-donation in a gold-alkyne complex.

Density functional theory (DFT) calculations carried out by Toste²⁴ using second order perturbative analysis of natural bond orbitals (NBO), show that the σ -donation from the alkyne π -bond to the metal as the main bonding interaction (56.6 Kcal/mol), being responsible of the increasing electrophilicity of the triple bond.

25 Dewar, M. J. S. *Bull. Soc. Chim. Fr.* **1951**, 18, C71.

26 Schrödinger, E. *Annalen der Physik* **1926**, 80, 437-490.

27 Fhelnher, T. P. *J. Organomet. Chem.* **2001**, 635, 92-99.

28 Chatt, J.; Duncanson, L. A. *J. Chem. Soc.* **1953**, 2939-2947.

However this is not the only interaction, the analysis of frontier molecular orbitals illustrates a back-donation from the metal to the π^* orbital of the alkyne, which is energetically important (13.3 Kcal/mol), is to say the LUMO contains the back-donation. These bonding interactions are responsible for the superior Lewis acidity of Au(I) in comparison with the rest of the transition metals.²⁴

In summary, the π -acidity of gold(I) complexes towards alkynes, is supported by the strong σ -donation of alkyne π -bond (56.6 Kcal/mol) as well as the back-donation (13.3 Kcal/mol). Additional studies of complexes containing other π -bond ligands confirm the evidence of this strong π -affinity.²⁹

According to this, donation and back-donation tend to reduce the C-C bond order in the alkyne, leading to an elongated C-C distance and generating a three-center two bonds system related to a metallacyclopropene.²⁹

Some other theoretical models for gold-alkyne coordination have been described.³⁰ One of them, developed by Toste and Goddard describes a bonding model for the ligand-gold-carbene (LGC) system.³¹ They found that the gold-C bond is essentially composed of a π -type bond, however the back-donation from metal to carbene is highly dependent on the carbene substituents. They divided the LGC in three components, 1) σ -bonding from carbene and ligand to metal, 2) π -bonding from metal to carbene and 3) π -bonding from metal to ligand (Scheme 1.4.2).

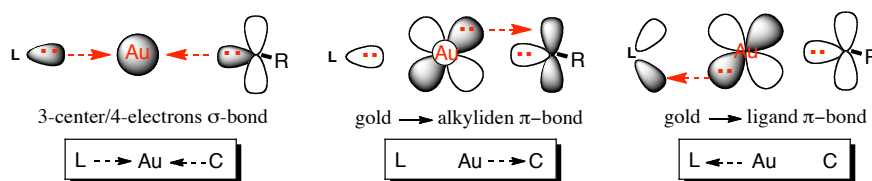

Scheme 1.4.2. Bonding model for gold(I)-carbene complexes.

29 a) Elschenbroich, C. *Organometallics*, 3th ed. Weinheim, Germany, WILEY-VCH Verlag GmbH & Co. KGaA, **2006**. b) Schmidbaur, H.; Schier, A. *Organometallics* **2010**, *29*, 2-23.

30 Salvi, N.; Belpassi, L.; Tarantelli, F. *Chem. Eur. J.* **2010**, *16*, 7231 – 7240.

31 Benitez, D.; Shapiro, N. D.; Tkatchouk, E.; Wang, Y.; Godarr III, W. A.; Toste, F. D *Nat. Chem.* **2009**, *1*, 482-486.

The σ -bonding is mainly composed of a three-center/four-electrons interaction. The π -bonding consists on the electron donation of two orthogonal d orbitals from gold into π -acceptor orbitals on the ligand and on the carbene. With this model it is possible to predict the effect that substituents can have on the carbene, and as a consequence the reactivity that will be observed. The conclusion of this model is that the reactivity for a gold(I)-carbenes interaction is best described as intermediates between metal-stabilized singlet carbene to a metal coordinated-carbocation. The relative importance of each component will be determined by the carbene substituents and the ancillary ligand.

1.5. Gold(I) Catalysts.

Gold-catalyzed reactions are novel organometallic transformations originally carried out by a simple gold(III) salts like NaAuCl_4 .^{1,2} However the instability of this salt towards reduction, leads to poor TON and low yields, making it an inappropriate catalyst. Other commercially gold(III) salts like AuCl_3 and AuBr_3 are catalytically active although they are hygroscopic, light sensitive and decompose at temperatures above 160 °C, producing molecular halogen and metallic gold (scheme I.5.1).³²

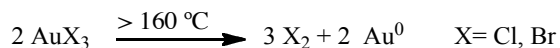

Scheme I.5.1. Thermal decomposition of gold(III) halides.

Gold(I) salts such as AuCl , AuBr or AuI , have been prepared by reduction of the parent gold(III) compounds. These salts show catalytic activity, notwithstanding

32 Wiber, E.; Wiber, N.; Holleman, A. F. *Inorganic Chemistry* 101 ed, Academic Press, **2001**, 1286-1287.

they suffer redox disproportionation to give gold(III) and elemental gold (scheme I.5.2).³³



Scheme I.5.2. Disproportionation of Gold(I) halides.

It is worth to mention that gold(I) complexes adopt a linear coordination geometry.³⁴ Phosphines, phosphites and related donor ligands forms lineal L-Au-X complexes. The 14 electron complexes of the type **I-IV**, **X**, and **XII-XX** (Figure I.5), show a poor catalytic activity in comparison with cationic complexes **V-IX**, **XI** and **XVI-XX** (Figure I.5). These cationic forms are generated by abstraction of the halogen, typically by using one equivalent of a Ag(I) salt with a non-coordinating anion.³⁵ Thus, complexes with the general formula [Au(S)(P)]X (P = phosphine ligand, S = solvent molecule, X = non-coordinating anion) are easily generated. These complexes have the advantage that they do not need to be activated, are soluble in the reaction media, and are stable in the solid state. To date various cationic gold(I) complexes have been synthesized. Among them, we can find complexes with bulky-biphenyl based phosphines as ligands, which were originally developed for Pd-catalyzed cross coupling.³⁶ The corresponding gold complexes are very active catalysts upon mixing with Ag(I) salts (scheme I.5, I-

33 Pradyot Patnaik. *Handbook of Inorganic Chemicals*. McGraw-Hill, **2002**.

34 For discussion about the choice of coordination number in d10 complexes of group 11 metals, see: Carvajal, M. A.; Novoa, J. J.; Álvarez, S. *J. Am. Chem. Soc.* **2004**, *126*, 1465–1477.

35 (a) Nieto-Oberhuber, C.; Muñoz, M. P.; Buñuel, E.; Nevado, C.; Cárdenas, D. J.; Echavarren, A. M. *Angew. Chem. Int. Ed.* **2004**, *43*, 2402-2406. (b) Nieto-Oberhuber, C.; Muñoz, M. P.; López, S.; Jiménez-Núñez, E.; Nevado, C.; Herrero-Gómez, E.; Raducan, M.; Echavarren, A. M. *Chem. Eur. J.* **2006**, *12*, 1677-1693. (c) Ferrer, C.; Raducan, M.; Nevado, C.; Claverie, C. K.; Echavarren, A. M. *Tetrahedron* **2007**, *63*, 6306-6316.

36 (a) Kaye, S.; Fox, J. M.; Hicks, F. A.; Buchwald, S. L. *Adv. Synth. Catal.* **2001**, *343*, 789-794. (b) Walker, S. D.; Barder, T. E.; Martinelli, J. R.; Buchwald, S. L. *Angew. Chem. Int. Ed.* **2004**, *43*, 1871-1876. (c) Strieter, E. R.; Blackmond, D. G.; Buchwald, S. L. *J. Am. Chem. Soc.* **2003**, *125*, 13978-13980. (d) Barder, T. E.; Walker, S. D.; Martinelli, J. R.; Buchwald, S. L. *J. Am. Chem. Soc.* **2005**, *127*, 4685-4696. (e) Barder, T. E.; Buchwald, S. L. *J. Am. Chem. Soc.* **2007**, *129*, 5096-5101.

VI).³⁷ Related complexes containing a labile bis(trifluoromethanesulfonyl)amide (NTf₂) as ligand have been reported showing similar properties.³⁸

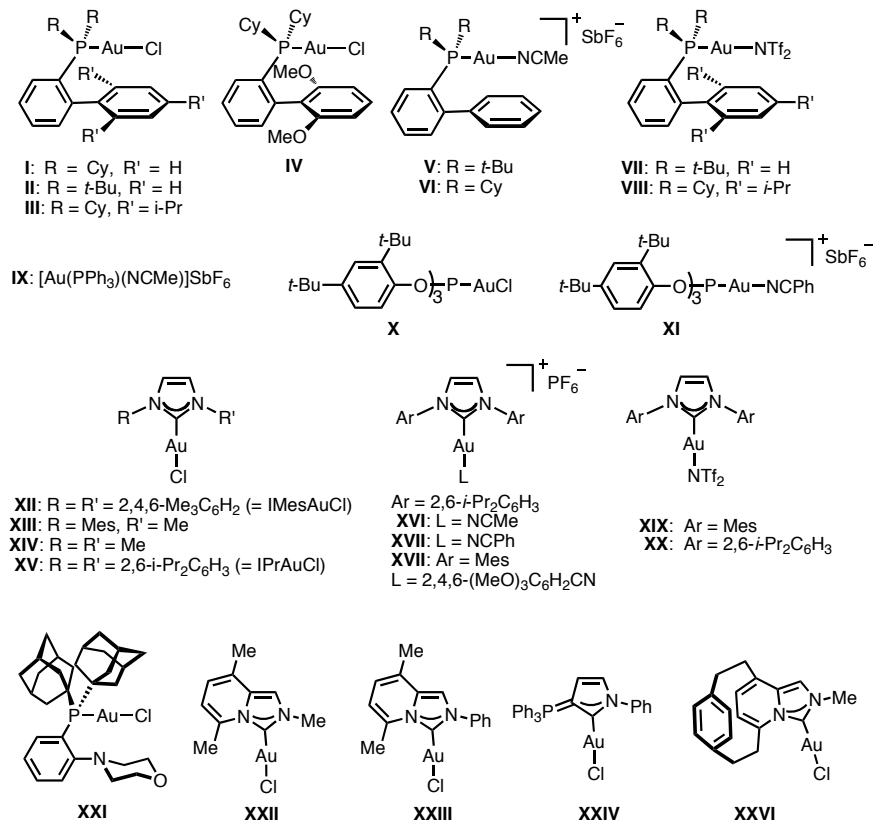

Figure I.5. Representative neutral and cationic gold(I) complexes.

The bulky bis-adamantyl phosphine ligand in complex **XXI** has been synthesized for the use in hydroaminations of alkynes with dialkylamines.³⁹ Phosphite

37 Structures **I-V** were confirmed by X-ray crystallography, see ref. 23a. (b) Partyka, D. V.; Robilotto, T. J.; Hunter, A. D.; Gray, T. G. *Organometallics* **2008**, *27*, 28-32.

38 Mézailles, N.; Ricard, L.; Gagosz, F. *Org. Lett.* **2005**, *7*, 4133-4136.

39 Hesp, K. D.; Stradiotto, M. *J. Am. Chem. Soc.* **2010**, *132*, 18026-18029.

complex **X**⁴⁰ bearing tris(2,6-di-*tert*-butylphenyl)phosphite as the ligand, as well as its cationic counterpart **XI**,⁴¹ are particularly highly electrophilic Au(I) catalysts. Complexes containing strongly σ -donating N-heterocyclic carbenes (NHC) **XII-XV** are useful precatalysts.^{42,43,44,45} NHC complexes **XXII-XV** have been synthesized to study their π -acceptor properties.⁴⁶ Cationic NHC complexes **XVI-XVIII**^{41,47} and those bearing labile ligands such as NTf₂ **XX-XXI** have also been described.⁴⁸

1.6. General Transformations Catalyzed by Gold(I) Complexes.

The most important characteristic of gold(I) complexes in catalysis is their high affinity towards alkynes. Upon complexation, this strong interaction allows the addition of weak nucleophiles such as water and methanol, by activation of the triple bond. Even though this type of reaction can also be catalyzed by

40 (a) López, S.; Herrero-Gómez, H.; Pérez-Galán, P.; Nieto-Oberhuber, C.; Echavarren, A. M. *Angew. Chem. Int. Ed.* **2006**, *45*, 6029-6032. (b) **X** structure was confirmed by X-Ray crystallography: Nieto-Oberhuber, C.; Pérez-Galán, P.; Herrero-Gómez, E.; Lauterbach, T.; Rodríguez, C.; López, S.; Bour, C.; Rosellón, A.; Cárdenas, D. J.; Echavarren, A. M. *J. Am. Chem. Soc.* **2008**, *130*, 269-279.

41 Amijs, C. H. M.; López-Carrillo, V.; Raducan, M.; Pérez-Galán, P.; Ferrer, C.; Echavarren, A. M. *J. Org. Chem.* **2008**, *73*, 7721-7730.

42 Nieto-Oberhuber, C.; López, S.; Echavarren, A. M. *J. Am. Chem. Soc.* **2005**, *127*, 6178-6179.

43 (a) Deetlefs, M.; Raubenheimer, H. G.; Esterhuysen, M. W. *Cat. Today.* **2002**, *72*, 29-41. (b) Schneider, S. K.; Herrmann, W. A.; Herdtrweck, E. *Z. Anorg. Allg. Chem.*, **2002**, *629*, 2363-2370.

44 de Frémont, P.; Scott, N. M.; Stevens, E. D.; Nolan, S. P. *Organometallics* **2005**, *24*, 2411-2418.

45 For NHC-Au(III) complexes see: de Frémont, P.; Singh, R.; Stevens, E. D.; Petersen, J. L.; Nolan, S. P. *Organometallics* **2007**, *26*, 1376-1385.

46 Alcarazo, M.; Stork, T.; Anoop, A.; Thiel, W.; Fürstner, A. *Angew. Chem. Int. Ed.* **2010**, *49*, 2542-2546.

47 de Frémont, P.; Stevens, E. D.; Fructos, M. R.; Diaz-Requejo, M. M.; Perez, P. J.; Nolan, S. P. *Chem Commun* **2006**, 2045-2047.

48 Li, G.; Zhang, L. *Angew. Chem. Int. Ed.* **2007**, *46*, 5156-5159.

mercury(II),⁴⁹ the highly toxicity of this method and low TON severely limited their opportunity in synthesis.

I.6.1. Gold(I)-Catalyzed Addition of Heteronucleophiles to Alkynes.

Various examples of addition of heteronucleophiles containing oxygen,^{1,2,3,50,51} nitrogen,^{52,53,54} sulfur,^{55,56} fluorine,⁵⁷ as well as sulfoxides,⁵⁸ imines,⁵⁹ azides⁶⁰ or amines⁶¹ toward alkynes have been documented,⁶² both intra- and intermolecularly (scheme I.6.1.1).

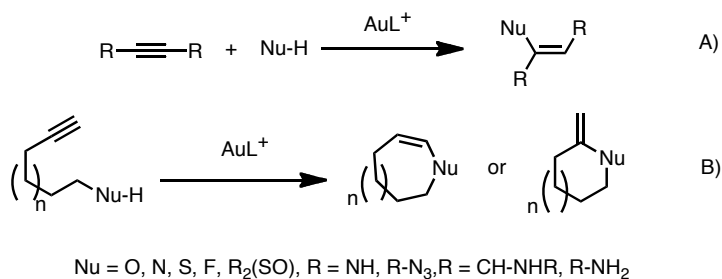

Scheme I.6.1.1. Addition of heteronucleophiles A) inter- and B) intramolecularly.

49 Reichert, J. S.; Bailey, J. H.; Niewland, J. A. *J. Am. Chem. Soc.* **1923**, *45*, 1553-1557.

50 Antoniotti, S.; Genin, E.; Michelet, V.; Genet, J.-P. *J. Am. Chem. Soc.* **2005**, *127*, 9976-9978.

51 Genin, E.; Toullec, P. Y.; Antoniotti, S.; Brancour, C.; Genet, J.-P.; Michelet, V. *J. Am. Chem. Soc.* **2006**, *128*, 3112-1114.

52 Fukuda, Y.; Utimoto, K.; Nozaki, H. *Heterocycles* **1987**, *25*, 297-300.

53 Mizushima, E.; Hayashi, T.; Tanaka, M. *Org. Lett.* **2003**, *5*, 3349-3353.

54 Zhang, Y. H.; Donahue, J. P.; Li, C. *J. Org. Lett.* **2007**, *9*, 627-630.

55 Nakamura, I.; Sato, T.; Yamamoto, Y. *Angew. Chem., Int. Ed.* **2006**, *45*, 4473-4475.

56 Nakamura, I.; Sato, T.; Terada, M.; Yamamoto, Y. *Org. Lett.* **2007**, *9*, 4081-4803.

57 Akana, J. A.; Bhattacharyya, K. X.; Muller, P.; Sadighi, J. P. *J. Am. Chem. Soc.* **2007**, *129*, 7736.

58 (a) Shapiro, N. D.; Toste, F. D. *J. Am. Chem. Soc.* **2007**, *129*, 4160-4161. (b) Davies, P. W.; Albrecht, S. J.-C. *Angew. Chem. Int. Ed.* **2009**, *48*, 8372-8375.

59 Kusama, H.; Miyashita, Y.; Takaya, J.; Iwasawa, N. *Org. Lett.* **2006**, *8*, 289-292.

60 Gorin, D. J.; Davis, N. R.; Toste, F. D. *J. Am. Chem. Soc.* **2005**, *127*, 11260-11261.

61 (a) Mizushima, E.; Hayashi, T.; Tanaka, M. *Org. Lett.* **2003**, *5*, 3349-3352. (b) Istrate, F. M.; Gagosz, F. *Org. Lett.* **2007**, *9*, 3181-3184.

62 Li, Z.; Brower, C.; He, C. *Chem. Rev.* **2008**, *108*, 3239-3265.

The general mechanism of this reaction has been studied (scheme I.6.1.2).⁶³

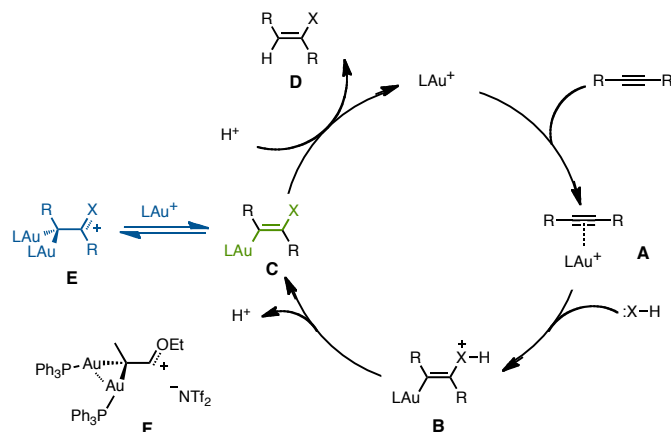

Scheme I.6.1.2. Mechanism of heteronucleophile addition to alkynes.

The process starts by coordination to alkyne to generate π -complex **A**. Stereoselective nucleophilic *trans*-attack forms intermediate **B**. Loss of H^+ give rise to **C** which is followed by rapid protodeauration to releases product **D** and regenerates the catalyst. An alternative reaction pathway involving intermediate **C** would generate *gem*-diaurated species such as **E** that could compete with protodeauration. Thus compound **F** could be isolated and characterized by NMR and X-ray crystallography (scheme 1.6.1.2).

I.6.2. Cyclization of Enynes.

Cycloisomerization of enynes has been extensively studied in recent years.⁶⁴

63 Seidel, G.; Lehmann, C. W.; Fürstner, A. *Angew. Chem. Int. Ed.* **2010**, *49*, 8466-8470.

64 a) Jiménez-Núñez, E.; Echavarren, A. *Chem. Rev.* **2008**, *108*, 3326-3350. (b) Gorin, D. J.; Sherry, B. D.; Toste, F. D. *Chem. Rev.* **2008**, *108*, 3351-3378. (c) Michelet, V.; Toullec, P. Y.; Genêt, J.-P. *Angew. Chem. Int. Ed.* **2008**, *47*, 4268-4315. (d) Fürstner, A. *Chem. Soc. Rev.* **2009**, *38*, 3208-3221.

The first example was reported in 1976 by Ohloff using $ZnCl_2$ in the cyclization of propargylic acetates (scheme I.6.2.1).⁶⁵

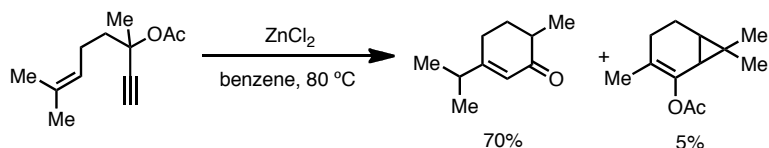

Scheme I.6.2. Zinc-catalyzed cyclization of 1,6-enyne with propargylic acetate.

I.6.2.1. Cyclization of 1,5-Enynes.

Among the most extensively studied gold(I)-catalyzed reactions, are the cycloisomerization of enynes.⁶⁶ The oriented structural complexity, atom-economy and high yielding reactivity, makes them useful starting materials. In presence of electrophilic metals 1,*n*-enynes (*n* = 5-7) undergo cycloisomerization resulting in addition products if a nucleophile is present, whereas skeletal rearrangement occurs in its absence. Systematic studies varying the chemical skeletons of both alkynes and the alkenes in the enyne provide the main features, stereochemical outcomes and reaction pathways.^{40b,66}

Cyclization of 1,5,^{41,67,68} 1,6-^{35b} and 1,7-enynes^{67,69} have been widely studied and applied in different areas of the chemistry.

65 Stickler, H.; Davis, J. B.; Ohloff, G. *Helv. Chim. Acta* **1976**, *59*, 1328–1332.

66 Jiménez-Núñez, E.; Claverie, C. K.; Bour, C.; Cardenas, D. J. *Angew. Chem. Int. Ed.* **2008**, *47*, 7892-7895.

67 Luzung, M. R.; Markham, J. P.; Toste, F. Dean. *J. Am. Chem. Soc.* **2004**, *126*, 10858-10859.

68 Kirsch, S. F.; Binder, J. T.; Crone, B.; Duschek, A.; Haug, T. T.; Litbert, C.; Menz, H. *Angew. Chem. Int. Ed.* **2007**, *46*, 2310-2313.

69 Cabello, N.; Rodríguez, C. *Synlett* **2007**, *11*, 1753-1758.

Different substitution pattern of the starting enyne, as well as the nature of the catalyst, influences significantly the reactivity of the cycloisomerization process.

Thus, 1,*n*-enyne react in the presence of different metals like Pd,⁷⁰ Ru,⁷¹ Rh,⁷² Pt,^{71b,73} or Co⁷⁴ to furnish several types of carbo- and heterocyclic products. In the following section will be comment on the most representative cyclizations catalyzed by gold(I).

Several transformations involving cyclization of 1,5-enynes are documented. Among the most representatives are the cycloisomerizations,^{75,76} and some of its variants like those involving migration of acetates^{77,78} or trapping of the intermediate gold(I) carbene with a nucleophile.^{79,80}

70 (a) Trost, B. M.; Lautens, M. *J. Am. Chem. Soc.* **1985**, *107*, 1781-1783. (b) Trost, B. M.; Lautens, M. *Tetrahedron Lett.* **1985**, *26*, 4887-4890. (c) Trost, B. M.; Chen, S.-F. *J. Am. Chem. Soc.* **1986**, *108*, 6053-6054. (d) Trost, B. M.; Lautens, M.; Chan, C.; Jebaratnam, D. S.; Mueller, T. *J. Am. Chem. Soc.* **1991**, *113*, 636-644. (e) Trost, B. M.; Gelling, O. J. *Tetrahedron Lett.* **1993**, *34*, 8233-8236. (f) Wartenberg, F.-H.; Hellendahl, B.; Blechert, S. *Synlett* **1993**, 539-540. (g) Castro, J.; Balme, G.; Goré, J. *J. Chem. Res.* **1995**, 504-505.

71. (a) Paih, J. L.; Rodriguez, D. C.; Dérien, S.; Dixneuf, P. H. *Synlett* **2000**, 95-97. (b) Méndez, M.; Muñoz, M. P.; Nevado, C.; Cárdenas, D. J.; Echavarren, A. M. *J. Am. Chem. Soc.* **2001**, *123*, 10511-10520.

72(a) Cao, P.; Wang, B.; Zhang, X. *J. Am. Chem. Soc.* **2000**, *122*, 6490-6491. (b) Cao, P.; Zhang, X. *Angew. Chem. Int. Ed.* **2000**, *39*, 4104-4106.

73(a) Méndez, M.; Muñoz, M. P.; Echavarren, A. M. *J. Am. Chem. Soc.* **2000**, *122*, 11549-11550. (b) Muñoz, M. P.; Méndez, M.; Nevado, C.; Cárdenas, D. J.; Echavarren, A. M. *Synthesis* **2003**, 2898-2902.

74. Borodkin, V. S.; Shapiro, N. A.; Azoz, V. A.; Krochetkov, N. K. *Tetrahedron Lett.* **1996**, *37*, 1489-1492.

75 Luzung, M. R.; Markham, J. P.; Toste, F. D. *J. Am. Chem. Soc.* **2004**, *126*, 10858-10859.

76 Gagosz, F. *Org. Lett.* **2005**, *7*, 4129-4132.

77 Zhang, L.; Wang, S. *J. Am. Chem. Soc.* **2006**, *128*, 14274-14275.

78 Marion, N.; de Frémont, P.; Lemièrre, G.; Steves, E. D.; Fensterbank, L.; Malacria, M.; Nolan, S. P. *Chem. Commun.* **2006**, 2048-2050.

79 Buzas, A. K.; Istrate, F. M.; Gagosz, F. *Angew. Chem. Int. Ed.* **2007**, *46*, 1141-1144.

80 Amjis, C. H. M.; López-Carrillo, V.; Raducan, M.; Pérez-Galán, P.; Ferrer, C.; Echavarren, A. M. *J. Org. Chem. J. Org. Chem.* **2008**, *73*, 7721-7730.

Introduction

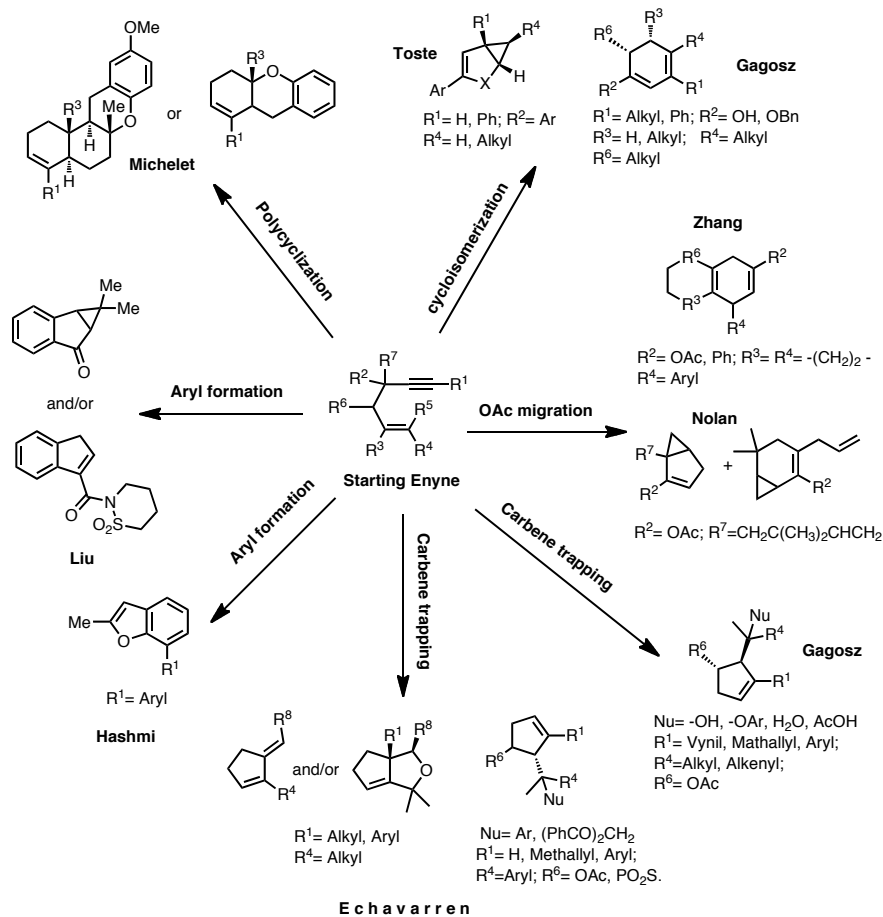

Starting Enyne. $R^1 = \text{H, Alkyl, Aryl, Methallyl}, R^2 = \text{Aryl, OH, OBn, OAc}, R^3 = \text{H, Alkyl, -(CH}_2\text{)}_2\text{-}, R^4 = \text{H, Alkyl, Aryl, -(CH}_2\text{)}_2\text{-}, R^5 = \text{H, Alkyl}, R^6 = \text{H, Alkyl, OAc, PO}_2\text{S}, R^7 = \text{CH}_2\text{C(CH}_3\text{)}_2\text{CHCH}_2$

Scheme I.6.2.1. Selected examples of the reactivity of 1,5-enynes.

The latter reactivity concerning to the carbene-trapping, has been used for the construction of complex organic carbocycles using aldehydes as nucleophiles.^{81,82}

81 Schelwies, M.; Dempwolff, A. L.; Rominger, F.; Helmchen, G. *Angew. Chem.* **2007**, *119*, 5694-5697; *Angew. Chem. Int. Ed.* **2007**, *46*, 5598-5601.

82 Escribano-Cuesta, A.; López-Carrillo, V.; Jansen, D.; Echavarren, A. M. *Chem. Eur. J.* **2009**, *15*, 5646-5650.

Additionally, 1,5-enynes have been used as starting materials in the synthesis of benzo[*b*]furans,⁸³ indenenes and cyclopentanones⁸⁴ or used for mimicking polyolefin carbocyclizations (scheme I.6.2.1).⁸⁵

I.6.2.2. Cyclization of 1,6-Enynes.

Extensive studies on gold(I)-catalyzed 1,6-enyne cycloisomerization have been described.⁸⁶ The main characteristics in this reaction are both the wide diversity as well as the ready build up of molecular complexity. The most representative chemical transformation of 1,6-enynes is the cycloisomerization reaction.^{87,88,89} This reaction has been used in cascade cyclizations involving [3,3]-sigmatropic rearrangements⁹⁰ or [4+2]-cycloaddition ring formation.⁴²

If the cyclization takes place in presence of nucleophiles like amines,⁹¹ alcohols, water,^{35b} or electron-rich aryls,⁹² the addition products are formed.

In the particular case in which the gold(I) carbene is trapped by an olefin, the corresponding cyclopropanes are formed.⁹³ In the absence of nucleophile and

83 Hashmi, A. S. K.; Yang, W.; Rominger, F. *Angew. Chem. Int. Ed.* **2011**, *50*, 5762–5765.

84 Vasu, D.; Hung, H. H.; Bhunia, S.; Gawade, S. A.; Das, A.; Liu, R. S. *Angew. Chem. Int. Ed.* **2011**, *50*, 1–5.

85 Toullec, P. V.; Blarre, T.; Michelet, V. *Org. Lett.* **2009**, *11*, 2888–2891.

86 Pérez-Galán, P.; Martín, N. J. A.; Campaña, A. G.; Cárdenas, D. J.; Echavarren, A. M. *Chem. Asian J.* **2011**, *6*, 482–486.

87 Chao, C. M.; Beltrami, D.; Toullec, P. Y.; Michelet, V. *Chem. Commun.* **2009**, 6988–6990.

88 Lee, S. I.; Kim, S. M.; Kim, S. Y.; Chung, Y. K. *Synlett* **2006**, *14*, 2256–2260.

89 Lee, Y. T.; Kang, Y. K.; Chung, Y. K. *J. Org. Chem.* **2009**, *74*, 7922–7934.

90 Bae, H. J.; Baskar, B.; An, S. E.; Cheong, J. Y.; Thangadurai, D. T.; Hwang, I. C.; Rhee, Y. H. *Angew. Chem. Int. Ed.* **2008**, *47*, 2263–2266

91 Leseurre, L.; Toullec, P. V.; Genet, J. P.; Michelet, V. *Org. Lett.* **2007**, *9*, 4049–4052.

92 Amjis, C. H. M.; Ferrer, C.; Echavarren, A. M. *Chem. Commun.* **2007**, 698–700.

93 Pérez-Galán, P.; Herrero-Gómez, E.; Hog, D. T.; Martín, N. J. A.; Maseras, F.; Echavarren, A. M. *Chem. Sci.* **2011**, *2*, 141–149.

depending on the starting material, allene formation⁹⁴ or skeletal rearrangement⁹⁰ take place.

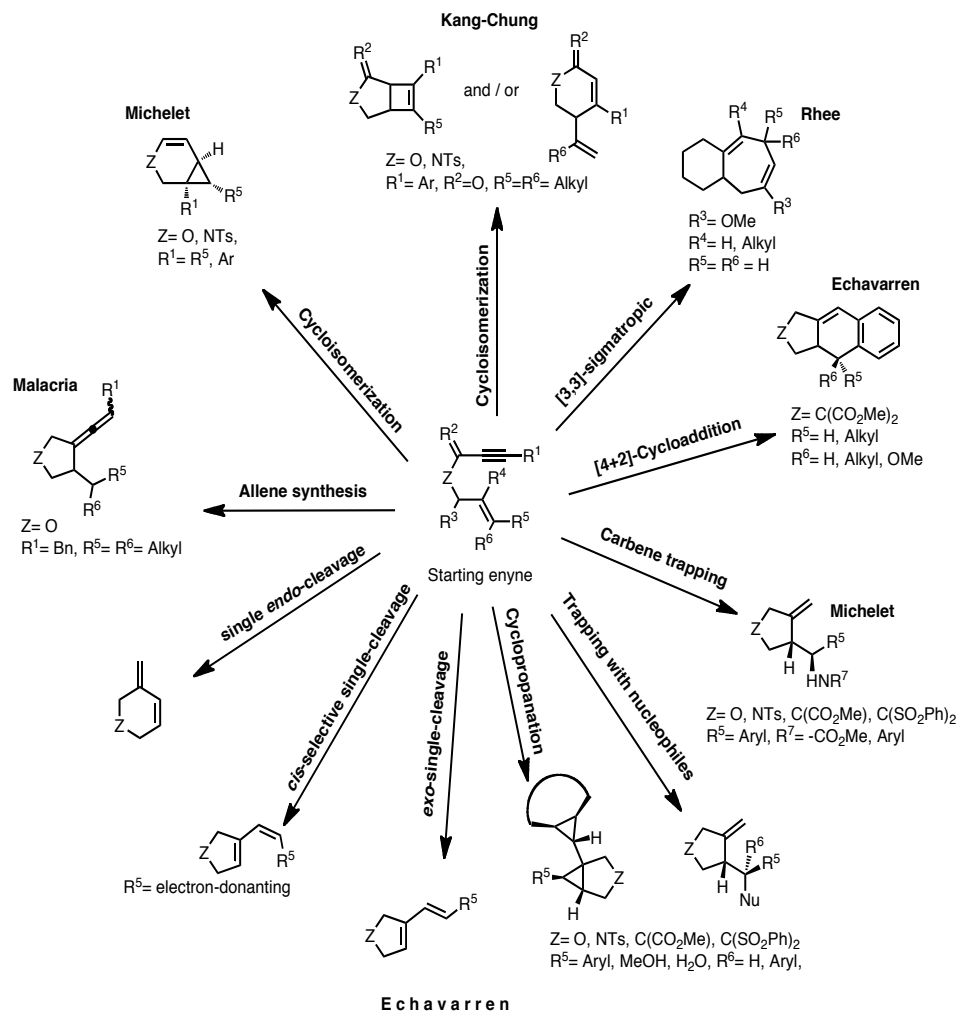

Scheme I.6.2.2. Selected examples of the reactivity of 1,6-enynes.

94 Harrak, Y.; Simonneau, A.; Malacria, M.; Gandon, V.; Fensterbank, L. *Chem. Commun.* **2010**, 46, 865-867.

I.6.2.2.1. Skeletal Rearrangement of 1,6-Enynes.

The regio- and stereochemistry in gold-catalyzed skeletal rearrangement of 1,6-enynes is highly dependent of two main factors: 1) starting material substitution and 2) ligand in catalyst. Thus, (*E*)⁹⁵ or (*Z*)-selective⁹⁶ rearrangements have been reported. Mechanistic studies show that a 6-*endo-dig* or 5-*exo-dig* pathways are involved leading to a single *endo*- or single *exo*-cleavage or double-cleavage products (scheme I.6.2.2.1).⁹⁷

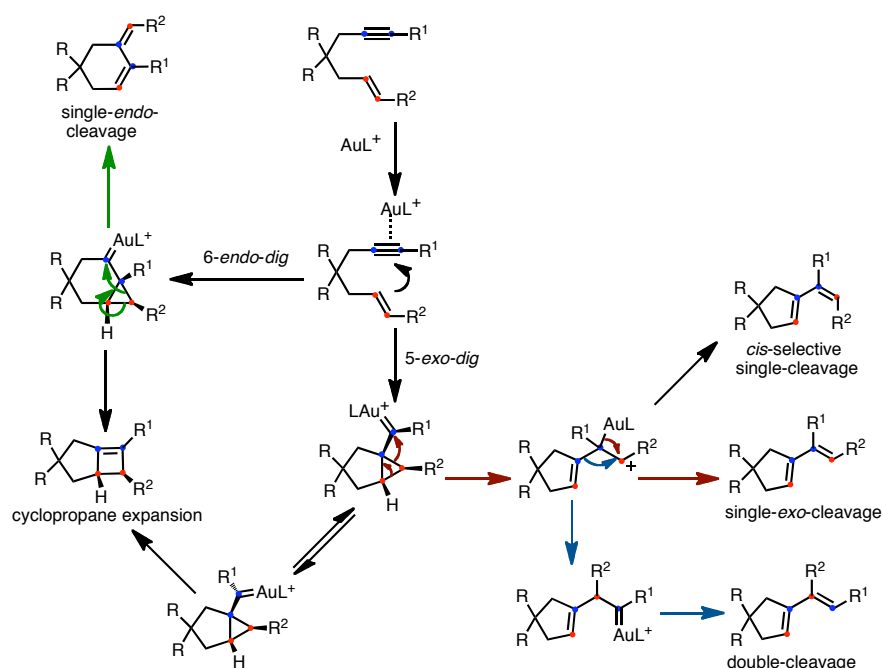

Scheme I.6.2.2.1. Skeletal rearrangement of 1,6-enynes catalyzed by gold(I).

95 Nieto-Oberhuber, C.; López, S.; Muñoz, M. P.; Cárdenas, D. J.; Buñuel, E.; Nevado, C.; Echavarren, A. M. *Angew. Chem. Int. Ed.* **2005**, *44*, 6146–6148.

96 Jiménez-Núñez-E.; Claviere, C. K.; Bour, C.; Cárdenas, D. J.; Echavarren, A. M. *Angew. Chem. Int. Ed.* **2008**, *47*, 7892–7895.

97 Cabello, N.; Jiménez-Núñez, E.; Buñuel, E.; Cárdenas, D. J.; Echavarren, A. M. *Eur. J. Org. Chem.* **2007**, 4217–4223.

1,6-enynes without substitution at the terminal alkyne position and with an alkyl group or hydrogen in the olefin generally will follow *5-exo-dig* pathway to give mainly single-*exo* cleavage products. For the case in which an electron-donating group is attached to the olefin, *cis*-selective single-cleavage products are observed.⁹⁷ On the other hand, single-endo cleavage is favored for enynes in which the tether carbon contains -SO₂Ph.⁹³ Additionally, double-cleavage rearrangement is found with substrates bearing alkyl at the alkene (scheme I.6.2.2.1).

I.6.2.3. Carbene or Carbocationic Character of the Intermediates in Gold Catalysis.

Recently carbenic or carbocationic character of certain intermediates in gold(I)-catalyzed reactions has been topic of study (figure I.6.2.3.1).^{86,98}

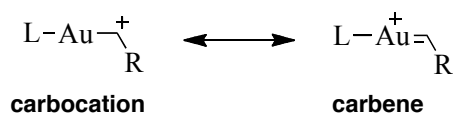

Figure I.6.2.3.1. Resonant forms of carbocation and carbene.

The work of Fürstner is in agreement with the proposal of carbocationic nature of the intermediates.⁹⁹ This conclusion was based on the rotational energy barrier of the allylic carbocations substituted by AuL. A low rotational energy (11.0 Kcal·mol⁻¹) was observed in the key intermediates, generated by a cyclopropene ring opening.

98 Seidel, G.; Mynott, R.; Fürstner, A. *Angew. Chem. Int. Ed.* **2009**, *48*, 2510–2513.

99 Fürstner, A.; Morency, L. *Angew. Chem. Int. Ed.* **2008**, *47*, 5030–5033.

It was demonstrated by NMR spectroscopy that the carbenic contribution in this experiment is low or totally neglectable, and is best defined as a carbocation (scheme I.6.2.3.1).⁹⁹

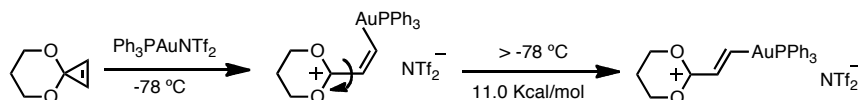

Scheme I.6.2.3.1. Carbocationic character of intermediate in gold catalysis.

The groups of Toste and Goddard determined computational- and experimentally the rotational barrier around the systems with groups less electron-donating comparing with those studied by Fürstner.³¹ Interestingly, it was found that by replacing the oxygen for carbon atoms, very different values were observed. A barrier of 22.5 Kcal/mol was found, which shows that AuPPh₃ has an stabilizing effect on the carbocation similar to a OMe group (23.3 Kcal/mol) (figure I.6.2.3.2).

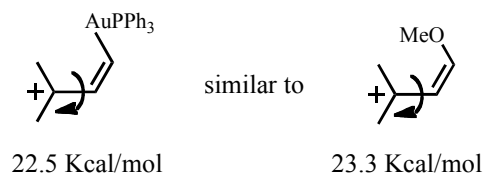
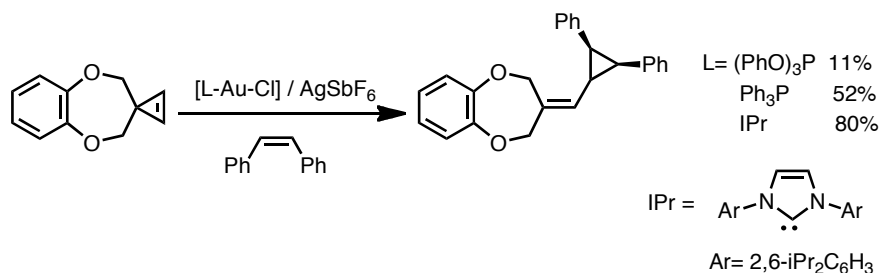

Figure I.6.2.3.2. Rotational barrier for an allylic gold carbene and comparison with enolether analog.

Additionally, it was demonstrated that the cyclopropanation reaction of this sort of substrates is possible, confirming the carbene character. Various ligands were tested and it was found that NHC carbene led to optimum reaction yields. (scheme I.6.2.3.3).



Scheme I.6.2.3.3. Carbenic character of intermediate gold-catalyzed cyclopropanation.

These results indicate that the carbene character of the cationic intermediates is enhanced by using Au(I) catalysts with highly donating NHC ligands, whereas intermediates with phosphite ligands possess a more carbocationic character.

I.6.3. Other Relevant Reactions Catalyzed by Gold(I)-Complexes

Various gold-catalyzed reactions have been developed mainly since 1997 when the reactivity of gold took its starting importance. Some of them have been commented in this chapter, however it is worth mentioning few additional described reactions (A-M). Gold-catalyzed cyclopropanations will be discussed in chapter III.

Gold(I)-catalyzed Conia-ene reactions take place by addition of β -keto esters to alkynes (Scheme 1.6.3.1 A).¹⁰⁰ Addition reactions of strong Lewis bases such as secondary amines to alkynes promoted by gold complexes bearing a P,N-ligand have been also described (Scheme 1.6.3.1 B).¹⁰¹

¹⁰⁰ Kennedy-Smith, J. J.; Staben, S. T.; Toste, F. D. *J. Am. Chem. Soc.* **2004**, *126*, 4526-4527.

¹⁰¹ Hesp, K. D.; Stradiotto, M. *J. Am. Chem. Soc.* **2010**, *132*, 18026-18029.

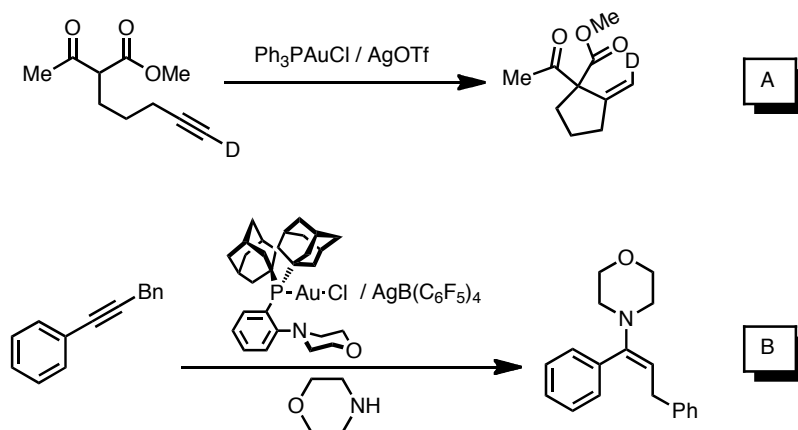

Scheme I.6.3.1. Gold(I)-catalyzed Conia-ene and addition of amines to alkynes.

Ring expansion reaction of alkynylcyclopropanols leads to the formation of cyclobutanones (shceme I.6.3.2 C).¹⁰² The enantioselective version of this reaction using allenes was also developed (shceme I.6.3.2 D).¹⁰³

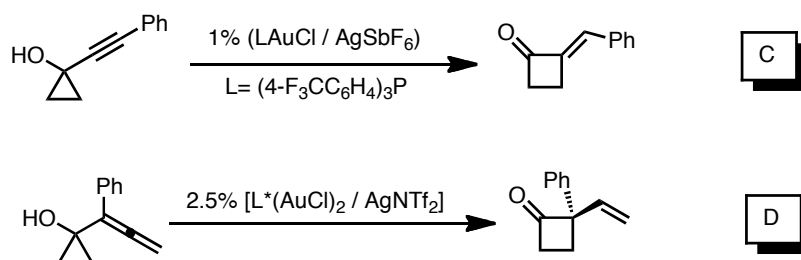

Scheme I.6.3.2. Gold(I)-catalyzed ring expansion and enantioselective version.

One of the most innovative applications in enantioselective catalysis in the field is the asymmetric induction by the chiral counteranion. This concept was developed for hydroamination as well as hydroalkoxylation of allenes (shceme I.6.3.2 E).¹⁰⁴

¹⁰² Markham, J. P.; Staben, S. T.; Toste, F. D. *J. Am. Chem. Soc.* **2005**, *127*, 9708-9709.

¹⁰³ Kleinbeck, F.; Toste, F. D. *J. Am. Chem. Soc.* **2009**, *131*, 9178-9179.

¹⁰⁴ Hamilton, G. L.; Kang, E. J.; Mba, M.; Toste, F. D. *Science* **2007**, *317*, 496-499.

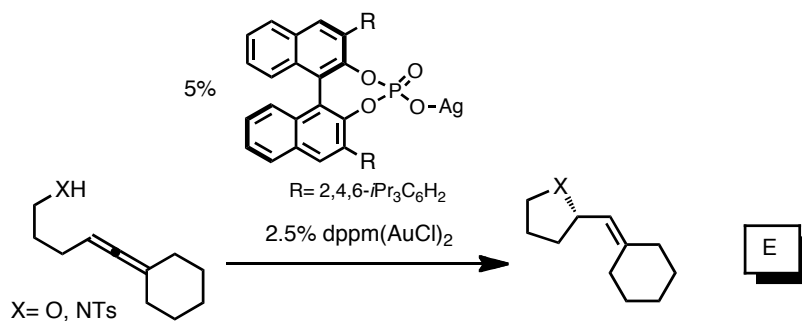

Scheme I.6.3.3. Gold(I)-catalyzed counteranion-induced asymmetric hydroamination and hydroalkoxylation of allenes.

Intra- and intermolecular oxidation of alkynes in gold catalysis has been reported, using sulfoxide-based oxidants (scheme I.6.3.4 F and G)^{58a,105} or quinoline *N*-oxides (scheme I.6.3.4 H).¹⁰⁶

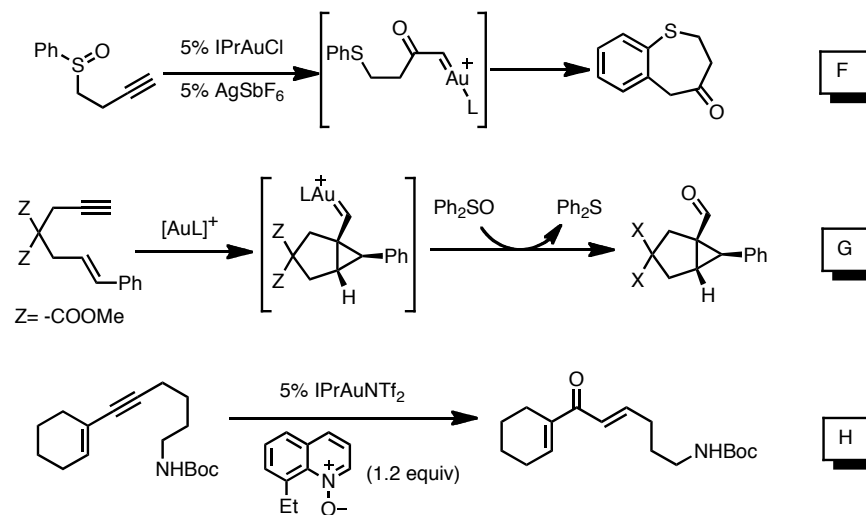

Scheme I.6.3.4. Gold(I)-catalyzed oxidative reactions.

105 Witham, C. A.; Mauleon, P.; Shapiro, N. D.; Sherry, B. D.; Toste, F. D. *J. Am. Chem. Soc.* **2007**, *129*, 5838-5839.

106 Lu, B.; Li, C.; Zhang, L. *J. Am. Chem. Soc.* **2010**, *132*, 14070-14072.

The oxidative oxyarylation and aminoarylation of alkenes has also been developed (scheme I.6.3.5 I and J).^{107,108}

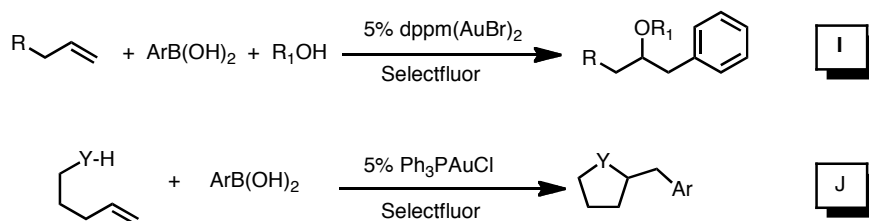

Scheme I.6.3.5. Gold(I)-Gold(III)-catalyzed oxidative oxyarylation and aminoarylation of alkenes.

The use of indole as nucleophile in intermolecular additions to alkynes allows building complex carbon skeleton under catalytic conditions (scheme I.6.3.7 K and L).^{109,110}

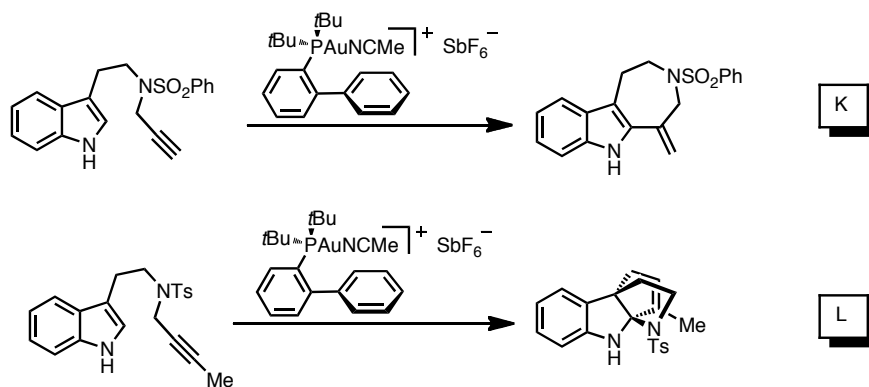

Scheme I.6.3.7. Gold(I)-catalyzed intramolecular reaction of indoles with alkynes.

107 Melhado, A. D.; Brenzovitch, W. E.; Lackner, A. D; Toste, F. D. *J. Am. Chem. Soc.* **2010**, *132*, 8885-8887

108 Zhang, G.; Cui, L.; Wang, Y.; Zhang, L. *J. Am. Chem. Soc.* **2010**, *132*, 1474-1475.

109 Ferrer, C.; Echavren, A. M. *Angew. Chem. Int. Ed.* **2006**, *45*, 1105-1109.

110 Ferrer, C.; Amjis, C. H. M.; Echavarren, A. M. *Chem. Eur. J.* **2007**, *13*, 1358-1373.

Recently the parent reaction between alkynes and alkenes catalyzed by gold(I) has been developed in our group as a procedure for the synthesis of cyclobutenes (scheme I.6.3.9 M).¹¹¹

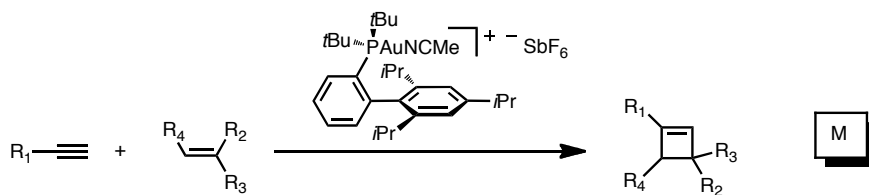

Scheme I.6.3.9. Gold(I)-catalyzed intermolecular [2+2] cycloaddition of alkynes with alkenes.

¹¹¹ López-Carrillo, V.; Echavarren, A. M. *J. Am. Chem. Soc.* **2010**, *13*, 9292-9294.

I.7. C₆₀, The Discovery and Genesis.

In 1985, intrigued by the genesis of long-chain carbon molecules formed in the interstellar space, and circumstellar shells,¹¹² Kroto suggested to their colleagues Smalley and Curl both at Rice University to carry out laser spectroscopy experiments to study this phenomena. By graphite vaporization using laser irradiation in the experiments they discovered a very stable cluster formed by 60 carbon atoms, they proposed structures of truncated icosahedron of 60 vertices and 32 faces, 12 of which are pentagonal and 20 hexagonal. Because of its symmetry, this molecule could be formally be opened preserving its twelve pentagons to form an C₆₀ derivative consisting in four trindanes, each containing three pentagons.

The vaporization of carbon was studied prior to the work of Kroto, Smalley and Curl.¹¹³ However clusters of more than 190 carbons atoms were observed and analyzed by mass spectroscopy. In these experiments the C₆₀ peak was present but was no the predominant one. However they demonstrated that this peak could be increased in more than 40 times in reference with the neighbouring clusters under certain conditions. This molecule was called buckminsterfullerene¹¹⁴ or simply fullerene C₆₀ regarding to the architect Buckminster Fuller.

I.7.1. Chemical Interest to Synthesize Fullerenes.

Architecturally C₆₀ has a unique and non-usual curved geometry based on trigonal carbon atoms, C₆₀ possesses relevant electronic properties and due to its poliaromatic nature, various properties have been found.¹¹⁵

112 Kroto, H. W.; Heath, J. R.; O'Brien, S. C.; Curl, R. F.; Smalley, R. E. *Astrophys. J.* **1987**, *314*, 352-355.

113 Rohlffing, E. A.; Cox, D. M.; Kalador, A. J. *J. Chem. Phys.* **1984**, *81*, 3322-3330.

114 Kroto, H. W.; Heath, J. R.; O'Brien, S. C.; Curl, R. F.; Smalley, R. E. *Nature*, **1985**, *318*, 162-163.

115 Arena, F.; Bullo, F.; Conti, F.; Corvaja, C.; Maggini, F.; Prato, M.; Scorrano, G. *J. Am. Chem.*

At present, the synthesis of C₆₀ takes place in ton-scale by combustion at relative low cost (*e.g.* 200 dls/Kg), starting from simple and affordable hydrocarbons.¹¹⁶

A molecular orbital analysis among C₆₀ and superior fullerenes reveal that these molecules are characterized by low laying LUMOs and higher laying HOMOs for the superior fullerenes.¹¹⁷ Higher fullerenes are less strained than C₆₀, and hence thermodynamically more stable.

In reference to higher fullerenes (> C₆₀ *e.g.* C₆₆, C₆₈, C₇₀, C₇₆, C₇₈, C₈₄ or C₁₀₀), it is possible to predict the formation and isolation of these fullerenes and their isomers that obey the Isolated Pentagon Rule (IPR). This rule was proposed in 1987 by Kroto according to the observation that the local strain increases with the number of bonds shared by two pentagons, thus affording a less stable molecule. Then IPR establish that “all pentagons must be surrounded by hexagons” forming a corannulene moiety. In agreement with this, fullerenes use to be called IPR- or no IPR-fullerenes.¹¹⁵

However some non-IPR fullerenes have been described.¹¹⁸ The IPR is universal for all the fullerenes however, was independently reported by Xie¹¹⁹ and Jansen¹²⁰ an exception to the rule for the cluster C₇₂Cl₄.

Soc. **1997**, *119*, 789-795.

116 J. B. Howard, D. F. Kronholm, A. J. Modestino, H. Richter, (Nano-C, USA), US-A 2003021018, 2003. See also www.nano-c.com.

117 P. W. Fowler, D. E. Manolopoulos, *Atlas of Fullerenes*, Oxford University, Oxford, 1995.

118 a) Wakahara, T.; Nikawa, H.; Kikuchi, T.; Nakahodo, T.; Rahman, G. M. A.; Tsuchiya, T.; Maeda, T.; Akasaka, T.; Yoza, K.; Horn, E.; Yamamoto, K.; Mizorogi, N.; Slanina, Z.; Nagase, S. *J. Am. Chem. Soc.* **2006**, *128*, 14228-14229 ; b) Lu, X.; Nikawa, H.; Nakahodo, T.; Tsuchiya, T.; Ishitsuka, M.O.; Maeda, T.; Akasaka, T.; Toki, M.; Sawa, H.; Slanina, Z.; Mizorogi, N.; Nagase, S. *J. Am. Chem. Soc.* **2008**, *130*, 9129-9136 ; c) Lu, X.; Nikawa, H.; Tsuchiya, T.; Maeda, T.; Ishitsuka, M. O.; Akasaka, T.; Toki, M.; Sawa, H.; Slanina, Z.; Mizorogi, N.; Nagase. *Angew. Chem. Int. Ed.* **2008**, *47*, 8642-8645.

119 Tan, Y-Z.; Zhou, T.; Bao, J.; Shan, G.-J.; Xie, S. Y.; Huang, R. B.; Zheng, L. S. *J. Am. Chem. Soc.* **2010**, *132*, 17102-17104.

120 Ziegler, K.; Mueller, A.; Amsharov, K. Y.; Jansen, M. *J. Am. Chem. Soc.* **2010**, *132*, 17099-17101.

I.7.2. Synthesis of C₆₀.

I.7.2.1. Synthesis of C₆₀ Fragments

Flash vacuum pyrolysis (FVP) has been exhaustively exploited in the synthesis of planar as well as geodesic fullerene fragments. Such fragments are ranging from the small C₂₀H₁₀ corannulene to C₆₀H₃₀ or C₆₀H₂₇Cl₃ and finally C₆₀.¹²¹

C₂₀H₁₀ corannulene has been synthesized by FVP starting from different precursors (scheme I.7.2.1.1).^{122,123}

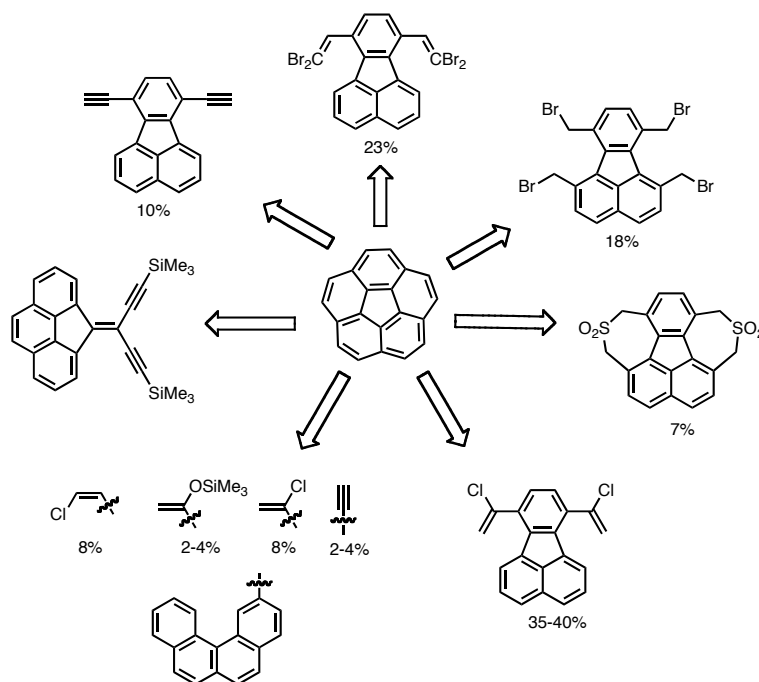

Scheme I.7.2.1.1. Representative retro-synthesis of corannulene by FVP.

121 a) Tsefrikas V. M.; Soctt, L. T. *Chem. Rev.* **2006**, *106*, 4868-4884. b) Scott, L. T. *Angew. Chem. Int. Ed. Ing.* **2004**, *43*, 4949-5007.

122 Scott, L. T.; Hashemi, M. M.; Bratcher, M. S. *J. Am. Chem. Soc.* **1992**, *114*, 1920.

123 Borchardt, A.; Fuchicello, A.; Kilway, K. V.; Baldrige, K. K.; Siegel, J. S. *J. Am. Chem. Soc.* **1992**, *114*, 1921.

$C_{22}H_{10}$ Acecorannulene was synthesized by FVP using similar precursors (scheme I.7.2.1.2).^{124,125}

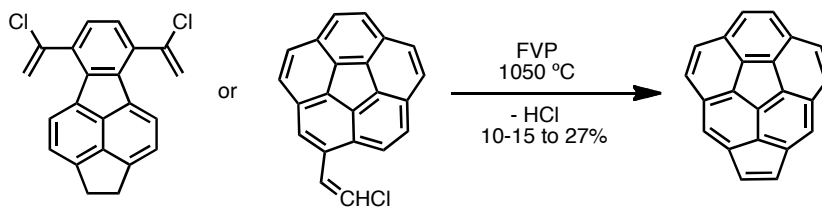

Scheme I.7.2.1.2. Synthesis of acecorannulene by FVP.

By using similar substituted starting materials, it was possible the synthesis of $C_{24}H_{12}$ benzo[*a*]corannulene (scheme I.7.2.1 A).¹²⁶

Several C_{26} - C_{42} polyarenes has also been synthesized: $C_{26}H_{12}$ tetrabenzopyracylene (scheme I.7.2.1 B),¹²⁷ $C_{26}H_{12}$ fluoranthenes (scheme I.7.2.1 C),¹²⁸ $C_{26}H_{12}$ indeno[1,2,3-*bc*]corannulene (scheme I.7.2.1 D),¹²⁹ $C_{26}H_{12}$ benzo[*g*]acecorannulene (scheme I.7.2.1 E),¹³⁰ $C_{28}H_{12}$ fluoreno[1,9,8-*abcd*]corannulene (scheme I.7.2.1 F),¹³¹ $C_{28}H_{12}$ acenaphto[1,2,3-*bcd*]corannulene (scheme I.7.2.1 G),¹³² $C_{30}H_{12}$ [5,5] circulene (scheme I.7.2.1 H),¹³³ $C_{30}H_{12}$ hemifullerene or trindene triphenylene (scheme I.7.2.1 I),¹³⁴ $C_{30}H_{14}$

124 Abdourazak, A. H.; Sygula, A.; Rabideau, P. W. *J. Am. Chem. Soc.* **1993**, *115*, 3010.

125 Sygula, A.; Abdourazak, A. H.; Rabideau, P. W. *J. Am. Chem. Soc.* **1996**, *118*, 339.

126 Mehta, G.; Srirama Sarma, P. V. V. *Chem. Commun.* **2000**, 19.

127 Scott, L. T. *Pure Appl. Chem.* **1996**, *68*, 291.

128 Scott, L. T.; Preda, D. V. In *Abstracts of Papers, 219th National Meeting of the American Chemical Society*, San Francisco, CA, March 2000; American Chemical Society: Washington, DC, 2000; abstr ORGN-516.

129 Rai, A. K. M.S. Thesis, Boston College, Chestnut Hill, MA, 1996.2006.

130 Tsefrikas, V. M.; Arns, S.; Merner, P. M.; Warford, C. C.; Merner, B. L.; Scott, L. T.; Bodwell, G. J. *Org. Lett.* **2006**, *8*, 5195-5198.

131 Hagen, S.; Christoph, H.; Zimmerman, G. *Tetrahedron* **1995**, *51*, 6961.

132 Scott, L. T.; Roelofs, N. H. *J. Am. Chem. Soc.* **1987**, *109*, 5461.

133 Rabideau, P. W.; Abdourazak, A. H.; Folsom, H. E.; Marcinow, Z.; Sygula, A.; Sygula, R. *J. Am. Chem. Soc.* **1994**, *116*, 7891.

134 Abdourazak, A. H.; Marcinow, Z.; Sygula, A.; Sygula, R.; Rabideau, P. W. *J. Am. Chem. Soc.* **1995**, *117*, 6410-6411.

dibenzo[*f,l*]acecorannulene (scheme I.7.2.1 J),¹³⁵ C₃₀H₁₄ acenaphtho[3,2,1,8-*efghi*]peropyrene (scheme I.7.2.1 K),¹³⁶ C₃₂H₁₆ tribenzo[*adj*]corannulene (scheme I.7.2.1 L),¹²⁶ C₃₄H₁₆ dibenz[*a,j*]indeno[*ef*]corannulene (scheme I.7.2.1 M),¹³⁷ C₃₆H₁₂ circumtrindene (scheme I.7.2.1 N),¹³⁸ C₄₀H₁₄ Diphenanthro[1,10,9,8-*abcde:1'10'9'8'-jklmn*] tetracyclopentapyrene (scheme I.7.2.1 O),¹³⁹ C₄₂H₁₄ indeno[1,2,3-*bc*]circumtrindene (scheme I.7.2.1 P)¹⁴⁰ and C₆₀ (scheme I.7.2.1).

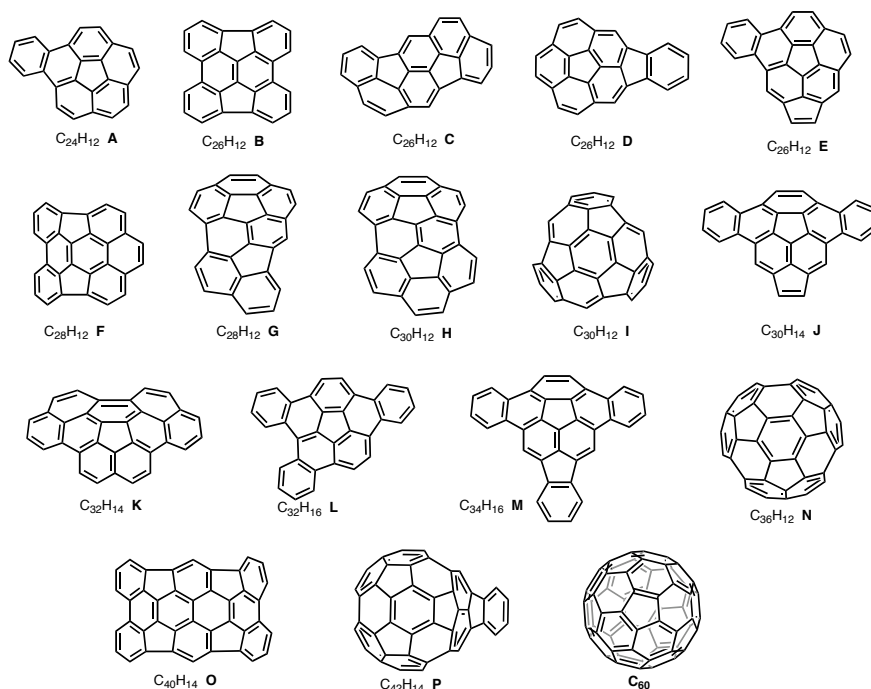

Scheme I.7.2.1.3. Representative geodesic polyarenes synthesized by FVP.

135 Weitz, A.; Shabtai, E.; Rabinovitz, M.; Bratcher, M. S.; McComas, C. C.; Best, M. D.; Scott, L. T.

Chem. Eur. J. **1998**, *4*, 234-238.

136 Ansems, R. B. M.; Scott, L. T. Unpublished results.

137 Imamura, K.; Takimiya, K.; Otsubo, T.; Aso, Y. *Chem. Commun.* **1999**, 1859-1862.

138 Scott, L. T.; Bratcher, M. S.; Hagen, S. *J. Am. Chem. Soc.* **1996**, *118*, 8743-8744.

139 Peng, L. Ph.D. Dissertation, Boston College, Chestnut Hill, MA, 2006.

140 Ansems, R. B. M. Ph.D. Dissertation, Boston College, Chestnut Hill, MA, 2004.

I.7.2.2. Synthesis of C₆₀ Fragments by Palladium-Catalyzed arylation and Cross-Coupling.

Cross-Coupling.

Concerning to the synthesis of C₆₀ fragments by arylation or cross-coupling, one of the most relevant starting materials is truxene. This white solid has C₃ symmetry and is a fragment of fullerene. The benzylic functionalization to get mixtures of alkylated *syn* and *anti* derivatives has been described. The *anti* isomer can be cleanly converted to the *syn* stereoisomer by treatment with base (scheme I.7.2.2.1).¹⁴¹

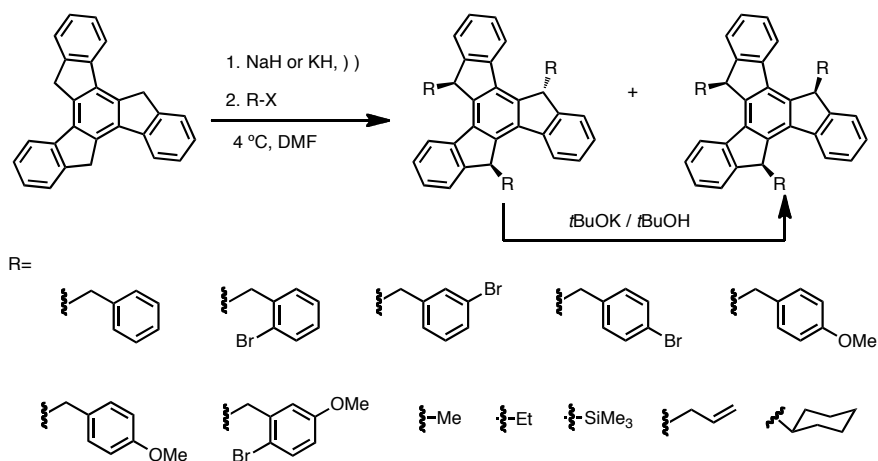

Scheme I.7.2.2.1. Selective *syn* alkylation of truxene.

Some of the benzyl-truxene derivatives self-associate strongly in solution by arene stacking.^{141,142} Functionalization of truxene can be carried out through truxenetrione to form new C_{3h} and C_{3v} derivatives (scheme I.7.2.2.2).¹⁴³

¹⁴¹ de Frutos, O.; Granier, T.; Gómez-Lor, B.; Jiménez-Barbero, J.; Monge, M. A.; Gutiérrez-Puebla, E.; Echavarren, A. M. *Eur. J. Org. Chem.* **2002**, 2879-2890.

¹⁴² de Frutos, O.; Gómez-Lor, B.; Granier, T.; Monge, M. A.; Gutiérrez-Puebla, E.; Echavarren, A. M. *Angew. Chem. Int. Ed.* **1999**, *38*, 204-207.

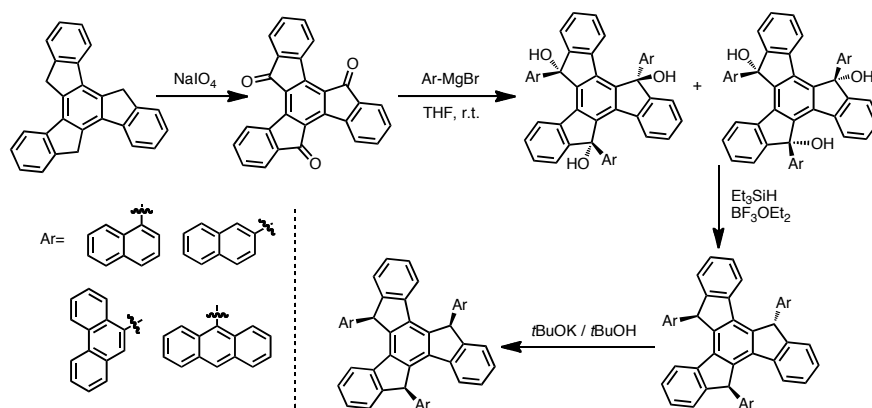

Scheme I.7.2.2.2. Synthesis of *syn* aryltruxenes.

Bromination followed by palladium-catalyzed cross-coupling lead to trisubstituted derivatives (scheme I.7.2.2.3).^{144, 145}

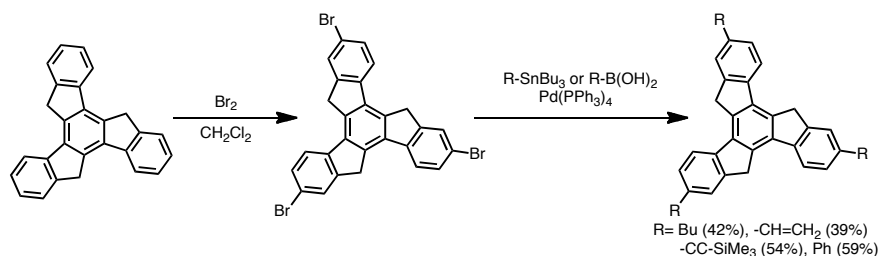

Scheme I.7.2.2.3. Palladium-catalyzed functionalization of truxene by cross-coupling.

Here a sequence that involves truxene alkylation and palladium-catalyzed arylation with the formation of three C-C bonds led to the synthesis of a C₆₀H₃₀

143 Ruiz, M.; Gómez-Lor, B.; Santos, A.; Echavarren, A. M. *Eur. J. Org. Chem.* **2004**, 858-866.

144 Gómez-Lor, B.; de Frutos, O.; Ceballos, P. A.; Granier, T.; E.; Echavarren, A. M. *Eur. J. Org. Chem.* **2001**, 2107-2114.

145 Gómez-Lor, B.; González-Cantalapiedra, E.; Ruiz, M.; de Frutos O.; Cárdenas, D. J.; Santos, A.; Echavarren, A. M. *Chem. Eur. J.* **2004**, *10*, 2601-2608.

molecule, which represent an open C₆₀ and was named crushed fullerene. A couple of derivatives were also synthesized (scheme I.7.2.2.4).¹⁴⁶

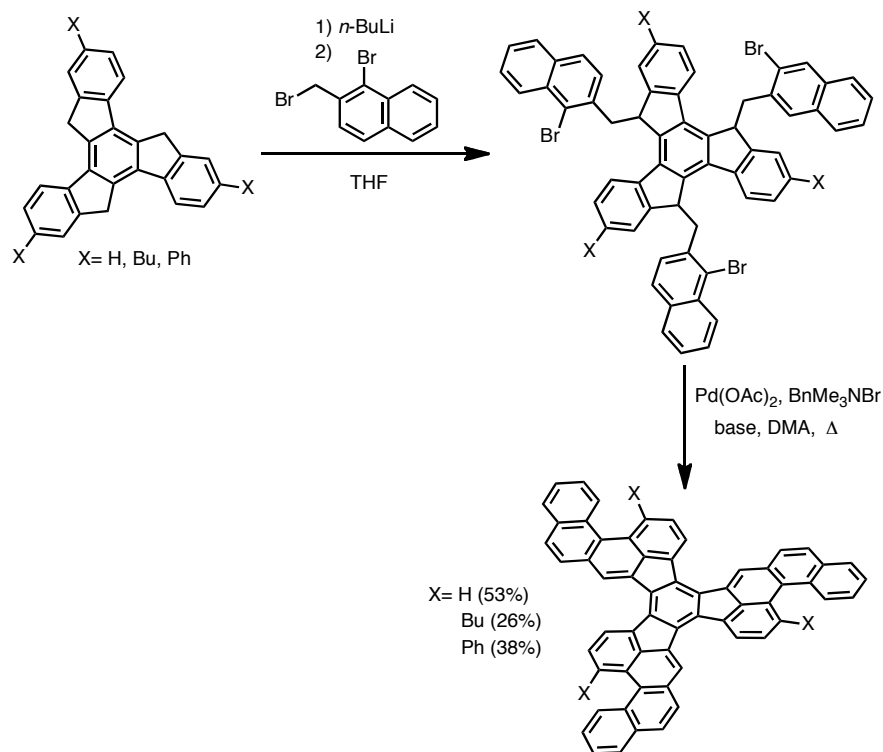

Scheme I.7.3.2.4. Synthesis of a crushed fullerene and analogs.

The synthesis of the triaza analogue of crushed fullerene was carried out by an intramolecular palladium catalyzed arylation reaction as the final step (scheme I.7.3.2.5).¹⁴⁷

¹⁴⁶ Gómez-Lor, B.; de Frutos, O.; Echavarren, A. M. *Chem. Commun.* **1999**, 2431-2432.

¹⁴⁷ Gómez-Lor, B.; Echavarren, A. M. *Org. Lett.* **2004**, *6*, 2993-2996.

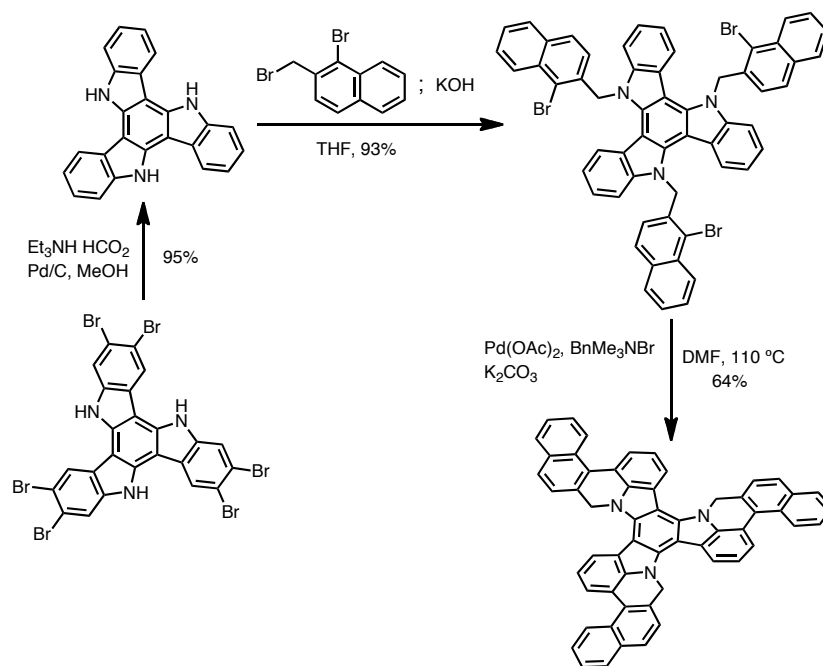

Scheme I.7.2.2.5. Synthesis of crushed triaza-fullerene.

An interesting methodology involving Suzuki-Heck sequence to build up acenaphthene derivatives was described by Scott and co-workers.¹⁴⁸ Functionalized acenaphthenes were synthesized by means of a one pot reaction protocol (scheme I.7.3.2.6).

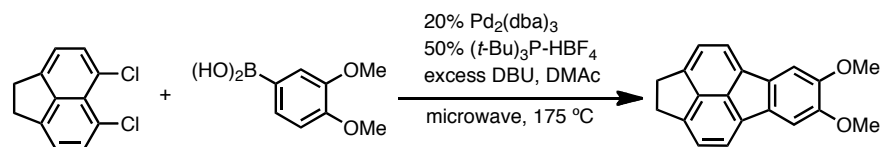

Scheme I.7.2.2.6. Synthesis of acenaphthene derivatives by Suzuki-Heck sequence.

148 Quimby, J. M.; Scott, L. T. *Adv. Synth. Catal.* **2009**, *351*, 1009-1013.

I.7.2.3. Total Synthesis of C₆₀.

In 1998 Rubin¹⁴⁹ and Tobe¹⁵⁰ independently synthesized a highly strained cyclophane which by laser desorption collapsed to C₆₀ under high energy conditions in gas phase. However no synthetic isolable amounts of fullerene were obtained and the product was characterized just by mass spectrometry (scheme 1.7.2.3.1).

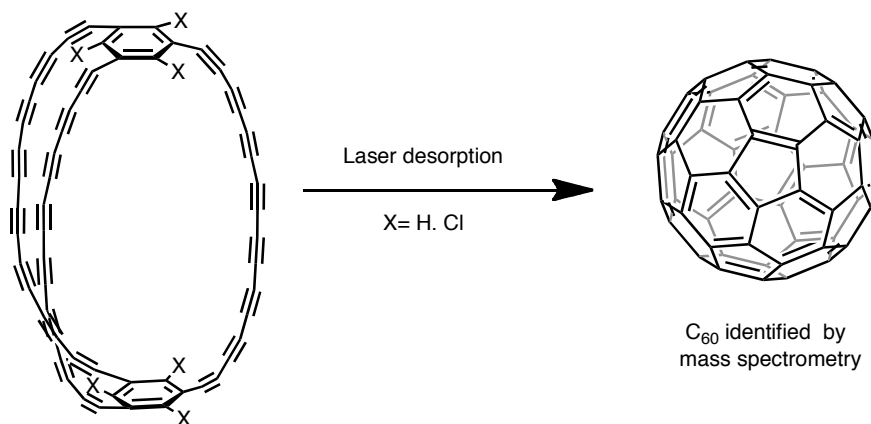

Scheme I.7.2.3.1. Rubín and Tobe synthesis of C₆₀ by laser desorption irradiation.

To date, only three successful total synthesis of fullerene C₆₀ have been described. In all of them, the key step is a final cyclodehydrogenative C-C bond formation. In the first two cases the final step was carried out by FVP (scheme I.7.2.3.2).^{151,152}

149 Rubin, Y.; Parker, T. C.; Pastor, S. J.; Jalisatgi, S.; Boule, C.; Wilkins, C. L. *Angew. Chem. Int. Ed.* **1998**, *37*, 1226-1228.

150 Tobe, Y.; Nakagawa, N.; Naemura, K.; Wakabayashi, T.; Shida, T.; Achiba, Y. *J. Am. Chem. Soc.* **1998**, *120*, 4544-4546.

151 Boorum, M. M.; Vasil'ev, Y. V.; Drewello, T.; Scott, L. T. *Science* **2001**, *94*, 828-831.

152 Scott, L. T.; Boorum, M. M.; McMahon, B. J.; Hagen, S.; Mack, J.; Blank, J.; Wegner, H.; Meijere, A. *Science* **2002**, *295*, 1500-1503.

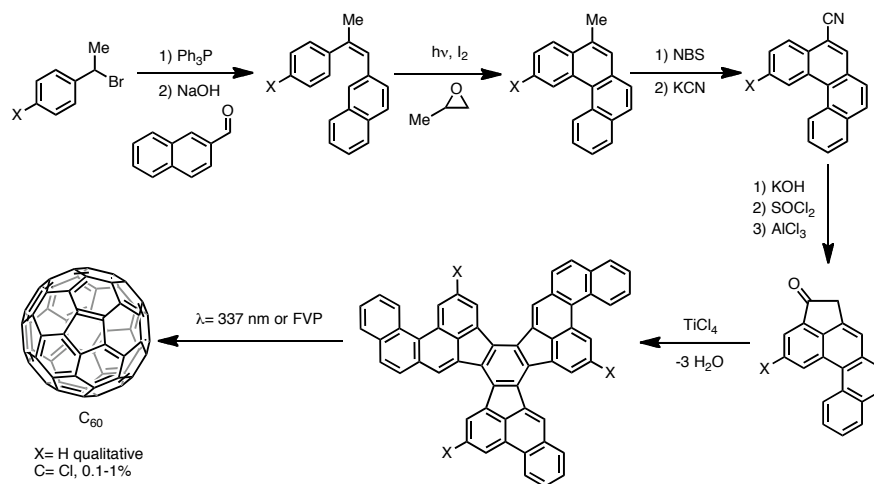

Scheme I.7.2.3.2. Synthesis of C₆₀ by laser irradiation or by FVP.

The last total synthesis of fullerene was performed by the cyclodehydrogenation over a Pt(111) surface heated to 750 K. This procedure was used to synthesized by first time the triaza analog of C₅₇N₃ of fullerene (scheme I.7.3.3.3).

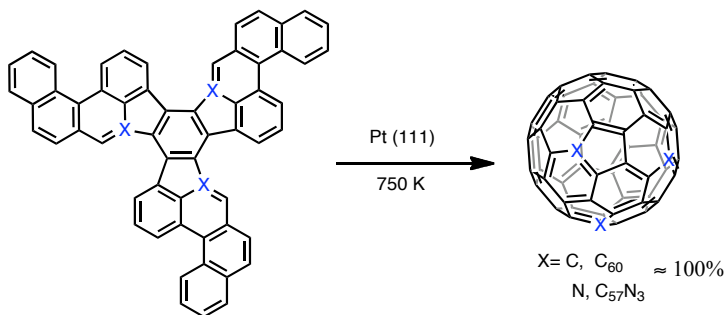

Scheme I.7.2.3.3. Synthesis of fullerene and triaza-fullerene by cyclodehydrogenation over Pt(111) at 750 K.

UNIVERSITAT ROVIRA I VIRGILI
GOLD (I)-CATALYZED RETRO-CYCLOPROPANATION REACTION AND DEVELOPMENT OF TRINDANE-BASED
APPROACH TOWARD C60
Cesar Rogelio Solorio Alvarado
DL: T. 1714-2011

CHAPTER I

Gold(I)-Catalyzed 1,6-Propargylic Migration of Ethers

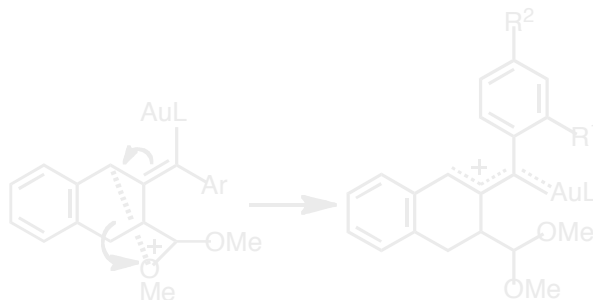

UNIVERSITAT ROVIRA I VIRGILI
GOLD (I)-CATALYZED RETRO-CYCLOPROPANATION REACTION AND DEVELOPMENT OF TRINDANE-BASED
APPROACH TOWARD C60
Cesar Rogelio Solorio Alvarado
DL: T. 1714-2011

CHAPTER I

Introduction

Gold(I)-catalyzed cycloisomerization reactions of enynes has been well documented.^{64a} Mechanistic studies focused on the nature of the substitution pattern of the enynes, revealed substrate-dependent divergence in the reaction pathways. Specifically, cyclization reactions of 1,6-enynes **1** bearing strongly electron-donating groups on the alkene, proceed non-stereospecifically via the open carbocation **2a**, to give selectively the *cis* single-cleavage products **3** (Scheme 1.1).¹⁵³

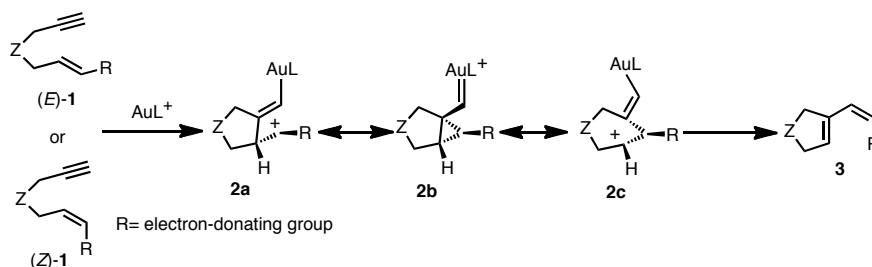

Scheme 1.1. Cycloisomerization of 1,6-enynes yielding *cis* single-cleavage products.

Based on these results, we considered the importance of exploring the reactivity of enynes featuring other substituents at the propargylic position of the enyne.

A new gold-catalyzed cascade reaction involving a formal [2+2+2] cycloaddition of 1,6-enynes bearing propargylic silyl ethers and a carbonyl group in the starting enyne have been studied in our group for the stereoselective synthesis of

153 Cabello, N.; Jiménez-Núñez, E.; Bunuel, E.; Cardenas, D. J.; Echavarren, A. M. *Eur. J. Org. Chem.* **2007**, 25, 4217-4223.

pubinernoid B (Scheme 1.2).¹⁵⁴

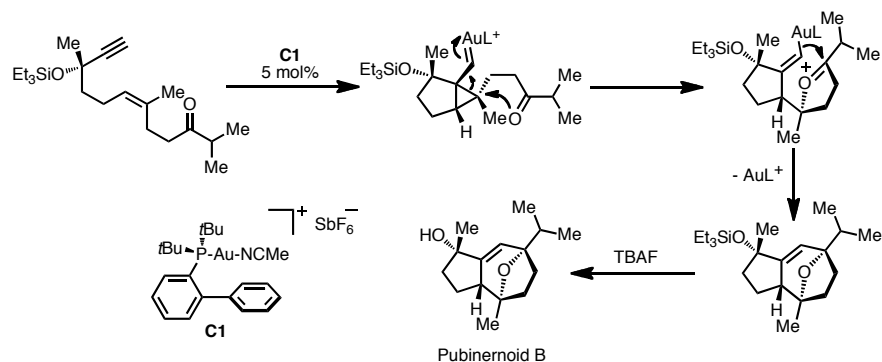

Scheme 1.2. Stereoselective synthesis of pubinernoid B via a [2+2+2] cycloaddition reaction.

The proposed mechanism of this reaction involves an initial *5-exo-dig* cyclization of **4** to form a cyclopropyl gold(I) carbene intermediate **5** (Scheme 1.3). Then cyclopropane opening by the carbonyl group to generate an oxonium cation **6**, with concomitant Prins-trapping from the alkenyl-gold fragment leads to the formation of the tricyclic intermediate **7a**. Elimination of the metal generates *syn*-**8a**. However, epimerization can take place by an equilibrium between **7a**, **7b** and **7c** to form *anti*-**8b**. Additionally **7a** can alternatively open to form ketone **8c**.

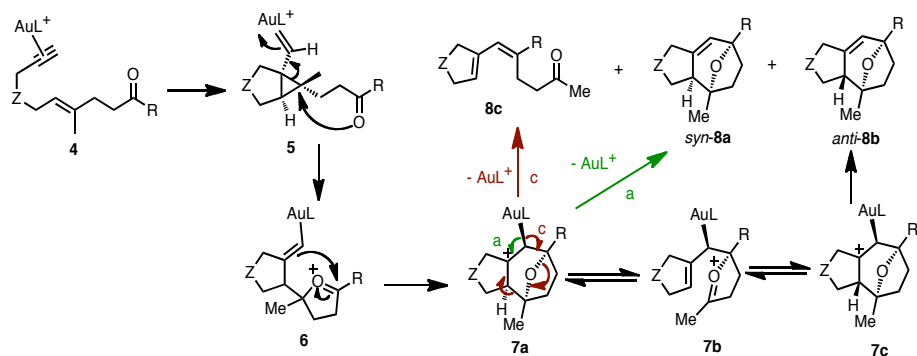

Scheme 1.3. Mechanism in the [2+2+2] cycloisomerization of 1,6-enynes.

154 Jiménez-Núñez, E.; Claverie, C. K.; Nieto-Oberhuber, C.; Echavarren, A. M. *Angew. Chem. Int. Ed.* **2006**, *45*, 5452-5455.

This cyclization cascade was applied for the synthesis of naturally occurring compounds such as orientalol F¹⁵⁵ and englerins A and B (figure 1.1).¹⁵⁶

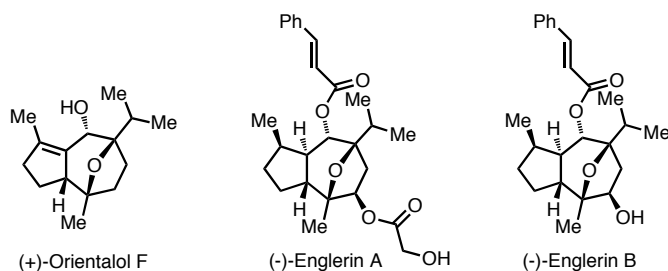
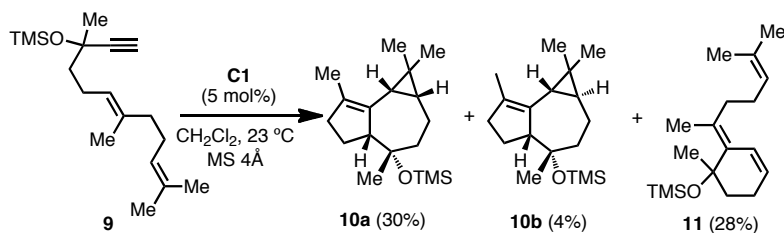

Figure 1.1. Targets synthesized by formal [2+2+2] cycloaddition of oxo-1,6-enynes.

1,6-enynes leading a carbonyl group reacted differently to give products of 1,5-migration of the OR group **10a** and **10b** (Scheme 1.4).



Scheme 1.4. Cycloisomerization of 1,6-enynes lacking a carbonyl group in the starting enyne.

Compounds **10a-b** feature the tricyclic core skeleton related of natural occurring sesquiterpenes such as globulol, epiglobulol¹⁵⁷ and halichonadin F¹⁵⁸ (Figure 1.2).

155 Jiménez-Núñez, E.; Molawi, K.; Echavarran A. M. *Chem. Commun.* **2009**, 7327-7329.

156 Molawi, K.; Delpont, N.; Echavarran A. M. *Angew. Chem. Int. Ed.* **2010**, *49*, 3517-3519.

157 Caine, D. S.; Gupton, T. S. *J. Org. Chem.* **1975**, *40*, 809-810.

158 Ishiyama, H.; Kozawa, S.; Aoyama, K.; Mikami, Y.; Fromont, J.; Kobayashi, J. *J. Nat. Prod.* **2008**, *71*, 1301-1303.

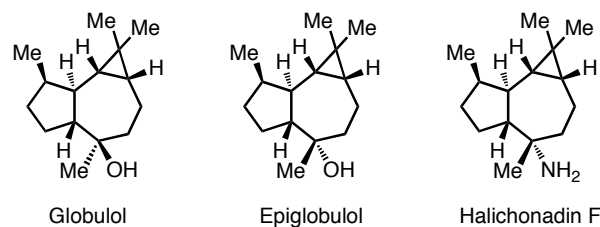
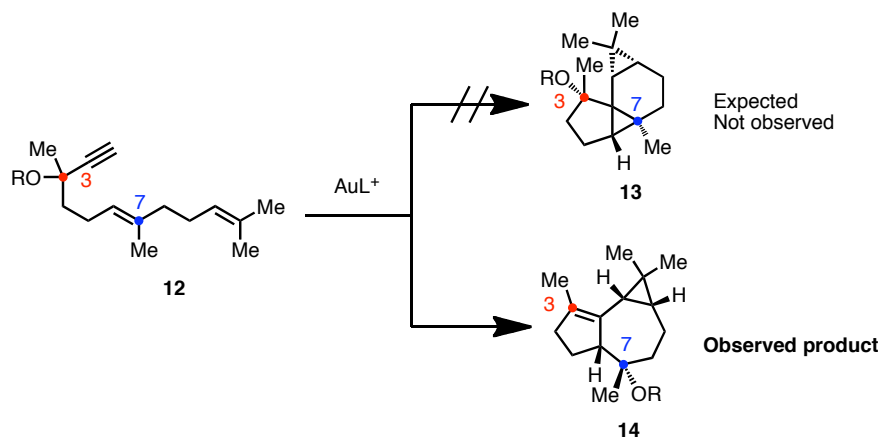

Figure 1.2. Naturally occurring sesquiterpenes of the globulol family.

In terms of bonding connectivity the 3-OR group of the starting material **12** changed to 7-OR in the cyclized product **14**. The expected compound **13** was not observed (Scheme 1.5).



Scheme 1.5. Skeletal rearrangement of 1,6-enyne **12** showing the formation of **14** by a 1,5-shift of the alkyl ether.

Mechanistically, the reaction proceeds by initial 5-*exo-dig* cyclization of **15**, to form cyclopropyl gold carbene **18**. Nucleophile *syn*-attack to the cyclopropane produces oxonium intermediate **19**, which evolves into allyl-gold cation **20a**. Trapping of **20a** by the olefin moiety following by proto-deauration lead to the final products **16a** and **16b** (Scheme 1.6).

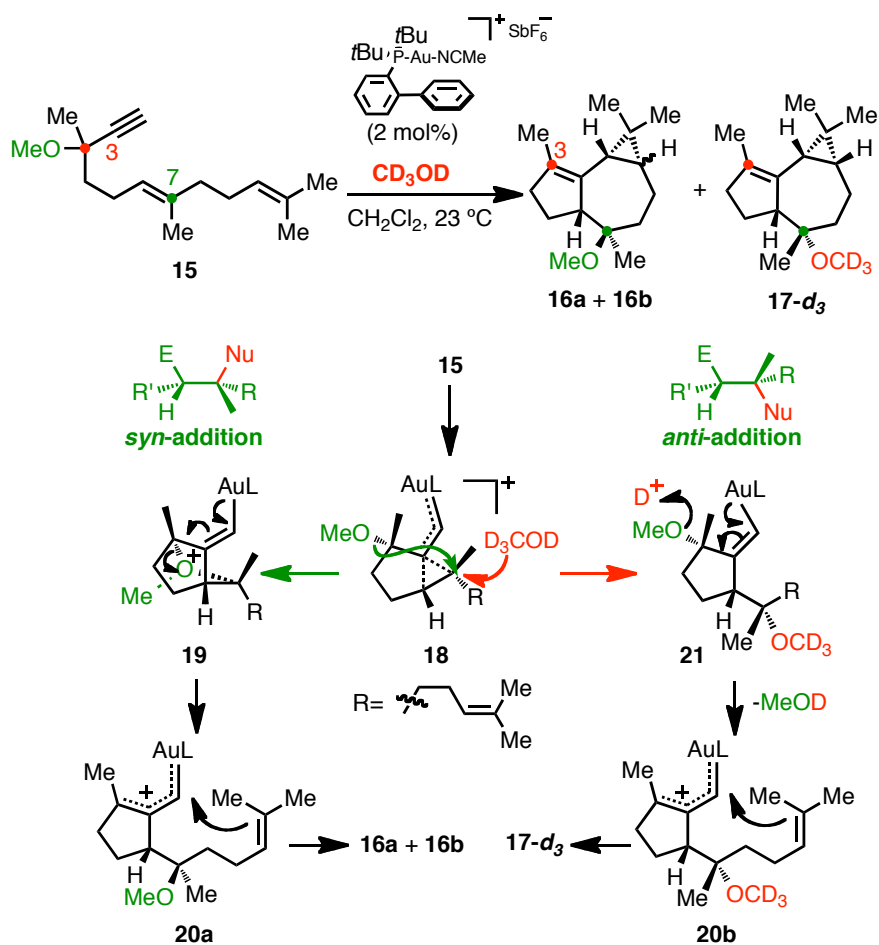

Scheme 1.6. Mechanism of skeletal rearrangement of 1,6-enynes showing the operative 1,5-shift mechanism and its verification by incorporation of labeled CD₃OD in the cyclized product.

Addition of methanol to intermediate **18** lead to **21**, which evolve to form **20b**, a diastereomer of **20a**, which finally afford **17-d₃**. As consequence, the opposite stereochemistry in carbon seven would validate our proposal about the operative 1,5-shift mechanism of reaction (Scheme 1.6).

Results and Discussion.

1,7-Enynes Bearing Methoxy Group at the Propargylic Position.

We planned to prepare 1,7-enynes **34-36** as show in scheme (scheme 1.7).

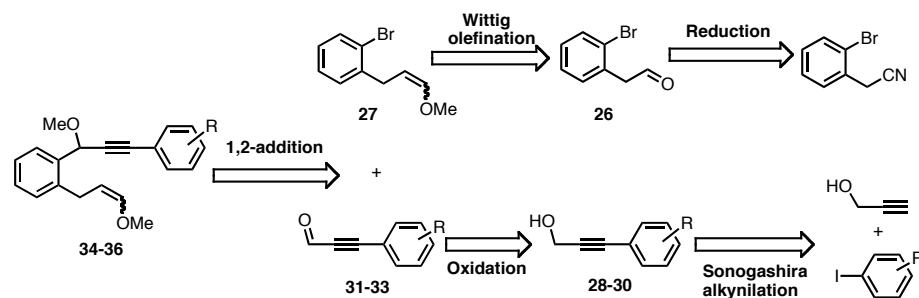

Scheme 1.7. Retrosynthetic analysis of the starting 1,7-enynes.

The synthesis of 1,7-enynes **34-36** started by the preparation of enol ether **27**. Commercially available 2-bromophenylacetonitrile was reduced with DIBAL-H in toluene at 0 °C to furnish the corresponding aldehyde **26** in quantitative yield. This aldehyde was immediately used in the next step without further purification.¹⁵⁹ Wittig olefination of aldehyde **26** yielded enol ether **27** in an overall 73% yield over two steps (Scheme 1.8).

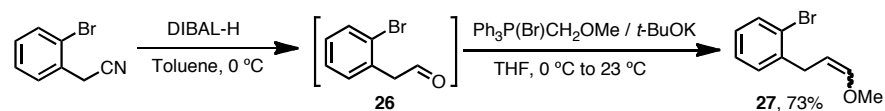

Scheme 1.8. Synthesis of enol ether **27**.

¹⁵⁹ Significant decomposition of this aldehyde was observed at room temperature.

The described fragment of the enynes corresponding to propargylic aldehydes **31-33** was synthesized by Sonogashira alkylation and oxidation. Initially Sonogashira alkylation between iodobenzene, *o*-iodotoluene and *p*-iodotoluene with propargyl alcohol gave the known 3-arylpropargyl alcohols **28**,¹⁶⁰ **29**¹⁶¹ and **30**¹⁶² in excellent yields (Scheme 1.9).

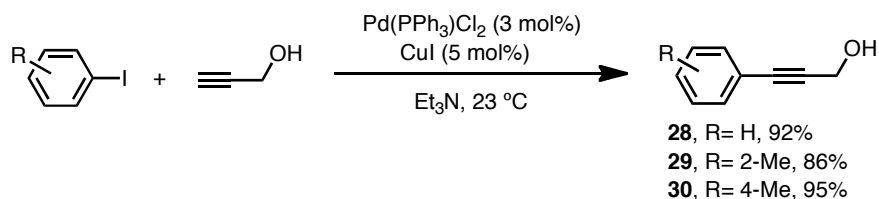

Scheme 1.9. Synthesis of 3-arylpropargyl alcohols **28-30**.

Finally, Swern oxidation of propargylic alcohols gave the aldehydes **31-33** in good yields (Scheme 1.10).

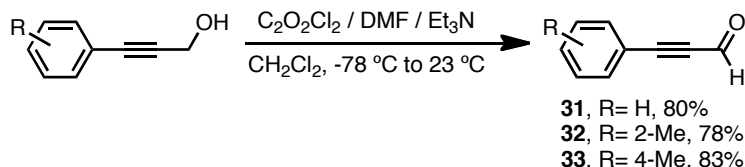

Scheme 1.10. Synthesis of aldehydes **31-33**.

The assembly of the enynes **34-36** was achieved by 1,2-addition of organolithium derivative **37** generated by metal-halogen exchange of **27** to aldehydes **31-33**. Alkylation *in situ* of adducts **38-40** with an excess of dimethyl sulfate yield the desired 1,7-enynes **34-36** (Scheme 1.11).

160 Worthy, A. D.; Candice, L. D.; Thomas, E. L.; Kian, L. T. *J. Am. Chem. Soc.* **2010**, *132*, 14757-14759.

161 Abadia, H.; Menez, P. L.; Olivier, P.; Estelle, M.; Brion, J. D.; Mouad, A. *Tetrahedron* **2010**, *66*, 698-8706.

162 Takashi, O.; Kana, S.; Taterao, M. P.; Akimori W. *J. Org. Chem.* **2011**, *76*, 3438-3449.

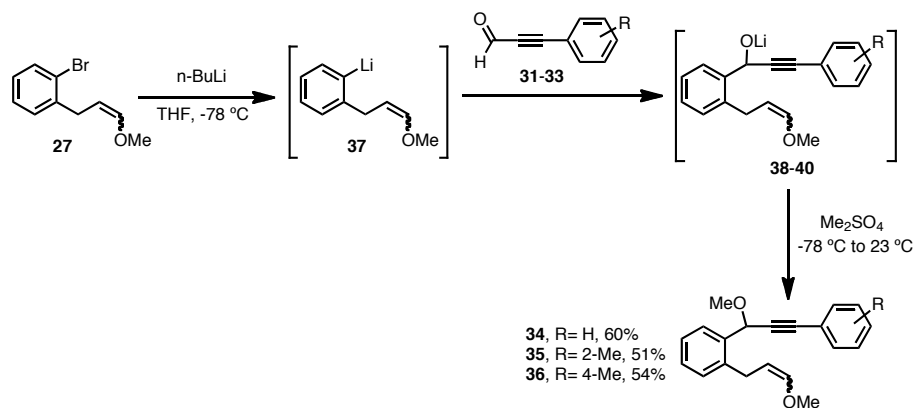

Scheme 1.11. Synthesis of 1,7-enynes **34-36**.

The first essay in the gold-catalyzed reaction were carried out using commercially available gold catalyst **C1**. The use of dry solvents as well the inert atmosphere was not necessary in these reactions. (Scheme 1.12).

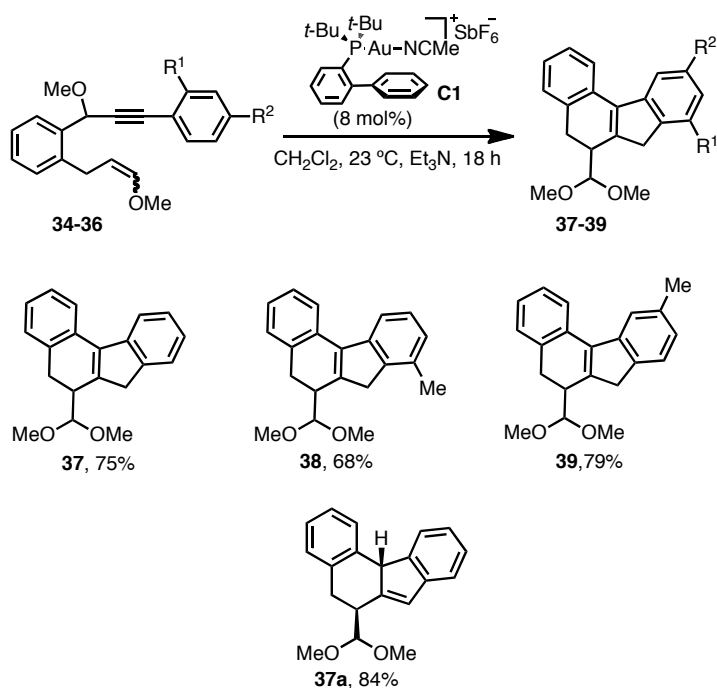

Scheme 1.12. Gold(I)-catalyzed ketal rearrangement of 1,7-enynes yielding benzo[*c*]fluorene derivatives.

The initial analysis of the resulting compounds **37-39** showed the formation of a methyl ketal. The tetracycle substrate was unambiguously assigned by exhaustive NMR spectroscopy analysis. Tetracyclic products **37-39**¹⁶³ showed the same structural motif judging by NMR. Standard treatment of the reaction involves the addition of triethylamine, in order to neutralize the Au(I) catalyst. It was observed that in absence of this basic treatment, compound **37a** was isolated in 84% yield (Scheme 1.13).

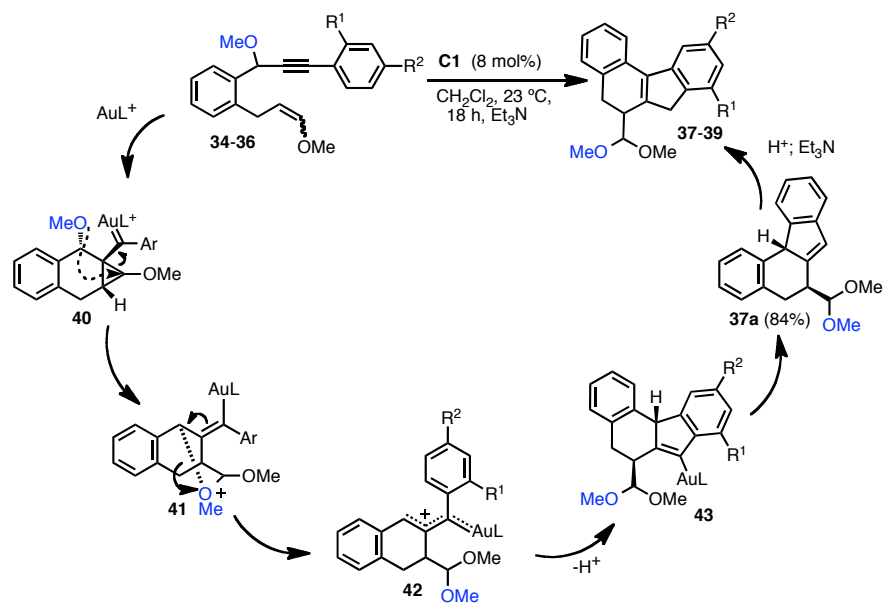

Scheme 1.13. Mechanism of skeletal rearrangement for 1,7-enynes **34-36** via allyl open carbocation. The 1,6-alcoxy shift highlighted in blue.

The mechanism of this novel transformation involves an initial 6-*exo-dig* cyclization of **34-36** to form cyclopropyl gold carbene **40**. *Syn*-attack of the alkoxy group to the cyclopropane generates vinyl-gold oxonium **41** that opens to form the key intermediate allyl-gold cation **42**. Conrotatory [2+2] Nazarov-type electrocyclic cyclization produces tetracycle **43**, which can give **37a** or benzo[C]fluorenes **37-39** with final basic treatment.

163 Jiménez-Núñez, E.; Raducan, M.; Lauterbach, T.; Molawi, K.; Solorio, C. R.; Echavarran, A. M. *Angew. Chem. Int. Ed.* **2009**, *48*, 6152-6155.

It is worth to mention that **37a** is sensitive to isomerization, and in few hours, compound **37a** is spontaneously converted in **37**. This observation means that final basic work up just accelerates the isomerization acting as catalyst, however is not necessary.

Although the transformation involves a 1-(*n*-1) migration of a OR group in a 1,*n*-enyne, as previously observed for 1,6-enyne cyclization,^{155,156} in this case, the reaction involves a novel Nazarov-type ring closing. For this electrocyclization to take place, the inicial intermediate **42'** has to equilibrate to **42**, in a reaction that was found to proceed through a small barrier, according to preliminar DFT calculations (Scheme 1.14).

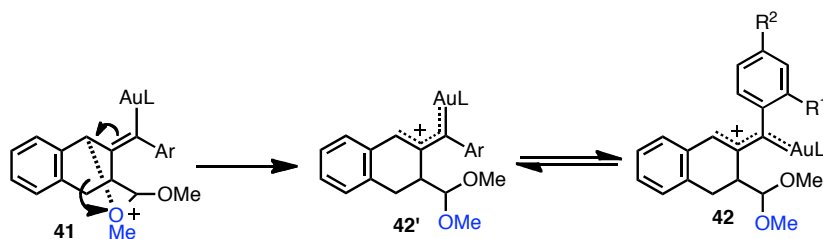

Scheme 1.14. Isomerization of allyl-gold cation **42'**.

Conclusions

- A new reactivity in gold(I)-catalyzed cyclization of 1,6- as well as 1,7-enynes containing propargylic ethers was discovered. For 1,6-enynes, the developed methodology was successfully applied to the synthesis of some naturally occurring compounds. For the case of 1,7-enynes, a 1,6-shift took place with concomitant [2+2] Nazarov-type electrocyclization leading to the formation of benzo[C]fluorenes.

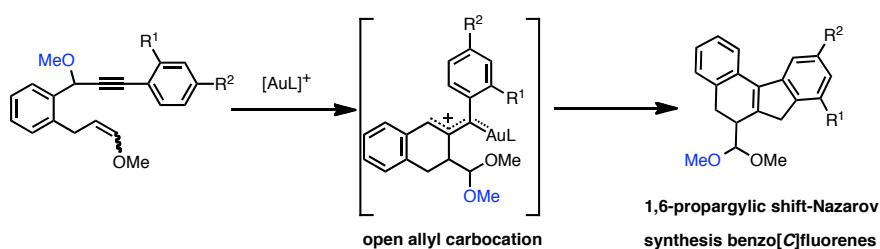

Experimental section

1-Bromo-2-(3-methoxyallyl)benzene (27).

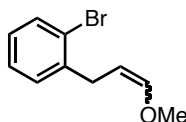

A solution of DIBAL-H in toluene (1.00 M, 16.1 mL, 16.1 mmol) was added in one portion to a solution of 2-(2-bromophenyl)acetonitrile (3.00 g, 15.3 mmol) in toluene (35 mL) at 0 °C. After stirring at this temperature for 5 min the reaction was carefully quenched by addition of aq. HCl solution (10%, 100 mL). The aqueous phase was extracted with EtOAc (50 mL), the organic phase was washed with aq. HCl solution (10%, 2x100 mL) and brine (100 mL) and dried over MgSO₄. After evaporation of the solvents the crude 2-(2-bromophenyl)acetaldehyde was obtained as a light yellow oil which was used immediately in the following reaction.

Potassium tert-butoxide (1.98 g, 17.7 mmol) was added in portions to a suspension of (methoxymethyl)triphenylphosphonium chloride (5.77 g, 16.8 mmol) in THF (20 mL) at 0 °C. The color of the mixture turned from dark orange to red. After stirring for 40 min at 0 °C the reaction was allowed to warm up to room temperature. Then a solution of the crude 2-(2-bromophenyl)acetaldehyde in THF (10 mL) was added dropwise and the mixture was stirred overnight. The reaction was quenched by addition of sat. aq. NH₄Cl solution and the aqueous phase was extracted with EtOAc. The combined organic layers were dried over MgSO₄ and the solvents were evaporated. Chromatographic purification (30:1 hexane/EtOAc) of the crude material yielded 1-bromo-2-(3-methoxyallyl)benzene as a yellow oil (2.53 g, 73%, *E/Z* 1:1.1).

¹H NMR (400 MHz, CDCl₃) δ 7.56-7.53 (m, 2H, *E+Z*), 7.37-7.30 (m, 2H, *E+Z*), 7.28-7.23 (m, 2H, *E+Z*), 7.11-7.04 (m, 2H, *E+Z*), 6.45 (dt, *J* = 12.5, 1.2 Hz, 1H, *E*), 6.06 (dt, *J* = 6.2, 1.4 Hz, 1H, *Z*), 4.90 (dt, *J* = 12.3, 2.7 Hz, 1H, *E*), 4.59 (dq, *J* = 6.0, 1.7 Hz, 1H, *Z*), 3.66 (s, 3H), 3.57 (s, 3H), 3.54 (dd, *J* = 7.2, 1.4 Hz, 2H, *E*),

3.39 (dd, $J = 7.4, 1.2$ Hz, 2H, Z).

^{13}C NMR (100 MHz, CDCl_3) δ 149.0 (CH, E), 147.5 (CH, Z), 134.0 (CH), 133.8 (CH), 132.9 (CH), 132.8 (CH), 130.2 (CH), 128.9 (CH), 128.7(CH), 128.6 (CH), 127.8 (CH), 127.7 (CH), 127.6 (C), 127.60 (C), 103.7 (CH, E), 100.26 (CH, Z), 59.9 (CH, E), 56.2 (CH₃, Z), 34.47 (CH₂, E), 30.84 (CH₂, Z). HRMS-ESI calcd for $\text{C}_{10}\text{H}_{12}\text{BrO}$ ($M+H$): 227.0066; found: 227.0071.

1-(1-Methoxy-3-phenylprop-2-ynyl)-2-(3-methoxyallyl)benzene (34).

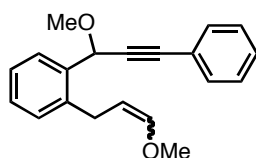

n-BuLi (2.00 M in toluene, 2.29 mL, 4.58 mmol) was added dropwise to a solution of 1-bromo-2-(3-methoxyallyl)benzene (945 mg, 4.16 mmol) in dry THF (10 mL) at -78 °C. After stirring for 40 min at this temperature a solution of 3-phenylpropionaldehyde (487 mg, 3.74 mmol) in dry THF (3 mL) was added dropwise and the mixture was stirred for 10 min. Then dimethyl sulfate (1.05 g, 8.32 mmol) was added in one portion and the reaction is allowed to warm up to room temperature. After stirring for 2 h the reaction was stopped by addition of sat. aq. NH_4Cl solution. The aqueous phase was extracted with EtOAc, the combined organic layers were dried over MgSO_4 , and the solvent was evaporated. Chromatographic purification (25:1 hexane/EtOAc) of the crude material yielded **34** (730 mg, 60%, *E/Z* 1.5:1) as an amber oil.

^1H NMR (400 MHz, CDCl_3) δ 7.72-7.68 (m, 2H, *E+Z*), 7.48-7.46 (m, 4H, *E+Z*), 7.32- 7.30 (m, 6H, *E+Z*), 7.27-7.25 (m, 6H, *E+Z*), 6.39 (d, $J = 12.6$ Hz, 1H, *E*), 5.99 (d, $J = 6.2$ Hz, 1H, Z), 5.52 (s, 1H, Z), 5.49 (s, 1H, *E*), 4.93 (dt, $J = 12.7, 6.7$ Hz, 1H, *E*), 4.55 (q, $J = 7.0$ Hz, 1H, Z), 3.66 (s, 3H), 3.51 (s, 6H), 3.50 (s, 3H), 3.47 (bs, 2H, *E*), 3.45 (bs, 2H, Z).

^{13}C NMR (100 MHz, CDCl_3) δ 148.3 (CH, *E*), 146.5 (CH, Z), 139.9 (C, Z), 139.7 (C, *E*), 136.4 (C, Z), 136.2 (C, *E*) 131.9 (2xCH), 129.8 (CH), 129.7 (CH), 128.8 (CH), 128.6 (CH), 128.5 (CH), 128.4(2xCH), 128.3 (CH), 128.1 (CH), 128.0

(CH), 126.5 (CH), 126.4 (CH), 122.9 (CH, *Z*), 122.8 (CH, *E*), 105.4 (CH, *Z*), 101.7 (CH, *E*), 87.9 (C, *E*), 87.6 (C, *Z*), 87.2 (C, *Z*), 86.9 (C, *Z*), 71.2 (CH₂, *E*), 70.9 (CH₂, *Z*), 59.7(CH), 56.4(CH), 56.3(CH), 56.0(CH), 30.7 (CH, *E*), 27.2 (CH, *Z*).

1-(3-Methoxy-3-(2-(3-methoxyallyl)phenyl)prop-1-ynyl)-2-methylbenzene (35).

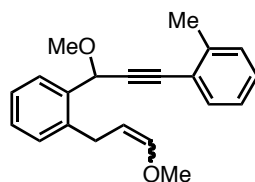

This compound was prepared according to the procedure for **34** using 3-*o*-tolylpropionaldehyde. Flash chromatography (25:1 hexane/EtOAc), yellow oil (51%, *E/Z* 2:1).

¹H NMR (400 MHz, CDCl₃) δ 7.78-7.75 (m, 2H, *E+Z*), 7.48 (d, *J* = 7.5 Hz, 2H, *E+Z*), 7.33-7.22 (m, 10H, *E+Z*), 7.19-7.15 (m, 2H *E+Z*), 6.42 (d, *J* = 12.7 Hz, 1H, *E*), 6.03 (dt, *J* = 6.0, 1.5 Hz, 1H, *Z*), 5.61 (s, 1H, *Z*), 5.59 (s, 1H, *E*), 4.96 (dt, *J* = 12.7, 6.9 Hz, 1H, *E*), 4.59 (q, *J* = 7.0 Hz, 1H, *Z*), 3.69 (s, 3H, *Z*), 3.56 (s, 3H, *Z*), 3.55 (s, 3H, *E*), 3.54 (s, 3H, *E*), 3.51 (bs, 2H, *E+Z*), 3.49 (bs, 2H, *E+Z*), 2.49 (s, 3H, *E+Z*).

¹³C NMR (100 MHz, CDCl₃) δ 148.4 (CH, *E*), 146.6 (CH, *Z*), 140.4 (C, *E+Z*), 139.9 (C, *Z*), 139.7 (C, *E*), 136.6 (C, *Z*), 136.4 (C, *E*), 132.3 (CH), 129.8 (CH), 129.7 (CH), 129.6 (CH), 129.5 (CH), 128.8 (CH), 128.7 (CH), 128.6 (CH), 128.5 (CH), 128.1 (CH), 128.0 (CH), 126.5 (CH), 126.4 (CH), 125.7 (CH), 125.6 (CH), 122.7 (C, *Z*), 122.6 (C, *E*), 105.4 (CH, *Z*), 101.7 (CH, *E*), 91.1 (C, *Z*), 90.8 (C, *E*), 86.9 (C, *E*), 86.6 (C, *Z*), 71.3 (CH, *E*), 71.0 (CH, *Z*), 59.7 (CH₃, *Z*), 56.3 (CH₃, *Z*), 56.2 (CH₃, *E*), 56.1 (CH₃, *E*), 30.7 (CH₂, *E*), 27.3 (CH₂, *Z*), 20.9 (CH₃).

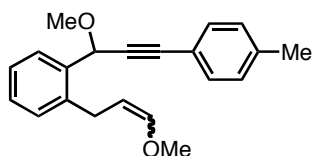
1-(1-Methoxy-3-*p*-tolylprop-2-ynyl)-2-(3-methoxyallyl)benzene (36).

This compound was prepared according to the procedure for **34** using 3-*p*-tolylpropionaldehyde. Flash chromatography (25:1 hexane/EtOAc), yellow oil (54%, *E/Z* 1.7:1).

^1H NMR (400 MHz, CDCl_3) δ 7.72-7.68 (m, 2H, *E+Z*), 7.36 (d, $J = 8.0$ Hz, 4 H, *E+Z*), 7.29-7.22 (m, 6 H, *E+Z*), 7.11 (d, $J = 8.0$ Hz, 4 H, *E+Z*), 6.39 (d, $J = 12.6$ Hz, 1H, *E*), 5.99 (dt, $J = 6.1, 1.5$ Hz, 1H, *Z*), 5.51 (s, 1H, *Z*), 5.49 (s, 1H, *E*), 4.93 (dt, $J = 12.7, 7.0$ Hz, 1H, *E*), 4.55 (q, $J = 6.8$ Hz, 1H, *Z*), 3.66 (s, 3H), 3.51 (s, 3H), 3.50 (s, 3H), 3.49 (s, 3H), 3.47 (bs, 2H, *E*), 3.45 (bs, 2H, *Z*), 2.35 (s, 6H, *E+Z*).

^{13}C NMR (100 MHz, CDCl_3) δ 148.4 (CH, *E*), 146.6 (CH, *Z*), 140.0 (C, *Z*), 139.8 (C, *E*), 138.8 (C, *E*), 138.6 (C, *Z*), 136.6 (C, *Z*), 136.4 (C, *E*), 131.8 (2xCH), 129.8 (CH), 129.7 (2xCH), 129.2 (CH), 129.1 (CH), 128.7 (CH), 128.2 (CH), 128.1 (CH), 126.5 (CH), 126.4 (CH), 119.8 (C, *Z*), 119.7 (C, *E*), 105.4 (CH, *Z*), 101.7 (CH, *E*), 88.0 (C, *E*), 87.8 (C, *Z*), 86.5 (C, *Z*), 86.2 (C, *E*), 71.3 (CH, *E*), 71.0 (CH, *Z*), 59.8 (CH₃), 56.4 (CH₃), 56.3 (CH₃), 56.1 (CH₃), 30.7 (CH₂, *E*), 27.3 (CH₂, *Z*), 21.6 (CH₃, *E+Z*). HRMS-ESI calcd for $\text{C}_{21}\text{H}_{23}\text{O}_2$ ($M+H$)⁺: 307.1693; found: 307.1677.

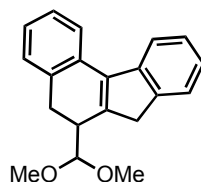
6-(Dimethoxymethyl)-6,7-dihydro-5*H*-benzo[*c*]fluorene (37).

Gold (I) catalyst **C1** (19 mg, 0.024 mmol) was added to a solution of enyne **34**

(89 mg, 0.30 mmol) in CH₂Cl₂ (3 mL). After stirring for 18 h the reaction was stopped by addition of two drops of Et₃N and stirring for additional 5 min. Removal of the solvent followed by flash chromatography (25:1 hexane/AcOEt) yielded **37** (68 mg, 75 %) as a yellow oil.

¹H NMR (400 MHz, CDCl₃) δ 7.90 (t, *J* = 6.5 Hz, 2H), 7.50 (d, *J* = 7.4 Hz, 1H), 7.37- 7.29 (m, 3H), 7.24-7.19 (m, 2H), 4.23-4.19 (m, 1H), 3.74 (d, *J* = 24.0 Hz, 1H), 3.54 (d, *J* = 24.0 Hz, 1H), 3.39 (s, 3H), 3.30 (s, 3H), 3.04-2.95 (m, 3H).

¹³C NMR (100 MHz, CDCl₃) δ 145.3 (C), 144.5 (C), 142.6 (C), 136.1 (C), 135.4 (C), 132.5 (C), 128.6 (CH), 127.0 (CH), 126.8 (CH), 126.4 (CH), 124.5 (CH), 124.1 (CH), 123.2 (CH), 120.5 (CH), 104.4 (CH), 55.1 (CH₃), 53.3 (CH₃), 40.9 (CH₂), 38.5 (CH), 31.3 (CH₂). MALDI calcd for C₂₀H₁₈O₂ (M-H₂)⁺ 290.1301; found: 290.1272.

6-(Dimethoxymethyl)-8-methyl-6,7-dihydro-5H-benzo[*c*]fluorene (**38**).

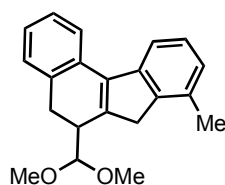

This compound was prepared according to the procedure for **37** using enyne **35**. Flash chromatography (25:1 hexane/EtOAc), brownish oil (68%).

¹H NMR (400 MHz, CDCl₃) δ 7.90 (d, *J* = 7.7 Hz, 1H), 7.77 (d, *J* = 7.6 Hz, 1H), 7.35-7.28 (m, 3H), 7.24-7.20 (m, 1H), 7.06 (d, *J* = 7.6 Hz, 1H), 4.23- 4.21 (m, 1H), 3.65 (d, *J* = 24.0 Hz, 1H), 3.50 (d, *J* = 24.0 Hz, 1H), 3.40 (s, 3H), 3.31 (s, 3H), 3.06-2.96 (m, 3H), 2.42 (s, 3H).

¹³C NMR (100 MHz, CDCl₃) δ 144.8 (C), 143.0 (C), 142.2 (C), 136.4 (C), 135.4 (C), 133.2 (C), 132.6 (C), 128.6 (CH), 126.9 (CH), 126.8 (CH), 126.7 (CH), 125.8 (CH), 123.2 (CH), 118.3 (CH), 105.3 (CH), 55.2 (CH₃), 53.2 (CH₃), 39.9 (CH₂), 38.5 (CH₂), 31.3 (CH), 19.0 (CH₃). HRMS-ESI calcd for C₂₁H₂₃O₂ (M+H)⁺: 307.1693; found: 307.1677.

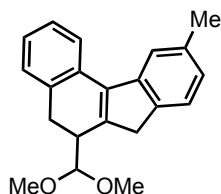
6-(Dimethoxymethyl)-10-methyl-6,7-dihydro-5H-benzo[c]fluorene (39).

This compound was prepared according to the procedure for **37** using enyne **36**. Flash chromatography (25:1 hexane/EtOAc), brownish oil (79%).

^1H NMR (400 MHz, CDCl_3) δ 7.91 (d, $J = 7.5$ Hz, 1H), 7.73 (s, 1H), 7.39-7.28 (m, 3H), 7.22-7.19 (m, 1H), 7.05 (d, $J = 7.5$ Hz, 1H), 4.20-4.19 (m, 1H), 3.70 (d, $J = 24.0$ Hz, 1H), 3.49 (d, $J = 24.0$ Hz, 1H), 3.38 (s, 3H), 3.29 (s, 3H), 3.04-2.94 (m, 3H), 2.46 (s, 3H).

^{13}C NMR (100 MHz, CDCl_3) δ 145.6 (C), 142.9 (C), 141.5 (C), 136.0 (C), 135.9 (C), 135.4 (C), 132.6 (C), 128.6 (CH), 126.9 (CH), 126.8 (CH), 125.3 (CH), 123.8 (CH), 123.2 (CH), 121.4 (CH), 105.4 (CH), 55.2 (CH₃), 53.3 (CH₃), 40.5 (CH₂), 38.5 (CH₂), 31.3 (CH), 22.0 (CH₃). HRMS-ESI calcd for $\text{C}_{20}\text{H}_{19}\text{O}_2$ (M-OMe)⁺: 275.1430, found: 275.1420.

(6*R,11*bS**)-6-(dimethoxymethyl)-6,11*b*-dihydro-5*H*-benzo[*c*]fluorene (37a)**

Gold (I) catalyst **C1** (13 mg, 0.017 mmol) was added to a solution of enyne **34** (62 mg, 0.21 mmol) in CH_2Cl_2 (2 mL). After stirring for 18 h the solvent was evaporated and the residue was purified by preparative TLC (25:1 hexane/EtOAc) to yield **37a** (52 mg, 84 %) as a yellow oil.

^1H NMR (400 MHz, CDCl_3) δ 7.78 (d, $J = 7.2$ Hz, 1H), 7.48 (t, $J = 3.9$ Hz, 1H),

7.37- 7.23 (m, 4 H), 7.18-7.15 (m, 2H), 6.68 (t, $J = 1.4$ Hz, 1H), 4.47 (d, $J = 6.6$ Hz, 1H), 4.45 (bs, 1H), 3.47 (s, 3H), 3.45 (s, 3H), 3.19-3.16 (m, 1H), 3.04 (m, 2H).

^{13}C NMR (100 MHz, CDCl_3) δ 149.4 (C), 146.1 (C), 143.1 (C), 138.1 (C), 135.8 (C), 128.1 (CH), 127.2 (CH), 126.6 (CH), 126.5 (CH) 126.1 (CH), 125.5 (CH), 124.5 (CH), 124.0 (CH), 121.4 (CH), 107.2 (CH), 54.9 (CH₃), 54.6 (CH₃), 52.3 (CH), 40.0 (CH), 32.2 (CH₂).

This compound undergoes facile dehydrogenation (presumably to form the 7-(dimethoxymethyl)-7*H*-benzo[*c*]fluorene) in the mass spectrometer. HRMS-LDI calcd for $\text{C}_{20}\text{H}_{18}\text{O}_2$ (M-H₂)⁺ 290.1301; found: 290.1278.

CHAPTER II

Gold(I)-Catalyzed Annulation Via Retro-Cyclopropanation

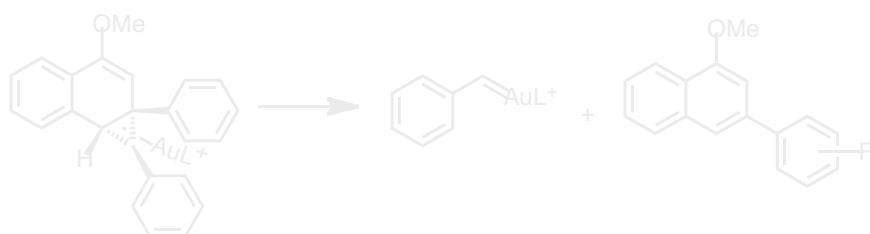

UNIVERSITAT ROVIRA I VIRGILI
GOLD (I)-CATALYZED RETRO-CYCLOPROPANATION REACTION AND DEVELOPMENT OF TRINDANE-BASED
APPROACH TOWARD C60
Cesar Rogelio Solorio Alvarado
DL: T. 1714-2011

CHAPTER II

Introduction

Metal-catalyzed reactions of 1,*n*-enynes lead to a wide variety of cyclic compounds under mild conditions.^{164,165} Recently we found that 1,*n*-enynes bearing propargyl alcohols, ethers, and silyl ethers react with cationic gold(I) catalysts by a new type of cyclization in which the OR group undergoes a (1,*n*-1)-migration (chapter I).¹⁶³ However, when we tried the gold-catalyzed cyclization of 1,6-enynes **44** and **45**, very different results were obtained. In this case we found two new annulation processes involving fragmentation of the skeleton of the starting enyne. Such fragmentation produces naphthalenes of the type **47**. However the formation of naphthalenes such as **46** is explained by a gold(I)-promoted retro-cyclopropanation reaction, releasing additionally free gold carbenes of the type **48**. In both processes, we could synthesize 1,3-disubstituted naphthalenes (Scheme 2.1).

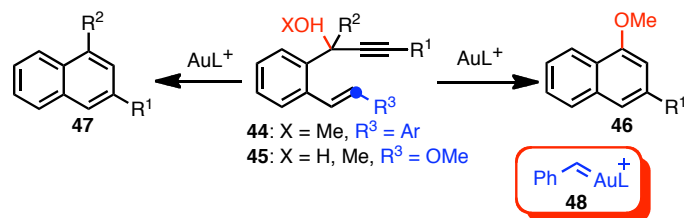

Scheme 2.1. Gold(I)-catalyzed new annulation processes of 1,6-enynes bearing propargyl ethers.

There is only one precedent for the retro-cyclopropanation reaction with electrophilic metal catalyst. Gassman reported the cleavage of cyclopropanes to

164 (a) Jiménez-Núñez, E.; Echavarren, A. M. *Chem. Rev.* **2008**, *108*, 3326-3350. (b) Gorin, D. J.; Sherry, B. D.; Toste, F. D. *Chem. Rev.* **2008**, *108*, 3351-3378. (c) Michelet, V.; Toullec, P. Y.; Genêt, J.-P. *Angew. Chem. Int. Ed.* **2008**, *47*, 4268-4315. (d) Fürstner, A. *Chem. Soc. Rev.* **2009**, *38*, 3208-3221.

165 Kirsch, S. *Synthesis* **2008**, 3183-3204.

form metal carbenes using $\text{PhWCl}_3/\text{AlCl}_2$ ($\text{R} = \text{Et}, \text{Cl}$). The reaction was proposed to take place via four-membered ring metallacycles to generate the alkenes and metalcarbenes (Scheme 2.2).¹⁶⁶

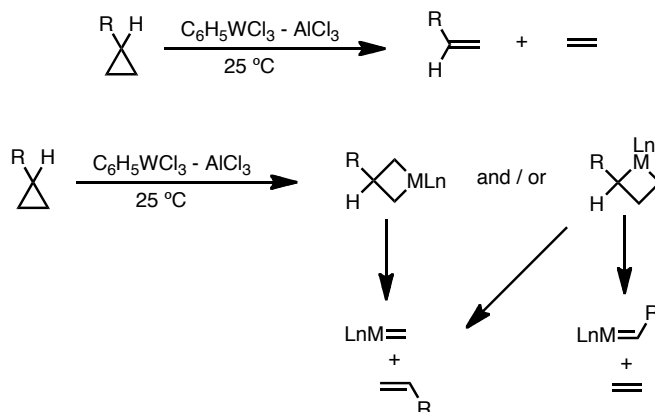

Scheme 2.2. Tungsten(IV)/Aluminium(III)-catalyzed retro-cyclopropanation.

Noyori described a related process for highly strained bicyclo[1.1.0]butanes, which involves retro-cyclopropanation with $\text{Ni}(0)$ via an oxidative addition reaction (Scheme 2.3).¹⁶⁷

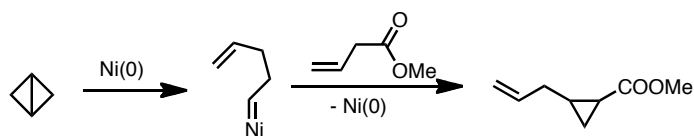

Scheme 2.3. $\text{Ni}(0)$ -catalyzed retro-cyclopropanation via oxidative addition.

Additionally Wipf demonstrated that $\text{Rh}(I)$ is able to catalyze the retro-cyclopropanation process from strained bicyclobutanes (Scheme 2.4).¹⁶⁸

166 (a) Gassman, P. G.; Johnson, T. H. *J. Am. Chem. Soc.* **1976**, *98*, 6057-6058. (b) Gassman, P. G.; Johnson, T. H. *J. Am. Chem. Soc.* **1976**, *98*, 6058-6059.

167 Takaya, H.; Suzuki, T.; Kumagai, Y.; Hosoya, M.; Kawauchi, H. Noyori, R. *J. Org. Chem.* **1981**, *46*, 2854-2861.

168 Walczak, M. A. A.; Wipf, P. *J. Am. Chem. Soc.* **2008**, *130*, 6924-6925.

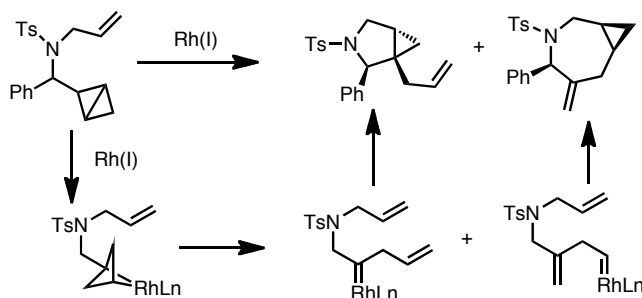
**Scheme 2.4.** Rh(I)-catalyzed retro-cyclopropanation via oxidative addition.

Reductive retro-cyclopropanation reaction is a well-known reaction of fullerenes, as described by Echegoyen and co-workers, the reaction can be carried out electrochemically or with chemical reductants (Scheme 2.5).¹⁶⁹

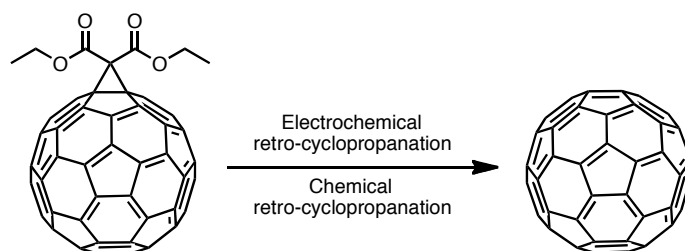
**Scheme 2.5.** Electrochemical retro-cyclopropanation reaction in fullerene.

Finally, it is important to mention that recently the group of Chen proposed the gas-phase cleavage of 1-ethoxy-2-methoxycyclopropane with $[\text{AuIMes}]^+$ (IMes = 1,3-bis(2,4,6-trimethylphenyl)imidazol-2-ylidene) which involves a retro-cyclopropanation reaction according to CID experiments and theoretical calculations (Scheme 2.6).¹⁷⁰

169 Herranz, M. Á.; Cox, C. T.; Echegoyen, L. *J. Org. Chem.* **2003**, *68*, 5009-5012.

170 (a) Batiste, L.; Fedorov, A.; Chen, P. *Chem. Commun.* **2010**, *46*, 3899-3901. (c) Fedorov, A.; Chen, P. *Organometallics* **2010**, *29*, 2994-3000. (d) Fedorov, A.; Batiste, L.; Bach, A.; Birney, D. M.; Chen, P. *J. Am. Chem. Soc.* **2011**, *133*, 12162-12171. (e) For other metal-promoted gas-phase retro-cyclopropanations: Eller, K.; Schwarz, H. *Chem. Rev.* **1991**, *91*, 1121-1177.

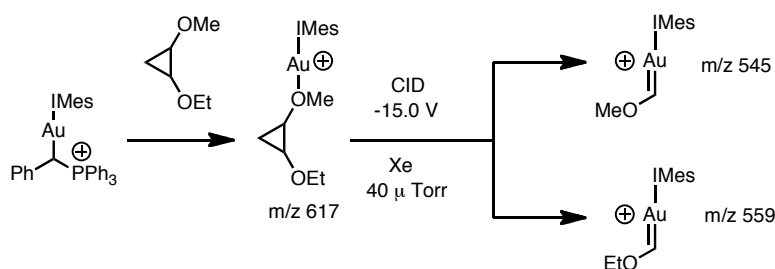

Scheme 2.6. Gold(I)-promoted gas phase retro-cyclopropanation.

Results and Discussion

Initially, we studied the annulation reaction of enynes **44a-i** to form naphthalenes **46**. These enynes were readily synthesized in a sequence that involved a starting Wittig olefination of 2-bromobenzaldehyde to form **49** followed by metal-halogen exchange to generate **50**.

Propargyl alcohols **51-59** and **93** were synthesized by Sonogashira alkylation of propargyl alcohol and a variety of substituted iodobenzenes. Oxidation reaction of propargyl alcohols **51-59** and **93** delivered the corresponding aldehydes **60-68**. A 1,2-addition reaction of organometallic species **50** to aldehydes **60-68** and **92** followed by *in situ* methylation furnished the desired enynes **44a-i** (scheme 2.7).

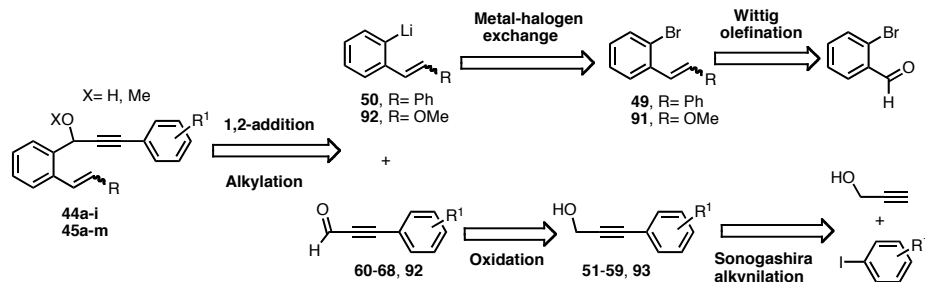

Scheme 2.7. Retrosynthetic analysis of enynes **44a-i** and **45a-m**.

Synthesis of **49** was achieved in 95% yield following the described procedure.¹⁷¹ Propargyl alcohols **51-59** and **93** were synthesized in 86-96% yields by Sonogashira alkylation. Swern oxidation of **51-59** and **93** yielded aldehydes **60-68** and **94** in 70-83% yield (Scheme 2.8).

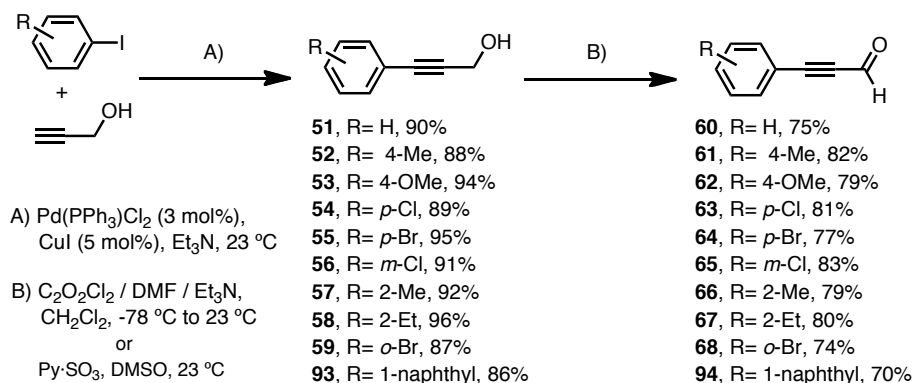

Scheme 2.8. Synthesis of aldehydes **60-68** and **94**.

Metal-halogen exchange of **49** generated intermediate **50**, which was treated with aldehydes **60-68** to give the 1,2-addition products corresponding to the enynes **44' a-i** (Scheme 2.9).

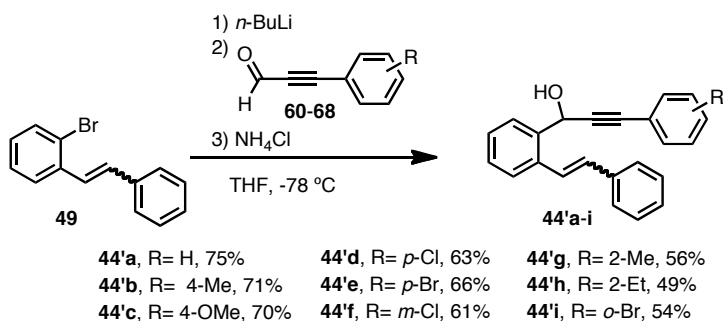

Scheme 2.9. Synthesis of enynes **44' a-i**.

¹⁷¹ He, Z.; Yudin, A. K. *Org. Lett.* **2006**, *8*, 5829-5832.

The cyclization of enynes **44'a-i** bearing propargyl alcohols was also tested in gold catalysis. Thus, after treatment with cationic complex **C1**, tricyclic ketones **69a-i** were obtained in one stereospecific cycloisomerization. The relative configuration was assigned by NOESY experiments (Scheme 2.10).

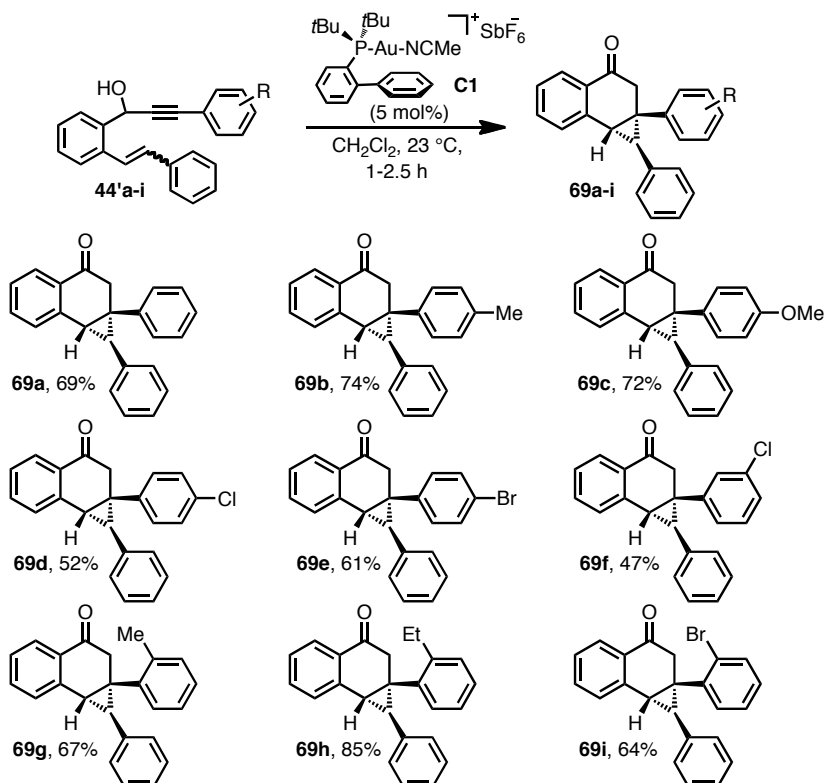

Scheme 2.10. Stereospecific cycloisomerization of enynes **44'a-i**.

This cycloisomerization follows a mechanism similar to that reported with Pt(II) salts.¹⁷² Initial stereospecific 6-*endo*-dig cycloisomerization of **44'a-i** forms gold(I) carbene **70**, which is followed by [1,2]-hydride shift that generates **71**.

172 Related cycloisomerization of hydroxylated enynes: (a) Mamane, V.; Gress, T.; Krause, H.; Fürstner, A. *J. Am. Chem. Soc.* **2004**, *126*, 8654-8655. (b) Harrak, Y.; Blaszykowsky, C.; Bernard, M.; Cariou, K.; Mainetti, E.; Mouriès, V.; Dhimane, A.-L.; Fensterbanck, L.; Malacria, M. *J. Am. Chem. Soc.* **2004**, *126*, 8656-8657.

Elimination of the metal regenerates the catalyst forming the enol **72**, which undergo tautomerization to yield ketones **69a-i** (Scheme 2.11).

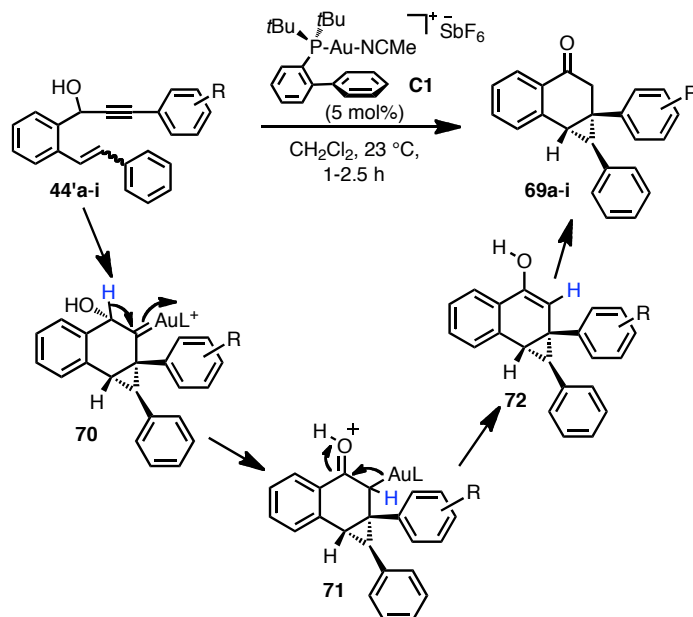

Scheme 2.11. Mechanism of gold(I)-catalyzed cycloisomerization of enynes **44'a-i**.

Methyl ether derivatives **44a-j** were easily synthesized in 54-93% yield from propargylic alcohols **44'a-i** by methylation with NaH and excess of Me₂SO₄ (Scheme 2.12).

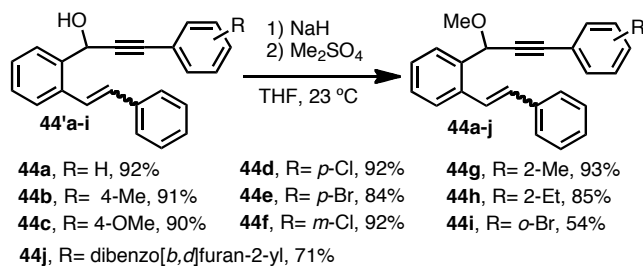

Scheme 2.12. Synthesis of enynes **44a-j** bearing a propargyl methyl ether.

Methyl ethers **44a-j** reacted with gold(I) complex **C1** to give 3-aryl-1-methoxynaphthalenes **73a-j** in 45-71% yields. In addition to the naphthalenes products (Scheme 2.13), we also isolated biscyclopropanes **74a-d** with an extra -CHPh unit (Scheme 2.14).

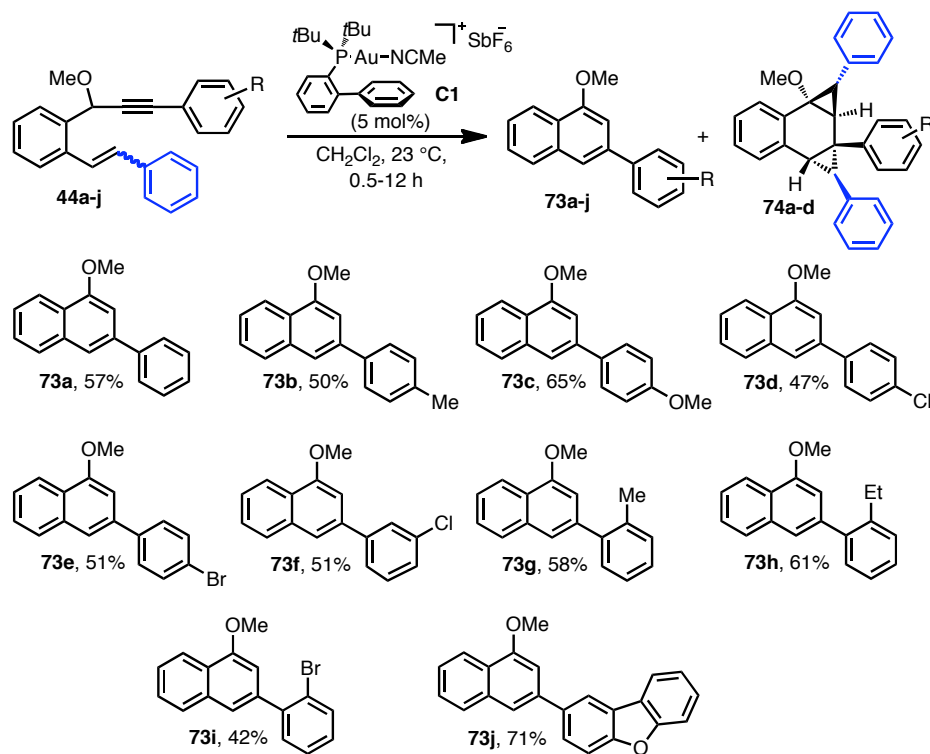

Scheme 2.13. Gold(I)-catalyzed synthesis of 1,3-disubstituted naphthalenes by annulation/fragmentation of starting enyne.

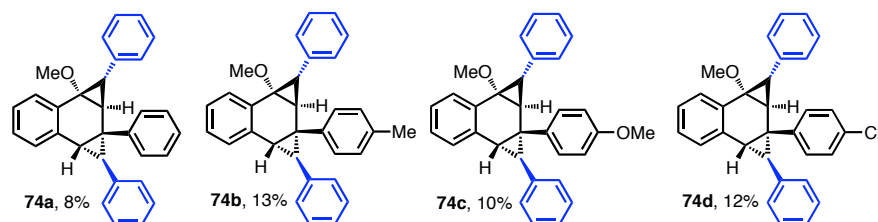

Scheme 2.14. Additional biscyclopropanes **74a-d** isolated in the annulation/fragmentation reaction of enynes **44a-j**.

The reaction takes place efficiently with substrates bearing electron-neutral (**73a**), electron-donating (**73b-c, g-h**) as well as electron-attracting (**73d-f, i**) groups even hetero aryls (**73j**). Formation of compounds **74a-d** suggests that gold(I) carbene **48** is formed in the fragmentation process and is cyclopropanating the enol ether **77**, one of the reaction intermediates (Scheme 2.15).

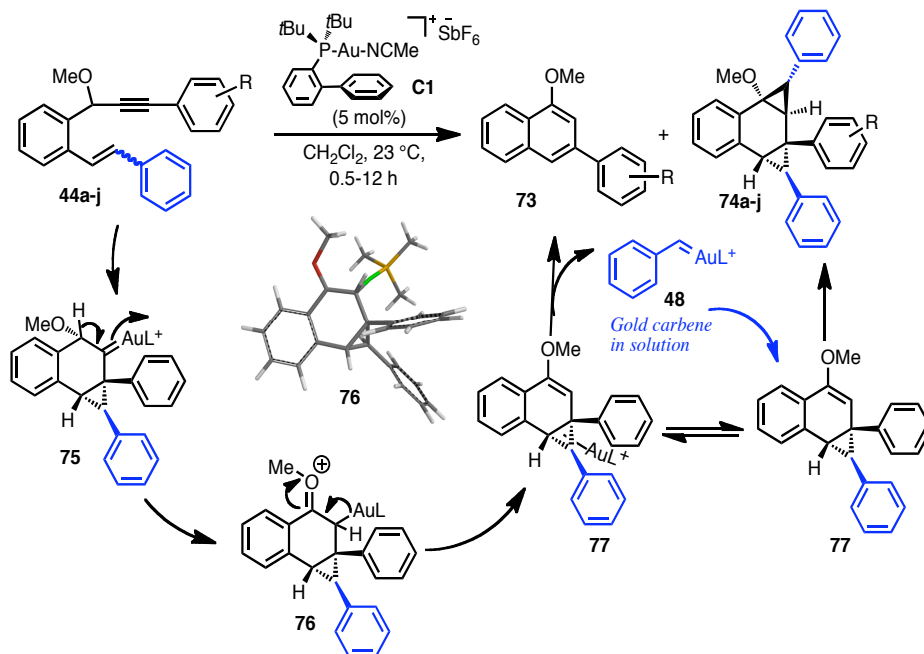

Scheme 2.15. Mechanism of gold(I)-catalyzed synthesis of **73** and **74** by retro-cyclopropanation leading the formation of free gold carbene **48**.

These results are consistent with a mechanism proceeding by the 6-endo-dig gold(I)-promoted cyclization of enynes **44a-j** to form **75**, followed by a 1,2-H shift^{173a} to form alkenyl-gold(I) complex **76**^{173b} (Scheme 2.15). The isomer of **76** with AuL in the convex face would be formed similarly from the C-1 epimer of

173 (a) For a theoretical study relevant to this 1,2-H shift: Shi, F.-Q.; Li, X.; Xia, Y.; Zhang, L.; Yu, Z.-X. *J. Am. Chem. Soc.* **2007**, *129*, 15503-15512. (b) DFT calculations (B3LYP 6-31G** (C,H,O,P), LANL2DZ (Au) (Spartan 08); L = PMe₃) show that these intermediates type **76** are η^1 -Au complexes.

intermediate **75**. Retro-cyclopropanation¹⁷⁴ via **77**, presumably by stepwise cleavage by electrophilic AuL⁺, would then yield naphthalenes **73** and free gold(I) carbene **48**, which cyclopropanates **77** to give bicyclopropanes **74a-j**.

To confirm the formation of free **48**, we first carried out the reaction of a 1:1 mixture of **44a** and **44'j** with catalyst **C1**. In this experiment, besides naphthalene **73a** and bicyclopropanes **74a** and **74e**, we also observed formation of **74f** and **74g**, which are the products of crossover cyclopropanation. This experiment was analyzed by HRMS (scheme 2.16).

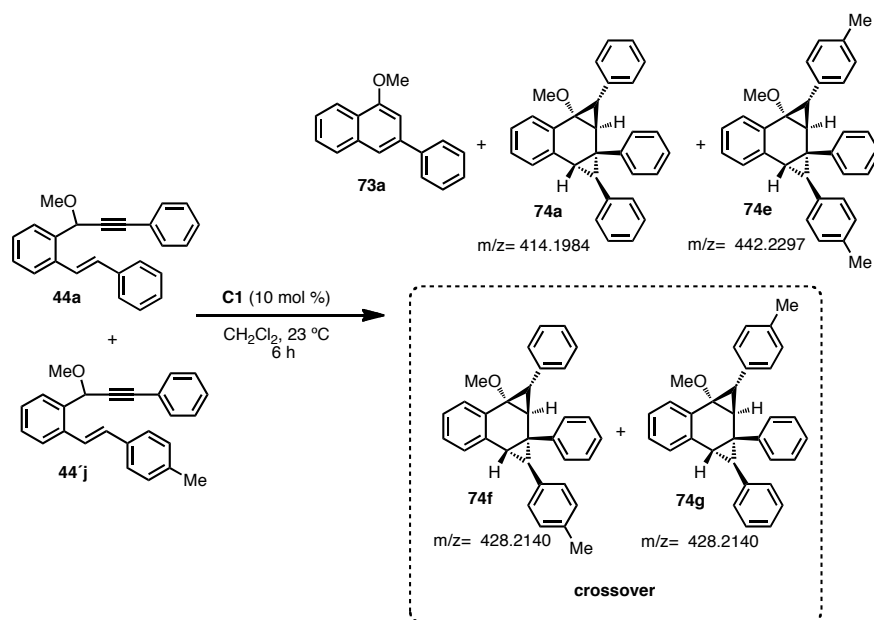

Scheme 2.16. Demonstration of the formation of free gold carbene **48** by crossover.

Furthermore, when the gold(I)-catalyzed annulation of **44a** was performed in the presence of *p*-methoxystyrene, cyclopropane **78** was obtained (6:1 *cis/trans*). As a

174 Solorio-Alvarado, C. R.; Echavarren, A. M. *J. Am. Chem. Soc.* **2010**, *132*, 11881-11883.

control, the cyclopropanation of *p*-methoxystyrene with phenyldiazomethane and catalyst **C1** also led to **78** (4.5:1 *cis/trans*) (Scheme 2.17).^{175,176,177}

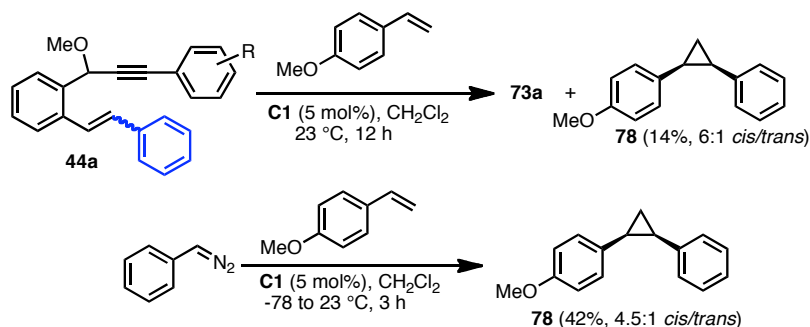

Scheme 2.17. Additional mechanistic studies to demonstrate the formation of free gold carbene **48**.

Final experimental support for this proposal was obtained by treatment of enol ether **79** with catalyst **C1** (CH_2Cl_2 , 23 °C, 1.5 h), which led cleanly to a mixture of 1-methoxy-3-phenylnaphthalene **73a** and biscyclopropane **74a** (Scheme 2.18).

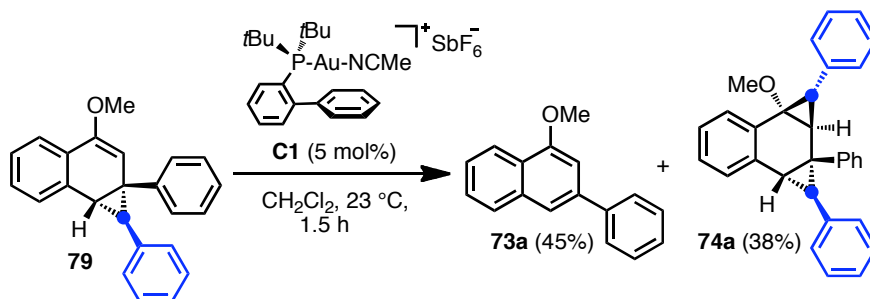

Scheme 2.18. The retro-cyclopropanation experiment of enol ether **79**.

Synthesis of enol ether **79** was carried out in 65% yield by treatment of ketone **69a** with trimethylorthoformate and *p*-TSA in methanol. An initial attempt to

175 Fructos, M. R.; Belderrain, T. R.; de Frémont, P.; Scott, N. M.; Nolan, S. P.; Diaz-Requejo, M. M.; Pérez, P. J. *Angew. Chem. Int. Ed.* **2005**, *44*, 5284-5288.

176 Lebel, H.; Marcoux, J.-F.; Molinaro, C.; Charette, A. B. *Chem. Rev.* **2003**, *103*, 977-1050.

177 Seits, W. J.; Hossain, M. M. *Tetrahedron Lett.* **1994**, *35*, 7561-7564.

synthesis **79** was carried out under basic conditions yielding cleanly a 5*H*-benzo[7]annulene **80**. This compound could be an interesting starting material for further functionalization in the synthesis of related compounds (Scheme 2.19).¹⁷⁸

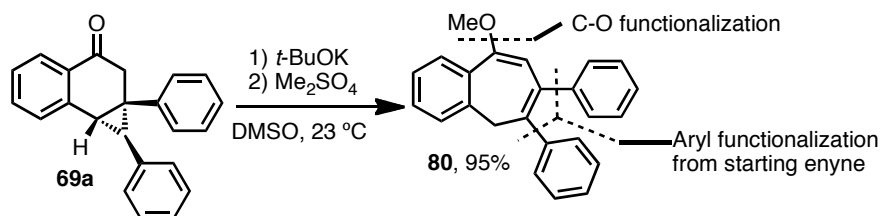

Scheme 2.19. Synthesis of the 5*H*-benzo[7]annulene **80**.

1,3-Disubstituted naphthalenes belong to a class of compounds not readily available by current methodologies such as electrophilic substitution or palladium-catalyzed cross-couplings. This protocol would allow to prepare analogues of this family of products by using enynes **44** as substrates, which are readily assembled in a modular form.¹⁷⁹

To illustrate the potential of this method, a formal synthesis of cytotoxic benzo[*c*]phenanthridine alkaloid macarpine^{180,181} was performed. In this way, we started the synthesis by iodination of *O*-methyl sesamol to give **81** in 94% yield. Songashira alkynylation proceed in nearly quantitative yield giving propargyl alcohol **82**, which upon Swern oxidation cleanly produce aldehyde **83** in excellent 90% yield. Metal-halogen exchange of **88** followed by 1,2-addition to **83** lead to the formation of the adduct **84** which was benzylated under standard conditions to produce the key enyne **85** in 96% yield.

178 a) Tobisu, M.; Shimasaki, T.; Chatani, N. *Angew. Chem. Int. Ed.* **2008**, *47*, 4866-4869. b)

Álvarez-Bercedo, P.; Martín, R. *J. Am. Chem. Soc.* **2010**, *132*, 17352-17353.

179 See experimental section for additional details.

180 Ishikawa, T.; Saito, T.; Ishii, H. *Tetrahedron* **1995**, *51*, 8447-8458.

181 Korivi, R. P.; Cheng, C.-H. *Chem. Eur. J.* **2010**, *16*, 282-287.

Gold(I)-catalyzed cyclization of **85** gave biaryl **86** in 79% yield, which upon hydrogenolysis provided naphthol **87**, an intermediate in the total synthesis of macarpine.

This constitutes a formal synthesis of this benzo[C]penantidine alkaloid (scheme 2.20).

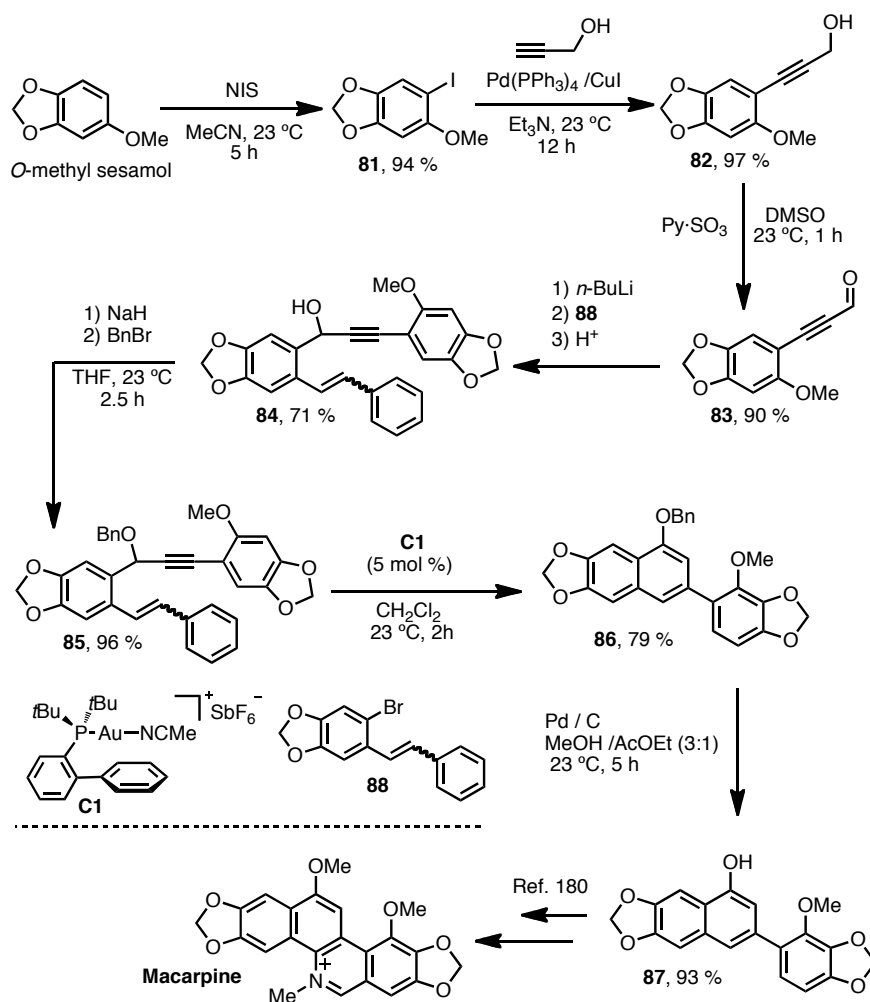

Scheme 2.20. Formal synthesis of macarpine by gold(I)-catalyzed retro-cyclopropanation of **85**.

As shown in Scheme 2.15, an electron-donating substituent different from OR at the benzyl-propargyl position could in principle be also used in the annulation. As

it turned out, enynes **89a-b** were ideal substrates to test this hypothesis. They were readily prepared in good yields from **44a** and the corresponding arenes in the presence of FeCl_3 .¹⁸² To our delight, annulation/fragmentation of **89a-b** in presence of catalyst **C1** deliver **90a-b** confirming the proposed mechanism of this reaction (Scheme 2.21).

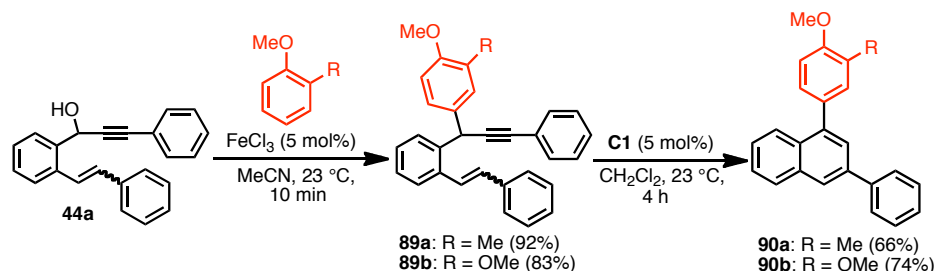

Scheme 2.21. Alternative propargylic substitution with electron-rich aryls, show the annulation/fragmentation process.

On the other hand, gold(I)-catalyzed reaction of enynes **45a-j** led to the formation of mono- and disubstituted naphthalenes **47a-j** (Scheme 2.22).

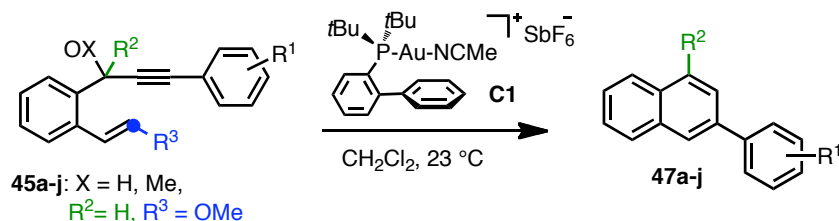

Scheme 2.22. Gold(I)-catalyzed annulation of 1,6-enynes **45** leading to the formation of naphthalenes **47**.

To study this transformation the enynes **45a-j** and **45'a-j** were synthesized following the synthetic route described in the Scheme 2.7 from aldehydes **60**, **62-68**, **94** and octynal (Scheme 2.23).

182 Zhan, Z.; Yu, J.; Liu, H.; Cui, Y.; Yang, R.; Yang, W.; Li, J. *J. Org. Chem.* **2006**, *71*, 8298-8301.

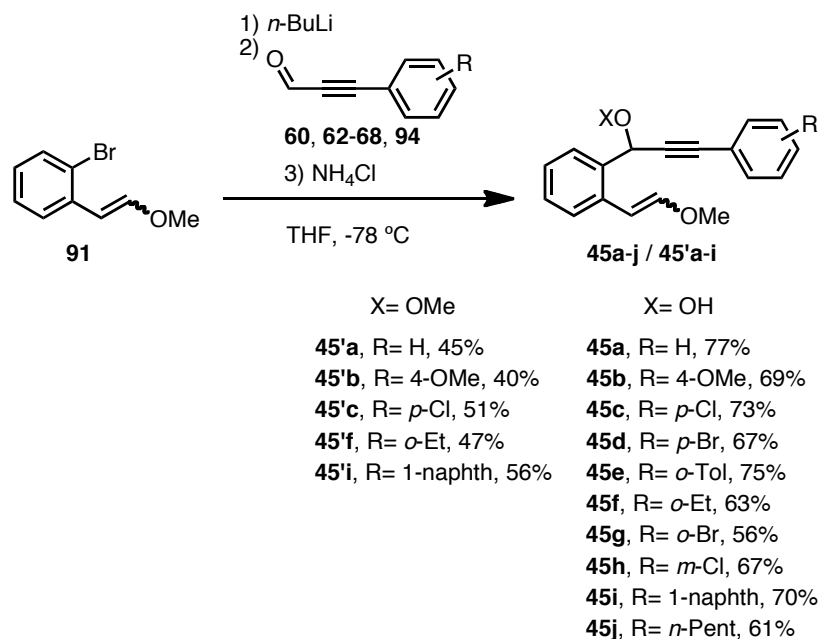

Scheme 2.23. Synthesis of enynes **45a-j**, and **45'a-i**.

Cyclization of enynes **45a-j** gave monosubstituted naphthalenes in good to excellent yields depending of propargylic substitution. The scope of this reaction was demonstrated with substrates containing electron-donating (**47b,e-f, i-j**), electron-attracting (**47c-d, g-h**) and electron-neutral groups (**47a**).

Comparing the skeleton of the starting enyne with final product was easy to identify that a fragmentation similar to **44a-j** took place for **45a-j** in this reaction. However in this case, additionally to the annulation/fragmentation sequence, a 1,5-migration of the propargylic alcohol or methyl ether to the carbon of the enol ether, is involved in this process.

Thus 1,6-Enynes **45a-j** containing propargyl alcohols or ethers, participated in this reaction cascade with catalyst **C1** at room temperature to furnish naphthalenes **47a-j** in good to excellent yields (Scheme 2.24).

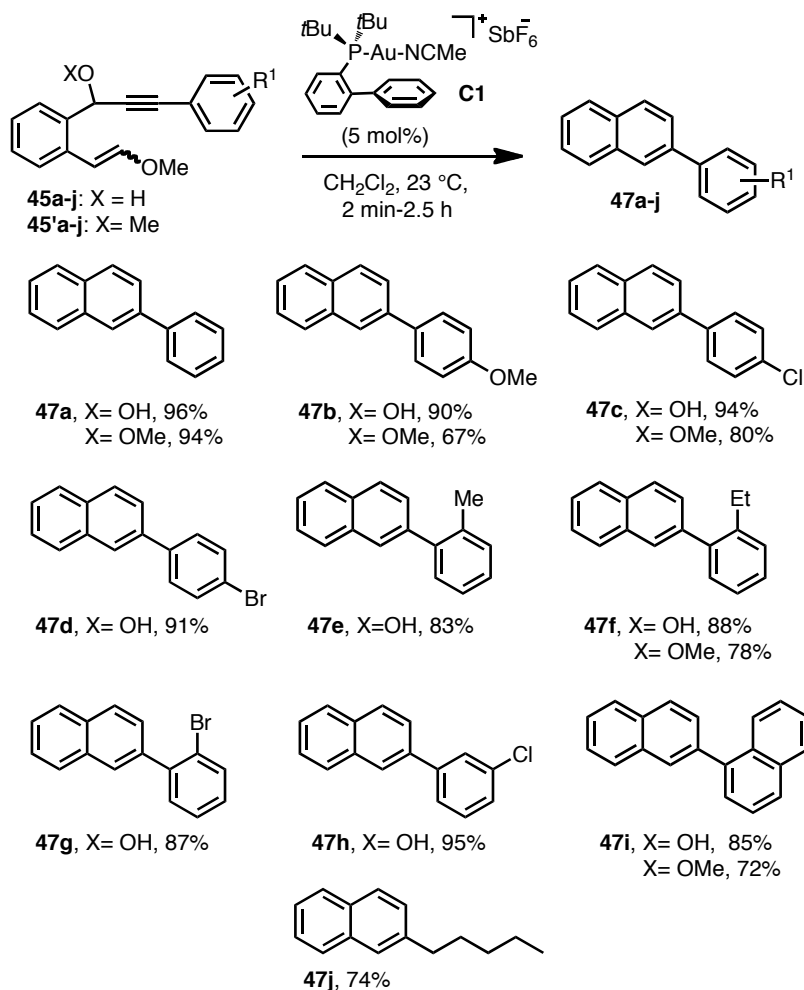

Scheme 2.24. Gold(I)-catalyzed synthesis of monosubstituted naphthalenes by annulation/1,5-migration/fragmentation.

This is a very general, mild and efficient annulation, which proceeds smoothly (2 min to 12 min) and with excellent yields for enynes containing propargyl alcohol. An alternative method with substrates bearing propargylic -OMe groups follows the same reaction pathway giving the same products although longer reaction times were required (2 h to 2.5 h) and slightly lower yields were obtained.

To expand the scope of this novel annulation, we thought that a propargylic aryl in the starting enyne, could lead to the formation of disubstituted naphthalenes.

Metal-halogen exchange of **91-91'** followed by addition to the corresponding ketones **95-96** gave propargylic alcohols which were too unstable in chromatography purification. Therefore, the crude products **97-99** were used as substrates for gold(I)-catalyzed reaction. Following this procedure, 1,3-disubstituted naphthalenes **100-102** were isolated in good yields (Scheme 2.25).

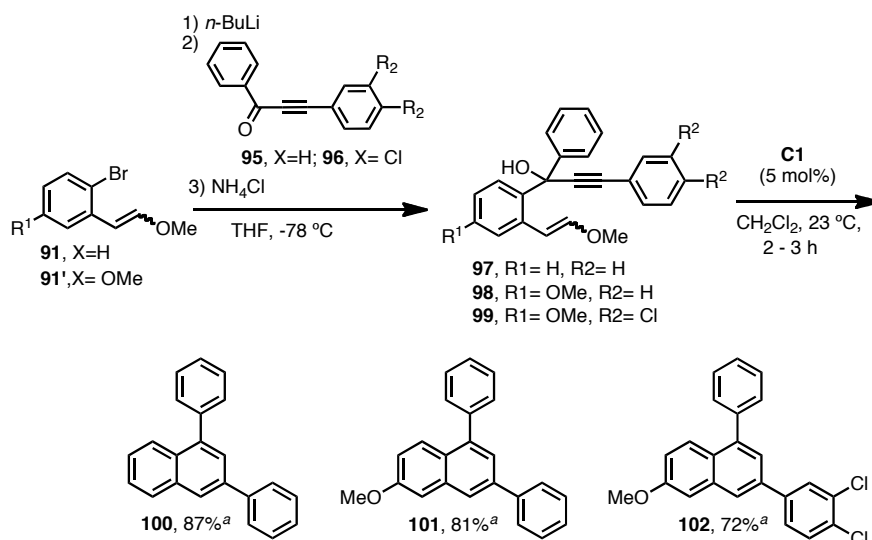

a) Isolated yields considering the ketones **95** and **96** as limiting reagent

Scheme 2.25. Synthesis of bi- and trisubstituted naphthalenes by gold(I)-catalyzed annulation/1,5-migration/fragmentation.

The mechanism of this reaction presumably proceeds by 6-*endo*-dig cyclization of **45** to form **103**, followed by intramolecular attack of the -OR group at the cyclopropane to form **104**. Fragmentative retro-Diels-Alder of intermediate **104**,¹⁸³ followed by protodeauration,¹⁸⁴ would give naphthalenes **47** (Scheme 2.26).

¹⁸³ A related cleavage was found as a minor pathway in the gold(I)-catalyzed synthesis of naphthalenes from 1,6-diyne-4-en-3-ols. Lian, J.-J.; Liu, R.-S. *Chem. Commun.* **2007**, 1337-1339.

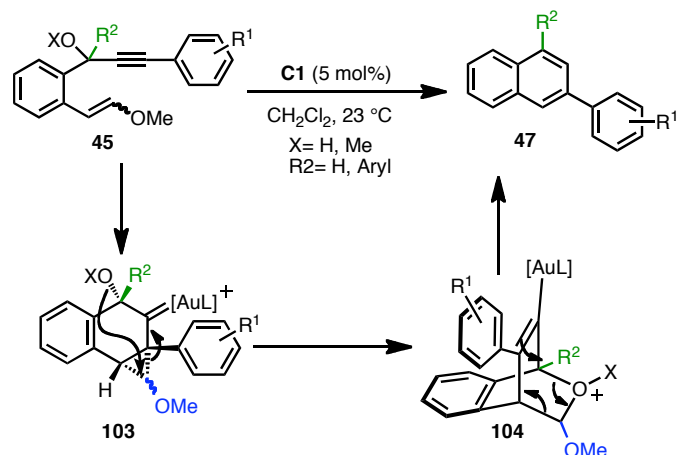

Scheme 2.26. Mechanism for the formation of naphthalenes by gold(I)-catalyzed annulation/1,5-migration/fragmentation.

Finally, some additional studies were carried out to further define the scope and limitations of the new annulations.

We first examined the cyclization with the starting enyne **117**. In this case, the *endo*-dig cycloisomerization took place with concomitant 1,5-alkyl ether migration to form **105**. The retro-cyclopropanation to form 1-methoxynaphthalene did not occur, instead the formation of known **105** was observed (Scheme 2.27).¹⁸⁵

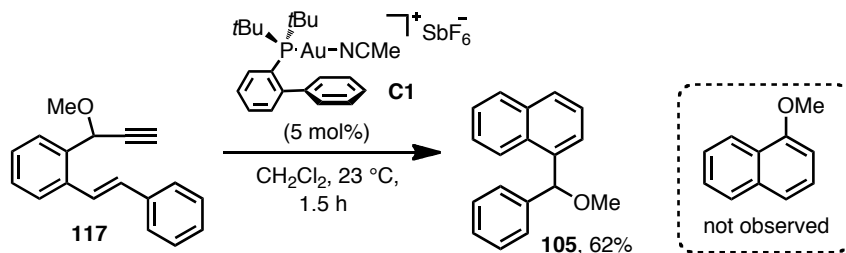

Scheme 2.27. Cycloisomerization/1,5-methoxy shift of enyne **117**.

184 Rothe, K. E.; Blum, S. A. *Organometallics* **2010**, *29*, 1712-1716.

185 Muller, P.; Nury, P.; Bernardinelli, G. *Eur. J. Org. Chem.* **2001**, *21*, 4137-4147.

Symmetric substrate **106** was synthesized by copper-catalyzed oxidative dimerization of **117**. Cyclization of **106** led to the formation of **107** and **108** in low yields even with 20 mol% of catalyst (Scheme 2.28).

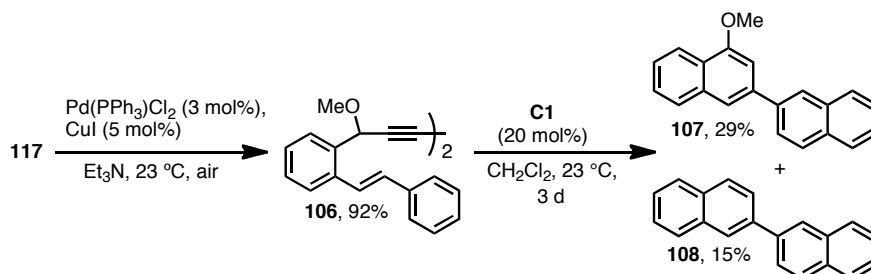

Scheme 2.28. Cyclization of the diene **106**.

We also decided to prepare a substrate with a trimethylsilyl group at the alkene. Thus reaction of *o*-bromostyrene with vinyltrimethylsilane in the presence of ruthenium hydride as catalyst afforded **109** following a known reaction.¹⁸⁶ Metal-halogen exchange and trapping with alkyne **60** led to **110** in 61% yield.

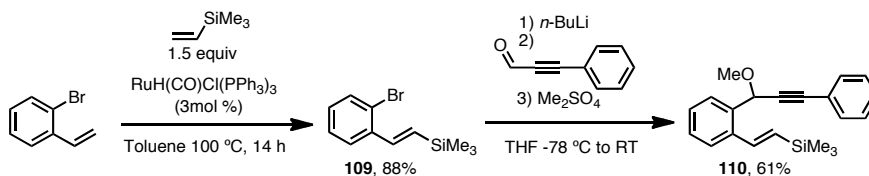

Scheme 2.29. Synthesis of **110**.

Treatment of **110** with cationic **C1** catalyst produced **111** in 68% yield via *endo*-dig cyclization. In this case, the reaction takes place without migration of the OMe group or fragmentation (Scheme 2.30).

¹⁸⁶ Pawluc, P.; Hreczycho, G.; Szudkowzka, J.; Kubicki, M.; Marciniak, B. *Org. Lett.* **2009**, *11*, 2230-2233.

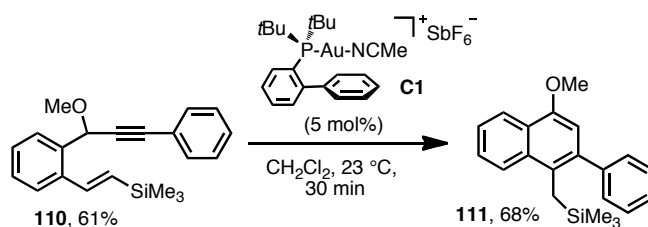

Scheme 2.30. Effect of the substitution in the terminal position of the alkyne in the cyclization of **111**.

Substitution with 2-indenyl group in the terminal position of the alkene was also examined. Synthesis of **113** started with cross-coupling between 2-formyl boronic acid and 2-bromoindene to form **112**. Addition of the lithium anion of pnehylacetylene in presence of $\text{GaCl}_3 \cdot 2\text{LiCl}$ yielded **113** in modest yield (Scheme 2.31).

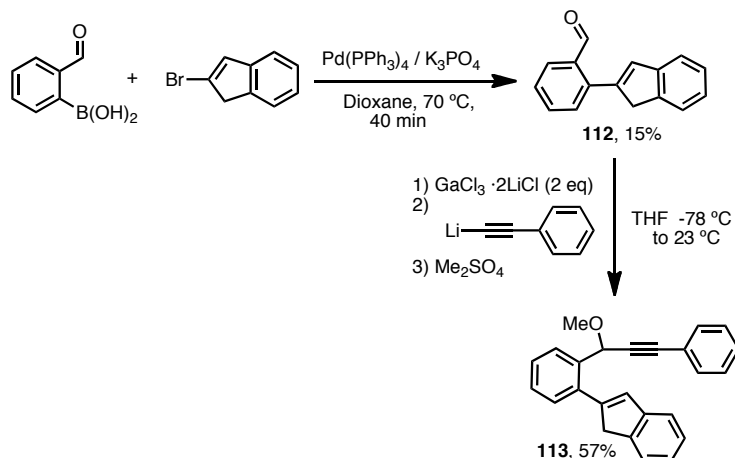

Scheme 2.31. Synthesis of enyne **113** bearing a 2-indenyl group in the terminal position of the alkene.

The treatment of **113** with cationic gold complex **C1** gave compounds **114** and **115** in 51% and 22% yield, respectively. The first one correspond the a cycloisomerization reaction, consistent with a 6-*endo*-dig attack of the olefin followed by 1,2-hydrogen shift and final protodeauration. The second product

(115) results from a loss of the methoxy group by a fragmentation and intramolecular trapping of the indenyl chain. However the mechanism for the formation of **115** is unclear at this moment (Scheme 2.32).

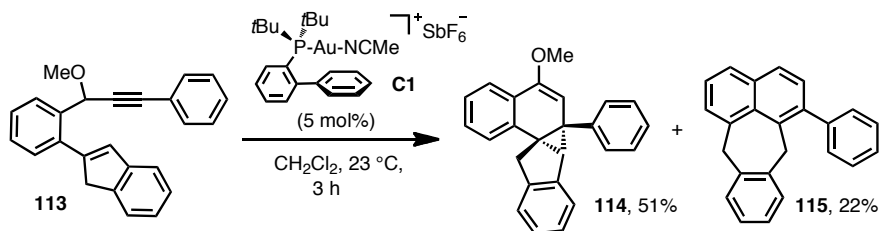

Scheme 2.32. Reactivity observed in the cyclization of 1,6-enynes with 2-indenyl group in terminal position of alkene.

The structure of **114** was determined by NMR studies and was confirmed by X-ray crystallography (Figure 2.1).

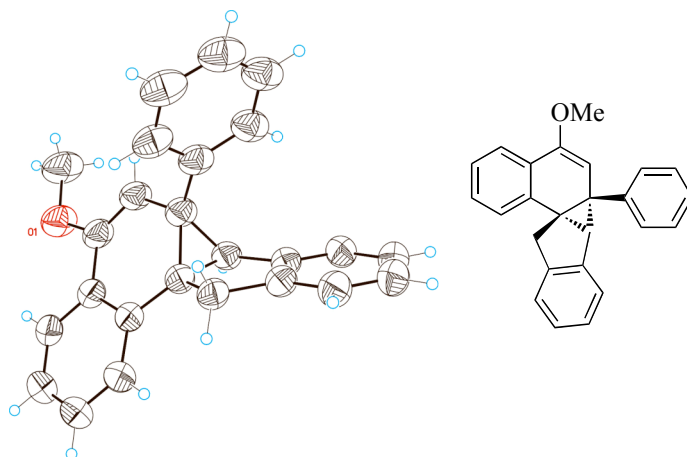

Figure 2.1. X-Ray of **114**.

The structure of **115** was determined by NMR. At room temperature the methylene hydrogens were observed as very broad resonances, which coalesced at around 100°C to give two broad singlets (Figure 2.2).

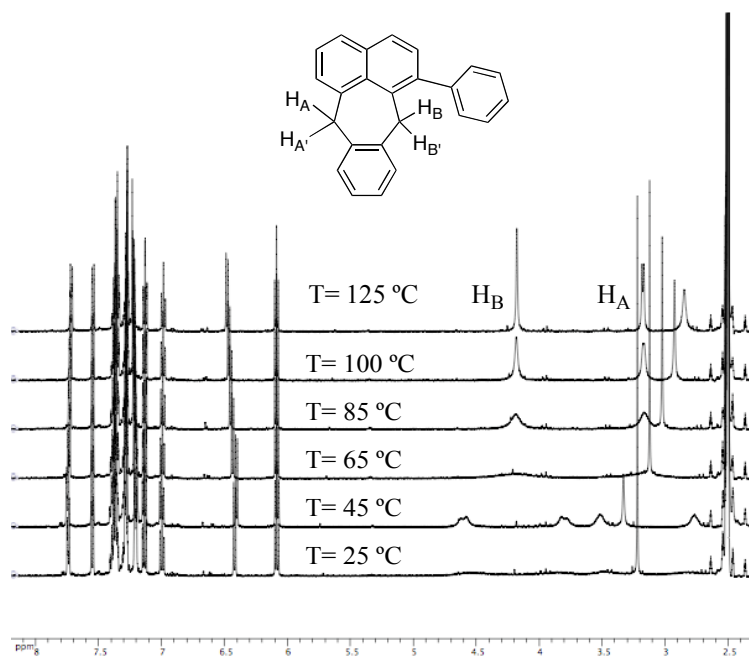
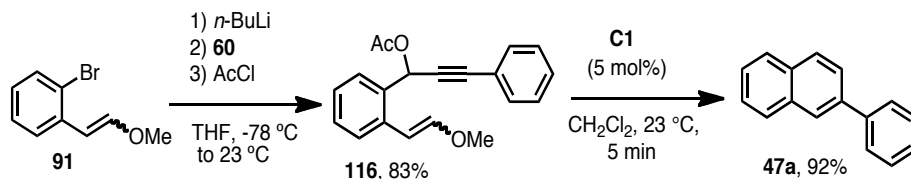

Figure 2.1. Confirmation of the determined structure of **115**. Spectra in DMSO.

Finally we synthesized compound **116** bearing a propargylic acetate from **91** and **60**. Reaction of **116** with gold complex **C1** led to compound **47a** following the mechanism shown in Scheme 2.26. Interestingly the 1,3-acetate migration to form the corresponding allene does not compete with the 1,5-acetate shift (Scheme 2.33).



Scheme 2.33. Reactivity observed in the cyclization of **116**.

Conclusions

- In summary, we have developed two new gold(I)-catalyzed annulations processes of 1,6-enynes for the synthesis of 1,3-disubstituted naphthalenes that proceed by fragmentation of the alkene.

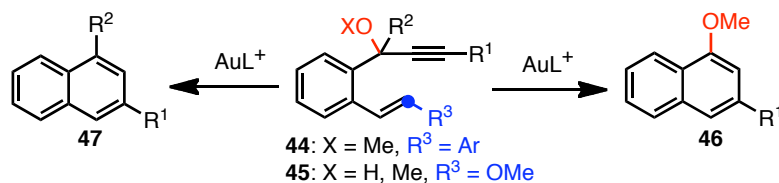

- One of these transformations involves the first example of a retro-cyclopropanation promoted by gold(I) which lead to the formation of free gold carbenes in solution. The generation of this species opens new possibilities to generate them in a safe manner and under mild conditions.

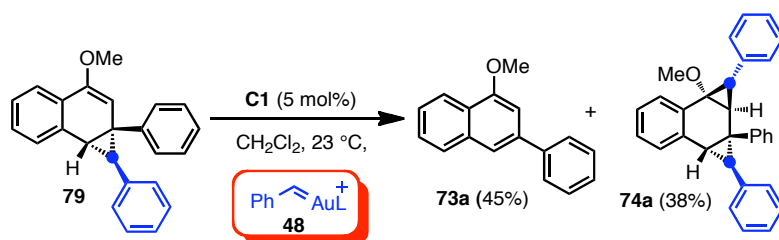

- The second annulation process lead to the formation of monosubstituted naphthalenes and proceed by a cascade of reaction starting with cycloisomerization/1,5-OR shift/fragmentative retro-Diels-Alder. This annulation is very fast for free propargylic alcohols and in general give excellent yields.

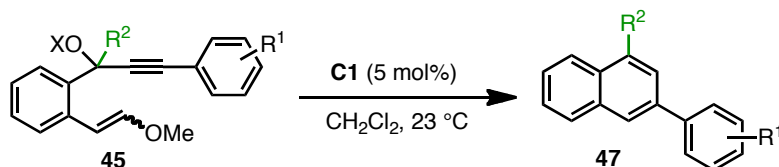

Experimental section

General methods.

All reactions were carried out under N₂ in solvents dried using a Solvent Purification System (SPS). Thin layer chromatography was carried out using TLC aluminum sheets with 0.2 mm of silica gel (Merck Gf234). Chromatographic purifications were carried out using flash grade silica gel (SDS Chromatogel 60 ACC, 40-60 μm). NMR spectra were recorded at 23 °C on a Bruker Avance 400 Ultrashield and Bruker Avance 500 Ultrashield apparatus. For some compounds PENDANT NMR spectra (Polarization Enhancement Nurtured During Attached Nucleus Testing) are provided instead of standard ¹³C NMR spectra. Mass spectra were recorded on a Waster LCT Premier Spectrometer (ESI and APCI) or on an Autoflex Broker Daltonics (MALDI and LDI). Melting points were determined using a Büchi melting point apparatus.

Gold catalyst, (acetonitrile)[(2-biphenyl)di-*tert*-butylphosphine]gold(I) hexafluoroantimonate (**C1**) was synthesized according to the literature procedure.¹

General Procedure A.

The corresponding phosphonium salt (1.5 equiv) was suspended in dry THF (0.5 M). The suspension was cooled to 0 °C with an ice bath, *t*-BuOK (1.65 equiv) was added portion wise. Immediately an intense red or orange color was observed. The mixture was stirred 40 min at this temperature, then corresponding aldehyde (1.0 equiv) was added in one portion. The ice bath was removed and the reaction was stirred at room temperature until the starting material had been consumed. The reaction was stopped by addition of sat. NH₄Cl solution. The aqueous phase was extracted with EtOAc, the combined organic extract was dried over MgSO₄, and the solvent was evaporated. The crude reaction mixture was purified by flash chromatography.

General Procedure B.

1-Bromo-2-styrylbenzene or 1-bromo-2-(2-methoxyvinyl)benzene derivatives (2 equiv) were dissolved in THF (0.1M). The solution was cooled to -78 °C before addition of *n*-BuLi (2.2 equiv). The mixture was stirred 40 min at this temperature, then corresponding aldehyde or ketone (1.0 equiv) was added in one portion and stirred additionally 20 min. The cooling bath was removed and the reaction was stopped by addition of sat. NH₄Cl solution. The aqueous phase was extracted with EtOAc, the combined organic extract was dried over MgSO₄, and the solvent was evaporated. The crude reaction mixture was purified by flash chromatography.

General Procedure C.

The corresponding propargyl alcohol (1 equiv) was dissolved in THF (0.3M). The solution was cooled to 0 °C with an ice bath before NaH (60% in mineral oil) (1.1 equiv) was added portion wise. The mixture was stirred at this temperature 10 min, then Me₂SO₄ (2 equiv) was added in one portion and stirred for additional 20 min. The ice bath was removed and the reaction was stopped by addition of sat. NH₄Cl solution. The aqueous phase was extracted with EtOAc, the combined organic extract was dried over MgSO₄, and the solvent was evaporated. The crude reaction mixture was purified by flash chromatography.

General Procedure D.

In a two necked dry round bottom flask equipped with magnetic stir bar, were placed Pd(PPh₃)₂Cl₂ (3 mol%) and CuI (8 mol%). The flask was evacuated and refilled with N₂ three times. The corresponding aryl iodide (1 equiv) and propargyl alcohol (1.1 equiv) were dissolved in triethylamine (0.03 M) and added to the flask with the catalyst. The mixture was stirred at room temperature until the starting material had been consumed. The reaction was stopped by addition of water and EtOAc. The organic phase was separated, washed several times with water and dried over MgSO₄. The solvent was evaporated to get the crude reaction mixture, which was purified by flash chromatography.

General Procedure E.

The corresponding propargyl alcohol (1 equiv) was dissolved in DMSO (0.1M). Triethylamine (3 equiv) and complex $\text{py}\cdot\text{SO}_3$ (3 equiv) were added and the mixture was stirred at room temperature until the starting material had been consumed. The reaction was stopped by addition of water and EtOAc. The organic phase was separated, washed several times with water and dried over MgSO_4 . The solvent was evaporated to get the crude reaction mixture, which was purified by flash chromatography.

General Procedure F.

In a dry vial equipped with magnetic stir bar was dissolved the corresponding enyne in CH_2Cl_2 (0.3 M) and complex **C1** (5 mol%) was added. An intense red, violet or dark orange color was observed immediately. The mixture was stirred at room temperature until the starting material had been consumed. The reaction was stopped by addition of three drops of triethylamine. The solvent was evaporated to get the crude reaction mixture, which was purified by flash chromatography.

Synthesis of aldehydes **65**, **67-68**.

1-Chloro-3-iodobenzene, 1-bromo-2-iodobenzene and 1-ethyl-2-iodobenzene are commercially available reagents and were used without further purifications.

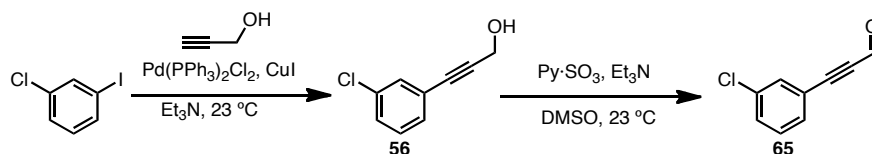

3-(3-Chlorophenyl)propionaldehyde (65). This compound was synthesized in 83% yield by oxidation of propargylic alcohol **56** according to general procedure E.

^1H NMR (400 MHz, CDCl_3) δ 9.48 (s, 1H), 7.65 (dd, $J = 7.6, 1.4$ Hz, 1H), 7.46 (dt, $J = 8.0, 2.0$ Hz, 1H), 7.42 (dt, $J = 8.0, 2.0$ Hz, 1H), 7.30 (dt, $J = 8.0,$

2.0 Hz, 1H).

^{13}C NMR (100 MHz, CDCl_3) δ 176.7(CHO), 140.4 (C), 137.8 (C), 135.2 (CH), 132.4 (CH), 129.9 (CH), 127.0 (CH), 92.3 (C), 91.1 (C). HRMS-APCI calcd for $\text{C}_9\text{H}_6\text{ClO}$ (M+H) $^+$: 165.0107; found: 165.0101.

3-(3-Chlorophenyl)prop-2-yn-1-ol (**56**). This compound was prepared in 91% yield as a red oil, according to general procedure **D**.

^1H NMR (400 MHz, CDCl_3) δ 7.49 (dd, $J = 7.8, 1.2$ Hz, 1H), 7.41-7.38 (m, 1H), 7.27 (dt, $J = 8.0, 1.6$ Hz, 1H), 7.21 (dt, $J = 8.0, 1.6$ Hz, 1H), 4.55 (d, $J = 6.0$ Hz, 2H), 1.73 (t, $J = 6.0$ Hz, 1H).

^{13}C NMR (100 MHz, CDCl_3) δ 136.1 (C), 133.7 (CH), 129.7 (CH), 129.5 (CH), 126.7 (CH), 122.7 (C), 92.6 (C), 82.6 (C), 51.9 (CH_2).

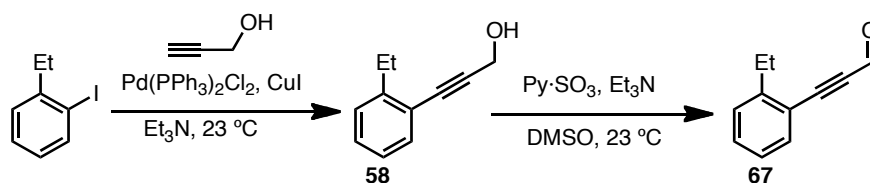

3-(2-Ethylphenyl)propionaldehyde (**67**). This compound was synthesized in 80% yield by oxidation of propargylic alcohol **58** according to general procedure **E**.

^1H NMR (400 MHz, CDCl_3) δ 9.47 (s, 1H), 7.57 (dd, $J = 7.6, 1.2$ Hz, 1H), 7.42 (dt, $J = 8.0, 2.0$ Hz, 1H), 7.31-7.27 (m, 1H), 7.22 (dt, $J = 8.0, 2.0$ Hz, 1H), 2.80 (q, $J = 7.6$ Hz, 2H), 1.24 (t, $J = 7.6$ Hz, 3H).

^{13}C NMR (100 MHz, CDCl_3) 176.9(CHO), 148.9 (C), 134.3 (CH), 131.8 (CH), 128.6 (CH), 126.2 (CH), 118.7 (C), 94.4 (C), 92.1 (C), 27.8(CH_2), 15.2(CH_3). HRMS-APCI calcd for $\text{C}_{11}\text{H}_{11}\text{O}$ (M+H) $^+$: 159.0818; found: 159.0810.

3-(2-Ethylphenyl)prop-2-yn-1-ol (**58**). This compound was prepared in 96% yield as a brown oil, according to general procedure **D**.

^1H NMR (400 MHz, CDCl_3) δ 7.41 (dd, $J = 7.6, 1.2$ Hz, 1H), 7.27 (dt, $J = 8.0, 2.0$ Hz, 1H), 7.23-7.19 (m, 1H), 7.14 (dt, $J = 8.0, 2.0$ Hz, 1H), 5.54 (d, $J = 6.4$ Hz, 2H), 2.80 (q, $J = 7.6$ Hz, 2H), 1.61 (t, 6.4 Hz, 1H), 1.24 (t, $J = 7.6$ Hz,

3H).

^{13}C NMR (100 MHz, CDCl_3) 146.52 (C), 132.62 (CH), 128.96 (CH), 128.14 (CH), 125.81 (CH), 121.81 (C), 90.74 (C), 84.65 (C), 52.04 (CH_2), 27.78 (CH_2), 15.01 (CH_3).

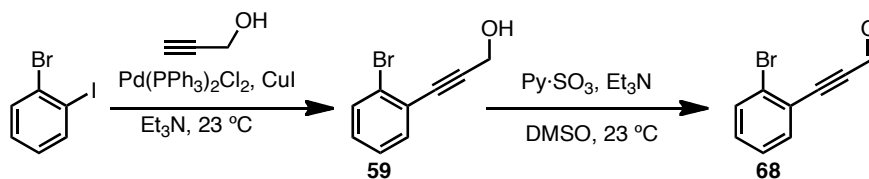

3-(2-Bromophenyl)prop-2-ynal (68). This compound was synthesized in 74% yield by oxidation of propargylic alcohol **59** according to general procedure **E**.

^1H NMR (400 MHz, CDCl_3) δ 9.49 (s, 1H), 7.68-7.64 (m, 1H), 7.63-7.60 (m, 1H), 7.34 (quint, $J = 3.6$ Hz, 2H).

^{13}C NMR (100 MHz, CDCl_3) δ 176.7(CHO), 135.3 (CH), 133.1 (CH), 132.5 (CH), 127.6 (CH), 127.1 (C), 122.2 (C), 92.8 (C), 91.6 (C). HRMS-APCI calcd for $\text{C}_9\text{H}_6\text{BrO}$ ($\text{M}+\text{H}$) $^+$: 208.9602; found: 208.9594.

3-(2-Bromophenyl)prop-2-yn-1-ol (59). This compound was prepared in 87% yield as an amber oil, according to general procedure **D**.

^1H NMR (400 MHz, CDCl_3) δ 7.59 (dd, $J = 8.0, 1.2$ Hz, 1H), 7.48 (dd, $J = 7.6, 2.0$ Hz, 1H), 7.27 (dt, $J = 8.0, 1.6$ Hz, 1H), 7.18 (dt, $J = 8.0, 1.6$ Hz, 1H), 4.56 (d, $J = 6.0$ Hz, 2H), 1.80 (t, $J = 6.0$ Hz, 1H).

^{13}C NMR (100 MHz, CDCl_3) δ 133.74 (CH), 132.58 (CH), 129.85 (CH), 127.2 (CH), 125.6 (C), 124.8 (C), 92.1 (C), 84.3 (C), 51.82 (CH_2).

Enynes 44'a-i. Scheme 2.

1-Bromo-2-styrylbenzene **49**,² 3-phenylprop-2-yn-1-ol **51**,³ 3-(*p*-tolyl)prop-2-yn-1-ol **52**,⁴ 3-(4-methoxyphenyl)prop-2-yn-1-ol **53**,⁵ 3-(4-chlorophenyl)prop-2-yn-1-ol **54**,⁶ 3-(4-bromophenyl)prop-2-yn-1-ol **55**,⁷ 3-(*o*-tolyl)prop-2-yn-1-ol **57**,⁸ 3-(2-ethylphenyl)prop-2-yn-1-ol **58**,⁹ 3-(naphthalen-1-yl)prop-2-yn-1-ol **93**,¹⁰ 3-(*p*-

tolyl)propionaldehyde **61**,¹¹ 3-(4-methoxyphenyl)propionaldehyde **62**,¹² 3-(4-chlorophenyl)propionaldehyde **63**,¹³ 3-(4-bromophenyl)propionaldehyde **64**,¹⁴ and 3-(*o*-tolyl)propionaldehyde **66**,⁸ 3-(naphthalen-1-yl)propionaldehyde **94**,¹⁵ were synthesized according to literature procedures.

3-Phenyl-1-(2-styrylphenyl)prop-2-yn-1-ol (**44'a**).

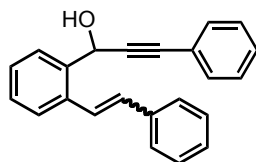

This compound was prepared according to the general procedure **B** starting from 1-bromo-2-styrylbenzene **49** and 3-phenylpropionaldehyde **60**. Yellow oil (75%, 5:1 *E/Z*). Signals for major isomer (*E*).

¹H NMR (400 MHz, CDCl₃) δ 7.79 (d, *J* = 7.6 Hz, 1H), 7.40-7.36 (m, 3H), 7.31-7.26 (m, 4H), 7.22-7.18 (m, 2H), 7.16-7.09 (m, 4H), 6.93 (d, *J* = 12.0 Hz, 1H), 6.74 (d, *J* = 12.0 Hz, 1H), 5.87 (d, *J* = 5.2 Hz, 1H), 2.21 (d, *J* = 5.2 Hz, 1H).

¹³C NMR (100 MHz, CDCl₃) δ 138.5 (CH), 136.57 (C), 136.56 (C), 132.2 (CH), 131.9 (CH), 129.9 (CH), 129.4 (CH), 128.7 (C), 128.66 (C), 128.4 (CH), 128.38 (CH), 128.16 (CH), 128.0 (CH), 127.6 (CH), 127.2 (CH), 126.9 (CH), 88.7 (C), 86.7 (C), 63.3 (CH). HRMS-ESI calcd for C₂₃H₁₈O (*M*+Na)⁺: 333.1255; found: 333.1247.

1-(2-Styrylphenyl)-3-*p*-tolylprop-2-yn-1-ol (**44'b**).

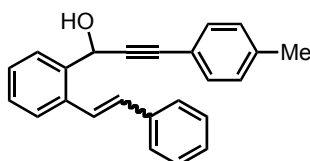

This compound was prepared according to the general procedure **B** starting from 1-bromo-2-styrylbenzene **49** and 3-(*p*-tolyl)propionaldehyde **61**. Brown dark oil (71%, 5:1 *E/Z*). Signals for major isomer (*E*).

^1H NMR (400 MHz, CDCl_3) δ 7.79 (d, $J = 7.6$ Hz, 1H), 7.33 (dt, $J = 6.8$, 2.0 Hz, 2H), 7.28 (d, $J = 8.4$ Hz, 2H), 7.18-7.06 (m, 7H), 7.07 (d, $J = 8.4$ Hz, 2H), 6.92 (d, $J = 12.0$ Hz, 1H), 6.72 (d, $J = 12.0$ Hz, 1H), 5.85 (bs, 1H), 2.32 (s, 3H).

^{13}C NMR (100 MHz, CDCl_3) δ 138.8 (C), 136.6 (C), 132.2 (CH), 131.8 (CH), 129.9 (CH), 129.4 (CH), 129.2 (CH), 128.8 (C), 128.7 (C), 128.4 (CH), 128.2 (CH), 128.0 (CH), 127.5 (CH), 127.2 (CH), 124.6 (C), 119.6 (CH), 88.1 (C), 86.9 (C), 63.4 (CH), 21.7(CH₃). HRMS-ESI calcd for $\text{C}_{24}\text{H}_{20}\text{O}$ ($M+\text{Na}$)⁺: 347.1418; found: 347.1412.

(E)-3-(4-Methoxyphenyl)-1-(2-styrylphenyl)prop-2-yn-1-ol (44'c).

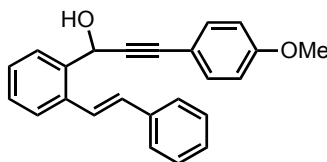

This compound was prepared according to the general procedure **B** starting from 1-bromo-2-styrylbenzene **49** and 3-(4-methoxyphenyl)propionaldehyde **62**. Yellow oil (70%).

^1H NMR (400 MHz, CDCl_3) δ 7.79 (dd, $J = 8.0$, 1.2 Hz, 1H), 7.38-7.31 (m, 2H), 7.33 (d, $J = 8.8$ Hz, 2H), 7.23-7.09 (m, 6H), 6.93 (d, $J = 12.4$ Hz, 1H), 6.80 (d, $J = 8.8$ Hz, 2H), 6.73 (d, $J = 12.4$ Hz, 1H), 6.86 (d, $J = 5.6$ Hz, 1H), 3.79 (s, 3H), 2.18 (d, $J = 5.6$ Hz, 1H).

^{13}C NMR (100 MHz, CDCl_3) δ 159.9 (C), 138.7 (C), 136.6 (C), 136.5 (C), 133.4 (CH), 132.1 (CH), 129.9 (CH), 129.4 (CH), 128.6 (CH), 128.4 (CH), 128.2 (CH), 128.0 (CH), 127.5 (CH), 127.2 (CH), 114.8 (C), 114.0 (CH), 87.4 (C), 86.7 (C), 63.4 (CH), 55.4(CH₃). HRMS-ESI calcd for $\text{C}_{24}\text{H}_{20}\text{O}_2$ ($M+\text{Na}$)⁺: 363.1378; found: 363.1361.

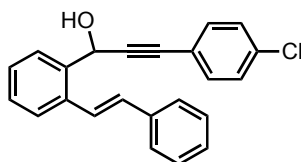
(E)-3-(4-Chlorophenyl)-1-(2-styrylphenyl)prop-2-yn-1-ol (44'd).

This compound was prepared according to the general procedure **B** starting from 1-bromo-2-styrylbenzene **49** and 3-(4-chlorophenyl)propiolaldehyde **63**. Brown oil (63%).

^1H NMR (400 MHz, CDCl_3) δ 7.76 (d, $J = 7.6$ Hz, 1H), 7.37-7.32 (m, 2H), 7.30-7.18 (m, 6H), 7.15-7.08 (m, 4H), 6.90 (d, $J = 12.0$ Hz, 1H), 6.74 (d, $J = 12.0$ Hz, 1H), 5.85 (bs, 1H), 2.20 (bs, 1H).

^{13}C NMR (100 MHz, CDCl_3) δ 138.3 (C), 136.5 (CH), 134.7 (C), 133.5 (C), 133.1 (CH), 132.3 (CH), 130.2 (C), 129.9 (CH), 129.3 (CH), 129.1 (CH), 128.7 (CH), 128.4 (CH), 128.1 (CH), 127.6 (CH), 127.1 (CH), 121.2 (C), 89.8 (C), 85.5 (C), 63.2 (CH). HRMS-ESI calcd for $\text{C}_{23}\text{H}_{17}\text{ClO}$ ($M+\text{Na}$) $^+$: 367.0853; found: 367.0866.

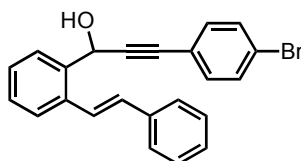
(E)-3-(4-Bromophenyl)-1-(2-styrylphenyl)prop-2-yn-1-ol (44'e).

This compound was prepared according to the general procedure **B** starting from 1-bromo-2-styrylbenzene **49** and 3-(4-bromophenyl)propiolaldehyde **64**. Yellow oil (66%).

^1H NMR (400 MHz, CDCl_3) δ 7.76 (dd, $J = 8.0, 1.2$ Hz, 1H), 7.40 (d, $J = 8.4$ Hz, 2H), 7.35 (dt, $J = 7.6, 1.6$ Hz, 1H), 7.31-7.24 (m, 2H), 7.22 (d, $J = 8.4$ Hz, 2H), 7.21-7.18 (m, 1H), 7.15-7.08 (m, 4H), 6.90 (d, $J = 12.0$ Hz, 1H), 6.73 (d, $J = 12.0$ Hz, 1H), 5.85 (bs, 1H), 2.22 (bs, 1H).

^{13}C NMR (100 MHz, CDCl_3) δ 138.3 (C), 136.56 (C), 136.52 (C), 133.3 (CH), 132.3 (CH), 131.7 (CH), 129.9 (CH), 129.4 (CH), 128.8 (CH), 128.4 (CH), 128.1 (CH), 128.0 (CH), 127.6 (CH), 127.1 (CH), 122.9 (C), 121.6 (C), 89.9 (C), 85.6 (C), 63.3 (CH). HRMS-ESI calcd for $\text{C}_{23}\text{H}_{17}\text{BrO}$ ($M+\text{Na}$) $^+$: 411.0358; found: 411.0358.

(E)-3-(3-Chlorophenyl)-1-(2-styrylphenyl)prop-2-yn-1-ol (44'f).

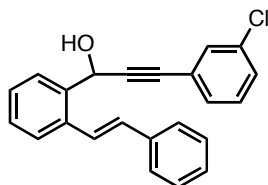

This compound was prepared according to the general procedure **B** starting from 1-bromo-2-styrylbenzene **49** and 3-(3-chlorophenyl)propionaldehyde **65**. Colorless oil (61%).

^1H NMR (400 MHz, CDCl_3) δ 7.86 (d, $J = 7.6$ Hz, 1H), 7.43-7.32 (m, 3H), 7.27-7.17 (m, 6H), 7.15-7.09 (m, 3H), 6.96 (d, $J = 12.4$ Hz, 1H), 6.74 (d, $J = 12.4$ Hz, 1H), 5.92 (bs, 1H), 2.24 (bs, 1H).

^{13}C NMR (100 MHz, CDCl_3) δ 138.2 (C), 136.6 (C), 136.56 (CH), 133.7 (CH), 132.3 (CH), 129.9 (CH), 129.7 (CH), 129.4 (CH), 128.9 (CH), 128.8 (CH), 128.4 (CH), 128.1 (CH), 128.0 (CH), 127.5 (CH), 127.4 (CH), 126.5 (CH), 125.7 (C), 122.6 (C), 93.9 (C), 83.5 (C), 63.4 (CH). HRMS-ESI calcd for $\text{C}_{23}\text{H}_{17}\text{ClO}$ ($M+\text{Na}$) $^+$: 367.0853; found: 367.0858.

(E)-1-(2-Styrylphenyl)-3-*o*-tolylprop-2-yn-1-ol (44'g).

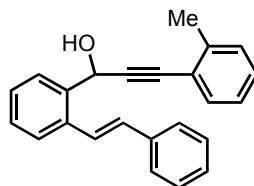

This compound was prepared according to the general procedure **B** starting from 1-bromo-2-styrylbenzene **49** and 3-(*o*-tolyl)propionaldehyde **66**. Yellow oil (56%).

^1H NMR (400 MHz, CDCl_3) δ 7.82 (d, $J = 7.6$ Hz, 1H), 7.37 (t, $J = 7.6$ Hz, 1H), 7.36 (s, 1H), 7.20 (t, $J = 8.0$ Hz, 5H), 7.15-7.09 (m, 5H), 6.94 (d, $J = 12.0$ Hz, 1H), 6.74 (d, $J = 12.0$ Hz, 1H), 5.91 (bs, 1H), 2.40 (s, 3H), 1.54 (bs, 1H).

^{13}C NMR (100 MHz, CDCl_3) δ 140.5 (C), 138.7 (C), 136.5 (C), 136.4 (C), 132.3 (CH), 132.2 (CH), 129.9 (CH), 129.6 (CH), 129.3 (CH), 128.9 (C), 128.8 (CH), 128.4 (CH), 128.1 (CH), 128.0 (CH), 127.5 (CH), 127.2 (CH), 126.9 (CH), 125.6 (CH), 92.7 (C), 85.7 (C), 63.4 (CH), 20.9 (CH_3). HRMS-ESI calcd for $\text{C}_{24}\text{H}_{20}\text{O}$ ($M+\text{Na}$) $^+$: 347.1417; found: 347.1412.

(*E*)-3-(2-Ethylphenyl)-1-(2-styrylphenyl)prop-2-yn-1-ol (44'h).

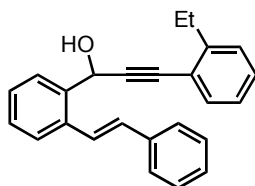

This compound was prepared according to the general procedure **B** starting from 1-bromo-2-styrylbenzene **49** and 3-(2-ethylphenyl)propionaldehyde **67**. Yellow oil (49%).

^1H NMR (400 MHz, CDCl_3) δ 7.81 (d, $J = 7.4$ Hz, 1H), 7.37 (d, $J = 7.2$ Hz, 1H), 7.34 (t, $J = 7.6$ Hz, 1H), 7.22-7.18 (m, 4H), 7.16-7.08 (m, 6H), 6.94 (d, $J = 12.2$ Hz, 1H), 6.73 (d, $J = 12.2$ Hz, 1H), 5.92 (d, $J = 5.6$ Hz, 1H), 2.77 (q, $J = 7.6$ Hz, 2H), 2.19 (d, $J = 5.6$ Hz, 1H), 1.20 (t, $J = 7.6$ Hz, 3H).

^{13}C NMR (100 MHz, CDCl_3) δ 146.6 (C), 138.7 (C), 136.6 (C), 136.5 (C), 132.6 (CH), 132.5 (CH), 129.9 (CH), 129.4 (CH), 128.9 (CH), 128.7 (CH), 128.4 (CH), 128.1 (CH), 128.09 (CH), 128.04 (CH), 127.6 (CH), 127.2 (CH), 125.8 (CH), 121.8 (C), 92.2 (C), 85.6 (C), 63.4 (CH), 27.9 (CH_2), 15.0 (CH_3). HRMS-ESI calcd for $\text{C}_{25}\text{H}_{22}\text{O}$ ($M+\text{Na}$) $^+$: 361.1577; found: 361.1568.

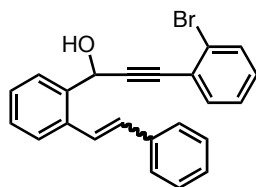
3-(2-Bromophenyl)-1-(2-styrylphenyl)prop-2-yn-1-ol (44'i).

This compound was prepared according to the general procedure **B** starting from 1-bromo-2-styrylbenzene **49** and 3-(2-bromophenyl)propionaldehyde **68**. Brown oil (54%, 2:1 *E/Z*).

^1H NMR (400 MHz, CDCl_3) δ 7.88 (d, $J = 7.6$ Hz, 1H, *Z*), 7.80 (d, $J = 7.6$ Hz, 1H, *E*), 7.61-7.55 (m, 1H, *E* + 1H, *Z*), 7.42-7.32 (m, 3H, *E* + 3H, *Z*), 7.31-7.27 (m, 2H, *E* + 2H, *Z*), 7.23-7.18 (m, 2H, *E* + 3H, *Z*), 7.16-7.09 (m, 4H, *E* + 4H, *Z*), 6.97 (d, $J = 7.6$ Hz, 1H, *Z*), 6.93 (d, $J = 12.0$ Hz, 1H, *E*), 6.74 (d, $J = 12.0$ Hz, 1H, *E*), 5.92 (bs, 1H, *Z*), 5.87 (bs, 1H, *E*).

^{13}C NMR (100 MHz, CDCl_3) δ 138.5 (C, *E*), 138.2 (C, *Z*), 136.6 (C, *E*), 136.57 (CH, *E+Z*), 133.8 (C, *Z*), 133.7 (C, *E*), 133.2 (C, *Z*), 132.6 (C, *Z*), 132.56 (C, *E*), 132.3 (C, *Z*), 132.2 (C, *E*), 131.9 (CH, *E+Z*), 131.89 (CH \times 2, *E+Z*), 129.9 (CH, *E+Z*), 129.8 (CH, *E+Z*), 129.4 (CH \times 2, *E+Z*), 128.88 (CH, *Z*), 128.8 (CH, *Z*), 128.7 (CH, *E*), 128.6 (CH, *E*), 128.5 (CH \times 2, *E+Z*), 128.4 (CH \times 2, *E+Z*), 128.2 (CH, *E+Z*), 128.0 (CH, *E+Z*), 127.6 (CH, *E*), 127.4 (CH, *Z*), 127.2 (CH, *E*), 126.7 (CH, *Z*), 125.8 (CH, *E+Z*), 124.9 (CH, *E+Z*), 124.7 (CH, *E+Z*), 122.7 (CH, *E+Z*), 93.5 (C, *Z*), 88.8 (C, *E*), 86.7 (C, *E*), 85.3 (C, *Z*), 63.4 (CH, *Z*), 63.3 (CH, *E*). HRMS-ESI calcd for $\text{C}_{23}\text{H}_{17}\text{BrO}$ ($M+\text{Na}$) $^+$: 411.0358; found: 411.0358.

Ketones 69a-i. Scheme 2.10.

(1*R*^{*},1*aR*^{*},7*bS*^{*})-1*a*,2-Dihydro-1,1*a*-diphenyl-1*H*-cyclopropa[*a*]naphthalen-3(7*bH*)-one (69a).

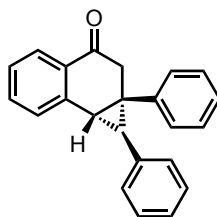

This compound was prepared by cyclization of enyne **44'a**, according to the general procedure **F** in 69% yield as a white solid. mp 120-122 °C.

^1H NMR (400 MHz, CDCl_3) δ 7.61-7.57 (m, 2H), 7.53 (d, $J = 8.4$ Hz, 3H), 7.41 (t, $J = 7.2$ Hz, 2H), 7.30 (t, $J = 7.4$ Hz, 1H), 7.22 (t, $J = 7.4$ Hz, 1H), 7.12-7.05 (m, 3H), 6.85 (d, $J = 6.8$ Hz, 2H), 3.28 (d, $J = 18.4$ Hz, 1H), 3.04 (s, 2H), 2.93 (d, $J = 18.4$ Hz, 1H).

^{13}C NMR (100 MHz, CDCl_3) δ 194.6 (CO), 145.3 (C), 141.6 (C), 133.6 (CH), 133.0 (C), 132.4 (CH), 131.6 (C), 129.4 (CH), 129.1 (CH), 128.4 (CH), 128.1 (CH), 127.2 (CH), 127.1 (CH), 126.4 (CH), 126.2 (CH), 42.6 (CH_2), 35.3 (CH), 30.7 (C), 28.7 (CH). HRMS-ESI calcd for $\text{C}_{23}\text{H}_{18}\text{O}$ ($M+\text{Na}$) $^+$: 333.1255; found: 333.1243.

(1R*,1aR*,7bS*)-1a,2-Dihydro-1-phenyl-1a-p-tolyl-1H-cyclopropa[a]naphthalen-3(7bH)-one (69b).

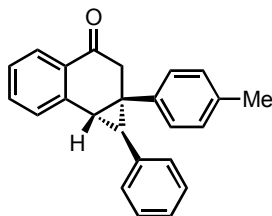

This compound was prepared by cyclization of enyne **44'b**, according to the general procedure **F** in 74% yield as a yellow oil.

^1H NMR (400 MHz, CDCl_3) δ 7.60 (t, $J = 4.0$ Hz, 2H), 7.55 (dt, $J = 7.4$, 1.6 Hz, 1H), 7.42 (d, $J = 8.0$ Hz, 2H), 7.25 (d, $J = 8.0$ Hz, 2H), 7.22 (t, $J = 5.0$ Hz, 1H), 7.09 (q, $J = 7.6$ Hz, 3H), 6.85 (d, $J = 7.2$ Hz, 2H), 3.26 (d, $J = 18.4$ Hz,

1H), 3.04 (d, $J = 9.6$ Hz, 1H), 3.01 (d, $J = 9.6$ Hz, 1H), 2.92 (d, $J = 18.4$ Hz, 1H), 2.39 (s, 3H).

^{13}C NMR (100 MHz, CDCl_3) δ 194.8 (CO), 142.4 (C), 141.7 (C), 136.9 (C), 133.5 (CH), 133.1 (C), 132.4 (CH), 131.6 (C), 129.8 (CH), 129.4 (CH), 128.4 (CH), 128.0 (CH), 127.1 (CH), 126.4 (CH), 126.2 (CH), 42.8(CH₂), 35.3 (CH), 30.4 (C), 28.8 (CH), 21.3 (CH₃). HRMS-ESI calcd for $\text{C}_{24}\text{H}_{20}\text{O}$ ($M+\text{Na}$)⁺: 347.1424; found: 347.1412.

(1aR*,7bS*)-1a-(4-Methoxyphenyl)-1-phenyl-1a,2-dihydro-1H-cyclopropa[a]-naphthalen-3(7bH)-one (69c).

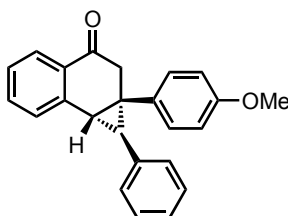

This compound was prepared by cyclization of enyne **44^c**, according to the general procedure **F** in 72% yield as a beige solid. mp 124-125 °C.

^1H NMR (400 MHz, CDCl_3) δ 7.60 (t, $J = 6.4$ Hz, 2H), 7.56 (dt, $J = 7.6, 1.2$ Hz, 1H), 7.46 (d, $J = 8.8$ Hz, 2H), 7.23 (dt, $J = 7.6, 1.2$ Hz, 1H), 7.10 (dq, $J = 7.6, 2.0$ Hz, 3H), 6.96 (d, $J = 8.8$ Hz, 2H), 6.86 (d, $J = 7.2$ Hz, 2H), 3.84 (s, 3H), 3.26 (d, $J = 18.4$ Hz, 1H), 3.03 (d, $J = 9.6$ Hz, 1H), 2.99 (d, $J = 9.6$ Hz, 1H), 2.91 (d, $J = 18.4$ Hz, 1H).

^{13}C NMR (100 MHz, CDCl_3) δ 194.8 (CO), 158.7 (C), 141.7 (C), 137.5 (C), 133.5 (CH), 133.1 (C), 132.4 (CH), 131.5 (C), 129.4 (CH), 129.3 (CH), 128.4 (CH), 127.1 (CH), 126.3 (CH), 126.2 (CH), 114.4 (CH), 55.6(CH₃), 43.0(CH₂), 35.3 (CH), 30.1 (C), 28.8 (CH). HRMS-ESI calcd for $\text{C}_{24}\text{H}_{20}\text{O}_2$ ($M+\text{Na}$)⁺: 363.1346; found: 363.1361.

(1aR*,7bS*)-1a-(4-Chlorophenyl)-1-phenyl-1a,2-dihydro-1H-cyclopropa[a]-naphthalen-3(7bH)-one (69d).

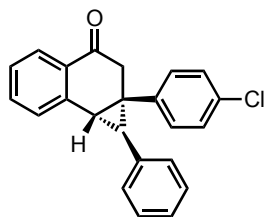

This compound was prepared by cyclization of enyne **44'd**, according to the general procedure **F** in 52% yield as a yellow oil.

^1H NMR (400 MHz, CDCl_3) δ 7.58 (dq, $J = 7.6, 1.2$ Hz, 3H), 7.47 (d, $J = 8.8$ Hz, 2H), 7.39 (d, $J = 8.8$ Hz, 2H), 7.24 (dt, $J = 7.6, 1.6$ Hz, 1H), 7.15-7.06 (m, 3H), 6.83 (d, $J = 6.4$ Hz, 2H), 3.26 (d, $J = 18.0$ Hz, 1H), 3.02 (s, 2H), 2.88 (d, $J = 18.0$ Hz, 1H).

^{13}C NMR (100 MHz, CDCl_3) δ 194.2 (CO), 143.8 (C), 141.2 (C), 133.7 (CH), 133.0 (C), 132.7 (C), 132.3 (CH), 131.5 (C), 129.6 (CH), 129.4 (CH), 129.3 (CH), 128.5 (CH), 127.3 (CH), 126.6 (CH), 126.3 (CH), 42.5 (CH_2), 35.4 (CH), 30.2 (C), 28.8 (CH). HRMS-ESI calcd for $\text{C}_{23}\text{H}_{17}\text{ClO}$ ($M+\text{Na}$) $^+$: 367.0856; found: 367.0866.

(1aR * , 7bS *)-1a-(4-Bromophenyl)-1-phenyl-1a,2-dihydro-1H-cyclopropa[a]-naphthalen-3(7bH)-one (69e).

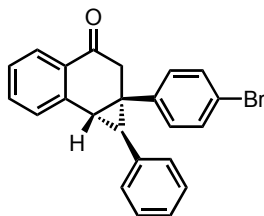

This compound was prepared by cyclization of enyne **44'e**, according to the general procedure **F** in 61% yield as white needles. mp 54-55 °C.

^1H NMR (400 MHz, CDCl_3) δ 7.66-7.57 (m, 3H), 7.59 (d, $J = 8.4$ Hz, 2H), 7.46 (d, $J = 8.4$ Hz, 2H), 7.29 (dt, $J = 7.6, 1.6$ Hz, 1H), 7.19-7.11 (m, 3H), 6.83 (d, $J = 6.4$ Hz, 2H), 3.30 (d, $J = 18.0$ Hz, 1H), 3.06 (s, 2H), 2.93 (d, $J = 18.0$ Hz, 1H).

^{13}C NMR (100 MHz, CDCl_3) δ 194.2 (CO), 144.3 (C), 141.1 (C), 133.7 (CH), 132.6 (C), 132.3 (C), 132.2 (CH), 131.5 (C), 129.9 (CH), 129.4 (CH), 128.5 (CH), 127.3 (CH), 126.6 (CH), 126.3 (CH), 121.0 (CH), 42.4 (CH_2), 35.3 (CH), 30.27 (C), 28.7 (CH). HRMS-ESI calcd for $\text{C}_{23}\text{H}_{17}\text{BrO}$ ($M+\text{Na}$) $^+$: 411.0367; found: 411.0360.

(1*R*^{*},1*aR*^{*},7*bS*^{*})-1*a*,2-Dihydro-1*a*-(4-nitrophenyl)-1-phenyl-1*H*-cyclopropa[*a*]naphthalen-3(7*bH*)-one (69f).

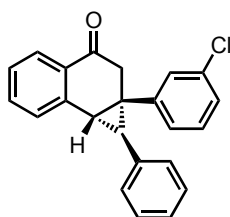

This compound was prepared by cyclization of enyne **44**^f, according to the general procedure **F**, in 47% yield as a brown oil.

^1H NMR (400 MHz, CDCl_3) δ 7.62 (dt, $J = 6.8, 1.6$ Hz, 1H), 7.61 (d, $J = 8.0$ Hz, 2H), 7.55 (dt, $J = 6.8, 1.6$ Hz, 1H), 7.43 (dd, 8.0, 1.2 Hz, 1H), 7.35-7.20 (m, 4H), 7.09 (d, $J = 8.0$ Hz, 2H), 6.97 (d, $J = 5.6$ Hz, 2H), 3.23 (d, $J = 18.4$ Hz, 1H), 3.08 (d, $J = 9.6$ Hz, 1H), 2.97 (d, $J = 9.6$ Hz, 1H), 2.93 (d, $J = 18.4$ Hz, 1H).

^{13}C NMR (100 MHz, CDCl_3) δ 194.5 (CO), 142.3 (C), 141.5 (C), 135.3 (C), 133.6 (CH), 133.1 (C), 132.4 (CH), 131.7 (CH), 131.5 (C), 130.4 (CH), 129.5 (CH), 128.9 (CH), 128.4 (CH), 127.5 (CH), 127.2 (CH), 126.4 (CH), 126.3 (CH), 40.4 (CH_2), 34.8 (CH), 30.5 (C), 29.2 (CH). HRMS-ESI calcd for $\text{C}_{23}\text{H}_{17}\text{ClO}$ ($M+\text{Na}$) $^+$: 367.0866; found: 367.0845.

(1*R*^{*},1*aR*^{*},7*bS*^{*})-1*a*,2-Dihydro-1-phenyl-1*a*-*o*-tolyl-1*H*-cyclopropa[*a*]naphthalen-3(7*bH*)-one (69g).

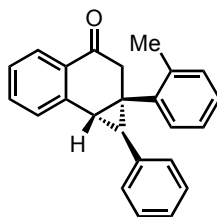

This compound was prepared by cyclization of enyne **44'g**, according to the general procedure **F** in 67% yield as a yellow oil.

^1H NMR (400 MHz, CDCl_3) δ 7.63-7.59 (m, 2H), 7.58-7.54 (m, 2H), 7.26-7.22 (m, 4H), 7.13-7.06 (m, 3H), 6.96-6.91 (m, 2H), 3.20 (d, $J = 19.2$ Hz, 1H), 3.06 (d, $J = 9.2$ Hz, 1H), 2.91 (d, $J = 9.2$ Hz, 1H), 2.81 (d, $J = 19.2$ Hz, 1H), 2.45 (s, 3H).

^{13}C NMR (100 MHz, CDCl_3) δ 194.8 (CO), 143.1 (C), 141.7 (C), 137.3 (C), 133.7 (CH), 133.4 (C), 132.3 (CH), 131.6 (C), 131.2 (CH), 130.3 (CH), 129.5 (CH), 128.4 (CH), 127.6 (CH), 127.1 (CH), 126.7 (CH), 126.5 (CH), 126.4 (CH), 41.2 (CH_2), 34.9 (CH), 30.4 (C), 29.2 (CH), 19.7 (CH_3). HRMS-ESI calcd for $\text{C}_{24}\text{H}_{20}\text{O}$ ($M+\text{Na}$) $^+$: 347.1417; found: 347.1412.

(1*R*^{*},1*aR*^{*},7*bS*^{*})-1*a*-(2-Ethylphenyl)-1*a*,2-dihydro-1-phenyl-1*H*-cyclopropa[*a*]naphthalen-3(7*bH*)-one (69h).

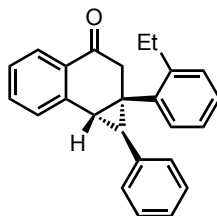

This compound was prepared by cyclization of enyne **44'h**, according to the general procedure **F** in 64% yield as a beige solid. mp 145-146.5 °C.

^1H NMR (400 MHz, CDCl_3) δ 7.61 (t, $J = 8.0$ Hz, 2H), 7.56 (tt, $J = 6.8, 1.2$ Hz, 2H), 7.31(m, 2H), 7.27 (t, $J = 8.0$ Hz, 1H), 7.25-7.22 (m, 1H), 7.13-7.07(m, 3H), 6.93(m, 2H), 3.21(d, $J = 18.4$ Hz, 1H), 3.07 (d, $J = 9.6$ Hz, 1H),

2.92 (d, $J = 9.6$ Hz, 1H), 2.84 (q, $J = 7.6$ Hz, 2H), 2.81 (d, $J = 18.4$ Hz, 1H), 1.29 (t, $J = 7.6$ Hz, 3H).

^{13}C NMR (100 MHz, CDCl_3) δ 194.7 (CO), 143.2 (C), 142.7 (C), 141.6 (C), 133.7 (CH), 133.4 (C), 132.3 (CHx2), 131.5 (C), 130.4 (CH), 129.5 (CH), 129.1 (CH), 128.4 (CH), 127.8 (CH), 127.1 (CH), 126.5 (CH), 126.4 (CH), 42.2 (CH₂), 34.8 (CH), 30.3 (C), 29.3 (CH), 24.7 (CH₂), 15.3 (CH₃). HRMS-ESI calcd for $\text{C}_{25}\text{H}_{22}\text{O}$ ($M+\text{Na}$)⁺: 361.1578; found: 361.1568.

(1*R*^{*},1*aS*^{*},7*bR*^{*})-1a-(2-Bromophenyl)-1-phenyl-1a,2-dihydro-1*H*-cyclopropa-[a]naphthalen-3(7*bH*)-one (69*i*) and (1*aR*^{*},1*aS*^{*},7*bS*^{*})-1a-(2-Bromophenyl)-1-phenyl-1a,2-dihydro-1*H*-cyclopropa[a]naphthalen-3(7*bH*)-one (69*i'*).

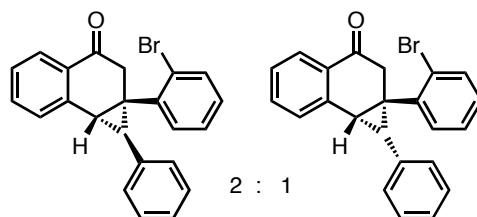

This mixture was prepared This compound was prepared by cyclization of enyne **44*i*** according to the general procedure **F** in (49%, *syn/anti* 2:1), as a beige solid.

^1H NMR (400 MHz, CDCl_3) δ 7.67-7.58 (m, 4H, *syn*), 7.57-7.53(m, 1H, *syn* + 4H, *Anti*), 7.43 (t, $J = 7.6$ Hz, 2H, *syn*), 7.39 (dt, $J = 7.6, 1.2$ Hz, 1H, *anti*), 7.32 (tt, $J = 7.2, 1.2$ Hz, 2H, *anti*), 7.24 (t, $J = 7.6$ Hz, 1H, *syn*), 7.20 (dt, $J = 7.6, 1.2$ Hz, 2H, *anti*), 7.14-7.07 (m, 3H, *syn* + 2H, *anti*), 6.97 (d, $J = 7.2$ Hz, 2H, *anti*), 6.86 (d, $J = 6.4$ Hz, 2H, *syn*), 3.29 (d, $J = 18.0$ Hz, 1H, *syn*), 3.18 (d, $J = 18.8$ Hz, 1H, *anti*), 3.11 (d, $J = 9.2$ Hz, 1H, *anti*), 3.07 (d, $J = 9.2$ Hz, 1H, *anti*), 3.06 (s, 2H, *syn*), 3.01 (d, $J = 18.8$ Hz, 1H, *anti*), 2.94 (d, $J = 18.0$ Hz, 1H, *syn*).

^{13}C NMR (100 MHz, CDCl_3) δ 194.7 (CO, *syn*), 194.5 (CO, *anti*), 145.3 (C, *syn*), 143.7 (C, *anti*), 141.6 (C, *syn*), 141.56 (C, *anti*), 133.8 (C, *syn*), 133.6 (C, *anti*), 133.58 (CH, *syn*), 133.2 (C, *syn*), 133.0 (C, *anti*), 132.4 (CHx2, *syn+anti*), 132.1 (CH, *anti*), 131.6 (CH, *syn*), 129.5 (CH, *anti*), 129.4 (CH, *syn*), 129.2 (CH, *anti*), 129.1 (CHx2, *syn+anti*), 128.9 (CH, *syn*), 128.4 (CHx2,

syn+anti), 128.2 (CH, *anti*), 128.1 (CH_{x2}, *syn+anti*), 127.2 (CH, *syn*), 127.19 (CH, *anti*), 127.16 (CH, *syn*), 126.5 (CH, *anti*), 126.4 (CH, *syn*), 126.3 (CH, *anti*), 126.2 (CH, *syn*), 125.4 (CH, *anti*), 42.7 (CH₂, *syn*), 40.5 (CH₂, *anti*), 35.3 (CH, *syn*), 35.0 (CH, *anti*), 32.3 (C, *anti*), 30.7 (C, *syn*), 29.7 (CH, *anti*), 28.8 (CH, *syn*). HRMS-ESI calcd for C₂₃H₁₇BrO (*M*+Na)⁺: 411.0374; found: 411.0360.

Enynes 44a-j. Scheme 2.12.

1-(3-Methoxy-3-(2-styrylphenyl)prop-1-ynyl)benzene (44a).

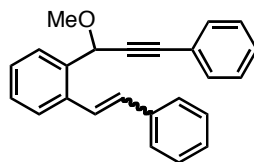

This compound was prepared by methylation of 3-phenyl-1-(2-styrylphenyl)prop-2-yn-1-ol (**44'a**), according to the general procedure C. Yellow oil (92%, 4:1 *E/Z*).

¹H NMR (400 MHz, CDCl₃) δ 7.76 (d, *J* = 7.6 Hz, 1H, *E*), 7.72-7.62 (m, 4H, *Z*), 7.55 (d, *J* = 7.4 Hz, 2H, *Z*), 7.44-7.37 (m, 3H, *E* + 1H, *Z*), 7.31-7.25 (m, 4H, *E* + 2H, *Z*), 7.20-7.11 (m, 6H, *E* + 4H, *Z*), 7.04 (d, *J* = 7.4 Hz, 1H, *Z*), 6.91 (d, *J* = 7.6 Hz, 1H, *Z*), 6.85 (d, *J* = 12.4 Hz, 1H, *E*), 6.72 (d, *J* = 12.4 Hz, 1H, *E*), 6.68 (d, *J* = 7.6 Hz, 1H, *Z*), 5.55 (s, 1H, *Z*), 5.46 (s, 1H, *E*), 3.54 (s, 3H, *Z*), 3.47 (s, 3H, *E*). Signals for major isomer (*E*).

¹³C NMR (100 MHz, CDCl₃) δ 137.1 (C), 136.7 (C), 136.6 (C), 131.9 (CH), 131.8 (CH), 129.8 (CH), 129.4 (CH), 128.6 (CH), 128.57 (CH), 128.4 (CH), 128.3 (CH), 128.27 (CH), 127.8 (CH), 127.76 (CH), 127.4 (CH), 122.8 (C), 87.7 (C), 86.9 (C), 71.6 (CH), 56.6 (OCH₃). HRMS-ESI calcd for C₂₄H₂₀O (*M*+Na)⁺: 347.1401; found: 347.1412.

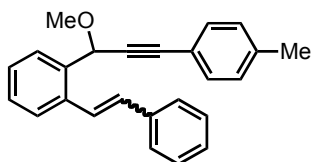
1-(3-Methoxy-3-(2-styrylphenyl)prop-1-ynyl)-4-methylbenzene (44b).

This compound was prepared by methylation of 1-(2-styrylphenyl)-3-*p*-tolylprop-2-yn-1-ol (**44'b**) according to the general procedure C. Yellow oil (91%, 5:1 *E/Z*). Signals for major isomer (*E*).

^1H NMR (400 MHz, CDCl_3) δ 7.76 (d, $J = 7.6$ Hz, 1H), 7.35-7.27 (m, 2H), 7.30 (d, $J = 8.8$ Hz, 2H), 7.20-7.11 (m, 2H), 7.15-7.13 (m, 4H), 7.09 (d, $J = 8.8$ Hz, 2H), 6.87 (d, $J = 12.4$ Hz, 1H), 6.71 (d, $J = 12.4$ Hz, 1H), 5.46 (s, 1H), 5.48 (s, 3H), 2.33 (s, 3H).

^{13}C NMR (100 MHz, CDCl_3) δ 138.7 (CH), 137.1 (C), 136.8 (CH), 135.6 (C), 131.8 (CH), 131.7 (CH), 129.8 (CH), 129.4 (CH), 129.1 (CH), 128.2 (CH), 127.8 (CH), 127.3 (CH), 126.9 (CH), 120.4 (C), 119.7 (C), 110.8 (C), 87.9 (C), 86.2 (C), 71.6 (CH), 56.5 (OCH_3), 21.6 (CH_3). HRMS-ESI calcd for $\text{C}_{25}\text{H}_{22}\text{O}$ ($M+\text{Na}$) $^+$: 361.1571; found: 361.1568.

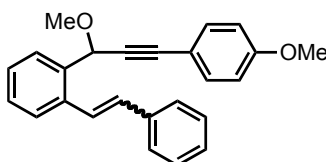
1-(2-(1-Methoxy-3-(4-methoxyphenyl)prop-2-ynyl)styryl)benzene (44c).

This compound was prepared by methylation of 3-(4-methoxyphenyl)-1-(2-styrylphenyl)prop-2-yn-1-ol (**44'c**) according to the general procedure C. Colorless oil (90%, 6:1 *E/Z*). Signals for major isomer (*E*).

^1H NMR (400 MHz, CDCl_3) δ 7.75 (d, $J = 7.6$ Hz, 1H), 7.36-7.31 (m, 3H), 7.17-7.09 (m, 7H), 6.86 (d, $J = 12.4$ Hz, 1H), 6.80 (d, $J = 8.8$ Hz, 2H), 6.70 (d, $J = 12.4$ Hz, 1H), 5.44 (s, 1H), 3.79 (s, 3H), 3.46 (s, 3H). ^{13}C NMR (100 MHz, CDCl_3) δ 159.9 (C), 137.1 (C), 136.9 (C), 136.8 (C), 133.4 (CH), 131.7 (CH),

129.8 (CH), 129.4 (CH), 128.6 (CH), 128.4 (CH), 128.3 (CH), 127.8 (CH), 127.78 (CH), 127.4 (CH), 115.0 (C), 114.0 (CH), 87.7 (C), 85.5 (C), 71.7 (CH), 56.6 (CH₃), 55.5 (CH₃). HRMS-ESI calcd for C₂₅H₂₂O₂ (M+Na)⁺: 377.1517; found: 377.1510.

1-Chloro-4-(3-Methoxy-3-(2-styrylphenyl)prop-1-ynyl)benzene (44d).

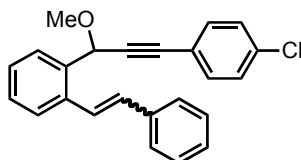

This compound was prepared by methylation of 3-(4-chlorophenyl)-1-(2-styrylphenyl)prop-2-yn-1-ol (**44'd**) according to the general procedure C. Brown-red oil (87%, 4:1 *E/Z*). Signals for major isomer (*E*).

¹H NMR (400 MHz, CDCl₃) δ 7.72 (d, *J* = 7.4 Hz, 1H), 7.34-7.28(m, 4H), 7.26-7.17 (m, 3H), 7.14-7.11 (m, 5H), 6.84 (d, *J* = 12.0 Hz, 1H), 6.70 (d, *J* = 12.0 Hz, 1H), 5.43 (s, 1H), 3.46 (s, 3H). Selected signals for minor isomer (*Z*).

¹H NMR (400 MHz, CDCl₃) δ 7.68-7.60 (m, 5H), 7.56-7.52 (m, 3H), 7.02 (d, *J* = 7.4 Hz, 1H), 5.51 (s, 1H), 3.52 (s, 3H). Signals form major isomer (*E*).

¹³C NMR (100 MHz, CDCl₃) δ 137.7 (CH), 137.1 (C), 136.7 (C), 136.5 (C), 135.5 (CH), 134.6 (C), 133.2 (CH), 131.9 (CH), 129.9 (CH), 129.4 (CH), 128.7 (CH), 128.3 (CH), 128.26 (CH), 127.9 (CH), 127.5 (CH), 121.3 (C), 88.0 (C), 86.5 (C), 71.6 (CH), 56.7 (CH₃). HRMS-ESI calcd for C₂₄H₁₉ClO (M+Na)⁺: 381.1027; found: 381.1022.

1-Bromo-4-(3-methoxy-3-(2-styrylphenyl)prop-1-ynyl)benzene (44e).

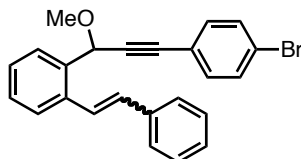

This compound was prepared by methylation of 3-(4-bromophenyl)-1-(2-styrylphenyl)prop-2-yn-1-ol (**44'e**) according to the general procedure C. Signals for major isomer (*E*). Yellow oil (84%, *E/Z* 2:1).

^1H NMR (400 MHz, CDCl_3) δ 7.76 (d, $J = 7.4$ Hz, 1H, *Z*), 7.71 (d, $J = 7.4$ Hz, 1H, *E*), 7.42-7.29 (m, 4H, *E* + 4H, *Z*), 7.27-7.18 (m, 3H, *E* + 3H, *Z*), 7.14-7.09 (m, 5H, *E* + 5H, *Z*), 6.86 (d, $J = 8.0$ Hz, 1H, *E*), 6.83 (d, $J = 12.4$ Hz, 1H, *Z*), 6.71 (d, $J = 8.0$ Hz, 1H, *E*), 6.70 (d, $J = 12.4$ Hz, 1H, *Z*), 5.45 (s, 1H, *Z*), 5.42 (s, 1H, *E*), 3.47 (s, 3H, *Z*), 3.45 (s, 3H, *E*).

^{13}C NMR (100 MHz, CDCl_3) δ 137.1 (C, *E*), 136.8 (C, *Z*), 136.7 (C, *E*), 136.69 (C, *Z*), 136.4 (C, *Z*), 135.5 (C, *E*), 133.4 (CH, *E*), 132.0 (CH, *Z*), 131.9 (CH, *E*), 131.8 (CH, *Z*), 131.7 (CH, *E*), 131.68 (CH, *Z*), 129.9 (CH, *E*), 129.8 (CH, *Z*), 129.4 (CH, *Z*), 128.7 (CH, *E*), 128.66 (CH, *Z*), 128.6 (CH, *E*), 128.4 (CH, *Z*), 128.36 (CH, *E*), 128.3 (CH, *E*), 128.2 (CH, *E*), 127.9 (CH, *Z*), 127.8 (CH, *E*), 127.79 (CH, *Z*), 127.7 (CH, *E*), 127.5 (CH, *Z*), 127.4 (CH, *E*), 126.9 (CH, *Z*), 122.9 (C, *E*), 121.8 (C, *Z*), 88.2 (C, *E*), 87.7 (C, *Z*), 86.9 (C, *Z*), 86.5 (C, *E*), 72.1 (CH, *Z*), 71.6 (CH, *E*), 56.7 (CH_3 , *E*), 56.6 (CH_3 , *Z*). HRMS-ESI calcd for $\text{C}_{24}\text{H}_{19}\text{BrO}$ ($M+\text{Na}$) $^+$: 425.0514; found: 425.0517.

1-(3-(3-Chlorophenyl)-1-methoxyprop-2-yn-1-yl)-2-styrylbenzene (**44f**).

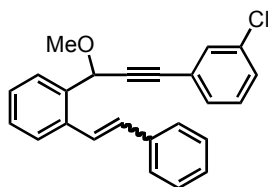

This compound was prepared by methylation of 3-(3-chlorophenyl)-1-(2-styrylphenyl)prop-2-yn-1-ol (**44'f**) according to the general procedure C. Brown dark oil (92%, *Z/E* 2:1).

^1H NMR (400 MHz, CDCl_3) δ 7.88 (dd, $J = 8.4, 1.2$ Hz, 1H, *E*), 7.82 (d, $J = 7.4$ Hz, 1H, *Z*), 7.70-7.65 (m, 1H, *E*), 7.57-7.49 (m, 2H, *E*), 7.45 (dd, $J = 8.4, 1.2$ Hz, 1H, *E*), 7.40 (dt, $J = 7.8, 1.2$ Hz, 1H, *E* + 3H, *Z*), 7.35-7.28 (m, 4H, *E* + 1H, *Z*), 7.25-7.21 (m, 4H, *E*), 7.18 (dt, $J = 7.6, 1.2$ Hz, 3H, *Z*), 7.15-7.11 (m, 5H, *Z*), 7.04 (d, $J = 16.2$ Hz, *E*), 6.87 (d, $J = 12.2$ Hz, 1H, *Z*), 6.71 (d, $J =$

12.2 Hz, 1H, *Z*), 5.71 (s, 1H, *E*), 5.53 (s, 1H, *Z*), 3.87 (s, 3H, *E*), 3.51 (s, 3H, *Z*). Signals for major isomer (*Z*).

^{13}C NMR (100 MHz, CDCl_3) δ 137.2 (C), 136.8 (C), 136.4 (C), 136.3 (C), 133.7 (CH), 131.7 (CH), 129.8 (CH), 129.7 (CH), 129.4 (CH), 128.7 (C), 128.3 (CH), 128.0 (CH), 127.8 (CH), 127.4 (CH), 127.3 (CH), 126.6 (CH), 126.5 (CH), 122.8 (CH), 92.2 (C), 84.6 (C), 71.6 (CH), 56.6 (OCH_3). Selected signals for minor isomer (*E*). 136.1 (C), 133.7 (CH), 133.7 (CH), 130.0 (CH), 129.86 (CH), 129.84 (CH), 129.6 (CH), 129.5 (CH), 128.9 (C), 128.6 (CH), 126.9 (CH), 122.6 (CH), 91.4 (C), 70.6 (CH), 56.9 (OCH_3). HRMS-ESI calcd for $\text{C}_{24}\text{H}_{19}\text{ClO}$ ($M+\text{Na}$) $^+$: 381.1022; found: 381.1005.

1-(3-Methoxy-3-(2-styrylphenyl)prop-1-ynyl)-2-methylbenzene (44g).

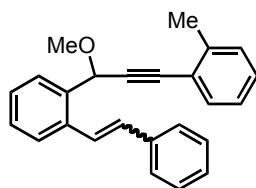

This compound was prepared by methylation of 1-(2-styrylphenyl)-3-(*o*-tolyl)prop-2-yn-1-ol (**44'g**) according to the general procedure C. Yellow oil (93%, 5:1 *E/Z*). Signals for major isomer (*E*).

^1H NMR (400 MHz, CDCl_3) δ 7.79 (d, $J = 7.6$ Hz, 1H), 7.39-7.32 (m, 2H), 7.21-7.15 (m, 4H), 7.14-7.09 (m, 6H), 6.87 (d, $J = 12.0$ Hz, 1H), 6.70 (d, $J = 12.0$ Hz, 1H), 5.52 (s, 1H), 3.49 (s, 3H), 2.42 (s, 3H).

^{13}C NMR (100 MHz, CDCl_3) δ 140.3 (CH), 137.0 (C), 136.8 (C), 136.7 (CH), 132.2 (CH), 131.7 (CH), 129.7 (CH), 129.5 (CH), 129.3 (CH), 128.55 (CH), 128.2 (CH), 127.7 (CH), 127.3 (CH), 126.8 (C), 125.6 (CH), 122.6 (CH), 120.3 (C), 110.8 (C), 90.8 (C), 86.7 (C), 71.6 (CH), 56.4 (OCH_3), 20.9 (CH_3). HRMS-ESI calcd for $\text{C}_{25}\text{H}_{22}\text{O}$ ($M+\text{Na}$) $^+$: 361.1571; found: 361.1568.

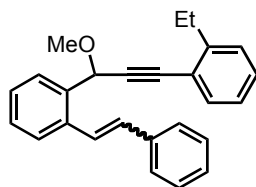
1-Ethyl-2-(3-methoxy-3-(2-styrylphenyl)prop-1-ynyl)benzene (44h).

This compound was prepared by methylation of 3-(2-ethylphenyl)-1-(2-styrylphenyl)prop-2-yn-1-ol (**44'h**) according to the general procedure C. Yellow oil (85%, 8:1 *E/Z*). Signals for major isomer (*E*).

^1H NMR (400 MHz, CDCl_3) δ 7.79 (d, $J = 7.4$ Hz, 1H), 7.40-7.36 (m, 1H), 7.27-7.22 (m, 2H), 7.20-7.16 (m, 3H), 7.14-7.10 (m, 6H), 6.86 (d, $J = 12.4$ Hz, 1H), 6.70 (d, $J = 12.4$ Hz, 1H), 5.51 (s, 1H), 3.49 (s, 3H), 2.79 (q, $J = 7.2$ Hz, 2H), 1.21 (t, $J = 7.2$ Hz, 2H).

^{13}C NMR (100 MHz, CDCl_3) δ 146.5 (C), 137.0 (C), 136.8 (C), 136.7 (C), 132.6 (CH), 131.8 (CH), 129.7 (CH), 129.4 (CH), 128.8 (CH), 128.6 (CH), 128.3 (CH), 128.2 (CH), 128.1 (CH), 127.8 (CH), 127.77 (CH), 127.4 (CH), 125.7 (CH), 121.9 (C), 90.4 (C), 86.5 (C), 71.6 (CH), 56.5 (OCH_3), 27.9 (CH_2), 15.1 (CH_3). HRMS-ESI calcd for $\text{C}_{26}\text{H}_{24}\text{O}$ ($M+\text{Na}$) $^+$: 375.1713; found: 375.1725.

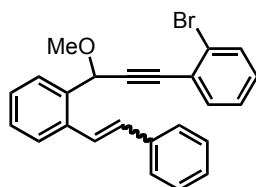
1-Bromo-2-(3-methoxy-3-(2-styrylphenyl)prop-1-ynyl)benzene (44i).

This compound was prepared by methylation of 3-(2-bromophenyl)-1-(2-styrylphenyl)prop-2-yn-1-ol (**44'i**) according to the general procedure C. Yellow oil (88%, 5:1 *E/Z*).

^1H NMR (400 MHz, CDCl_3) δ 7.83 (d, $J = 7.2$ Hz, 1H, *Z*), 7.75 (dd, $J = 8.0$, 1.6 Hz, 1H, *E*), 7.66 (d, $J = 5.6$ Hz, 1H, *E* + 3H, *Z*), 7.62 (bs, 3H, *Z*), 7.58-7.53 (m, 3H, *E*), 7.42 (dd, $J = 7.8$, 1.2 Hz, 4H, *Z*), 7.36 (t, $J = 7.6$ Hz, 4H, *E*),

7.29 (t, $J = 7.6$ Hz, 1H, $E + 1H$, Z), 7.22-7.12 (m, 4H, $E + 1H$, Z), 7.03 (d, $J = 16.0$ Hz, 1H, E), 6.87 (d, $J = 12.0$ Hz, 1H, Z), 6.70 (d, $J = 12.0$ Hz, 1H, Z), 5.63 (s, 1H, E), 5.52 (s, 1H, Z), 3.58 (s, 3H, E), 3.52 (s, 3H, Z). Signals for major isomer (E).

^{13}C NMR (100 MHz, CDCl_3) δ 137.7 (C), 136.9 (C), 135.4 (C), 133.8 (CH), 132.6 (CH), 131.6 (CH), 129.9 (CH), 129.1 (CH), 128.9 (CH), 128.6 (CH), 127.9 (CH), 127.8 (CH), 127.2 (CH), 127.0 (CH), 126.6 (CH), 126.1 (CH), 125.8 (C), 125.0 (C), 91.4 (C), 87.0 (C), 71.9 (CH), 56.4 (CH_3). HRMS-ESI calcd for $\text{C}_{24}\text{H}_{19}\text{BrO}$ ($M+\text{Na}$) $^+$: 425.0535; found: 425.0541.

2-(3-Methoxy-3-(2-styrylphenyl)prop-1-yn-1-yl)dibenzo[*b,d*]furan (**44j**).

(E)-2-styrylbenzaldehyde (**S1**)¹⁶ and 2-iododibenzo[*b,d*]furan (**S3**)¹⁷ were prepared according the literature procedures.

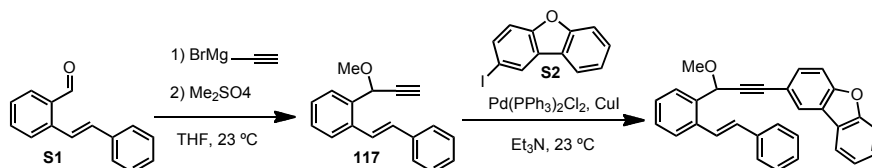

(E)-1-(1-Methoxyprop-2-yn-1-yl)-2-styrylbenzene (**117**). (E)-2-styrylbenzaldehyde **S1** (208.1 mg, 1.00 mmol) was dissolved in 2 mL of dry THF. Ethynylmagnesium bromide 0.5 M (2.2 mL, 1.1 mmol) was added in one portion. The reaction was stirred at room temperature by 15 min, then dimethyl sulfate (0.38 mL, 4.0 mmol) was added. The mixture was stirred overnight. The reaction was stopped by addition of ether and sat. NH_4Cl solution. The aqueous phase was extracted with EtOAc, the combined organic extract was dried over MgSO_4 , and the solvent was evaporated. The crude reaction mixture was purified by flash chromatography to yield 90% of **117** as yellow oil.

^1H NMR (400 MHz, CDCl_3) δ 7.65 (dd, $J = 4.0, 0.8$ Hz, 1H), 7.63 (dd, $J = 4.0, 0.8$ Hz, 1H), 7.54 (t, $J = 7.6$ Hz, 3H), 7.37 (t, $J = 7.6$ Hz, 3H), 7.34-7.24 (m, 2H), 7.01 (d, $J = 16.4$ Hz, 1H), 5.34 (d, $J = 2.0$ Hz, 1H), 3.48 (s, 3H), 2.68 (d, $J = 2.0$ Hz, 1H).

^{13}C NMR (101 MHz, CDCl_3) δ 137.6 (C), 136.7 (C), 135.1 (C), 131.55 (CH), 129.0 (CH), 128.9 (CH), 128.2 (CH), 128.0 (CH), 127.8 (CH), 126.9 (CH), 126.5 (CH), 125.7 (CH), 81.2 (C), 76.5 (CH), 71.1 (CH), 56.2 (OCH_3). HRMS-ESI calcd for $\text{C}_{18}\text{H}_{16}\text{O}$ ($M+\text{Na}^+$): 271.1099; found: 271.1099.

2-(3-Methoxy-3-(2-styrylphenyl)prop-1-yn-1-yl)dibenzo[*b,d*]furan (44j). This compound was prepared according to the general procedure **D** starting from alkyne **S2** and iodide **S3**. Yellow-green oil (90%, *Z/E* 8:1).

Signals for major isomer. ^1H NMR (400 MHz, CDCl_3) δ 7.96 (d, $J = 0.8$ Hz, 1H), 7.86 (d, $J = 5.6$ Hz, 1H), 7.81 (d, $J = 6.4$ Hz, 1H), 7.56 (tt, $J = 6.4, 0.8$ Hz, 1H), 7.47 (t, $J = 6.4$ Hz, 3H), 7.37-7.33 (m, 2H), 7.23-7.20 (m, 2H), 7.18-7.14 (m, 5H), 6.91 (d, $J = 10.0$ Hz, 1H), 6.74 (d, $J = 10.0$ Hz, 1H), 5.50 (s, 1H), 3.53 (s, 3H).

^{13}C NMR (100 MHz, CDCl_3) δ 156.7 (C), 156.0 (C), 137.1 (C), 136.8 (CH), 131.8 (CH), 131.1 (CH), 129.9 (CH), 129.5 (CH), 128.7 (CH), 128.4 (CH), 128.3 (CH), 127.9 (CH), 127.8 (CH), 127.77 (CH), 127.4 (C), 127.0 (C), 124.58 (CH), 124.55 (C), 123.7 (C), 123.2 (CH), 120.9 (CH), 117.3 (C), 111.9 (CH), 111.8 (CH), 87.7 (C), 86.0 (C), 71.7 (CH), 56.7 (OCH_3). HRMS-ESI calcd for $\text{C}_{30}\text{H}_{22}\text{O}_2$ ($M+\text{Na}^+$): 437.1534; found: 437.1517.

Naphthalenes 73a-j. Scheme 2.13.

1-Methoxy-3-phenylnaphthalene (73a).¹⁸

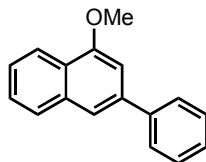

This compound was prepared by cyclization of enyne **44a** according to the general procedure **F**, in 57% yield as a yellow oil. ^1H NMR (400 MHz, CDCl_3) δ 8.27 (d, $J = 8.4$ Hz, 1H), 7.86 (d, $J = 8.6$ Hz, 1H), 7.73 (d, $J = 8.4$ Hz, 2H), 7.64 (bs, 1H), 7.55-7.45 (m, 4H), 7.39 (tt, $J = 7.2, 1.2$ Hz, 1H), 7.07 (d, $J = 1.2$ Hz,

1H), 4.08 (s, 3H).

^{13}C NMR (101 MHz, CDCl_3) δ 156.0 (C), 141.9 (C), 139.1 (C), 134.8 (C), 129.0 (CH), 128.0 (CH), 127.65 (CH), 127.6 (CH), 127.1 (CH), 125.5 (CH), 125.0 (C), 122.1 (CH), 118.6 (CH), 104.0 (CH), 55.8 (OCH₃). HRMS-ESI calcd for C₁₇H₁₄O ($M+\text{Na}$)⁺: 257.0938; found: 257.0935.

1-Methoxy-3-*p*-tolyl naphthalene (73b).

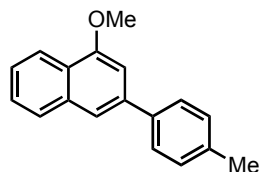

This compound was prepared by cyclization of enyne **44b** according to the general procedure **F**, in 50% yield as a yellow oil.

^1H NMR (400 MHz, CDCl_3) δ 8.26 (d, $J = 8.4$ Hz, 1H), 7.85 (d, $J = 8.4$ Hz, 1H), 7.63 (d, $J = 8.0$ Hz, 2H), 7.62 (s, 1H), 7.52 (dt, $J = 8.4$ Hz, 1.2 Hz, 1H), 7.47 (dt, $J = 8.4$ Hz, 1.2 Hz, 1H), 7.31 (d, $J = 8.0$ Hz, 2H), 7.07 (d, $J = 1.2$ Hz, 1H), 4.08 (s, 3H), 2.44 (s, 3H).

^{13}C NMR δ 155.9 (C), 139.0 (C), 138.9 (C), 137.4 (C), 134.8 (C), 129.7 (CH), 127.9 (CH), 127.4 (CH), 127.0 (CH), 125.3 (CH), 124.9 (C), 122.1 (CH), 118.3 (CH), 103.9 (CH), 55.8 (OCH₃), 21.4 (CH₃). HRMS-APCI calcd for C₁₈H₁₇O ($M+\text{H}$)⁺: 249.1218; found: 249.1279.

1-Methoxy-3-(4-methoxyphenyl)naphthalene (73c).

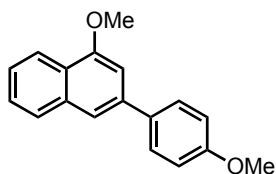

This compound was prepared by cyclization of enyne **44c** according to the general procedure **F**, in 65% yield as a red oil.

^1H NMR (400 MHz, CDCl_3) δ 8.25 (d, $J = 8.0$ Hz, 1H), 7.83 (d, $J = 8.0$ Hz, 1H), 7.66 (d, $J = 8.4$ Hz, 2H), 7.59 (bs, 1H), 7.51 (t, $J = 8.0, 1.2$ Hz, 1H), 7.46 (t, $J = 8.0, 1.2$ Hz, 1H), 7.04 (s, 1H), 7.03 (d, $J = 8.4$ Hz, 2H), 4.08 (s, 3H), 3.88 (s, 3H).

^{13}C NMR (100 MHz, CDCl_3) δ 159.4 (C), 155.9 (C), 138.7 (C), 134.9 (C), 134.4 (C), 128.6 (CH), 127.8 (CH), 126.9 (CH), 125.2 (CH), 124.7 (C), 122.1 (CH), 117.9 (CH), 114.4 (CH), 103.9 (CH), 55.8 (CH), 55.6 (OCH_3). HRMS-APCI calcd for $\text{C}_{18}\text{H}_{17}\text{O}_2(\text{M}+\text{H})^+$: 265.1239; found; 265.1233.

3-(4-Chlorophenyl)-1-methoxynaphthalene (73d).

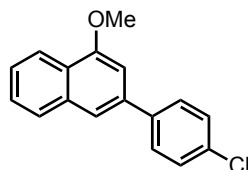

This compound was prepared by cyclization of enyne **44d** according to the general procedure F, in 47% yield as a red solid. mp 54-55 °C.

^1H NMR (400 MHz, CDCl_3) δ 8.25 (dd, $J = 8.0, 1.2$ Hz, 1H), 7.83 (dd, $J = 6.8, 1.6$ Hz, 1H), 7.63 (d, $J = 8.4$ Hz, 2H), 7.58 (bs, 1H), 7.53-7.47 (m, 2H), 7.44 (d, $J = 8.4$ Hz, 2H), 6.98 (d, $J = 1.2$ Hz, 1H), 4.06 (s, 3H);

^{13}C NMR (100 MHz, CDCl_3) δ 156.2 (C), 140.3 (C), 137.8 (C), 134.7 (C), 133.6 (C), 129.1 (CH), 128.8 (CH), 127.9 (CH), 127.2 (CH), 125.7 (CH), 125.1 (C), 122.2 (CH), 118.6 (CH), 103.6 (CH), 55.8 (OCH_3). MALDI calcd for $\text{C}_{17}\text{H}_{13}\text{ClO}(\text{M})^+$ 268.0655; found; 268.0644.

3-(4-Bromophenyl)-1-methoxynaphthalene (73e).

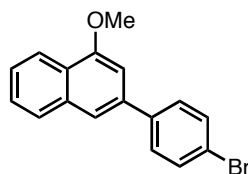

This compound was prepared by cyclization of enyne **44e** according to the general procedure **F**, in 51% yield as a red-dark oil.

^1H NMR (400 MHz, CDCl_3) δ 8.25 (dd, $J = 8.0, 2.0$ Hz, 1H), 7.82 (dd, $J = 7.6, 1.6$ Hz, 1H), 7.58 (d, $J = 4.8$ Hz, 4H), 7.53-7.45 (m, 3H), 6.97 (d, $J = 1.6$ Hz, 1H), 4.05 (s, 3H).

^{13}C NMR (100 MHz, CDCl_3) δ 156.2 (C), 140.7 (C), 137.8 (C), 134.7 (C), 132.1 (CH), 129.2 (CH), 127.9 (CH), 127.2 (CH), 125.7 (CH), 125.1 (C), 122.2 (CH), 121.8 (C), 118.5 (CH), 103.5 (CH), 55.8 (OCH₃). MALDI calcd for $\text{C}_{17}\text{H}_{13}\text{BrO}$ (M)⁺ 312.0144; found; 312.0157.

3-(3-Chlorophenyl)-1-methoxynaphthalene (**73f**).

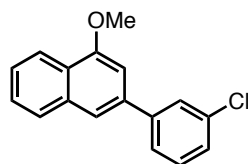

This compound was prepared by cyclization of enyne **44f** according to the general procedure **F**, in 45% yield as yellow needles. mp 69-69.5 °C.

^1H NMR (400 MHz, CDCl_3) δ 8.28 (dd, $J = 8.0, 2.0$ Hz, 1H), 7.83 (dd, $J = 8.0, 2.4$ Hz, 1H), 7.54-7.45 (m, 4H), 7.34 (dq, $J = 6.8, 2.4$ Hz, 3H), 6.93 (d, $J = 0.8$ Hz, 1H), 4.03 (s, 3H).

^{13}C NMR (100 MHz, CDCl_3) δ 155.1 (C), 141.1 (C), 137.4 (C), 134.3 (C), 132.9 (C), 131.7 (CH), 130.2 (CH), 128.8 (CH), 127.9 (CH), 127.0 (CH), 126.99 (CH), 125.8 (CH), 125.1 (C), 122.2 (CH), 121.0 (CH), 106.2 (CH), 55.8 (OCH₃). MALDI calcd for $\text{C}_{17}\text{H}_{13}\text{ClO}$ (M)⁺ 268.0655; found; 268.0644.

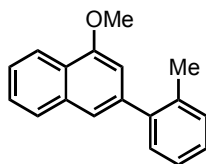
1-Methoxy-3-*o*-tolynaphthalene (73g).

This compound was prepared by cyclization of enyne **44g** according to the general procedure **F**, in 58% yield as yellow-dark oil.

^1H NMR δ 8.28 (dd, $J = 8.0, 1.6$ Hz, 1H), 7.81 (dd, $J = 8.0, 1.6$ Hz, 1H), 7.50 (dq, $J = 8.0, 2.0$ Hz, 2H), 7.36-7.28 (m, 5H), 6.81 (d, $J = 1.6$ Hz, 1H), 4.01 (s, 3H), 2.33 (s, 3H).

^{13}C NMR δ 155.2 (C), 142.5 (C), 139.9 (C), 135.8 (C), 134.5 (C), 130.5 (CH), 130.0 (CH), 127.8 (CH), 127.6 (CH), 126.9 (CH), 125.9 (CH), 125.4 (CH), 124.7 (C), 122.1 (CH), 120.4 (CH), 106.2 (CH), 55.8 (OCH₃), 20.7 (CH₃). HRMS-APCI calcd for C₁₈H₁₇O (M+H)⁺: 249.1249; found: 249.1279.

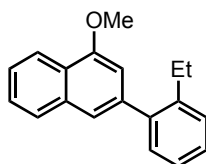
3-(2-Ethylphenyl)-1-methoxynaphthalene (73h).

This compound was prepared by cyclization of enyne **44h** according to the general procedure **F**, in 61% yield as an amber oil.

^1H NMR (400 MHz, CDCl₃) δ 8.27 (dd, $J = 8.0, 1.6$ Hz, 1H), 7.79 (dd, $J = 7.6, 1.6$ Hz, 1H), 7.49 (dq, $J = 8.0, 1.6$ Hz, 2H), 7.35-7.25 (m, 5H), 6.79 (d, $J = 0.8$ Hz, 1H), 3.99 (s, 3H), 2.65 (q, $J = 7.6$ Hz, 2H), 1.13 (t, $J = 7.6$ Hz, 3H).

^{13}C NMR (100 MHz, CDCl₃) δ 155.1 (C), 142.2 (C), 142.0 (C), 139.9 (C), 134.4 (C), 130.2 (CH), 128.8 (CH), 127.8 (CH), 126.9 (CH), 125.7 (CH), 125.3 (CH), 124.7 (C), 122.1 (CH), 120.4 (CH), 106.4 (CH), 100.2 (CH), 55.8 (OCH₃), 26.5 (CH₂), 16.0 (CH₃). HRMS-APCI calcd for C₁₉H₁₈O (M+H)⁺: 263.1437; found:

263.1436.

3-(2-Bromophenyl)-1-methoxynaphthalene (73i).

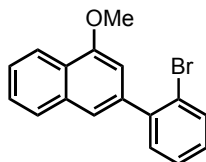

This compound was prepared by cyclization of enyne **44i** according to the general procedure **F**, in 42% yield as a red oil.

^1H NMR (400 MHz, CDCl_3) δ (dd, $J = 9.2, 2.4$ Hz, 1H), 7.83 (dd, $J = 8.8, 2.4$ Hz, 1H), 7.71 (dd, $J = 7.2, 0.8$ Hz, 1H), 7.54-7.47 (m, 2H), 7.46-7.37 (m, 3H), 7.26-7.22 (m, 1H), 6.90 (d, $J = 0.6$ Hz, 1H), 4.03 (s, 3H).

^{13}C NMR (100 MHz, CDCl_3) δ 155.0 (C), 143.2 (C), 139.1 (C), 134.3 (C), 133.4 (CH), 131.7 (CH), 129.0 (CH), 129.0 (CH), 127.6 (CH), 127.0 (CH), 125.8 (CH), 125.1 (C), 122.9 (C), 122.18 (CH), 120.8 (CH), 106.3 (CH), 55.9 (OCH₃). MALDI calcd for $\text{C}_{17}\text{H}_{13}\text{BrO}$ (M)⁺ 312.0144; found; 311.9981.

2-(4-Methoxynaphthalen-2-yl)dibenzo[*b,d*]furan (73j).

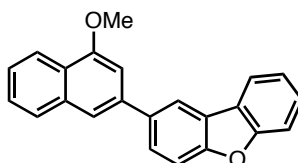

This compound was prepared by cyclization of enyne **44j** according to the general procedure **F**, in 71% yield as a brown oil.

^1H NMR (400 MHz, CDCl_3) δ 8.28 (d, $J = 8.4$ Hz, 1H), 8.25 (d, $J = 0.8$ Hz, 1H), 8.04 (d, $J = 7.6$ Hz, 1H), 7.80 (dd, $J = 7.8, 1.2$ Hz, 1H), 7.69 (bs, 1H), 7.66 (d, $J = 8.4$ Hz, 1H), 7.61 (d, $J = 8.4$ Hz, 1H), 7.53-7.46 (m, 3H), 7.38 (t, $J = 7.6$ Hz, 1H), 7.14 (d, $J = 0.8$ Hz, 1H), 4.12 (s, 3H).

^{13}C NMR δ 156.9 (C), 156.1 (C), 156.0 (C), 139.3 (C), 137.1 (C), 134.9 (C),

127.9 (CH), 127.6 (CH), 127.1(CH_x2), 125.4 (CH), 125.0 (C), 124.9 (C), 124.5 (C), 123.0 (CH), 122.2 (CH), 121.0 (CH), 119.6 (CH), 118.8 (CH), 112.0 (CH_x2), 104.4 (CH), 55.9 (OCH₃). HRMS-APCI calcd for C₂₃H₁₇O₂ (M+H)⁺: 325.1223; found: 325.1229.

Tetracyclic compounds 74a-d. Scheme 2.14.

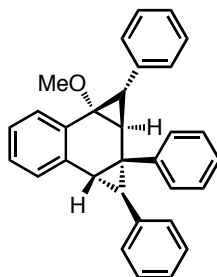

Tetracycle 74a. This compound was isolated as a minor product in the cyclization of enyne **44a**. White solid (8%). mp 75-77 °C.

¹H NMR (400 MHz, CDCl₃) δ 7.60 (d, *J* = 6.4 Hz, 1H), 7.53 (d, *J* = 5.6 Hz, 2H), 7.40 (t, *J* = 3.8 Hz, 1H), 7.39 (t, *J* = 6.4 Hz, 2H), 7.33 (dt, *J* = 6.0, 1.2 Hz, 1H), 7.27 (q, *J* = 4.5 Hz, 4H), 7.17 (q, *J* = 8.4 Hz, 3H), 7.11 (q, *J* = 4.5 Hz, 5H), 2.97 (d, *J* = 7.6 Hz, 1H), 2.86 (d, *J* = 7.6 Hz, 1H), 2.40 (d, *J* = 5.2 Hz, 1H), 2.32 (d, *J* = 5.2 Hz, 1H), 2.10 (s, 3H).

¹³C NMR (100 MHz, CDCl₃) δ 145.8 (C), 137.1 (C), 136.2 (C), 136.0 (C), 132.6 (C), 131.4 (CH), 130.4 (CH), 128.9 (CH), 128.58 (CH), 128.55 (CH), 127.9 (CH), 126.88 (CH), 126.85 (CH), 126.7 (CH), 126.5 (CH), 126.1 (CH), 125.9 (CH), 125.7 (CH), 67.7 (C), 53.0(OCH₃), 41.6 (CH), 39.4 (CH), 36.4 (C), 30.9 (CH), 28.9 (CH). HRMS-ESI calcd for C₃₁H₂₆O (M+Na)⁺: 437.1875; found: 437.1881. The relative configuration for this compound was assigned based on a NOESY experiment.

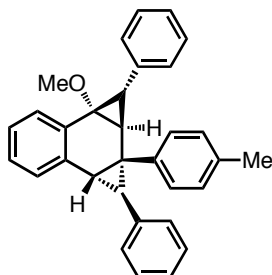

Tetracycle 74b. This compound was isolated as a minor product in the cyclization of enyne **44b**. Yellow oil (13%).

^1H NMR (400 MHz, CDCl_3) δ 7.55 (d, $J = 7.2$ Hz, 1H), 7.36 (t, $J = 6.4$ Hz, 3H), 7.27 (dt, $J = 7.6, 1.6$ Hz, 1H), 7.21 (dt, $J = 7.6, 1.6$ Hz, 1H), 7.15-7.03 (m, 10H), 2.89 (d, $J = 9.2$ Hz, 1H), 2.76 (d, $J = 9.2$ Hz, 1H), 2.35 (d, $J = 6.4$ Hz, 1H), 2.32 (s, 3H), 2.26 (d, $J = 6.4$ Hz, 1H), 2.05 (s, 3H).

^{13}C NMR (100 MHz, CDCl_3) δ 137.2 (C), 136.2 (C), 136.17 (C), 136.0 (C), 132.7 (C), 131.4 (CH), 130.4 (C), 129.5 (CH), 128.56 (CH), 128.52 (CH), 127.9 (CH), 126.8 (CH), 126.7 (CH), 126.6 (CH), 126.57 (CH), 126.56 (CH), 126.1 (CH), 125.7 (CH), 67.8 (C), 53.0 (OCH_3), 41.6 (CH), 39.4 (CH), 36.1 (C), 31.0 (CH), 28.9 (CH), 21.2 (CH_3). HRMS-ESI calcd for $\text{C}_{32}\text{H}_{28}\text{O}$ ($M+\text{Na}$) $^+$: 451.2016; found: 451.2038. The relative configuration for this compound was assigned based on a NOESY experiment.

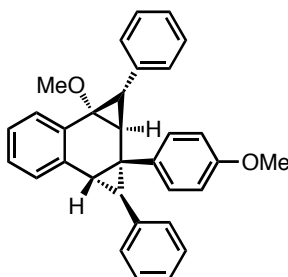

Tetracycle 74c. This compound was isolated as a minor product in the cyclization of enyne **44c**. Yellow oil (10%).

^1H NMR (400 MHz, CDCl_3) δ 7.55 (d, $J = 7.4$ Hz, 1H), 7.41 (d, $J = 8.8$ Hz, 2H), 7.35 (d, $J = 7.4$ Hz, 1H), 7.27 (dt, $J = 7.6, 1.4$ Hz, 1H), 7.21 (t, $J = 7.2$

Hz, 3H), 7.13 (t, $J = 7.6$ Hz, 4H), 7.06 (t, $J = 7.4$ Hz, 4H), 6.88 (d, $J = 8.8$ Hz, 2H), 3.79 (s, 3H), 2.92 (d, $J = 9.2$ Hz, 1H), 2.78 (d, $J = 9.2$ Hz, 1H), 2.36 (d, $J = 6.4$ Hz, 1H), 2.32 (d, $J = 6.4$ Hz, 1H), 2.05 (s, 3H).

^{13}C NMR (100 MHz, CDCl_3) δ 158.3 (C), 138.1 (C), 137.2 (C), 136.2 (C), 136.19 (C), 132.8 (C), 131.4 (CH), 130.4 (CH), 128.6 (CH), 128.5 (CH), 128.1 (CH), 127.9 (CH), 127.1 (CH), 126.8 (CH), 126.6 (CH), 126.1 (CH), 125.7 (CH), 115.2 (CH), 67.8 (C), 55.5 (OCH_3), 53.0 (OCH_3), 41.6 (CH), 39.1 (CH), 35.9 (C), 31.4 (CH), 28.7 (CH). HRMS-ESI calcd for $\text{C}_{32}\text{H}_{28}\text{O}_2$ ($M+\text{Na}$) $^+$: 467.1992; found: 467.1987. The relative configuration for this compound was assigned based on a NOESY experiment.

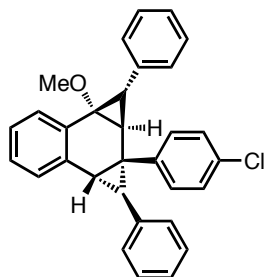

Tetracycle 74d. This compound was isolated as a minor product in the cyclization of enyne **44d**. Yellow solid (12%). mp 87-88 °C.

^1H NMR (400 MHz, CDCl_3) δ 7.55 (t, $J = 7.2$ Hz, 1H), 7.53 (t, $J = 7.4$ Hz, 1H), 7.42 (d, $J = 8.8$ Hz, 2H), 7.35 (t, $J = 7.2$ Hz, 1H), 7.32 (d, $J = 8.8$ Hz, 2H), 7.24 (t, $J = 7.2$ Hz, 3H), 7.13 (quint, $J = 8.4$ Hz, 4H), 7.06 (q, $J = 7.2$ Hz, 4H), 2.90 (d, $J = 9.2$ Hz, 1H), 2.78 (d, $J = 9.2$ Hz, 1H), 2.32 (d, $J = 6.4$ Hz, 1H), 2.25 (d, $J = 6.4$ Hz, 1H), 2.06 (s, 3H).

^{13}C NMR (100 MHz, CDCl_3) δ 144.3 (C), 136.8 (C), 136.4 (C), 135.7 (C), 132.2 (C), 131.7 (C), 131.4 (CH), 130.3 (CH), 128.9 (CH), 128.6 (CH), 128.5 (CH), 128.2 (CH), 128.1 (CH), 126.9 (CH), 126.88 (CH), 126.82 (CH), 126.3 (CH), 125.5 (CH), 67.7 (C), 53.1 (OCH_3), 41.6 (CH), 39.4 (CH), 35.9 (C), 30.7 (CH), 28.9 (CH). HRMS-ESI calcd for $\text{C}_{31}\text{H}_{25}\text{ClO}$ ($M+\text{Na}$) $^+$: 467.1992; found: 467.1987. The relative configuration for this compound was assigned based on a NOESY experiment.

Mechanistic studies. Scheme 2.16.

a) Cross-over cyclopropanation.

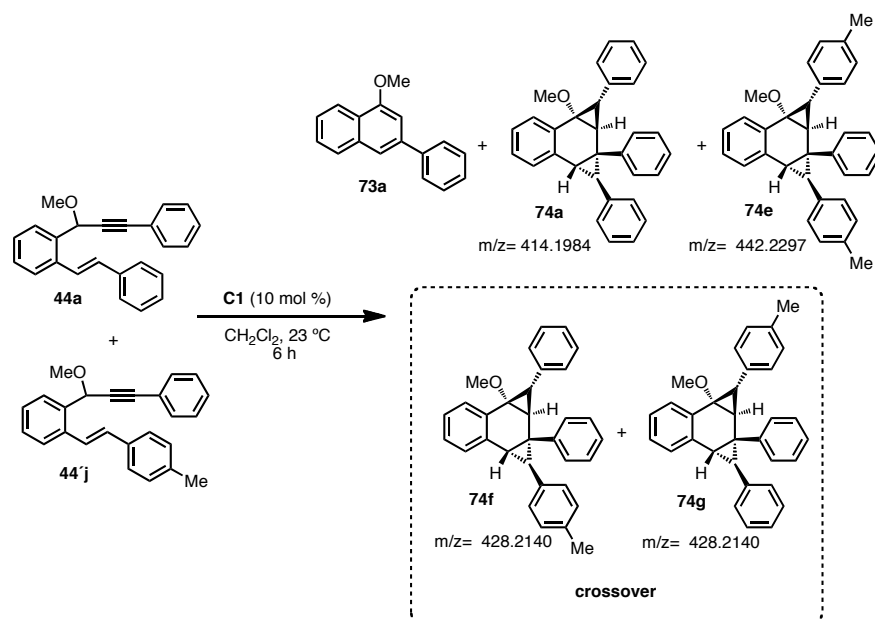

In a dry vial were dissolved enyne **44a** (81.04 mg, 0.25 mmol, 1 equiv) and enyne **44k** (84.5 mg, 0.25 mmol, 1 equiv) in CH_2Cl_2 (1 mL). Catalyst **C1** (19.3 mg, 0.025 mmol, 10 mol%) was added and the vial was closed. An intense red color was observed immediately. The mixture was stirred for 6 h at room temperature. The reaction was stopped by addition of three drops of triethylamine. The solvent was evaporated and the crude reaction mixture was analyzed as such, after it had been passed through a small silica gel bed. The analysis by HRMS-ESI ($M+\text{Na}$)⁺ confirms the formation of: 1) naphthalene **73a**, 2) tetracycle **74a** $\text{C}_{31}\text{H}_{26}\text{O}$ calcd 437.1881; found: 437.1888, 3) tetracycle **74e** $\text{C}_{33}\text{H}_{30}\text{O}$ calcd 465.2194; found: 465.2206, and 4) *cross-over products* **74f** and **74g** $\text{C}_{32}\text{H}_{28}\text{O}$ calcd 451.2038; found: 451.2044.

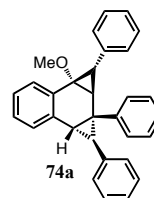

1 ppm MeOH
100119_SOAC_III_007 16 (0.680) Cm (9:16-55:60x5.000)

1: TOF MS ES+
3.34e+002

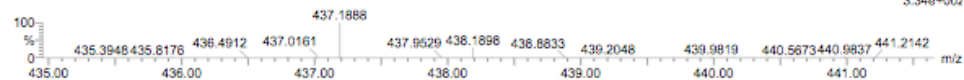

Minimum: -1.5
Maximum: 50.0

Mass	Calc. Mass	mDa	PPM	DBE	i-FIT	i-FIT (Norm)	Formula
437.1888	437.1881	0.7	1.6	18.5	17.4	0.4	C31 H26 O Na
	437.1870	1.8	4.1	-0.5	18.6	1.6	C15 H33 O14
	437.1905	-1.7	-3.9	21.5	19.2	2.2	C33 H25 O

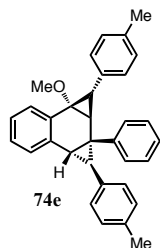

1 ppm MeOH
100119_SOAC_III_007 16 (0.680) Cm (9:16-55:60x5.000)

1: TOF MS ES+
1.17e+003

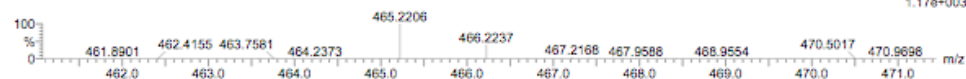

Minimum: -1.5
Maximum: 50.0

Mass	Calc. Mass	mDa	PPM	DBE	i-FIT	i-FIT (Norm)	Formula
465.2206	465.2194	1.2	2.6	18.5	35.1	0.3	C33 H30 O Na
	465.2218	-1.2	-2.6	21.5	36.3	1.5	C35 H29 O
	465.2229	-2.3	-4.9	6.5	37.6	2.8	C24 H35 O6 Na2

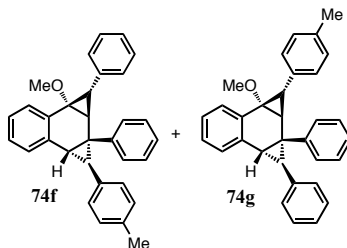

cross-over products

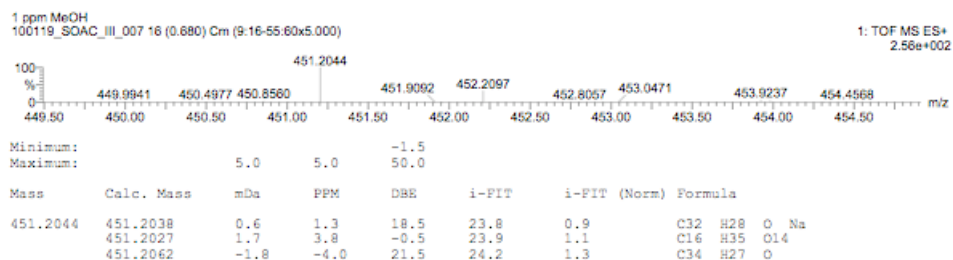

1-(1-Methoxy-3-phenylprop-2-yn-1-yl)-2-(4-methylstyryl)benzene (44k).

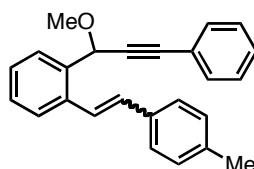

This compound was synthesized by methylation of (*E*)-1-(2-(4-methylstyryl)phenyl)-3-phenylprop-2-yn-1-ol according to general procedure C. The starting material was prepared starting from (*E*)-1-bromo-2-(4-methylstyryl)benzene and 3-phenylpropionaldehyde according to general procedure B. Yellow oil (62% overall, *Z/E* 5:1). Signals for major isomer.

^1H NMR (400 MHz, CDCl_3) δ 7.76 (d, $J = 6.0$ Hz, 1H), 7.46-7.43 (m, 1H), 7.40 (dd, $J = 6.4, 1.2$ Hz, 2H), 7.31-7.26 (m, 3H), 7.21-7.18 (m, 2H), 7.02 (d, $J = 6.8$ Hz, 2H), 6.95 (d, $J = 6.8$ Hz, 2H), 5.46 (s, 1H), 3.47 (s, 3H), 2.25 (s, 3H).

^{13}C NMR (100 MHz, CDCl_3) δ 137.35 (C), 137.21 (C), 136.68 (C), 133.90 (C), 131.96, 131.73, 129.77, 129.62 (C), 129.32, 129.02, 128.65, 128.56, 128.39, 127.74, 127.42, 126.83, 87.64 (C), 87.00 (C), 71.53, 56.61 (OCH_3), 21.36 (CH_3). HRMS-ESI calcd for $\text{C}_{25}\text{H}_{22}\text{O}$ ($M+\text{Na}$) $^+$: 361.1568; found: 361.1570.

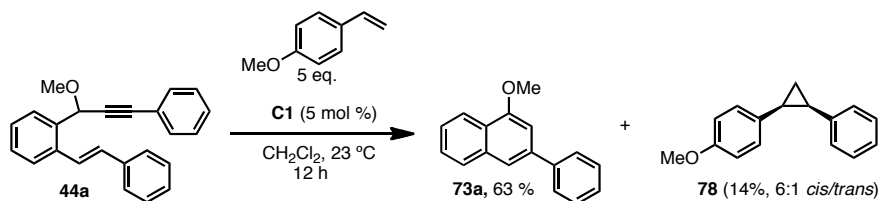
b) Trapping of free carbene from the cyclization of enyne (44a).

In a dry vial were dissolved enyne **44a** (162.1 mg, 0.50 mmol) and 1-methoxy-4-vinylbenzene (335.2 mg, 2.5 mmol, 5 equiv) in CH_2Cl_2 (2 mL). Catalyst **C1** (19.3 mg, 0.025 mmol, 5 mol%) was added and the vial was closed. An intense violet color was developed in few minutes. The mixture was stirred 12 h at room temperature. The reaction was stopped by addition of three drops of triethylamine. In order to remove excess of styrene, *p*-toluensulfonic acid (20 mg) was added and the crude reaction mixture was stirred for additional 20 min. The solvent was evaporated and the crude reaction mixture was purified by flash chromatography column to yield naphthalene **73a** (73.8 mg, 63%) and cyclopropane **78** (15.7 mg, 14%) as 6:1 *cis/trans* mixture. The spectroscopic data for cyclopropane matched with those reported in the literature.¹⁹

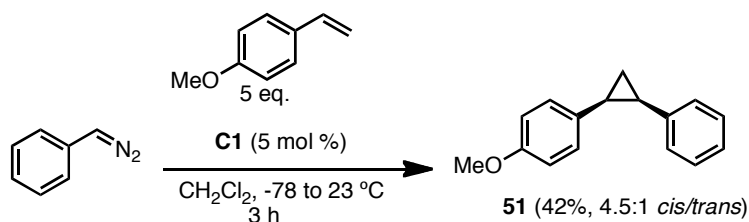
c) Cyclopropanation with phenyldiazomethane and catalyst (C1).

To a red solution of phenyldiazomethane²⁰ (59.0 mg, 0.5 mmol, 1 equiv) and 1-methoxy-4-vinylbenzene (335.2 mg, 2.5 mmol, 5 equiv) in CH_2Cl_2 (3 mL) at $-78\text{ }^\circ\text{C}$, was added catalyst **C1** (19.3 mg, 0.025 mmol, 5 mol%). The cooling bath was removed and the mixture allowed to warm up to room temperature. A vigorous N_2 evolution and disappearance of the red color were observed. The reaction was stirred 3 h at room temperature. The reaction was stopped by addition of three drops of triethylamine. In order to remove excess of styrene, *p*-

toluensulfonic acid (20 mg) was added and the crude reaction mixture was stirred for additional 20 min. The solvent was evaporated and the crude reaction mixture was purified by flash chromatography column to yield cyclopropane **51** (47.6 mg, 42%) as 4.5:1 *cis/trans* mixture.

Retro-cyclopropanation experiment. Scheme 2.18.

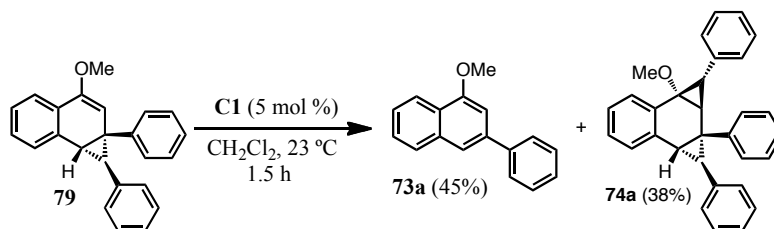

In a dry vial was dissolved enol-ether **79** (125.0 mg, 0.38 mmol) in CH_2Cl_2 (1 mL). Catalyst **C1** (14.7 mg, 0.019 mmol, 5 mol%) was added and the vial was closed. No change of color was observed. The mixture was stirred 1.5 h at room temperature. The reaction was stopped by addition of three drops of triethylamine. The solvent was evaporated and the crude reaction mixture was purified by flash chromatography to yield **73a** (40.0 mg, 45%) and **74a** (59.8 mg, 38%).

Synthesis of enol-ether (**79**).

(**1R**^{*},**1aS**^{*},**7bR**^{*})-3-Methoxy-1,1a-diphenyl-1a,7b-dihydro-1H-cyclopropa-
[a]naphthalene.

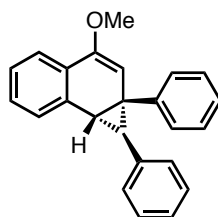

Ketone **69a** (310.1 mg, 1.0 mmol) was dissolved in MeOH (5 mL). Trimethylorthoformate (1.06 g, 10.0 mmol, 10 equiv) and *p*-TSA·H₂O (28.5 mg,

0.15 mmol, 15 mol%) were added and the mixture was heated for 1.5 h to 80 °C. The solvent was evaporated and the crude of reaction mixture was purified by flash chromatography to yield enol-ether **79** (210.7 mg, 65%) as yellow oil.

^1H NMR (400 MHz, CDCl_3) δ 7.50 (d, $J = 6.4$ Hz, 3H), 7.40 (q, $J = 7.6$ Hz, 3H), 7.31 (t, $J = 8.4$ Hz, 2H), 7.17 (dt, $J = 8.0, 0.8$ Hz, 1H), 7.04-7.01 (m, 3H), 6.94-6.90 (2H), 5.11 (s, 1H), 3.54 (s, 3H), 3.12 (d, $J = 10.0$ Hz, 1H), 3.05 (d, $J = 10.0$ Hz, 1H).

^{13}C NMR (100 MHz, CDCl_3) 150.9 (C), 146.6 (C), 135.8 (C), 133.7 (C), 131.8 (CH), 129.4 (C), 128.9 (CH), 128.8 (CH), 128.4 (CH), 127.9 (CH), 127.5 (CH), 126.8 (CH), 126.04 (CH), 126.0 (CH), 121.9 (CH), 98.2 (CH), 55.0 (OCH_3), 35.6 (C), 33.2 (CH), 23.8 (CH). HRMS-ESI calcd for $\text{C}_{24}\text{H}_{20}\text{O}$ ($M+\text{Na}$) $^+$: 324.1509; found: 324.1504.

9-Methoxy-6,7-diphenyl-5H-benzo[7]annulene (**80**).

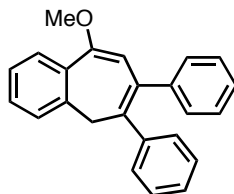

In a dry 50 mL flask was placed ketone **69a** (62 mg, 0.2 mmol) and was dissolved in 3 mL of DMSO. Sodium hydroxide (60 mg, 0.3 mmol) was added in pellets to the reaction mixture and the reaction is stirred by 2 h, then dimethyl sulfate (50.5 mg, 0.4 mmol, 0.38 mL) was added in one portion. The reaction is stirred by additional 40 min and is stopped by addition of 5 mL of $\text{NH}_4\text{Cl}_{(\text{sat})}$. The crude is extracted with EtOAc (3x5 mL), washed with water (3x 20 mL) and the organic phase dried over magnesium sulfate. The crude is purified by column to yield a dense yellow brown oil.

^1H NMR (400 MHz, CDCl_3) δ 8.39 – 8.24 (m, 1H), 7.90 – 7.75 (m, 1H), 7.49 – 7.36 (m, 2H), 7.37 – 7.29 (m, 5H), 7.23 – 7.14 (m, 2H), 7.14 – 7.07 (m, 1H), 7.04 – 6.95 (m, 2H), 6.79 (s, 1H), 4.34 (s, 2H), 4.00 (s, 3H).

^{13}C NMR (101 MHz, CDCl_3) δ 154.2, 143.0, 142.3, 140.5, 133.7, 129.4, 128.5, 128.3, 127.2, 127.1, 125.7, 125.7, 125.6, 125.0, 124.7, 122.5, 106.7, 55.7, 35.2.

Formal Synthesis of Macarpine.²¹ Scheme 2.20.

5-Methoxybenzo[*d*][1,3]dioxole (**S4**)¹⁴ and 5-bromo-6-styrylbenzo[*d*][1,3]dioxole **88**¹⁵ were synthesized according to the literature procedures.

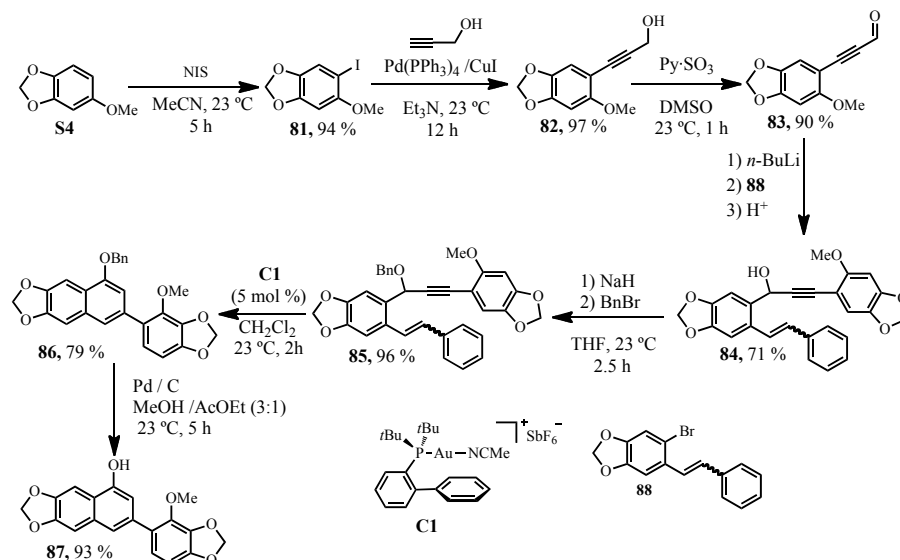

5-Iodo-6-methoxybenzo[*d*][1,3]dioxole (**81**).

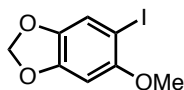

This compound was prepared by a modification of the reported procedure.²² Methyl sesamol **S4** (1.52 g, 10 mmol) was dissolved in acetonitrile (10 mL). Trifluoroacetic acid (0.11 mL, 1.50 mmol) was added and protected from light. *N*-iodosuccinimide (2.47 g, 11 mmol) dissolved in acetonitrile (10 mL) was added and the mixture was stirred at room temperature 5 h. The reaction was stopped by addition of $\text{Na}_2\text{S}_2\text{O}_3$ sat. and extracted with AcOEt (3x10 mL). The

combined organic extract was dried over MgSO_4 and evaporated. The residue was purified by flash chromatography to yield the desired compound (2.61 g, 94%) as brown-dark solid. mp 130-133 °C.

^1H NMR (400 MHz, CDCl_3) δ 7.17 (s, 1H), 6.52 (s, 1H), 5.94 (s, 2H), 3.81 (s, 3H).

^{13}C NMR (100 MHz, CDCl_3) δ 153.8 (C), 149.2 (C), 142.6 (C), 118.0 (CH), 101.9(CH₂), 95.2 (CH), 73.1 (C), 57.5 (OCH₃). GC-MS m/z 278 (M^+).

3-(6-Methoxybenzo[d][1,3]dioxol-5-yl)prop-2-yn-1-ol (**82**).

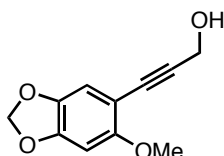

This compound was prepared in 97% yield according to the general procedure **D** starting from propargyl alcohol and iodide **81**. Cream solid. mp 102.5-103.5 °C.

^1H NMR (400 MHz, CDCl_3) δ 6.84(s, 1H), 6.50(s, 1H), 5.94(s, 2H), 4.52 (d, J = 4.5 Hz, 2H), 3.83 (s, 3H), 1.68 (t, J = 4.5 Hz, 1H).

^{13}C NMR (100 MHz, CDCl_3) δ 156.9 (C), 149.2 (C), 141.0 (C), 112.4 (CH), 103.4 (C), 101.8(CH₂), 94.7 (CH), 90.3 (C), 82.2 (C), 56.8(CH₂), 52.0 (OCH₃). HRMS-ESI calcd for $\text{C}_{11}\text{H}_{11}\text{O}_4$ ($\text{M}+\text{H}$)⁺: 207.0657; found: 207.0657.

3-(6-Methoxybenzo[d][1,3]dioxol-5-yl)propionaldehyde (**83**).

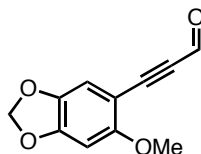

This compound was prepared in 90% yield according to the general procedure **E** by oxidation of propargyl alcohol **82**. Yellow bright solid. mp 150-150.5 °C.

^1H NMR (400 MHz, CDCl_3) δ 9.41 (s, 1H), 6.93 (s, 1H), 6.52 (s, 1H), 6.00 (s, 2H), 3.87 (s, 3H).

^{13}C NMR (100 MHz, CDCl_3) δ 176.8(CHO), 160.2 (C), 152.5 (C), 141.4 (C), 131.2 (CH), 102.4 (CH), 100.0 (C), 94.5(CH_2), 94.1 (C), 93.2 (C), 56.8 (OCH₃). HRMS-ESI calcd for $\text{C}_{11}\text{H}_8\text{O}_4$ ($M+\text{Na}^+$): 227.0320; found: 227.0314.

3-(6-Methoxybenzo[*d*][1,3]dioxol-5-yl)-1-(6-styrylbenzo[*d*][1,3]dioxol-5-yl)prop-2-yn-1-ol (84).

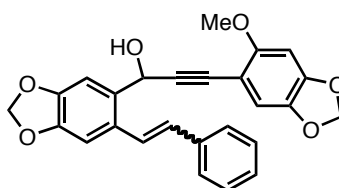

This compound was prepared in 71% yield according to the general procedure **B** starting from 5-bromo-6-styrylbenzo[*d*][1,3]dioxole **88** and 3-(6-methoxybenzo[*d*][1,3]dioxol-5-yl)propionaldehyde **83**. (*Z/E* 1:1.5). Beige solid mp 78-79 °C.

^1H NMR (400 MHz, CDCl_3) δ 7.61 (d, $J = 12.8$ Hz, 1H, *E*), 7.52 (d, $J = 6.0$ Hz, 2H, *E*), 7.44 (s, 1H, *E*), 7.43 (s, 1H, *Z*), 7.35 (t, $J = 6.0$ Hz, 2H, *E*), 7.21-7.14 (m, 6H, *Z*), 7.12 (s, 1H, *E*), 6.93 (d, $J = 12.8$ Hz, 1H, *E*), 6.83 (s, 1H, *Z*), 6.81 (s, 1H, *E*), 6.79 (s, 1H, *Z*), 6.67 (d, $J = 9.6$ Hz, 1H, *Z*), 6.61 (s, 1H, *Z*), 6.49 (s, 1H, *E*), 6.48 (s, 1H, *Z*), 5.99 (s, 2H, *E*), 5.96 (d, $J = 4.4$ Hz, 1H, *E*), 5.94 (s, 2H, *Z*), 5.93 (s, 2H, *E*), 5.92 (s, 2H, *Z*), 5.82 (d, $J = 4.0$ Hz, 1H, *Z*), 3.82 (s, 3H, *Z*), 3.80 (s, 3H, *E*), 2.24 (d, $J = 4.0$ Hz, 1H, *Z*), 2.12 (d, $J = 4.4$ Hz, 1H, *E*).

^{13}C NMR (100 MHz, CDCl_3) δ 157.4 (C, *E*), 157.3 (C, *Z*), 149.3 (C, *E*), 149.2 (C, *Z*), 148.11 (C, *E*), 147.6 (C, *E*), 147.5 (C, *Z*), 147.4 (C, *E*), 140.98 (C, *Z*), 140.96 (C, *E*), 137.6 (C, *Z*), 136.5 (C, *E*), 132.1 (C, *Z*), 132.4 (C, *Z*), 131.9 (CH, *E*), 130.6 (C, *Z*), 130.3 (CH, *E*), 129.4 (CH_2 , *Z*), 128.8 (CH_2 , *E*), 128.4 (CH_2 , *Z*), 127.9 (CH_2 , *E*), 127.8 (CH, *Z*), 127.5 (CH, *E*), 126.8 (CH, *Z*), 125.5 (C, *E*), 112.2 (CH, *Z*), 109.6 (CH, *E*), 108.3 (CH, *Z*), 106.2 (CH, *Z*), 103.4 (CH, *Z*), 103.3 (CH, *E*), 101.8 (CH_2 , *E*), 101.78 (CH_2 , *Z*), 101.5 (CH, *E*),

101.3 (CH₂, *Z*), 94.7 (CH₂, *E*), 91.7 (C, *Z*), 91.6 (C, *E*), 83.9 (C, *Z*), 83.2 (C, *E*), 63.0 (C, *E*), 62.9 (C, *Z*), 56.8 (OCH₃, *E*), 56.7 (OCH₃, *Z*). HRMS-ESI calcd for C₂₆H₂₀O₆ (*M*+Na)⁺: 451.1164; found: 451.1158.

5-(1-(Benzyloxy)-3-(6-methoxybenzo[*d*][1,3]dioxol-5-yl)prop-2-yn-1-yl)-6-styryl-benzo[*d*][1,3]dioxole (85).

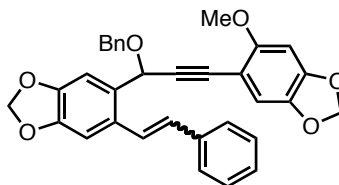

This compound was prepared in 96% yield by benzylation of 3-(6-methoxybenzo[*d*][1,3]dioxol-5-yl)-1-(6-styrylbenzo[*d*][1,3]dioxol-5-yl)prop-2-yn-1-ol **84**, according to the general procedure **C** using benzyl bromide instead of dimethyl sulfate. (*Z/E* 2:1). Brown solid, mp 110-112 °C.

¹H NMR (400 MHz, CDCl₃) δ 7.46 (s, 1H, *Z*), 7.45-7.42 (m, 3H, *E*), 7.38-7.33 (m, 1H, *E* + 3H, *Z*), 7.34- 7.27 (m, 4H, *E*, + 4H, *Z*), 7.21-7.13 (m, 4H, *E*, + 4H, *Z*), 7.11 (s, 1H, *E*), 6.87 (d, *J* = 12.8 Hz, 1H, *E*), 6.86 (s, 1H, *E*), 6.82 (s, 1H, *Z*), 6.62 (d, *J* = 9.6 Hz, 1H, *Z*), 6.58 (s, 1H, *E*), 6.52 (d, *J* = 9.6 Hz, 1H, *Z*), 6.50 (s, 1H, *Z*), 5.98 (dd, *J* = 4.0, 1.2 Hz, 2H, *E*), 3.94 (s, 3H, *Z*), 5.92 (dd, *J* = 6.0 Hz, 1.2 Hz, 2H, *E* + 1H, *Z*), 5.65 (s, 1H, *E*), 5.55 (s, 1H, *Z*), 4.80 (d, *J* = 1.2 Hz, 2H, *E*), 4.78 (d, *J* = 6.4 Hz, 1H, *Z*), 4.67 (d, *J* = 6.4 Hz, 1H, *Z*), 3.83 (s, 3H, *Z*), 3.81 (s, 3H, *E*).

¹³C NMR (100 MHz, CDCl₃) δ 157.6 (C, *E*), 157.5 (C, *Z*), 149.3 (C, *E*), 149.2 (C, *Z*), 148.2 (C, *E*), 147.7 (C, *Z*), 147.5 (C, *E*), 147.3 (C, *Z*), 141.0 (C, *Z*), 138.0 (C, *Z*), 137.9 (C, *E*), 137.7 (C, *E*), 136.7 (C, *Z*), 131.5 (CH, *Z*), 131.1 (C, *E*), 130.9 (C, *Z*), 130.5 (CH, *Z*), 130.0 (C, *E*), 129.4 (CH, *E*), 129.3 (CH, *Z*), 129.0 (CH, *E*), 128.8 (CH, *E*), 128.78 (CH, *Z*), 128.75 (CH, *E*), 128.67 (CH, *Z*), 128.65 (CH, *E*), 128.5 (CH, *Z*), 128.48 (CH, *E*), 128.3 (CH, *Z*), 128.0 (CH, *E*), 127.9 (CH, *E*), 127.7 (CH, *Z*), 127.4 (CH, *E*), 126.8 (CH, *Z*), 125.7 (CH, *E*), 112.2 (CH, *E*), 109.5 (CH, *Z*), 109.5 (CH, *E*), 108.9 (CH, *Z*), 105.9 (C, *Z*), 103.7 (C, *E*), 103.6 (C, *E*), 101.8 (CH₂, *E*), 101.79 (CH₂, *Z*), 101.5 (C,

Z), 101.3 (CH, Z), 94.86 (CH₂, E), 94.8 (CH₂, Z), 89.9 (C, Z), 89.7 (C, E), 85.3 (C, E), 84.5 (C, Z), 70.5 (CH₂, E), 70.2 (CH₂, E), 68.9 (CH₂, Z), 68.5 (CH₂, E), 56.9 (OCH₃, Z), 56.8 (OCH₃, E). HRMS-ESI calcd for C₃₃H₂₆O₆ (M+Na)⁺: 541.1641; found: 541.1627.

8'-(Benzyloxy)-5-methoxy-6,6'-binaphtho[2,3-*d*][1,3]dioxole (**86**).

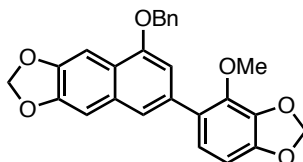

This compound was prepared by cyclization of enyne **85** according to the general procedure **F**, in 79% yield as brown needles. mp 144.5-146 °C.

¹H NMR (400 MHz, CDCl₃) δ 7.62 (s, 1H), 7.52 (d, *J* = 7.2 Hz, 2H), 7.42 (t, *J* = 6.8 Hz, 2H), 7.37-7.34 (m, 2H), 7.33 (bd, *J* = 1.2 Hz, 1H), 7.01 (s, 1H), 6.99 (d, *J* = 1.2 Hz, 1H), 6.89 (s, 1H), 6.64 (s, 1H), 6.03 (s, 2H), 5.97 (s, 2H), 5.24 (s, 2H), 3.69 (s, 3H).

¹³C NMR (101 MHz, CDCl₃) δ 153.6 (C), 152.1 (C), 148.2 (C), 147.6 (C), 147.4 (C), 141.7 (C), 137.6 (C), 135.1 (C), 131.7 (C), 128.8 (CH), 128.1 (CH), 127.6 (CH), 123.8 (CH), 121.3 (CH), 120.4 (CH), 110.7 (CH), 107.3 (CH), 104.2 (CH), 101.5(CH₂), 101.2(CH₂), 99.3 (C), 95.9 (CH), 70.4 (CH₂), 57.0 (OCH₃). HRMS-ESI calcd for C₂₆H₂₀O₆ (M+Na)⁺: 451.1172; found: 451.1158.

5'-Methoxy-[6,6'-binaphtho[2,3-*d*][1,3]dioxol]-8-ol (**87**).

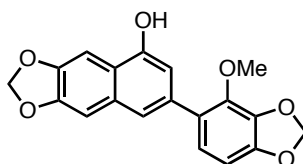

8'-(Benzyloxy)-5-methoxy-6,6'-binaphtho[2,3-*d*][1,3]dioxole **86** (42.8 mg, 0.10 mmol) was dissolved in a 3:1 solution of MeOH/AcOEt (2 mL). Pd/C 10% (10.1 mg, 0.01 mmol) was added and mixture was stirred at room temperature under H₂

atmosphere for 5 h. After filtering off the palladium catalyst, the solvent was evaporated and the residue purified by flash chromatography to yield **46l** (31.4 mg, 93%) as white needles. mp 178-180 °C (lit 178-179 °C).¹³

¹H NMR (400 MHz, CDCl₃) δ 7.46 (s, 1H), 7.31 (s, 1H), 7.09 (s, 1H), 6.88 (s, 2H), 6.64 (s, 1H), 6.03 (s, 2H), 5.96 (s, 2H), 5.16 (s, 1H), 3.73 (s, 3H).

¹³C NMR (101 MHz, CDCl₃) δ 152.03 (C), 150.46 (C), 148.31 (C), 147.63 (C), 147.35 (C), 141.76 (C), 135.11 (C), 132.11 (C), 123.29 (C), 120.46 (CH), 119.91 (C), 110.62 (CH), 110.24 (CH), 104.18 (CH), 101.51 (CH), 101.20 (CH), 98.68 (CH₂), 95.83 (CH₂), 57.08 (OCH₃). HRMS-ESI calcd for C₁₉H₁₄O₆ (*M*+Na)⁺: 361.0703; found: 361.0712.

1-Methoxy-2-methyl-4-(3-phenyl-1-(2-styrylphenyl)prop-2-yn-1-yl)benzene (**89a**).

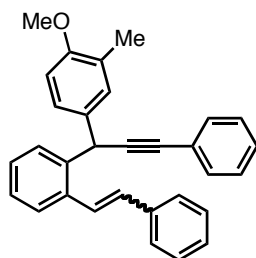

This compound was synthesized following the reported procedure.²² 3-Phenyl-1-(2-styrylphenyl)prop-2-yn-1-ol **44a** (155.0 mg, 0.5 mmol) and 1-methoxy-2-methylbenzene (122.1 mg, 1.0 mmol) were dissolved in acetonitrile (2 mL). Anhydrous FeCl₃ (4.0 mg, 0.025 mmol) was added and the mixture was stirred 10 min at room temperature. The mixture was filtered and the solvent was evaporated. The residue purified by flash chromatography to yield **89a** (190.5 mg, 92%) as a yellow oil. (8:1 *E/Z*). Signals for major *E* isomer.

¹H NMR (400 MHz, CDCl₃) δ 7.55 (d, *J* = 7.6 Hz, 1H), 7.41-7.38 (m, 2H), 7.28-7.23 (m, 5H), 7.13-7.07 (m, 8H), 6.76 (d, *J* = 12.4 Hz, 1H), 6.72 (d, *J* = 8.4 Hz, 1H), 6.65 (d, *J* = 12.4 Hz, 1H), 5.41 (s, 1H), 3.77 (s, 3H), 2.12 (s, 3H).

^{13}C NMR (100 MHz, CDCl_3) δ 156.8 (C), 140.4 (C), 136.8 (C), 136.7 (C), 132.7 (C), 131.9 (CH), 131.7 (C), 130.5 (CH), 129.9 (CH), 129.4 (CH), 129.1 (CH), 128.8 (CH), 128.3 (CH), 128.2 (CH), 128.0 (CH), 127.9 (CH), 127.4 (CH), 127.1 (CH), 126.8 (CH), 126.4 (CH), 123.9 (C), 110.0 (CH), 90.9 (C), 84.4 (C), 55.5 (OCH_3), 40.1 (CH), 16.5 (CH_3). HRMS-ESI calcd for $\text{C}_{31}\text{H}_{26}\text{O}$ ($M+\text{Na}$) $^+$: 437.1893; found: 437.1881.

1,2-Dimethoxy-4-(3-phenyl-1-(2-styrylphenyl)prop-2-yn-1-yl)benzene (**89b**).

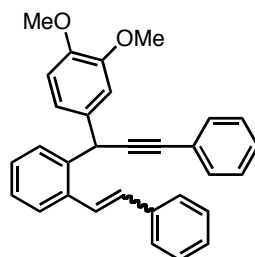

This compound was synthesized following the reported procedure.²² 3-Phenyl-1-(2-styrylphenyl)prop-2-yn-1-ol **44a** (155.0 mg, 0.5 mmol) and 1,2-dimethoxybenzene (103.5 mg, 0.75 mmol) were dissolved in acetonitrile (2 mL). Anhydrous FeCl_3 (4.0 mg, 0.025 mmol) was added and the mixture was stirred 10 min at room temperature. The mixture was filtered and the solvent was evaporated. The residue purified by flash chromatography to yield **89b** (178.5 mg, 83%) as a colorless oil. (83%, 6:1 *E/Z*). Signals for major *E* isomer. ^1H NMR (400 MHz, CDCl_3) δ 7.53 (d, $J = 7.6$ Hz, 1H), 7.42-7.38 (m, 2H), 7.28-7.22 (m, 5H), 7.17-7.06 (m, 6H), 6.98 (dd, $J = 7.6, 1.4$ Hz, 1H), 6.91 (d, $J = 1.2$ Hz, 1H), 6.82-6.78 (m, 1H), 6.77 (d, $J = 1.2$ Hz, 1H), 6.66 (d, $J = 12.4$ Hz, 1H).

^{13}C NMR (101 MHz, CDCl_3) δ 149.0 (C), 148.0 (C), 140.0 (C), 136.6 (CH), 133.6 (C), 131.7 (CH), 129.8 (CH), 129.2 (CH), 129.0 (CH), 128.8 (C), 128.7 (CH), 128.3 (CH), 128.2 (CH), 128.0 (CH), 127.99 (CH), 127.3 (CH), 127.2 (CH), 126.7 (C), 123.7 (C), 120.2 (CH), 111.5 (CH), 111.2 (CH), 90.6 (C), 84.6 (C), 56.0 (OCH_3), 55.8 (OCH_3), 40.4 (CH). HRMS-ESI calcd for $\text{C}_{31}\text{H}_{26}\text{O}_2$ ($M+\text{Na}$) $^+$: 453.1837; found: 453.1831.

1-(4-Methoxy-3-methylphenyl)-3-phenylnaphthalene (90a).

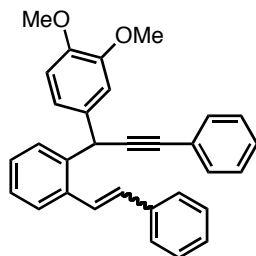

This compound was prepared by cyclization of enyne **89a** according to the general procedure **F**, in 66% yield as a clear amber oil.

^1H NMR (400 MHz, CDCl_3) δ 8.03 (d, $J = 1.2$ Hz, 1H), 7.95 (d, $J = 8.4$ Hz, 2H), 7.76 (d, $J = 7.2$ Hz, 2H), 7.69 (d, $J = 1.6$ Hz, 1H), 7.52-7.33 (m, 7H), 6.97 (d, $J = 8.0$ Hz, 1H), 3.93 (s, 3H), 2.32 (s, 3H).

^{13}C NMR (100 MHz, CDCl_3) δ 157.5 (C), 141.2 (C), 140.9 (C), 138.2 (C), 134.4 (C), 132.8 (C), 132.6 (CH), 131.3 (C), 129.0 (CH), 128.8 (CH), 128.6 (CH), 127.7 (CH), 127.6 (CH), 126.8 (CH), 126.7 (C), 126.3 (CH), 126.1 (CH), 125.2 (CH), 109.9 (CH), 55.7 (OCH_3), 16.6 (CH_3). HRMS-ESI calcd for $\text{C}_{24}\text{H}_{20}\text{O}$ ($M+\text{H}$) $^+$: 325.1595; found: 325.1592.

1-(3,4-Dimethoxyphenyl)-3-phenylnaphthalene (90b).

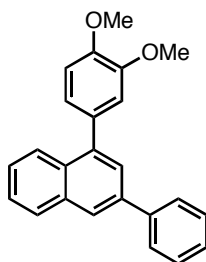

This compound was prepared by cyclization of enyne **89b** according to the general procedure **F**, in 74% yield as a clear yellow oil.

^1H NMR (400 MHz, CDCl_3) δ 8.06 (bs, 1H), 7.96 (dd, $J = 8.4, 4.4$ Hz, 2H), 7.77 (d, $J = 7.6$ Hz, 2H), 7.72 (d, $J = 2.0$ Hz, 1H), 7.55-7.47 (m, 3H), 7.46-

7.36 (m, 2H), 7.10 (td, $J = 6.8, 1.6$ Hz, 2H), 7.03 (d, $J = 8.0$ Hz, 1H), 3.98 (s, 3H), 3.91 (s, 3H).

^{13}C NMR (100 MHz, CDCl_3) δ 148.9 (C), 148.7 (C), 141.1 (C), 140.8 (C), 138.2 (C), 134.4 (C), 133.6 (C), 131.3 (C), 129.1 (CH), 128.8 (CH), 127.7(CH \times 2), 126.8 (CH), 126.4 (CH), 126.3 (CH), 126.2 (CH), 125.4 (CH), 122.5 (CH), 113.6 (CH), 111.3 (CH), 56.24 (OCH $_3$), 56.21 (OCH $_3$). HRMS-ESI calcd for $\text{C}_{24}\text{H}_{20}\text{O}_2$ ($M+\text{Na}$) $^+$: 363.1379; found: 363.1361.

Enynes 45a-j. Scheme 7.

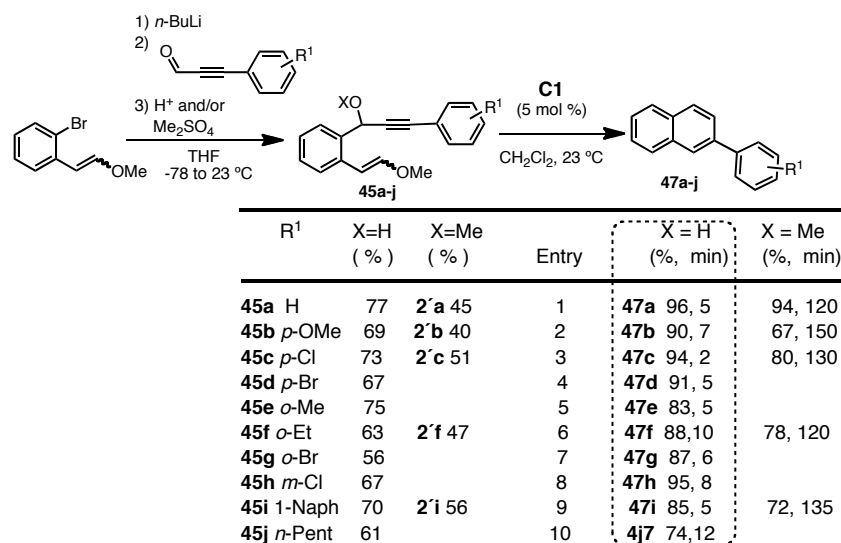
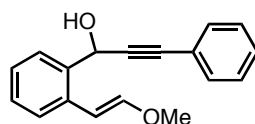

Table for annulation/fragmentation of enynes **45a-45j**. Better yields and shorter reaction times were observed for the cyclization of free propargyl alcohols (compare entries 1-3, 6 and 9).

(*E*)-1-(2-(2-Methoxyvinyl)phenyl)-3-phenylprop-2-yn-1-ol (**45a**).



This compound was prepared according to the general procedure **B** starting from 1-bromo-2-(2-methoxyvinyl)benzene **91** and 3-phenylpropionaldehyde **60**. Yellow oil (77%).

^1H NMR (400 MHz, CDCl_3) δ 7.82 (dd, $J = 8.0, 1.2$ Hz, 1H), 7.75 (dd, $J = 8.0, 1.2$ Hz, 1H), 7.47-7.45 (m, 2H), 7.32-7.28 (m, 4H), 7.27-7.21 (m, 1H), 6.24 (d, $J = 7.2$ Hz, 1H), 5.87 (s, 1H), 5.67 (d, $J = 7.2$ Hz, 1H), 3.74 (s, 3H), 2.53 (bs, 1H).

^{13}C NMR (100 MHz, CDCl_3) δ 148.8 (CH), 137.2 (C), 133.6 (C), 131.9 (CH), 130.1 (CH), 128.6 (CH), 128.5 (CH), 128.4 (CH), 127.2 (CH), 126.7 (CH), 122.9 (C), 102.0 (CH), 88.9 (C), 86.8 (C), 63.5 (CH_3), 60.8 (CH). HRMS-ESI calcd for $\text{C}_{18}\text{H}_{16}\text{O}_2$ ($M+\text{Na}$) $^+$: 287.1038; found: 287.1048.

(E)-1-(3-Methoxy-3-(2-(2-methoxyvinyl)phenyl)prop-1-ynyl)benzene (45'a).

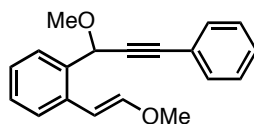

This compound was prepared by methylation of 1-(2-(2-methoxyvinyl)phenyl)-3-phenylprop-2-yn-1-ol (**45a**), according to the general procedure **C**. Colorless oil (45%).

^1H NMR (400 MHz, CDCl_3) δ 7.67 (dd, $J = 7.4, 1.6$ Hz, 1H), 7.47 (dd, $J = 8.0, 1.6$ Hz, 2H), 7.34-7.28 (m, 4H), 7.26-7.20 (m, 2H), 6.92 (d, $J = 13.2$ Hz, 1H), 6.22 (d, $J = 13.2$ Hz, 1H), 5.44 (s, 1H), 3.72 (s, 3H), 3.50 (s, 3H).

^{13}C NMR (100 MHz, CDCl_3) δ 150.4 (CH), 135.5 (C), 134.9 (C), 131.9 (CH), 128.9 (CH), 128.6 (CH), 128.5 (CH), 128.4 (CH), 126.3 (CH), 126.28 (CH), 122.8 (C), 102.3 (CH), 88.1 (C), 86.8 (C), 71.9 (CH), 56.7 (CH_3), 56.1 (CH_3). HRMS-ESI calcd for $\text{C}_{19}\text{H}_{18}\text{O}_2$ ($M+\text{Na}$) $^+$: 301.1204; found: 301.1201.

3-(4-Methoxyphenyl)-1-(2-(2-methoxyvinyl)phenyl)prop-2-yn-1-ol (45b).

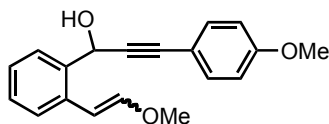

This compound was prepared according to the general procedure **B** starting from 1-bromo-2-(2-methoxyvinyl)benzene **91** and 3-(4-methoxyphenyl) propiolaldehyde **61**. Brown oil (69%, 1:1 *E/Z*).

^1H NMR (400 MHz, CDCl_3) δ 7.82 (d, $J = 8.0$ Hz, 1H, *E*), 7.76 (dd, $J = 8.0$, 1.6 Hz, 1H, *Z*), 7.72 (dd, $J = 8.0$, 1.6 Hz, 1H, *E*), 7.40 (dd, $J = 8.8$, 2.8 Hz, 4H, *E+Z*), 7.34-7.21 (m, 3H, *E+Z*), 7.25-7.20 (m, 2H, *E+Z*), 6.93 (d, $J = 12.8$ Hz, 1H, *E*), 6.84 (dd, $J = 8.8$, 2.8 Hz, 4H, *E+Z*), 6.30 (d, $J = 12.8$ Hz, 1H, *E*), 6.26 (d, $J = 7.2$ Hz, 1H, *Z*), 5.87 (d, $J = 5.8$ Hz, 1H, *E*), 5.84 (d, $J = 5.8$ Hz, 1H, *Z*), 5.68 (d, $J = 7.2$ Hz, 1H, *Z*), 3.81 (s, 6H, *E+Z*), 3.76 (s, 3H, *E*), 3.73 (3H, *Z*), 2.38 (d, $J = 5.8$ Hz, 1H, *E*), 2.22 (d, $J = 5.8$ Hz, 1H, *E*).

^{13}C NMR (100 MHz, CDCl_3) δ 159.9(C, *E*), 159.8(C, *Z*), 150.6 (CH), 148.7 (CH), 137.4 (C), 137.2 (C), 135.1 (C), 133.6 (C), 133.4 (CH), 133.3 (CH), 130.1 (CH), 128.8 (CH), 128.4 (CH), 127.4 (CH), 127.2 (CH), 126.6 (CH), 126.5 (CH), 126.49 (CH), 114.9 (C), 114.8 (C), 114.12 (CH), 114.07 (CH), 102.08 (CH), 102.02 (CH), 87.5(C, *E*), 87.4(C, *Z*), 87.0(C, *E*), 86.7(C, *Z*), 63.53 (CH), 63.5 (CH), 60.8 (CH_3 , *E*), 56.7 (CH_3 , *Z*), 55.4 (CH_3 , *E+Z*). HRMS-ESI calcd for $\text{C}_{19}\text{H}_{18}\text{O}_3$ ($M+\text{Na}$) $^+$: 317.1162; found: 317.1154.

1-(1-Methoxy-3-(4-methoxyphenyl)prop-2-ynyl)-2-(2-methoxyvinyl)benzene (45'b).

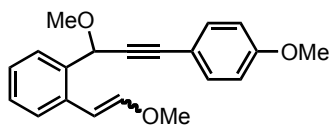

This compound was prepared by methylation of 3-(4-methoxyphenyl)-1-(2-(2-methoxyvinyl)phenyl)prop-2-yn-1-ol (**45b**), according to the general procedure **C**. Colorless oil (40%, 2:1 *Z/E*).

^1H NMR (400 MHz, CDCl_3) δ 7.93 (dd, $J = 7.8$, 1.2 Hz, 1H, *Z*), 7.67 (dd, $J = 7.8$, 1.2 Hz, 1H, *Z* + 1H, *E*), 7.44 (d, $J = 8.8$ Hz, 1H, *E*), 7.40 (d, $J = 8.8$ Hz,

2H, *Z* + 2H, *E*), 7.30 (q, $J = 7.4$ Hz, 1H, *Z* + 1H, *E*), 7.21 (dq, $J = 7.4$, 1.6 Hz, 1H, *Z* + 1H, *E*), 6.92 (d, $J = 12.8$ Hz, 1H, *E*), 6.86-6.81 (m, 2H, *Z* + 2H, *E*), 6.24 (d, $J = 7.4$ Hz, 1H, *Z*), 6.23 (d, $J = 12.8$ Hz, 1H, *E*), 5.62 (d, $J = 7.4$ Hz, 1H, *Z*), 5.45 (bs, 1H, *Z*), 5.42 (bs, 1H, *E*), 3.81 (s, 6H, *E* + *Z*), 3.76 (s, 3H, *Z*), 3.72 (s, 3H, *E*), 3.49 (s, 3H, *E*), 3.45 (s, 3H, *Z*).

^{13}C NMR (100 MHz, CDCl_3) δ 159.8 (CH, *E*), 150.3 (CH, *Z*), 148.6 (C, *E*+*Z*), 135.5 (C, *E*+*Z*), 135.1 (C, *E*), 134.9 (C, *Z*), 134.2 (C, *Z*), 133.6 (C, *E*), 133.4 (CH, *E*+*Z*), 129.9 (CH, *E*+*Z*), 128.8 (C, *Z*), 128.4 (CH, *E*+*Z*), 128.0 (CH, *E*+*Z*), 126.2 (CH, *E*+*Z*), 115.1 (CH, *E*+*Z*), 114.1 (CH, *Z*), 102.4 (CH, *E*), 101.9 (CH, *Z*), 88.1 (C, *E*), 87.8 (C, *Z*), 85.5 (C, *Z*), 85.4 (C, *E*), 71.9 (CH, *E*), 71.8 (CH, *Z*), 61.2 (OCH_3 , *Z*), 56.7 (OCH_3 , *E*), 56.1 (OCH_3 , *E*), 56.0 (OCH_3 , *Z*), 55.5 (OCH_3 , *E*+*Z*). HRMS-APCI calcd for $\text{C}_{19}\text{H}_{17}\text{O}_2$ (M-Ome) $^+$: 277.1217; found: 277.1229.

3-(4-Chlorophenyl)-1-(2-(2-methoxyvinyl)phenyl)prop-2-yn-1-ol (45c).

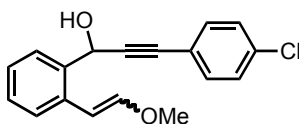

This compound was prepared according to the general procedure **B** starting from 1-bromo-2-(2-methoxyvinyl)benzene **91** and 3-(4-chlorophenyl)propionaldehyde **62**. Yellow dark oil (73%, 1:1 *E*/*Z*).

^1H NMR (400 MHz, CDCl_3) δ 7.81 (d, $J = 8.0$ Hz, 1H, *E*), 7.73 (dd, $J = 8.0$, 1.6 Hz, 1H, *Z*), 7.69 (dd, $J = 8.0$, 1.6 Hz, 1H, *E*), 7.40 (d, $J = 8.0$ Hz, 2H, *Z*), 7.37 (d, $J = 8.0$ Hz, 2H, *E*), 7.35-7.31 (m, 2H, *E*+*Z*), 7.29 (d, $J = 8.0$ Hz, 2H, *E*), 7.27 (d, $J = 8.0$ Hz, 2H, *Z*), 7.25-7.21 (m, 3H, *E*+*Z*), 6.93 (d, $J = 12.8$ Hz, 1H, *E*), 6.28 (d, $J = 6.0$ Hz, 1H, *Z*), 6.26 (d, $J = 12.8$ Hz, 1H, *E*), 5.84 (d, $J = 5.2$ Hz, 1H, *E*), 5.85 (d, $J = 5.2$ Hz, 1H, *Z*), 5.65 (d, $J = 6.8$ Hz, 1H, *Z*), 3.76 (s, 3H, *Z*), 3.73 (s, 3H, *E*), 2.42 (d, $J = 5.2$ Hz, 1H, *E*), 2.23 (d, $J = 5.2$ Hz, 1H, *Z*).

^{13}C NMR (100 MHz, CDCl_3) δ 150.7 (CH), 148.8 (CH), 136.9 (C), 136.7 (C), 135.0 (CH), 134.7 (C), 134.6 (C), 133.5 (CH), 133.1 (CH), 133.0 (CH), 130.1

(CH), 128.9 (CH), 128.8 (CH), 128.7 (CH), 128.6 (CH), 127.3 (C), 127.2 (C), 126.7 (CH), 126.6(CHx2), 121.3 (C), 121.2 (C), 101.98 (CH), 101.93 (CH), 89.9 (C), 89.8 (C), 85.8 (C), 85.6 (C), 63.4 (CHx2), 60.8 (CH₃), 56.8 (CH₃). HRMS-ESI calcd for C₁₈H₁₅O₂ (M+Na)⁺: 321.0647; found: 321.0658.

1-Chloro-4-(3-methoxy-3-(2-(2-methoxyvinyl)phenyl)prop-1-ynyl)benzene (45'c).

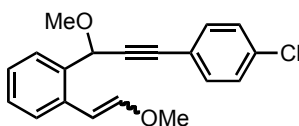

This compound was prepared by methylation of 3-(4-chlorophenyl)-1-(2-(2-methoxyvinyl)phenyl)prop-2-yn-1-ol (**45c**), according to the general procedure C. Brown oil (51%, 1:1 *E/Z*).

¹H NMR (400 MHz, CDCl₃) δ 7.92 (dd, *J* = 8.0, 1.6 Hz, 1H, *E*), 7.63 (dt, *J* = 7.6, 1.2 Hz, 2H, *E+Z*), 7.39 (d, *J* = 8.4 Hz, 4H, *E+Z*), 7.34-7.18 (m, 9H, *E+Z*), 6.91 (d, *J* = 12.8 Hz, 1H, *E*), 6.24 (d, *J* = 7.2 Hz, 1H, *Z*), 6.20 (d, *J* = 12.8 Hz, 1H, *E*), 5.60 (d, *J* = 7.2 Hz, 1H, *E*), 5.45 (s, 1H, *Z*), 5.41 (s, 1H, *E*), 3.76 (s, 3H, *E*), 3.72 (s, 3H, *Z*), 3.49 (s, 3H, *E*), 3.45 (s, 3H, *Z*).

¹³C NMR (100 MHz, CDCl₃) δ 150.5 (CH), 148.7 (CH), 135.5 (C), 134.7 (C), 134.67 (C), 134.6 (C), 134.5 (C), 134.2 (C), 133.2 (CH), 133.17(CHx2), 130.0 (CH), 128.9 (CH), 128.8 (CH), 128.7 (CH), 128.5 (CH), 128.3 (CH), 127.9 (CH), 126.3 (CH), 126.28 (CH), 121.4 (C), 121.3 (C), 102.3 (CH), 101.7 (CH), 88.1 (C), 87.9 (C), 86.9 (C), 86.6 (C), 71.9 (CH), 71.7 (CH), 60.8 (CH₃), 56.8 (CH₃), 56.2 (CH₃), 56.19 (CH₃). HRMS-ESI calcd for C₁₉H₁₇ClO₂ (M+Na)⁺: 335.0823; found: 335.0815.

3-(4-Bromophenyl)-1-(2-(2-methoxyvinyl)phenyl)prop-2-yn-1-ol (45d).

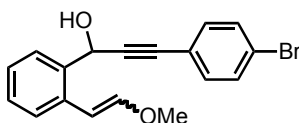

This compound was prepared according to the general procedure **B** starting from 1-bromo-2-(2-methoxyvinyl)benzene **91** and 3-(4-bromophenyl)propionaldehyde **64**. Red oil (67%, 1:1 *E/Z*).

^1H NMR (400 MHz, CDCl_3) δ 7.81 (d, $J = 8.0$ Hz, 1H, *E*), 7.72 (dd, $J = 8.0$, 1.6 Hz, 1H, *Z*), 7.68 (dd, $J = 8.0$, 1.6 Hz, 1H, *E*), 7.45 (d, $J = 8.0$ Hz, 2H, *Z*), 7.43 (d, $J = 8.0$ Hz, 2H, *E*), 7.34-7.33 (m, 2H, *E+Z*), 7.32 (d, $J = 8.0$ Hz, 2H, *E*), 7.30 (d, $J = 8.0$ Hz, 2H, *Z*), 7.28-7.21 (m, 3H, *E+Z*), 6.92 (d, $J = 12.8$ Hz, 1H, *E*), 6.27 (d, $J = 6.8$ Hz, 1H, *Z*), 6.25 (d, $J = 12.8$ Hz, 1H, *E*), 5.84 (d, 5.2 Hz, 1H, *E*), 5.84 (d, 5.2 Hz, 1H, *Z*), 5.65 (d, $J = 6.8$ Hz, 1H, *Z*), 3.75 (s, 3H, *E*), 3.72 (s, 3H, *Z*), 2.41 (bs, 2H).

^{13}C NMR (100 MHz, CDCl_3) δ 150.7 (CH), 148.8 (CH), 136.9 (C), 136.7 (C), 135.0 (C), 133.5 (C), 133.3 (CH), 133.28 (CH), 131.7 (CH), 131.68 (CH), 130.1 (CH), 128.9 (CH), 128.6 (CH), 127.3 (CH), 127.2 (CH), 126.7 (CH), 126.56 (CH), 126.5 (CH), 122.9 (C), 122.8 (C), 121.8 (C), 121.6 (C), 101.98 (CH), 101.9 (CH), 90.14 (C), 90.0 (C), 85.9 (C), 85.6 (C), 63.4 (CH_{x2}), 60.8 (CH₃), 56.7 (CH₃). HRMS-ESI calcd for $\text{C}_{18}\text{H}_{15}\text{BrO}_2$ ($M+\text{Na}$)⁺: 365.0141; found: 365.0153.

1-(2-(2-Methoxyvinyl)phenyl)-3-*o*-tolylprop-2-yn-1-ol (**45e**).

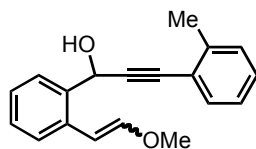

This compound was prepared according to the general procedure **B** starting from 1-bromo-2-(2-methoxyvinyl)benzene **91** and 3-(*o*-tolyl)propionaldehyde **66**. Brown oil (75%, 1:1 *E/Z*).

^1H NMR (400 MHz, CDCl_3) δ 7.83 (d, $J = 8.0$ Hz, 1H, *E*), 7.78 (dd, $J = 8.0$, 1.6 Hz, 1H, *Z*), 7.75 (dd, $J = 8.0$, 1.6 Hz, 1H, *E*), 7.44 (dt, $J = 7.6$, 1.2 Hz, 2H, *E+Z*), 7.35-7.28 (m, 4H, *E+Z*), 7.25-7.08 (m, 7H, *E+Z*), 6.94 (d, $J = 12.8$ Hz, 1H, *E*), 6.31 (d, $J = 12.8$ Hz, 1H, *E*), 6.26 (d, $J = 7.2$ Hz, 1H, *Z*), 5.92 (s, 1H, *E*), 5.89 (s, 1H, *Z*), 5.70 (d, $J = 7.2$ Hz, 1H, *Z*), 3.76 (s, 3H, *E*), 3.73 (s, 3H, *Z*), 2.44 (s, 6H, *E+Z*), 1.54 (bs, 2H).

^{13}C NMR (100 MHz, CDCl_3) δ 150.6 (CH), 148.7 (CH), 140.5 (C), 140.4 (C), 137.3 (C), 137.1 (C), 134.9 (C), 133.5 (C), 132.23 (CH), 132.22 (CH), 130.0 (CH), 129.6 (CH), 129.5 (CH), 128.8 (CH), 128.6 (CH), 128.57 (CH), 128.4 (CH), 127.2 (CH), 127.1 (CH), 126.5 (CH), 126.46 (CH), 126.4 (CH), 125.66 (CH), 125.6 (CH), 122.6 (C), 122.5 (C), 102.0 (CH), 101.9 (CH), 92.8 (C), 92.7 (C), 85.9 (C), 85.7 (C), 63.48 (CH), 63.4 (CH), 60.7 (CH_3), 56.6 (CH_3), 20.9 (CH_3), 20.87 (CH_3). HRMS-ESI calcd for $\text{C}_{19}\text{H}_{18}\text{O}_2$ ($M+\text{Na}$) $^+$: 301.1209; found: 301.1204.

3-(2-Ethylphenyl)-1-(2-(2-methoxyvinyl)phenyl)prop-2-yn-1-ol (45f).

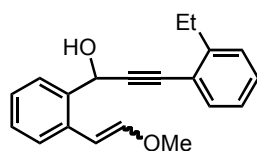

This compound was prepared according to the general procedure **B** starting from 1-bromo-2-(2-methoxyvinyl)benzene **91** and 3-(2-ethylphenyl)propiolaldehyde **67**. Yellow oil (63%, 1:1 *E/Z*).

^1H NMR (400 MHz, CDCl_3) δ 7.90 (dd, $J = 8.0, 1.2$ Hz, 1H, *E*), 7.83 (dd, $J = 8.0, 1.2$ Hz, 1H, *Z*), 7.80 (dd, $J = 7.2, 2.0$ Hz, 1H, *E*), 7.50 (dt, $J = 7.6, 1.6$ Hz, 2H, *E+Z*), 7.39-7.25 (m, 11H, *E+Z*), 7.19 (tt, $J = 7.2, 2.0$ Hz, 2H, *E+Z*), 6.99 (d, $J = 12.8$ Hz, 1H, *E*), 6.35 (d, $J = 12.8$ Hz, 1H, *E*), 6.31 (d, $J = 7.2$ Hz, 1H, *Z*), 5.97 (s, 1H, *E*), 5.95 (s, 1H, *Z*), 5.75 (d, $J = 7.2$ Hz, 1H, *Z*), 3.81 (s, 3H, *E*), 3.78 (s, 3H, *Z*), 2.86 (q, $J = 7.6$ Hz, 4H, *E+Z*), 1.27 (t, $J = 7.6$ Hz, 6H, *E+Z*).

^{13}C NMR (100 MHz, CDCl_3) δ 150.6 (CH), 148.7 (CH), 146.5 (C), 146.4 (C), 137.2 (C), 137.1 (C), 134.9 (C), 133.5 (C), 132.54 (CH), 132.5 (CH), 130.0 (CH), 128.9 (CH), 128.8 (CH), 128.7 (CH), 128.3 (CH), 128.04 (CH), 128.02 (CH), 127.2 (CH), 127.1 (CH), 125.6 (CH), 126.4 (CH), 126.37 (CH), 125.7 (CH), 125.67 (CH), 121.9 (C), 121.7 (C), 101.98 (CH, *E*), 101.9 (CH, *Z*), 92.4 (C, *E*), 92.2 (C, *Z*), 85.7 (C, *E*), 85.4 (C, *Z*), 63.4 (CH), 63.3 (CH), 60.7 (CH_3), 56.6 (CH_3), 27.8 ($\text{CH}_2 \times 2$), 15.04 (CH_3), 15.0 (CH_3). HRMS-ESI calcd for $\text{C}_{20}\text{H}_{20}\text{O}_2$ ($M+\text{Na}$) $^+$: 315.1366; found: 315.1361.

1-(3-(2-Ethylphenyl)-1-methoxyprop-2-ynyl)-2-(2-methoxyvinyl)benzene (45'f).

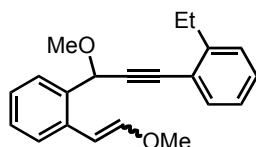

This compound was prepared by methylation of 3-(2-ethylphenyl)-1-(2-(2-methoxyvinyl)phenyl)prop-2-yn-1-ol (**45f**), according to the general procedure **C**. Amber oil (47%, 1:1 *E/Z*).

^1H NMR (400 MHz, CDCl_3) δ 7.94 (dd, $J = 7.4, 1.6$ Hz, 1H, *E*), 7.70 (dd, $J = 8.0, 1.6$ Hz, 2H, *E+Z*), 7.45 (dd, $J = 7.4, 1.2$ Hz, 2H, *E+Z*), 7.34-7.27 (m, 3H, *E+Z*), 7.25-7.17 (m, 6H, *E+Z*), 7.16-7.11 (m, 2H, *E+Z*), 6.92 (d, $J = 12.8$ Hz, 1H, *E*), 6.24 (d, $J = 7.2$ Hz, 1H, *Z*), 6.21 (d, $J = 12.8$ Hz, 1H, *E*), 5.63 (d, $J = 7.2$ Hz, 1H, *Z*), 5.53 (s, 1H, *E*), 5.50 (s, 1H, *Z*), 3.76 (s, 3H, *E*), 3.72 (s, 3H, *Z*), 3.52 (s, 3H, *E*), 3.49 (s, 3H, *Z*), 2.81 (q, $J = 2.4$ Hz, 4H, *E+Z*), 1.21 (t, $J = 2.4$ Hz, 6H, *E+Z*).

^{13}C NMR (100 MHz, CDCl_3) δ 150.4 (CH), 148.6 (CH), 146.6 (C), 146.5 (C), 135.5 (C), 135.0 (C), 134.8 (C), 134.2 (C), 132.7(CH_x3), 130.0 (CH), 128.9 (CH), 128.8 (CH), 128.4 (CH), 128.3 (CH), 128.1(CH_x2), 128.0 (CH), 126.3 (CH), 126.28 (CH), 126.27 (CH), 125.8 (CH), 125.7 (CH), 122.0 (C), 121.9 (C), 102.3 (CH), 101.8 (CH), 90.4 (C), 90.2 (C), 86.9 (C), 86.7 (C), 71.9 (CH), 71.8 (CH), 60.8 (CH₃), 56.7 (CH₃), 56.04 (CH₃), 56.01 (CH₃), 27.9 (CH₂x2), 15.16 (CH₃), 15.13 (CH₃). HRMS-ESI calcd for $\text{C}_{21}\text{H}_{22}\text{O}_2$ ($M+\text{Na}$)⁺: 329.1517; found: 329.1510.

3-(2-Bromophenyl)-1-(2-(2-methoxyvinyl)phenyl)prop-2-yn-1-ol (45g).

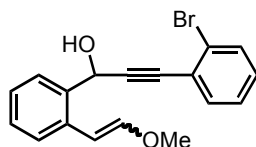

This compound was prepared according to the general procedure **B** starting from 1-bromo-2-(2-methoxyvinyl)benzene **91** and 3-(2-bromophenyl)propionaldehyde **68**. Red oil (56%, 3.3:1 *Z/E*).

¹H NMR (400 MHz, CDCl₃) δ 7.84 (dt, $J = 7.0, 1.2$ Hz, 2H, *Z* + 1H, *E*), 7.58 (d, $J = 8.0$ Hz, 1H, *Z* + 1H, *E*), 7.49 (dd, $J = 7.5, 2.0$ Hz, 1H, *Z* + 1H, *E*), 7.32 (dt, $J = 6.8, 1.6$ Hz, 2H, *Z* + 2H, *E*), 7.28-7.22 (m, 1H, *Z* + 1H, *E*), 7.20-7.15 (m, 1H, *Z* + 1H, *E*), 6.94 (d, $J = 12.8$ Hz, 1H, *E*), 6.30 (d, $J = 12.8$ Hz, 1H, *E*), 6.27 (d, $J = 7.2$ Hz, 1H, *Z*), 5.92 (s, 1H, *Z*), 5.90 (s, 1H, *E*), 5.71 (d, $J = 7.2$ Hz, 1H, *Z*), 3.76 (s, 3H, *Z*), 3.73 (s, 3H, *E*), 2.47 (bs, 1H, *Z*), 2.32 (bs, 1H, *E*).

¹³C NMR (100 MHz, CDCl₃) δ 150.8 (CH, *E*), 148.9 (CH, *Z*), 136.8 (CH, *E*), 136.7 (C, *E*), 135.2 (C, *Z*), 133.8 (CH, *Z*), 133.79 (CH, *E*), 133.7 (CH, *Z*), 132.63 (CH, *E*), 132.6 (CH, *Z*), 130.1 (CH, *E*), 129.9 (C, *Z*), 129.8 (CH, *Z*), 129.0 (C, *E*), 128.6 (CH, *Z*), 127.55 (CH, *E*), 127.5 (CH, *Z*), 127.2 (CH, *E*), 127.1 (CH, *Z*), 126.7 (CH, *Z*), 126.6 (CH, *E*), 126.59 (CH, *E*), 125.85 (C, *Z*), 125.8 (C, *E*), 125.0 (C, *Z*), 124.9 (C, *E*), 102.0 (CH, *Z*), 101.9 (CH, *E*), 93.5 (C, *Z*), 93.3 (C, *E*), 85.6 (C, *E*), 85.4 (C, *Z*), 63.6 (CH, *Z*), 63.5 (CH, *E*), 60.8 (CH₃, *Z*), 56.8 (CH₃, *E*). HRMS-ESI calcd for C₁₈H₁₅BrO₂ (*M*+Na)⁺: 365.0152; found: 365.0153.

(*Z*)-3-(3-Chlorophenyl)-1-(2-(2-methoxyvinyl)phenyl)prop-2-yn-1-ol (45h).

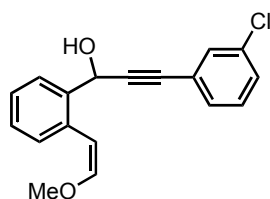

This compound was prepared according to the general procedure **B** starting from 1-bromo-2-(2-methoxyvinyl)benzene **91** and 3-(3-chlorophenyl)propionaldehyde **65**. Yellow oil (67%).

¹H NMR (400 MHz, CDCl₃) δ 7.96 (dd, $J = 7.2$ Hz, 1H), 7.55 (dd, $J = 7.2$ Hz, 1H), 7.47-7.43 (m, 2H), 7.41-7.32 (m, 2H), 7.28-7.12 (m, 1H), 6.97-6.87 (m, 1H), 6.15 (d, $J = 5.6$ Hz, 1H), 6.10 (d, $J = 7.2$ Hz, 1H), 5.44 (d, $J = 7.2$ Hz, 1H), 3.89 (s, 3H), 2.59 (d, $J = 5.6$ Hz, 1H).

^{13}C NMR (100 MHz, CDCl_3) δ 153.6 (CH), 143.6 (C), 137.8 (C), 136.2 (C), 133.7 (C), 131.0 (CH), 129.8 (CH), 129.4 (CH), 128.8 (CH), 127.4 (CH), 126.6 (CH), 120.2 (CH), 117.8 (CH), 105.1 (CH), 93.04 (C), 83.5 (C), 62.5 (CH), 60.7 (CH_3). HRMS-ESI calcd for $\text{C}_{18}\text{H}_{15}\text{ClO}_2$ ($M+\text{Na}$) $^+$: 321.0658; found: 321.0650.

1-(2-(2-Methoxyvinyl)phenyl)-3-(naphthalen-1-yl)prop-2-yn-1-ol (45i).

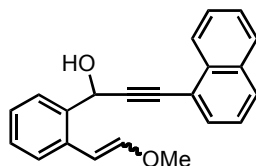

This compound was prepared according to the general procedure **B** starting from 1-bromo-2-(2-methoxyvinyl)benzene **91** and 3-(naphthalen-1-yl)propionaldehyde **94**. Amber oil (70%, 1:1 *E/Z*).

^1H NMR (400 MHz, CDCl_3) δ 8.31 (dd, $J = 8.2, 2.0$ Hz, 2H, *E+Z*), 7.87-7.79 (m, 6H, *E+Z*), 7.69 (dt, $J = 7.2, 2.0$ Hz, 2H, *E+Z*), 7.52 (tquint, $J = 6.4, 1.6$ Hz, 4H), 7.43-7.24 (m, 7H), 6.97 (d, $J = 12.8$ Hz, 1H, *E*), 6.37 (d, $J = 12.8$ Hz, 1H, *E*), 6.27 (d, $J = 7.2$ Hz, 1H, *Z*), 6.03 (s, 1H, *E*), 6.00 (s, 1H, *Z*), 5.75 (d, $J = 7.2$ Hz, 1H, *Z*), 3.75 (s, 3H, *E*), 3.72 (s, 3H, *Z*), 2.51 (bs, 2H).

^{13}C NMR (100 MHz, CDCl_3) δ 150.7 (CH), 148.8 (CH), 137.3 (C), 137.0 (C), 135.1 (C), 133.6 (C), 133.5 (C), 133.4 (C), 133.3 (CH), 130.8(CH_2), 130.2 (CH), 129.1 (CH), 129.0 (CH), 128.9 (CH), 128.5 (CH), 128.4 (CH), 128.39 (CH), 127.4 (CH), 127.3 (CH), 127.0 (CH), 126.9 (CH), 126.7 (CH), 126.6(CH_2), 126.5 (CH), 126.4 (CH), 126.3 (CH), 125.3(CH_2), 120.5 (C), 120.4 (C), 102.1(CH_2), 93.9 (C), 93.7 (C), 85.1 (C), 84.9 (C), 63.7 (CH_2), 60.8 (CH_3), 56.7 (CH_3). HRMS-ESI calcd for $\text{C}_{22}\text{H}_{18}\text{O}_2$ ($M+\text{Na}$) $^+$: 337.1193; found: 337.1204.

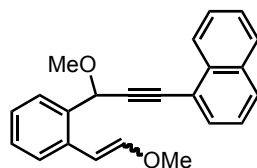
1-(3-Methoxy-3-(2-(2-methoxyvinyl)phenyl)prop-1-ynyl)naphthalene (45'i).

This compound was prepared by methylation of 1-(2-(2-methoxyvinyl)phenyl)-3-(naphthalen-1-yl)prop-2-yn-1-ol (**45i**), according to the general procedure C. Yellow oil (56%, 1:1 *E/Z*).

^1H NMR (400 MHz, CDCl_3) δ 8.33 (d, $J = 7.6$ Hz, 2H, *E+Z*), 7.97 (d, $J = 8.0$ Hz, 1H, *Z*), 7.84 (dt, $J = 7.6, 2.8$ Hz, 4H, *E+Z*), 7.76 (dd, $J = 3.4, 1.6$ Hz, 2H, *E+Z*), 7.71 (d, $J = 7.6$ Hz, 2H, *E+Z*), 7.53 (tquint, $J = 6.4, 1.6$ Hz, 4H, *E+Z*), 7.45-7.21 (m, 7H, *E+Z*), 6.97 (d, $J = 12.8$ Hz, 1H, *E*), 6.31 (d, $J = 12.8$ Hz, 1H, *E*), 6.27 (d, $J = 6.8$ Hz, 1H, *Z*), 5.71 (d, $J = 6.8$ Hz, 1H, *Z*), 5.64 (s, 1H, *E*), 5.60 (s, 1H, *Z*), 3.77 (s, 3H, *E*), 3.73 (s, 3H, *Z*), 3.59 (s, 3H, *E*), 3.56 (s, 3H, *Z*).

^{13}C NMR (100 MHz, CDCl_3) δ 150.5 (CH_2), 148.7 (CH_2), 135.6 (C), 134.9 (C), 134.8 (C), 134.3 (C), 133.6 (C), 133.5 (C), 133.3 (CH), 130.9 (CH), 130.89 (CH), 130.1 (CH), 129.1 (CH), 129.0 (CH), 128.9 (CH), 128.5 (C), 128.47 (CH_2), 128.4 (C), 128.1 (CH), 127.0 (CH), 126.9 (CH), 126.6 (CH), 126.57 (CH), 126.4 (CH), 126.37 (CH), 126.33 (CH_2), 126.3 (CH), 125.3 (CH), 120.6 (C), 120.5 (C), 102.4 (CH), 101.9 (CH), 91.9 (C), 91.7 (C), 86.3 (C), 86.0 (C), 72.2 (CH), 72.0 (CH), 60.8 (CH_3), 56.7 (CH_3), 56.3 (CH_3), 56.2 (CH_3). HRMS-ESI calcd for $\text{C}_{23}\text{H}_{20}\text{O}_2$ ($M+\text{Na}$) $^+$: 351.1353; found: 351.1361.

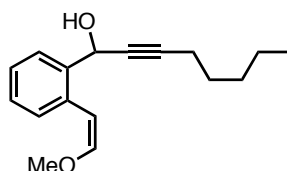
(Z)-1-(2-(2-Methoxyvinyl)phenyl)oct-2-yn-1-ol (45j).

This compound was prepared according to the general procedure B starting from 1-bromo-2-(2-methoxyvinyl)benzene **91** and oct-2-ynal. Colorless oil (61%).

^1H NMR (400 MHz, CDCl_3) δ 7.80 (dd, $J = 7.6, 1.2$ Hz, 1H), 7.69 (dd, $J = 7.4, 1.2$ Hz, 1H), 7.28 (dt, $J = 7.6, 1.2$ Hz, 1H), 7.2 (dt, $J = 7.6, 1.2$ Hz, 1H), 6.23 (d, $J = 7.2$ Hz, 1H), 5.64 (bs, 1H), 5.62 (d, $J = 7.2$ Hz, 1H), 3.74 (s, 3H), 2.26 (dt, $J = 7.2, 2$ Hz, 1H), 2.24 (bs, 1H), 1.54 (quint, $J = 7.2$ Hz, 2H), 1.40-1.30 (m, 4H), 0.89 (t, $J = 7.2$ Hz, 3H).

^{13}C NMR (100 MHz, CDCl_3) δ 148.6 (CH), 137.7 (C), 133.4 (C), 130.0 (CH), 128.2 (CH), 127.0 (CH), 126.5 (CH), 102.03 (CH), 87.8 (C), 79.9 (C), 63.09 (CH), 60.7 (OCH₃), 31.3 (CH₂), 28.5 (CH₂), 22.4 (CH₂), 19.0 (CH₂), 141.1 (CH₃). MALDI calcd for $\text{C}_{17}\text{H}_{22}\text{O}_2$ (M)⁺ 258.1619; found; 258.1613.

Naphthalenes 47a-j. Scheme 2.24.

2-Phenyl-naphthalene (47a).

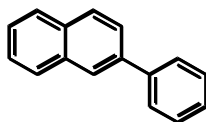

This compound was prepared by cyclization of enynes **45a** and **45'a** according to the general procedure **F**. White solid. 96%, from the alcohol; 94%, from the methyl ether. The spectroscopic data for this compound matched with those reported in the literature.²³

2-(4-Methoxyphenyl)naphthalene (47b).

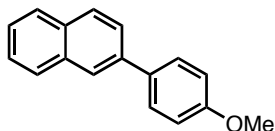

This compound was prepared by cyclization of enynes **45b** and **45'b** according to the general procedure **F**. Beige solid. 90%, from alcohol; 67%, from methyl ether. The spectroscopic data for this compound matched with those reported in the literature.²⁴

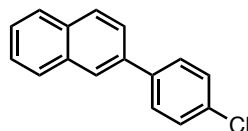
2-(4-Chlorophenyl)naphthalene (47c).

This compound was prepared by cyclization of enyne **45c** and **45'c** according to the general procedure **F**. White solid. 94%, from the alcohol; 80%, from the methyl ether. The spectroscopic data for this compound matched with those reported in the literature.²⁵

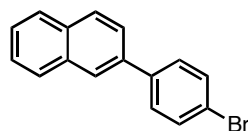
2-(4-Bromophenyl)naphthalene (47d).

This compound was prepared by cyclization of enyne **45d** according to the general procedure **F**. Brown solid. 91%, from the alcohol. The spectroscopic data for this compound matched with those reported in the literature.²⁶

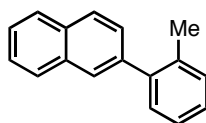
2-(*o*-Tolyl)naphthalene (47e).

This compound was prepared by cyclization of enyne **45e** according to the general procedure **F**. Yellow oil. 83% from the alcohol. The spectroscopic data for this compound matched with those reported in the literature.²⁷

2-(2-Ethylphenyl)naphthalene (47f).

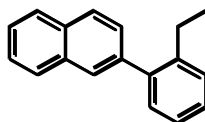

This compound was prepared by cyclization of enynes **45f** and **45'f** according to the general procedure **F**. Colorless oil (88%, from the alcohol; 78% from the methyl ether). ^1H NMR (400 MHz, CDCl_3) δ 7.87 (q, $J = 8.4$ Hz, 3H), 7.77 (bs, 1H), 7.63 (dq, $J = 8.0, 2.0$ Hz, 2H), 7.52 (d, $J = 6.8$ Hz, 2H), 7.47 (tt, $J = 8.4, 2.0$ Hz, 1H), 7.35 (t, $J = 2.4$ Hz, 2H), 7.30-7.25 (m, 2H), 1.11 (dt, $J = 8.0, 2.0$ Hz, 3H).

^{13}C NMR (100 MHz, CDCl_3) δ 142.0 (C), 141.7 (C), 139.8 (C), 133.5 (C), 132.5 (C), 130.4 (CH), 128.8 (CH), 128.2 (CH), 128.0 (CH), 127.9 (CH), 127.89 (CH), 127.8 (CH), 127.6 (CH), 126.4 (CH), 126.0 (CH), 125.8 (CH), 26.4 (CH_2), 15.9 (CH_3). HRMS-APCI calcd for $\text{C}_{18}\text{H}_{17}$ ($M+\text{H}$) $^+$: 233.1329; found: 233.1330.

2-(2-Bromophenyl)naphthalene (47g).

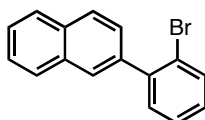

This compound was prepared by cyclization of enyne **45g** according to the general procedure **F**. Red oil. 87%, from the alcohol. The spectroscopic data for this compound matched with those reported in the literature.²⁸

2-(3-Chlorophenyl)naphthalene (47h).

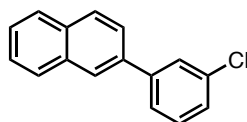

This compound was prepared by cyclization of enyne **45h** according to the

general procedure **F**. White solid. 87%, from the alcohol. The spectroscopic data for this compound matched with those reported in the literature.²⁹

1,2'-Binaphthalene (47i).

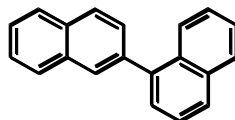

This compound was prepared by cyclization of enynes **45i** and **45'i** according to the general procedure **F**. Colorless oil. 85%, from the alcohol; 72%, from the the methyl ether. The spectroscopic data for this compound matched with those reported in the literature.³⁰

2-Pentyl-naphthalene (47j).

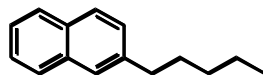

This compound was prepared by cyclization of enyne **45h** according to the general procedure **F**. Yellow oil. 87% from the alcohol. The spectroscopic data for this compound matched with those reported in the literature.³¹

1-Bromo-4-methoxy-2-(2-methoxyvinyl)benzene (91').

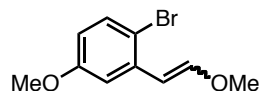

This compound was prepared according to the general procedure **A** starting from 2-bromo-5-methoxybenzaldehyde and (methoxymethyl)triphenylphosphonium chloride. Colorless oil (98%, 1.4:1 *E/Z*).

¹H NMR (400 MHz, CDCl₃) δ 7.67 (d, *J* = 3.2 Hz, 1H), 7.40 (d, *J* = 8.8 Hz, 1H, *E* + 1H, *Z*), 6.97 (d, *J* = 12.8 Hz, 1H, *E*), 6.87 (d, *J* = 3.2 Hz, 1H, *Z*), 6.62-6.57 (m, 1H, *E* + 1H, *Z*), 6.25 (d, *J* = 7.2 Hz, 1H, *Z*), 6.05 (d, *J* = 12.8 Hz, 1H, *E*),

5.56 (d, $J = 7.2$ Hz, 1H, Z), 3.79 (s, 3H, E), 3.78 (s, 3H, Z), 3.77 (s, 3H, Z), 3.73 (s, 3H, E).

^{13}C NMR (100 MHz, CDCl_3) δ 159.1 (C, E), 158.8 (C, Z), 150.8 (CH, E), 149.6 (CH, Z), 137.2 (C, E), 135.9 (C, Z), 133.5 (CH, E), 133.0 (CH, Z), 115.8 (CH, Z), 113.9 (C, E), 113.7 (C, Z), 113.4 (CH, Z), 113.3 (CH, E), 111.2 (CH, E), 104.7 (CH, E), 104.1 (CH, E), 61.1 (OCH_3 , Z), 56.7 (OCH_3 , E), 55.6 (OCH_3 , E), 55.56 (OCH_3 , E). MALDI calcd for $\text{C}_{10}\text{H}_{11}\text{BrO}$ (M) $^+$ 241.9941; found; 241.9953.

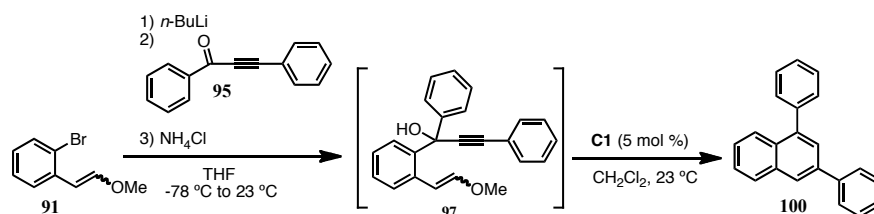

1,3-Diphenyl-naphthalene (100). This known compound³² was synthesized in 87% overall yield by direct cyclization of crude adduct **97**. This unstable adduct was prepared from 1-bromo-2-(2-methoxyvinyl)benzene **91** and 1,3-diphenylprop-2-yn-1-one **95** according to the general procedure **B**.

Adduct **97** (1:1 *E/Z*). ^1H NMR (400 MHz, CDCl_3) δ 7.88 (dd, $J = 7.4, 1.2$ Hz, 2H, *E+Z*), 7.57 (t, $J = 7.2$ Hz, 4H, *E+Z*), 7.48-7.42 (m, 4H, *E+Z*), 7.36-7.20 (m, 18H, *E+Z*), 6.67 (d, $J = 12.8$ Hz, 1H, *E*), 6.04 (d, $J = 12.8$ Hz, 1H, *E*), 5.91 (d, $J = 7.2$ Hz, 1H, Z), 5.49 (d, $J = 7.2$ Hz, 1H, Z), 3.58 (s, 3H, *E*), 3.39 (s, 3H, Z).

^{13}C NMR (100 MHz, CDCl_3) δ 148.6, 147.3, 144.6, 144.4 (C, *E*), 143.4 (C, Z), 140.1 (C, *E*), 140.0 (C, Z), 134.6 (C, *E*), 133.4 (C, Z), 131.7 (CH), 131.6 (CH), 131.2 (CH), 130.9 (CH), 128.8 (CH), 128.6 (CH), 128.5 (CH), 128.3 (CH), 128.2 (CH), 127.9 (CH), 127.7 (CH), 126.9 (CH), 126.7 (CH), 126.5 (CH), 126.4 (CH), 125.8 (CH), 125.7 (CH), 122.8 (C, *E*), 122.6 (C, Z), 120.1 (CH), 117.7 (CH), 104.5 (CH), 104.0 (CH), 91.6 (C, *E*), 91.2 (C, Z), 87.9 (C, *E*), 87.7 (C, Z), 74.7 (C, *E*), 74.5 (C, Z), 60.4 (OCH_3), 55.8 (OCH_3).

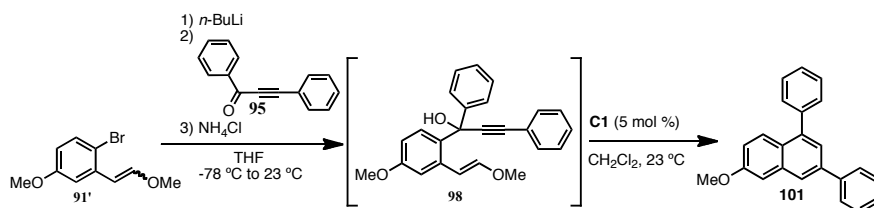

6-Methoxy-1,3-diphenylnaphthalene (101). This compound was synthesized in 81% overall yield by direct cyclization of crude adduct **98**. This unstable adduct was prepared from 1-bromo-4-methoxy-2-(2-methoxyvinyl)benzene **91'** and 1,3-diphenylprop-2-yn-1-one **95** according to the general procedure **B**.

Adduct **98** (*E*). ^1H NMR (400 MHz, CDCl_3) δ 7.81 (d, $J = 8.8$ Hz, 1H), 7.58 (d, $J = 8.0$ Hz, 2H), 7.48-7.44 (m, 2H), 7.36-7.28 (m, 7H), 6.84 (d, $J = 2.8$ Hz, 1H), 6.78 (dd, $J = 9.2, 1.4$ Hz, 1H), 6.70 (d, $J = 12.8$ Hz, 1H), 6.05 (d, $J = 12.8$ Hz, 1H), 3.82 (s, 3H), 3.41 (s, 3H).

^{13}C NMR (100 MHz, CDCl_3) δ 159.6 (C), 149.0 (CH), 144.9 (C), 136.3 (C), 133.0 (C), 131.8 (CH), 128.7 (CH), 128.7 (CH), 128.5 (CH), 128.48 (CH), 128.4 (C), 128.2 (CH), 128.0 (CH), 126.8 (CH), 122.8 (C), 112.9 (CH), 110.4 (CH), 104.7 (CH), 91.7 (C), 87.9 (C), 74.5 (C), 56.0 (OCH_3), 55.5 (OCH_3).

6-Methoxy-1,3-diphenylnaphthalene (**101**). Colorless oil. ^1H NMR (400 MHz, CDCl_3) δ 7.97 (d, $J = 1.2$ Hz, 1H), 7.82 (d, $J = 7.2$ Hz, 1H), 7.76 (d, $J = 7.2$ Hz, 2H), 7.59-7.44 (m, 8H), 7.38 (tt, $J = 7.2$ Hz, 1.2 Hz, 1H), 7.27 (d, $J = 1.4$ Hz, 1H), 7.10 (dd, $J = 10.0, 1.4$ Hz, 1H), 3.96 (s, 3H).

^{13}C NMR (100 MHz, CDCl_3) δ 158.1 (C), 141.3 (C), 141.04 (C), 141.02 (C), 138.9 (C), 135.7 (C), 130.2 (CH), 129.0 (CH), 128.5 (CH), 127.8 (CH), 127.65 (CH), 127.61 (CH), 127.55 (CH), 126.5 (C), 124.8 (CH), 124.5 (CH), 118.9 (CH), 106.6 (CH), 55.6 (OCH_3). MALDI calcd for $\text{C}_{23}\text{H}_{18}\text{O}$ (M) $^+$ 310.1354; found; 310.1343.

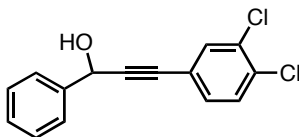
3-(3,4-Dichlorophenyl)-1-phenylprop-2-yn-1-ol (S5).

This compound was prepared according to the general procedure **B** in 89% yield starting from benzaldehyde and 1,2-dichloro-4-ethynylbenzene. Bright yellow oil.

^1H NMR (400 MHz, CDCl_3) δ 7.61-7.57 (m, 2H), 7.55 (d, $J = 1.6$ Hz, 1H), 7.45-7.33 (m, 4H), 7.28 (dd, $J = 8.0, 1.6$ Hz, 1H), 5.68 (bs, 1H), 2.27 (bs, 1H).

^{13}C NMR (100 MHz, CDCl_3) δ 140.5 (C), 133.5 (CH), 133.3 (C), 132.7 (CH), 131.0 (CH), 130.5 (CH), 128.9 (CH), 126.8 (CH), 122.5 (C), 118.0 (C), 91.0 (C), 84.4 (C), 65.1 (CH). HRMS-APCI calcd for $\text{C}_{15}\text{H}_{11}\text{Cl}_2\text{O}$ ($M+\text{H}$) $^+$: 277.0184; found: 277.0178.

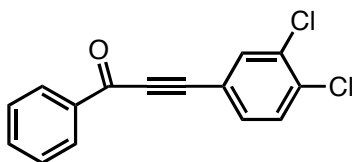
3-(3,4-Dichlorophenyl)-1-phenylprop-2-yn-1-one (96).

This compound was synthesized in 77% yield by oxidation of propargylic alcohol **S5**, according to the general procedure **E**. Colorless oil.

^1H NMR (400 MHz, CDCl_3) δ 8.19 (d, $J = 7.2$ Hz, 2H), 7.77 (t, $J = 1.2$ Hz, 1H), 7.66 (tt, $J = 7.2, 1.2$ Hz, 1H), 7.54 (d, $J = 8.0$ Hz, 2H), 7.51 (d, $J = 0.8$ Hz, 2H).

^{13}C NMR (100 MHz, CDCl_3) δ 177.8 (C), 136.8 (C), 135.8 (C), 134.6 (CH), 134.6 (C), 133.4 (CH), 132.2 (CH), 131.1 (CH), 129.8 (CH), 128.9 (CH), 120.3 (C), 89.9 (C), 88.2 (C). HRMS-ESI calcd for $\text{C}_{15}\text{H}_8\text{Cl}_2\text{O}$ ($M+\text{Na}$) $^+$: 296.9847; found: 296.9841.

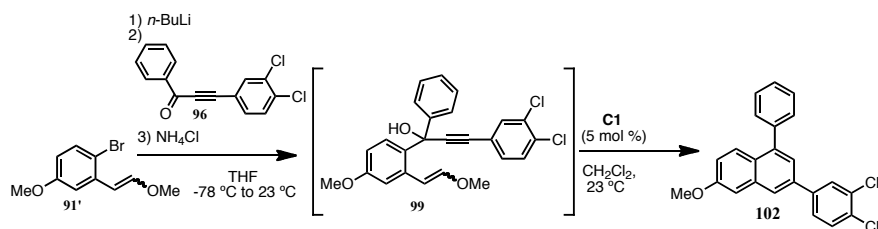

3-(3,4-Dichlorophenyl)-6-methoxy-1-phenylnaphthalene (102). This compound was synthesized in 72% overall yield by direct cyclization of crude adduct **99**. This unstable adduct was prepared from 1-bromo-4-methoxy-2-(2-methoxyvinyl)benzene (**91'**) and 3-(3,4-dichlorophenyl)-1-phenylprop-2-yn-1-one (**96**) according to the general procedure **B**.

Adduct **99** (1:1 *E/Z*). ^1H NMR (400 MHz, CDCl_3) δ 7.75 (d, $J = 8.8$ Hz, 1H, *E*), 7.71 (d, $J = 8.8$ Hz, 1H, *Z*), 7.57-7.50 (m, 4H, *E* + 4H, *Z*), 7.39-7.28 (m, 5H, *E*, + 5H, *Z*), 6.83 (d, $J = 2.4$ Hz, 1H, *E*), 6.77 (d, $J = 2.4$ Hz, 1H, *Z*), 6.68 (d, $J = 12.8$ Hz, 1H, *E*), 5.97 (d, $J = 12.8$ Hz, 1H, *Z*), 5.95 (d, $J = 7.2$ Hz, 1H, *E*), 5.41 (d, $J = 7.2$ Hz, 1H, *E*), 3.82 (s, 3H, *E+Z*), 3.64 (s, 3H, *E*), 3.41 (s, 3H, *Z*), 3.04 (bs, 1H, *E*), 2.95 (bs, 1H, *Z*).

^{13}C NMR (100 MHz, CDCl_3) δ 159.6 (CH), 159.2 (CH), 148.9 (CH), 147.8 (CH), 144.6 (CH), 144.4 (CH), 136.2 (CH), 134.8 (CH), 133.4 (CH), 133.3 (CH), 133.03 (C), 132.9 (C), 132.6 (C), 132.56 (C), 132.5 (C), 132.36 (C), 130.9 (CH), 130.8 (CH), 130.5 (CH), 130.4 (CH), 128.48 (CH), 128.4 (CH), 128.2 (C), 128.1 (C), 128.0 (C), 127.9 (C), 126.7 (CH), 126.6 (CH), 122.9 (C), 122.7 (C), 116.9 (CH), 112.9 (CH), 110.6 (CH), 110.4 (CH), 104.7 (CH), 103.8 (CH), 94.2 (C), 93.9 (C), 85.5 (C), 85.1 (C), 74.5 (C), 74.4 (C), 60.7 (OCH_3), 56.1 (OCH_3), 55.4 (OCH_3), 55.3 (OCH_3).

3-(3,4-Dichlorophenyl)-6-methoxy-1-phenylnaphthalene (**102**). ^1H NMR (400 MHz, CDCl_3) δ 7.90 (d, $J = 1.6$ Hz, 1H), 7.81 (d, $J = 2.0$ Hz, 1H), 7.57-7.43 (m, 8H), 7.25 (d, $J = 2.0$ Hz, 1H), 7.11 (dd, $J = 9.2, 2.8$ Hz, 1H), 3.95 (s, 3H).

^{13}C NMR (100 MHz, CDCl_3) δ 158.3 (C), 141.5 (C), 141.3 (C), 140.7 (C), 136.3 (C), 135.6 (C), 133.1 (C), 131.7 (C), 130.9 (CH), 130.1 (CH), 129.4 (CH), 128.6 (CH), 127.8 (CH), 127.7 (CH), 126.9 (C), 126.8 (CH), 124.6 (CH), 123.9 (CH), 119.5 (CH), 106.7 (CH), 55.6 (OCH_3). MALDI calcd for $\text{C}_{23}\text{H}_{16}\text{Cl}_2\text{O}$ (M^+)⁺ 378.0573; found; 378.0567.

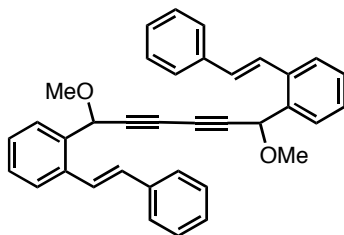
1,6-Dimethoxy-1,6-bis(2-((*E*)-styryl)phenyl)hexa-2,4-diyne (106).

This compound was synthesized starting from **117** following the general procedure **D** without any iodide. Yellow oil (92%).

^1H NMR (400 MHz, CDCl_3) δ 7.59 (dd, $J = 13.4, 7.6$ Hz, 2H), 7.53 – 7.47 (m, 3H), 7.37 – 7.32 (m, 3H), 7.30 – 7.25 (m, 2H), 6.99 (d, $J = 16.1$ Hz, 1H), 5.39 (s, 1H), 3.45 (s, 3H).

^{13}C NMR (101 MHz, CDCl_3) δ 137.5, 136.7, 134.6, 132.0, 129.3, 128.9, 128.4, 128.1, 127.9, 126.9, 126.7, 125.5, 77.7, 72.3, 71.7, 56.5. HRMS-ESI calcd for $\text{C}_{36}\text{H}_{36}\text{O}_2$ ($M+\text{Na}$) $^+$: 517.2159; found: 517.2144.

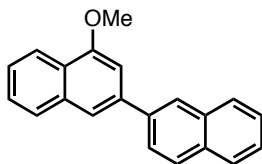
4-Methoxy-2,2'-binaphthalene (107).

This compound was prepared by cyclization of enyne **106** using 20 mol% of catalyst, according to the general procedure **F** in 29% yield as colorless oil.

^1H NMR (400 MHz, CDCl_3) δ 8.28 (d, $J = 7.9$ Hz, 1H), 8.16 (s, 1H), 7.95 (t, $J = 7.3$ Hz, 2H), 7.89 (dd, $J = 7.0, 5.0$ Hz, 3H), 7.76 (s, 1H), 7.51 (td, $J = 13.5, 6.5$ Hz, 4H), 7.19 (s, 1H), 4.12 (s, 3H).

^{13}C NMR (101 MHz, CDCl_3) δ 156.1, 139.2, 139.0, 134.9, 133.9, 132.9, 128.7, 128.4, 128.0, 127.9, 127.1, 126.6, 126.2, 126.2, 126.0, 125.6, 125.1, 122.2, 119.0, 104.1, 55.9. HRMS-APCI calcd for $\text{C}_{21}\text{H}_{16}\text{O}$ ($M+\text{H}$) $^+$: 285.1274; found: 285.1279.

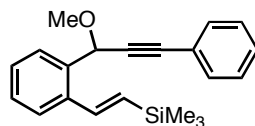
(E)-2-(2-(1-Methoxy-3-phenylprop-2-yn-1-yl)styryl)trimethylsilane (110).

This compound was prepared in 61% yield according to the general procedure **B** starting from **109** and 3-phenylpropionaldehyde **60**. Amber oil.

^1H NMR (400 MHz, CDCl_3) δ 7.67 (dd, $J = 7.3, 1.6$ Hz, 1H), 7.61-7.55 (m, 1H), 7.46 (dd, $J = 6.7, 3.0$ Hz, 2H), 7.38 (d, $J = 19.0$ Hz, 1H), 7.34-7.27 (m, 5H), 6.43 (d, $J = 19.0$ Hz, 1H), 5.49 (s, 1H), 3.53 (s, 3H), 0.17 (s, 9H).

^{13}C NMR (101 MHz, CDCl_3) δ 140.9, 138.1, 135.2, 133.2, 131.9, 128.9, 128.7, 128.5, 128.1, 127.9, 126.4, 122.8, 88.4, 86.8, 71.7, 56.5, -1.0. HRMS-ESI calcd for $\text{C}_{21}\text{H}_{24}\text{OSi}$ ($M+\text{Na}$) $^+$: 343.1511; found: 343.1518.

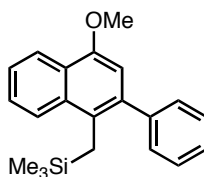
((4-Methoxy-2-phenylnaphthalen-1-yl)methyl)trimethylsilane (111).

This compound was prepared by cyclization of enyne **110**, according to the general procedure **F** in 68% yield as amber oil.

^1H NMR (400 MHz, CDCl_3) δ 8.36-8.31 (m, 1H), 7.97 (d, $J = 8.2$ Hz, 1H), 7.59-7.36 (m, 7H), 6.72 (s, 1H), 3.99 (s, 3H), 2.60 (s, 2H), -0.21 (s, 9H).

^{13}C NMR (126 MHz, CDCl_3) δ 152.16, 144.10, 137.25, 133.11, 130.17, 128.33, 126.85, 126.65, 126.21, 125.54, 125.43, 124.87, 122.43, 107.28, 55.68, 18.88, -0.13. MALDI calcd for $\text{C}_{21}\text{H}_{24}\text{OSi}$ (M) $^+$: 320.1596; found: 320.1576.

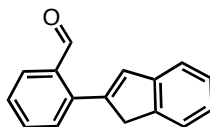
2-(1*H*-Inden-2-yl)benzaldehyde (112).

A screw-cap test-tube, equipped with a magnetic stir bar, was charged with 2-bromoindene (194.0 mg, 1.0 mmol), 2-formylboronic acid (225.1 mg 1.5 mmol), K_3PO_4 (423.4 mg, 2.0 mmol) and $Pd(PPh_3)_4$ (115.4 mg, 0.1 mmol, 10 mol%). The vial was sealed with a teflon screw-cap, then evacuated and backfilled with argon. Deoxygenated dioxane (2.9 mL, 0.035 M) were added and stirred at 70 °C in a preheated oil bath for 40 min. The reaction is diluted with 8 mL of EtOAc. The organic phase was extracted dried over magnesium sulfate and concentrated to dryness. The crude product such gotten was adsorbed in basic alumine and purified by flash chromatography using basic alumine as stationary phase to yield 22.4 mg, 15% of the desired compound as yellow oil.

1H NMR (400 MHz, $CDCl_3$) δ 10.26 (s, 1H), 7.98 (dd, $J = 7.8, 1.0$ Hz, 1H), 7.62 (td, $J = 7.7, 1.4$ Hz, 1H), 7.52 (t, $J = 6.6$ Hz, 2H), 7.45 (t, $J = 8.1$ Hz, 2H), 7.34 (t, $J = 7.3$ Hz, 1H), 7.29 – 7.25 (m, 1H), 6.85 (s, 1H), 3.87 (s, 2H).

^{13}C NMR (101 MHz, $CDCl_3$) δ 192.4, 144.8, 143.7, 143.0, 141.0, 135.5, 134.9, 133.6, 129.6, 128.5, 127.8, 127.1, 125.8, 124.0, 121.7, 42.2. HRMS-ESI calcd for $C_{16}H_{20}O$ ($M+Na$) $^+$: 243.0793; found: 243.0786.

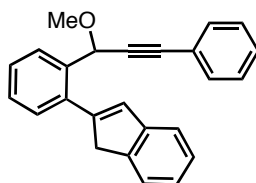
2-(2-(1-Methoxy-3-phenylprop-2-yn-1-yl)phenyl)-1*H*-indene (113).

This compound was prepared according to the general procedure **B** starting from phenylacetylene and 2-(1*H*-inden-2-yl)benzaldehyde (**112**) in presence of 2 equiv

of GaCl₃·2LiCl. After aqueous work up, general procedure C was followed to give a yellow oil (56%), corresponding to desired enyne.

¹H NMR (400 MHz, CDCl₃) δ 7.94 – 7.88 (m, 1H), 7.53 – 7.41 (m, 4H), 7.40 – 7.35 (m, 3H), 7.34 – 7.26 (m, 4H), 7.25 – 7.19 (m, 1H), 7.05 (s, 1H), 5.51 (s, 1H), 3.80 (s, 2H), 3.48 (s, 3H).

¹³C NMR (101 MHz, CDCl₃) δ 145.5, 145.4, 143.6, 137.1, 136.7, 131.9, 131.8, 129.2, 128.7, 128.7, 128.5, 128.5, 127.8, 126.8, 125.1, 123.8, 122.8, 121.4, 87.9, 87.6, 70.9, 56.0, 43.1. HRMS-ESI calcd for C₂₅H₂₀O (*M*+Na)⁺: 359.1418; found: 359.1412.

(6aR^{*},6bS^{*},11aR^{*})-5-Methoxy-6a-phenyl-6b,11-dihydro-6aH-indeno[2',1':1,3]cyclopropa[1,2-*a*]naphthalene (114).

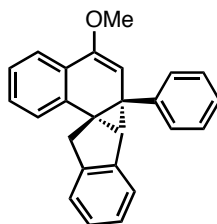

This compound was prepared by cyclization of enyne **113**, according to the general procedure F in 51% yield as brown solid. m.p 172-173.

¹H NMR (500 MHz, CDCl₃) δ 7.81 (dd, *J* = 7.8, 1.4 Hz, 1H), 7.60 (d, *J* = 7.6 Hz, 1H), 7.42 (d, *J* = 7.5 Hz, 1H), 7.36 (td, *J* = 7.6, 1.5 Hz, 1H), 7.30 – 7.26 (m, 1H), 7.14 (td, *J* = 7.5, 0.9 Hz, 1H), 7.05 (d, *J* = 6.0 Hz, 3H), 6.96 (td, *J* = 7.4, 1.1 Hz, 3H), 6.84 (d, *J* = 7.5 Hz, 1H), 5.32 (s, 1H), 4.02 (d, *J* = 17.7 Hz, 1H), 3.69 (s, 3H), 2.82 (d, *J* = 17.7 Hz, 1H), 2.12 (d, *J* = 1.1 Hz, 1H).

¹³C NMR (101 MHz, CDCl₃) δ 149.3, 143.0, 141.7, 140.2, 136.4, 131.1, 128.4, 128.3, 127.8, 126.6, 126.3, 125.9, 125.7, 125.7, 125.3, 124.4, 122.6, 104.4, 55.0, 42.0, 39.3, 37.8, 35.9. HRMS-ESI calcd for C₂₅H₂₀O (*M*+H)⁺: 337.1605; found: 337.1592.

1-Phenyl-7,12-dihydropleiadene (115).

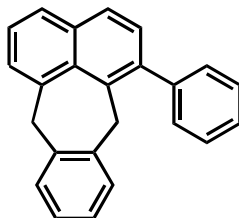

This compound was prepared by cyclization of enyne **113**, according to the general procedure **F** in 22% yield as yellow oil.

^1H NMR (500 MHz, CDCl_3) δ 7.65 (dd, $J = 7.3, 1.7$ Hz, 1H), 7.56 (d, $J = 7.4$ Hz, 1H), 7.42-7.35 (m, 2H), 7.34-7.31 (m, 1H), 7.31-7.26 (m, 5H), 7.18 (td, $J = 7.4, 1.1$ Hz, 1H), 7.05 (t, $J = 7.6$ Hz, 1H), 6.60 (d, $J = 7.7$ Hz, 1H), 6.10 (t, $J = 7.3$ Hz, 1H), 4.43 (bs, 1H), 3.86 (bs, 1H), 3.47 (bs, 1H), 2.96 (bs, 1H).

^{13}C NMR (126 MHz, CDCl_3) δ 146.5, 145.1, 142.4, 140.6, 138.9, 138.7, 136.8, 135.6, 128.9, 128.5, 128.3, 127.8, 127.5, 127.4, 126.4, 126.2, 126.1, 124.9, 123.9, 123.3, 40.8, 34.8. MALDI calcd for $\text{C}_{24}\text{H}_{18}$ (M^+): 306.1403; found: 306.1403.

1-(2-(2-Methoxyvinyl)phenyl)-3-phenylprop-2-yn-1-yl acetate (116).

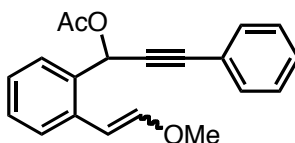

This compound was synthesized by acetylation of **45a** in 83% yield. Amber oil.

^1H NMR (400 MHz, CDCl_3) δ 7.70 (dd, $J = 7.5, 1.3$ Hz, 1H), 7.46 (dd, $J = 7.4, 2.1$ Hz, 2H), 7.34-7.24 (m, 6H), 6.92 (d, $J = 12.7$ Hz, 1H), 6.86 (s, 1H), 6.15 (d, $J = 12.7$ Hz, 1H), 3.71 (s, 3H), 2.13 (s, 3H).

^{13}C NMR (101 MHz, CDCl_3) δ 169.8, 150.5, 135.3, 133.5, 131.9, 129.2, 128.8, 128.6, 128.3, 126.3, 126.2, 122.2, 101.6, 87.2, 85.6, 64.2, 56.4, 21.0. HRMS-ESI calcd for $\text{C}_{20}\text{H}_{18}\text{O}_3$ ($M+\text{H}^+$): 247.1135; found: 247.1123.

Crystallographic data for 114.

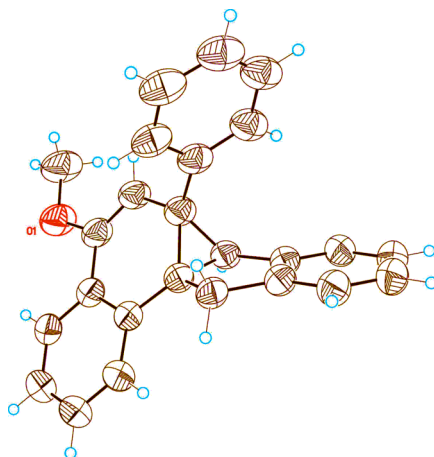

Identification code	SOAcIII119_0m	
Empirical formula	C ₂₅ H ₂₀ O	
Formula weight	336.41	
Temperature	293(2) K	
Wavelength	0.71073 Å	
Crystal system	Triclinic	
Space group	P-1	
Unit cell dimensions	a = 8.439 Å	α = 90.48 °.
	b = 9.432 Å	β = 90.52 °.
	c = 11.422 Å	γ = 96.99 °.
Volume	902.3 Å ³	
Z	2	
Density (calculated)	1.238 Mg/m ³	
Absorption coefficient	0.074 mm ⁻¹	
F(000)	356	
Crystal size	0.10 x 0.10 x 0.05 mm ³	
Theta range for data collection	1.78 to 25.39 °.	
Index ranges	-9 ≤ h ≤ 10, -11 ≤ k ≤ 5, -13 ≤ l ≤ 13	
Reflections collected	2557	
Independent reflections	1324 [R(int) = 0.0538]	

Completeness to theta =25.39 °	0.771 %
Absorption correction	Empirical
Max. and min. transmission	0.98 and 0.88
Refinement method	Full-matrix least-squares on F ²
Data / restraints / parameters	2557 / 266 / 236
Goodness-of-fit on F ²	1.919
Final R indices [I>2sigma(I)]	R1 = 0.1449 , wR2 = 0.3614
R indices (all data)	R1 = 0.2001 , wR2 = 0.3742
Largest diff. peak and hole	0.298 and -0.294 e.Å ⁻³

Bond lengths [Å] and angles [°]

Bond lengths

C1-C13	1.413(10)
C1-C4	1.421(11)
C1-C2	1.446(12)
C2-C3	1.320(10)
C2-O1	1.391(10)
C3-C11	1.484(11)
C4-C18	1.386(11)
C4-C8	1.487(10)
O1-C26	1.413(12)
C6-C7	1.388(10)
C6-C15	1.381(12)
C7-C12	1.384(12)
C7-C14	1.499(10)
C8-C10	1.527(11)
C8-C11	1.538(12)
C8-C14	1.538(11)

C9-C13	1.366(12)
C9-C16	1.388(13)
C10-C12	1.515(10)
C11-C17	1.512(10)
C11-C14	1.515(10)
C12-C20	1.370(11)
C15-C19	1.351(14)
C16-C18	1.375(10)
C17-C23	1.384(11)
C17-C21	1.383(11)
C19-C20	1.406(11)
C21-C22	1.381(10)
C22-C24	1.316(12)
C23-C25	1.375(11)
C24-C25	1.377(12)

Angles [°]

C13-C1-C4	118.3(8)
C13-C1-C2	121.9(8)
C4-C1-C2	119.9(6)
C3-C2-O1	124.8(8)
C3-C2-C1	123.5(8)
O1-C2-C1	111.5(6)
C2-C3-C11	122.5(8)
C18-C4-C1	118.6(7)
C18-C4-C8	121.7(8)
C1-C4-C8	119.6(8)
C2-O1-C26	116.8(7)
C7-C6-C15	118.4(9)
C6-C7-C12	120.5(7)

C6-C7-C14	128.1(8)
C12-C7-C14	111.4(7)
C4-C8-C10	120.4(7)
C4-C8-C11	117.9(7)
C10-C8-C11	115.7(6)
C4-C8-C14	120.8(6)
C10-C8-C14	107.7(5)
C11-C8-C14	59.0(5)
C13-C9-C16	120.7(8)
C12-C10-C8	104.8(6)
C3-C11-C17	112.8(7)
C3-C11-C14	114.9(6)
C17-C11-C14	123.1(6)
C3-C11-C8	115.9(6)
C17-C11-C8	120.2(7)
C14-C11-C8	60.5(5)
C20-C12-C7	120.8(7)
C20-C12-C10	128.2(8)
C7-C12-C10	111.0(7)
C9-C13-C1	120.9(9)
C7-C14-C11	118.6(6)
C7-C14-C8	104.9(7)
C11-C14-C8	60.5(5)
C19-C15-C6	121.3(8)
C18-C16-C9	119.2(9)
C23-C17-C21	117.5(7)
C23-C17-C11	119.2(7)
C21-C17-C11	123.3(7)
C16-C18-C4	122.2(9)
C15-C19-C20	120.9(9)
C12-C20-C19	118.1(9)

C22-C21-C17	120.3(8)
C24-C22-C21	121.4(9)
C25-C23-C17	121.0(8)
C22-C24-C25	120.3(8)
C23-C25-C24	119.5(9)

Torsion angles [°]

C13-C1-C2-C3	176.2(7)
C4-C1-C2-C3	-2.8(11)
C13-C1-C2-O1	0.5(10)
C4-C1-C2-O1	-178.5(6)
O1-C2-C3-C11	-178.7(7)
C1-C2-C3-C11	6.1(12)
C13-C1-C4-C18	-3.1(10)
C2-C1-C4-C18	176.0(7)
C13-C1-C4-C8	176.0(6)
C2-C1-C4-C8	-4.9(10)
C3-C2-O1-C26	6.2(12)
C1-C2-O1-C26	-178.1(7)
C15-C6-C7-C12	-1.0(11)
C15-C6-C7-C14	178.9(7)
C18-C4-C8-C10	-20.3(10)
C1-C4-C8-C10	160.6(6)
C18-C4-C8-C11	-172.1(6)
C1-C4-C8-C11	8.9(10)
C18-C4-C8-C14	119.2(9)
C1-C4-C8-C14	-59.9(9)
C4-C8-C10-C12	141.2(6)
C11-C8-C10-C12	-66.5(7)
C14-C8-C10-C12	-3.0(8)

C2-C3-C11-C17	-145.7(8)
C2-C3-C11-C14	66.2(10)
C2-C3-C11-C8	-1.6(11)
C4-C8-C11-C3	-5.7(10)
C10-C8-C11-C3	-158.7(6)
C14-C8-C11-C3	105.3(7)
C4-C8-C11-C17	135.6(7)
C10-C8-C11-C17	-17.4(9)
C14-C8-C11-C17	-113.4(7)
C4-C8-C11-C14	-111.0(7)
C10-C8-C11-C14	96.0(6)
C6-C7-C12-C20	1.7(12)
C14-C7-C12-C20	-178.2(7)
C6-C7-C12-C10	-176.6(6)
C14-C7-C12-C10	3.5(9)
C8-C10-C12-C20	-178.3(8)
C8-C10-C12-C7	-0.2(8)
C16-C9-C13-C1	0.6(11)
C4-C1-C13-C9	0.9(10)
C2-C1-C13-C9	-178.1(7)
C6-C7-C14-C11	-120.9(9)
C12-C7-C14-C11	59.0(10)
C6-C7-C14-C8	174.9(7)
C12-C7-C14-C8	-5.2(8)
C3-C11-C14-C7	161.6(8)
C17-C11-C14-C7	17.1(13)
C8-C11-C14-C7	-91.6(8)
C3-C11-C14-C8	-106.9(7)
C17-C11-C14-C8	108.7(9)
C4-C8-C14-C7	-139.1(7)
C10-C8-C14-C7	4.9(7)

C11-C8-C14-C7	114.8(6)
C4-C8-C14-C11	106.1(8)
C10-C8-C14-C11	-109.9(6)
C7-C6-C15-C19	0.7(13)
C13-C9-C16-C18	0.0(11)
C3-C11-C17-C23	71.3(10)
C14-C11-C17-C23	-143.6(9)
C8-C11-C17-C23	-71.2(9)
C3-C11-C17-C21	-106.5(9)
C14-C11-C17-C21	38.6(13)
C8-C11-C17-C21	111.0(10)
C9-C16-C18-C4	-2.3(11)
C1-C4-C18-C16	3.8(11)
C8-C4-C18-C16	-175.2(7)
C6-C15-C19-C20	-1.1(14)
C7-C12-C20-C19	-1.9(12)
C10-C12-C20-C19	176.1(7)
C15-C19-C20-C12	1.6(13)
C23-C17-C21-C22	0.6(13)
C11-C17-C21-C22	178.4(9)
C17-C21-C22-C24	0.3(14)
C21-C17-C23-C25	-0.6(13)
C11-C17-C23-C25	-178.5(9)
C21-C22-C24-C25	-1.1(15)
C17-C23-C25-C24	-0.2(14)
C22-C24-C25-C23	1.1(15)

References

1. (a) Amjís, C. H. M.; López-Carrillo, V.; Raducan, M.; Pérez-Galán, P.; Ferrer, C.; Echavarren, A. M. *J. Org. Chem.* **2008**, *73*, 7721-7730. (b) Ferrer, C.; Raducan, M.; Nevado, C.; Claviere, C.K.; Echavarren, A. *Tetrahedron* **2007**, *63*, 6306-6316.
2. He, Z.; Yudin, A. K. *Org. Lett.* **2006**, *8*, 5829-5832.
3. Corkum, E.; Hass, M. J.; Sullivan, A. D.; Andrew, D.; Bergens, S. H. *Org. Lett.* **2011**, *13*, 3522-3525.
4. Panda, B.; Tarun, K. *Chem. Commun.* **2010**, *46*, 3131-3133.
5. Fabrizi, G.; Goggiamani, A.; Sferrazza, A.; Chacchi, S. *Angew. Chem. Int. Ed.* **2010**, *49*, 4067-4070.
6. Lee, H. W.; Lee, L. N.; Chan, A. S. C.; Kwong, F. Y. *Eur. J. Org. Chem.* **2008**, *19*, 3403-3406.
7. Kleinbeck, F.; Toste, F. D. *J. Am. Chem. Soc.* **2009**, *131*, 9178-9179.
8. Jiménez-Núñez, E.; Raducan, M.; Lauterbach, T.; Molawi, K.; Solorio, C. R.; Echavarren, A. M. *Angew. Chem. Int. Ed.* **2009**, *48*, 6152-6155.
9. Nanayakkara, P.; Alper, H. *Adv. Syn. Catal.* **2006**, *348*, 545-550.
10. Wei, W.; Hamamoto, Y.; Ukaji, Y.; Inomata, K. *Tetrahedron: Asymmetry* **2008**, *19*, 476-481.
11. Togninelli, A.; Gevariya, H.; Alongi, M.; Botta, M. *Tetrahedron Lett.* **2007**, *48*, 4801-4803.
12. Zheng, W.; Degterev, A.; Hsu, E.; Yuan, J.; Yuan, C. *Bioorg. Med. Chem. Lett.* **2008**, *18*, 4932-4935.
13. Tretyakov, E. V.; Tkachev, A. V.; Rybalova, T. V.; Gatilov, Y. V.; Knight, D. W.; Vasilevsky, S. F. *Tetrahedron* **2000**, *56*, 10075-10080.
14. Tsuchida, S.; Kaneshige, A.; Ogata, T.; Baba, H.; Yamamoto, Y.; Tomioka, K. *Org. Lett.* **2008**, *10*, 3635-3638.

15. Miura, M.; Akase, F.; Shinohara, M.; Nomura, M. *J. Chem. Soc. Perk. Trans. I* **1987**, *5*, 1021-10255.
16. Koltunov, K. Yu.; Repinskaya, I. B.; Shakirov, M. M.; Shchegoleva, L. *N. Z. Org. Khim.* **1994**, *30*, 82-90.
17. Sugawara, M.; Yoshida, J. *J. Am. Chem. Soc.* **1997**, *119*, 11986-11987.
18. Creary, X. *Organic Syntheses* **1998**, *7*, 438-444.
19. Ishikawa, T.; Saito, T.; Ishii, H. *Tetrahedron* **1995**, *51*, 8447-8458.
20. Barrero, A. F.; Alvarez-Manzaneda, E. J.; Chahboun, R. *Tetrahedron* **1998**, *54*, 5635-5650.
21. Jung, M. E.; Lam, Patrick, Y. S.; Mansuri, M. M.; Speltz, L. M. *J. Org. Chem.* **1985**, *50*, 1087-1095.
22. Liron, F.; Fontana, F.; Zirimwabagabo, J.; Prestat, G.; Rajabi, J.; La Rosa, C.; Poli, G. *Org. Lett.* **2009**, *11*, 4378-4381.
23. Zhan, Z.; Yu, J.; Liu, H.; Cui, Y.; Yang, R.; Yang, W.; Li, J. *J. Org. Chem.* **2006**, *71*, 8298-8301.
24. D. Srimani, A. Sarkar, *Tetrahedron Lett.* **2008**, *49*, 6304-6307.
25. Kobayashi, O.; Uraguchi, D.; Yamakawa, T. *Org. Lett.* **2009**, *11*, 2679-2682.
26. Guan, B.-T.; Lu, X.-Y.; Zheng, Y.; Yu, D.-G.; Wu, T.; Li, K.-L.; Li, B.-J.; Shi, Z.-J. *Org. Lett.* **2010**, *12*, 396-399.
27. Wipf, P.; Jung, J.-K. *J. Org. Chem.* **2000**, *65*, 6319-6337.
28. Kuroda, J.; Inamoto, K.; Hiroya, K.; Doi, T. *Eur. J. Org. Chem.* **2009**, *14*, 2251-2261.
29. Zhang, L.; Qing, J.; Yang, P.; Wu, J. *Org. Lett.* **2008**, *10*, 4971-4974.
30. Zhang, T.-K.; Mo, D.-L.; Dai, L.-X.; Hou, Xue-Long. *Org. Lett.* **2008**, *10*, 5337-5340.

31. Tobisu, M.; Shimasaki, T.; Chatani, N. *Angew. Chem. Int. Ed.* **2008**, *47*, 4866-4869.
32. Kraus, G. A.; Choudhury, P. K. *Synlett* **2004**, 97-98.
33. Lewis, K. D.; Matzger, A. J. *J. Am. Chem. Soc.* **2005**, *127*, 9968-9969.

CHAPTER III

Development of the Gold(I)-Catalyzed Retro-Buchner Reaction.

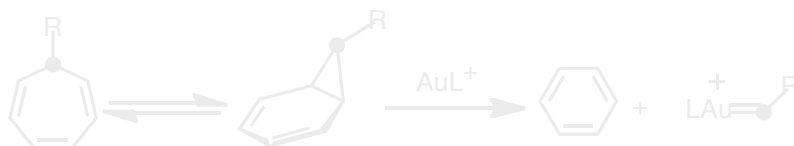

UNIVERSITAT ROVIRA I VIRGILI
GOLD (I)-CATALYZED RETRO-CYCLOPROPANATION REACTION AND DEVELOPMENT OF TRINDANE-BASED
APPROACH TOWARD C60
Cesar Rogelio Solorio Alvarado
DL: T. 1714-2011

CHAPTER III

Introduction

Cyclopropanations reactions of alkenes are one of the most studied reactions in chemistry. Generally are carried out using 1,1-diiodoalkanes and Zn, the Simmons-Smith procedure (S-S)¹⁸⁷ or Et₂Zn, the Furukawa modification of the Simmons-Smith reaction (Equation 3.1).¹⁸⁸

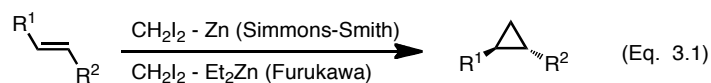

Following the pioneering work of Wittig with diazomethane,¹⁸⁹ diazo derivatives have been extensively used in the presence of different metal-based catalysts for the cyclopropanation reaction of alkenes (Equation 3.2).¹⁹⁰

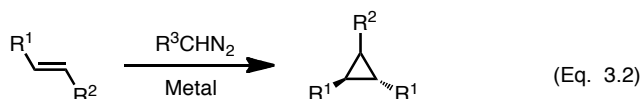

The use of diazo derivatives in presence of a metal catalyst is one of the most extensively used procedures for cyclopropanation. Thus a bigger amount of functional groups coming from diazo derivatives can be incorporated into the cyclopropane. Cyclopropanation by metal-catalyzed decomposition of diazo compounds needs the choice of the proper catalyst depending if the reaction is intra- or intermolecular as well as the electronic nature of the diazo derivative.

187 Simmons, H. E.; Smith, R. R. *J. Am. Chem. Soc.* **1958**, *80*, 523

188 (a) Furukawa, J.; Kawabata, N.; Nishimura, J. *Tetrahedron Lett.* **1966**, *7*, 3353. (b) Use of EtZnI: Inouye, Y.; Swada, S. *Bull. Chem. Soc. Jpn.* **1969**, *42*, 2669.

189 Wittig, G.; Schwarzenbach, K. *Angew. Chem.* **1959**, *71*, 652.

190 (a) Forbes, D. C.; Doyle, M. P. *Chem. Rev.* **1998**, *98*, 911-935. (b) See ref. 177.

These can be neutral, with one or two electron-withdrawing groups and with aryl or vinyl derivatives (Scheme 3.1).

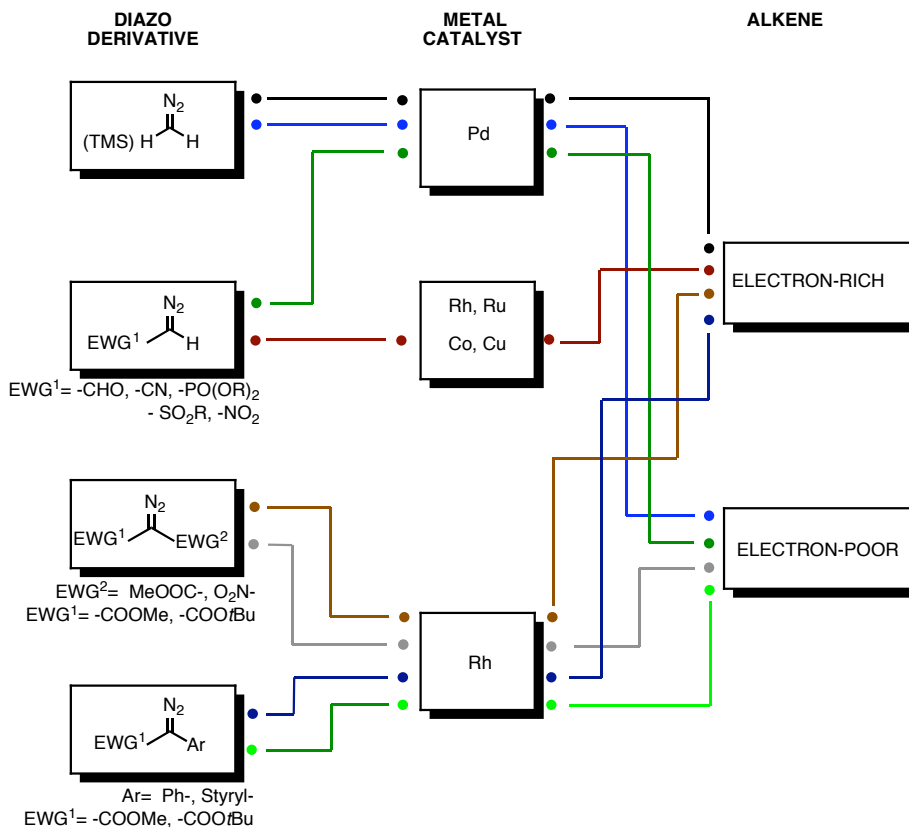

Scheme 3.1. Optimal choice of metal source for cyclopropanation with diazo derivatives according to their electronic nature.

Cyclopropanation with diazo methane, intra- or intermolecularly needs of a palladium catalyst to give best results (Scheme 3.1., black line). Diazo compounds with one α -electron-withdrawing group, cyclopropanate intermolecularly electron-rich olefins in presence of Rh(II),¹⁹¹ Ru(II),¹⁹²

191 Hoberg, J.; Claffey, D. J. *Tetrahedron Lett.* **1996**, *37*, 2533-2539.

192 Park, S. W.; Son, J. H.; Kim, S. G.; Ahn, K. H. *Tetrahedron Asymmetry* **1999**, *10*, 1903-1911.

Co(III),¹⁹³ and Cu(I) (Scheme 3.1., red line),¹⁹⁴ while Pd(0) is the most efficient metal with electron-poor alkenes (Scheme 3.1., dark green line). Diazo compounds containing two electron-withdrawing groups are considerably less reactive. However they can cyclopropanate intermolecularly electron-rich olefins (Scheme 3.1., brown line) as well as electron-poor olefins using a Rh(II) catalyst (Scheme 3.1., gray line).¹⁹⁵ Additionally Rh(II)-based catalyst are successfully used in the intermolecular cyclopropanation of electron-rich olefins (Scheme 3.1., dark blue line) as well as electron-poor olefins (Scheme 3.1., light green line) with diazo compounds bearing one electron-withdrawing group and a styryl or aryl group.

Additionally diazo derivatives have also been commonly used for the cyclopropanation of alkenes in the presence of some other metal catalysts (Ni, Fe, Zn, U, Os)¹⁹⁶ including gold(I)¹⁹⁷ (Equation 3.3).

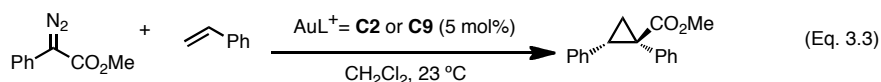

However, it is important to mention that diazo compounds are potentially explosive compounds.

Alternative to S-S and metal-catalyzed decomposition of diazo derivatives, cyclopropanation reaction catalyzed by transition metals has been developed without the use of diazo compounds. Cyclopropanation via gold(I)-carbenes has been reported from cyclopropenes¹⁹⁸ and propargylic carboxylates (Equation

193 Chen, Y.; Ruppel, V.; Zhang, X. *J. Am. Chem. Soc.* **2007**, *129*, 938-941.

194 Fritschi, H.; Leutenegger, U.; Pfaltz, A. *Angew. Chem. Int. Ed.* **1986**, *25*, 1005-1008.

195 Doyle, M. P.; Davis, S. B.; Hu, W. *Org. Lett.* **2000**, *2*, 1145-1148.

196 (a) Forbes, D. C.; Doyle, M. P. *Chem. Rev.* **1998**, *98*, 911-935. (b) Lebel, H.; Marcoux, J-F.; Molinaro, C.; Charette, A. B. *Chem. Rev.* **2003**, *103*, 977-1050. (c) Lindsay, V. N. G.; Nicolas, C.; Charette, A. B. *J. Am. Chem. Soc.* **2011**, *133*, 8972-8981.

197 Prieto, A.; Frutos, M. R.; Díaz-Requejo, M. M.; Pérez, P. J.; Pérez-Galán, P.; Delpont, N.; Echavarren, A. M. *Tetrahedron* **2009**, *65*, 1790-1793.

198 Review: Miege, F.; Meyer, C.; Cossy, C. *Beilstein J. Org. Chem.* **2011**, *7*, 717-734.

3.4),¹⁹⁹ vinyl allenes (Equation 3.5),²⁰⁰ 1,5-enynes or allenynes with concomitant sp^3 C-H bond insertion (Equation 3.6),²⁰¹ and cycloisomerization of 1,6-enynes and trapping with olefin (Equation 3.7).^{40a}

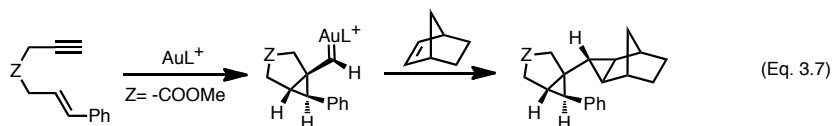
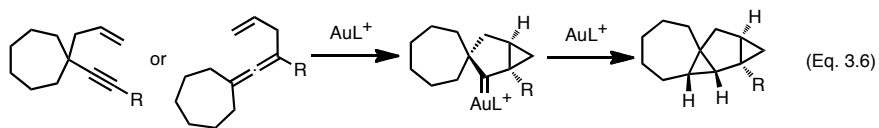
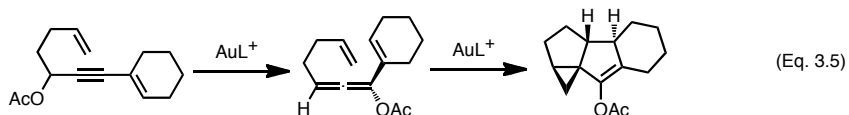
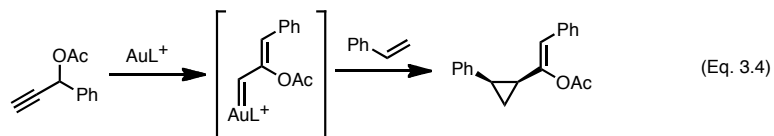

Transition metal-free cyclopropanation without the use of diazo derivatives has been also described. This class of transformations involves the conjugate addition to an electrophilic alkene to form an enolate, which undergoes an intramolecular ring closure leading to cyclopropane.

199 Johansson, M. J.; Gorin, D. J.; Staben, S. T.; Toste, F. D. *J. Am. Chem. Soc.* **2005**, *127*, 18002-18003. (b) Gorin, D. J.; Watson, I. D. G.; Toste, F. D. *J. Am. Chem. Soc.* **2008**, *130*, 3736-3737.

200 (a) Lemière, G.; Gandon, V.; Cariou, K.; Fukuyama, T.; Dhimane, A.-L.; Fensterbank, L.; Malacria, M. *Org. Lett.* **2007**, *9*, 2207-2209. (b) Lemière, G.; Gandon, V.; Cariou, K.; Hours, A.; Fukuyama, T.; Dhimane, A.-L.; Fensterbank, L.; Malacria, M. *J. Am. Chem. Soc.* **2009**, *131*, 2993-3006.

201 Horino, Y.; Yamamoto, T.; Ueda, K.; Kuroda, S.; Toste, F. D. *J. Am. Chem. Soc.* **2009**, *131*, 2809-2811.

These reactions are defined as Michael-initiated ring closure reactions (MIRC).

Two classes of substrates can be used in MIRC reactions. The first class allows the access to the cyclopropane ring by nucleophilic addition to electrophilic alkene containing a leaving group (Equation 3.8, v.g. 3.8a).²⁰²

The second class of substrates that participate in MIRC are those in which the leaving group is present on the nucleophile (Equation 3.9, v.g. 3.9a).

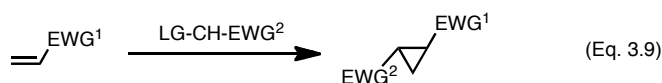
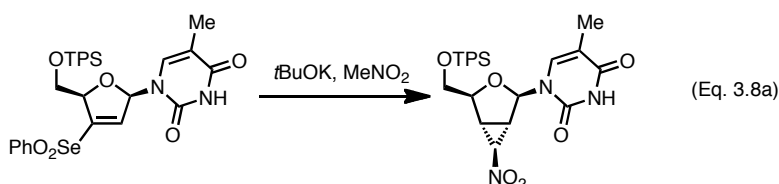
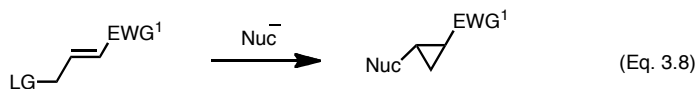

The second class of MIRC reactions has been the most studied. A wide variety of nucleophiles can be used, such as alcoxides, thiolates, cyanides, enolates, Grignard reagents, hydrides, phosphites, and phosphines.²⁰³

Gold(I)-catalyzed cyclization of 1,*n*-enynes proceeds through intermediates that can be viewed as highly distorted gold(I) carbenes,¹⁶⁴ which can be trapped by alkenes intra- or intermolecularly in cyclopropanation reactions.^{204,205}

202 Caine, D. *Tetrahedron* **2001**, *57*, 2643-2648.

203 Li, J.; Liu, Y.-C.; Deng, J.-G. *Tetrahedron Asym.* **1999**, *10*, 4343-4348.

In this Doctoral Thesis we found an example of a gold(I)-promoted retro-cyclopropanation in the context of a synthesis of 1,3-disubstituted naphthalenes (chapter II).²⁰⁶

Based on these results, we envisioned that the formation of free gold carbenes, could come from a retro-cyclopropanation reaction, and could be generated in modular way, by using 7-substituted cycloheptatrienes that are in equilibrium with their norcaradiene tautomer.

7-Substituted 1,3,5-cycloheptatrienes **118** (CHT),²⁰⁷ which are in equilibrium with norcaradienes **119** (NCD),²⁰⁸ reacted with cationic gold(I) catalysts to generate in situ gold(I) carbenes **120** that cyclopropanate alkenes (Scheme 3.2). In this retrocyclopropanation we expected that two C-C could be cleaved in **119** by Au(I). This is in contrast with that observed in the presence of strong electrophiles such as TeCl₄, which cleave a single C-C bond of **119** leading to benzylic chlorides.^{209,210,211,212}

204 (a) See ref. 40a. (b) Nieto-Oberhuber, C.; López, S.; Muñoz, M. P.; Jiménez-Núñez, E.; Buñuel, E.; Cárdenas, D. J.; Echavarren, A. M. *Chem. Eur. J.* **2006**, *12*, 1694-1702. (c) See ref. 99. (d) See ref. 164.

205 Kim, S. M.; Park, J. H.; Choi, S. Y.; Chung, Y. K. *Angew. Chem. Int. Ed.* **2007**, *46*, 6172-6175.

206 Solorio-Alvarado, C. R.; Echavarren, A. M. *J. Am. Chem. Soc.* **2010**, *132*, 11881-11883.

207 Picotin, G.; Faye, A.; Miginac, P. *Bull. Soc. Chim. Fr.* **1990**, *127*, 245-251.

208 (a) Daub, J.; Lüdemann, H.-D.; Michna, M.; Strobl, R. M. *Chem. Ber.* **1985**, *118*, 620-633. (b) McNamara, O. A.; Maguire, A. R. *Tetrahedron* **2011**, *67*, 9-40.

209 Albeck, M.; Tamari, T.; Sprecher, M. *J. Org. Chem.* **1983**, *48*, 2276-2278.

210 Formation of benzyl-Rh(II) from cycloheptatrienyl-Rh(I) by a metalloradical process: Cahn, Y. W.; Chan, K. S. *Chem. Commun.* **2011**, *47*, 4802-4804.

211 Reaction of 7-ethynylcyclohepta-1,3,5-triene with trifluoroacetic acid gives phenylallene by protonation of the alkyne in the norcaradiene tautomer, followed by cyclopropane cleavage to form the arenium cation: (a) Kitagawa, T.; Kamada, J.; Minegishi, S.; Takeuchi, K. *Org. Lett.* **2000**, *2*, 3011-3013. (b) Minegishi, S.; Kamada, J.; Takeuchi, K.; Komatsu, K.; Kitagawa, T. *Eur. J. Org. Chem.* **2003**, 3497-3504.

212 2-Ethoxyethylidene carbene has been generated by photochemical cleavage of a cyclopropanated phenanthrene: Graves, K. S.; Thamattoor, D. M.; Rablen, P. R. *J. Org. Chem.* **2011**, *76*, 1584-1591.

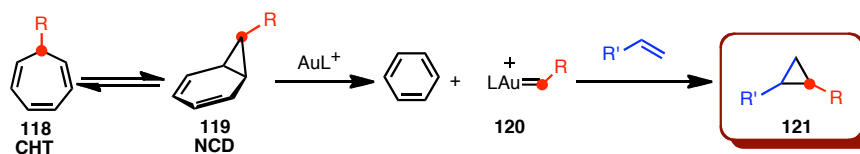

Scheme 3.2. Formation of free gold(I) carbenes by retro-cyclopropanation of norcaradienes.

In this new catalytic process, norcaradiene **119** can be considered as surrogate of a diazo compound²¹³ constituting a safer alternative as carbene precursors.²¹⁴ Interestingly the reverse process, the Buchner reaction for the formation of cycloheptatrienes, occurs as a side reaction in the gold(I)-catalyzed cyclopropanation between ethyl diazoacetate and arenes.²¹⁵

Results and discussion

Our study started with the synthesis of 7-aryl cycloheptatrienes. 7-Substituted 1,3,5-cycloheptatrienes **118a-j** were easily prepared in one step by the addition of organolithium or Grignard reagents to commercially available tropylium tetrafluoroborate **117** (Scheme 3.2).²¹⁶

213 (a) Phenyl diazomethane is explosive at room temperature and should be stored between -20 and -80 °C under N₂ or Ar: Creary, X. *Org. Synth.* **1986**, *64*, 207-216. (b) Electron-rich *p*-methoxyphenyl diazomethane is shock-sensitive, and can detonate. It slowly decomposes at -80 °C: Closs, G. L.; Moss, R. A. *J. Am. Chem. Soc.* **1964**, *86*, 4042-4053.

214 Use of tosylhydrazone salts as a safe alternative for handling diazo compounds: (a) Aggarwal, V. K.; Alonso, E.; Fang, G. Y.; Ferrara, M.; Hynd, G.; Porcelloni, M. *Angew. Chem. Int. Ed.* **2001**, *40*, 1433-1436. (b) Fulton, J. R.; Aggarwal, V. K.; de Vicente, J. *Eur. J. Org. Chem.* **2005**, 1479-1492.

215 (a) Rivilla, I.; Gómez-Emeterio, P.; Fructos, M. R.; Díaz-Requejo, M. M.; Pérez, P. J. *Organometallics* **2011**, *30*, 2855-2860. (b) See ref. 175.

216 Picotin, G.; Faye, A.; Miginiac, P. *Bull. Soc. Chim. Fr.* **1990**, *127*, 245-251.

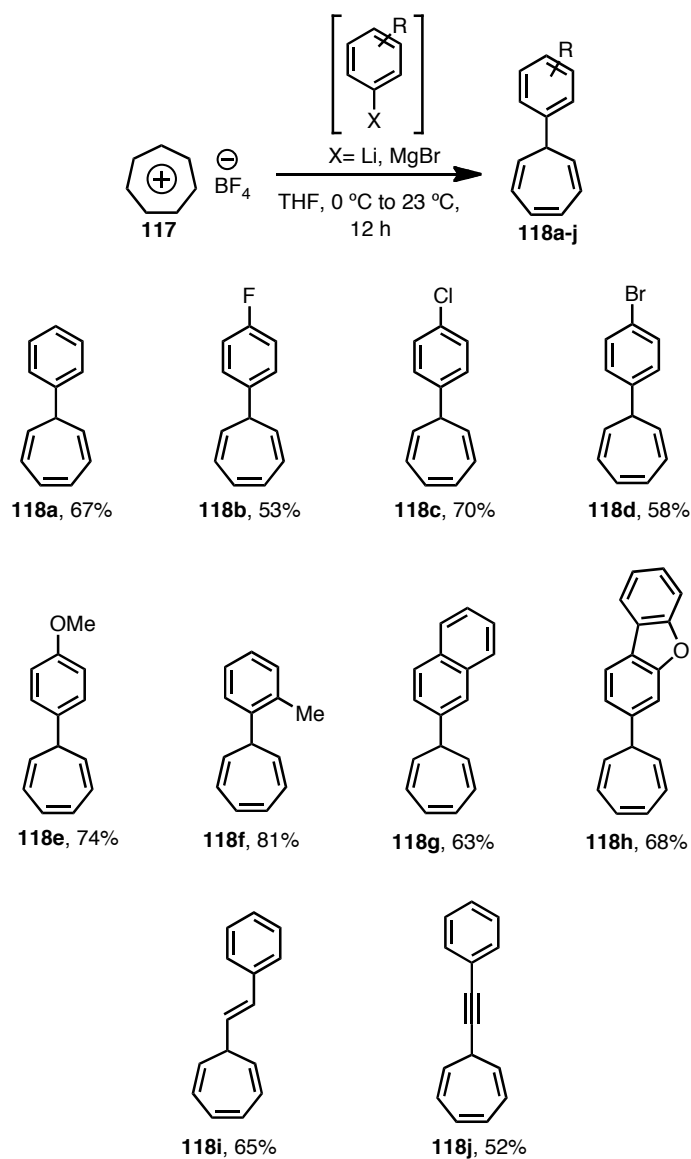
**Scheme 3.2.** Synthesis of 7-aryl 1,3,5-cycloheptatrienes **118a-i**

Once cycloheptatrienes **118a-i** were synthesized we first studied the reaction between 7-phenyl-1,3,5-cycloheptatriene and *trans*-stilbene with different Au(I) catalysts **C1-C5** (Table 3.1).

Table 3.1. Gold(I)-Catalyzed Cyclopropanation of *trans*-Stilbene with Cycloheptatriene **118a**.

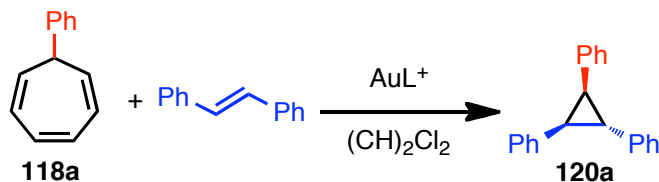

entry	[Au] (mol%)	T (°C)	Time (h)	120a (yield, %)
1	C1 (5)	80	8	26
2	C1 (5)	100	5	31
3	C1 (10)	100	5	33
4	C2 (5)	80	8	49
5	C2 (5)	100	5	73
6	C2 (5)	120	2.25	84
7	C3 (5)	80	8	5
8	C3 (5)	100	8	7
9	C4 (5)	80	10	- ^a
10	C5 (5)	80	8	43
11	C5 (10)	100	5	64
12	C5 (5)	120	1.75	70

^a No reaction was observed.

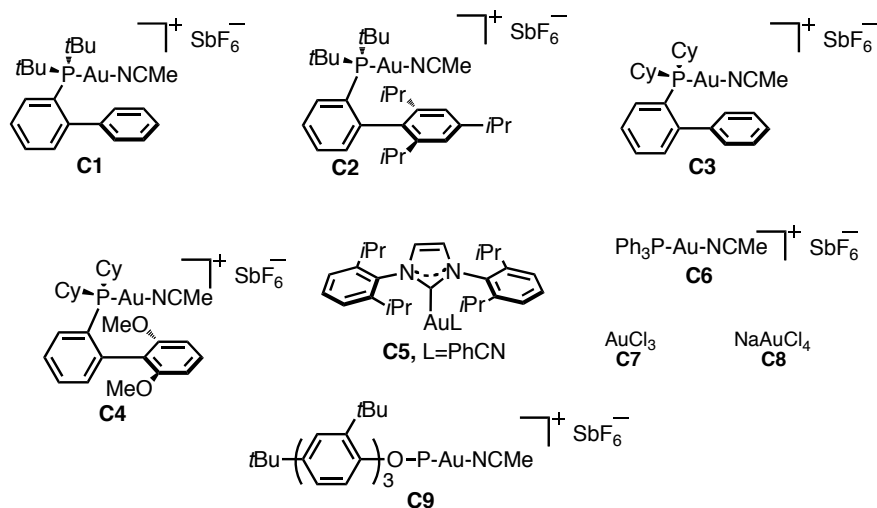

No reaction was observed with $[\text{Au}(\text{PPh}_3)(\text{MeCN})]\text{SbF}_6$ at 23–80 °C. However, when the reaction was carried out in 1,2-dichloroethane at 80–100 °C with catalyst **C1**, 1,2,3-triphenylcyclopropane **120a** was obtained in 26–33% yield (Table 1, entries 1–3). The best yield (73–84%), was obtained using catalyst **C2** with a more sterically hindered phosphine ligand (Table 3.1, entries 5 and 6). Catalysts **C3** and **C4** did not performed satisfactorily, whereas complex **C5** with a bulky NHC ligand gave **120a** in slightly lower yields (43–70%) than **C2** (Table 3.1, entries 10–12). Many other solvents like dichloromethane, chloroform, carbon tetrachloride or benzene, were tested. Different temperatures ranging from 23 °C to 120 °C were tested as well, however no reaction or poor yields were obtained.

At this point, 5 mol% of **C2**, 2–3 equiv of **118a**²¹⁷ in 1,2-dichloroethane at 120 °C were the optimal conditions.

To explore the generality of this method we studied the reaction with *trans*-stilbene and cycloheptatrienes **118b–e** and **118g**. Cyclopropanes **120b–f**²¹⁸ were

217 For this specific case in the cyclopropanation of *trans*-stilbene, the use of 2–3 equiv of the corresponding cycloheptatriene was necessary. The general procedure in the rest of examples involves an excess of the olefin.

218 Cyclopropane **120f** was synthesized in collaboration with Yahui Wang.

obtained in good yields (61-91%) as single stereoisomers (Scheme 3.3). The reaction times in this cyclopropanation reaction oscillates between 2-3 hours, however we will find that longer reaction times in general should be necessary to complete the reaction.

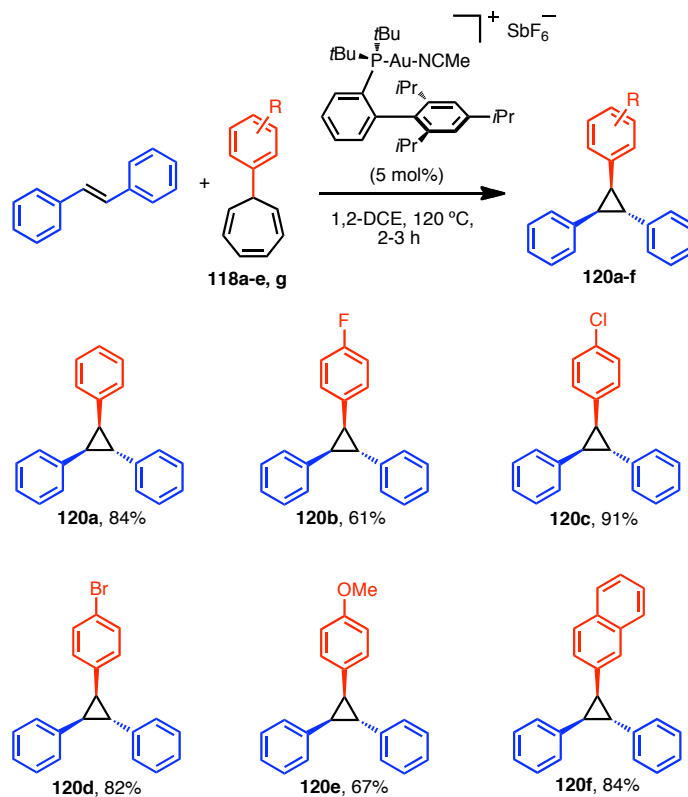

Scheme 3.3. Cyclopropanation of *trans*-stilbene with 118a-e, g.

The scope of the reaction was expanded by using a variety of electron-rich and electron-poor styrenes. When these substituted styrenes were employed as the starting materials, the corresponding cyclopropanes were isolated with moderate to good *trans/cis* stereoselectivities being the *trans* isomer the major product of the reaction.

Only 7-*p*-methoxyphenyl-1,3,5-cycloheptatriene **118c** reacted to form **120h**, **120l-m**, **120o-p** and **120t** as 1-4:1 *trans/cis* mixtures of isomers (scheme 3.4).

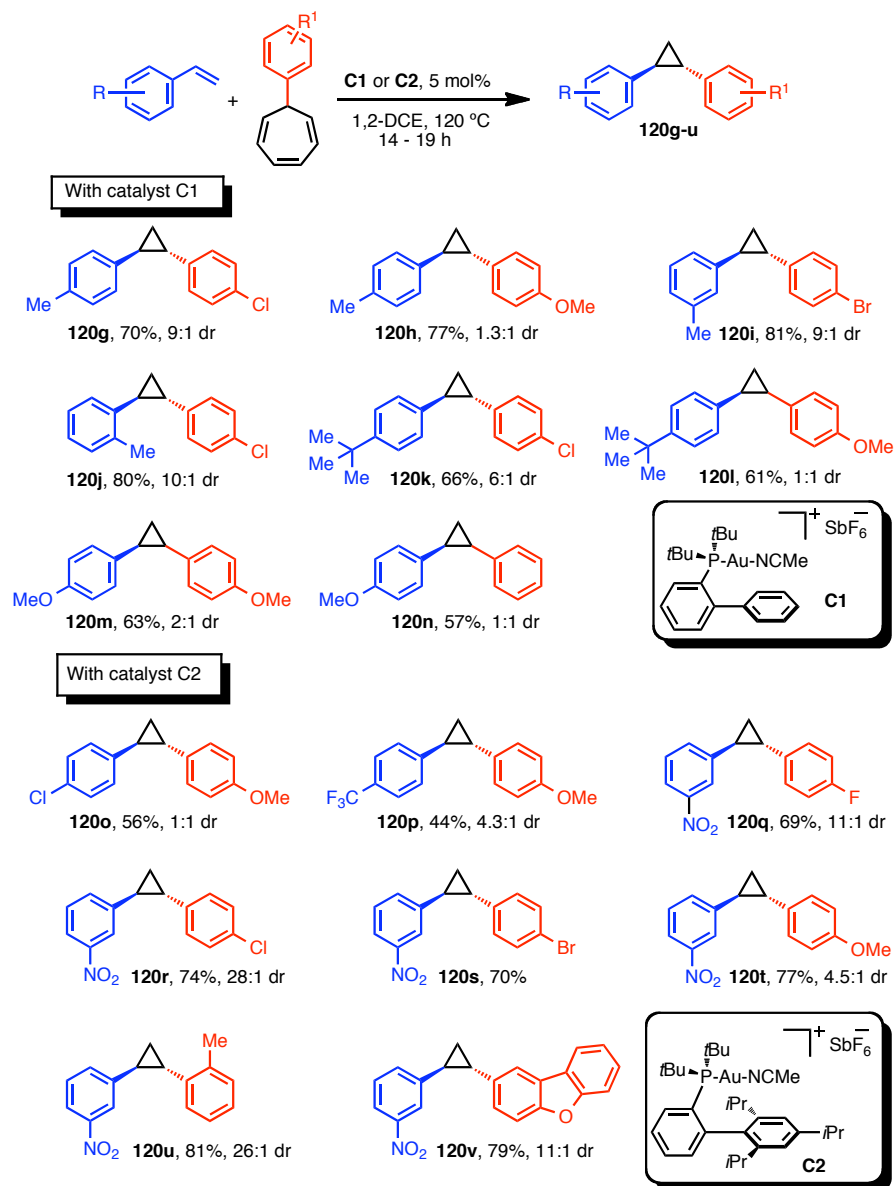

Scheme 3.4. Scope of intermolecular cyclopropanation via free benzyliden gold(I) carbenes.

Electron-rich styrenes gave cyclopropanation products **120g-n**, as well as electron-poor styrenes that gave cyclopropanes **120o-v**. Reaction times range between 14-19 h using a slight excess of the alkene (1.5-2 equiv).

It is worth to mention that catalyst **C2** was highly active in the polymerization of electron-rich styrenes, which took place within 5 min at 120 °C. However active catalyst **C1** was useful in this cyclopropanation reaction for the electron-rich styrenes. Presumably, the steric hinderance favor conformation **C2-Styr-2** with a less stabilized cation structure, initiating the polymerization process (example for 4-methoxystyrene) (Scheme 3.5).

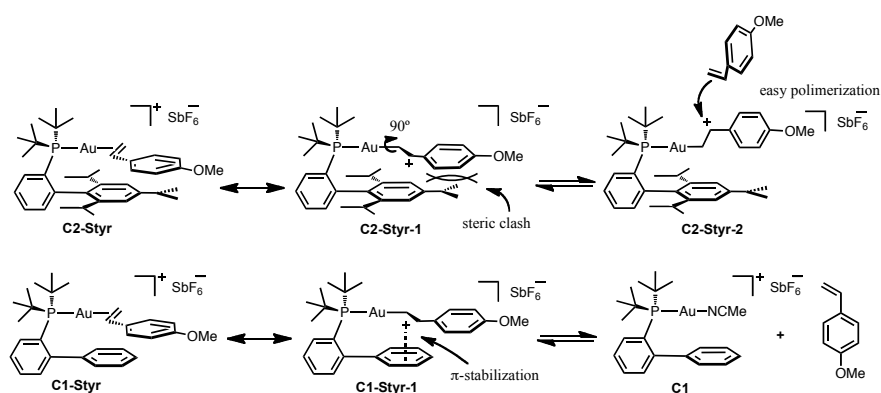

Scheme 3.5. Explanation for the observed polymerization of electron-rich styrenes with **C2** and not observed with **C1** in the cyclopropanation reaction.

On the other hand in less sterically hindered **C1-Styr** the cation center is more stabilized by a π -interaction with the phenyl substituent.²¹⁹

Thus, catalyst **C2** would be the optimal catalyst when electron-poor styrenes were reacted. Contrarily, catalyst **C1** would be employed for the reaction of electron-rich styrenes. Nevertheless, **C1** catalyzed the cyclopropanation reaction of electron-poor styrenes, however longer reaction times or higher loading (up to 10 mol%) were required to obtain satisfactory results.

219 (a) Brown, T. J.; Dickens, M. G.; Widenhoefer, R. A. *Chem. Commun.* **2009**, 6451-6453. (b)

Brown, T. J.; Dickens, M. G.; Widenhoefer, R. A. *J. Am. Chem. Soc.* **2009**, *131*, 6350-6351.

An interesting result in this reactions is the low stereoselectivities observed with the use of *p*-methoxyphenyl cycloheptatriene that generates *p*-methoxybenzyl gold(I) carbene. A possible explanation is that this carbene is more planar because the conjugation, which diminish the steric repulsions in **TS-B** that leads to *cis*-cyclopropane (Scheme 3.6).

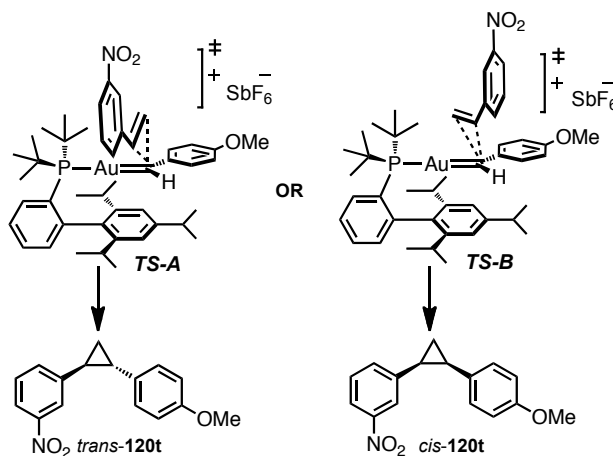

Scheme 3.6. Transitions states to explain the stereoselectivity in the cyclopropanation with *p*-methoxybenzyl gold(I) carbene.

The *trans* geometry of *trans*-**120t** was unambiguously assigned by X-ray diffraction (Figure 3.1)

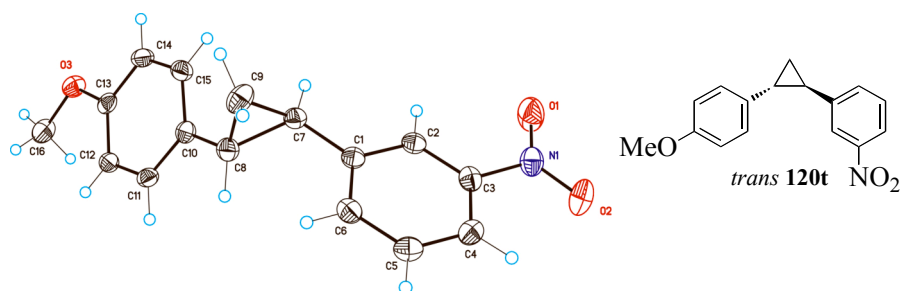
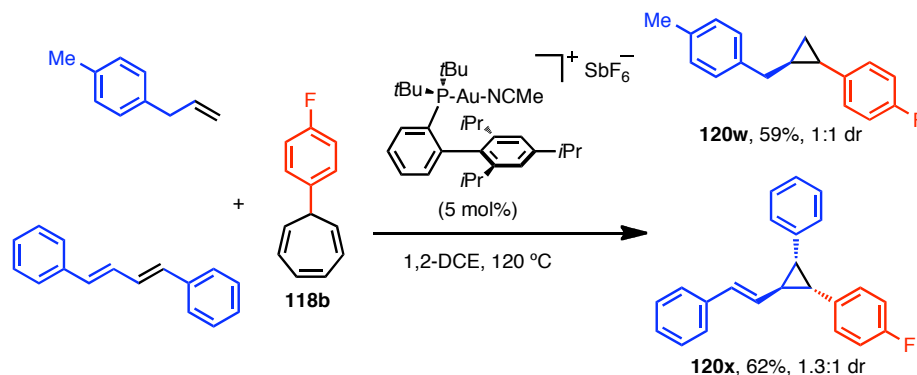

Figure 3.1. Confirmation of *trans* selectivity in the cyclopropanation by X-ray structure of **120t**.

The reaction also proceeded with 1-allyl-4-methylbenzene to give **120w** in 59% yield as 1:1 mixture of diastomers. In the case of (*E,E*)-1,4-diphenyl-1,3-butadiene, only the monoadduct **120x** could be obtained in 62% yield with 1.3:1 dr (Scheme 3.7).



Scheme 3.7. Cyclopropanation of allyl toluene and *trans* 1,4-diphenylbutadiene with **118b**.

To confirm the structure of **120x**, we decide to cleavage the double bond. Thus, ozonolysis gave the corresponding aldehyde **120y** in 46% yield. Extensive NMR analysis unequivocally confirmed the relative stereochemistry of the major diastereoisomer (Scheme 3.8).

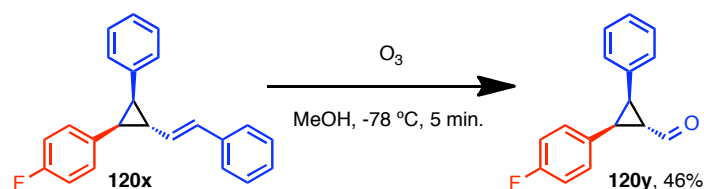

Scheme 3.8. Ozonolysis of **120x** to confirm its relative configuration.

The cyclopropanation using vinyl cycloheptatriene **118i** provided **120z** in 39% yield using catalyst **C1** (Equation 3.10).

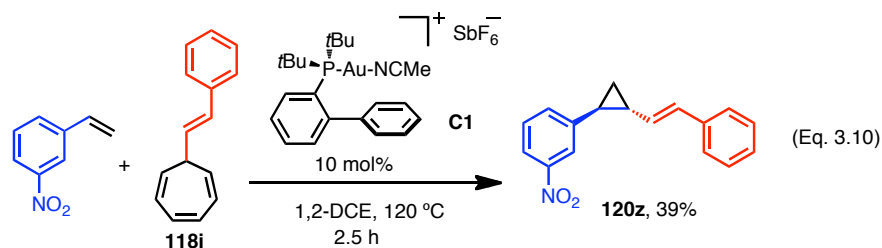

The cyclopropanation of 6-chloro-1*H*-indene with **118a**, **118d**, and **118e** led selectively to *exo*-tetrahydrocyclopropa[*a*]indenes **120aa-ac**²²⁰ (Scheme 3.9).

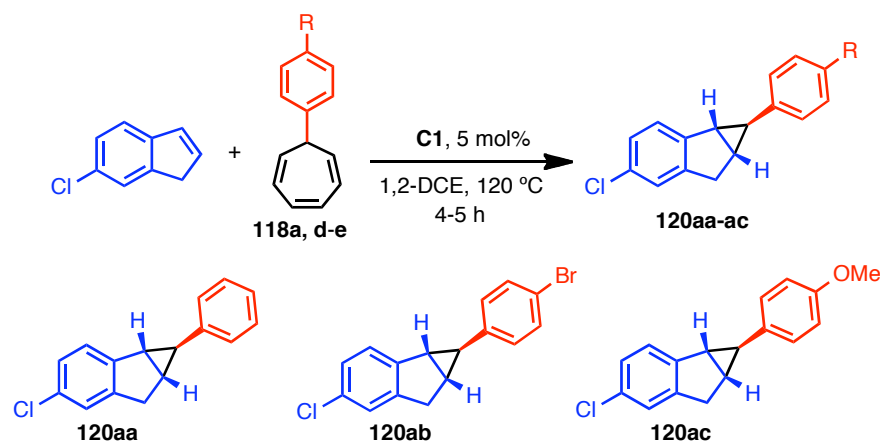

Scheme 3.9. Additional cyclopropanes synthesized via free gold(I) carbenes.

This new cyclopropanation was useful in the synthesis of trisubstituted cyclopropanes. Thus cyclopropanation of *trans*- β -methyl styrene lead to the formation of **120ad** (62%, 4:1 dr) and **120ae** (67%, 3.2:1 dr) with modest diastereoselectivity (Scheme 3.10).

²²⁰ Cyclopropanes **120z** and **120aa-ac** were synthesized in collaboration with Yahui Wang.

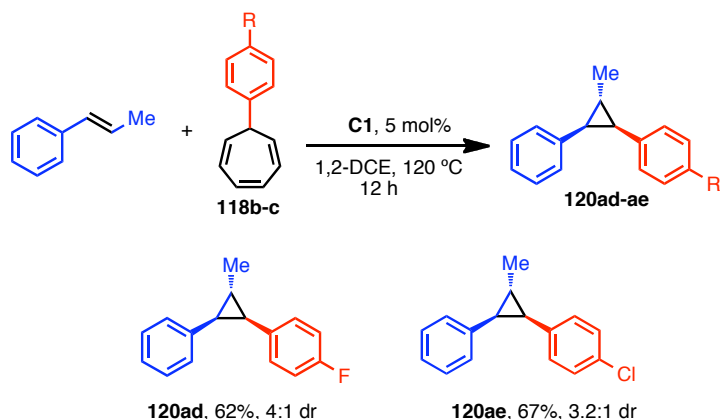

Scheme 3.10. Synthesis of trisubstituted cyclopropanes with **118b-c**.

The intermediate gold(I) carbenes can also be trapped intramolecularly. Thus, cycloheptatriene derivative **118k**, prepared from tropylium tetrafluoroborate in 71% yield, reacted to form exclusively **120af**²²¹ with an *exo* selectivity in 97% yield (Scheme 3.11).

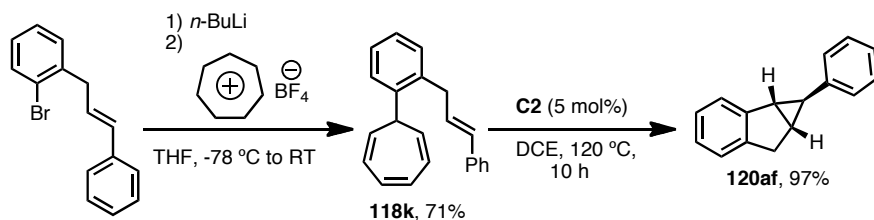

Scheme 3.11. Intramolecular trapping of free benzylden gold(I) carbene generated from **118k**.

Accordingly to the proposed mechanism free benzylden gold(I) carbenes should be formed along with a molecule of benzene. We observed formation of benzene by ¹H NMR by heating cycloheptatriene **118e** in tetrachloroethane-*d*₂ at 70-80 °C with complex **C2** (5 mol%) (Scheme 3.12).

221 Lamberts, J. J. M.; Laarhoven, W. H. *J. Am. Chem. Soc.* **1984**, *106*, 1736-1739.

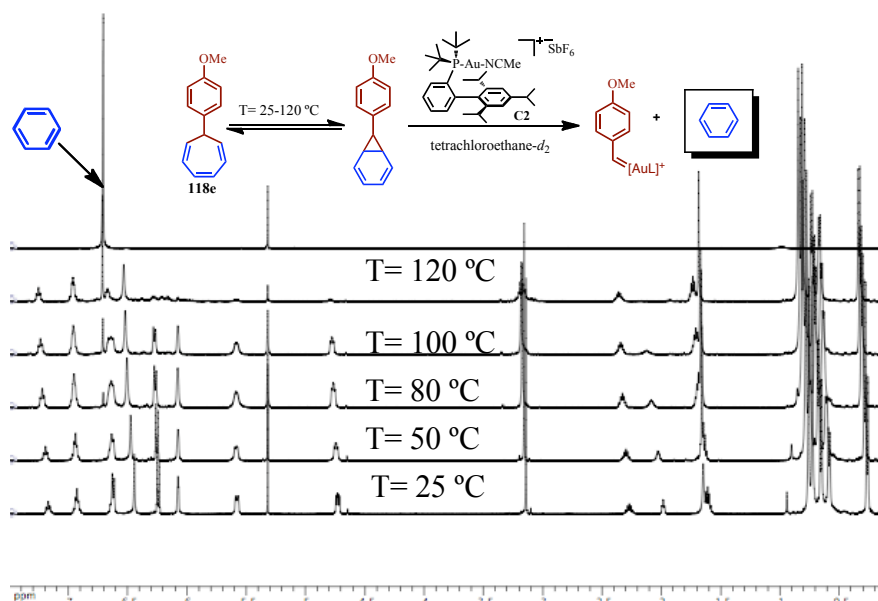

Scheme 3.12. ^1H NMR ($\text{TCE-}d_2$) study of variable temperatures for gold(I) promoted retro-cyclopropanation which confirms the formation of benzene.

On the other hand, when the reaction of **118e** was carried out in 1,2-dichloroethane at 120 °C for 3 h with Ph_2SO (6 equiv), *p*-methoxybenzaldehyde was obtained in 34% yield using catalyst **C5** (5 mol%) by result of the oxidation of the gold(I) carbene formed in the retrocyclopropanation (Scheme 3.13).¹⁰⁵

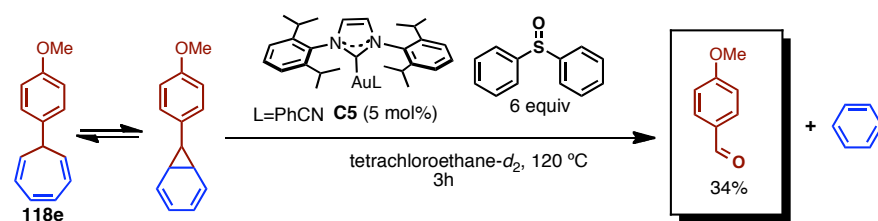

Scheme 3.14. Oxidation of the carbene generated from **118e**.

Few of the carbenes formed in this cyclopropanation reaction can be prepared by using the corresponding 1,1'-diiodo benzyl derivatives under Simmon-Smith conditions (Scheme 3.14).

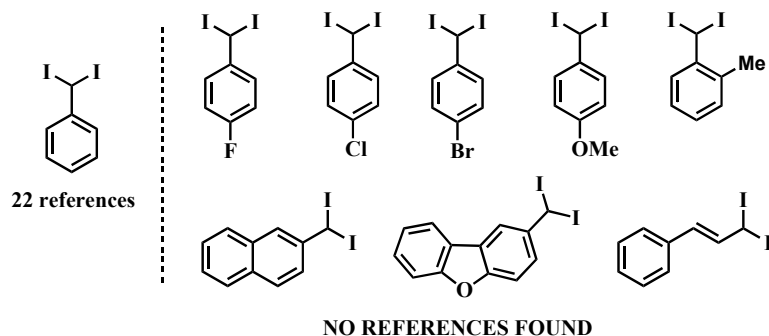

Scheme 3.14. Precursors of arylcarbenoids for the Simmon-Smith reaction.

In the reaction of derivatives **118j**, and **118l** instead of retro-cyclopropanation reaction we found a new annulation process leading to polycyclic compounds (Scheme 3.15).

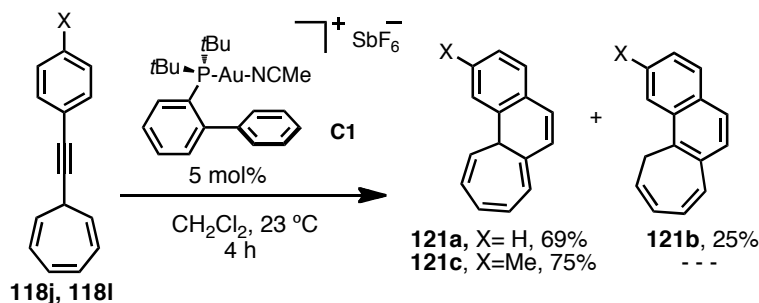

Scheme 3.15. Gold(I)-catalyzed annulation of alkynyl cycloheptatrienes **118j-118l**.

The proposed mechanism for the formation of **121a-b** begins with the coordination of gold(I) to the triple bond, followed by a [1,2]-hydride shift of **121-1** with formation of **121-2**, which after bond rotation would form **121-3**. A 10 π -electrocyclization reaction would furnish **121-4** which upon aromatization would produce **121-5**. An eventual protodeauration reaction would produce the desired compounds **121a** and **121c**. Sequential sigmatropic [1,5]-hydrogen shift would form **121-6** and finally **121b** (Scheme 3.16).

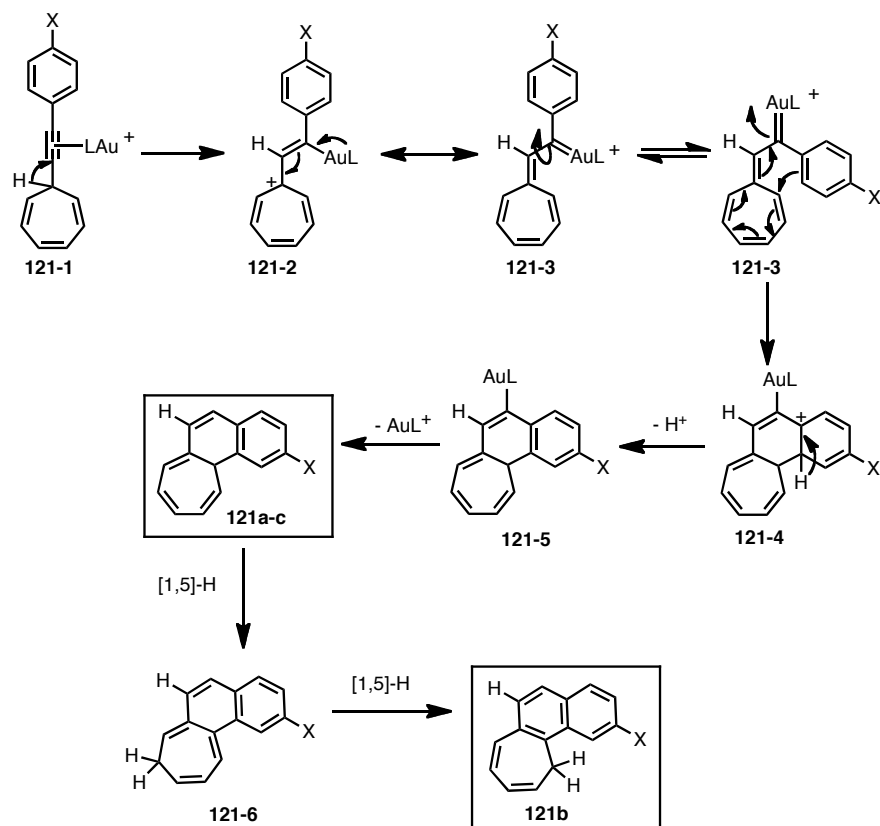

Scheme 3.18. Proposed mechanism for the formation of **120a-b** and **121c**.

When we tried the same reaction with the corresponding alkynyl ferrocene derivative **122**, a skeletal rearrangement of cycloheptatriene took place to yield the known compound **123** (Scheme 3.19).

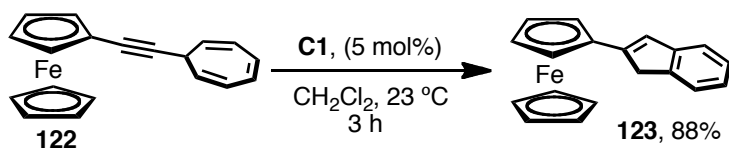

Scheme 3.19. Gold(I)-catalyzed skeletal rearrangement of **122**.

The identity of **123** was confirmed by comparison with the reported spectroscopic data.²²² A new annulation process is under current investigation.

The mechanism of this reaction involves coordination of AuL^+ to norcaradiene **122-1** to form **122-2**, which evolves by cyclopropane opening to give allenyl intermediate **122-3**. Isomerization of **122-4** to propargyl derivative **122-6** via **122-5** would be followed by an intramolecular attack of the electron rich cyclopentadienyl ring to form intermediate **122-7**²²³ which generates **122-8**. Nazarov cyclization of **122-9** forms **122-10**, which undergoes aromatization and protodeauration to form indene **123**.

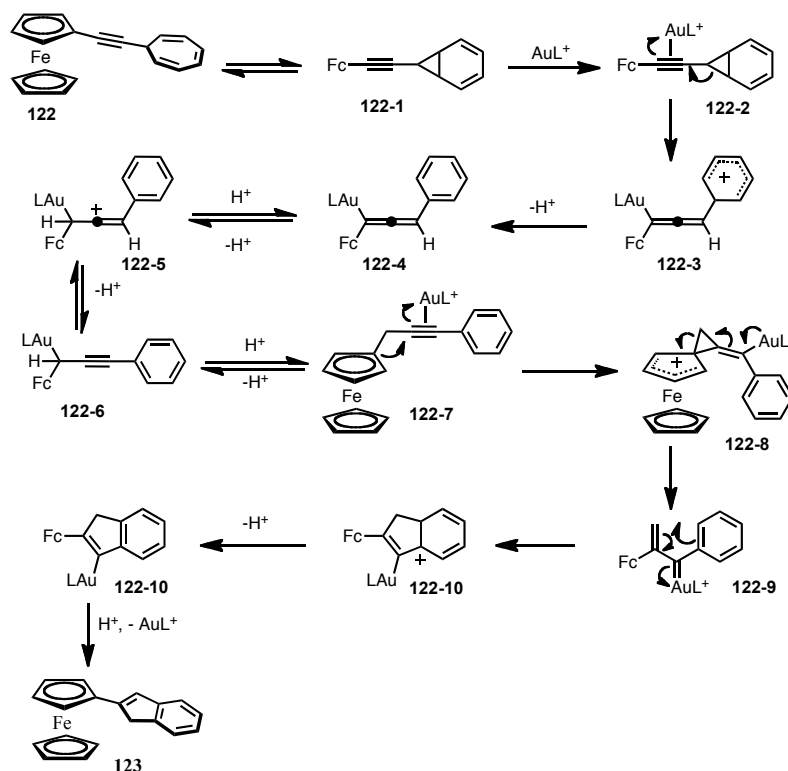

Scheme 3.20. Proposed mechanism for the formation of **123**.

222 Santi, S.; Orian, L.; Duarte, C.; Bisello, A.; Benetollo, F.; Crociani, L.; Ganis, P.; Ceccon, A. *Chem. Eur. J.* **2007**, *13*, 1955-1968.

223 Sanz, R.; Miguel, D.; Gohain, D.; García-García, P.; Fernández-Rodríguez, M. A.; González-Pérez, A.; Nieto-Faza, O.; de Lera, A. R.; Rodríguez, F. *Chem. Eur. J.* **2010**, *16*, 9818-9828.

Conclusions

- Electrophilic Au(I) complexes promoted the retro-Buchner reaction of 7-aryl and vinyl 1,3,5-cycloheptatrienes to generate substituted gold(I) carbenes under catalytic conditions. This is the first report of the metal-promoted retro-Buchner reaction.²²⁴

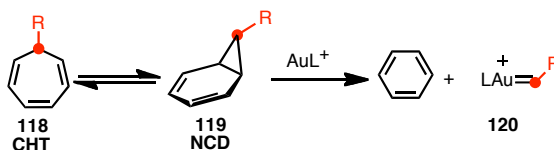

- These carbenes can be trapped by electron-rich as well as electron-poor alkenes in a new cyclopropanation reaction. This reaction is a safer alternative to the use of explosive diazo compounds as cyclopropanating reagents.

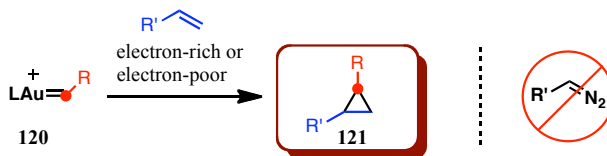

224 Solorio-Alvarado, C. R.; Wang, Y.; Echavarren, A. *J. Am. Chem. Soc.* **2011**, *113*, 11952-11955.

Experimental section

General methods.

All reactions were carried out under N₂ in solvents dried using a Solvent Purification System (SPS). Thin layer chromatography was carried out using TLC aluminum sheets with 0.2 mm of silica gel (Merck Gf234). Chromatographic purifications were carried out using flash grade silica gel (SDS Chromatogel 60 ACC, 40-60 μm). NMR spectra were recorded at 23 °C on a Bruker Avance 400 Ultrashield and Bruker Avance 500 Ultrashield apparatus. Mass spectra were recorded on a Waster LCT Premier Spectrometer (ESI and APCI) or on an Autoflex Broker Daltonics (MALDI and LDI). Melting points were determined using a Büchi melting point apparatus.

Gold complexes (acetonitrile)[(2-biphenyl)di-*tert*-butylphosphine]gold(I) hexafluoroantimonate (**C1**),¹ as well as (acetonitrile)[di-*tert*-butyl(2',4',6'-triisopropyl-[1,1'-biphenyl]-2-yl)phosphine]gold(I) hexafluoroantimonate (**C2**)² were synthesized according to the literature procedures.

Commercial Chemicals

Cyclohepta-1,3,5-triene, phenyllithium, 1-iodo-2-methylbenzene, 1-bromo-4-chlorobenzene, 1-bromo-4-methoxybenzene, 1,4-dibromobenzene, 1-bromo-4-fluorobenzene, *n*-butyllithium, *trans*-stilbene, 1-methoxy-4-vinylbenzene, 1-(trifluoromethyl)-4-vinylbenzene, 1-chloro-4-vinylbenzene, 1-nitro-3-vinylbenzene, 1-(*tert*-butyl)-4-vinylbenzene, 1-methyl-4-vinylbenzene, 1-methyl-3-vinylbenzene, 1-methyl-2-vinylbenzene, (*E*)-prop-1-en-1-ylbenzene, 1-allyl-4-methylbenzene, phenylacetylene, 4-tolylacetylene, ethynylferrocene, (1*E*,3*E*)-1,4-diphenylbuta-1,3-diene, 1-bromo-2-(bromomethyl)benzene, and potassium 2-phenylethenyltrifluoroborate were used as received without any purification.

General Procedure A.

Tropylium tetrafluoroborate³ was synthesized according to the described procedure.

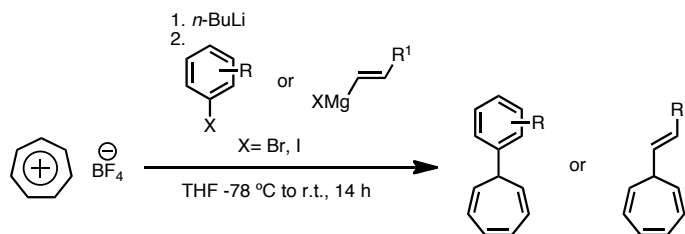

7-Arylcycloheptatriene derivatives 118a-h. The corresponding aryl halide (1.2 equiv) was dissolved in dry THF (0.5 M) and the solution was cooled to -78 °C. Then *n*-BuLi (1.32 equiv) was added dropwise and a red or yellow color was observed. The mixture was stirred for 40 min at the indicated temperature, and then tropylium tetrafluoroborate (1.0 equiv) was added in one portion. The cooling bath was removed and the reaction was stirred at room temperature for 14 h. The reaction was quenched by addition of sat. NH₄Cl solution. The aqueous phase was extracted with EtOAc, the combined organic extracts were dried over MgSO₄, and the solvent was evaporated. The crude reaction mixture was purified by flash chromatography to yield the pure arylcycloheptatrienes.

7-Vinylicycloheptatriene derivatives 120i. Magnesium turnings (2.0 equiv) covered with dry THF (0.3 M) were activated with two drops of 1,2-dibromoethane. A solution of vinyl halide (1.0 equiv) in dry THF was added at room temperature. The mixture was stirred for 10 min after complete addition and heated to 70 °C for 1 h. Then tropylium tetrafluoroborate (1.0 equiv) was added in one portion and the heating was stopped. The reaction was stirred at room temperature for 14 h and quenched by addition of sat. NH₄Cl solution. The aqueous phase was extracted with EtOAc, the combined organic extracts were dried over MgSO₄, and the solvent was evaporated. The crude reaction mixture was purified by flash chromatography to yield the pure vinylicycloheptatriene.

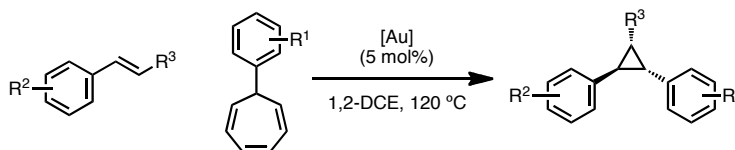
General Procedure B.

An oven-dried sealable Schlenk tube possessing a Teflon screw valve was charged with aryl- or vinylcycloheptatriene (1.0 equiv), olefin (1.5-2.0 equiv) and corresponding gold(I) catalyst (5%). 1,2-dichloroethane (0.5 M) was added via syringe, and the Schlenk tube was sealed. The reaction mixture was heated to 120 °C until the aryl or vinylcycloheptatriene had been completely consumed (15-19 h). The reaction mixture was then allowed to cool at room temperature, filtered through a thin pad of Celite and the eluent was concentrated under reduced pressure. The crude material so obtained was purified via flash chromatography on silica gel to yield pure cyclopropanes. *(These reactions are carried out in a sealed tube at a temperature higher than the boiling point of 1,2-dichloroethane. For larger scale reactions, the appropriate safety precautions should be undertaken).*

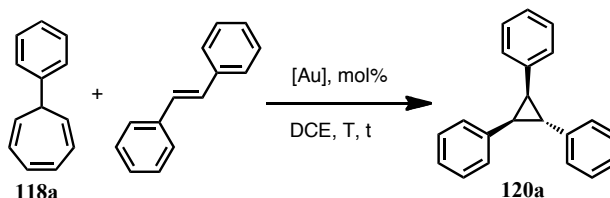
Table 1. Cyclopropanation with 7-Phenylcycloheptatriene **118a**.

Entry	[Au]	T (°C)	T (h)	Yield (%)
1	C1 (5)	r.t.	24	- ^a
2	C2 (5)	r.t.	24	- ^a
3	C3 (5)	r.t.	24	- ^a
4	C4 (5)	r.t.	24	- ^a
5	C5 (5)	r.t.	24	- ^a

6	C6 (5)	r.t.	24	- ^a
7	C7 (5)	r.t.	12	- ^a
8	C8 (5)	r.t.	12	- ^a
9	C9 (5)	r.t.	12	- ^a
10	C9 (5)	80	10	- ^a
11	C1 (5)	80	8	26
12	C2 (5)	80	8	49
13	C3 (5)	80	8	5 ^b
14	C4 (5)	80	10	- ^a
15	C5 (5)	80	8	43
16	C6 (5)	120	8	Au ↓
17	C6(5)	80	8	Au ↓
18	C7 (5)	80	10	Au ↓
19	C9 (5)	80	8	Au ↓
20	C1 (10)	100	5	33
21	C1 (5)	100	5	31
22	C2 (10)	100	5	75
23	C2 (5)	100	5	73
24	C3 (10)	100	5	10
25	C3 (5)	100	5	7
26	C5 (5)	100	5	61
27	C5(10)	100	5	64
28	C2 (5)	120	1.75	78
29	C2 (5)	120	2.25	84^c
30	C5 (5)	120	1.75	70

All the reactions were carried out in 0.3 mmol scale of the alkene and 0.5 M. (a)

No reaction. (b) Determined by NMR. (c) 3 equiv of the cycloheptatriene were used.

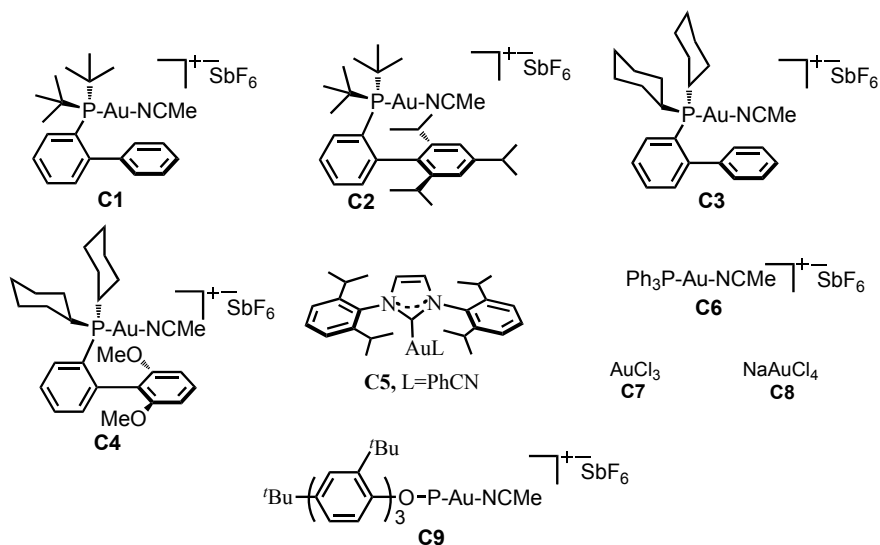

Cycloheptatrienes 118a-118l.

7-Phenylcyclohepta-1,3,5-triene (118a).⁴

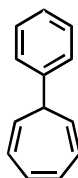

This compound was prepared as an amber oil in 67% yield according to the general procedure **C1**, starting from phenyllithium and tropylium tetrafluoroborate.

¹H NMR (400 MHz, CDCl₃) δ 7.39-7.34 (m, 4H), 7.30-7.27 (m, 1H), 6.76 (dd, *J* = 3.5, 2.8 Hz, 2H), 6.27 (dddd, *J* = 8.7, 3.8, 2.6, 1.5 Hz, 2H), 5.44 (dd, *J* = 8.7, 5.6 Hz, 2H), 2.74 (tt, *J* = 5.6, 1.4 Hz, 1H).

¹³C NMR (100 MHz, CDCl₃) δ 144.1, 131.1, 128.9, 127.8, 127.4, 126.5, 124.6, 45.5. The spectroscopic data match with those reported in the literature.

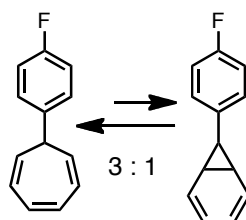
7-(4-Fluorophenyl)cyclohepta-1,3,5-triene (118b).

This 3:1 cycloheptatriene / norcaradiene mixture was prepared as a yellow dark oil in 53% yield according to the general procedure **C1**, using 1-bromo-4-fluorobenzene (2 equiv) and of tropylium tetrafluoroborate (1 equiv). Signals for cycloheptatriene tautomer.

^1H NMR (400 MHz, CDCl_3) δ 7.32 (dd, $J = 8.5, 5.4$ Hz, 2H), 7.05 (t, $J = 8.7$ Hz, 2H), 6.88-6.63 (m, 2H), 6.43-6.11 (m, 2H), 5.38 (dd, $J = 8.8, 5.6$ Hz, 2H), 2.72 (t, $J = 5.6$ Hz, 1H).

^{13}C NMR (100 MHz, CDCl_3) δ 161.1 (d, $J = 243$ Hz), 139.7 (d, $J = 3$ Hz), 131.2, 129.1, 126.3, 124.8, 115.4 (d, $J = 21$ Hz), 44.53.

Selected signals for norcaradiene tautomer. ^1H NMR (400 MHz, CDCl_3) δ 7.09-7.01 (m, 2H), 6.80-6.75 (m, 2H), 6.33-6.27 (m, 2H), 5.44-5.40 (m, 2H), 1.82 (t, $J = 4.8$ Hz, 1H), 1.29-1.21 (m, 1H), 1.84 (t, $J = 7.2$ Hz, 1H).

^{13}C NMR (100 MHz, CDCl_3) δ 140.5 (d, $J = 3$ Hz), 130.0, 129.2, 125.7, 113.38 (d, $J = 21$ Hz), δ 27.3, 23.4, 14.2. HRMS-EI calcd for $\text{C}_{13}\text{H}_{11}\text{F}$ (M) $^+$: 186.0845; found: 186.0852.

7-(4-Chlorophenyl)cyclohepta-1,3,5-triene (118c).

This compound was prepared as a yellow oil in 70% yield according to the general procedure **C1**, starting from 1-bromo-4-chlorobenzene and tropylium tetrafluoroborate.

^1H NMR (400 MHz, CDCl_3) δ 7.48-7.25 (m, 4H), 6.74 (dd, $J = 3.5, 2.8$ Hz, 2H), 6.28-6.25 (m, 2H), 5.37 (dd, $J = 8.8, 5.6$ Hz, 2H), 2.73 (t, $J = 5.6$ Hz, 1H).

^{13}C NMR (100 MHz, CDCl_3) δ 142.2, 132.3, 131.0, 129.0, 128.9, 128.7, 128.2, 125.6, 124.7, 44.6. HRMS-EI calcd for $\text{C}_{13}\text{H}_{11}\text{Cl}$ (M) $^+$: 202.0549; found: 202.0553.

7-(4-Bromophenyl)cyclohepta-1,3,5-triene (**118d**).⁵

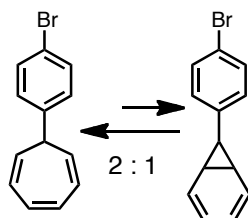

This 2:1 cycloheptatriene / norcaradiene mixture was prepared as a white-colorless semisolid in 58% yield according to the general procedure **C1**, starting from 1,4-dibromobenzene and tropylium tetrafluoroborate.

Signals for cycloheptatriene tautomer: ^1H NMR (400 MHz, CDCl_3) δ 7.49 (d, $J = 8.5$ Hz, 2H), 7.23 (d, $J = 8.4$ Hz, 2H), 6.74 (dd, $J = 3.5, 2.8$ Hz, 2H), 6.27 (m, 2H), 5.37 (dd, $J = 8.8, 5.6$ Hz, 2H), 2.72 (t, $J = 5.6$ Hz, 1H).

^{13}C NMR (100 MHz, CDCl_3) δ 142.8, 131.7, 131.0, 129.3, 125.5, 124.7, 120.3, 44.66.

Selected signals for norcaradiene tautomer: ^1H NMR (400 MHz, CDCl_3) δ 7.56 (d, $J = 8.5$ Hz, 2H), 7.38 (d, $J = 8.4$ Hz, 2H), 5.42 (dd, $J = 8.8, 5.6$ Hz, 2H), 1.64 (m, 1H), 1.40 (m, 1H), 0.94 (m, 1H).

^{13}C NMR (100 MHz, CDCl_3) δ 35.5, 22.6, 14.2. The spectroscopic data match with those reported in the literature.

7-(4-Methoxyphenyl)cyclohepta-1,3,5-triene (118e).

Cycloheptatriene **60e** was prepared as a greenish or yellow oil in 74% yield according to the general procedure **C1**, starting from 1-bromo-4-methoxybenzene and tropylium tetrafluoroborate.

^1H NMR (400 MHz, CDCl_3) δ 7.29 (d, $J = 8.4$ Hz, 2H), 6.92 (d, $J = 8.4$ Hz, 2H), 6.74 (dd, $J = 3.5, 2.8$ Hz, 2H), 6.24 (m, 2H), 5.40 (dd, $J = 8.8, 5.6$ Hz, 2H), 3.82 (s, 3H), 2.67 (t, $J = 5.6$ Hz, 1H).

^{13}C NMR (100 MHz, CDCl_3) δ 158.2, 136.0, 130.9, 128.4, 126.6, 124.2, 114.0, 55.3, 44.5. HRMS-APCI calcd for $\text{C}_{14}\text{H}_{14}\text{O}$ ($M+\text{H}$) $^+$: 199.1123; found: 199.1130.

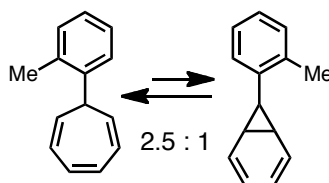
7-(*o*-Tolyl)cyclohepta-1,3,5-triene (118f).

This 2.5:1 cycloheptatriene / norcaradiene mixture was prepared as a yellow oil in 81% yield according to the general procedure **C1**, starting from 2-iodotoluene and tropylium tetrafluoroborate.

Signals for cycloheptatriene tautomer: ^1H NMR (500 MHz, CDCl_3) δ 7.47 (d, $J = 7.6$ Hz, 1H), 7.35-7.24 (m, 1H), 7.23-7.16 (m, 2H), 7.14-7.10 (m, 1H), 6.74 (dd, $J = 3.4, 2.8$ Hz, 2H), 6.44-6.20 (m, 2H), 5.38 (dd, $J = 8.8, 5.5$ Hz, 2H), 2.92 (t, $J = 5.5$ Hz, 1H), 2.22 (s, 3H).

^{13}C NMR (126 MHz, CDCl_3) δ 142.0, 136.3, 131.0, 130.7, 126.8, 126.6, 126.6, 126.4, 124.8, 41.8, 19.7.

Selected signals for norcaradiene tautomer: ^1H NMR (500 MHz, CDCl_3) δ 7.29-7.24 (m, 3H), 7.15-7.06 (m, 2H), 6.71-6.68 (m, 1H), 6.31-6.23 (m, 1H), 5.32-5.27 (m, 1H), 2.30 (s, 3H), 1.58-1.51 (m, 1H), 1.40 (m, 1H), 0.94 (t, $J = 7.0$ Hz, 1H).

^{13}C NMR (126 MHz, CDCl_3) δ 141.3, 136.0, 131.2, 130.3, 129.0, 126.0, 125.9, 125.2, 42.2, 33.2, 32.7, 23.0, 19.5, 14.3. HRMS-APCI calcd for $\text{C}_{14}\text{H}_{14}$ ($M+\text{H}$) $^+$: 183.1174; found: 183.1185.

2-(Cyclohepta-2,4,6-trien-1-yl)naphthalene (118g).

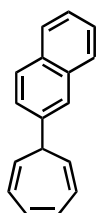

This compound was prepared as a white solid in 63% yield, m.p. 88.5-91 °C according to the general procedure **C1**, starting from 2-bromonaphthalene and tropylium tetrafluoroborate.

^1H NMR (400 MHz, CDCl_3) δ 8.14-7.68 (m, 4H), 7.60-7.40 (m, 3H), 6.93-6.69 (m, 2H), 6.47-6.14 (m, 2H), 5.54 (dd, $J = 8.8, 5.7$ Hz, 2H), 2.92 (t, $J = 5.3$ Hz, 1H).

^{13}C NMR (101 MHz, CDCl_3) δ 141.3, 133.7, 132.6, 131.2, 128.7, 127.9, 127.8, 126.4, 126.3, 126.0, 125.7, 124.8, 45.5. HRMS-APCI calcd for $\text{C}_{17}\text{H}_{15}$ ($M+\text{H}$) $^+$: 219.1174; found: 219.1168.

2-(Cyclohepta-2,4,6-trien-1-yl)dibenzo[*b,d*]furan (118h).

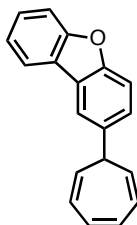

This compound was prepared as a cream solid in 68% yield, m.p. 121-123 °C according to the general procedure **C1**, starting from 2-bromodibenzo[*b,d*]furan⁶ and tropylium tetrafluoroborate. ¹H NMR (500 MHz, CDCl₃) δ 8.02-7.90 (m, 2H), 7.57 (dd, *J* = 8.3, 4.0 Hz, 2H), 7.50-7.43 (m, 2H), 7.34 (td, *J* = 7.6, 0.9 Hz, 1H), 6.78 (dd, *J* = 3.4, 2.9 Hz, 2H), 6.32-6.24 (m, 2H), 5.52 (dd, *J* = 8.8, 5.6 Hz, 2H), 2.91 (t, *J* = 5.6 Hz, 1H).

¹³C NMR (126 MHz, CDCl₃) δ 156.8, 155.3, 138.8, 131.2, 127.3, 127.0, 126.9, 124.6, 124.4, 122.8, 120.8, 119.6, 111.9, 111.9, 45.51. HRMS-APCI calcd for C₁₄H₁₄O (*M*+H)⁺: 259.1123; found: 259.1128.

(*E*)-7-Styrylcyclohepta-1,3,5-triene (118i).

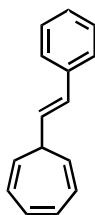

This compound was prepared as a brown oil in 65% yield according to the general procedure **C1**, starting from (*E*)-(2-bromovinyl)benzene⁷ (2 equiv) and tropylium tetrafluoroborate (1 equiv).

¹H NMR (400 MHz, CDCl₃) δ 7.40 (dd, *J* = 7.5, 1.2 Hz, 2H), 7.32 (t, *J* = 7.5 Hz, 2H), 7.24 (t, *J* = 7.4 Hz, 1H), 6.70 (dd, *J* = 3.5, 2.8 Hz, 2H), 6.55 (d, *J* = 15.8 Hz, 1H), 6.50 (d, *J* = 15.8 Hz, 1H), 6.28-6.22 (m, 2H), 5.34 (dd, *J* = 8.8, 5.7 Hz, 2H), 2.48-2.40 (m, 1H).

¹³C NMR (101 MHz, CDCl₃) δ 137.6, 131.2, 131.1, 130.7, 128.7, 127.5, 126.4, 124.8, 124.6, 42.3. HRMS-APCI calcd for C₁₅H₁₄ (*M*)⁺: 194.1096; found: 194.1087.

7-(Phenylethynyl)cyclohepta-1,3,5-triene (118j).

Phenylacetylene (510.2 mg, 5.0 mmol) was dissolved in THF (0.1M). The solution was cooled to $-78\text{ }^{\circ}\text{C}$ before addition of *n*-BuLi (2.6M, 2.1 mL, 5.5 mmol, 1.1 equiv). The mixture was stirred 40 min at this temperature, then solid tropylium tetrafluoroborate (890.3 mg, 5.0 mmol) was added in one portion and stirred additionally 5 h. The cooling bath was removed and the reaction was stopped by addition of sat. NH_4Cl solution. The aqueous phase was extracted with EtOAc, the combined organic extract was dried over MgSO_4 , and the solvent was evaporated. The crude reaction mixture was purified by flash chromatography to yield **118j** (768.2 mg, 80%) as yellow oil.

^1H NMR (500 MHz, CDCl_3) δ 7.46 (dd, $J = 6.5, 3.2$ Hz, 2H), 7.35 – 7.28 (m, 3H), 6.69 (dd, $J = 3.4, 2.9$ Hz, 2H), 6.22 (dddd, $J = 8.6, 3.8, 2.6, 1.4$ Hz, 2H), 5.43 (dd, $J = 8.8, 5.5$ Hz, 2H), 2.73 – 2.69 (m, 1H).

^{13}C NMR (126 MHz, CDCl_3) δ 131.9, 131.2, 128.5, 128.1, 124.9, 123.7, 123.4, 91.3, 80.8, 32.5. HRMS-APCI calcd for $\text{C}_{15}\text{H}_{12}$ (M) $^+$: 193.1017; found: 193.1018.

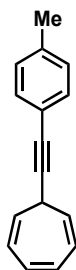
7-(*p*-Tolyethynyl)cyclohepta-1,3,5-triene (118l).

1-Ethynyl-4-methylbenzene (348.2 mg, 3.0 mmol) was dissolved in THF (0.1M). The solution was cooled to $-78\text{ }^{\circ}\text{C}$ before addition of *n*-BuLi (2.6M,

1.27 mL, 3.3 mmol, 1.1 equiv). The mixture was stirred 40 min at this temperature, then solid tropylium tetrafluoroborate (534.2 mg, 3.0 mmol) was added in one portion and stirred additionally 5 h. The cooling bath was removed and the reaction was stopped by addition of sat. NH₄Cl solution. The aqueous phase was extracted with EtOAc, the combined organic extract was dried over MgSO₄, and the solvent was evaporated. The crude reaction mixture was purified by flash chromatography to yield **1181** (515.4 mg, 83%) as brown oil.

¹H NMR (500 MHz, CDCl₃) δ 7.46-7.39 (m, 2H), 7.17 (d, *J* = 8.0 Hz, 2H), 6.78-6.70 (m, 2H), 6.30-6.23 (m, 2H), 5.53-5.45 (m, 2H), 2.75 (t, *J* = 5.5 Hz, 1H), 2.40 (s, 3H).

¹³C NMR (126 MHz, CDCl₃) δ 138.1, 131.8, 131.2, 129.2, 124.9, 123.6, 120.5, 90.5, 80.8, 32.5, 21.6. HRMS-APCI calcd for C₁₆H₁₅ (*M*)⁺: 243.1174; found: 243.1177.

Cyclopropanes **120a-120ae**.

1,2,3-Triphenylcyclopropane (**120a**).⁸

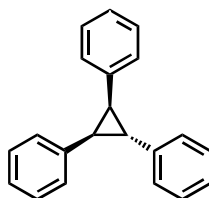

This compound was prepared as single stereoisomer, using gold catalyst **C2** according to the general procedure **B**, starting from *trans*-stilbene and 7-phenylcyclohepta-1,3,5-triene **118a**. Colorless oil (84%).

¹H NMR (400 MHz, CDCl₃) δ 7.36-7.31 (m, 4H), 7.24-7.21 (m, 1H), 7.16-7.08 (m, 6H), 7.02-6.99 (m, 4H), 2.86-2.81 (m, 3H).

¹³C NMR (100 MHz, CDCl₃) δ 142.2, 137.9, 129.2, 128.7, 128.0, 126.7, 126.3, 126.1, 34.7, 30.9. The spectroscopic data match with those reported in the literature.

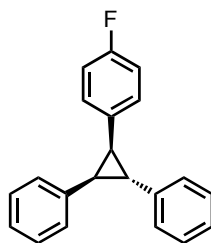
((1*R*^{*}, 2*R*^{*})-3-(4-Fluorophenyl)cyclopropane-1,2-diyl)dibenzene (120b).

This compound was prepared as single stereoisomer, using gold catalyst **C2** according to the general procedure **B**, starting from *trans*-stilbene and 7-(4-fluorophenyl)cyclohepta-1,3,5-triene **118b**. Colorless oil (61%).

¹H NMR (400 MHz, CDCl₃) δ 7.38-7.29 (m, 4H), 7.25-7.21 (m, 1H), 7.18-7.08 (m, 3H), 7.0-6.94 (m, 4H), 6.83 (t, $J = 8.6$ Hz, 2H), 2.79 (bs, 3H).

¹³C NMR (100 MHz, CDCl₃) δ 161.5 (d, $J = 242$ Hz), 141.9, 137.6, 133.5, 130.6 (d, $J = 8$ Hz), 129.0, 128.8, 128.1, 126.6, 126.4, 126.2, 114.9 (d, $J = 21$ Hz), 34.5, 33.9, 30.9. MALDI calcd for C₂₁H₁₇F ($M+Ag$)⁺: 395.0360; found: 395.0331.

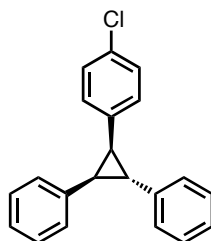
((1*R*^{*}, 2*R*^{*})-3-(4-chlorophenyl)cyclopropane-1,2-diyl)dibenzene (120c).

This compound was prepared as single stereoisomer, using gold catalyst **C2** according to the general procedure **B**, starting from *trans*-stilbene and 7-(4-chlorophenyl)cyclohepta-1,3,5-triene **118c**. Colorless oil (91%).

¹H NMR (400 MHz, CDCl₃) δ 7.37-7.28 (m, 4H), 7.26-7.21 (m, 1H), 7.19-7.07 (m, 5H), 7.00 (d, $J = 8.4$ Hz, 2H), 6.95 (d, $J = 8.4$ Hz, 2H), 2.87-2.73 (m, 3H).

^{13}C NMR (100 MHz, CDCl_3) δ 141.7, 137.3, 136.5, 131.9, 130.4, 129.2, 128.8, 128.2(x2), 126.6, 126.5, 126.4, 34.7, 33.9, 30.9. MALDI calcd for $\text{C}_{21}\text{H}_{17}\text{Cl}$ ($M+\text{Ag}$) $^+$: 411.0064; found: 411.0111.

((1*R*^{*},2*R*^{*})-3-(4-Bromophenyl)cyclopropane-60,2-diyl)dibenzene (120d).

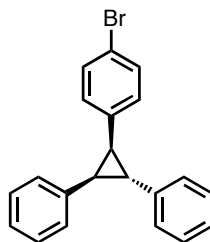

This compound was prepared as single stereoisomer, using gold catalyst **C2** according to the general procedure **B**, starting from *trans*-stilbene and 7-(4-bromophenyl)cyclohepta-1,3,5-triene **118d**. Brown oil (82%).

^1H NMR (400 MHz, CDCl_3) δ 7.37-7.29 (m, 4H), 7.26-7.22 (m, 3H), 7.19-7.10 (m, 3H), 7.00 (d, $J = 7.0$ Hz, 2H), 6.86 (d, $J = 7.0$ Hz, 2H), 2.85 (dd, $J = 9.0, 6.0$ Hz, 1H), 2.80 (t, $J = 6.5$ Hz, 1H), 2.74 (dd, 9.0, 6.0 Hz, 1H).

^{13}C NMR (100 MHz, CDCl_3) δ 141.7, 137.3, 137.1, 131.1, 130.7, 129.2, 128.8, 128.2, 126.6, 126.5, 126.4, 120.0, 34.7, 34.0, 30.9. HRMS-APCI calcd for $\text{C}_{21}\text{H}_{17}\text{Br}$ (M) $^+$: 348.0514; found: 348.0536.

((1*R*^{*},2*R*^{*})-3-(4-Methoxyphenyl)cyclopropane-1,2-diyl)dibenzene (120e).

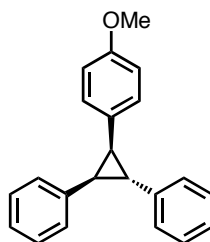

This compound was prepared as single stereoisomer, using gold catalyst **C2** according to the general procedure **B**, starting from *trans*-stilbene and 7-(4-methoxyphenyl)cyclohepta-1,3,5-triene **118e**. Yellow oil (67%).

^1H NMR (400 MHz, CDCl_3) δ 7.37-7.29 (m, 4H), 7.25-7.20 (m, 1H), 7.16-7.07 (m, 3H), 6.99 (d, $J = 7.0$ Hz, 2H), 6.94 (d, $J = 8.5$ Hz, 2H), 6.69 (d, $J = 8.5$ Hz, 2H), 3.73 (s, 3H), 2.82-2.73 (m, 3H).

^{13}C NMR (100 MHz, CDCl_3) δ 158.1, 142.2, 138.1, 130.3, 129.8, 129.0, 128.7, 128.0, 126.6, 126.2, 126.0, 113.6, 55.4, 34.5, 34.1, 31.0. HRMS-APCI calcd for $\text{C}_{22}\text{H}_{20}\text{O}$ (M) $^+$: 300.1514; found: 300.1521.

2-((2*R*^{*},3*R*^{*})-2,3-Diphenylcyclopropyl)naphthalene (**120f**).

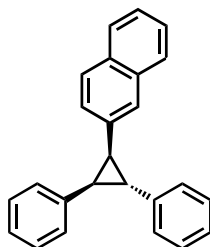

This compound was prepared as single stereoisomer, using gold catalyst **C2** according to the general procedure **B**, starting from *trans*-stilbene (1 equiv) and 2-(cyclohepta-2,4,6-trien-1-yl)naphthalene **118g** (3 equiv). Colorless oil (44%, 93% brsm).

^1H NMR (400 MHz, CDCl_3) δ 7.76 (d, $J = 8.6$ Hz, 1H), 7.71 (d, $J = 7.3$ Hz, 1H), 7.63 (d, $J = 8.5$ Hz, 1H), 7.59 (s, 1H), 7.46-7.37 (m, 6H), 7.33-7.29 (m, 1H), 7.20-7.04 (m, 6H), 3.02 (d, $J = 7.7$ Hz, 2H), 2.94 (t, $J = 7.8$ Hz, 1H).

^{13}C NMR (101 MHz, CDCl_3) δ 142.1, 137.8, 135.6, 133.4, 132.2, 129.1, 128.7, 128.1, 127.7, 127.6, 127.5, 126.6, 126.3, 126.2, 125.9, 125.4, 34.9, 34.8, 31.1.

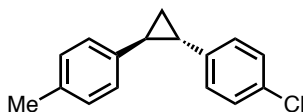
1-Chloro-4-((1*R,2*R**)-2-(*p*-tolyl)cyclopropyl)benzene (120g).**

This compound was prepared using gold catalyst **C1** according to the general procedure **B**, starting from 1-methyl-4-vinylbenzene and 7-(4-chlorophenyl)cyclohepta-1,3,5-triene **118c**. Colorless oil (70%, 9:1 dr).

Signals for the *trans* stereoisomer: ^1H NMR (400 MHz, CDCl_3) δ 7.06 (d, $J = 8.5$ Hz, 2H), 6.92 (d, $J = 8.0$ Hz, 2H), 6.89-6.78 (m, 4H), 2.45 (dd, $J = 8.7, 6.5$ Hz, 1H), 2.39 (td, $J = 8.9, 6.4$ Hz, 1H), 2.24 (s, 3H), 1.45 (td, $J = 8.8, 5.6$ Hz, 1H), 1.33-1.25 (m, 1H).

^{13}C NMR (100 MHz, CDCl_3) δ 137.5, 135.5, 134.9, 131.4, 130.3, 129.1, 128.8, 128.0, 24.4, 23.7, 21.2, 11.7. HRMS-APCI calcd for $\text{C}_{16}\text{H}_{15}\text{Cl}$ (M) $^+$: 242.0862; found: 242.0870.

Selected signals for *cis* stereoisomer: ^1H NMR (400 MHz, CDCl_3) δ 7.06 (d, $J = 8.5$ Hz, 2H), 7.11 (d, $J = 8.0$ Hz, 2H), 2.33 (s, 3H), 2.10 (t, $J = 7.4$ Hz, 2H), 1.37 (m, 1H). ^{13}C NMR (100 MHz, CDCl_3) δ 135.7, 129.3, 128.6, 127.3, 125.9.

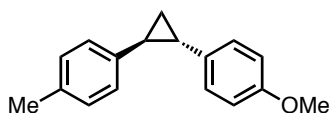
1-Methoxy-4-((1*R,2*R**)-2-(*p*-tolyl)cyclopropyl)benzene (120h).**

This compound was prepared using gold catalyst **C1** according to the general procedure **B**, starting from 1-methyl-4-vinylbenzene and 7-(4-methoxyphenyl)cyclohepta-1,3,5-triene **118e**. Colorless oil (77%, 1.3:1 dr).

^1H NMR (400 MHz, CDCl_3) δ 7.13-7.01 (m, 4H *trans* + 2H *cis*), 6.93-6.78 (m, 4H *trans* + 4H *cis*), 6.66 (d, $J = 8.7$ Hz, 2H *cis*), 3.80 (s, 3H *trans*), 3.72 (s, 3H *cis*), 2.42-2.35 (m, 2H *cis*), 2.33 (s, 3H *trans*), 2.23 (s, 3H *cis*), 2.12-2.04 (m, 2H *trans*), 1.42 (dt, $J = 8.7, 4.3$ Hz, 1H *cis*), 1.36 (dd, $J = 7.7, 6.9$ Hz, 2H *trans*), 1.25 (dd, $J = 12.0, 5.8$ Hz, 1H *cis*).

^{13}C NMR (100 MHz, CDCl_3) δ 158.02 (*trans*), 157.74 (*cis*), 139.86 (*trans*), 135.72 (*cis*), 135.36 (*trans*), 135.02 (*cis*), 134.89 (*trans*), 130.73 (*cis*), 130.27, 129.26 (*trans*), 128.87 (*cis*), 128.59 (*cis*), 127.09 (*trans*), 125.86 (*trans*), 114.06 (*trans*), 113.36 (*cis*), 55.54 (*trans*), 55.31 (*cis*), 27.42 (*cis*), 27.33 (*trans*), 23.78 (*cis*), 23.75 (*trans*), 21.18 (*cis* + *trans*), 17.80 (*trans*), 11.71 (*cis*). HRMS-APCI calcd for $\text{C}_{17}\text{H}_{18}\text{O}$ ($M+\text{H}$) $^+$: 239.1436; found: 239.1437.

1-Bromo-4-((1*R**,2*R**)-2-(*p*-tolyl)cyclopropyl)benzene (**120i**).

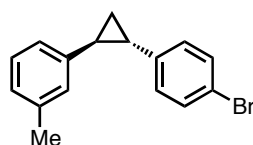

This compound was prepared using gold catalyst **C1** according to the general procedure **B**, starting from 1-methyl-3-vinylbenzene and 7-(4-bromophenyl)cyclohepta-1,3,5-triene **118d**. Colorless oil (81%, 9:1 dr).

Signals for the *trans* stereoisomer: ^1H NMR (400 MHz, CDCl_3) δ 7.20 (d, $J = 8.4$ Hz, 2H), 6.98 (t, $J = 7.6$ Hz, 1H), 6.87 (dd, $J = 7.5, 0.5$ Hz, 1H), 6.79 (dd, $J = 4.3, 3.8$ Hz, 3H), 6.68 (dd, $J = 7.6, 0.6$ Hz, 1H), 2.46 (td, $J = 8.9, 6.5$ Hz, 1H), 2.38 (td, $J = 8.9, 6.2$ Hz, 1H), 2.20 (s, 3H), 1.45 (td, $J = 8.6, 5.4$ Hz, 1H), 1.31 (dd, $J = 11.8, 6.3$ Hz, 1H).

^{13}C NMR (100 MHz, CDCl_3) δ 137.9, 137.9, 137.5, 130.9, 130.8, 130.1, 127.9, 126.8, 126.1, 119.5, 24.6, 23.9, 21.5, 11.7. HRMS-APCI calcd for $\text{C}_{16}\text{H}_{15}\text{Br}$ (M) $^+$: 286.0357; found: 286.0369.

Selected signals for the *cis* stereoisomer: ^1H NMR (400 MHz, CDCl_3) δ 7.39 (d, $J = 8.4$ Hz, 2H), 2.33 (s, 3H), 1.41-1.35 (m, 2H). ^{13}C NMR (100 MHz, CDCl_3) δ 131.6, 128.6, 127.7, 122.9, 28.3, 27.6, 21.6, 18.3.

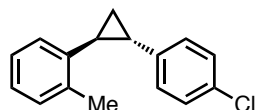
1-((1*R,2*R**)-2-(4-Chlorophenyl)cyclopropyl)-2-methylbenzene (120j).**⁹

This compound was prepared using gold catalyst **C1** according to the general procedure **B**, starting from 1-methyl-2-vinylbenzene and 7-(4-chlorophenyl)cyclohepta-1,3,5-triene **118c**. Colorless oil (80%, 10:1 dr).

Signals for the *trans* stereoisomer: ¹H NMR δ 7.17-7.02 (m, 4H), 6.96 (d, *J* = 8.5 Hz, 2H), 6.71 (d, *J* = 8.5 Hz, 2H), 2.47-2.40 (m, 2H), 2.12 (s, 3H), 1.51 (td, *J* = 8.6, 5.4 Hz, 1H), 1.39 (dd, *J* = 12.0, 6.3 Hz, 1H).

¹³C NMR (100 MHz, CDCl₃) δ 138.9, 137.9, 135.6, 131.1, 129.7, 129.2, 128.7, 127.7, 126.6, 125.56, 24.9, 23.0, 19.8, 11.9. The spectroscopic data match with those reported in the literature.

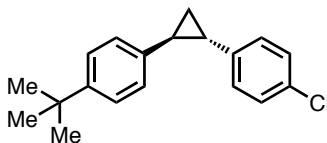
1-(*tert*-Butyl)-4-((1*R,2*R**)-2-(4-chlorophenyl)cyclopropyl)benzene (120k).**

This compound was prepared using gold catalyst **C1** according to the general procedure **B**, starting from 1-(*tert*-butyl)-4-vinylbenzene and 7-(4-chlorophenyl)cyclohepta-1,3,5-triene **118c**. Colorless oil (66%, 6:1 dr).

Signals for the *trans* stereoisomer: ¹H NMR (400 MHz, CDCl₃) δ 7.32 (d, *J* = 8.3 Hz, 2H), 7.23 (d, *J* = 8.5 Hz, 2H), 2.14-2.07 (m, 1H), 1.31 (s, 9H).

¹³C NMR (100 MHz, CDCl₃) δ 149.1 (*cis*), 148.8 (*trans*), 141.4 (*cis*), 139.3 (*cis*), 137.5 (*trans*), 135.0 (*trans*), 131.5 (*cis*), 131.4 (*trans*), 130.4 (*trans*), 128.8 (*trans*), 128.6 (*cis*), 127.9 (*trans*), 127.3 (*cis*), 125.6 (*cis*), 125.56 (*cis*), 124.9 (*trans*), 34.5 (*cis*), 31.8 (*cis*), 31.6 (*trans*), 31.5 (*trans*), 27.9 (*cis*), 27.4 (*cis*), 24.3 (*trans*), 23.8 (*trans*), 18.3 (*cis*), 12.1 (*trans*). HRMS-APCI calcd for C₁₉H₂₁Cl (*M*)⁺: 284.1332; found: 284.1339.

Selected signals the *cis* stereoisomer: ^1H NMR (400 MHz, CDCl_3) δ 7.13 (d, $J = 8.3$ Hz, 2H), 7.05 (d, $J = 8.5$ Hz, 2H), 6.85 (dd, $J = 8.5, 2.6$ Hz, 4H), 2.45 (td, $J = 8.9, 6.6$ Hz, 1H), 2.39 (td, $J = 8.8, 6.4$ Hz, 1H), 1.46 (td, $J = 8.5, 5.5$, 1H), 1.29-1.25 (m, 1H), 1.24 (s, 9H).

1-(*tert*-Butyl)-4-2-(4-methoxyphenyl)cyclopropyl)benzene (120l).

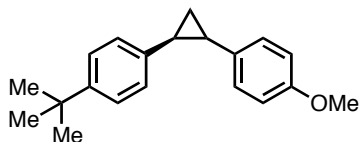

This compound was prepared using gold catalyst **C1** according to the general procedure **B**, starting from 1-(*tert*-butyl)-4-vinylbenzene and 7-(4-methoxyphenyl)cyclohepta-1,3,5-triene **118e**. Colorless oil (61%, 1:1 dr).

^1H NMR (400 MHz, CDCl_3) δ 7.35 (d, $J = 8.3$ Hz, 2H *cis*), 7.14 (d, $J = 8.4$ Hz, 2H *cis*), 7.10 (dd, $J = 8.5, 3.1$ Hz, 4H *cis*), 6.92 (d, $J = 8.6$ Hz, 2H *trans*), 6.86 (dd, $J = 8.5, 3.1$ Hz, 4H *trans*), 6.69 (d, $J = 8.7$ Hz, 2H *trans*), 3.81 (s, 3H *trans*), 3.74 (s, 3H *cis*), 2.44-2.38 (m, 2H *cis*), 2.18-2.12 (m, 1H *trans*), 2.12-2.06 (m, 1H *trans*), 1.47-1.43 (m, 1H *trans*), 1.39 (ddd, $J = 8.5, 6.0, 3.3$ Hz, 1H *cis* + 1H *trans*), 1.35 (s, 9H *cis*), 1.28-1.21 (m, 1H *cis*), 1.26 (s, 9H *trans*).

^{13}C NMR (100 MHz, CDCl_3) δ 158.0 (*cis*), 157.7 (*trans*), 148.7 (*cis*), 148.4 (*trans*), 139.9 (*cis*), 135.8 (*trans*), 134.9 (*cis*), 130.8 (*trans*), 130.3 (*cis*), 128.60 (*trans*), 127.1 (*cis*), 125.6 (*trans*), 125.5 (*trans*), 124.7 (*cis*), 114.0 (*cis*), 113.3 (*trans*), 55.5 (*cis*), 55.3 (*trans*), 34.6 (*cis*), 34.4 (*trans*), 31.6 (*cis*), 31.5 (*trans*), 27.3 (*cis* + *trans*), 23.8 (*cis*), 23.7 (*trans*), 17.9 (*cis*), 12.1 (*trans*). HRMS-APCI calcd for $\text{C}_{20}\text{H}_{24}\text{O}$ ($M+H$) $^+$: 281.1905; found: 281.1903.

(1*R,2*R**)-1,2-bis(4-Methoxyphenyl)cyclopropane (120m).**¹⁰

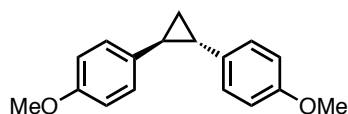

This compound was prepared using gold catalyst **C1** according to the general procedure **B**, starting from 7-(4-methoxyphenyl)cyclohepta-1,3,5-triene **118e** and 5 equiv of 1-methoxy-4-vinylbenzene, which were added in portions of 1 equiv per hour. Colorless oil (63%, 2:1 dr).

Signals for *trans* stereoisomer: ^1H NMR (400 MHz, CDCl_3) δ 7.07 (d, $J = 8.7$ Hz, 4H), 6.89-6.80 (m, 4H), 3.79 (s, 6H), 2.04 (t, $J = 7.4$ Hz, 2H), 1.30 (t, $J = 7.3$ Hz, 2H). ^{13}C NMR (126 MHz, CDCl_3) δ 158.0, 134.9, 127.1, 114.1, 55.6, 27.0, 23.4, 17.6.

Signals for *cis* stereoisomer: ^1H NMR (400 MHz, CDCl_3) δ 6.89-6.80 (m, 4H), 6.64 (d, $J = 8.8$ Hz, 4H), 3.71 (s, 6H), 2.35 (dd, $J = 8.7, 6.1$ Hz, 2H), 1.39 (td, $J = 8.7, 5.8$ Hz, 1H), 1.20 (q, $J = 6.0$ Hz, 1H). ^{13}C NMR (126 MHz, CDCl_3) δ 157.1, 130.8, 130.1, 113.4, 55.3, 23.4, 17.6, 11.7. The spectroscopic data match with those reported in the literature.

1-Methoxy-4-(2-phenylcyclopropyl)benzene (**120n**).¹¹

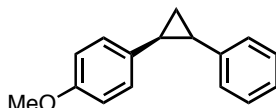

This compound was prepared using gold catalyst **C1** according to the general procedure **B**, starting from 7-phenylcyclohepta-1,3,5-triene **60a** and 5 equiv of 1-methoxy-4-vinylbenzene, which were added in portions of 1 equiv per hour. Colorless oil (57%, 1:1 dr). The spectroscopic data match with those previously described.

^1H NMR (400 MHz, CDCl_3) δ 7.28 (t, $J = 7.6$ Hz, 1H *cis* + 1H *trans*), 7.20-7.00 (m, 2H *cis* + 6H *trans*), 6.92 (d, $J = 7.8$ Hz, 2H *cis*), 6.87 (d, $J = 8.8$ Hz, 2H *cis*), 6.84 (d, $J = 8.6$ Hz, 2H *trans*), 6.64 (d, $J = 8.8$ Hz, 2H *cis*), 3.79 (s, 3H *trans*), 3.70 (s, 3H *cis*), 2.48-2.35 (m, 2H *cis*), 2.19-1.98 (m, 2H *trans*), 1.48-1.21 (m, 2H *trans* + 2H *cis*).

^{13}C NMR (101 MHz, CDCl_3) δ 158.1, 157.8, 142.9, 138.9, 134.7, 130.5, 130.3, 129.0, 128.6, 127.8, 127.1, 125.9, 125.8, 125.6, 114.1, 113.4, 55.6, 55.3, 27.7,

27.5, 24.1, 23.9, 18.0, 11.7. The spectroscopic data match with those reported in the literature.

1-Chloro-4-(2-(4-methoxyphenyl)cyclopropyl)benzene (120o).¹²

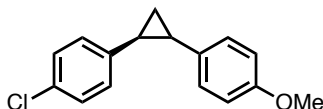

This compound was prepared using gold catalyst **C2** according to the general procedure **B**, starting from 1-chloro-4-vinylbenzene and 7-(4-methoxyphenyl)cyclohepta-1,3,5-triene **118e**. Colorless oil (56%, 1:1 dr).

¹H NMR (400 MHz, CDCl₃) δ 7.24 (d, J = 8.8 Hz, 2H *cis*), 7.08-7.03 (m, 3H *cis* + 3H *trans*), 6.88-6.80 (m, 3H *cis* + 3H *trans*), 6.66 (d, J = 8.8 Hz, 2H *trans*), 3.79 (s, 3H *trans*), 3.71 (s, 3H *cis*), 2.44 (td, J = 8.8, 6.4 Hz, 1H *cis*), 2.36 (td, J = 8.8, 6.4 Hz, 1H *cis*), 2.12-2.02 (m, 2H *trans*), 1.45 (td, J = 8.8, 5.6 Hz, 1H *cis*), 1.41-1.32 (m, 2H *trans*), 1.25 (dd, J = 12.0, 6.4 Hz, 1H *cis*).

¹³C NMR (100 MHz, CDCl₃) δ 158.2, 157.9, 141.5, 137.5, 134.3, 131.4, 131.3, 130.3, 130.2, 129.9, 128.6, 127.9, 127.3, 127.1, 114.1, 113.5, 55.6, 55.3, 27.7, 27.1, 24.0, 23.4, 18.0, 11.8. The spectroscopic data match with those reported in the literature.

1-Methoxy-4-((1*R,2*R**)-2-(4-(trifluoromethyl)phenyl)cyclopropyl)benzene (120p).**¹³

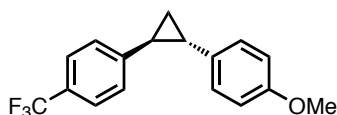

This compound was prepared using gold catalyst **C2** according to the general procedure **B**, starting from 1-(trifluoromethyl)-4-vinylbenzene and 7-(4-methoxyphenyl)cyclohepta-1,3,5-triene **118e**. Yellow oil (44%, 4.3:1 dr).

^1H NMR (400 MHz, CDCl_3) δ 7.52 (d, $J = 8.2$ Hz, 2H, *trans*), 7.32 (d, $J = 8.2$ Hz, 2H, *cis*), 7.21 (d, $J = 8.1$ Hz, 2H, *trans*), 7.07 (d, $J = 8.6$ Hz, 2H, *trans*), 6.97 (d, $J = 8.1$ Hz, 2H, *cis*), 6.89 (d, $J = 8.5$ Hz, 2H, *cis*), 6.85 (dd, $J = 9.2, 2.5$ Hz, 2H, *trans*), 6.67 (d, $J = 8.7$ Hz, 2H, *cis*), 3.79 (s, 3H, *trans*), 3.72 (s, 3H, *cis*), 2.53 (td, $J = 8.9, 6.6$ Hz, 1H, *cis*), 2.43 (td, $J = 8.9, 6.5$ Hz, 1H, *cis*), 2.21-2.09 (m, 2H, *trans*), 1.53-1.49 (m, 1H, *cis*), 1.45 (ddt, $J = 19.9, 8.8, 4.5$ Hz, 2H, *trans*), 1.33 (dd, $J = 12.0, 6.2$ Hz, 1H, *cis*).

^{13}C NMR (100 MHz, CDCl_3) δ 158.3 (*trans*), 158.1 (*cis*), 147.2 (*trans*), 143.5 (*cis*), 133.9 (*trans*), 130.5 (*trans*), 129.5 (*cis*), 128.9 (*trans*), 128.2 (*cis*), 127.9 (*cis*), 127.2 (*trans*), 126.0 (*trans*), 125.7 (*cis*), 125.5 (q, *trans*), 124.7 (q, *cis*), 123.5 (*cis*), 114.2 (*trans*), 113.6 (*cis*), 55.6 (*trans*), 55.3 (*cis*), 28.3 (*trans*), 27.5 (*trans*), 24.7 (*cis*), 23.8 (*cis*), 18.4 (*trans*), 12.2 (*cis*). The spectroscopic data match with those reported in the literature.

1-((1*R**, 2*R**)-2-(4-Fluorophenyl)cyclopropyl)-3-nitrobenzene (120q).

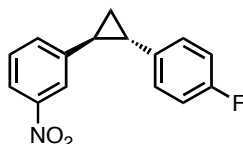

This compound was prepared using gold catalyst **C2** according to the general procedure **B**, starting from 1-nitro-3-vinylbenzene and 7-(4-fluorophenyl)cyclohepta-1,3,5-triene **118b**. Yellow oil (69%, 11:1 dr).

Signals for the *trans* stereoisomer: ^1H NMR (400 MHz, CDCl_3) δ 7.90 (ddd, $J = 8.1, 2.2, 1.1$ Hz, 1H), 7.81 (t, $J = 2.0$ Hz, 1H), 7.23 (t, $J = 7.9$ Hz, 1H), 7.14 (dd, $J = 5.2, 4.1$ Hz, 1H), 6.92 (ddd, $J = 8.2, 5.0, 2.2$ Hz, 2H), 6.80 (t, $J = 8.8$ Hz, 2H), 2.55 (ddd, $J = 15.2, 11.9, 6.4$ Hz, 2H), 1.58 (dt, $J = 8.6, 4.3$ Hz, 1H), 1.45 (dd, $J = 12.4, 6.1$ Hz, 1H).

^{13}C NMR (100 MHz, CDCl_3) δ 161.3 (d, $J = 244$ Hz), 148.0, 140.9, 134.8, 130.8 (d, $J = 8$ Hz), 128.7, 123.7 (d, $J = 3$ Hz), 123.6, 121.0, 115.1 (d, $J = 21$ Hz), 24.5, 23.7, 11.6. HRMS-APCI calcd for $\text{C}_{15}\text{H}_{12}\text{FNO}_2$ ($M+\text{H}$) $^+$: 258.0930; found: 258.0928.

Selected signals for the *cis* stereoisomer: ^1H NMR (400 MHz, CDCl_3) δ 8.04 (ddd, $J = 8.1, 2.2, 1.1$ Hz, 1H), 7.97 (t, $J = 2.0$ Hz, 1H), 7.49-7.42 (m, 2H), 7.12-7.08 (m, 2H), 7.00 (t, $J = 8.8$ Hz, 2H), 2.27-2.18 (m, 2H), 1.51 (t, $J = 1.2$ Hz, 1H), 1.49 (d, $J = 1.2$ Hz, 1H).

^{13}C NMR (100 MHz, CDCl_3) δ 144.8, 132.4, 129.4, 127.6 (d, $J = 8$ Hz), 121.1, 120.6, 115.5 (d, $J = 21$ Hz), 28.1, 27.4, 18.6.

1-((1*R*^{*}, 2*R*^{*})-2-(4-Chlorophenyl)cyclopropyl)-3-nitrobenzene (120r).

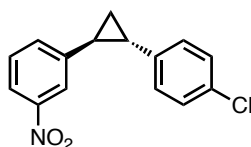

This compound was prepared using gold catalyst **C2** according to the general procedure **B**, starting from 1-nitro-3-vinylbenzene and 7-(4-chlorophenyl)cyclohepta-1,3,5-triene **118c**. Yellow oil that solidifies in the freezer (74%, 28:1 dr).

Signals for the *trans* stereoisomer. ^1H NMR (400 MHz, CDCl_3) δ 7.93-7.89 (m, 1H), 7.84 (t, $J = 1.9$ Hz, 1H), 7.23 (d, $J = 8.0$ Hz, 1H), 7.16 (d, $J = 7.7$ Hz, 1H), 7.11-7.05 (m, 2H), 6.91-6.85 (m, 2H), 2.57 (dd, $J = 8.5, 6.4$ Hz, 2H), 1.58 (td, $J = 8.6, 5.9$ Hz, 1H), 1.46 (q, $J = 6.2$ Hz, 1H).

^{13}C NMR (100 MHz, CDCl_3) δ 148.1, 140.7, 135.7, 134.9, 132.2, 130.5, 128.8, 128.4, 123.7, 121.2, 24.6, 24.0, 11.6. HRMS-APCI calcd for $\text{C}_{15}\text{H}_{12}\text{ClNO}_2$ (M)⁺: 273.0557; found: 273.0555.

1-((1*R*^{*}, 2*R*^{*})-2-(4-Bromophenyl)cyclopropyl)-3-nitrobenzene (120s).

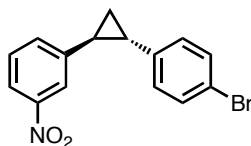

This compound was prepared as single stereoisomer, using gold catalyst **C2** according to the general procedure **B**, from 1-nitro-3-vinylbenzene and 7-(4-bromophenyl)cyclohepta-1,3,5-triene **118d**. Yellow oil that solidifies in the freezer (70%).

^1H NMR (400 MHz, CDCl_3) δ 7.92 (d, $J = 8.3$ Hz, 1H), 7.85 (t, $J = 1.9$ Hz, 1H), 7.23 (dd, $J = 8.0, 5.9$ Hz, 3H), 7.16 (d, $J = 7.7$ Hz, 1H), 6.82 (d, $J = 8.4$ Hz, 2H), 2.60-2.52 (m, 2H), 1.58 (td, $J = 8.5, 5.9$ Hz, 1H), 1.46 (q, $J = 6.2$ Hz, 1H).

^{13}C NMR (100 MHz, CDCl_3) δ 148.1, 140.6, 136.3, 134.9, 131.3, 130.9, 128.8, 123.9, 121.1, 120.3, 24.6, 24.1, 11.5. HRMS-APCI calcd for $\text{C}_{15}\text{H}_{12}\text{BrNO}_2$ (M) $^+$: 317.0051; found: 317.0067.

1-((1*R**,2*R**)-2-(4-Methoxyphenyl)cyclopropyl)-3-nitrobenzene (**120t**).

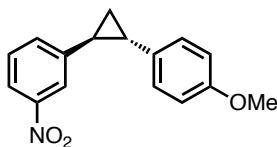

This compound was prepared using gold catalyst **C2** according to the general procedure **B**, starting from 1-nitro-3-vinylbenzene and 7-(4-methoxyphenyl)cyclohepta-1,3,5-triene **118e**. Beige solid mp 91.5-93 °C (77%, 4.5:1 dr). After one crystallization, single crystals were obtained (see end of experimental section for crystallographic X-ray data).

^1H NMR (400 MHz, CDCl_3) δ 8.02 (dt., $J = 8.5, 2$ Hz, 1H *cis*), 7.96 (t, $J = 1.8$ Hz, 1H *cis*), 7.88 (ddd, $J = 17.6, 10.8, 4.7$ Hz, 1H *trans*), 7.81 (t, $J = 1.8$ Hz, 1H *trans*), 7.45 (ddd, $J = 17.6, 10.8, 4.7$ Hz, 2H *cis*), 7.21 (t, $J = 7.9$ Hz, 1H *trans*), 7.15 (d, $J = 7.7$ Hz, 1H *trans*), 7.09 (d, $J = 8.7$ Hz, 2H *cis*), 6.89 (d, $J = 8.5$ Hz, 2H *trans*), 6.86 (d, $J = 8.7$ Hz, 2H *cis*), 6.66 (d, $J = 8.7$ Hz, 2H *trans*), 3.80 (s, 3H *cis*), 3.70 (s, 3H *trans*), 2.57 (td, $J = 15.3, 8.7$ Hz, 1H *trans*), 2.49 (td, $J = 15.0, 8.8$ Hz, 1H *trans*), 2.20 (qd, $J = 10.6, 4.6$ Hz, 2H *cis*), 1.57-1.53 (m, 1H *trans*), 1.49 (ddt, $J = 20.0, 8.8, 5.7$ Hz, 2H *cis*), 1.42 (dd, $J = 12.2, 6.1$ Hz, 1H *trans*).

^{13}C NMR (100 MHz, CDCl_3) δ 158.4 (*cis*), 158.2 (*trans*), 148.7 (*cis*), 148.0 (*trans*), 145.3 (*cis*), 141.5 (*trans*), 134.8 (*trans*), 133.5 (*cis*), 132.4 (*cis*), 130.4 (*trans*), 129.4 (*cis*), 128.9 (*trans*), 128.5 (*trans*), 127.2 (*cis*), 123.6 (*trans*), 120.9 (*cis*), 120.8 (*trans*), 120.5 (*cis*), 114.2 (*cis*), 113.7 (*trans*), 55.6 (*cis*), 55.3 (*trans*), 28.3 (*cis*), 27.2 (*cis*), 24.7 (*trans*), 23.6 (*trans*), 18.4 (*cis*), 11.7 (*trans*). HRMS-APCI calcd for $\text{C}_{15}\text{H}_{15}\text{NO}_3$ ($M+H$) $^+$: 270.1130; found: 270.1130.

1-Methyl-2-((1*R*^{*}, 2*R*^{*})-2-(3-nitrophenyl)cyclopropyl)benzene (120u).

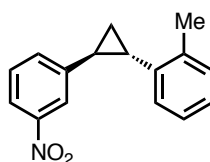

This compound was prepared using gold catalyst **C2** according to the general procedure **B**, starting from 1-nitro-3-vinylbenzene and 7-(*o*-tolyl)cyclohepta-1,3,5-triene **118f**. Yellow oil (81%, 26:1 dr).

Signals for the *trans* stereoisomer: ^1H NMR (400 MHz, CDCl_3) δ 7.84 (ddd, J = 8.1, 2.3, 1.1 Hz, 1H), 7.70 (t, J = 2.0 Hz, 1H), 7.20 (d, J = 7.5 Hz, 1H), 7.16-7.09 (m, 2H), 7.08-7.02 (m, 2H), 6.95 (d, J = 7.4 Hz, 1H), 2.60-2.54 (m, 2H), 2.10 (s, 3H), 1.63 (td, J = 8.6, 5.8 Hz, 1H), 1.55 (dd, J = 12.4, 6.4 Hz, 1H).

^{13}C NMR (100 MHz, CDCl_3) δ 147.7, 141.7, 138.6, 134.7, 133.2, 129.8, 129.2, 128.3, 126.9, 125.8, 122.2, 120.6, 25.5, 23.2, 19.8, 12.3. HRMS-APCI calcd for $\text{C}_{16}\text{H}_{15}\text{NO}$ ($M+H$) $^+$: 254.1181; found: 254.1179.

2-((1*R*^{*}, 2*R*^{*})-2-(3-Nitrophenyl)cyclopropyl)dibenzo[*b,d*]furan (120v).

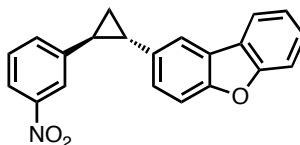

This compound was prepared using gold catalyst **C2** according to the general procedure **B**, starting from 1-nitro-3-vinylbenzene and 3-(cyclohepta-2,4,6-trien-1-yl)dibenzo[*b,d*]furan **118h**. Yellow oil (79%, 11:1 dr).

Signals for the *trans* stereoisomer: ^1H NMR (400 MHz, CDCl_3) δ 7.91 (dd, $J = 2.2, 1.5$ Hz, 1H), 7.88-7.78 (m, 2H), 7.63-7.59 (m, 1H), 7.52-7.48 (m, 1H), 7.41 (ddd, $J = 8.3, 7.3, 1.3$ Hz, 1H), 7.30 (dt, $J = 6.5, 1.0$ Hz, 2H), 7.18-7.10 (m, 2H), 7.06 (ddd, $J = 8.5, 1.8, 0.6$ Hz, 1H), 2.80 (td, $J = 8.8, 6.5$ Hz, 1H), 2.60 (td, $J = 8.8, 6.2$ Hz, 1H), 1.67 (td, $J = 8.6, 5.8$ Hz, 1H), 1.60 (dd, $J = 12.3, 6.1$ Hz, 1H).

^{13}C NMR (100 MHz, CDCl_3) δ 156.6, 155.0, 148.0, 141.2, 134.5, 131.5, 128.7, 128.6, 127.3, 124.3, 124.2, 123.7, 122.8, 121.3, 120.9, 120.7, 111.9, 111.3, 25.4, 23.9, 12.0. HRMS-APCI calcd for $\text{C}_{21}\text{H}_{15}\text{NO}_3$ ($M+H$) $^+$: 330.1130; found: 330.1130.

1-Fluoro-4-((2*R*^{*})-2-(4-methylbenzyl)cyclopropyl)benzene (**120w**).

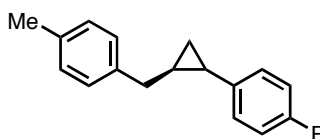

This compound was prepared as mixture of stereoisomers using gold catalyst **C2** according to the general procedure **B**, starting from 1-allyl-4-methylbenzene and 7-(4-fluorophenyl)cyclohepta-1,3,5-triene **118b**. Colorless oil (59%, 1:1 dr).

^1H NMR (400 MHz, CDCl_3) δ 7.16 (ddd, $J = 24.8, 11.8, 6.8$ Hz, 6H *cis* + *trans*), 7.05 (d, $J = 7.8$ Hz, 2H *cis* + *trans*), 7.01-6.90 (m, 8H *cis* + *trans*), 2.76 (dd, $J = 14.7, 6.7$ Hz, 1H *cis* + *trans*), 2.65 (dd, $J = 14.8, 6.8$ Hz, 1H *cis* + *trans*), 2.44 (dd, $J = 15.0, 6.4$ Hz, 1H *cis* + *trans*), 2.33 (s, 3H *cis* + *trans*), 2.31 (s, 3H *cis* + *trans*), 2.16 (ddd, $J = 22.9, 14.8, 8.2$ Hz, 2H *cis* + *trans*), 1.81-1.74 (m, 1H *cis* + *trans*), 1.45-1.35 (m, 1H *cis* + *trans*), 1.27 (dt, $J = 6.6, 3.9$ Hz, 1H *cis* + *trans*), 1.08 (td, $J = 8.4, 5.2$ Hz, 1H *cis* + *trans*), 0.94-0.88 (m, 2H *cis* + *trans*), 0.79 (dd, $J = 11.2, 5.7$ Hz, 1H *cis* + *trans*).

^{13}C NMR (100 MHz, CDCl_3) δ 161.5 (d, $J = 237$ Hz), 161.1 (d, $J = 242$ Hz), 143.2 (d, $J = 3$ Hz), 138.9, 138.3, 135.7, 135.4, 135.0 (d, $J = 3$ Hz), 130.7 (d, $J =$

8 Hz), 129.3, 129.1, 128.4, 128.3, 127.3 (d, $J = 7$ Hz), 115.1 (d, $J = 21$ Hz), 114.9 (d, $J = 21$ Hz), 39.7, 34.3, 24.3, 22.8, 21.24, 21.2, 20.8, 20.0, 15.9, 10.3. HRMS-APCI calcd for $C_{17}H_{17}F$ (M)⁺: 240.1314; found: 240.1318.

1-Fluoro-4-((1*R*^{*},2*S*^{*},3*S*^{*})-2-phenyl-3-((*E*)-styryl)cyclopropyl)benzene (120x).

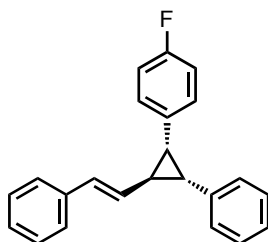

This compound was prepared as mixture of stereoisomers, using gold catalyst **C2** according to the general procedure **B**, starting from (1*E*,3*E*)-1,4-diphenylbuta-1,3-diene and 7-(4-fluorophenyl)cyclohepta-1,3,5-triene **118b**. Viscous yellow oil (62% combined yield, 1.3:1 dr).

Signals for main stereoisomer: ¹H NMR (500 MHz, CDCl₃) δ 7.41 (dd, $J = 11.7$, 4.5 Hz, 2H *trans*), 7.35 (ddd, $J = 13.6$, 6.6, 3.8 Hz, 2H *trans*), 7.29-7.23 (m, 2H *trans*), 7.23-7.13 (m, 2H *trans*), 7.00-6.94 (m, 4H *trans*), 6.86 (t, $J = 8.8$ Hz, 2H *trans*), 6.69 (d, $J = 15.8$ Hz, 1H *trans*), 6.19 (dd, $J = 15.8$, 8.1 Hz, 1H *trans*), 2.66 (d, $J = 5.6$ Hz, 2H *trans*), 2.47 (dt, $J = 8.1$, 5.5 Hz, 1H *trans*).

¹³C NMR (126 MHz, CDCl₃) δ 161.8 (d, $J = 245$ Hz), 137.5, 137.4, 133.9 (d, $J = 3$ Hz), 130.6, 130.62 (d, $J = 8$ Hz), 129.0 (x2), 128.8, 128.1, 127.2, 126.3, 126.0, 114.9 (d, $J = 21$ Hz), 33.2, 32.7, 30.1. HRMS-APCI calcd for $C_{23}H_{19}F$ ($M+H$)⁺: 315.1549; found: 315.1550.

1-Fluoro-4-((1*S*^{*},2*R*^{*},3*S*^{*})-2-phenyl-3-((*E*)-styryl)cyclopropyl)benzene. Minor stereoisomer: ¹H NMR (500 MHz, CDCl₃) δ 7.41 (dd, $J = 11.7$, 4.5 Hz, 1H *cis*), 7.35 (ddd, $J = 13.6$, 6.6, 3.8 Hz, 4H *cis*), 7.29-7.23 (m, 3H *cis*), 7.23-7.13 (m, 4H *cis*), 7.05 (t, $J = 8.7$ Hz, 2H *cis*), 6.59 (d, $J = 15.8$ Hz, 1H *cis*), 5.67 (dd, $J = 15.8$, 9.4 Hz, 1H *cis*), 2.84 (dd, $J = 8.9$, 6.2 Hz, 1H *cis*), 2.57 (t, $J = 5.5$ Hz, 1H *cis*), 2.35 (td, $J = 9.3$, 4.9 Hz, 1H *cis*).

^{13}C NMR (126 MHz, CDCl_3) δ 161.8 (d, $J = 247$ Hz), 141.6, 137.6, 133.2 (d, $J = 3$ Hz), 132.1, 131.0 (d, $J = 8$ Hz), 129.3, 128.9, 128.78, 128.7, 127.1, 126.2, 125.9, 115.3 (d, $J = 21$ Hz), 34.0, 32.9, 31.5.

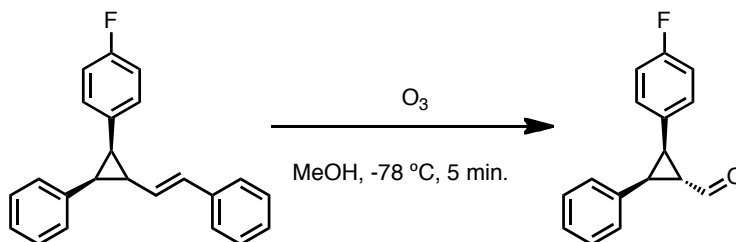

(1*R*^{*},2*R*^{*},3*S*^{*})-2-(4-fluorophenyl)-3-phenylcyclopropanecarbaldehyde (120y).

Compound **120x** (50 mg, 0.159 mmol) was dissolved in CH_2Cl_2 (10 mL) and cooled to $-78\text{ }^\circ\text{C}$. Ozone was bubbled through the solution and the reaction progress was closely monitored by TLC. After 5 min the reaction was completed, the ozone flow was discontinued and the reaction mixture was purged with argon for 15 min. Triphenylphosphine (416 mg, 10 equiv) was then added to the reaction mixture and the resulting clear solution was allowed to warm to room temperature. The residue was purified by flash column chromatography to isolate the *trans* stereoisomer as a yellow oil (17.6 mg, 46%).

^1H NMR (400 MHz, CDCl_3) δ 9.66 (d, $J = 4.1$ Hz, 1H), 7.19-7.13 (m, 3H), 6.96-6.88 (m, 4H), 6.84 (t, $J = 8.7$ Hz, 2H), 3.15 (d, $J = 5.1$ Hz, 2H), 2.79 (td, $J = 5.1$, 4.1 Hz, 1H).

^{13}C NMR (126 MHz, CDCl_3) δ 199.7, 161.0 (d, $J = 246$ Hz), 134.8, 130.7, 130.6, 129.0, 128.4, 127.1, 115.2 (d, $J = 21$ Hz), 37.02, 33.58, 32.88. HRMS-APCI calcd for $\text{C}_{17}\text{H}_{17}\text{F}$ ($M+\text{H}$)⁺: 241.1029; found: 241.1039. The relative configuration for this compound was assigned based on a NOESY experiment.

1-Nitro-3-((1*R*^{*},2*S*^{*})-2-((*E*)-styryl)cyclopropyl)benzene (120z).

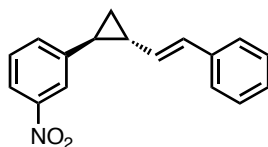

This compound was prepared using gold catalyst **C1** according to the general procedure **B**, starting from 1-nitro-3-vinylbenzene (10 equiv) and (*E*)-7-styrylcyclohepta-1,3,5-triene **120i** (1 equiv). Colorless oil (21%, 10:1 dr).

Signals for the *trans* stereoisomer: ^1H NMR (400 MHz, CDCl_3) δ 8.12 (s, 1H), 8.06 (d, $J = 8.1$ Hz, 1H), 7.57 (d, $J = 7.7$ Hz, 1H), 7.43 (t, $J = 7.9$ Hz, 1H), 7.21 (t, $J = 7.2$ Hz, 2H), 7.17-7.10 (m, 3H), 6.54 (d, $J = 15.7$ Hz, 1H), 5.45 (dd, $J = 15.7$, 9.1 Hz, 1H), 2.51 (m, 1H), 2.14 (qd, $J = 8.8$, 5.9 Hz, 1H), 1.48 (td, $J = 8.4$, 5.6 Hz, 1H), 1.24 (dd, $J = 11.9$, 5.8 Hz, 1H).

^{13}C NMR (126 MHz, CDCl_3) δ 148.3, 141.3, 137.3, 135.6, 131.2, 129.1, 128.8, 128.6, 127.1, 125.9, 124.0, 121.4, 23.7, 23.3, 12.9. HRMS-APCI calcd for $\text{C}_{17}\text{H}_{16}\text{NO}_2$ ($M+\text{H}$) $^+$: 266.1181; found 266.1175

Selected signals for the *cis* stereoisomer: 5.91 (dd, $J = 15.8$, 8.6 Hz, 1H), 1.91 (dt, $J = 8.6$, 6.7 Hz, 1H), 1.42-1.32 (m, 1H).

(1*R*^{*},1*aR*^{*},6*aR*^{*})-4-Chloro-1-phenyl-1,1*a*,6,6*a*-tetrahydrocyclopropa[*a*]indene (120aa**).**

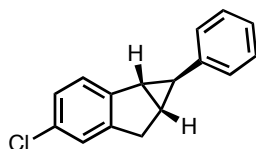

This compound was prepared using gold catalyst **C1** according to the general procedure **B**, starting from 6-chloro-1*H*-indene¹⁴ and 7-phenylcyclohepta-1,3,5-triene **118a**. Colorless oil (82%, 15.5:1 dr).

Signals for the *exo* stereoisomer: ^1H NMR (400 MHz, CDCl_3) δ 7.25 (d, $J = 8.0$ Hz, 1H), 7.18 (d, $J = 8.3$ Hz, 2H), 7.06-7.02 (m, 1H), 6.80 (dd, $J = 8.3$, 1.0 Hz, 2H), 6.76 (s, 1H), 3.09 (dd, $J = 17.6$, 7.0 Hz, 1H), 2.87 (ddd, $J = 8.1$, 6.2, 1.5 Hz, 1H), 2.62 (d, $J = 17.6$ Hz, 1H), 2.37 (t, $J = 8.2$ Hz, 1H), 2.31-2.23 (m, 1H).

^{13}C NMR (101 MHz, CDCl_3) δ 145.1, 141.4, 134.4, 132.8, 131.4, 131.1, 126.4, 125.5, 124.8, 120.0, 31.9, 29.5, 26.7, 22.8. HRMS-APCI calcd for $\text{C}_{16}\text{H}_{13}\text{Cl}$ ($M+\text{H}$) $^+$: 240.0705; found 240.0706.

(1*R*^{*},1*aR*^{*},6*aR*^{*})-1-(4-Bromophenyl)-4-chloro-1,1*a*,6,6*a*-tetrahydrocyclopropa[*a*]indene (120ab).

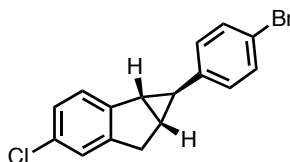

This compound was prepared using gold catalyst **C1** according to the general procedure **B**, starting from 6-chloro-1*H*-indene¹⁴ and 7-(4-bromophenyl)cyclohepta-1,3,5-triene **118d**. White solid m.p. 139-141 °C (47%, 20:1 dr).

Signals for *exo* stereoisomer. ¹H NMR (400 MHz, CDCl₃) δ 7.25 (d, *J* = 8.0 Hz, 1H), 7.18 (d, *J* = 8.3 Hz, 2H), 7.06 -7.02 (m, 1H), 6.80 (dd, *J* = 8.3, 1.0 Hz, 2H), 6.76 (s, 1H), 3.09 (dd, *J* = 17.6, 7.0 Hz, 1H), 2.87 (ddd, *J* = 8.1, 6.2, 1.5 Hz, 1H), 2.62 (d, *J* = 17.6 Hz, 1H), 2.37 (t, *J* = 8.2 Hz, 1H), 2.31-2.23 (m, 1H).

¹³C NMR (101 MHz, CDCl₃) δ 145.1, 141.4, 134.4, 132.8, 131.4, 131.1, 126.4, 125.5, 124.8, 120.0, 31.9, 29.5, 26.7, 22.8. HRMS-APCI calcd for C₁₆H₁₂ClBr (*M*+H)⁺: 317.9811; found 317.9812.

(1*R*^{*},1*aR*^{*},6*aR*^{*})-4-Chloro-1-(4-methoxyphenyl)-1,1*a*,6,6*a*-tetrahydrocyclopropa[*a*]indene (120ac).

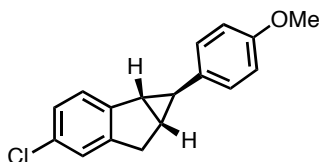

This compound was prepared as mixture of stereoisomers using gold catalyst **C1** according to the general procedure **B**, starting from 6-chloro-1*H*-indene¹⁴ and 7-(4-methoxyphenyl)cyclohepta-1,3,5-triene **118e**. Colorless oil (75%, 1.2:1 dr).

¹H NMR (400 MHz, CDCl₃) δ 7.24 (d, *J* = 8.0 Hz, 1H, *exo*), 7.20 (d, *J* = 8.0 Hz, 1H, *syn*), 7.15 (s, 1H, *syn*), 7.09 (dd, *J* = 8.0, 2.0 Hz, 1H, *syn*), 7.02 (dd, *J* = 8.0,

1.8 Hz, 1H, *exo*), 6.96 (d, $J = 8.7$ Hz, 2H, *exo*), 6.89-6.80 (m, 4H, *syn*), 6.73 (s, 1H, *exo*), 6.60 (d, $J = 8.7$ Hz, 2H, *exo*), 3.78 (s, 3H, *syn*), 3.68 (s, 3H, *exo*), 3.30 (dd, $J = 17.5, 6.7$ Hz, 1H, *syn*), 3.14-2.99 (m, 1H *cis* + 1H *exo*), 2.85-2.80 (m, 1H, *exo*), 2.65 (d, $J = 17.5$ Hz, 1H, *exo*), 2.59-2.51 (m, 1H, *cis*), 2.37 (t, $J = 8.3$ Hz, 1H, *exo*), 2.24-2.20 (m, 1H, *exo*), 2.17-2.02 (m, 1H, *syn*), 1.45 (t, $J = 3.2$ Hz, 1H, *syn*).

^{13}C NMR (101 MHz, CDCl_3) δ 158.0, 157.7, 145.5, 144.7, 144.5, 141.9, 134.0, 132.0, 131.4, 131.0, 127.2, 126.5, 126.4, 126.1, 125.7, 125.4, 124.6, 124.5, 114.1, 113.4, 55.5, 55.2, 36.3, 35.3, 33.9, 31.9, 29.6, 27.5, 26.5, 22.8. HRMS-APCI calcd for $\text{C}_{17}\text{H}_{16}\text{OCl}$ ($M+\text{H}$) $^+$: 271.0890; found 271.0887.

1-Fluoro-4-((1*R*^{*},2*S*^{*},3*S*^{*})-2-methyl-3-phenylcyclopropyl)benzene (**120ad**).

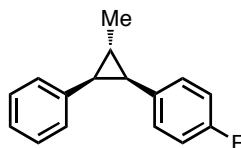

This compound was prepared as mixture of stereoisomers using gold catalyst **C1** according to the general procedure **B**, starting from (*E*)-prop-1-en-1-ylbenzene and 7-(4-fluorophenyl)cyclohepta-1,3,5-triene **118b**. Colorless oil (62% combined yield, 4:1 dr).

Signals for the main stereoisomer: ^1H NMR (400 MHz, CDCl_3) δ 7.17-7.08 (m, 3H), 6.95-6.88 (m, 4H), 6.82 (t, $J = 8.8$ Hz, 2H), 2.21 (d, $J = 5.6$ Hz, 1H), 1.71 (dd, $J = 11.6, 5.8$ Hz, 1H), 1.43 (d, $J = 5.9$ Hz, 2H).

^{13}C NMR (100 MHz, CDCl_3) δ 161.2 (d, $J = 244$ Hz), 138.6, 134.4 (d, $J = 3$ Hz), 130.5 (d, $J = 8$ Hz), 128.9, 127.9, 125.4, 114.7 (d, $J = 21$ Hz), 32.9, 32.5, 20.2, 19.2. HRMS-APCI calcd for $\text{C}_{16}\text{H}_{15}\text{F}$ (M) $^+$: 226.1158; found: 226.1165. The relative configuration for this compound was assigned based on a NOESY experiment.

1-Fluoro-4-((1*R*^{*},2*R*^{*},3*R*^{*})-2-methyl-3-phenylcyclopropyl)benzene. Minor stereoisomer: ^1H NMR (400 MHz, CDCl_3) δ 7.37-7.36 (m, 2H), 7.32-7.25 (m,

3H), 7.22 (d, $J = 8.0$ Hz, 2H), 7.04 (t, $J = 8.8$ Hz, 2H), 2.46 (dd, $J = 9.1, 5.3$ Hz, 1H), 2.08 (t, $J = 5.3$ Hz, 1H), 1.61-1.52 (m, 1H), 1.02 (d, $J = 6.2$ Hz, 3H).

Selected signals ^{13}C NMR (100 MHz, CDCl_3) δ 130.8 (d, $J = 7$ Hz), 128.6, 126.1, 125.8, 115.1 (d, $J = 7$ Hz), 32.0, 30.2, 23.9, 13.8.

1-Chloro-4-((1*R**,2*S**,3*S**)-2-methyl-3-phenylcyclopropyl)benzene (**120ae**).

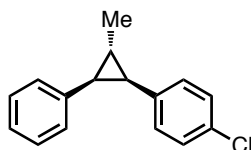

This compound was prepared as mixture of stereoisomers using gold catalyst **C1** according to the general procedure **B**, starting from (*E*)-prop-1-en-1-ylbenzene and 7-(4-chlorophenyl)cyclohepta-1,3,5-triene **118c**. Colorless oil (67% combined yield, 3.2:1 dr).

Signals for the main stereoisomer: ^1H NMR (400 MHz, CDCl_3) δ 7.14-7.07 (m, 3H), 7.05 (d, $J = 8.5$ Hz, 2H), 6.90 (m, 2H), 6.82 (d, $J = 8.5$ Hz, 2H), 2.22 (dd, $J = 9.3, 5.7$ Hz, 1H), 2.14 (dd, $J = 9.3, 5.7$ Hz, 1H), 1.68 (dd, $J = 11.7, 5.8$ Hz, 1H), 1.39 (d, $J = 5.9$ Hz, 3H).

^{13}C NMR (100 MHz, CDCl_3) δ 138.3, 137.5, 130.7, 130.3, 129.1, 128.0, 127.9, 125.9, 33.3, 32.5, 20.3, 19.2. HRMS-APCI calcd for $\text{C}_{16}\text{H}_{15}\text{Cl}$ (M^+): 242.0862; found: 242.0879. The relative configuration for this compound was assigned based on a NOESY experiment.

1-Chloro-4-((1*S**,2*S**,3*S**)-2-methyl-3-phenylcyclopropyl)benzene. Minor stereoisomer: ^1H NMR (400 MHz, CDCl_3) δ 7.34-7.25 (m, 4H), 7.23-7.14 (m, 5H), 2.41 (dd, $J = 9.3, 5.4$ Hz, 1H), 2.06 (t, $J = 5.3$ Hz, 1H), 1.60-1.54 (m, 1H), 0.99 (d, $J = 6.3$ Hz, 3H). ^{13}C NMR (100 MHz, CDCl_3) δ 142.8, 137.3, 131.3, 128.6, 128.4, 126.1, 125.92, 125.9, 32.1, 30.2, 24.1, 13.7.

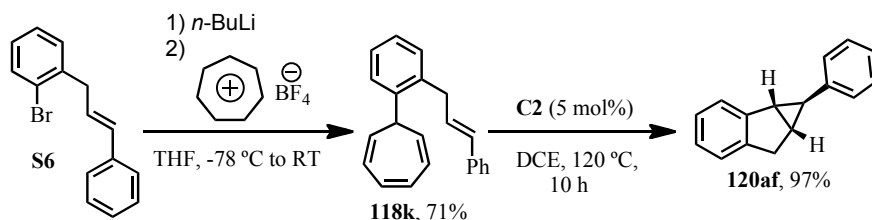
Intramolecular Cyclopropanation.**(1*R**,1*aR**,6*aR**)-1-Phenyl-1,1*a*,6,6*a*-tetrahydrocyclopropa[*a*]indene (**120af**).¹⁵**

This compound was synthesized in 97% yield as a yellow oil following the general procedure **B**, starting from **118k** and gold catalyst **C2**.

¹H NMR (500 MHz, CDCl₃) δ 7.33-7.30 (m, 1H), 7.27 (t, *J* = 7.6 Hz, 2H), 7.18-7.23 (m, 1H), 7.16 (t, *J* = 7.6 Hz, 1H), 7.14-7.09 (m, 2H), 7.04 (dd, *J* = 8.1, 1.1 Hz, 2H), 3.34 (dd, *J* = 17.3, 6.6 Hz, 1H), 3.14 (d, *J* = 17.3 Hz, 1H), 2.74-2.64 (m, 1H), 2.26-2.11 (m, 1H), 1.50 (t, *J* = 3.1 Hz, 1H).

¹³C NMR (126 MHz, CDCl₃) δ 146.0, 142.6, 142.5, 128.5, 126.3, 125.9, 125.7, 125.5, 125.5, 123.7, 36.5, 36.5, 34.6, 27.9. The spectroscopic data match with those reported in the literature.

(*E*)-7-(2-Cinnamylphenyl)cyclohepta-1,3,5-triene (**118k**). This compound was prepared a viscous yellow oil in 71% yield according to the general procedure **C1**, starting from **S6**⁷ (1 equiv) and tropylium tetrafluoroborate (1.5 equiv). ¹H NMR (400 MHz, CDCl₃) δ 7.53 (d, *J* = 7.6 Hz, 1H), 7.36-7.30 (m, 1H), 7.29-7.23 (m, 6H), 7.22-7.14 (m, 1H), 6.75-6.70 (t, *J* = 3.6 Hz, 2H), 6.37-6.15 (m, 4H), 5.37 (dd, *J* = 8.8, 5.4 Hz, 2H), 3.46 (d, *J* = 5.1 Hz, 2H), 3.02 (t, *J* = 5.4 Hz, 1H). ¹³C NMR (126 MHz, CDCl₃) δ 142.4, 138.2, 137.8, 131.2, 131.0, 130.2, 129.2, 128.6, 127.6, 127.3, 127.1, 126.9, 126.8, 126.2, 124.7, 41.5, 36.8. HRMS-APCI calcd for C₂₂H₂₀ (*M*-H)⁺: 283.1487; found: 283.1487.

Free carbene oxidation

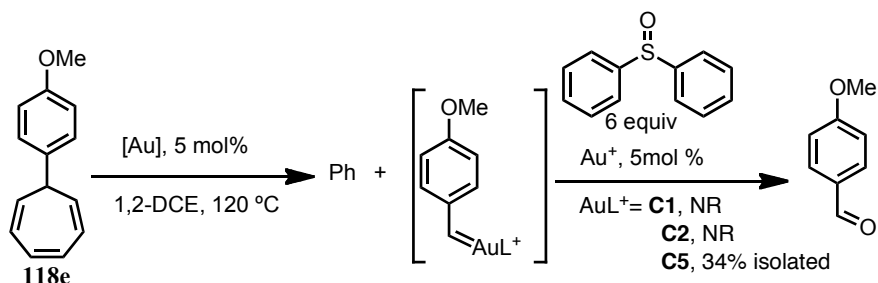

In three different oven-dried sealable Schlenk, cycloheptatriene **118e** (50.0 mg, 0.253 mmol) was mixed with diphenyl sulfoxide (203.5 mg, 1.518 mmol, 6 equiv), gold catalyst **C1** (0.013 mmol, 10.3 mg, 5 mol%), gold catalyst **C2** (0.013 mmol, 12.2 mg, 5 mol%), gold catalyst **C5** (0.013 mmol, 12.6 mg, 5 mol%) and 0.5 mL of 1,2-DCE in each Schlenk. The three reaction were then heated at 120 °C by a period of 3 h, in which time was not observed starting **118e**. Catalysts, **C1** and **C2** did not yield any oxidation product, while with gold catalyst **C5**, was possible to isolate *p*-anisaldehyde in 34% yield.

The spectroscopic data match with those reported in the literature.

11aH-Cyclohepta[a]naphthalene (121a) and **11H-cyclohepta[a]naphthalene (121b)**.

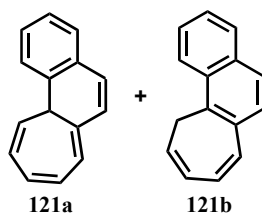

This mixture of compounds were synthesized in 49% (**121a**) and 41% (**121b**) yield following the general procedure **B**, starting from **118j** and gold catalyst **C1**.

11aH-Cyclohepta[a]naphthalene (121a). 1H NMR (500 MHz, $CDCl_3$) δ 7.40 (d, $J = 7.4$ Hz, 1H), 7.24 (dq, $J = 21.3, 7.2$ Hz, 5H), 7.18 – 7.07 (m, 3H), 6.95 – 6.85 (m, 1H), 6.60 (dd, $J = 5.4, 1.8$ Hz, 1H), 4.60 (s, 1H).

^{13}C NMR (126 MHz, CDCl_3) δ 148.4, 144.2, 139.9, 139.5, 131.7, 128.8(x2), 128.0(x2), 126.99, 126.96, 125.5, 124.1, 121.3, 56.7. HRMS-APCI calcd for $\text{C}_{15}\text{H}_{12}$ ($M\text{-H}$) $^+$: 193.1017; found: 193.1026.

11*H*-Cyclohepta[*a*]naphthalene (**121b**). ^1H NMR (400 MHz, CDCl_3) δ 7.67 – 7.61 (m, 2H), 7.47 (dd, $J = 7.3, 0.8$ Hz, 1H), 7.39 (ddd, $J = 7.9, 6.6, 2.9$ Hz, 3H), 7.30 – 7.22 (m, 3H), 7.18 (td, $J = 7.4, 1.2$ Hz, 1H), 3.81 – 3.78 (m, 2H).

^{13}C NMR (101 MHz, CDCl_3) δ 146.6, 145.6, 143.4, 136.2, 128.9(x2), 127.7, 126.8, 126.7, 125.9(x2), 124.9, 123.9, 121.2, 39.2. HRMS-APCI calcd for $\text{C}_{15}\text{H}_{12}$ ($M\text{-H}$) $^+$: 193.1017; found: 193.1025.

2,5-Dimethyl-11*H*-cyclohepta[*a*]naphthalene (**121c**).

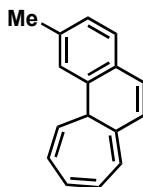

This compound was synthesized in 75% yield as a yellow oil following the general procedure **B**, starting from **118I** and gold catalyst **C1**.

^1H NMR (500 MHz, CDCl_3) δ 7.38 (d, $J = 7.4$ Hz, 1H), 7.28 – 7.22 (m, 2H), 7.13 (t, $J = 7.4$ Hz, 1H), 7.07 (d, $J = 7.9$ Hz, 2H), 6.99 (d, $J = 8.0$ Hz, 2H), 6.91 – 6.86 (m, 1H), 6.57 (dd, $J = 5.5, 1.9$ Hz, 1H), 4.57 (s, 1H), 2.30 (s, 3H).

^{13}C NMR (126 MHz, CDCl_3) δ 148.57, 144.27, 140.15, 136.57, 136.34, 131.54, 129.57, 127.89, 126.90, 125.46, 124.04, 121.30, 56.35, 21.28. HRMS-APCI calcd for $\text{C}_{16}\text{H}_{14}$ ($M\text{-H}$) $^+$: 223.1123; found: 223.1123.

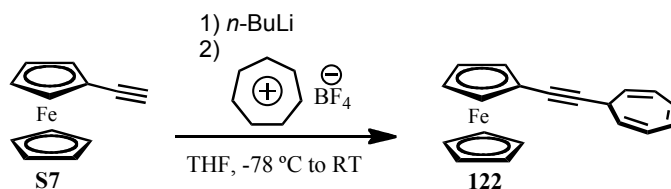
7-Ferrocenylcyclohepta-1,3,5-triene (122).

Ethynylferrocene **S7** (210.1 mg, 1.0 mmol) was dissolved in THF (0.1M). The solution was cooled to $-78\text{ }^{\circ}\text{C}$ before addition of *n*-BuLi (2.6M, 0.42 mL, 1.1 mmol, 1.1 equiv). The mixture was stirred 40 min at this temperature, then solid tropylium tetrafluoroborate (185.1 mg, 1.0 mmol) was added in one portion and stirred additionally 5 h. The cooling bath was removed and the reaction was stopped by addition of NH_4Cl solution. The aqueous phase was extracted with EtOAc, the combined organic extract was dried over MgSO_4 , and the solvent was evaporated. The crude reaction mixture was purified by flash chromatography to yield **122** (230.6 mg, 77%) as orange solid. m.p. $102.9\text{--}103.6\text{ }^{\circ}\text{C}$.

^1H NMR (500 MHz, CDCl_3) δ 6.68 (dd, $J = 3.4, 2.9$ Hz, 2H), 6.20 (dddd, $J = 8.6, 3.8, 2.5, 1.5$ Hz, 2H), 5.40 (dd, $J = 8.7, 5.5$ Hz, 2H), 4.42 (s, 2H), 4.21 (s, 5H), 4.19 – 4.16 (m, 2H), 2.60 (tt, $J = 5.5, 1.4$ Hz, 1H).

^{13}C NMR (126 MHz, CDCl_3) δ 131.2, 124.8, 123.9, 87.4, 78.7, 71.6, 70.1, 68.6, 65.9, 32.6. HRMS-ESI calcd for $\text{C}_{19}\text{H}_{16}\text{Fe}$ ($M\text{-H}$) $^+$: 300.0601; found: 300.0607.

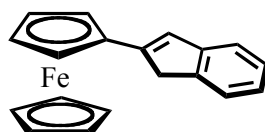
2-Indenylferrocene (123).²¹

This known compound was prepared using gold catalyst **C1** according to the general procedure **B**, starting from 7-Ferrocenylcyclohepta-1,3,5-triene (**122**). Dark orange solid (88%).

Crystallographic data for 120t

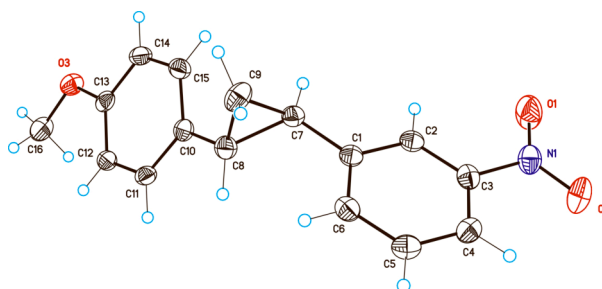

Identification code	SOAC_IV320	
Empirical formula	C ₁₆ H ₁₅ N O ₃	
Formula weight	269.29	
Temperature	293(2) K	
Wavelength	0.71073 Å	
Crystal system	Monoclinic	
Space group	P2(1)/c	
Unit cell dimensions	a = 12.306(2) Å	α = 90.00 °.
	b = 15.287(2) Å	β = 98.782(6) °.
	c = 7.0855(11) Å	γ = 90.00 °.
Volume	1317.3(4) Å ³	
Z	4	
Density (calculated)	1.358 Mg/m ³	
Absorption coefficient	0.094 mm ⁻¹	
F(000)	568	
Crystal size	0.30 x 0.10 x 0.10 mm ³	
Theta range for data collection	1.67 to 29.77 °.	
Index ranges	-17 ≤ h ≤ 17, -20 ≤ k ≤ 20, -9 ≤ l ≤ 9	
Reflections collected	7547	
Independent reflections	3271 [R(int) = 0.0367]	
Completeness to theta = 29.77 °	0.872 %	
Absorption correction	Empirical	
Max. and min. Transmisión	0.9899 and 0.9721	

Refinement method	Full-matrix least-squares on F ²
Data / restraints / parameters	3271 / 0 / 182
Goodness-of-fit on F ²	1.038
Final R indices [I>2sigma(I)]	R1 = 0.0471 , wR2 = 0.1091
R indices (all data)	R1 = 0.0648 , wR2 = 0.1189
Largest diff. peak and hole	0.313 and -0.267 e.Å ⁻³

Bond lengths [Å] and angles [°]

Bond lengths

C1-C2	1.386(2)
C1-C6	1.403(2)
C1-C7	1.482(2)
C2-C3	1.384(2)
C3-C4	1.380(2)
C3-N1	1.467(2)
C4-C5	1.386(2)
C5-C6	1.385(2)
C7-C9	1.508(2)
C7-C8	1.521(2)
C8-C10	1.485(2)
C8-C9	1.507(2)
C10-C11	1.389(2)
C10-C15	1.403(2)
C11-C12	1.388(2)
C12-C13	1.391(2)
C13-O3	1.3724(18)
C13-C14	1.393(2)
C14-C15	1.379(2)
C16-O3	1.4247(19)
N1-O1	1.2247(18)

N1-O2 1.2269(18)

Angles

C2-C1-C6 118.25(14)

C2-C1-C7 119.08(13)

C6-C1-C7 122.65(14)

C3-C2-C1 119.35(14)

C4-C3-C2 123.10(14)

C4-C3-N1 118.87(14)

C2-C3-N1 118.03(13)

C3-C4-C5 117.48(14)

C6-C5-C4 120.62(14)

C5-C6-C1 121.20(14)

C1-C7-C9 119.29(13)

C1-C7-C8 120.98(12)

C9-C7-C8 59.68(10)

C10-C8-C9 119.93(13)

C10-C8-C7 121.92(13)

C9-C8-C7 59.75(10)

C8-C9-C7 60.57(10)

C11-C10-C15 117.41(14)

C11-C10-C8 120.01(13)

C15-C10-C8 122.50(14)

C12-C11-C10 122.06(13)

C11-C12-C13 119.43(14)

O3-C13-C12 124.30(14)

O3-C13-C14 116.13(13)

C12-C13-C14 119.57(14)

C15-C14-C13 120.16(14)

C14-C15-C10 121.35(14)

O1-N1-O2	123.12(14)
O1-N1-C3	118.59(13)
O2-N1-C3	118.29(14)
C13-O3-C16	116.82(12)

Torsion angles

C6-C1-C2-C3	-0.2(2)
C7-C1-C2-C3	178.25(13)
C1-C2-C3-C4	0.8(2)
C1-C2-C3-N1	-179.56(13)
C2-C3-C4-C5	-0.8(2)
N1-C3-C4-C5	179.59(13)
C3-C4-C5-C6	0.2(2)
C4-C5-C6-C1	0.4(2)
C2-C1-C6-C5	-0.4(2)
C7-C1-C6-C5	-178.76(13)
C2-C1-C7-C9	-142.48(14)
C6-C1-C7-C9	35.9(2)
C2-C1-C7-C8	147.29(14)
C6-C1-C7-C8	-34.3(2)
C1-C7-C8-C10	-143.46(14)
C9-C7-C8-C10	108.49(16)
C1-C7-C8-C9	108.05(16)
C10-C8-C9-C7	-111.74(15)
C1-C7-C9-C8	-110.84(15)
C9-C8-C10-C11	-143.19(15)
C7-C8-C10-C11	145.85(14)
C9-C8-C10-C15	33.4(2)
C7-C8-C10-C15	-37.6(2)

C15-C10-C11-C12	-0.8(2)
C8-C10-C11-C12	175.94(13)
C10-C11-C12-C13	0.9(2)
C11-C12-C13-O3	178.87(13)
C11-C12-C13-C14	-0.9(2)
O3-C13-C14-C15	-179.09(13)
C12-C13-C14-C15	0.7(2)
C13-C14-C15-C10	-0.5(2)
C11-C10-C15-C14	0.6(2)
C8-C10-C15-C14	-176.07(13)
C4-C3-N1-O1	-173.79(15)
C2-C3-N1-O1	6.6(2)
C4-C3-N1-O2	6.6(2)
C2-C3-N1-O2	-173.05(14)
C12-C13-O3-C16	-4.5(2)
C14-C13-O3-C16	175.24(13)

References.

1. (a) Amjis, C. H. M.; López-Carrillo, V.; Raducan, M.; Pérez-Galán, P.; Ferrer, C.; Echavarren, A. M. *J. Org. Chem.* **2008**, *73*, 7721-7730. (b) Ferrer, C.; Raducan, M.; Nevado, C.; Claviere, C.K.; Echavarren, A. *Tetrahedron* **2007**, *63*, 6306-6316.
2. López-Carrillo, V.; Echavarren A. M. *J. Am. Chem. Soc.* **2010**, *132*, 9292-92944.
3. Conrow, K. *Organic Synthesis* **1963**, *43*, 101-103.
4. Manfred, C.; Erich, B.; Wolfgang, R.; Lennartz, R.; Werner, H. *Tetrahedron* **1989**, *45*, 2905-15.
5. Niem, T.; Rausch, M. D. *J. Org. Chem.* **1977**, *42*, 275-279.
6. Miura, M.; Akase, F.; Shinohara, M.; Nomura, M. *J. Chem. Soc. Perk. Trans. I* **1987**, *5*, 1021-1025.
7. Bull, J. A.; Mousseau, J. J.; Charette, A. B. *Org. Lett.* **2008**, *10*, 5485-5488.
8. Breslow, R. *J. Am. Chem Soc.* **1957**, *79*, 5318-5319.
9. Tomioka, H.; Ozaki, Y.; Koyabu, Y.; Izawa, Y. *Tetraedron Letters* **1982**, *23*, 1917-1920.
10. Gelpke, A. E.; Johan, J. N.; Marce, S. G.; Paul, C. J.; van Leeuwen, P. W. N. M.; Henk, H. *Tetrahedron*, **1999**, *55*, 6657.
11. Solorio-Alvarado, C. R.; Echavarren, A. *J. Am. Chem. Soc.* **2010**, *132*, 11881-11883
12. Beaulieu, L.P.B.; Delvos, L.B.; Charette, A.B. *Org. Lett.* **2010**, *12*, 1348-1351.
13. Kirmse, W.; Konard, W.; Özkir, I, S. *Tetrahedron*, **1997**, *53*, 9935-9964.
14. Lindsay, D. G.; McGreevy, B. J.; Reese, C. B. *Chem. Comm.* **1965**, *16*, 379-80.
15. Lamberts, J. J. M.; Laarhoven, W. H. *J. Am. Chem. Soc.* **1984**, *106*, 1736-1739.
16. Yang, L. Y.; Liu, R. S. H.; Boarman, K. L.; Wendt, N. L.; Liu, J. *J Am. Chem. Soc.* **2005**, *127*, 2404-2405.

18. Parham, W. E.; Jones, L. D.; Sayed, Y. A. *J. Org. Chem.* **1976**, *41*, 1184-1186.
19. Yang, L. Y.; Liu, R. S. H.; Boarman, K. L.; Wendt, N. L.; Liu, J. *J Am. Chem. Soc.* **2005**, *127*, 2404-2405.
20. Rauhut, C. B.; Cervino, C.; Krasovskiy, A.; Knochel, P. *Synlett* **2009**, *1*, 67-70.
21. Santi, S.; Orian, L.; Duarte, C.; Bisello, A.; Benetollo, F.; Crociani, L.; Ganis, P.; Ceccon, A. *Chem. Eur. J.* **2007**, *13*, 1955-1968

UNIVERSITAT ROVIRA I VIRGILI
GOLD (I)-CATALYZED RETRO-CYCLOPROPANATION REACTION AND DEVELOPMENT OF TRINDANE-BASED
APPROACH TOWARD C60
Cesar Rogelio Solorio Alvarado
DL: T. 1714-2011

CHAPTER IV

The Trindane Approach to Polyarenes and Open Shell C60



UNIVERSITAT ROVIRA I VIRGILI
GOLD (I)-CATALYZED RETRO-CYCLOPROPANATION REACTION AND DEVELOPMENT OF TRINDANE-BASED
APPROACH TOWARD C60
Cesar Rogelio Solorio Alvarado
DL: T. 1714-2011

CHAPTER IV

Introduction

After the discovery and structural elucidation of C₆₀ in 1985 by vaporizing graphite with laser irradiation,²²⁵ its presence was demonstrated in the interstellar space.¹¹² Kroto, Smalley and Curl received the Nobel Prize in chemistry in 1996 for this contribution. The C₆₀ molecule is also called buckminsterfullerene or simply fullerene to recognize the architect Buckminster Fuller, whose geodesic designs have a geometrical relationship with C₆₀ (Figure 4.1).²²⁶

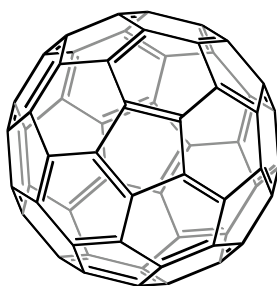

Figure 4.1. C₆₀, buckminsterfullerene or fullerene.

Fullerene has received great attention in the scientific community for its electronic,²²⁷ photophysical,²²⁸ and charge transfer²²⁹ properties in material

225 Kroto, H. W.; Heath, J. R.; O'Brien, S. C.; Curl, R. F.; Smalley, R. E. *Nature*, **1985**, *318*, 162-163.

226 Some patents of this geometric design: a) Geodesic dome, U.S.A. patent No. 2,682,235; b) Paper board dome, U.S.A. patent No. 2,881,717 and c) Polydome, U.S.A. patent No. 2,905,113.

227 Arena, F.; Bullo, F.; Conti, F.; Corvaja, C.; Maggini, F.; Prato, M.; Scorrano, G. *J. Am. Chem. Soc.* **1997**, *119*, 789-795.

228 Schuster, D. I.; Cheng, P.; Jarowski, P. D.; Guldi, D. M.; Luo, C.; Echegoyen, L.; Pyo, S.; Holzwarth, A. R.; Braslavsky, S. E.; Williams, R. E.; Klihm, G. *J. Am. Chem. Soc.* **2004**, *126*, 7257-72709.

229 Guldi, D. M.; Feng, L.; Radhakrishnan, S. G.; Nikawa, H.; Yamada, M.; Mizorogi, N.; Tsuchiya, T.; Akasaka, T.; Nagase, S.; Herranz, M.A.; Martín, N. *J. Am. Chem. Soc.* **2010**, *132*, 9078-9086.

science.²³⁰ Some approaches to synthesize fragments of the C₆₀ have been carried out (see introduction chapter), however a few rational total syntheses of C₆₀ have been reported.

The first rational synthesis was reported by Drewello and Scott, using laser-induced cyclodehydrogenation of a C₃-symmetric C₆₀H₃₀ (**124**) at 337 nm, to yield C₆₀ (Scheme 4.1).²³¹ Compound **124** had been prepared independently by a triple palladium-catalyzed arylation reaction¹⁴⁶ and its cyclodehydrogenation was demonstrated in the gas phase.²³²

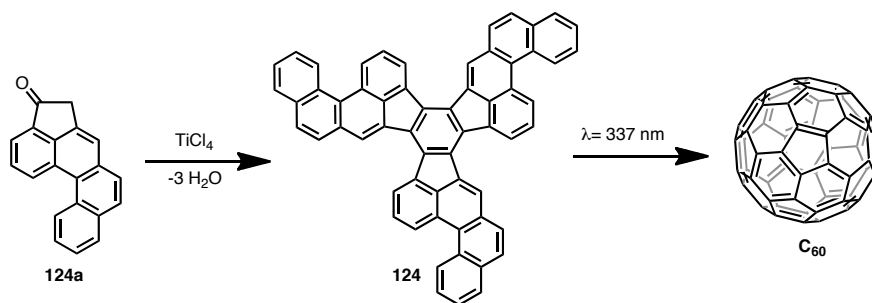

Scheme 4.1. Synthesis of C₆₀ by laser irradiation at 337 nm.

Another interesting cyclodehydrogenative synthesis was reported by Scott using flash vacuum pyrolysis (FVP) of the trichloro derivative **126**.²³³ Just 0.1-1% yield was achieved (Scheme 4.2).

230 a) Nierengarten, J. F.; Eckert, J. F.; Rio, Y.; Carreon, M. P.; Gallani, J. L.; Guillén D. *J. Am. Chem. Soc.* **2001**, *123*, 9743-9748. b) Fernáandez, G.; Pérez, E. M.; Sánchez, L.; Martín, N. *J. Am. Chem. Soc.* **2008**, *130*, 2410-2411.

231 Boorum, M. M.; Vasil'ev, Y. V.; Drewello, T.; Scott, L. T. *Science* **2001**, *294*, 828-831.

232 Otero, G.; Biddau, G.; Sánchez-Sánchez, C.; Caillard, R.; López, M. F.; Rogero, C.; Palomares, F. J.; Cabello, N.; Basanta, M. A.; Ortega, J.; Méndez, J.; Echavarren, A. M.; Pérez, R.; Gómez-Lor, B.; Martín-Gago, J. A. *Nature* **2008**, *454*, 865-868.

233 Boorum, M. M.; McMahon, B. J.; Hagen, S.; MacK, J.; Blanck, J.; Wegner, H.; Meijere, A. *Science* **2002**, *295*, 1500-1503.

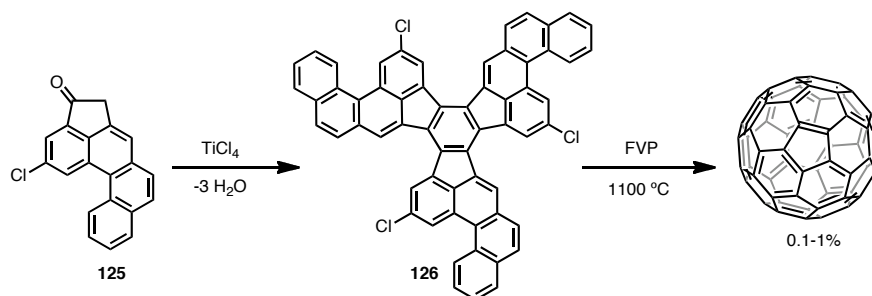

Scheme 4.2. Synthesis of C₆₀ by FVP at 1100 °C of **126**.

A more recent cyclodehydrogenative C₆₀ and C₅₇N₃ synthesis, from the truxene **127**¹⁴⁶ and triaza truxene **128**¹⁴⁷ was reported at 750 K over a Pt(111) surface.²³² Excellent yields of fullerene C₆₀ and triaza-fullerene C₅₇N₃ were isolated (Scheme 4.3). The intramolecular nature of this cyclodehydrogenation was confirmed independently.²³⁴

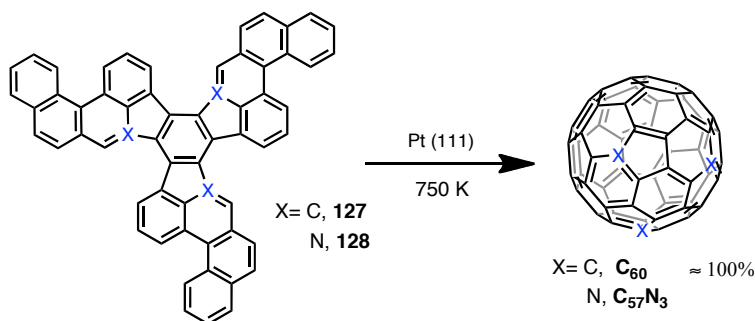

Scheme 4.3. Synthesis of fullerene and triaza-fullerene by cyclodehydrogenation over Pt(111) at 750 K.

One of the main inconveniences of the previously described syntheses is the insolubility of the starting materials which difficults their handling and characterization.

²³⁴ Amsharov, K.; Abdurakhmanova, N.; Stepanow, S.; Rauschenbach, S.; Cansen, M.; Kern, C. *Angew. Chem. Int. Ed.* **2010**, *49*, 9392-9396.

Considering the limitations of the reported examples on the synthesis of fullerene, we decided to explore new approaches toward its total synthesis. Analysis of the fullerene topology shows the trindane C₁₅ as a subunit present four times in the C₆₀. Since each molecule of trindane contains three pentagons, as a consequence all of the twelve pentagons in the C₆₀ would be present therefore C₆₀ system. (Scheme 4.4).

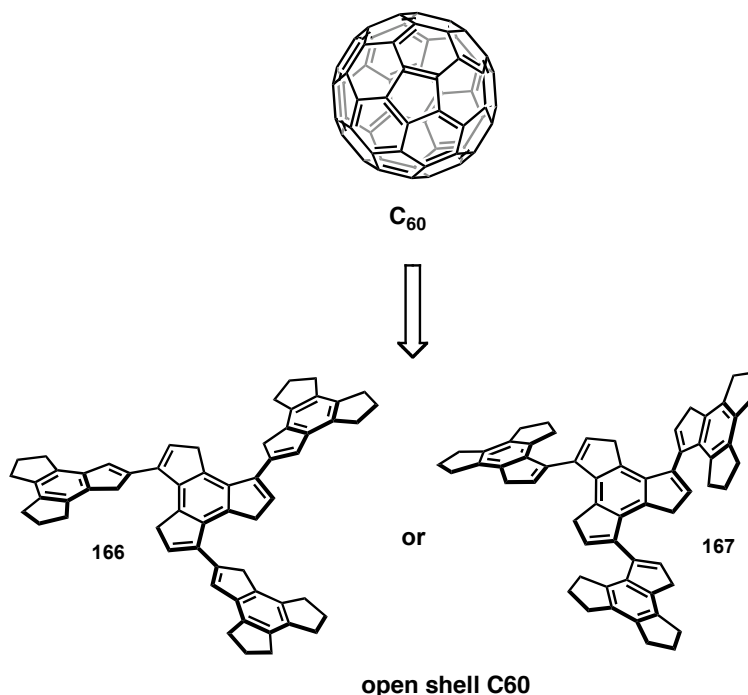

Scheme 4.4. Trinde-based open shell C₆₀.

Thus we envisioned that through a palladium-catalyzed cross coupling reaction of the properly functionalized trindene as electrophile and the adequate functionalization of another trindene as nucleophile, we could get access in one pot operation to an open C₆₀.

The complete retrosynthesis is following presented (Scheme 4.5).

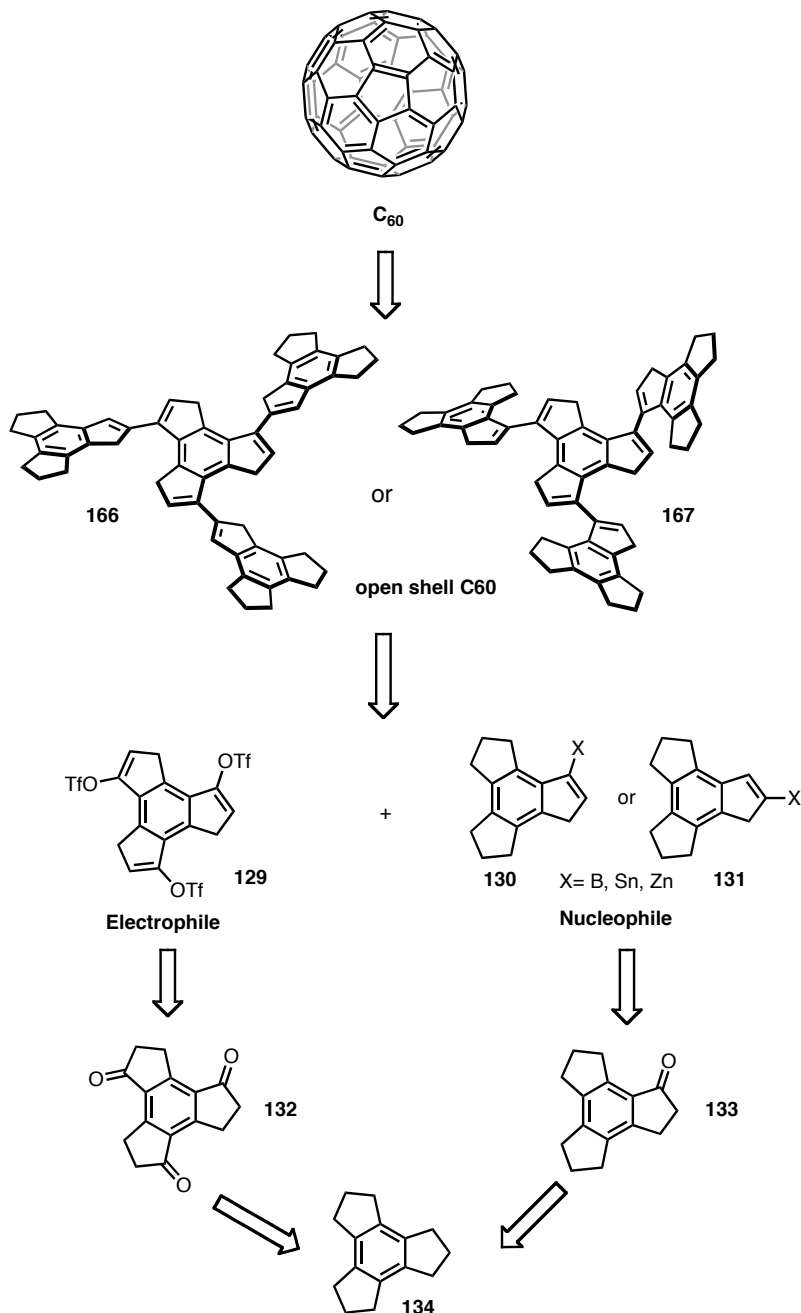

Scheme 4.5. Convergent trindane-base retrosynthesis of fullerene.

Results and discussion.

According to this proposal, the C_{3v} symmetry-based design shows a tris-triflate (**129**) as an optimal electrophile. Tris-triflate **129** could be prepared from tris-ketone **132**, while the nucleophile **130** or **131** was synthesized from ketone **133** (Scheme 4.5).

Trindane **134** is prepared in a multigram scale (160 g) with 33% yield by acid-catalyzed trimerization of cyclopentanone (**135**) (Scheme 4.6).²³⁵

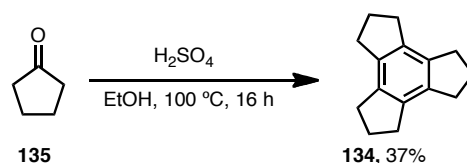

Scheme 4.6. Synthesis of trindane **134**.

The synthesis of trindanone **133** (8.5g scale) was achieved in 47% yield following the described procedure (Scheme 4.7).²³⁶

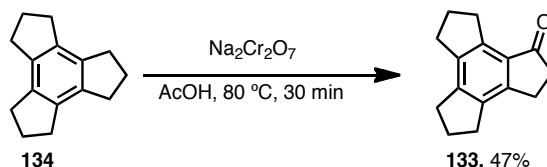

Scheme 4.7. Synthesis of trindanone **133**.

The synthesis of the tris-ketone **132** was carried out in 20% overall yield (1.7 g, scale) by a chromium(VI)-based oxidation procedure.²³⁷

235 Ranganathan, S.; Muraleedharan, K. M.; Bharadwaj, P.; Madhusudanan, K. P. *Chem. Commun.* **1998**, 239-240.

236 Ferrier, R. J.; Holden, S. G.; Gladkikh, O. *J. Chem. Soc., Perkin 1* **2000**, 20, 3505-3512.

237 a) Muzart, J.; Ajjou, A. N. *J. Molec. Cat.* **1991**, 66, 155-159. b) Muzart, J. *Tet. Lett.* **1987**, 28, 2131-2135.

Although the isolated yield is low, this transformation is an average 59% yield by each oxidation.

Table 4.1. Optimization and synthesis of tris-ketone **132**.

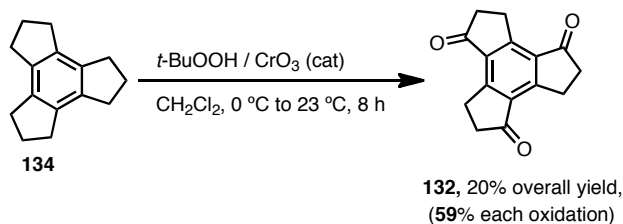

Entry	Trindane (g)	Oxidant System (equiv) / (mol%)	Time (h)	Yield (%)
1	0.1	CrO ₃ (3) / AcOH	15	0.8
2	0.1	CrO ₃ (3) / AcOH-Acetone	15	1.5 ^a
3	0.2	<i>t</i> -BuOOH (7.6) / CrO ₃ (5)	72	6
4	1	<i>t</i> -BuOOH (7.6) / CrO ₃ (5)	12	15
5	2	<i>t</i> -BuOOH (7.6) / CrO ₃ (5)	12	14
6	3	<i>t</i> -BuOOH (7.6) / CrO ₃ (5)	12	14
7	7	<i>t</i> -BuOOH (7.6) / CrO ₃ (5)	12	14
8	7	<i>t</i>-BuOOH (7.6) / CrO₃ (5)	8	20

a) Under these conditions scaling up to more than 500 mg of **134**, resulted in risk of explosion.

When the reactions were carried out in the presence of stoichiometric amounts of CrO₃, the isolated yields were low (Table 4.1, entries 1 and 2). The use of *t*-BuOOH as oxidant along with catalytic amounts of CrO₃ furnished the desired product **132** in slightly higher yields after three days (Table 4.1, entry 3). Surprisingly, reducing the reaction time to only 12 h, improved the isolated yield to 15% (Table 4.1, entry 4). Varying the amounts of trindane resulted in no

improvement (Table 4.1, entries 5-7). Finally, quenching the reaction after 8 h was key to achieve an overall yield of 20% (Table 4.1, entry 8). In addition the corresponding bis-ketone was isolated in 3% yield. Only by crude NMR has been observed some other minor byproducts.

The synthesis of tristrindene **137** was carried out from **132** by using the Luche reagent,²³⁸ to yield diastereomeric triol **136** in 93% as a 1:1 epimeric mixture. Dehydration of this benzylic triol was achieved by treatment with *p*-TsOH or Burgess reagent²³⁹ to give **137** and **138** (8 min reaction time) as a 10:1 mixture. A previous synthesis by Katz²⁴⁰ lead to **137** and **138** as a 1:1 mixture of regioisomers (Scheme 4.8).

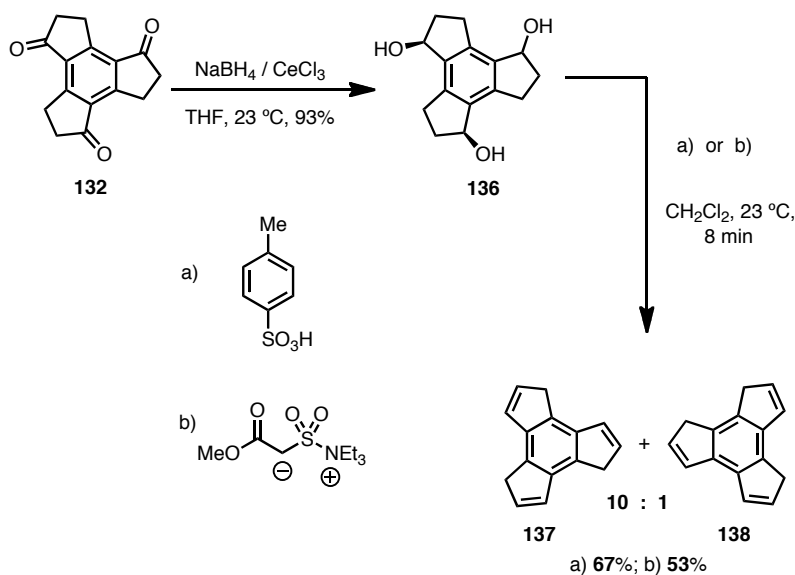

Scheme 4.8. Synthesis of symmetric tris-trindene.

238 Lannou, M. I.; Hélicon, F.; Namy, J. L. *Synlett*, **2007**, 2707-271.

239 Atkins, G. M.; Burgess, E. M. *J. Am. Chem. Soc.*, **1968**, *90*, 4744-4745.

240 Katz, J. T.; Slusarek, W. *J. Am. Chem. Soc.*, **1980**, *102*, 1058-1063.

The synthesis of the tris-triflate **129** was carried out in 91% (table 4.2).

Table 4.2. Synthesis of tris-triflate **129**.

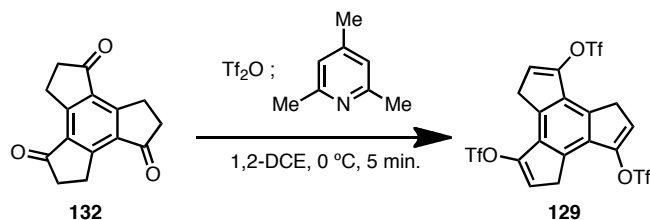

Entry	System	Solvent	Time (min)	Yield (%)
1	Tf_2O / DIPEA	THF	O. N.	--- ^a
2	Tf_2O	Py	O. N.	--- ^a
3	Tf_2O / HMDS	THF	30	--- ^b
4	Tf_2O / 2,6- <i>t</i> BuPy	1,2-DCE	5	53
5	Tf_2O / 2,4,6-Collidine	1,2-DCE	5	91

a) No reaction. *b*) Decomposition.

Formation of the enol triflate did not occur when THF or pyridine were used as solvents (entries 1 and 2). The use of sodium hexamethyldisilazide did not provide **129** (entry 3). The use of substituted pyridines as bases in DCE yielded the desired tris-triflate **129** in 91% yield (Table 4.2, entry 5). Aqueous work up with no further purification was crucial to obtain tris-triflate **129** in high yields and purity as a very stable compound. However, it was experimentally observed that when tris-triflate was kept in solution with soft bases such as Et_3N , the compound progressively decomposed in a short period of time.

We decided to test the Suzuki coupling²⁴¹ with phenyl boronic acid. Satisfactorily results were obtained using Pd(PPh₃)₄ as catalyst and Na₂CO₃ as base (Table 4.3).

Table 4.3. Optimization and synthesis of triphenyltrindene **139**.

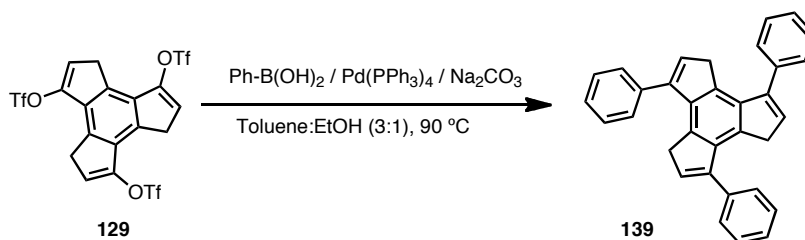

Entry	Ph-B(OH) ₂ (equiv)	Pd(PPh ₃) ₄ (mol%)	Temperature (°C)	Time (h)	Yield (%)
1	4.5	8	23	15	80
2	4.5	8	65	1	81
3	6	5	90	0.75	82
4	4.5	8	90	0.75	87

241 (a) Wang, Z. Q.; Feng, C. G.; Xu, M. H.; Lin, G. Q. *J. Am. Chem. Soc.* **2007**, *129*, 5336-5337. (b) Sellès, P.; Mueller, U. *Org. Lett.* **2004**, *6*, 277-279. (c) Stanislawski, P. C.; Willis, A. C.; Banwell, M. G. *Org. Lett.* **2006**, *8*, 2143-2146.

Under the conditions used a variety of aryltrindenes **139-144** were synthesized (Scheme 4.9).

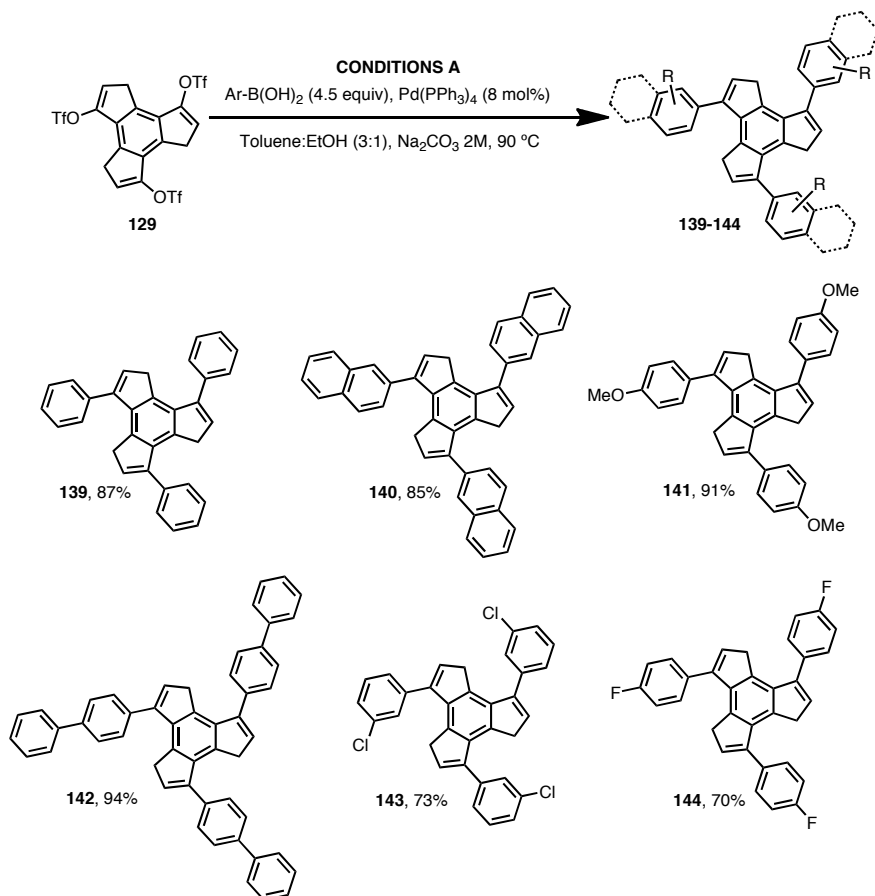

Scheme 4.9. Examples of the first C_{3v} -symmetric aryltrindenes **139-144**.

The aim was achieved with excellent yields in general. Different arylboronic acids could be used, consequently a diversity of derivatives ranging from electron-neutral (**139-140**) to electron-rich (**141-142**), and electron-poor aryltrindenes (**143-144**) were synthesized.

Looking for milder conditions other examples of this class of compounds were synthesized, decreasing the temperature at 70 °C or room temperature and using K_3PO_4 as base (Scheme 4.10).

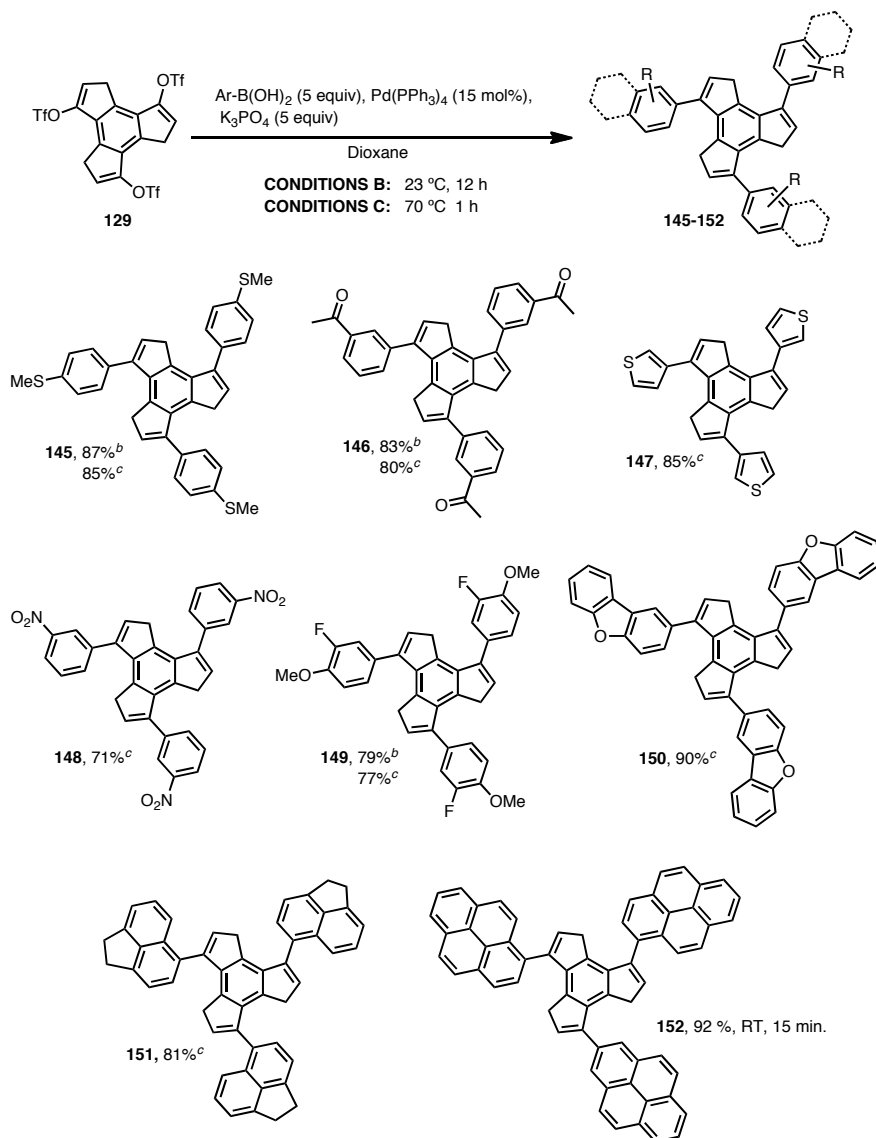

b) Conditions B were used. c) Conditions C were used.

Scheme 4.10. Additional examples of C_{3v} -symmetric aryltrindenones.

2-Indenylboronic acid **153**²⁴² synthesized from commercial indene was transformed into trifluoroborate salt²⁴³ 2-indene in 76% yield. On the other hand dioxaborole derivative **155** was prepared in 98% yield (Scheme 4.11).

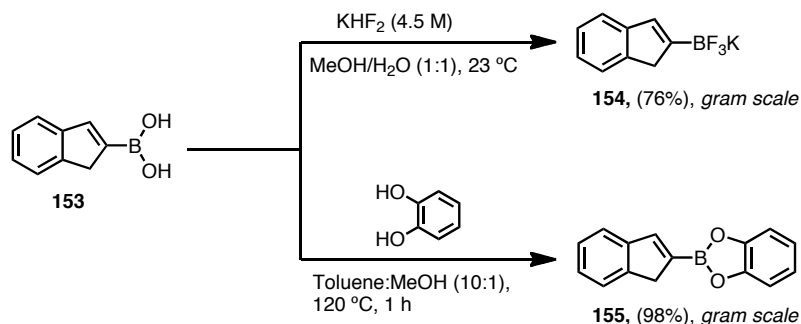

Scheme 4.11. Two different nucleophiles from 2-indene for Suzuki cross-coupling.

The synthesis of **156** was carried out in gram scale by coupling of tris(triflate) **129** with **154**²⁴³ or **155**²⁴⁴ in 60% and 63% yield respectively (Scheme 4.12).

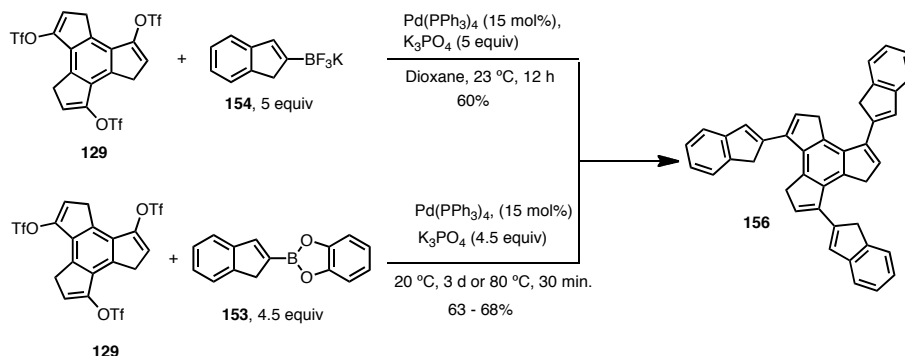

Scheme 4.12. Synthesis of model system **156**, by Suzuki reaction using two different indenyl derivatives.

242 Ijpeij, E. G.; Beijer, F. H.; Arts, H. J.; Newton, C.; de Vries, J. G.; Gruter, G. J. *J. Org. Chem.* **2002**, *67*, 169-176.

243 Ellis, N.; Molander, G. A. *Acc. Chem. Res.* **2007**, *40*, 275-286.

244 Oh-e, T.; Miyaura, N.; Suzuki, A. *J. Org. Chem.* **1993**, *58*, 2201-2208.

The synthesis of nucleophiles **130** and **131** was attempted from trindanone **133**. The synthesis of nucleophile derivatives **130a-130b** was unsuccessful under all the following reaction conditions (Scheme 4.13).

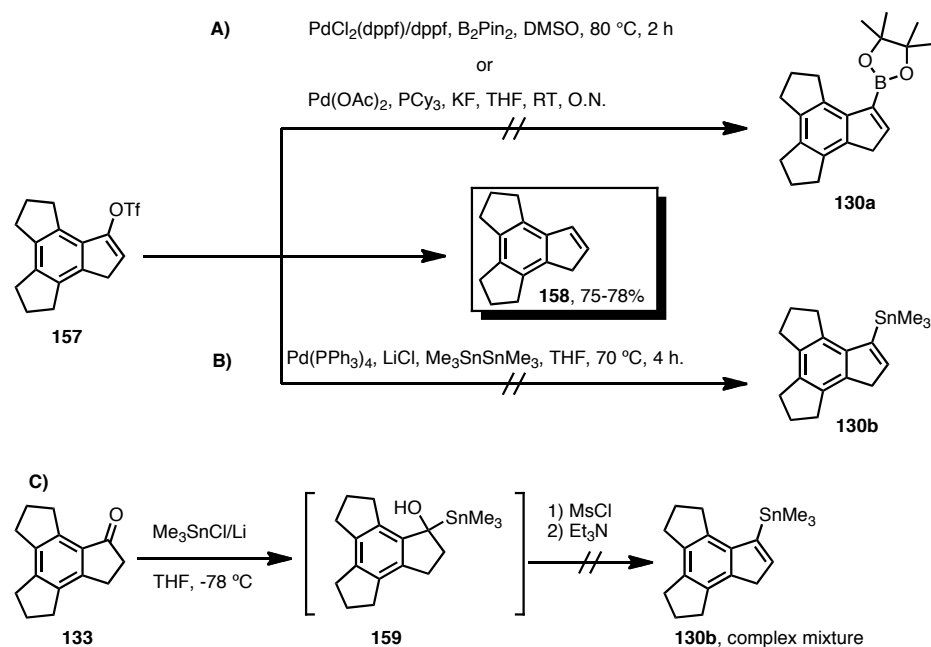

Scheme 4.13. Representative unsuccessful attempts in the synthesis of nucleophile **130b**.

Palladium-catalyzed coupling with B₂Pin₂²⁴⁵ or (Me₃Sn)₂²⁴⁶ (Scheme 4.13, A and B) failed to give **130a-b**. Shapiro²⁴⁷ reaction of the corresponding tosylhydrazone followed by reaction with (Me₃Sn)₂ gave only decomposition products. Additon²⁴⁸ of alkyllithium thin to **133** to form intermediate **159** followed by elimination also led to complex reaction mixtures (Scheme 4.13, C)

245 Ishiyama, T.; Itoh, Y.; Kitano, T.; Miyaura, N. *Tetrahedron* **1997**, *38*, 3447-3450.

246 Scott, W. J.; Stille, J. K. *J. Am. Chem. Soc.* **1986**, *108*, 3033-3040.

247 Shapiro, R. H.; Lipton, M. F.; Kolonko, K. J.; Buswell, R. L.; Capuano, L. A. *Tetrahedron Lett.* **1975**, *16*, 1811-1814.

248 Darwish, A.; Chong, M. *J. Org. Chem.* **2007**, *72*, 1507-1509.

The synthesis of the alternative nucleophile **131** was carried out by α -bromination of **133** to form **160** in 78% yield (3.9 g scale) followed by reduction with NaBH_4 (92%) to yield **161**. Final acid-catalyzed dehydration gave **162** in 89% yield (2.7 g scale) (Scheme 4.14).

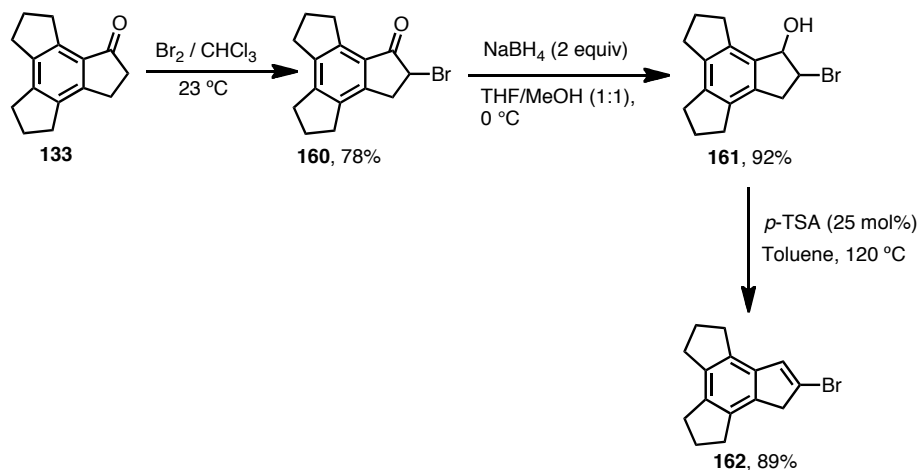

Scheme 4.14. Multigram scale synthesis of 2-bromotrindene **162**.

Coupling of 2-bromotrindene **163** with bis(catecholato)diboron²⁴⁵ was employed in the synthesis of nucleophile **164**, although attempts to purify the crude mixtures by either silica gel column chromatography, extraction or crystallization all resulted decomposition. However it was possible the identification by ^1H NMR (Scheme 4.15).

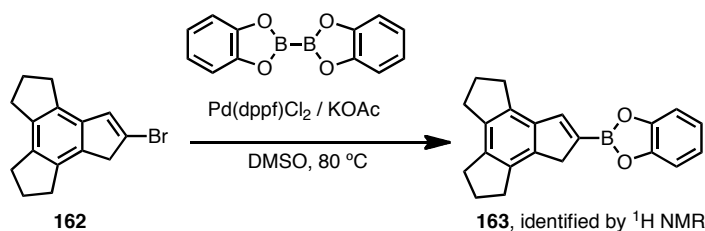

Scheme 4.15. Synthesis of nucleophile **164** and its identification by NMR.

The analogous pinacol derivative **164**, was initially obtained in low yield (22%, Scheme 4.16, A).²⁴⁹ **164** is itself a nucleophile for the cross-coupling. Unfortunately its poor reactivity and lability toward proto-deborylation in column conditions make it an inappropriate substrate (Scheme 4.16).

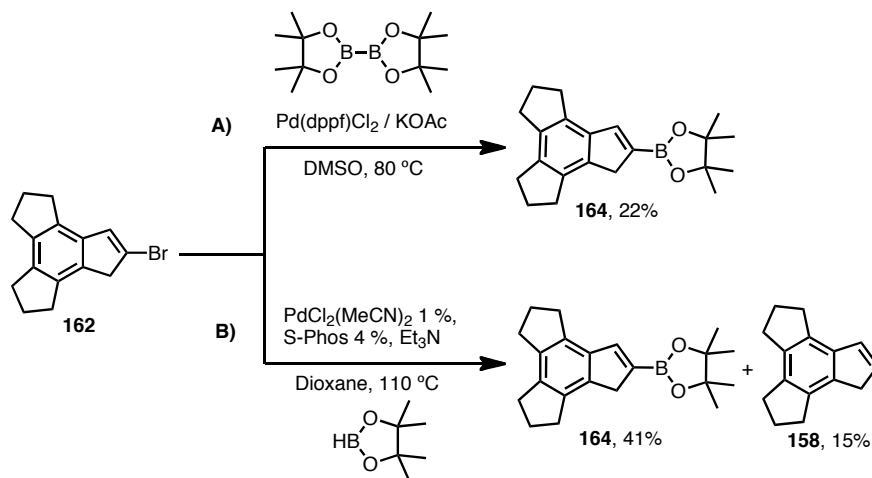

Scheme 4.16. Synthesis of nucleophile **165**.

Alternatively, the yield of **164** was improved by using a reaction protocol reported by Buchwald.²⁵⁰ Thus, compound **164** was successfully transformed to the more stable potassium trifluoroborate salt **165** in 73% overall yield (Scheme 4.17).²⁵¹ This two steps one-pot reaction procedure could be carried out in multigram scale.

249 Ishiyama, T.; Murata, M.; Miyaura, N. *J. Org. Chem.* **1995**, *60*, 7508-7510.

250 Billingsley, K. L.; Buchwald, S. L. *J. Org. Chem.* **2008**, *73*, 5589-5591.

251 Yuen, K. L.; Hutton, C. A. *Tetrahedron Lett* **2005**, *46*, 7899-7902.

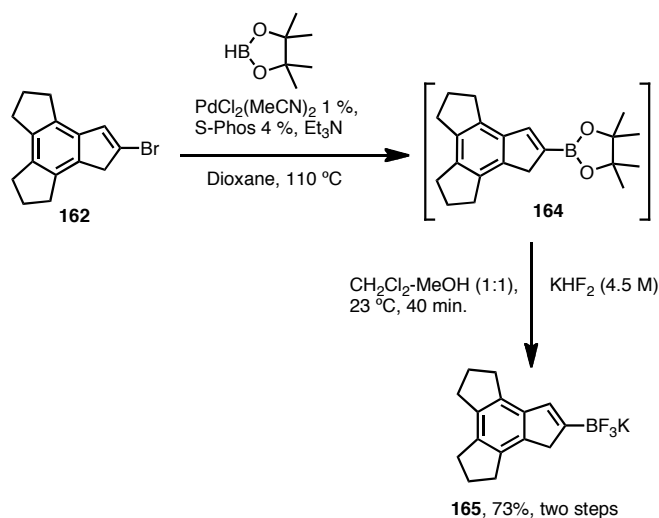

Scheme 4.17. Synthesis of 2-trindecyl potassium trifluoroborate **166**.

The assembly of the open C₆₀ was carried out by designed cross-coupling between **129** and **165** to **166** in 25% yield as a white solid. Even though overall yield was low, this represents a 63% average of each cross-coupling step (Scheme 4.18).

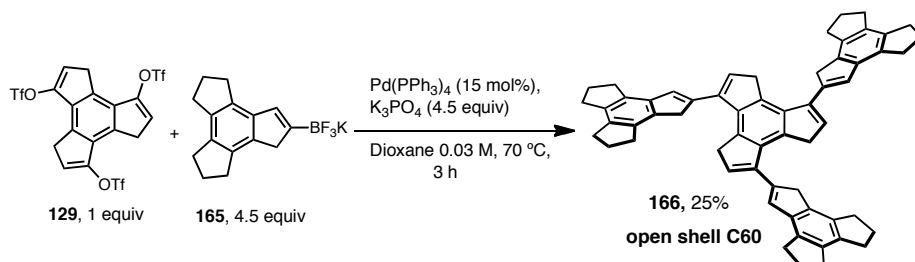

Scheme 4.18. Synthesis of proposed open C₆₀ by palladium-catalyzed Suzuki cross-coupling

Several additional efforts to improve it did not produce the desired result. Remarkably, the solubility of the synthesized open shell C₆₀ in CDCl_3 was excellent as expected. This adds an advantageous characteristic to the developed approach comparing with the described.

Structural confirmation of the **166** synthesized was done as usual by ^1H , ^{13}C (Scheme 4.18) and MALDI+ (Scheme 4.19).

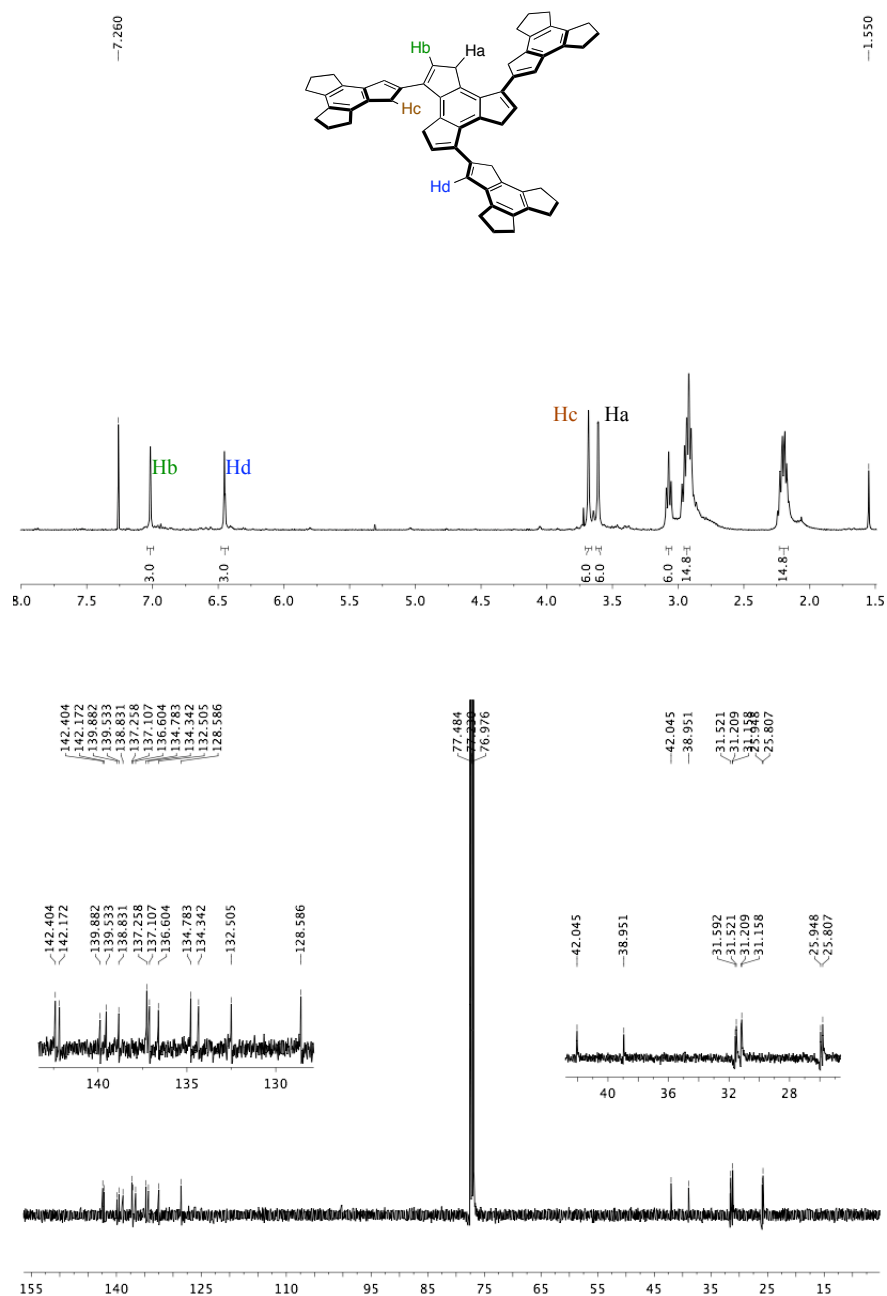

Scheme 4.18. Characterization of the open C₆₀ by ^1H and ^{13}C NMR.

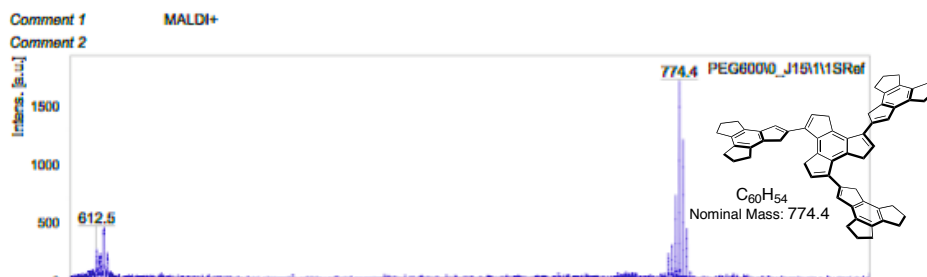

Scheme 4.19. Mass analysis of the synthesized open C_{60} by MALDI+.

Preliminary laser irradiation experiments on **166** were carried out. The formation of close hell C_{60} was not observed. Surprisingly in this experiment in addition to the molecular ion to 774, we observed peaks at $m/z = 774 + 16, +32 +64$ probably corresponding to benzylic oxidations of **166**.

We also tried the Diels-Alder cycloaddition of **156** with an excess of dimethyl acetylenedicarboxylate (DMAD) in refluxing toluene (Scheme 4.20).

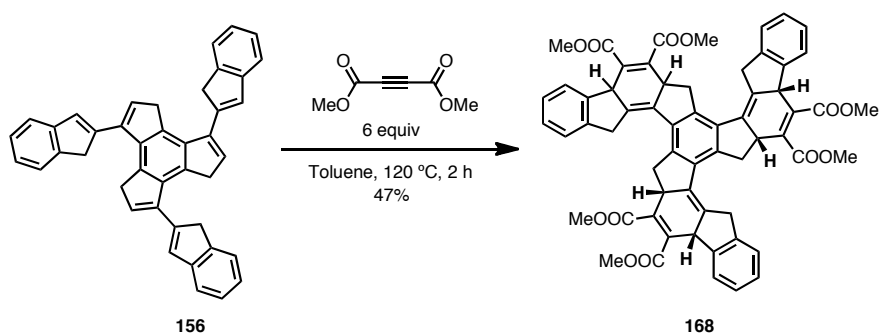

Scheme 4.20. Synthesis of **167** through a tris-Diels-Alder reaction

After 2 h heating at 120 °C, we isolated the tris-adduct **168** in 47% yield. Additionally, Diels-Alder reaction of **156** with tetracyanoethylene in toluene proceeded at room temperature to yield mono adduct **169** in 77% yield (Scheme 4.21).

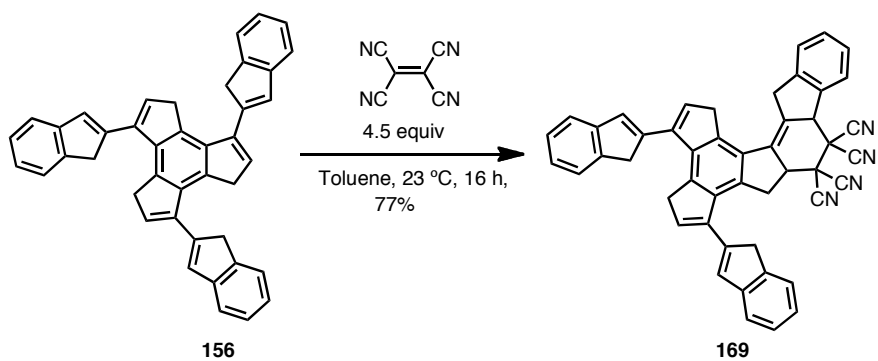
**Scheme 4.21.** Diels-Alder reaction of **156** with TCE.

Conclusions

- A convergent synthesis of an open shell C60 with all of the twelve pentagons present in C₆₀ was developed using trindane as the only building block.

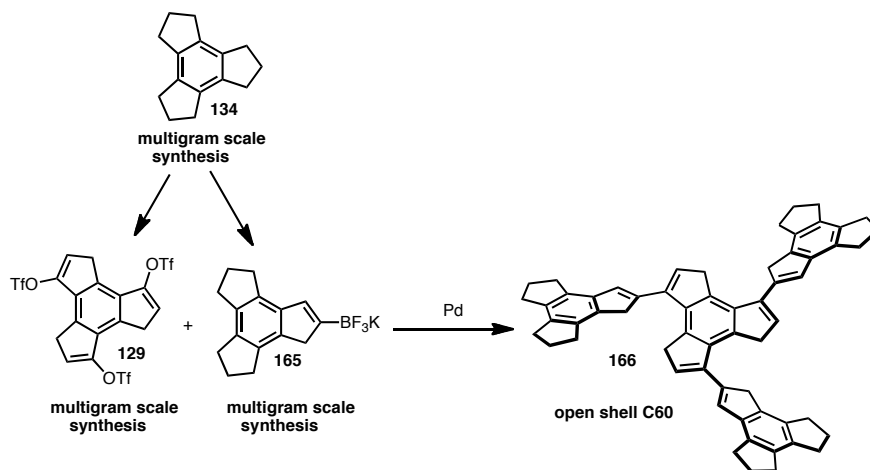

- We also developed a methodology for the synthesis of aryltrindenes by palladium catalyzed crosscoupling reactions.

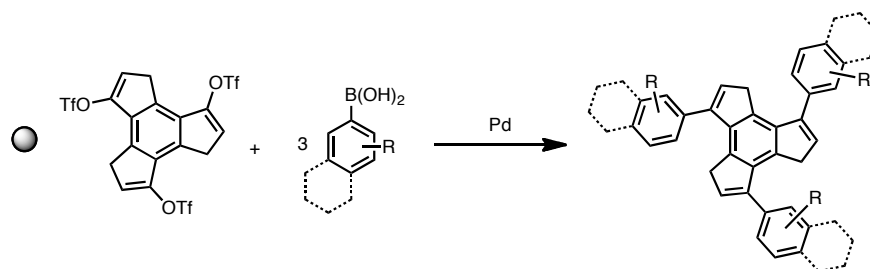

Experimental section

General Procedure A.

A screw-cap test-tube, equipped with a magnetic stir bar, was charged with triflate **129** (318.2 mg, 0.50 mmol) arylboronic acid (4.5 equiv) and Pd(PPh₃)₄ (46.2 mg, 0.04 mmol, 8 mol%). The vial was sealed with a teflon screw-cap, then evacuated and backfilled with argon. Toluene (5.55 mL, 0.09 M), ethanol (2.00 mL, 0.25 M) and Na₂CO₃ 2 M (2.25 mL, 9 equiv) were successively added and heated at 90 °C for 40 min. The reaction is diluted with 5 mL of EtOAc. The organic phase was extracted dried over magnesium sulfate and concentrated to dryness. The crude product such gotten was adsorbed in basic alumine and purified by flash chromatography using basic alumine as stationary phase.

General Procedure B.

A screw-cap test-tube, equipped with a magnetic stir bar, was charged with triflate **129** (318.2 mg, 0.50 mmol), arylboronic acid (5 equiv), K₃PO₄ (5 equiv) and Pd(PPh₃)₄ (86.6 mg, 0.75 mmol, 15 mol%). The vial was sealed with a teflon screw-cap, then evacuated and backfilled with argon. Deoxygenated dioxane (14.2 mL, 0.035 M) were added and stirred at room temperature overnight. The reaction is diluted with 8 mL of EtOAc. The organic phase was extracted dried over magnesium sulfate and concentrated to dryness. The crude product such gotten was adsorbed in basic alumine and purified by flash chromatography using basic alumine as stationary phase.

General Procedure C.

A screw-cap test-tube, equipped with a magnetic stir bar, was charged with triflate **129** (318.2 mg, 0.50 mmol), arylboronic acid (5 equiv), K₃PO₄ (5 equiv) and Pd(PPh₃)₄ (86.6 mg, 0.75 mmol, 15 mol%). The vial was sealed with a

teflon screw-cap, then evacuated and backfilled with argon. Deoxygenated dioxane (14.2 mL, 0.035 M) were added and stirred at 70 °C in a preheated oil bath for 1 h. The reaction is diluted with 8 mL of EtOAc. The organic phase was extracted dried over magnesium sulfate and concentrated to dryness. The crude product such gotten was adsorbed in basic alumine and purified by flash chromatography using basic alumine as stationary phase.

2,3,4,5,6,7,8,9-Octahydro-1*H*-cyclopenta[*e*]-as-indacene (134).¹

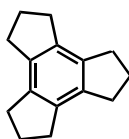

Gram scale synthesis. To a solution of cyclopentanone (640.0 mL, 7.2 mmol) in EtOH (360 mL) was added dropwise conc. H₂SO₄ (320 mL, 6.08 mmol). The mixture was heated under refluxing conditions for 15 h. After cooling to room temperature, the mixture was poured into ice, neutralized with NaHCO₃, and extracted with CH₂Cl₂ (3x 500 mL). The extracts were washed with water, dried over MgSO₄, and purified by flash chromatography column (hexane), to give a white solid (160.08 g, 33%) corresponding to the desired compound. m.p. 92 °C; R_f = 0.5 (hexane).

¹H NMR (CDCl₃, 400 MHz) δ 2.89 (t, *J* = 7.3 Hz, 12 H), 2,17 (q, *J* = 7.3 Hz, 6H).

¹³C NMR (CDCl₃, 100 MHz) δ 137.7, 31.2, 25.5. The spectroscopic data match with those reported in the literature.

2,3,4,5,6,7,8,9-Octahydro-1*H*-cyclopenta[*e*]-as-indacen-1-one (133).²

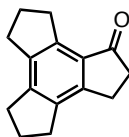

Gram scale Synthesis. Trindane **134** (17.00 g, 85.73 mmol) was dissolved in glacial acetic acid (180 mL) and heated to 80 °C, then sodium dichromate

dihydrate (31.45 g, 103.02 mmol) was added in one portion. The mixture was stirred to this temperature by 30 min. after which was partitioned between ether and water, washed with NaOH 2 M and dried over magnesium sulfate. The crude product was purified by flash chromatography (AcOEt / Hex 5%), to give a white solid (8.50 g, 47%) corresponding to the desired compound. mp. 114–115.5 °C; $R_f = 0.52$ (AcOEt / Hex 5%).

^1H NMR (CDCl_3 , 400 MHz) δ 3.21 (t, $J = 7.4$ Hz, 2H), 2.97 (t, $J = 5.6$ Hz, 2H), 2.88 (t, $J = 7.4$ Hz, 4H), 2.79 (t, $J = 7.4$ Hz, 2H), 2.65 (t, $J = 5.6$ Hz, 2H), 2.17 (q, $J = 7.4$ Hz, 2H), 2.14 (q, $J = 7.4$ Hz, 2H).

^{13}C NMR (CDCl_3 , 100 MHz) δ 207.6, 149.5, 147.0, 141.4, 140.0, 139.2, 131.5, 36.9, 32.0, 31.0, 30.4, 30.0, 25.5, 25.2, 24.6. The spectroscopic data match with those reported in the literature.

2,3,5,6,8,9-Hexahydro-1*H*-cyclopenta[*e*]-as-indacene-1,4,7-trione (132).

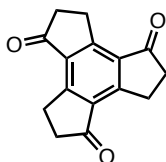

Gram scale synthesis. CrO_3 (700 mg, 7.00 mmol) were suspended in 210 mL of CH_2Cl_2 , and cooled to 0 °C with an ice bath. *t*-BuOOH (70% w/w) (105 mL, 735.00 mmol) was added to this temperature and stirred by 3 min, then trindane **134** (7.00 g, 35,30 mmol) was added in one portion and stirred overnight without ice bath. The reaction was stopped by adding 150 mL of (10%) $\text{Na}_2\text{S}_2\text{O}_3$ and stirred by 3 h. The reaction mixture was extracted with THF (3x100 mL), the organic phases were collected and evaporated to dryness. The crude such gotten was purified by flash chromatography (AcOEt / Hex 50%), to yield a white solid (1.73 g, 20%) corresponding to the desired ketone.. $R_f = 0.31$ (AcOEt / Hex 40%). m.p. > 210 °C.

^1H NMR (CDCl_3 , 300 MHz) δ 3.57 (ddd, $J = 5.7, 3.6, 2.6$ Hz, 6H), 2.83 (ddd, $J = 5.7, 3.5, 2.6$ Hz, 6H).

^{13}C NMR (CDCl_3 , 100 MHz) δ 205.5, 160.5, 134.1, 36.42, 25.68. HRMS-ESI
calc. for $\text{C}_{15}\text{H}_{12}\text{O}_3$ ($M + \text{Na}$) $^+$: 263.0670 found 263.0684.

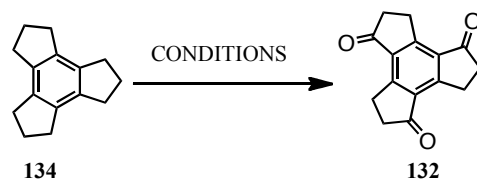
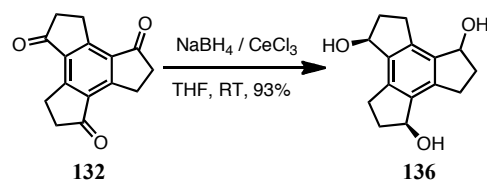

Table 1. Optimization for the synthesis of trione **132**.

TRINDANE	OXIDANT SYSTEM	TIME (h)	YIELD (%)
100 mg	CrO_3 (3 equiv)/ AcOH	15	0.8
100 mg	CrO_3 (3 equiv)/ AcOH-Acetone	15	1.5
200 mg	<i>t</i> -BuOOH (7.6 equiv) / CrO_3 (5 mol%)	72	6
1 g	<i>t</i> -BuOOH (7.6 equiv) / CrO_3 (5 mol%)	12	15
2 g	<i>t</i> -BuOOH (7.6 equiv) / CrO_3 (5 mol%)	12	14
3 g	<i>t</i> -BuOOH (7.6 equiv) / CrO_3 (5 mol%)	12	14
7 g	<i>t</i> -BuOOH (7.6 equiv) / CrO_3 (5 mol%)	12	14
7 g	<i>t</i>-BuOOH (7.6 equiv) / CrO_3 (5 mol%)	8	20



(1*R*^{*},4*R*^{*})-2,3,4,5,6,7,8,9-Octahydro-1*H*-cyclopenta[*e*]-as-indacene-1,4,7-triol (136). In a 20 mL two necks, dry round bottom flask, was placed trindanetrione **132** (120.1 mg, 0.50 mmol), anhydrous cerium trichloride (431.3 mg, 1.75 mmol) and 4 mL of dry THF. The mixture is stirred to room temperature for 10 min. before to add sodium borohydride (132.4 mg, 1.75 mmol). An exothermic

reaction is observed. After 15 min. the reaction is quenched with aqueous NH₄Cl and extracted with ethyl acetate (3x10 mL). The organic phases are dried over magnesium sulfate, filtered and the solvent removed under reduced pressure to yield a white solid (114.5 mg, 93%) which correspond to the desired triol. m.p. 152 – 153.5 °C.

¹H NMR (MeOD, 400 MHz) δ 5.21-5.11 (m, 4H), 3.31-3.20 (m, 2H), 3.10-2.96 (m, 4H), 2.82-2.70 (m, 2H), 2.50-2.34 (m, 4H), 2.09-1.95 (m, 4H).

¹³C NMR (MeOD, 100 MHz) δ 142.05, 142.0, 141.96, 141.94, 140.5, 140.4, 140.39(x2), 75.8, 75.78, 75.6, 75.55, 36.90, 36.86(x2), 36.84, 28.8(x2), 28.7, 28.69. HRMS-ESI calcd for C₁₈H₁₅O₃ (*M*+Na)⁺: calc. for 269.1163 found 269.1154.

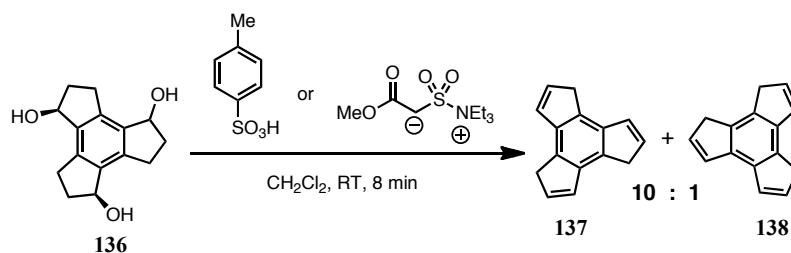

4,7-Dihydro-1*H*-cyclopenta[*e*]-as-indacene **137 and 4,9-dihydro-1*H*-cyclopenta[*e*]-as-indacene (**138**).** In a 20 mL two necks, dry round bottom flask, were placed triol (24.6 mg, 0.1 mmol), *p*-TSA*H₂O (28.6 mg, 0.15 mmol) or Burgess reagent (83.4 mg, 0.35 mmol) and 2 mL of dichloromethane. The reaction is stirred for 8 min. and immediately filtered through basic alumina. The solvent is evaporated to dryness and yields a 9:1 mixture of regioisomers. (16.5 mg, 67% combined yield, from *p*-TSA) or (13.1 mg, 53% combined yield, from Burgess reagent) of a white solid, which correspond to the desired compound. mp. > 230 °C (change of color).

Signals for main regioisomer **137**. ¹H NMR (CDCl₃, 400 MHz) δ 7.05 (dt, *J* = 5.6, 2.0 Hz, 1H), 6.62 (dt, *J* = 5.6, 2.0 Hz, 1H), 3.56 (t, *J* = 2.0 Hz, 2H).

¹³C NMR (CDCl₃, 100 MHz) δ 138.9, 133.9, 132.7, 130.5, 37.7. HRMS-APCI calcd for C₁₅H₁₆ (*M*+H)⁺: 193.1017; found 193.1031.

Selected signals for minor regioisomer **138**. ^1H NMR (CDCl_3 , 400 MHz) δ 7.13 (tt, $J = 6.0, 2.4$ Hz, 1H), 7.02 (tt, $J = 6.0, 2.4$ Hz, 1H), 3.52 (t, $J = 2.4$ Hz, 1H), 3.47 (t, $J = 2.4$ Hz, 1H), 3.45 (t, $J = 2.4$ Hz, 1H).

4,7-Dihydro-1H-cyclopenta[e]-as-indacene-3,6,9-triyltris(trifluoromethanesulfonate) (129).

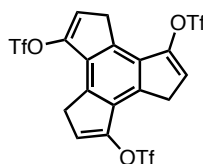

Gram scale synthesis. Trindanetrione **132** (1.5 g, 6.24 mmol) was dissolved in 40 mL of 1,2-dichloroethane and cooled to 0 °C. At this temperature triflic anhydride (3.47 mL, 20.60 mmol) were added dropwise followed by 2,4,6-collidine (2.72 mL, 20.60 mmol). The mixture is stirred to this temperature by 5 min. The reaction is diluted with 150 mL of 1,2-dichloroethane and washed with water (3x150 mL). The organic phase was separated and dried over magnesium sulfate. This organic phase was evaporated *without heating* to dryness to yield a brown solid (3.61 g, 91%) corresponding to pure triflate. m.p. 137.5–139 °C.

^1H NMR (CDCl_3 , 400 MHz) δ 6.53 (t, $J = 2.4$ Hz, 3H), 3.80 (d, $J = 2.4$ Hz, 6H). ^{13}C NMR (CDCl_3 , 100 MHz) δ 147.7, 133.0, 131.0, 119.3, 33.7. HRMS-ESI calcd for $\text{C}_{18}\text{H}_9\text{F}_9\text{O}_9\text{S}_3$ ($M\text{-H}$) $^+$: 634.9171; found: 634.9163.

3,6,9-Triphenyl-4,7-dihydro-1H-cyclopenta[e]-as-indacene (139).

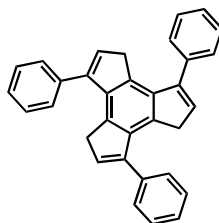

This compound was prepared in 87% yield according to the general procedure **A**, starting from triflate **129** and phenylboronic acid. White solid. m.p. 210–211 °C.

^1H NMR (CDCl_3 , 400 MHz) δ 7.48-7.40 (m, 15 H), 6.33 (t, $J = 2.0$ Hz, 3H), 3.20 (d, $J = 2.0$ Hz, 6H).

^{13}C NMR (CDCl_3 , 100 MHz) δ 145.8, 140.0, 138.4, 134.0, 132.4, 129.1, 128.2, 127.5, 38.1. HRMS-APCI calcd for $\text{C}_{33}\text{H}_{24}$ ($M\text{-H}$) $^+$: 419.1800; found 419.1803.

3,6,9-Tri(naphthalen-2-yl)-4,7-dihydro-1H-cyclopenta[e]-as-indacene (140).

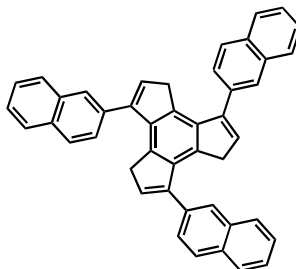

This compound was prepared in 85% yield according to the general procedure A, starting from triflate **129** and naphthalen-2-ylboronic acid. White solid. m.p. 276–278 °C.

^1H NMR (CDCl_3 , 400 MHz) δ 7.95-7.88 (m, 12H), 7.63 (dd, $J = 7.2, 1.3$ Hz, 3H), 7.55 – 7.53 (m, 6H), 6.38 (t, $J = 2.0$ Hz, 3H), 3.26 (d, $J = 2.0$ Hz, 6H).

^{13}C NMR (CDCl_3 , 100 MHz) δ 145.7, 140.1, 135.9, 134.2, 133.4, 132.9, 132.8, 128.2, 128.0, 127.7, 127.6, 127.5, 126.4, 126.1, 38.4. HRMS-APCI calcd for $\text{C}_{45}\text{H}_{30}$ ($M\text{-H}$) $^+$: 569.2269; found 569.2267.

3,6,9-Tris(4-methoxyphenyl)-4,7-dihydro-1H-cyclopenta[e]-as-indacene (141)

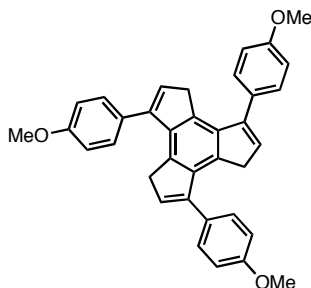

This compound was prepared in 91% yield according to the general procedure **A**, starting from tristriflate **129** and (4-methoxyphenyl)boronic acid. Beige solid. m.p. 219-220 °C.

^1H NMR (CDCl_3 , 400 MHz) δ 7.37 (d, $J = 8.4$ Hz, 6H), 6.98 (d, $J = 8.4$ Hz, 6H), 6.29 (t, $J = 1.6$ Hz, 3H), 3.89 (s, 9H), 3.20 (d, $J = 1.6$ Hz, 6H).

^{13}C NMR (CDCl_3 , 100 MHz) δ 159.2, 145.3, 140.2, 133.9, 132.1, 130.8, 130.2, 113.6, 55.5, 38.1. HRMS-APCI calcd for $\text{C}_{36}\text{H}_{30}\text{O}_3$ ($M\text{-H}$) $^+$: 509.2117; found 509.2121.

3,6,9-Tri(biphenyl-4-yl)-4,7-dihydro-1H-cyclopenta[e]-as-indacene (142).

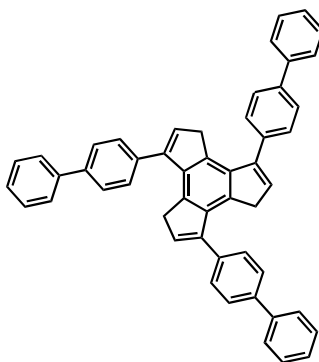

This compound was prepared in 94% yield according to the general procedure **A**, starting from tristriflate **129** and [1,1'-biphenyl]-4-ylboronic acid. White solid. m.p. 245–246 °C.

^1H NMR (CDCl_3 , 400 MHz) δ 7.70 (dd, $J = 8.4$ Hz, 12H), 7.56 (d, $J = 8.0$ Hz, 6H), 7.49 (t, $J = 8.0$ Hz, 6H), 7.39 (t, $J = 6.0$ Hz, 3H), 6.40 (t, $J = 4.0$ Hz, 3H), 3.31 (d, $J = 4.0$ Hz, 6H).

^{13}C NMR (CDCl_3 , 100 MHz) δ 145.5, 141.1, 140.4, 140.0, 137.3, 134.1, 132.7, 129.5, 129.0, 127.5, 127.3, 126.9, 38.4. HRMS-APCI calcd for $\text{C}_{51}\text{H}_{36}$ ($M\text{-H}$) $^+$: 647.2739; found 647.2739.

3,6,9-Tris(3-chlorophenyl)-4,7-dihydro-1*H*-cyclopenta[*e*]-as-indacene (143).

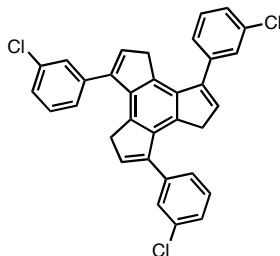

This compound was prepared in 73% yield according to the general procedure **A**, starting from tris(triflate) **129** and (3-chlorophenyl)boronic acid. Amber oil.

^1H NMR (CDCl_3 , 400 MHz) δ 7.47 (s, 3H), 7.41 – 7.34 (m, 9H), 6.38 (bs, 3H), 3.22 (bs, 6H).

^{13}C NMR (CDCl_3 , 100 MHz) δ 144.5, 140.0, 139.6, 134.1, 133.9, 133.2, 129.5, 129.1, 127.8, 127.2, 38.2. HRMS-APCI calcd for $\text{C}_{33}\text{H}_{21}\text{Cl}_3$ ($M+\text{H}$) $^+$: 523.0787; found 523.0785.

3,6,9-Tris(4-fluorophenyl)-4,7-dihydro-1*H*-cyclopenta[*e*]-as-indacene (144).

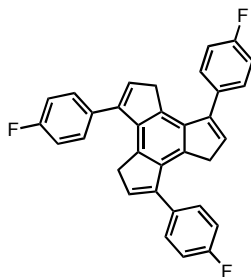

This compound was prepared in 70% yield according to the general procedure **A**, starting from tris(triflate) **129** and (4-fluorophenyl)boronic acid. Beige solid. m.p. 174–176 °C.

^1H NMR (CDCl_3 , 400 MHz) δ 7.41 (dd, J = 8.8, 3.2 Hz, 6H), 7.14 (dd, J = 8.8, 3.2 Hz, 6H), 6.33 (t, J = 1.6 Hz, 3H), 3.17 (d, J = 1.6 Hz, 6H).

^{13}C NMR (CDCl_3 , 100 MHz) δ 162.6 (d, J = 244 Hz), 144.8, 139.9, 134.1 (d, J = 4 Hz), 133.8, 132.7, 130.6 (d, J = 8 Hz), 115.1 (d, J = 21 Hz), 38.1. HRMS-APCI calcd for $\text{C}_{33}\text{H}_{21}\text{F}_3$ ($M-\text{H}$) $^+$: 473.1517; found 473.1510.

3,6,9-Tris(4-(methylthio)phenyl)-4,7-dihydro-1*H*-cyclopenta[*e*]-as-indacene (145).

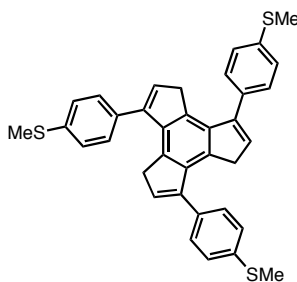

This compound was prepared in 87% yield according to the general procedure **B**, and 85% yield according to the general procedure **C** starting from triflate **129** and (4-(methylthio)phenyl)boronic acid. Brown solid. m.p. 226–227 °C.

^1H NMR (CDCl_3 , 400 MHz) δ 7.37 (d, $J = 8.6$ Hz, 6H), 7.32 (d, $J = 8.3$ Hz, 6H), 6.31 (t, $J = 2.0$ Hz, 3H), 3.21 (d, $J = 2.0$ Hz, 6H), 2.55 (s, 9H).

^{13}C NMR (CDCl_3 , 100 MHz) δ 145.2, 139.9, 137.7, 135.1, 134.0, 132.6, 129.5, 126.3, 38.3, 16.1. HRMS-ESI calcd for $\text{C}_{36}\text{H}_{30}\text{S}_3$ ($M+\text{H}$) $^+$: 559.1564; found 559.1554.

1,1',1''-(3,3',3''-(4,7-Dihydro-1*H*-cyclopenta[*e*]-as-indacene-3,6,9-(triyl)tris-(benzene-3,1-diyl))triethanone (146).

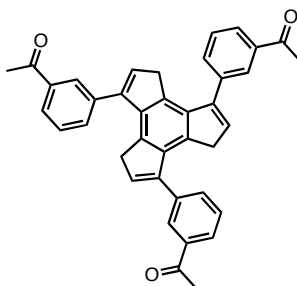

This compound was prepared in 83% yield according to the general procedure **B**, and 80% yield according to the general procedure **C** starting from triflate **129** and (3-acetylphenyl)boronic acid. Beige solid. m.p. 102–104 °C.

^1H NMR (CDCl_3 , 400 MHz) δ 8.06 (t, $J = 1.6$ Hz, 3H), 8.01 (dt, $J = 7.6$, 1.6 Hz, 3H), 7.66 (dt, $J = 7.6$, 1.6 Hz, 3H), 7.56 (t, $J = 7.6$ Hz, 3H), 6.37 (t, $J = 2.0$ Hz, 3H), 3.17 (d, $J = 2.0$ Hz, 6H), 2.65 (s, 9H).

^{13}C NMR (CDCl_3 , 100 MHz) δ 198.2, 144.8, 139.7, 138.6, 137.1, 133.9, 133.6, 133.2, 128.9, 128.6, 127.6, 38.3, 27.0. HRMS-ESI calcd for $\text{C}_{39}\text{H}_{30}\text{O}_3$ ($M+\text{Na}$) $^+$: 569.2093; found 569.2094.

3,6,9-Tri(thiophen-3-yl)-4,7-dihydro-1H-cyclopenta[e]-as-indacene (147).

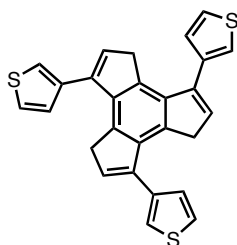

This compound was prepared in 85% yield according to the general procedure C, starting from triflate **129** and thiophen-3-ylboronic acid. Brown dark solid. m.p. 210–212 °C.

^1H NMR (CDCl_3 , 400 MHz) δ 7.41 (dd, $J = 5.1$, 3.0 Hz, 3H), 7.29 (dd, $J = 3.1$, 1.2 Hz, 3H), 7.20 (dd, $J = 3.1$, 1.2 Hz, 3H), 6.41 (t, $J = 2.0$ Hz, 3H), 3.26 (d, $J = 2.0$ Hz, 6H).

^{13}C NMR (CDCl_3 , 100 MHz) δ 140.5, 139.9, 138.4, 133.7, 133.0, 129.2, 125.2, 122.9, 37.7. HRMS-ESI calcd for $\text{C}_{27}\text{H}_{18}\text{S}_3$ ($M+\text{H}$) $^+$: 439.0649; found 439.0649.

3,6,9-Tris(3-nitrophenyl)-4,7-dihydro-1H-cyclopenta[e]-as-indacene (148).

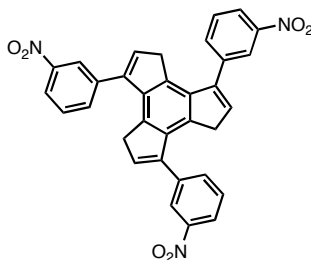

This compound was prepared in 71% yield according to the general procedure **C**, starting from triflate **129** and (3-nitrophenyl)boronic acid. Yellow solid. m.p. 118-119 °C.

^1H NMR (CDCl_3 , 400 MHz) δ 8.39 (t, $J = 2.0$ Hz, 3H), 8.35-8.32 (m, 3H), 7.85 (dt, $J = 1.6, 7.6$ Hz, 3H), 7.69 (t, $J = 8.0$ Hz, 3H), 6.51 (t, $J = 2.0$ Hz, 3H), 3.26 (d, $J = 2.0$ Hz, 6H).

^{13}C NMR (CDCl_3 , 100 MHz) δ 148.3, 143.6, 139.6, 139.4, 135.0, 134.3, 133.9, 129.4, 123.9, 122.8, 38.4. HRMS-APCI calcd for $\text{C}_{33}\text{H}_{21}\text{N}_3\text{O}_6$ ($M\text{-H}$) $^+$: 554.1352; found 554.1354.

3,6,9-Tris(3-fluoro-4-methoxyphenyl)-4,7-dihydro-1*H*-cyclopenta[*e*]-as-indacene (149).

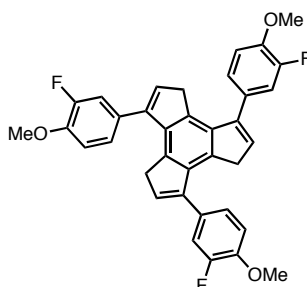

This compound was prepared in 79% yield according to the general procedure **B**, and 77% yield according to the general procedure **C** starting from triflate **129** and (3-fluoro-4-methoxyphenyl)boronic acid. Yellow solid. m.p. 104.5-106 °C.

^1H NMR (CDCl_3 , 400 MHz) δ 7.19-7.13 (m, 6H), 7.03 (t, $J = 8.4$ Hz, 3H), 6.32 (t, $J = 2.0$ Hz, 3H), 3.97 (s, 9H), 3.23 (d, $J = 2.0$ Hz, 6H).

^{13}C NMR (CDCl_3 , 100 MHz) δ 152.1 (d, $J = 244$ Hz), 147.2 (d, $J = 11$ Hz), 144.4, 139.8, 133.8, 132.7, 131.2 (d, $J = 7$ Hz), 124.8 (d, $J = 3$ Hz), 116.9 (d, $J = 18$ Hz), 113.1, 56.6, 38.1. HRMS-APCI calcd for $\text{C}_{36}\text{H}_{27}\text{F}_3\text{O}_3$ ($M\text{-H}$) $^+$: 563.1834; found 563.1827.

3,6,9-Tris(dibenzo[*b,d*]furan-2-yl)-4,7-dihydro-1*H*-cyclopenta[*e*]-as-indacene (150).

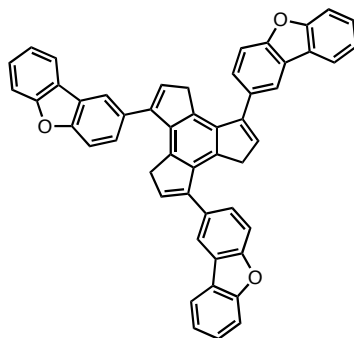

This compound was prepared in 90% yield according to the general procedure C, starting from triflate **129** and dibenzo[*b,d*]furan-4-ylboronic acid. Beige solid. m.p. 192–194 °C.

^1H NMR (CDCl_3 , 400 MHz) δ 8.04 (dt, $J = 7.2, 2.0$ Hz, 6H), 7.56 (d, $J = 8.4$ Hz, 3H), 7.49-7.37 (m, 12H), 6.40 (t, $J = 2.0$ Hz, 3H), 3.06 (d, $J = 2.0$ Hz, 6H).

^{13}C NMR (CDCl_3 , 100 MHz) δ 156.4, 154.4, 140.2, 140.0, 134.1, 134.0, 128.5, 128.2, 124.6, 124.4, 123.1, 123.0, 122.9, 120.9, 120.1, 112.3, 37.2. HRMS-APCI calcd for $\text{C}_{51}\text{H}_{30}\text{O}_3$ ($M\text{-H}$) $^+$: 689.2117; found 689.2102.

3,6,9-Tris(1,2-dihydroacenaphthylen-5-yl)-4,7-dihydro-1*H*-cyclopenta[*e*]-indacene (151).

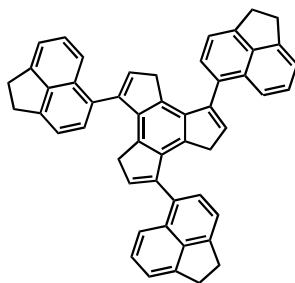

This compound was prepared in 81% yield according to the general procedure C, starting from triflate **129** and (1,2-dihydroacenaphthylen-5-yl)boronic acid. Brown solid. m.p. 212–214 °C.

^1H NMR (CDCl_3 , 400 MHz) δ 7.57-7.28 (m, 15H), 6.25 (t, $J = 2.0$ Hz, 3H), 3.54-3.42 (m, 6H), 3.48 (d, $J = 2.0$ Hz, 6H), 3.02 (tdd, $J = 26.4, 5.4, 2.0$ Hz, 3H), 2.75 (tdd, $J = 26.4, 5.4, 2.0$ Hz, 3H).

^{13}C NMR (CDCl_3 , 100 MHz) δ 146.2, 145.8, 143.1, 141.0, 139.4, 133.9, 133.5, 131.7, 131.3, 128.5, 128.1, 121.8, 121.7, 119.5, 119.0, 37.4, 30.8, 30.4. HRMS-APCI calcd for $\text{C}_{51}\text{H}_{36}$ ($M\text{-H}$) $^+$: 647.2739; found 647.2750.

3,6,9-Tri(pyren-2-yl)-4,7-dihydro-1H-cyclopenta[e]-as-indacene (152).

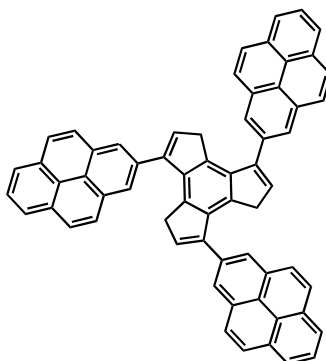

This compound was prepared in 81% yield according to the general procedure **B**, in 15 min., starting from tristriflate **129** and pyren-2-ylboronic acid. Yellow-green solid. m.p. > 250 °C (decomposition).

^1H NMR (CDCl_3 , 400 MHz) δ 8.28-8.08 (m, 27H), 8.07-7.97 (m, 3H), 6.29 (t, J = 1.6 Hz, 1H), 2.95-2.66 (m, 2H).

^{13}C NMR (CDCl_3 , 100 MHz) δ 143.97, 143.91, 143.8, 141.5, 134.2, 134.1, 133.8, 131.7, 131.3, 131.1, 130.0, 127.7, 127.6, 126.2, 126.0, 125.33, 125.27, 125.1, 124.8, 124.7, 37.5. HRMS-APCI calcd for $\text{C}_{63}\text{H}_{36}$ ($M\text{-H}$) $^+$: 791.2739; found 791.2708.

1H-Inden-2-ylboronic acid (153).³

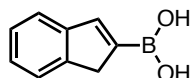

Gram scale synthesis. In a 3 necks dry round bottom flask adapted with reflux condenser, were placed magnesium turnings (972.0 mg, 40.00 mmol), and covered with 15 mL of dry THF. Two drops of 1,2-dibromoethane were added

and stirred by 3 min. followed by 2-bromoindene (3.21 g, 20.00 mmol) dissolved in 12 mL of dry THF. The reaction is refluxed and within few minutes takes a purple color. After stirred to reflux for 3 h, this formed grignard was transferred via canula, to another flask cooled to -78 °C containing trimethoxyborate (4.16 g, 40.00 mmol) in 25 mL of dry THF. Once transferred all the grignard, the flask is allowed to take room temperature and is stirred overnight. The reaction is quenched by adding 40 mL of water, 50 mL of HCl 10 % and stirred for 3 h. To the reaction mixture were added 80 mL of ether. The organic phase is separated and the aqueous phase extracted with ether (3x25 mL). The organic phases are collected, dried over magnesium sulfate and concentrated to dryness to yield a yellow solid (163.2 mg, 51%) corresponding to desired boronic acid. m.p. 146–147 °C.

^1H NMR (CDCl_3 , 400 MHz) δ 7.99 (bs, 1H), 7.60 (t, $J = 6.0$ Hz, 2H), 7.34 (quint, $J = 10.4$ Hz, 2H), 3.74 (bs, 2H).¹

^{13}C NMR (CDCl_3 , 100 MHz) δ 148.7, 147.9, 145.1, 126.7, 126.6, 124.3, 122.7, 41.2.

Potassium trifluoro(1*H*-inden-2-yl)borate (154).

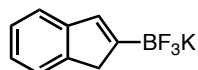

Gram scale synthesis. In a dry round bottom flask was dissolved 2-indenylboronic acid **153** (1.60 g, 10.00 mmol) in 25 mL of a methanol. Then aqueous KHF_2 4.5 M (11 mL, 60.00 mmol) was added in one portion. The reaction mixture is stirred for 40 min and the solvent is removed to complete dryness to get the crude of reaction. Boiling acetone (3x20 mL) is added directly to the crude and filtered from remaining inorganic salts. The acetone is evaporated to yield white flakes (1.69, 76%) corresponding to desired compound. m.p. >350 °C

^1H NMR (Acetone- d_6 , 400 MHz) δ 7.33 (d, $J = 7.3$ Hz, 1H), 7.20 (d, $J = 7.4$ Hz, 1H), 7.10 (t, $J = 7.3$ Hz, 1H), 6.97 (dd, $J = 9.3, 5.3$ Hz, 1H), 6.70 (s, 1H), 3.29 (s, 2H).

^{13}C NMR (Acetone- d_6 , 100 MHz) δ 148.7, 147.1, 131.3, 126.1, 123.8, 123.0, 119.9, 42.5.

^{11}B NMR (Acetone- d_6 , 400 MHz) δ 3.17. ^{19}F NMR (Acetone- d_6 , 400 MHz) δ -140.7. HRMS-ESI calcd for $\text{C}_9\text{H}_7\text{BF}_3\text{K}$ ($M\text{-K}$) $^+$: 183.0589; found 183.0587.

2-(1*H*-Inden-2-yl)benzo[*d*][1,3,2]dioxaborole (**155**).

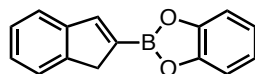

Gram scale synthesis. In a one neck round bottom flask, adapted with a dean stark trap, were placed 2-indenylboronic **153** (1.60 g, 10.0 mmol), catechol (1.1 g, 10.0 mmol), toluene (166.7 mL, 0.06 M) and ethanol (16.7 mL, 0.6 M). The mixture is refluxed for 4 h, and evaporated to dryness to yield a brown solid (2.30 g, 98 %) corresponding to desired product. m.p. 124.5–126 °C.

^1H NMR (CDCl_3 , 400 MHz) δ 7.94 (t, $J = 4.0$ Hz, 1H), 7.59 (t, $J = 8.0$ Hz, 2H), 7.36 – 7.33 (m, 2H), 7.31 (d, $J = 3.6$ Hz, 1H), 7.29 (d, $J = 3.6$ Hz, 1H), 7.13 (d, $J = 3.6$ Hz, 1H), 7.12 (d, $J = 3.6$ Hz, 1H), 3.79 (d, $J = 4.0$ Hz, 2H).

^{13}C NMR (CDCl_3 , 100 MHz) δ 148.7, 147.9, 145.1, 126.7, 126.6, 124.3, 122.7, 41.2. HRMS-APCI calcd for $\text{C}_{15}\text{H}_{11}\text{BO}_2$ ($M\text{-H}$) $^+$: 233.0848; found 233.0841.

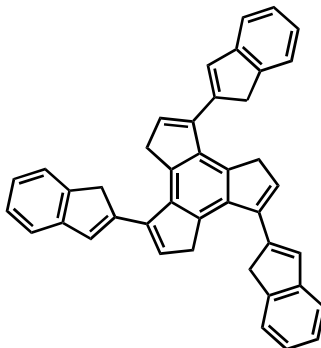
3,6,9-Tri(1*H*-inden-2-yl)-4,7-dihydro-1*H*-cyclopenta[*e*]-as-indacene (156).

Gram scale synthesis. In a 100 mL dry shlenck flask, were placed tristriflate (1.45 g, 2.28 mmol), 2-(1*H*-inden-2-yl)benzo[*d*][1,3,2]dioxaborole **155** (2.13 g, 9.12 mmol) or trifluoroborate salt **154** (2.53 g, 11.4 mmol), Pd(PPh₃)₄ (0.39 g, 0.342 mmol, 15 mol%), K₃PO₄ (2.42 g, 11.4 mmol) and 76 mL of dry and deoxygenated dioxane. The mixture is stirred 72 h at room temperature under argon atmosphere. The reaction is transferred to 500 mL flask and diluted with ethyl acetate (100 mL) and water (100 mL). The mixture is washed several times with water. The organic phase is dried over magnesium sulfate, and evaporated to dryness to get a black solid. The solid thus gotten is dissolved in chloroform and filtered trough a small silica gel bed that has been previously neutralized with a solution of 30% (Et₃N/Hex). The filtrate is evaporate to dryness and precipitated from acetone, to get a brown-dark solid (1.22 g, 68 %, from dioxaborole) or (1.07 g, 60 %, from trifluoroborate salt) of the desired compound. m.p. > 350 °C.

¹H NMR (CDCl₃, 400 MHz) δ 7.52 (d, *J* = 7.2 Hz, 1H), 7.47 (d, *J* = 7.2 Hz, 1H), 7.34 (t, *J* = 7.6 Hz, 1H), 7.24 (t, *J* = 7.6 Hz, 1H), 7.01 (t, *J* = 1.8 Hz, 1H), 6.49 (t, *J* = 1.6 Hz, 1H), 3.79 (d, *J* = 1.8 Hz, 1H), 3.61 (d, *J* = 1.8 Hz, 1H).

¹³C NMR (CDCl₃, 100 MHz) δ 145.5, 143.5, 143.2, 141.7, 139.8, 134.3, 133.0, 129.9, 126.8, 124.8, 123.8, 121.1, 43.4, 38.9. MALDI calcd for C₄₂H₃₀ (*M*+H)⁺: 535.2536; found 535.2530.

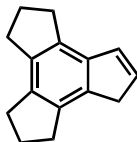
2,3,4,5,6,7-Hexahydro-1*H*-cyclopenta[*e*]-as-indacene (158).

2-Bromotrinden **163** (275.8 mg, 1.00 mmol) were placed in a two necks round bottom flask containing activated magnesium turnings (48.6 mg, 2.00 mmol) in 3 mL of dry THF. The mixture is heated to 60 °C for 4 h, after which the TLC show the complete consumption of starting material. The reaction is diluted with 10 mL of AcOEt and quenched by adding aqueous NH₄Cl. The organic phase is separated, dried over magnesium sulfate and purified by flash chromatography, to yield a white solid (111.8 mg, 57%) corresponding to the desired product. m.p. 66 – 67 °C.

¹H NMR (400 MHz, CDCl₃) δ 6.91 (tt, *J* = 5.6, 2Hz, 1H), 6.52 (tt, *J* = 5.6, 2Hz, 1H), 3.30 (s, 2H), 3.02 (t, *J* = 7.4 Hz, 2H), 2.90 (dt, *J* = 11.7, 7.3 Hz, 6H), 2.17 (dd, *J* = 14.7, 7.3 Hz, 4H).

¹³C NMR (CDCl₃, 100 MHz) δ 139.0, 138.4, 137.3, 137.2, 136.9, 134.8, 133.1, 130.8, 37.9, 31.5, 31.4, 31.2, 31.1, 25.9, 25.7. HRMS-APCI calcd for C₁₅H₁₆ (*M*-H)⁺: 195.1078; found 195.1072.

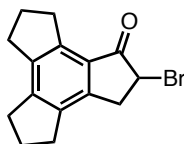
2-Bromo-2,3,4,5,6,7,8,9-octahydro-1*H*-cyclopenta[*e*]-as-indacen-1-one (160).

Gram scale synthesis. Trindanone **133** (5.00 g, 23.55 mmol) was dissolved in chloroform (500 mL, 0.05 M). Bromine (1.45 g, 47.10 mmol) dissolved in 50 mL of chloroform was added dropwise. The reaction is followed by TLC until consumption of starting material. The reaction is quenched by adding 500 ml of aqueous NaHCO₃. The organic phase is separated, dried and concentrate to dryness. Purification by flash chromatography yield (3.90 g, 78 %) of a brown oil corresponding to the desired compound. Brown oil.

^1H NMR (CDCl_3 , 400 MHz) δ 4.64 (dd, $J = 7.5, 3.1$, 1H), 3.69 (dd, $J = 18.0, 7.5$ Hz, 1H), 3.23 (t, $J = 7.7$, 3H), 2.94 – 2.78 (m, 6H), 2.19 (dt, $J = 10.5, 7.5$, 4H). ^{13}C NMR (CDCl_3 , 100 MHz) δ 200.0, 149.1, 145.3, 143.1, 141.3, 139.2, 128.0, 45.6, 37.1, 32.3, 31.3, 30.7, 30.12, 25.6, 25.3. HRMS-ESI calcd for $\text{C}_{15}\text{H}_{15}\text{BrO}$ ($M+\text{Na}$) $^+$: 313.0228; found 313.0217.

8-Bromo-2,3,4,5,6,7-hexahydro-1*H*-cyclopenta[*e*]-as-indacene (**162**).

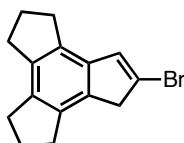

Gram scale synthesis. Bromoketone **160** (3.50 g, 11.99 mmol) was dissolved in 20 mL of a 1:1 MeOH / THF solution and cooled to 0 °C. NaBH_4 (500.0 mg, 13.19 mmol) is added in portions and the reaction is stirred for 30 min. After this time the reaction is neutralized with aqueous NH_4Cl . The organic phase is separated, dried and concentrated, to get a white solid corresponding to the halohydrine **161** (HRMS-ESI calcd for $\text{C}_{15}\text{H}_{17}\text{BrO}$ ($M+\text{Na}$) $^+$: 315.0360; found 315.0367). This solid and *p*-TSA (228.0 mg, 1.19 mmol) were suspended in toluene in a one neck round bottom flask adapted with a dean stark trap. The mixture is refluxed with the continuous remotion of water. The reaction is followed by TLC until complete consumption of starting material. Work up consists in the distillation of the solvent to dryness. The crude of the reaction is purified by flash chromatography to yield white needles (2.71 g, 82%) corresponding to the desired compound. m.p. 139-140 °C.

^1H NMR (400 MHz, CDCl_3) δ 6.94 (t, $J = 1.6$ Hz, 1H), 3.49 (bs, 2H), 2.94 (t, $J = 7.4$ Hz, 2H), 2.89 – 2.80 (m, 6H), 2.19 – 2.09 (m, 4H).

^{13}C NMR (CDCl_3 , 100 MHz) δ 138.8, 138.1, 137.2, 136.7, 136.1, 134.0, 131.9, 131.6, 123.4, 44.5, 31.5, 31.4, 31.0, 30.9, 25.8, 25.6. HRMS-ESI calcd for $\text{C}_{15}\text{H}_{15}\text{BrO}$ ($M+\text{Na}$) $^+$: 297.0354; found 297.0349.

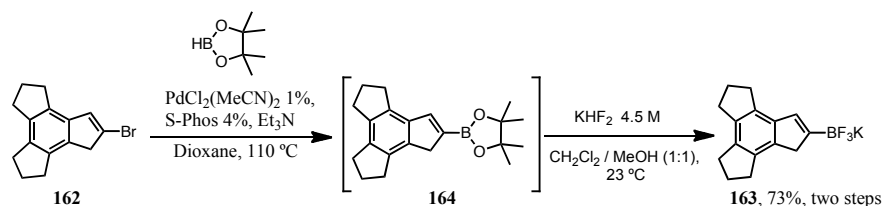

Gram scale synthesis. **Potassium trifluoro(4,5,6,7,8,9-hexahydro-1H-cyclopenta[e]-as-indacen-2-yl)borate (163).** In a dry round bottom flask was dissolved crude compound **164** (3.22 g, 10.00 mmol) in 50 mL of a 1:1 $\text{CH}_2\text{Cl}_2/\text{THF}$ mixture. Then aqueous KHF_2 4.5 M (11 mL, 60.00 mmol) was added in one portion. The reaction mixture is stirred for 40 min and the solvent is removed to complete dryness to get the crude of reaction. Boiling acetone (3x20 mL) is added directly to the crude and filtered from remaining inorganic salts. The acetone is evaporated to yield a beige needles (2.21 g, 73% two steps) corresponding to desired compound. m.p. 270-272 °C

^1H NMR (Acetone- d_6 , 400 MHz) δ 6.69 (d, J = 1.0 Hz, 1H), 3.15 (s, 2H), 2.91 (d, J = 7.4 Hz, 2H), 2.79 (ddd, J = 11.6, 9.4, 4.4 Hz, 4H), 2.06 (m, 6H).

^{13}C NMR (Acetone- d_6 , 100 MHz) δ 142.3, 140.1, 137.2, 136.7, 134.5, 133.1, 130.1, 40.7, 31.5, 31.4, 31.2, 31.1, 26.1, 25.9.

^{11}B NMR (Acetone- d_6 , 400 MHz) δ 2.96. ^{19}F NMR (Acetone- d_6 , 400 MHz) δ -140.5. HRMS-ESI calcd for $\text{C}_9\text{H}_7\text{BF}_3\text{K}$ ($M\text{-K}$) $^+$: 263.1315; found 263.1310.

Gram scale synthesis. 2-(4,5,6,7,8,9-hexahydro-1H-cyclopenta[e]-as-indacen-2-yl)-4,4,5,5-tetramethyl-1,3,2-dioxaborolane⁴ (**164**). This compound was synthesized using the described procedure. An oven-dried resealable Schlenk tube possessing a Teflon screw valve was charged with 2-bromotrindene (2.74 g, 10.00 mmol), $\text{PdCl}_2(\text{CH}_3\text{CN})_2$ (25.7 mg, 1 mol%) and S-Phos (164 mg, 4 mol%). The Schlenk tube was capped with a rubber septum and then evacuated and backfilled with argon two times. 1,4-Dioxane (10 mL) was added via syringe, through the septum, NEt_3 (4.2 mL, 3.54 g, 30.0 mmol) and pinacol borane 1 M (15 mL, 15 mmol) in a like manner. The septum was then replaced with a Teflon screw valve and the Schlenk tube was sealed. The reaction mixture was heated to 110 °C for 2 h and then allowed to cool to room temperature. The

reaction solution was filtered through a thin pad of alumine and the eluent was concentrated under reduced pressure. The crude material so obtained as a yellow-green oil (3.11 g, 96%) was pure enough and was used immediately in the next step without any purification.

^1H NMR (CDCl_3 , 400 MHz) δ 7.46 (t, $J = 2.0$ Hz, 1H), 3.46 (d, $J = 2.0$ Hz, 2H), 3.04 (t, $J = 7.4$ Hz, 2H), 2.90 (dt, $J = 22.7, 7.6$ Hz, 6H), 2.26-2.08 (m, 4H), 1.36 (s, 12H).

^{13}C NMR (CDCl_3 , 100 MHz) δ 144.8, 140.7, 139.3, 138.5, 138.5, 137.4, 135.9, 83.6, 40.2, 31.6, 31.5, 31.1, 31.1, 25.8, 25.6, 25.1, 24.8. HRMS-ESI calcd for $\text{C}_9\text{H}_7\text{BF}_3\text{K}$ ($M\text{-H}$) $^+$: 321.2026; found 321.2040.

7'-(4,5,6,7,8,9-hexahydro-1H-cyclopenta[*e*]-as-indacen-2-yl)-4,4'',5,5'',6,6',6',6'',7,7'',8,8'',9,9',9''-tetradecahydro-1H,1''H,3'H-2,1':4',2''-tercyclopenta[*e*]-as-indacene (166). The open shell C60

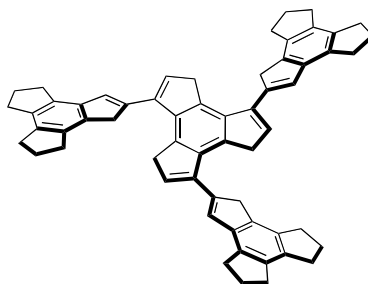

A screw-cap test-tube, equipped with a magnetic stir bar, was charged with triflitate **129** (150.0 mg, 0.19 mmol), potassium trifluoroborate salt **166** (258.3 mg, 0.86 mmol, 4.5 equiv), K_3PO_4 (181.1 mg, 0.86 mmol, 4.5 equiv) and $\text{Pd}(\text{PPh}_3)_4$ (32.9 mg, 0.75 mmol, 15 mol%). The vial was sealed with a teflon screw-cap, then evacuated and backfilled with argon. Deoxygenated dioxane (6.3 mL, 0.03 M) was added and stirred at 70 °C in a preheated oil bath for 3 h. The reaction is diluted with 10 mL of EtOAc. The organic phase was extracted and washed with water (5 x 20 mL), dried over magnesium sulfate and concentrated to dryness *without heating*. The crude product such gotten was purified by

preparative TLC (CH₂Cl₂/Hexane 20%) to yield a white solid (45.3 mg, 25%) corresponding to the desired open C₆₀ (**166**) m.p. > 220 °C (change of color).

¹H NMR (500 MHz, CDCl₃) δ 7.04 (t, *J* = 2.0 Hz, 3H), 6.48 (t, *J* = 2.0 Hz, 3H), 3.71 (t, *J* = 2.0 Hz, 6H), 3.63 (d, *J* = 2.0 Hz, 6H), 3.10 (t, *J* = 7.3 Hz, 6H), 3.03-2.85 (m, 15H), 2.21 (dt, *J* = 12.4, 7.3 Hz, 15H).

¹³C NMR (CDCl₃, 126 MHz) δ 142.4, 142.2, 139.9, 139.5, 138.8, 137.3, 137.1, 136.6, 134.8, 134.3, 132.5, 128.6, 42.0, 38.9, 31.6, 31.5, 31.2, 31.2, 25.9, 25.8. MALDI calcd for C₆₀H₅₄ (*M*+H)⁺: 775.4218; found 775.4222.

Diles-Alder tris-adduct (**168**).

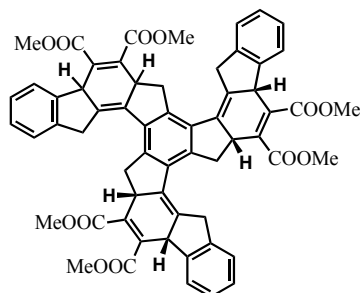

In a 5 mL dry round bottom flask, were mixed (106.8 mg, 0.2 mmol) of tris-diene **156**, dimethyl acetylenedicarboxylate (170.4 mg, 1.2 mmol) and 3 mL of toluene. The mixture was placed in a preheated bath at 120 °C and stirred by two hours. After this time, the flask was removed from the bath, the dissolvent was evaporated and the crude such gotten was purified by flash chromatography column to yield tris-adduct **167** (90 mg, 47%) as a dark orange solid. m.p. > 350 °C.

¹H NMR (500 MHz, CDCl₃) δ 2.3-5.5 (several multiplets), 7.1-8.0 (broad signals).

¹³C NMR (CDCl₃, 126 MHz) δ 35.0-54.0 (several signals), 123.0-145.0 (several signals), 175.0-183.0 (several signals).

HRMS-ESI calcd for C₆₀H₅₄ (*M*+H)⁺: 961.3219; found 961.3235.

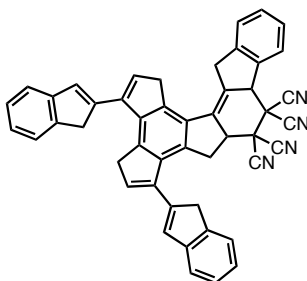
3,14-di(1*H*-inden-2-yl)-4,4a-dihydrodicyclopenta[*a,c*]indeno[2,1-*g*]fluorene-5,5,6,6(1*H*,6*aH*,11*H*,12*H*)-tetracarbonitrile (169).

In a 5 mL dry round bottom flask, were mixed (53.4 mg, 0.1 mmol) of tris-diene **156**, tetracyanoethylene (57.6 mg, 4.5 mmol) and 3 mL of dry toluene. The mixture was stirred by 16 hours. After this time, the dissolvent was evaporated and the crude such gotten was purified by flash chromatography column to yield mono-adduct **168** (90 mg, 77%) as a withe solid. m.p. > 300 °C.

^1H NMR (500 MHz, CDCl_3) δ 7.94 (s, 3H), 7.87 (s, 3H), 7.78 (s, 1H), 7.60 (d, $J = 2.8$ Hz, 3H), 7.55 (d, $J = 3.3$ Hz, 2H), 6.49 (s, 2H), 6.42 (s, 2H), 4.20 (d, $J = 6.5$ Hz, 2H), 4.06 (d, $J = 2.0$ Hz, 1H), 4.01 (d, $J = 1.9$ Hz, 1H), 3.40 (d, $J = 6.7$ Hz, 1H), 3.37 (d, $J = 6.7$ Hz, 1H), 3.33 – 3.25 (m, 5H), 3.21 (d, $J = 1.8$ Hz, 1H), 3.10 (d, $J = 1.7$ Hz, 1H), 3.05 (d, $J = 1.8$ Hz, 1H).

^{13}C NMR (126 MHz, CDCl_3) δ 145.4, 145.1, 143.1, 142.0, 140.9, 139.3, 134.9, 134.6, 134.2, 134.1, 133.7, 133.5, 133.4, 133.3, 133.0, 132.6, 130.2, 129.4, 128.3, 128.2, 128.17, 128.0, 127.8, 127.8, 127.7, 127.6, 127.4, 127.3, 126.9, 126.6, 126.58, 126.4, 125.0, 122.8, 116.7, 110.9, 110.5, 110.46, 109.2, 66.4, 53.9, 45.4, 38.6, 38.6, 37.9, 35.9, 29.9, 29.5, 14.3.

MALDI calcd for $\text{C}_{48}\text{H}_{30}\text{N}_4$ ($M+\text{Ag}$) $^+$: 805.1516; found 805.2071.

REFERENCES.

1. Ferrier, R. J.; Holden, S. G.; Gladkikh, O. *Perkin I* **2000**, *20*, 3505-3512.
2. Ranganathan, S.; Muraleedharan, K. M.; Rao, C.; Vairamani, M.; Karle, I. L. *Org. Lett.* **2001**, *3*, 2447-2449.
3. Ijpeij, E. G.; Beijer, F. H.; Arts, H. J.; Newton, C.; de Vries, J. G.; Gruter, M. *J. Org. Chem.* **2002**, *67*, 169-176.
4. Billingsley, K. L.; Buchwald, S. *J. Org. Chem.* **2008**, *73*, 5589-5591

UNIVERSITAT ROVIRA I VIRGILI
GOLD (I)-CATALYZED RETRO-CYCLOPROPANATION REACTION AND DEVELOPMENT OF TRINDANE-BASED
APPROACH TOWARD C60
Cesar Rogelio Solorio Alvarado
DL: T. 1714-2011

UNIVERSITAT ROVIRA I VIRGILI
GOLD (I)-CATALYZED RETRO-CYCLOPROPANATION REACTION AND DEVELOPMENT OF TRINDANE-BASED
APPROACH TOWARD C60
Cesar Rogelio Solorio Alvarado
DL: T. 1714-2011

GENERAL CONCLUSIONS

UNIVERSITAT ROVIRA I VIRGILI
GOLD (I)-CATALYZED RETRO-CYCLOPROPANATION REACTION AND DEVELOPMENT OF TRINDANE-BASED
APPROACH TOWARD C60
Cesar Rogelio Solorio Alvarado
DL: T. 1714-2011

GENERAL CONCLUSIONS OF THE TESIS

- We found the first example of a retro-cyclopropanation promoted by gold(I) which lead to the formation of free gold carbenes in solution. The generation of this species opens new possibilities to generate them in a safer manner and under mild conditions.

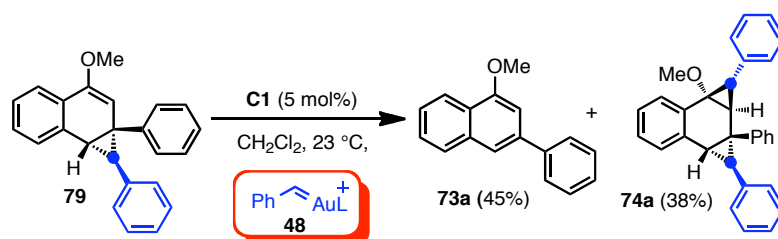

- I was developed a new annulation process which lead to the formation of monosubstituted naphthalenes and proceed by a cascade of reaction starting with cycloisomerization/1,5-OR shift/fragmentative retro-Diels-Alder. This annulation is very fast for free propargylic alcohols and in general proceed with excellent yields.

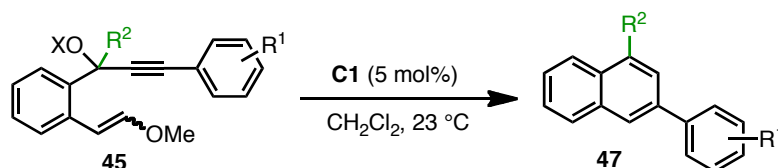

- Electrophilic Au(I) complexes promoted the retro-Buchner reaction of 7-aryl and vinyl 1,3,5-cycloheptatrienes to generate substituted gold(I) carbenes under catalytic conditions. This is the first report of the metal-promoted retro-Buchner reaction.

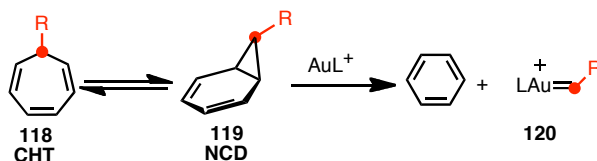

- These carbenes can be trapped by electron-rich as well as electron-poor alkenes in a new cyclopropanation reaction. This reaction is a safer alternative to the use of explosive diazo compounds as cyclopropanating reagents.

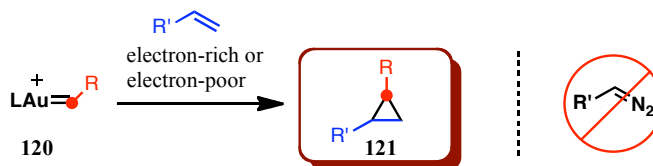

Palladium(II) chemistry:

- A convergent synthesis of an open shell C60 with all of the twelve pentagons present in C₆₀ was developed using trindane as the only building block.

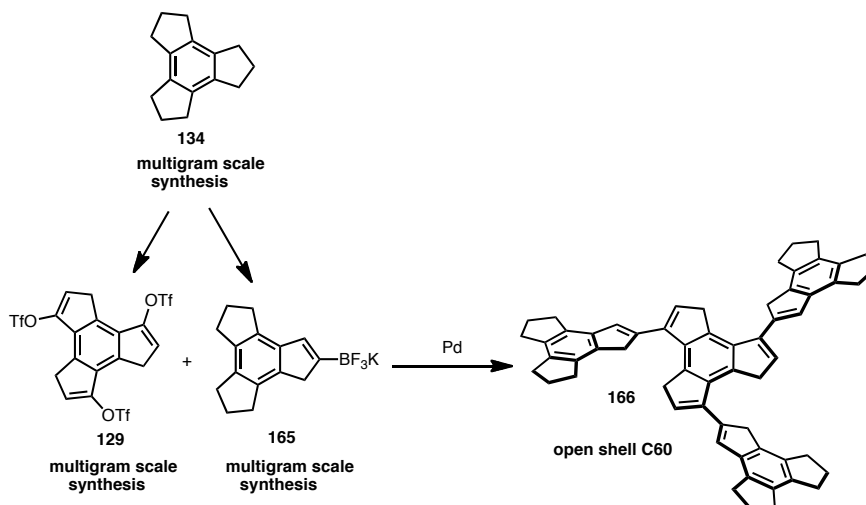

- We also developed a methodology for the synthesis of aryltrindenes by palladium catalyzed crosscoupling reactions.

