

[ED06] In-situ ultrasonic cleaning of crossflow sintered tube microfiltration: effect of sonication cycle time**Wan Rosmiza Zana Wan Dagang, Rosli Mohd Yunus, Adnan Ripin, Dayang Suhailawati bt Awang Sulong**

Faculty of Chemical and Natural Resources Engineering, Universiti Teknologi Malaysia, 81310 Skudai, Johor, Malaysia.

Introduction

Membrane separation in general and microfiltration in particular is frequently employed in the dairy, pharmaceutical, food, fermentation and biotechnology, and chemical industries.

During the microfiltration process, the membranes foul over time, as the retained particles accumulate on the membrane surface. Fouling results in a significant reduction in the separation efficiency by decreasing the permeate flux and increasing the pressure drop across the membrane. In normal membrane filtration, the operation is terminated when the flux reaches an uneconomical rate to continue. The membrane then goes through a cleaning or regeneration process before the filtration process can be resume.

There are a number of different chemical and physical cleaning methods currently used for membrane cleaning in industry. Chemical processes consume large volumes of expensive chemicals, while physical cleaning methods shows that the techniques will interrupt the continuous filtration process leading to a longer processing time.

The application of ultrasound wave fields in filtration operation, particularly membrane filtration, has been identified as a new and clean technology and as an alternative to the classical cleaning. Realizing the capability of ultrasound wave fields in cleaning processes, the technique was studied in this research to increase the rate of filtration of microfiltration membrane.

Materials and methods**Experimental set up**

The experiment set-up for this study is shown in Figure 1. A microfiltration stainless steel membrane with a pore size of 0.5 μm and length of 330.2 mm was used to study cross flow filtration of organic and inorganic sample. Transducers (40 kHz, 500 W) (Crest

Ultrasonic (M) Sdn. Bhd.) were attached on each side of the housing wall facing the membrane to transmit through intensity wave fields inside the membrane housing (M.H). In the membrane housing, a tubular stainless steel membrane was placed at the centre of the housing, where solids particles were retained on the membrane surface, while the permeate (P) flow passed through during the filtration process (figure 2). Referring to Figure 1, the filtration process started when the liquid suspension was delivered into the membrane housing by using a pump. The flowrate of the suspensions entering the filtration module was controlled by a pair of valves.

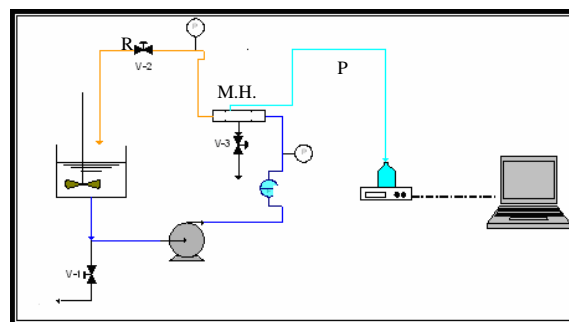

FIGURE 1 Experimental set-up for ultrasound-assisted cleaning of microfiltration membrane in a cross-flow unit.

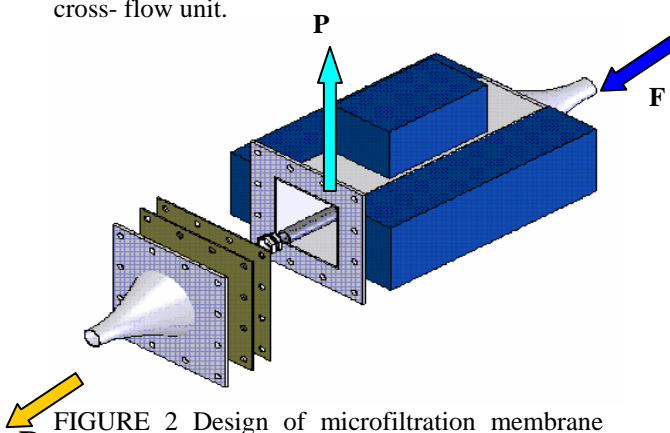

FIGURE 2 Design of microfiltration membrane housing with attachment of vibra- bar transducer (F: feed, P: permeate, R: retentate)

Design of Research Work

In this research, the experimental work was focused on the investigation of the ultrasonic effect on the filtration of organic (yis) and inorganic samples (titanium dioxide). In order to observe the ultrasonic effect, baseline or the reference conditions ought to be established. Thus, a series of non-sonicated filtration experiment was conducted to establish the general pattern of the filtration rate as a function of filtration time. Filtration experiment was then conducted with the presence of ultrasonic wave fields, with various settings of ultrasonic parameters.

Experimental procedure for baseline determination

In determining the effectiveness of ultrasound fields in enhancing the filtration rate, a baseline curve needs to be generated for each set of operating conditions. The baseline curve was generated by plotting the filtration rate versus the filtration time without presence of ultrasonic fields.

Throughout the whole experiment study, the filtration process was conducted in a close-loop manner, whereby the filtrate was recycled back into the feed tank.

After each run, the filtration system was cleaned thoroughly with a systematic method of cleaning, to achieve a consistent degree of cleanliness prior to the experiment.

Experimental method to determine the effectiveness of in-situ ultrasonic cleaning system

In order to carry out this stage of experiment, the ratio of sonicated and un-sonicated filtration time was varied. The degree of flux enhancement was determined by comparing the baseline curve with the curve generated from the ultrasound assisted filtration. The ultrasonic wave field was supplied intermittently for a specified interval after a specified un-sonicated filtration interval.

For organic sample with a fixed filtration time of 5 minutes, the sonication interval was varied from 5 to 15 minutes. Also, with a same fixed filtration time for inorganic sample, the interval time of sonication was varied from 3 to 10 minutes.

Results and Discussion

Experimental data for baseline determination

Figure 3 shows the typical curve of filtrate flux as a function of filtration time in the separation of organic sample and inorganic sample from the sample's solution. For duration of 90 minutes, in general, the curve shows a declining trend throughout the filtration process, indicating the continuous build-up of particulates onto the filtering medium. In the first 10 minutes of filtration shows the rapid decline of filtrate flux for both samples. This indicates the formation of the initial cake layer, completed within 10 minutes of filtration. After the rapid drop zone of filtration rate, both of the samples shows the slow decline of filtrate flux. As the filtration process exceeded the 40 minutes filtration time, the constant dropping rate of filtrate flux approached a near constant filtrate flux. This indicated that the rate of particle depositing on the membrane surface was balanced by the rate of particle removed from the surface via the crossflow action of the bulk fluid.

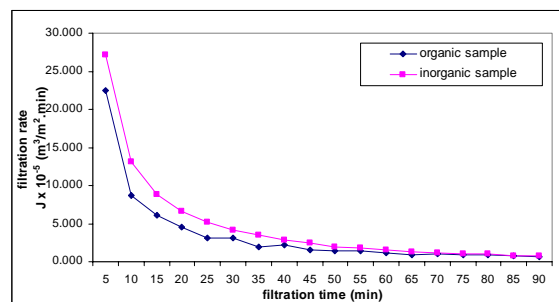

FIGURE 3 Typical curve of filtrate flux versus filtration time in the filtration of organic and inorganic samples

Effect of sonication cycle time

Figure 4 shows the effect of sonication on membrane permeate flux for a fixed filtration cycle time of 5 minutes on organic sample and figure 5 shows the effect of sonication for inorganic sample. As can be seen in the figures, the rate of filtration progressively dropped as the filtration commenced. This was due to the accumulation of particulates at the membrane surface as the suspension was forced through the filter media. The moment ultrasonic wave field was applied, the filtration rate showed an increasing trend.

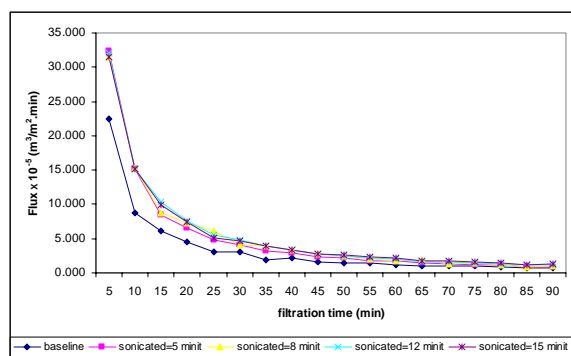

FIGURE 4 The effect of varying the sonication cycle time on the filtration of organic sample

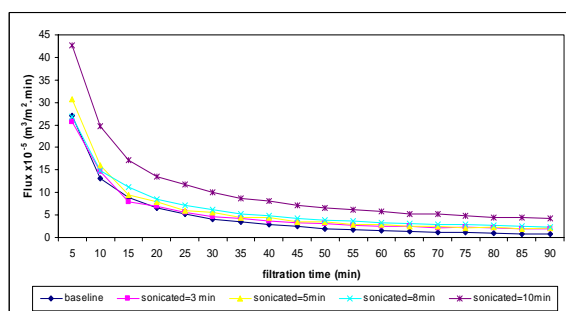

FIGURE 5 The effect of varying the sonication cycle time on the filtration of inorganic sample

As can be seen from the figure above, the plotted curves were smoother, but the overall trend of the curves remained unchanged. In comparison to the baseline curve, all the sonicated experiments showed higher rate of filtration. The general trend observed in the figure was the shortening of filtration time to reach plateau filtration rate as the ultrasonic cycle time was increased. This phenomenon indicated the influence of ultrasound filed in arranging the solids particulate during the formation of cake layer. A longer duration of sonicated cycle time produced more porous structure of cake layer. Upon switching off the ultrasonic field, further settling of particulates on the formed porous cake structure did not greatly alter the filtration rate, and hence enabling a higher equilibrium filtration rate. Table 1 shows a summary of the percent increment of filtration rate in comparison to the unsonicated filtration experiment. The flux increment varied from 46.63% to 58.13% as the sonication cycle time was varied from 5 to 15 minutes for organic sample, while for inorganic sample, the flux increment showed higher than organic sample which are from 14.65% up to 123.51%. The higher flux

increment observed, was consistent with the experimental expectation, since the increased sonication cycle time would result in longer period of particulate dispersion and greater cake thinning.

TABLE 1 Percentage of flux increment as a function of sonication cycle time at 5 minutes filtration cycle time

Sonication time (min)	Percent increment
Organic Sample	
5	46.63
8	53.62
12	59.53
15	58.13
Inorganic Sample	
3	14.65
5	29.74
8	35.70
10	123.51

Acknowledgements

The authors wished to thank the Ministry of Science, Technology and Innovation (MOSTI), Malaysia for the National Science Fellowship awarded to Wan Rosmiza Zana Wan Dagang. The authors were also grateful to Assoc.Prof. Dr. Rosli Mohd Yunus for his invaluable assistance and excellent supervision throughout this study.

References

- Coulson, J.M. and Richardson, J.F. (1991). Particle Technology and Separation Processes, Chemical Engineering. Vol.2. 4th ed. Pergamon Press.
- Rosli Mohd Yunus (1996). Ultrasound Fields In Crossflow Microfiltration. University of Wales Swansea: Ph.D. Thesis
- Porter, M.C. (1990). Handbook of Industrial Membrane Technology. New Jersey, USA: Noyes Publications.
- Shobha Muthukumar, Yang, K., Annette Seuren, Sandra Kentish, Muthupandian Ashokkumar, Stevens, G.W., Grieser, F. (2002). The Use of Ultrasonic Cleaning for Ultrafiltration Membranes in the Dairy Industry. *Journal of Membrane Science*. **384**. Australia: University Melbourne.