

**DESIGN AND IMPLEMENTATION OF MOTION SENSITIVE  
UHF RFID SYSTEM**

**by**

**SHABINAR BINTI ABDUL HAMID**

**Thesis submitted in fulfillment of the requirements for the degree of  
Master of Science**

**January 2011**

# **DESIGN AND IMPLEMENTATION OF MOTION SENSITIVE UHF RFID SYSTEM**

## **ABSTRACT**

Radio Frequency Identification (RFID) is a method of remotely storing and retrieving data using devices called RFID tags. RFID system components comprise of RFID tag and RFID reader. The RFID tag stores a unique identification of the object that is attached to it. However, it does not provide information about the conditions of the object that it detects. Sensor node in Wireless Sensor Network (WSN), on the other hand, provides information about the condition of the object and its environment. Therefore, with the integration of RFID and WSN technology, their disadvantages can be overcome and their advantages can be put into some important applications. The anti-theft system is one of such application that can benefit from the integration of technologies. The work presented in this thesis contributes to the research of the motion sensitive 433 MHz active RFID system in several ways such as (a) the development of novel interrupt-based motion sensitive RFID tag that send data in real-time; (b) the design and development of low power RFID tag; and c) the performance evaluation of RFID system in various aspects including maximum read range measurement in indoor and outdoor environments, motion detection accuracy, multi-tag communication efficiency and the estimation for power consumption of the tag. This project is divided into two parts. The first part is the hardware design and development of an active RFID system component; RFID reader and RFID tag. The processes involved in designing the hardware include selection of components, circuits design, PCBs layout, PCBs fabrication and components assembly. The RFID tag and RFID reader prototype are successfully fabricated with the size of 55 mm x

45 mm x 27 mm and 95 mm x 97 mm x 24 mm, respectively. The second part is the software design and development for RFID tag and RFID reader. The reader operation adopts Basic Framed Slotted Aloha algorithm for multi-tag identification. The RFID system employs multi-protocol such as Reader-Talks-First (RTF) and Tag-Talks-First (TTF) for effective communication. The proposed prototype of the active RFID system has gone through real-world environment testing. It is observed that the lifespan of tag battery is inversely proportional to the current and time consumption. Consequently, the low sleep-mode current prolong RFID tag battery lifetime. It is found that the prototype RFID system can detect motion in 100% accuracy rate, achieved maximum read range of 56 meters indoor and 94 meters outdoor, in typical application and 84.67% efficiency in multi-tag communications. As for future scope, few suggestion has been identified such as a) to expand the research on the metal effect on range of communication; b) to reduce the size of prototype devices by using microcontroller that has built-in real-time clock; c) to extend the flexibility of the RFID tag operation by implementing dual antenna to the RFID tag that can be operated at 433 MHz and 915 MHz band; and d) to improve the efficiency of RFID system by developing anti-collision algorithm for high capacity tags and multi-reader communication.

# **REKABENTUK DAN IMPLEMENTASI SISTEM PENGENALAN FREKUENSI RADIO UHF SENSITIF GERAKAN**

## **ABSTRAK**

Pengenalan menggunakan frekuensi radio (RFID) adalah kaedah menyimpan dan memperoleh semula maklumat secara jauh dengan menggunakan peranti yang dinamakan penanda RFID. Komponen-komponen sistem RFID terdiri daripada penanda RFID dan pembaca RFID. Penanda RFID menyimpan maklumat unik pengenalan objek yang terkepil pada penanda tersebut. Walaupun demikian, ia tidak membekalkan maklumat mengenai keadaan objek yang dikesannya. Nod sensor di dalam Rangkaian Sensor Tanpa Wayar (WSN), sebaliknya, membekalkan maklumat mengenai keadaan objek dan persekitarannya. Oleh itu, dengan gabungan teknologi RFID dan WSN, kelemahan kedua-duanya boleh diatasi dan kelebihan kedua-duanya boleh digunakan untuk aplikasi yang penting. Sistem anti-pencuri adalah salah satu aplikasi yang dapat memperoleh faedah dari gabungan teknologi-teknologi ini. Kerja yang dibentangkan di dalam tesis ini menyumbang kepada sistem 433 MHz RFID aktif sensitif gerakan meliputi beberapa segi seperti a) prototaip sampukan berasaskan penanda RFID yang sensitif gerakan menghantar maklumat dalam masa nyata; (b) rekabentuk dan pembangunan penanda RFID yang berkuasa rendah; dan c) menilai perlaksanaan sistem RFID dalam pelbagai aspek termasuklah julat bacaan maksimum di dalam dan di luar persekitaran, kejituan pengesanan gerakan, kecekapan komunikasi berbilang-penanda, dan penganggaran kuasa yang digunakan oleh penanda RFID. Projek ini dibahagikan kepada dua bahagian. Bahagian pertama adalah rekabentuk dan pembangunan perkakasan komponen-komponen sistem aktif RFID; penanda RFID dan pembaca RFID. Proses yang terbabit dalam merekabentuk

perkakasan termasuklah pemilihan komponen-komponen, merekabentuk litar-litar, pembentangan papan litar tercetak (PCB), pembikinan PCB dan pemasangan komponen-komponen. Prototaip penanda dan pembaca RFID berjaya dibina dengan masing-masing bersaiz 55mm x 45mm x 27mm dan 95mm x 97mm x 24mm. Bahagian kedua adalah rekabentuk dan pembangunan aturcara komputer untuk penanda dan pembaca RFID. Pembaca RFID mengadaptasi algoritma Asas Kerangka Slot Aloha (BSFA) untuk pengesanan berbilang-penanda. Sistem RFID menggunakan berbilang-protokol seperti Pembaca-Berbicara-Pertama (RTF) dan Penanda-Berbicara-Pertama (TTF) bagi berkomunikasi dengan cekap. Prototaip sistem RFID aktif telah melalui ujian dunia persekitaran nyata. Adalah diperhatikan tempoh hayat bateri penanda RFID adalah berkadaran songsang dengan tempoh dan arus aliran elektrik yang digunakan. Didapati bahawa arus aliran elektrik yang rendah ketika mod tidur memanjangkan tempoh hayat bateri penanda RFID. Prototaip system RFID didapati boleh mengesan gerakan pada kadar ketepatan 100%, mencapai jarak maksimum bacaan sebanyak 56 meter dalam dan 94 meter luar, dalam penggunaan biasa dan 84.67% keberkesanan dalam komunikasi berbilang-penanda. Sebagai skop masa hadapan, beberapa saranan telah dikenalpasti seperti a) meluaskan kajian ke atas kesan logam kepada jarak komunikasi; b) mengurangkan saiz prototaip peranti-peranti dengan menggunakan mikrokontroler yang mempunyai jam masa nyata; c) melaksanakan dwi antena kepada penanda RFID yang beroperasi dalam jalur frekuensi 433 MHz dan 915 MHz; dan d) memperbaiki kecekapan sistem RFID dengan membangunkan anti-pertembungan algoritma bagi penanda-penanda berkapasiti tinggi dan berbilang-pembaca berkomunikasi.

## ACKNOWLEDGMENTS

My humble gratitude towards almighty Allah S.W.T for blessing me with opportunities and gratitude. I am deeply indebted to my supervisor, Dr. Widad Ismail whose help, stimulating suggestions and encouragement helped me in all my time of research for and writing this thesis. I am also deeply grateful to my co-supervisor, Dr. Zaini Halim for her valuable support. It was indeed an honor to work under them. I would also like to thank my sponsor, UiTM for giving me a chance to pursue my studies in this area.

I would like to thank the entire Electrical Engineering Department for making such an enjoyable place to work. The support of administrative and technical staff especially Encik Latip, Encik Elias and Encik Azam helped in easy access of resources as and when needed.

Next I would like to thank my friends for all their support, interest and valuable hint. Especially I am obliged to Umi Rushaidah, Nuriazen, Shahlinaz, Najwan, Hafsha and Amin.

Lastly, I would like to thank my parents, Aminah and Abdul Hamid, and siblings for their prayers and full support throughout the years. Especially, I would like to give my special thanks to my loving husband, Shaharani and dearest son, Muhammad Afiq, whose love, patience, and support enabled me to complete this work. Their constant affection and encouragement have helped me achieve my goals.

Shabinar Binti Abdul Hamid

January 2011

## TABLE OF CONTENTS

ABSTRACT	ii
ABSTRAK	iv
ACKNOWLEDGEMENTS	vi
TABLE OF CONTENTS	vii
LIST OF TABLES	xii
LIST OF FIGURES	xiv
LIST OF ABBREVIATIONS	xix
CHAPTER 1 INTRODUCTION	1
1.1 Overview of Radio Frequency Identification and Wireless Sensor Network	1
1.2 Research Motivation	3
1.3 Thesis Objectives	3
1.4 Requirements	4
1.5 Research Methodology	4
1.6 Thesis Outline	6
CHAPTER 2 LITERATURE REVIEW	7
2.1 Introduction	7
2.2 Components of RFID System	8
2.2.1 RFID Tag	8
2.2.2 RFID Reader	13
2.3 Review of Motion Sensor Technologies for RFID Tag	15
2.3.1 Passive Infra Red Sensor	15
2.3.2 Microwave Motion Sensor	15
2.3.3 Accelerometer	16
2.3.4 Vibration Sensor	17
2.4 RF Transceiver for the Proposed RFID System	19
2.5 Microcontroller for the Proposed RFID System	20
2.6 Radio Frequency Communications Protocol	24
2.6.1 Reader-Talks-First Protocol	24
2.6.2 Tag-Talks-First Protocol	24
2.7 Anti-Collision Algorithms	25

2.7.1	Pure Aloha Algorithm	26
2.7.2	Slotted Aloha Algorithm	27
2.7.3	Framed Slotted Aloha Algorithm	27
2.7.3(a)	Basic Framed Slotted Aloha Algorithm	28
2.7.3(b)	Dynamic Framed Slotted Aloha Algorithm	29
2.8	433 MHz Frequency Attributes and Air Interface Standard	30
2.9	Summary	32
<b>CHAPTER 3 DESIGN METHODOLOGY OF THE PROPOSED RFID SYSTEM</b>		<b>34</b>
3.1	Introduction	34
3.2	PIC18LF252 Microcontroller	35
3.2.1	Input/Output (I/O) Ports	36
3.2.2	Serial Peripheral Interface (SPI)	37
3.3	CC1100 RF Transceiver	38
3.3.1	Interface Configuration	42
3.3.2	Software Configuration	42
3.3.3	Operational States (Modes)	43
3.3.4	General Control Pins	45
3.3.5	Automated Packet Handling	46
3.3.6	Data Whitening	47
3.3.7	Packet Format	47
3.3.8	Packet Filtering in Receive Mode	50
3.3.9	Received Signal Strength Indicator (RSSI)	51
3.3.10	Manchester Encoding	52
3.4	Vibration Sensor	53
3.5	DS1306 Real-time Clock	55
3.6	MAX3222 Serial Converter	59
3.7	Design Specification of the Proposed RFID System	60
<b>CHAPTER 4 HARDWARE DEVELOPMENT AND IMPLEMENTATION</b>		<b>61</b>
4.1	Overview	61
4.2	Prototype Fabrication	63
4.3	433 MHz an Active RFID Tag Design with Motion Sensor Integration	64



4.3.1	RFID Tag Architecture Design	64
4.3.2	Microcontroller Interface to the Vibration Sensor	65
4.3.3	Schematic of an Active RFID Tag	67
4.3.4	PCB Layout of an Active RFID Tag	69
4.3.5	Component Layout of an Active RFID Tag	70
4.3.6	Raw PCB of an Active RFID Tag	71
4.3.7	An Active RFID Tag Antenna	72
4.3.8	Active RFID Tag Prototype	74
4.4	433 MHz Active RFID Reader Design with Motion Sensor Application	77
4.4.1	RFID Reader Architecture Design	77
4.4.2	Schematic of RFID Reader	78
4.4.3	PCB Layout of RFID Reader	80
4.4.4	Components Layout of RFID Reader	81
4.4.5	Raw PCB of RFID Reader	82
4.4.6	RFID Reader Prototype	83
4.5	Summary	85
CHAPTER 5 SOFTWARE DEVELOPMENT AND IMPLEMENTATION		87
5.1	Introduction	87
5.2	Software Development Tools	89
5.2.1	MPLAB Integrated Development Environment	89
5.2.2	Melabs Programmer	89
5.3	Application Overview and Communication Protocols	91
5.4	Software Algorithm	93
5.4.1	Initialization Setup	93
5.4.1(a)	SPI Mode Configuration	93
5.4.1(b)	Real-time Clock Initialization	95
5.4.1(c)	CC1100 Register Settings	96
5.4.1(d)	Frequency Synthesizer Calibration	98
5.4.1(e)	Power Table Setting	98
5.4.2	Packet Specification	99
5.4.3	Motion Detection Algorithm	100
5.4.3(a)	Procedure to Determine Sampling Period Parameters	101
5.4.3(b)	Software Algorithm to Determine Sampling Period	104

5.4.3(c)	Experiment to Determine Optimum Sampling Period for Anti-Theft System	107
5.4.3(d)	Result and Discussion of Sampling Period Experiment	109
5.4.4	Process of Transmitting a Packet	111
5.4.5	Process of Receiving a Packet	113
5.4.6	Anti-collision Algorithm	115
5.4.7	RFID Reader Algorithm	116
5.4.8	Frame Size Selection Method	119
5.4.9	RFID Tag Algorithm	120
5.4.10	Random Slot Number and Time Slot Allocation	123
5.5	Summary	126
CHAPTER 6 RESULTS AND DISCUSSION OF THE PROPOSED RFID SYSTEM		127
6.1	Overview	127
6.2	Application Interface Setup	127
6.3	Operating Frequency Verification	129
6.4	Periodic Transmission Accuracy Test	130
6.5	Anti-collision Algorithm Performance Analysis	132
6.5.1	Result and Analysis for Tag Collection Process without Anti-collision Protocol	135
6.5.2	Result and Analysis for Tag Collection Process with Anti-collision Protocol	137
6.5.3	Result and Analysis for Tag Collection Process with an Increased Read Range	138
6.6	Radiation Pattern Measurement	139
6.6.1	Vertical Polarization Measurement	140
6.6.2	Horizontal Polarization Measurement	145
6.7	RF Communication Performance in Multi-Floored Building	146
6.8	Maximum Read Range Measurement	149
6.9	Output Power versus Read Range Measurement	151
6.10	Attenuation Test	152
6.11	Tag Accuracy Evaluation in Detecting Motion of Tagged Object	153
6.12	Energy Analysis	155

6.12.1	Calculated Current Consumption	159
6.12.2	Measured Current Consumption	160
6.12.3	An Active RFID Tag Battery Life Estimation	162
6.13	Proposed 433 MHz Active RFID System Analysis	162
6.14	Summary	164
CHAPTER 7 CONCLUSIONS AND FUTURE SCOPE		167
7.1	Conclusions	167
7.2	Future Scope of the Project	168
PUBLICATION & PATENT		170
REFERENCES		171
Appendix A: Real-time Clock Registers and Address Map		179
Appendix B: Radiation Pattern of SMD Antenna		180
Appendix C: Source Code of RFID Reader		181
Appendix D: Source Code of RFID Tag		194

## LIST OF TABLES

Table 2.1: RFID tag attributes	10
Table 2.2: Summary of manufacturer's specifications of RF transceiver	20
Table 2.3: Comparison between AT89C51RC2 and PIC18LF252 specifications	23
Table 2.4: Characteristics of RFID operating frequencies	31
Table 3.1: Current consumption specification of PIC18LF252	36
Table 3.2: Current consumption specification of CC1100	39
Table 3.3: State transition timing	45
Table 3.4: Current consumption specification of DS1306	59
Table 3.5: RFID reader specifications	60
Table 3.6: RFID tag specifications	60
Table 4.1: List of RFID tag components	76
Table 4.2: List of RFID reader components	84
Table 4.3: Summary of an active RFID tag design	85
Table 4.4: Summary of an active RFID reader design	86
Table 5.1: Day setting reference	96
Table 5.2: Configuration register settings	97
Table 5.3: General packet format	100
Table 5.4: Tag payload format	100
Table 5.5: Reader payload format	100
Table 5.6: Sampling period test matrix	109
Table 5.7: Raw data of sampling period analysis	109
Table 5.8: Average detection data captured in x- and y- direction	110
Table 6.1: The test matrix for read range measurement	150
Table 6.2: Result of maximum read range measurement for indoor environment	150
Table 6.3: Result of maximum read range measurement for outdoor environment	150
Table 6.4: Result of attenuation measurement	153
Table 6.5: Measured data	158
Table 6.6: Current consumption per circuit	159
Table 6.7: Time usage percentage of each mode	160

Table 6.8: Calculated current consumption of the tag for a period of an hour	160
Table 6.9: Measured current consumption of the tag for a period of an hour	162
Table 6.10: RFID reader specifications	163
Table 6.11: RFID tag specifications	163
Table 6.12: Comparison of the proposed RFID system with other designs	164

## LIST OF FIGURES

Figure 1.1: Design methodology flow chart	5
Figure 2.1: Passive RFID system	9
Figure 2.2: Block diagram of an active RFID tag	9
Figure 2.3: Simple architecture of an active RFID reader	13
Figure 2.4: Improved architecture of the active RFID reader	14
Figure 2.5: Mercury based vibration sensor	17
Figure 2.6: Side view of non-mercury based vibration sensor	18
Figure 2.7: Interactions between a reader and tags	25
Figure 2.8: Principle of Pure Aloha	26
Figure 2.9: Principle of Slotted Aloha	27
Figure 2.10: Principle of Basic Framed Slotted Aloha	29
Figure 2.11: Principle of Dynamic Framed Slotted Aloha	30
Figure 3.1: Structure of an active RFID system	35
Figure 3.2: Hardware selection process flow chart	35
Figure 3.3: SPI connection between microcontroller, RF transceiver and real-time clock in the proposed RFID system	38
Figure 3.4: Connection between CC1100 and PIC18LF252 microcontroller in the proposed RFID system	40
Figure 3.5: (a) Top and (b) bottom view of CC1100EMK Evaluation Module	41
Figure 3.6: Application circuit for 433 MHz CC1100EMK Evaluation Module	41
Figure 3.7: Configuration interface of SmartRF® Studio	43
Figure 3.8: State diagram of CC1100	44
Figure 3.9: Packet format	49
Figure 3.10: Received packet format	51
Figure 3.11: Manchester encoding	52
Figure 3.12: Vibration sensor	53
Figure 3.13: Behavior of conductive balls inside vibration sensor when (a) at rest and (b) in motion	54
Figure 3.14: Typical operating circuit of vibration sensor	55
Figure 3.15: Connection between real-time clock and microcontroller in the proposed RFID tag design	56

Figure 3.16: 8-bit (a) write and (b) read sequence	57
Figure 3.17: Real-time clock settings interface	58
Figure 3.18: Connection between MAX3222 and microcontroller in the proposed RFID reader design	59
Figure 4.1: Methodology of hardware design and development	62
Figure 4.2: Hardware of RFID reader assembled on veroboard	63
Figure 4.3: Architecture of an active RFID tag	65
Figure 4.4: Connection between vibration sensor and microcontroller	66
Figure 4.5: Schematic of RFID tag	68
Figure 4.6: Top layer of the RFID tag PCB	69
Figure 4.7: Bottom layer of the RFID tag PCB	69
Figure 4.8: Top side component layout of the RFID tag	70
Figure 4.9: Bottom side component layout of the RFID tag	70
Figure 4.10: Top view of raw RFID tag PCB	71
Figure 4.11: Bottom view of raw RFID tag PCB	71
Figure 4.12: Surface mount antenna for RFID tag	73
Figure 4.13: Measured return loss, S <sub>11</sub> of 433 MHz SMD antenna	74
Figure 4.14: RFID tags prototype	75
Figure 4.15: Top view of assembled RFID tag PCB without CC1100 module	75
Figure 4.16: RFID tag attached to the asset (laptop)	76
Figure 4.17: Architecture of RFID reader	78
Figure 4.18: Schematic of RFID reader	79
Figure 4.19: Top layer of RFID reader PCB	80
Figure 4.20: Bottom layer of RFID reader PCB	80
Figure 4.21: Top side component layout of RFID reader	81
Figure 4.22: Top view of raw RFID reader PCB	82
Figure 4.23: Bottom view of raw RFID reader PCB	82
Figure 4.24: RFID reader prototype	83
Figure 4.25: The arrangement of RFID-based anti-theft system	84
Figure 5.1: Illustration of the proposed UHF RFID system	87
Figure 5.2: Methodology of software design and development	88
Figure 5.3: Sample content of hex file	90
Figure 5.4: Melabs U2 programmer board connection to RFID tag	91

Figure 5.5: Implementation scheme of RTF and TTF protocol	92
Figure 5.6: Configuration registers write and read operation	94
Figure 5.7: 8-bit read sequence	94
Figure 5.8: 8-bit write sequence	95
Figure 5.9: Real-time clock setting interface	96
Figure 5.10: Methodology of motion detection algorithm	101
Figure 5.11: Hardware setup for sampling period analysis	102
Figure 5.12: The waveform captured at the input pin of microcontroller	103
Figure 5.13: Minimum and maximum interval of switch closure	104
Figure 5.14: Algorithm to analyze optimum sampling period	106
Figure 5.15: Sampling period experimental setup	107
Figure 5.16: Orientation of vibration sensor on RFID tag PCB	108
Figure 5.17: Detection rate of sampling period	111
Figure 5.18: Flow chart of transmission algorithm	112
Figure 5.19: Flow chart of receiving algorithm	114
Figure 5.20: Flow chart of the proposed anti-collision algorithm	116
Figure 5.21: Flow chart of RFID reader operation	118
Figure 5.22: Print screen result of RFID system communication	120
Figure 5.23: Flow chart of RFID tag operation	122
Figure 5.24: Transmit timeout	125
Figure 5.25: Receive timeout	125
Figure 6.1: (a) Serial port configuration and (b) ASCII setup dialog box of Hyper Terminal program	128
Figure 6.2: The experimental hardware setup	129
Figure 6.3: Received signal viewed on spectrum analyzer	130
Figure 6.4: Pseudo code for RFID tag	130
Figure 6.5: Pseudo code for RFID reader	131
Figure 6.6: Periodic transmission timing result	132
Figure 6.7: Test arrangement for anti-collision evaluation	133
Figure 6.8: Flow chart of the algorithm of the RFID system without anti-collision protocol	134
Figure 6.9: Flow chart of the algorithm of the RFID system with anti-collision protocol	135



Figure 6.10: Tag collection result without anti-collision protocol	136
Figure 6.11: Tag collection result with anti-collision protocol	138
Figure 6.12: Tag collection result at 10 meters read range	139
Figure 6.13: (a) Whip and (b) Vivaldi antenna in vertical polarization	140
Figure 6.14: The experimental arrangement for vertical polarization measurement	141
Figure 6.15: RFID reader algorithm for radiation pattern measurement	142
Figure 6.16: RFID tag algorithm for radiation pattern measurement	143
Figure 6.17: Vertical polarization radiation pattern of Whip antenna measured at (a) 2 meters and (b) 10 meters read range	144
Figure 6.18: Vertical polarization radiation pattern of Vivaldi antenna measured at 2 meters and (b) 10 meters read range	144
Figure 6.19: The experimental arrangement for horizontal polarization measurement	145
Figure 6.20: Horizontal polarization radiation pattern of Whip antenna measured at (a) 2 meters and (b) 10 meters read range	145
Figure 6.21: Horizontal polarization radiation pattern of Vivaldi antenna measured at (a) 2 meters and (b) 10 meters read range	146
Figure 6.22: The experimental arrangement for multi-floored read range measurement	147
Figure 6.23: Measured radiation pattern of Whip antenna as a function of read range in multi-floored building	148
Figure 6.24: Measured radiation pattern of Vivaldi antenna as a function Of read range in multi-floored building	148
Figure 6.25: Measured read range as a function of output power using (a) a Whip and (b) a Vivaldi reader antenna	151
Figure 6.26: The experimental arrangement for tag accuracy test in detecting motion of tagged object	153
Figure 6.27: Data logging on Hyper Terminal used in the proposed anti-theft RFID-based system	155
Figure 6.28: Hardware arrangement for current measurement	156
Figure 6.29: Current consumption during receiving cycle	157
Figure 6.30: Current consumption during transmission cycle	158



## LIST OF ABBREVIATIONS

ACK:	Acknowledge
ADC:	Analog-Digital-Converter
AIE:	Alarm Interrupt Enable
ASK:	Amplitude-shift Keying
ATM:	Automated Teller Machine
BCD:	Binary-coded Decimal
BFSA:	Basic Framed Slotted Aloha
BFSK:	Binary Frequency-shift Keying
CKE:	Clock Edge
CKP:	Clock Polarity
CMOS:	Complementary Metal-Oxide Semiconductor
CPU:	Central Processing Unit
CRC:	Cyclic Redundancy Check
CS:	Chip Select
CST:	Computer Simulation Technology
DC:	Direct Current
DFSA:	Dynamic Framed Slotted Aloha
DIP:	Dual in-line Packaging
EEPROM:	Electrically Erasable Programmable Read-Only Memory
EIRP:	Effective Isotropic Radiated Power
EPC:	Electronic Product Code
FEC:	Forward Error Correction
FIFO:	First-In-First-Out
FSA:	Framed Slotted Aloha
FSK:	Frequency-Shift Keying
GFSK:	Gaussian Frequency-Shift Keying
GND:	Ground
GSM:	Global System for Mobile
HF:	High Frequency
IC:	Integrated circuit
ID:	Identification
I <sup>2</sup> C:	Inter IC

ICSP: In-circuit Serial Programming  
IDE: Integrated Development Environment  
IEC: International Electrotechnical Commission  
IFF: Identify Friend or Foe  
I/O: Input/Output  
ISFET: Ionic Sensitive Field Effect Transistor  
ISO: International Organization of Standardization  
ISM: Industrial, Scientific and Medical  
LCD: Liquid Crystal Display  
LED: Light-emitting Diode  
LF: Low Frequency  
LOS: Line-Of-Sight  
LQI: Link Quality Indicator  
MCU: Microcontroller Unit  
MSK: Minimum-shift Keying  
MSSP: Master Synchronous Serial Port  
NLOS: Non-Line-of-Sight  
OOK: On-off Keying  
OS: Operating System  
PA: Power Amplifier  
PC: Personal Computer  
PCB: Printed Circuit Board  
PIC: Programmable Interface Controller  
PIR: Passive Infra Red  
PN9: 9-bit Pseudo-random  
RAM: Random Access Memory  
ROM: Read Only Memory  
RF: Radio Frequency  
RFID: Radio Frequency Identification  
RSSI: Received Signal Strength Indication  
RTC: Real-time Clock  
RTF: Reader-Talks-First  
RX: Receive, Receive Mode  
SCLK: Serial Clock

SCK: Serial Clock  
SDI: Serial Data In  
SDO: Serial Data Out  
SI: Serial In  
SO: Serial Out  
SMA: Subminiature version A  
SMD: Surface Mount Device  
SOIC: Small Outlined Integrated Circuit  
SPI: Serial Peripheral Interface  
SRD: Short Range Devices  
SS: Slave Select  
SSPBUF: Serial Receive/Transmit Buffer  
SSPSR: MSSP Shift Register  
TTF: Tag-Talks-First  
TX: Transmit, Transmit Mode  
UHF: Ultra High Frequency  
USART: Universal Synchronous and Asynchronous Receiver Transmitter  
USB: Universal Serial Bus  
VCC: Collector Common Voltage  
VCO: Voltage Controlled Oscillator  
VSWR: Voltage Standing Wave Ratio  
WOR: Wake on Radio  
WSN: Wireless Sensor Network

# CHAPTER 1

## INTRODUCTION

### 1.1 Overview of Radio Frequency Identification and Wireless Sensor Network

The ubiquitous computing was first envisioned as the third wave of computing by Mark Weiser (1991). The vision now is called pervasive computing, which emphasizes that the computing capacity will be embedded into the environment and everyday object (Estrin *et al.*, 2002). Pervasive computing devices are very tiny, either mobile or embedded in almost any type of object which communicates through interconnected networks. Radio frequency identification (RFID) and wireless sensor network (WSN) are two important components of pervasive computing since both technologies can be used for coupling the physical and the virtual world (Lei and Zhi, 2006).

Wireless sensor has been making a significant impact to the human daily life. Wireless sensors are the key that enables the technology for emerging cyber-physical systems, which will ultimately improve the quality of life. Wireless sensor is also known as wireless sensor node or sensor node. WSN consists of spatial distributed sensor nodes that cooperatively sense and may control the environment enabling interaction between persons or computers and the surrounding environment (Shah and Kumar, 2007). WSN technology has the capability for quick capturing, processing, and transmission of critical data in real-time. Typical hardware platform of wireless sensor node consists of sensor, microcontroller, radio frequency transceiver and power source. The WSN nodes microcontrollers are reprogrammable. This enables easier modifications to suit application requirements. The sensor nodes

are used for sensing temperature, humidity, pressure, vibration intensity, sound intensity and pollutant levels. WSN is widely used for environment monitoring, distributed surveillance, healthcare and control applications (Estrin *et al.*, 2002).

RFID is a method of remotely storing and retrieving data using devices called RFID tags. The function of RFID system is similar to the barcode system in terms of identifying the items or objects. Besides, the user can locate the position of the tag by identifying the reader location. The tag will be detected by the reader if the tag is in the reader's interrogation zone. Recently, RFID has become popular as an alternative to the identification and tracking solution over the barcode. The RFID applications can mainly be found in inventory management, asset tracking, object location, retail, healthcare, automotive and textile. Wal-Mart, the United States Department of Defense, the Food and Drug Administration, Marks and Spencer, Tesco and Gillette are some of the first pioneers (Sarac *et al.*, 2008). In 2003, Wal-Mart and the United States Department of Defense announced that they will be using RFID tags for pallets and cases in conducting business with their major suppliers (Lin *et al.*, 2006). Through this mandate, RFID applications in supply chains increased considerably.

The RFID tag gives a unique identification to the object that the tag is attached to. However, it does not provide information about the condition of the object it detects. Sensor, on the other hand, provides information about the condition of the object and its environment. Therefore, with the integration of RFID and WSN technology, their disadvantages can be overcome and their advantages can be put to some important applications.

## **1.2 Research Motivation**

The reports of stolen property are common. High value assets in museum, private collections, automated teller machine (ATM) box and jewellery stores are some items targeted by thieves. Property loss due to theft can be reduced if the attempt to remove the asset is detected at once. Hence, it is appropriate to develop a RFID-based anti-theft system as a solution. The proposed system is functioning such that when the tag which is attached to the asset senses the tampered event, it will immediately send the alert signal to the RFID reader. Upon successfully receiving the alert signal, the reader will turn on the LED to alert the user and pass the information to the host computer for data logging. With immediate alert from the tampered item, the user may have enough time to react before the stolen item is going out of sight.

## **1.3 Thesis Objectives**

The aim of this project is to develop 433 MHz active RFID system prototype components that comprised of RFID tag and RFID reader. The objectives of the research work are outlined as follows:

1. To design RFID tag that has the capability to detect movement of the object that is attached to it, sends data in a real-time and consumes low power at minimum 2 years lifetime.
2. To implement the proposed 433 MHz active RFID system for real-time application.
3. To analyze the performance of the prototype 433 MHz active RFID system in the real-world environment.



## **1.4 Requirements**

These are the requirements of the project.

1. Each tag shall be integrated with motion sensor and powered by the battery.
2. The RFID tag will have the capability to determine if the tagged object is either in motion or stationary.
3. The read range has to be at least 10 meters.
4. The RFID system has to be operated in 433 MHz frequency range as conformance to ISO-18000-7 standard.

## **1.5 Research Methodology**

The development of this project has been separated into two parts. The first part focuses on the design and development of prototype RFID tag and RFID reader which includes the devices selection, hardware architectures design, schematic diagram design, printed circuit board (PCB) layout design, PCB fabrication and components assembly. The second part comprises the software design and development for RFID tag and RFID reader. The design and development of hardware and software are executed side by side as the debugging process requires both parts to be ready. The implementation of proposed ultra high frequency (UHF) active RFID system is realized in the real-time application, which in this case is anti-theft system. The completed prototype RFID system are analyzed and tested in real-world environment to ensure the entire objectives are successfully accomplished. The methodology followed throughout this project is illustrated in Figure 1.1.

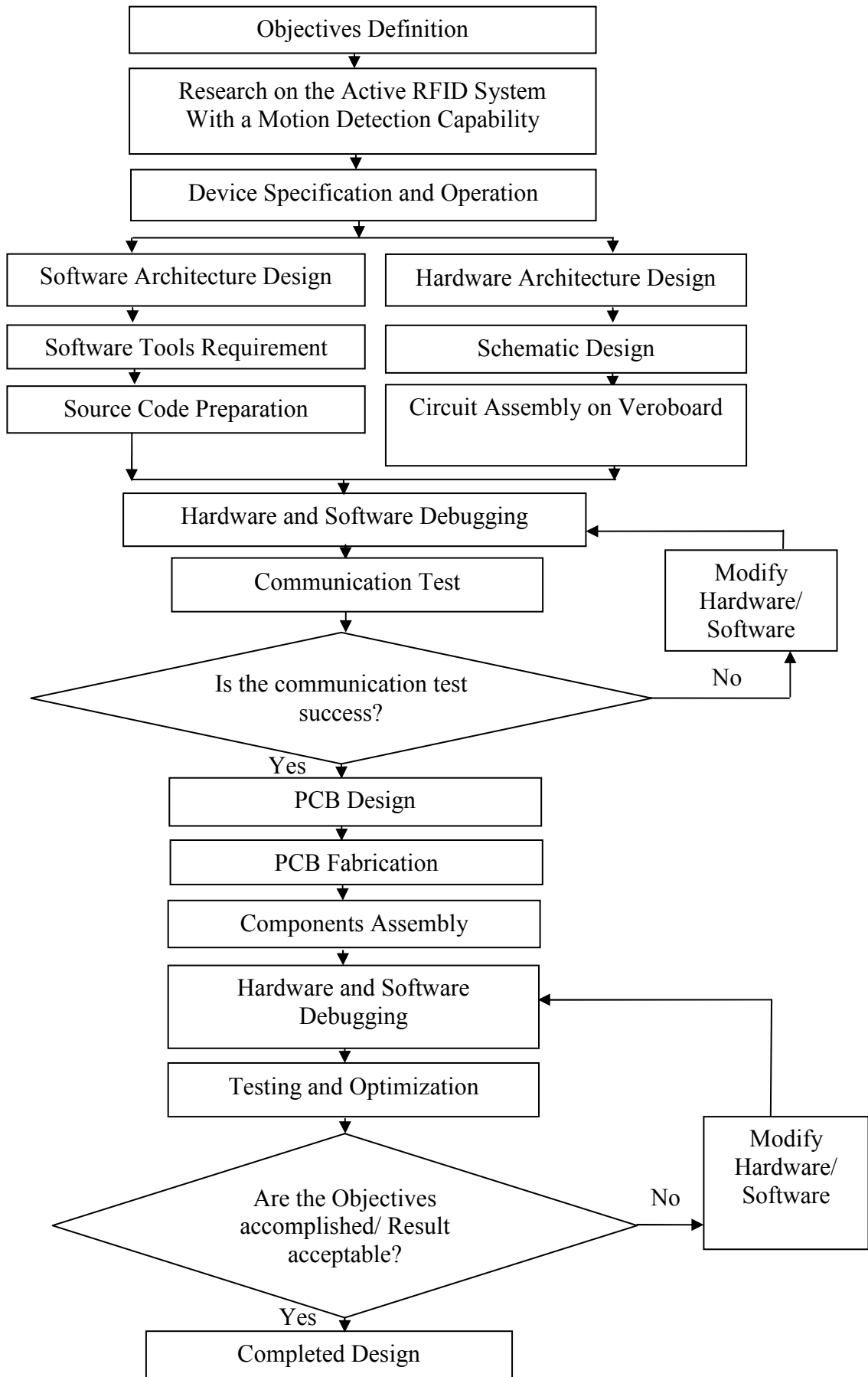

Figure 1.1: Design methodology flow chart

## **1.6 Thesis Outline**

The thesis report has been organized into seven chapters as follows. The literature review is presented in Chapter 2. The survey on key components, anti-collision algorithms, communication protocols and 433MHz air interface standard are included. Chapter 3 describes the specification and operation of the key components used in the project. Chapter 4 demonstrates the detailed aspects of hardware development and implementation which begins with the construction of prototype RFID components on veroboard. The details of PCB design which include the schematics, PCB layouts, component lists, PCB fabrication and final result of prototype RFID components are presented. Chapter 5 presents the software development and implementation for the proposed RFID system. The algorithm of RFID tag and RFID reader are presented. Each of the important functions such as devices configuration, transmit, receive, motion sensor signal processing, motion detection algorithm and anti-collision method are described. Chapter 6 presents the results and discussion of the testing that have been conducted on the prototype RFID system. The final chapter provides the conclusions and suggestions for future work that can be realized for this project.

## CHAPTER 2

### LITERATURE REVIEW

#### 2.1 Introduction

Although RFID became known to many only in the recent years due to the widening of its applications, the concept of RFID has actually existed decades ago. In 1896, Guglielmo Marconi demonstrated the successful transmission of radio signals across the Atlantic. Since then, radio waves have been an important way to send messages. The big practical RFID application was traced back in the World War II. In 1935, Sir Robert Alexander Watson-Watt led to the development of an “Identify Friend or Foe (IFF)” system using radar. The IFF system was used in the war to detect and differentiate between the friendly and the enemy aircrafts. Friendly aircrafts would transmit a signal back upon receiving a signal from a ground radar station for identification. Parallel to these developments, Harry Stockman of the US Air Force Material Command published a paper entitled “Communication by Means of Reflected Power,” in which he outlined basic concepts of what would eventually become the RFID (Landt, 2005).

The wide usage of the technology was made possible only in the late 1980s and 1990s when semiconductor companies were able to improve performance with size and cost reductions (Landt, 2005). Recently, the RFID is widely used in asset tracking, supply chain management, animal tracking, automatic toll collection, healthcare management and access control (Das, 2005).

## **2.2 Components of RFID System**

An RFID system is always made up two components:

- the RFID tag, which located on the item to be identified.
- the RFID reader, which depending upon the design and the technology used, maybe a read or write/read device.

### **2.2.1 RFID Tag**

RFID tag is also known as transponder. It has an identification number and a memory that stores data related to the tagged item. The tag can either be passive or active. A passive RFID system is illustrated in Figure 2.1. The passive tag does not have an internal power source. It is composed of silicon chip that comprise basic modulation circuitry and non-volatile memory, as well as an antenna coil. Passive tag derives all the power for operation from the reader field. The system operates in the following way. The reader emits a signal at a fixed radio frequency. When a tag comes within the reader's field, the tag powers up and transmits the data to the reader by backscattering part of the energy it received (Krishna and Husalc, 2007). By detecting the backscattering signal, the information stored in the tag can be fully identified. The backscattering signal is weak which limit the operating range of the passive RFID system. Furthermore, conventional passive RFID tags are somewhat limited in capability.

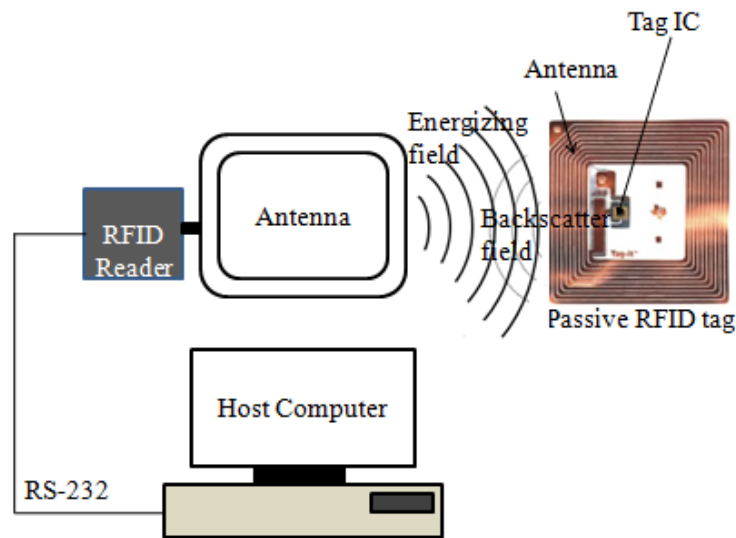

Figure 2.1: Passive RFID system

Active tags have internal power source which is used to power any integrated circuits that generate the outgoing signal. Because of the larger power available, the active RFID tag has greater communication range compared to the passive tag. Yoon *et al.* (2008) designed an active tag using Atmel microcontroller (ATmega128L), a Chipcon RF transceiver (CC1020) and other components as shown in Figure 2.2. A transceiver and microcontroller are two dominating components of conventional active RFID tag.

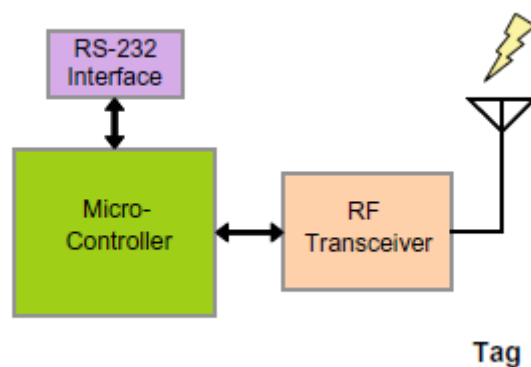

Figure 2.2: Block diagram of an active RFID tag

Active tags are capable of establishing a connection with a reader independently hence more reliable than the passive tags. It also can support additional functions such as data storage and sensing capability. Table 2.1 shows the summary of characteristics of passive and active tag (Stanczak, 2007).

Table 2.1: RFID tag attributes

	Passive RFID	Active RFID
Tag power source	Energy transferred using RF from the reader	Internal to tag
Tag battery	No	Yes
Availability of power	Only in the field of reader	Continuous
Required signal strength	Very high	Very low
Signal strength from tag to reader	Low	High
Range	Up to 3-5 m, usually less	Up to 100 m
Data storage	128 Bytes of read/write	Up to 128 kBytes or read/write with sophisticated search and access

A number of researches have been conducted to enhance the functionality of the RFID tags in term of providing crucial information such as movement condition of the assets. Gilbert *et al.* (2008) have designed a tamper monitoring system which includes one RFID tag and a transmission link. The tag consists of an optic transmitter and receiver. The first end of the transmission link is connected to the transmitter and the second end to the receiver. The communication link is a fiber optic cable. The transmitter transmits a varying signal through the transmission link to the receiver, and the receiver receives a signal from the transmission link. The tamper event is detected by comparing the receiver received signal with the average of previously received signals, and when the difference between the received signal

and the average is greater than a predetermined value, the tag transmits a tamper beacon to the reader.

Armstrong and Viejo (1995) have invented RFID tag comprises two tag chips, an antenna, and a sensor switch which is placed in between the tag chips. Each of the tag chips is programmed with the same data except one bit. This one bit is used to determine the condition of the tagged item. The sensor switch is acted as a single pole relay. When the sensor switches at normally closed position, it connects the first tag chip to an item, while at normally open position it connects the second tag chip to the item. In each switching position, the tag transfers the same information except one bit that represents either 'high' or 'low'. This information can be used to sense the condition of tagged item such as a pressure or tamper event. This method requires two tag chips on a single tag hence will consume high current.

Tuttle and Corrales (1997) have designed an active RFID tag to detect the unauthorized opening of containers and baggage. The circuitry of the tag composed of trip-wire, dipole antenna and integrated chip which has transmitter, memory logic and receiver. The trip-wire associated with a shipping container provides continuity across all nodes and RFID tag. If continuity of the trip-wire is disrupted, RFID tag would then send signal to the RFID reader to alert the owner or monitoring station. However, one can place a bypass connection, and then cut the wire with the system not detecting a tamper event.

Arshak and Adepoju (2007) used radio frequency sensor which composed of two transceivers to estimate the real-time position of a moving object. One of the transceiver is connected to the personal computer via an RS232 connector and the other one is affixed on the object. The moving object which is attached to the transceiver continuously transmits a signal to the receiver that is connected to



personal computer. The signal strength obtained at receiver is used to determine the correct location of the corresponding object. Then, the received signal strength indicator (RSSI) value from the receiver is downloaded to the PC. Custom algorithm runs on PC processed the RSSI value in order to produce the real-time position data. It is found that the accuracy of detecting a moving object position using this method is influenced by a couple of antenna, receiver and transmitter related factors. The RSSI measurements are prone to noise and interference, which leads to error in localization [Kumar *et al.*,2009].

One of the issues in developing an active RFID system is to maximize the lifetime of the active RFID tags. Because an active tag is powered by internal energy, the lifetime of the tag is mainly depended on the lifetime of the battery. For power saving mechanism, one should design the mechanism such that the processor can completely turned off the radio or simply put it in sleep mode . Cho and Baek (2006) presented the design and implementation of 433 MHz active RFID system. The design focused on the energy saving mechanism to maintain the longevity of tags as long as possible. The RFID tag design architecture is composed of the Atmel's Atmega128L microcontroller, XEMIC's XE1203 RF transceiver and real-time clock. Slotted Aloha collision arbitration mechanism is implemented to perform an efficient and orderly collection of the tags. By using a pair of AA batteries with a capacity of 2500 mAh, assuming the system will operate uniformly over the deployment period, the current consumption of the tag is 0.30876 mA per hour. Therefore, the lifetime of the tag is about 1 year by using 2 AA 2500 mAh batteries.

### 2.2.2 RFID Reader

The RFID reader, also called the interrogator, is a device which wirelessly communicates to the tags in its communication range. The reader controls the protocol, read information from the tag, directs the tag to store data in some cases and ensures message delivery and validity. The reader emits radio waves via antenna. Some readers have only one antenna, while other readers are able to support many antennas which can be placed at different locations. Readers communicate with host computer and other devices through a variety of interface such as RS232, Universal Serial Bus (USB) and Bluetooth. An active RFID reader with a simple architecture is shown in Figure 2.3 (Yong *et al.*, 2008). The reader's microprocessor directly controls the RF transceiver in communicating with the tags and processes all the tasks, such as the communications protocol and tag response data. These processing tasks are serialized.

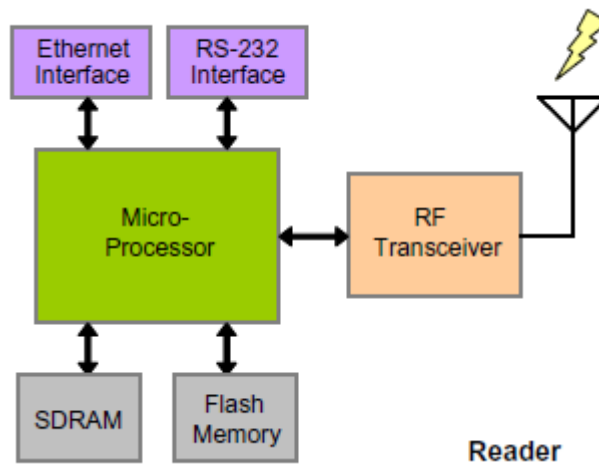

Figure 2.3: Simple architecture of an active RFID reader

The architecture of RFID reader from Figure 2.3 was further modified to improve the tag collection performance as shown in Figure 2.4 (Yoon *et al.*, 2008). The reader's microprocessor controlled the RF transceiver in communicating with the tags,

handled communications protocol and processed tag response data. An additional controller has been used to enable the microprocessor and RF transceiver to perform the individual tasks in parallel.

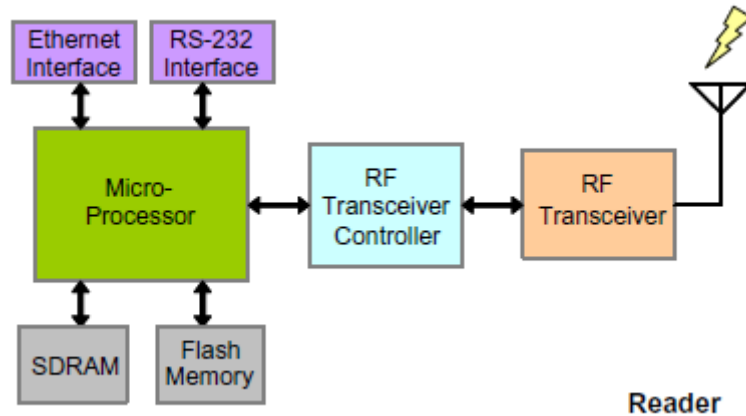

Figure 2.4: Improved architecture of an active RFID reader

Kumar *et al.* (2009) has demonstrated the design of high end low cost UHF RFID reader using three modules viz. power supply, microcontroller and transceiver. A 32 bit ATMEL's AT91SAM7S256 with ARM7 core microcontroller is used to support total firmware of the system which includes the boot up, the mode of operation and the registers configuration. All the data and commands are sent and received through 20 MHz Serial Peripheral Interface bus. The transceiver module contains major components such as Intel R1000 chip, balun and dielectric band pass filter. The R1000 chip incorporates the complete transmit, receive, modulation, demodulation and baseband functions into one chip. This reader has multiple voltage regulator circuits to supply voltage to different subsystems. For example, 1.8 V and 3.3 V to the microcontroller board and transceiver board, and 5 V to the receiver section of Intel R1000 transceiver.

## **2.3 Review of Motion Sensor Technologies for RFID Tag**

The goal of this section is to provide better understanding to the existing technologies of motion sensor since the external motion sensor will be integrated to the proposed RFID tag. The key selection criterion is based on the capability of the sensor to detect its body motion.

### **2.3.1 Passive Infra Red Sensor**

A Passive Infra Red (PIR) sensor is an electronic device which measures infrared light radiating from objects in its field of view. The name passive in PIR sensors means that the device does not give off infrared rays, but rather it just collects them from other objects (Repas, 2008). The infrared part of the name refers to the infrared rays that an object radiates and the sensor collects. When a human passes in front of a PIR sensor, the sensor picks up on the temperature difference between the person and the background, such as the wall. The PIR sensor reacts to this change in infrared energy and provides a low-frequency, small amplitude signal hence it is an analog sensor. In sensor alarm system, the sensor detects the intruder by analyzing the amplitude and change rate of an electric output signal of PIR sensor (Kastek *et al.*, 2007). PIR sensor is an analog sensor that requires supporting circuitry, resistors and capacitors in its operation.

### **2.3.2 Microwave Motion Sensor**

Microwave motion sensors are used in wide range of applications such as intrusion detection system, automatic door system and light activation system to detect human movement (Otero, 2005). Microwave motion sensors are continuous wave radars that utilize the Doppler Effect to produce a signal that is proportional to

the velocity of the moving target. A paper by Ju *et al.* (2007), describes the design of 2.4 GHz RFID system that utilized microwave motion sensor for security system. The designed RFID system comprises microwave motion sensor, web camera, RFID tag and RFID reader, which communicate with the host computer via Bluetooth. The microwave motion sensor is incorporated to the immobile RFID tag. The sensor detects the moving object by comparing the radiated wave with the returned wave. The difference between radiated wave and returned wave is linear variance in the whole frequency. When the movement is detected, the tag transmits the signal to the reader to enable the system. Concurrently, the camera captures the image of moving target at the area directed by RFID tag.

### **2.3.3 Accelerometer**

Accelerometer is a device for measuring acceleration and the effects of gravity. The magnitude and direction of acceleration are measured either in a single-axis or multi-axis. Accelerometers are useful in sensing orientation, vibration and shock in the objects. The accelerometer bandwidth determines the measurement resolution. The resolution is referred as the smallest detectable increment in acceleration. The output of the accelerometer can be either digital or analog voltage that is proportional to acceleration. Digital output can directly be read via serial interface such as I<sup>2</sup>C and SPI. While, analog output requires an analog-to-digital converter to translate the signals to digital data. It is often necessary to calibrate the accelerometer to set the 0 g-offset to store the known offset voltage value when there is no motion or gravity acting on the accelerometer. Accelerometers have been used in human caring system to recognize human activities for the elderly care monitoring purposes (Im *et al.*, 2008). Besides, accelerometers also have been used in military

and scientific applications including inertial navigation, vehicular safety systems such as airbags, tilt sensing, and vibration monitoring.

### 2.3.4 Vibration Sensor

The sensor has two pieces of metal called contacts that touch to make a circuit, and separate to break the circuit. A mechanism of the sensor for detection movement is based on the ball displacement inside the housing. The ball can be mercury or non-mercury metals. The vibration sensor that uses mercury ball is made up of two electrical contacts and a ball of mercury positioned inside a cylinder. Mercury is a liquid metal. The liquid metal connection is unaffected by dirt and oxidation. It wets the contacts ensuring a very low resistance bounce-free connection, movement and vibration that do not produce a poor contact. The electrical contacts can be either connected or broken by the movement of the mercury as shown in Figure 2.5 (Michael, 1998). This type of vibration sensor is also known as mercury switch.

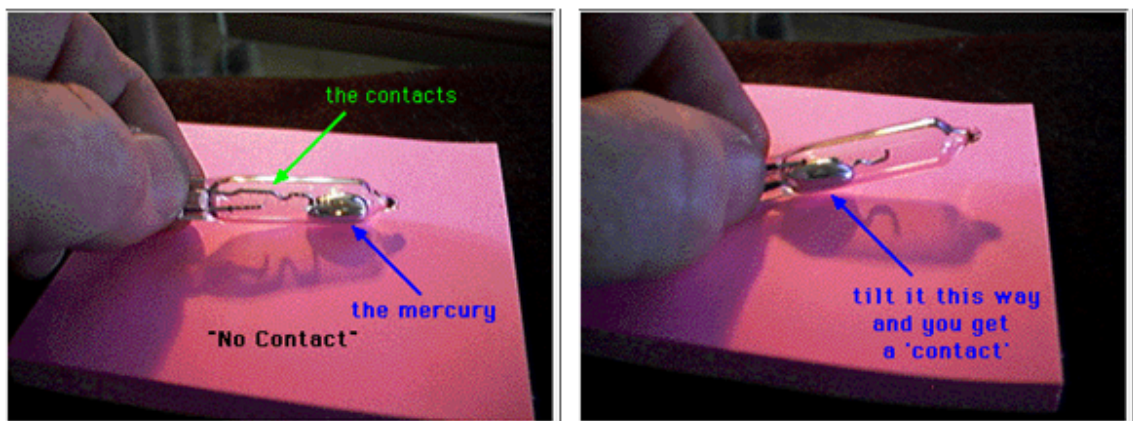

Figure 2.5: Mercury based vibration sensor

The vibration sensor that consists of a few non-mercury balls is also known as the ball switch. The non-mercury balls are acted as a switch. The switch can either be opened or closed depending on the balls position. This type of sensor produces binary output. When it is subjected to motion, the switch will continually change state as long as it remains in motion. The conceptual side view of the non-mercury based vibration sensor can be seen in Figure 2.6 (Comus International, 2001).

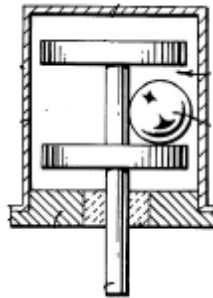

Figure 2.6: Side view of non-mercury based vibration sensor

The wearable monitoring system to recognized human activities is developed using ball switch-based platform (Laerhoven and Gellersen, 2004). In the same project, they developed the same wearing monitoring system but using the accelerometer-based platform. It is found that the ball switches are easier to interface with microcontroller, do not need analog-to-digital conversions and having low power requirement compared to accelerometers. The accelerometers, on the other hand, have a higher resolution for orientation and their signals produce direct motion patterns. The result shows that wearable system of accelerometer-based platform recognize very well on all activities such as standing, lying down, kneeling, sitting, walking and bicycling. However the combination of ball switches in embedded sensor is competitive with accelerometers, especially regarding power consumption.

## **2.4 RF Transceiver for the Proposed RFID System**

In radio terminology, the transceiver contains both a receiver and a transmitter. In this project, the off-the-shelf RF transceiver module will be used rather than a chip, as implementing an RF design can be complicated by RF module physical assembly technology, surface mount assembling machine and the requirement of government agency approvals (regulations and licensing) (Ulrich, 2006). Besides, RF transceiver modules are available with small footprints, versatility to match most requirements and available pre-certified for immediate embedment into an end product. In Malaysia, the employment of radio frequencies has to comply with the Malaysian Communications and Multimedia Commission (MCMC) regulations.

The 433 MHz RF transceivers are available from several manufactures, including Analog Devices, Nordic Semiconductor, and Texas Instruments. RF transceivers are commonly used in RFID and Wireless Sensor Network application. The RF transceiver selection is application-dependent (He and Flikkema, 2009). A summary of the manufacturer's specifications for the considered RF transceivers to be used in the project is shown in the Table 2.2. Among these transceivers, CC1100 provides the highest data rate and many useful features which are required for the development of the software of the proposed RFID system. The CC1100 uses less current during transmission, a potential advantage in applications where energy efficiency is paramount (He and Flikkema, 2009). Hence, this transceiver will be used in the project.



Table 2.2: Summary of manufacturer's specifications of RF transceiver

Feature	nRF905 (Nordic Semiconductor, 2005)	ADF7020 (Analog Device, 2006)	CC1020 (Texas Instrument, 2008)	CC1100 (Texas Instrument, 2006)
Supported Modulation Formats	GFSK	BFSK, GFSK,OOK, ASK	OOK, FSK, GFSK	BFSK,GFSK, MSK,OOK, ASK
Data Rate	100 kbps	0.15-200 kbps	Up to 153.6 kbps	1.2-500 kbps
Sensitivity @ 1.2 Kbps	-100 dBm	-119 dBm	-118 dBm	-111 dBm
Output Power	10 dBm	13 dBm	10 dBm	10 dBm
TX Current	30 mA	28 mA	27.1 mA	28.9 mA
RX Current	12.5 mA	21 mA	19.9 mA	15.2 mA
Power down current	2.5 $\mu$ A	0.1 $\mu$ A	0.2 $\mu$ A	0.4 $\mu$ A
Number of External parts (typical)	17	34	15	26
Other features	Carrier Detect, Address Match, Data Ready, Auto Retransmit	Digital RSSI	Digital RSSI, Carrier Sense Indicator	Digital RSSI output, Sync Word Detect, Address Match, Flexible Packet Length, Automatic CRC Handling, Programmable Carrier Sense, Optional Automatic Whitening and Dewhitening of data, Link Quality Indication

## 2.5 Microcontroller for the Proposed RFID System

In this project, the data processing algorithm is carried out by the microcontroller. The microcontroller acted as the brain for the tag and reader. The tag will be powered by onboard battery. A low power and general purpose

microcontroller is sufficient enough to be used in this project development. A microcontroller is a type of microprocessor emphasizing high integration, low power, self-sufficiency and cost effectiveness, in contrast to general-purpose microprocessor (the kind used in PC). The microcontroller typically integrates additional elements such as read-write memory for data storage, read-only memory, such as flash for code storage and EEPROM for permanent data storage. At clock speeds of as little as a few MHz or even lower, microcontrollers often operate at very low speed compared to modern day microprocessors, but this is adequate for typical applications. Power consumption used by microcontroller while inactive maybe just nanoWatts, making them ideal for low power and long lasting battery applications (Ivey, 2002). The few criteria used in selecting microcontroller for this project are low power consumption, ability to communicate serially with other peripheral devices, has external interrupt pins, has at least 32 kBytes program memories and operate on 3 V supply voltage. The microcontroller must have USART and SPI peripheral for interfacing with RF transceiver, real-time clock and the host computer that will be used in the design. The microcontroller must have two external interrupts to be connected to the motion sensor and real-time clock alarm. Meanwhile, large memory allocation is required for RF communication and real-time application implementation.

The 8051 microcontroller was introduced by Intel in 1980 as an improvement over its predecessor the 8048 microcontroller. It was widely used and one of the most popular microcontrollers in the 80s and 90s. The typical features of 8051 microcontroller are a 4 kBytes program memory, programmable I/O ports, timers, counters and serial data communication. The 8051 is also a low-power consumption microcontroller hence it is suitable for battery-powered devices. Over the years, companies such as Atmel, Infineon Technologies, Maxim Integrated Products via its

subsidiary company Dallas Semiconductor, NXP formerly known as Philips Semiconductor, Winbond, ST Microelectronics, Silicon Laboratories formerly known as Cygnal, Texas Instruments and Cypress Semiconductor have manufactured and provided a broad range of 8051 based microcontrollers. Several C compilers are available for the 8051, most of which feature extensions that allow the programmer to specify where each variable should be stored in its six types of memory, and provide access to 8051 specific hardware features such as the multiple register banks and bit manipulation instructions. Other high level languages such as Forth, BASIC, and Pascal are available for the 8051, but they are less widely used than C and assembly.

Programmable Interface Controller (PIC) is a Harvard architecture based microcontroller developed by Microchip Inc. Typically, PIC is an 8-bit microcontroller with RAM data memory, ROM or flash program memory, digital I/O ports, timers and external clock interface. PIC is one of the most popular microcontrollers among the developers and hobbyist due its low cost and wide range of availability. Microchip provides the C Compiler for PIC18 with unlimited code size. This facility is also available for other PIC family.

PIC microcontroller has been used in many embedded projects such as digital display system for Ionic Sensitive Field Effect Transistor (ISFET) pH sensor (Hashim and Haron, 2009). In this project, the PIC with a built-in ADC is used to analyze the analogue input from ISFET pH sensor and display the digital output on the LCD. The pH sensor communicates with the PIC via serial link. A paper written by Laerhoven and Gellersen (2004) demonstrates the development of an interface circuit for embedded sensor to recognize a person's motion and pose using PIC18F452. A total of twenty embedded sensors have been distributed in the

garment. With the PIC maximum clock speed of 40 MHz, the core unit is able to read all accelerometers values via serial port in high-speed. The PIC18F452 microcontroller operates at 5 V supply and has 40 pins. The smaller version of this microcontroller is PIC18LF252 which operates at 3 V supply and has 28 pins. This PIC is an upgrade of the earlier PIC16C74 and PIC16F877 microcontroller.

The microcontroller from Atmel AT89C51RC2 (Atmel, 2006) and Microchip PIC18LF252 (Microchip, 2002) specifications fulfill the requirements needed for this project. Table 2.3 shows the comparison between these microcontrollers' specifications.

Table 2.3: Comparison between AT89C51RC2 and PIC18LF252 specifications

	Atmel AT89C51RC2	Microchip PIC18LF252
<i>Features</i>		
Program Memory (Bytes)	32 k	32 k
Operating Range	2.7-3.6 V	2.0-5.5 V
External Interrupt Pins	2	3
Timers	3	4
Serial Communication	SPI,USART	SPI,USART
Power Down Current @ 4 MHz	50 $\mu$ A	4 $\mu$ A
Active Mode Current @ 4 MHz	6.6 mA	1.25 mA
Packages	PDIL40 PLCC44 VQFP44	28-pin DIP 28-pin SOIC

Between these two microcontrollers, PIC18LF252 has the lowest current consumption in power down and active mode, which is essential in designing low power RFID tag. Hence, this microcontroller is selected for this project.

## **2.6 Radio Frequency Communication Protocol**

Tags and readers communicate by using a common communication protocol. Tag-Reader communication can be initiated in two ways; Reader-Talks-First (RTF) or Tag-Talks-First (TTF).

### **2.6.1 Reader-Talks-First Protocol**

The ISO 18000-7 standard suggests RTF protocol in 433 MHz communication (ISO/IEC 18000, 2004). It is also identified as one of the solutions for multiple tags collision, which is found by establishing two way communication links between the tag and the reader (Rohatgi and Durgin, 2006). Using this two way communication link configuration, the reader queries the tags within its interrogation zone. A tag does not transmit data, unless it has received and properly decoded a reader command. This means that the tags only transmitted the data in respond to the reader command.

### **2.6.2 Tag-Talks-First Protocol**

An active tag has the ability to initiate the communication with the reader by transmitting its identification as soon as it enters the reader's interrogation zone because it has onboard power supply. The reader then responds by transmitting an acknowledgment signal. This type of protocol is called Tag-Talks-First which is implemented in Aloha algorithm (Tang and He, 2007).

## 2.7 Anti-collision Algorithms

Tag collisions arise when more than one tag respond simultaneously to a reader's request, as shown in Figure 2.7. This causes data collisions at the reader, leading to bandwidth and energy wastage, and prolonged tag identification time (Finkenzeller, 2003). Therefore, anti-collision protocols which could reduce data loss due to collision regardless of the occurrence of collision are required in the proposed RFID system.

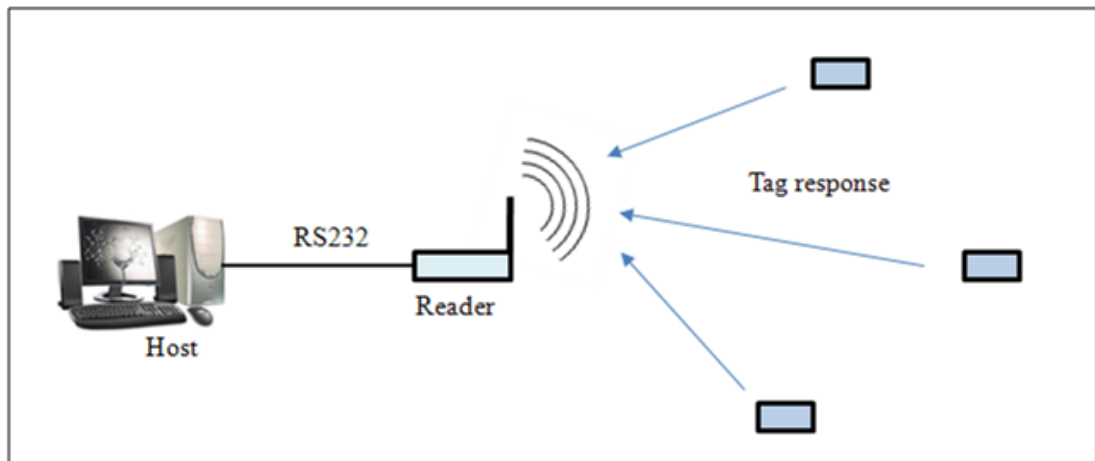

Figure 2.7: Interactions between a reader and tags

Various approaches exist in anti-collision algorithms. The Aloha algorithm is one of the popular methods to solve the data collision problem due to its efficiency and practicability (Gou *et al.*, 2007). Aloha was developed in the 1970s for a packet radio network at the University of Hawaii (Abramson, 1985). The destination (receiver) will find out whether the transmission is successful or experienced a collision by listening to the broadcast. If there is a collision, the source will retransmit the data after a random waiting period. This protocol involves the simplest of all reader designs where the reader just listens. The tags periodically send data packets at the random periods. Due to the probabilistic behavior of this protocol,