

DESIGN OF WIDEBAND RF FRONT END WIRELESS TRANSCEIVER

By

IHSAN BIN AHMAD ZUBIR

**Thesis submitted in fulfillment of the requirements
for the degree of
Master of Science
in Electrical and Electronics Engineering**

February 2012

In The Name of Allah SWT the Most Gracious and The Most Merciful

“If Allah helps you, none can overcome you: if He forsakes you, who is there, after that, that can help you? In God, then, let believers put their trust.”

(Al-Quran, Al-Imran: 160)

Alhamdulillah. I praise and glorify be only to **Allah SWT** the Almighty, the Most Beneficent and the Most Merciful, whose blessings and guidance have helped me through my study and my life smoothly. There is no power, no strength save in **Allah SWT** the Highest, the Greatest. Peace and blessing of **Allah SWT** be upon to **Rasulullah Muhammad SAW**, who has given light to all mankind in the world.

DEDICATION

This thesis is dedicated to:

My Father, Ahmad Zubir bin Abdul Rani, and my mother Laily Fauziah binti

Hashim thanks for all of their love, lots of cares and happiness.

My beloved brothers and sisters for their support and happiness over the entire period of my study.

Acknowledgements

First of all, I want to express my most sincere thanks to my supervisor, Assoc. Prof. Dr. Mohd Fadzil Ain with my deepest gratitude. He has been an inspiration to me since I first met him. His energetic style and never ending flow of ideas has been a model in my academic and personal life. I also want to thank him for trusting in me and encouraging me to pursue this adventure, his moral support during the two years of my program has been fundamental to the conclusion of this lifelong dream. His guidance during the development of my research has been invaluable.

I would like to thank Mr. Elias and Mr. Mohd Zuber, PCB lab technicians, for helping me in layout and fabrication of PCB. Thanks are also extended to Mr. Abdul Latip and Mr. Ahmad Ahzam, Communication lab technicians for their kind assistance and cooperation in conducting the research. I enjoyed working in the Communication Lab at Universiti Sains Malaysia during my Master study. All our group members were extremely helpful. I learned a lot from them. I would also like to thank them for their support and valuable group discussions.

I am greatly indebted and appreciate very much to my parents, Ahmad Zubir bin Abd. Rani and Laily Fauziah binti Hashim for their encouragement, support and sacrifices throughout the study. To all my dearest brothers and sisters, a big thank you for their support and encouragement and for putting colours in my life, may Allah bless you all.

Table of Contents

Dedication	ii
Acknowledgements	iii
Table of Contents	iv
List of Figures	vii
List of Appendices	x
List of Tables	xi
List of Abbreviation	xii
ABSTRAK	xiii
ABSTRACT	xv
CHAPTER 1 - INTRODUCTION	
1.1 Background	1
1.2 Motivation	3
1.3 Problem Statement	5
1.4 Objectives	6
1.5 Thesis Outline	7
CHAPTER 2 - LITERATURE REVIEW	
2.1 Introduction	8
2.2 RF front end wireless transceiver	9
2.3 Bandpass filter	11
2.3.1 End-coupled structure	12
2.3.2 Split-ring resonator structure	13
CHAPTER 3 - THEORETICAL STUDY	
3.1 Introduction	15
3.1.1 Visual Sensor	16
3.1.2 Microcontroller	17
3.1.3 Front End Transceiver	17
3.2 Microstrip Transmission Line	18
3.3 Transceiver	20
3.4 Transmitter	21
3.4.1 Heterodyne Transmitters	23
3.4.2 Direct Upconversion Transmitters	24
3.5 Receiver	25
3.5.1 Superheterodyne receiver	26

3.5.2	Direct Conversion Receiver	28
3.5.3	Low-IF receiver	31
3.5.4	Wide-Band IF receiver	34
3.6	Upconverter	36
3.7	Downconverter	37
3.8	Power Amplifier	41
3.9	Low Noise Amplifier	42
3.10	Local Oscillator	43
3.11	Multiplier	45

CHAPTER 4 - WIRELESS TRANSCEIVER DESIGN FOR IMAGE TRANSCEIVER

4.1	Introduction	47
4.2	Simulation and fabrication software	48
4.2.1	Advanced Design System (ADS)	48
4.2.2	Computer Simulation Technology (CST)	49
4.3	Printed Circuit Board	51
4.4	Transmitter Design	52
4.4.1	Upconverter	53
4.4.2	Power amplifier (HMC311ST89)	54
4.4.3	IF Amplifier (Gali 74+)	56
4.4.4	Voltage Control Oscillator	58
4.4.5	Multiplier	59
4.4.6	5.8 GHz Bandpass filter	61
4.4.7	Complete transmitter	67
4.5	Receiver design	68
4.5.1	Low noise amplifier (HMC320MS8G)	69
4.5.2	Downconverter	70
4.5.3	132 MHz Bandpass filter	71
4.5.4	Complete receiver	77
4.6	Transceiver design	78
4.6.1	Complete transceiver	81

CHAPTER 5 - RESULTS AND DISCUSSION

5.1	Simulation Result	83
5.1.1	Transmitter Simulation	83
5.1.2	Receiver Simulation	86

5.2	The fabrication of transceiver parts	88
5.2.1	Power amplifier	89
5.2.2	Low noise amplifier	90
5.2.3	Mixer	91
5.2.4	Bandpass filter	92
5.2.4.1	5.8 GHz Bandpass filter	92
5.2.4.2	132 MHz Bandpass filter	93
5.2.5	Voltage controlled oscillator	94
5.2.6	Multiplier	95
5.3	Prototype Performance and Evaluation	95
5.3.1	Power amplifier	96
5.3.2	Voltage controlled oscillator	97
5.3.3	Upconverter	101
5.3.4	Multiplier	102
5.3.5	5.8 GHz Bandpass filter	104
5.3.6	IF amplifier	107
5.3.7	Complete Transmitter	110
5.3.8	Low noise amplifier	112
5.3.9	Downconverter	113
5.3.10	132 MHz Bandpass filter	115
5.3.11	Complete Receiver	120
5.3.12	Complete Transceiver	121
CHAPTER 6 - CONCLUSION AND FUTURE WORK		
6.1	Conclusion	124
6.2	Future Work	126
REFERENCES		128
LIST OF PUBLICATIONS		133
APPENDIX		135

List of Figures

Figure 1.1	Architecture of the RF front-end transceiver	3
Figure 2.1	The configuration of end-couple line BPF, General configuration (a), Equivalent model of BPF (b) and Equivalent model with J-inverter (c)	13
Figure 3.1	Block diagram of wireless network for image transmission	16
Figure 3.2	Microstrip transmission line	18
Figure 3.3	Block diagram of a matching network	19
Figure 3.4	General block diagram of transceiver	21
Figure 3.5	Heterodyne transmitter	23
Figure 3.6	Direct upconversion transmitter	24
Figure 3.7	Superheterodyne Receiver Architecture	26
Figure 3.8	Direct-conversion receiver architecture	29
Figure 3.9	Two different cases of self mixing	31
Figure 3.10	Low-IF receiver	33
Figure 3.11	Wide Band IF Receiver	35
Figure 3.12	Block Diagram of Upconverter	37
Figure 3.13	The configuration of the Broadband Down-Converter	38
Figure 3.14	Single balanced mixer with 90° phase shifting net	38
Figure 3.15	Front-End block of a receiver	42
Figure 3.16	Graphical illustration of VCO	44
Figure 4.1	Flow chart of design and fabrication	50
Figure 4.2	Block diagram of transmitter	52
Figure 4.3	Instrument arrangement to test the performance of upconverter	53
Figure 4.4	Darlington pair using NPN transistors	54
Figure 4.5	Application Circuit of Power Amplifier	55
Figure 4.6	Instrument arrangement to test the performance of power amplifier	56
Figure 4.7	Simplified schematic and pin configuration	57
Figure 4.8	Instrument arrangement to test the performance of IF amplifier	58
Figure 4.9	Instrument arrangement to test the performance of voltage control oscillator	59
Figure 4.10	Instrument arrangement to test the performance multiplier	60
Figure 4.11	Structure of the half split-ring resonator	61
Figure 4.12	Equivalent circuit of the split-ring resonator	61
Figure 4.13	Overall structure of the new split-ring bandpass filter	65
Figure 4.14	Instrument arrangement to test the performance bandpass filter	66

Figure 4.15	Instrument arrangement to test the performance of the complete Transmitter	67
Figure 4.16	Block diagram of Receiver	68
Figure 4.17	Schematic Circuit of Low Noise Amplifier	69
Figure 4.18	Instrument arrangements to test performance of low noise amplifier	70
Figure 4.19	Instrument arrangement to test the performance of down converter	71
Figure 4.20	Ladder circuits for lowpass filter prototypes and it's element definitions. Prototype beginning with a series element	72
Figure 4.21	Bandpass filter circuit	73
Figure 4.22	Instrument arrangement to test the performance of 132MHz bandpass filter	77
Figure 4.23	Instrument arrangement to test the performance of the complete Receiver	78
Figure 4.24	Block diagram of Transceiver	80
Figure 4.25	Instruments arrangement to test the performance of the complete transceiver	82
Figure 5.1	Simulation circuit of Transmitter generated using ADS software	84
Figure 5.2	Output power of RF, LO and IF signals at transmitter	85
Figure 5.3	Simulation circuit of Receiver generated using ADS software	86
Figure 5.4	Output power of RF, LO and IF signals at receiver part	87
Figure 5.5	(a) fabrication circuit of the power amplifier and (b) layout of the power amplifier	89
Figure 5.6	(a) fabrication circuit of the 3 stages power amplifier and (b) layout of the 3 stages power amplifier	90
Figure 5.7	(a) fabrication circuit of the low noise amplifier and (b) layout of the low noise amplifier	91
Figure 5.8	(a) fabrication circuit of the mixer and (b) layout of the mixer	92
Figure 5.9	(a) fabrication circuit of the 5.8 GHz bandpass filter and (b) layout of the 5.8 GHz bandpass filter	93
Figure 5.10	(a) fabrication circuit of 132 MHz bandpass filter and (b) layout of the 132 MHz bandpass filter	93
Figure 5.11	(a) fabrication circuit of the 2.834 GHz VCO and (b) layout of the 2.834 GHz VCO	94
Figure 5.12	(a) fabrication circuit of the multiplier and (b) layout of the multiplier	95

Figure 5.13	Output power of a power amplifier at 5.8 GHz with 5V supply	96
Figure 5.14	Output power of 3 stages power amplifier at 5.8 GHz with 5V supply	97
Figure 5.15	Output power of Voltage controlled oscillator at 2.825 GHz with Vcc at 5.359V and VTune is 5.173V supply	99
Figure 5.16	Output power of Voltage controlled oscillator with multiplier at 5.670 GHz with Vcc at 5.359V and VTune is 5.173V supply	100
Figure 5.17	RF output power of upconverter at 5.8 GHz with -11.1dBm	102
Figure 5.18	Output power of multiplier at 5.6678 GHz with -6.001dBm	104
Figure 5.19	Measured and simulated result of insertion and return loss	105
Figure 5.20	Figure of Return Loss vs. Power (dB)	106
Figure 5.21	Figure of Insertion Loss vs. Power (dB)	106
Figure 5.22	Output power of a amplifier at 132.3 MHz with 2.87 dBm	108
Figure 5.23	Output power of 4 stages amplifier at 132.3 MHz with 12.7 dBm	108
Figure 5.24	Output power of 4 stages amplifier at different input power	109
Figure 5.25	Output power of 4 stages amplifier at 132.3 MHz with 12.27 dBm	110
Figure 5.26	Output power of transmitter at 5.8015 GHz with input power of -20dB at 5.8 GHz	111
Figure 5.27	Output power of LNA at 5.7995GHz with 3V supply	113
Figure 5.28	Output power of down converter at 133.5 MHz with -42.57 dBm	115
Figure 5.29	Schematic Diagram of Bandpass filter	116
Figure 5.30	Physical Layout of Bandpass filter	116
Figure 5.31	Simulated result of the insertion loss	117
Figure 5.32	Simulated result of the return loss	117
Figure 5.33	Measured result of the insertion loss	118
Figure 5.34	Measured result of the return loss	119
Figure 5.35	The fabricated of the bandpass filter	119
Figure 5.36	Output power of receiver at 132 MHz with -35.33 dBm	121
Figure 5.37	Output power of transceiver at 132.3 MHz with -24.83 dBm	123

List of Appendices

Figure A1	Receiver circuit	136
Figure A2	Transmitter circuit	136
Figure A3	Transceiver circuit	137
Figure A4	Measured result of insertion loss and return loss at 5.83 GHz	137
Figure A5	Basic Circuit Diagram for Power Amplifier	138
Figure A6	Passive multiplier structure	140
Figure A7	Function demonstration of a passive multiplier	140
Figure A8	Four-quadrant multiplier basic architecture (a) Using transistors in linear region (b) Using transistors in saturation region	143

List of Tables

Table 2.1	Performance comparison of RF front-end wireless transceiver	9
Table 2.2	Types of filter	11
Table 4.1	The properties of substrate RO4003C	51
Table 4.2	Summary of the prototype Filter Transformations	72
Table 4.3	Element values for Equal-Ripple Filter Prototype ($g_0 = 1, \omega_c = 1, N = 1$ to 10 and 0.5dB ripple)	73
Table 4.4	Generator conductance element values for equal-ripple low-pass filter prototypes at 0.5 dB ripple	74
Table 4.5	Impedance scaling formula	75
Table 4.6	Frequency scaling formula	75
Table 4.7	Lump element value of bandpass filter by using impedance and frequency scaling	76
Table 5.1	Output power of transmitter of each component	85
Table 5.2	Output power of receiver of each component	88
Table 5.3	Voltage controlled oscillator (JTOS-3000+) output power at different tuning voltage	98
Table 5.4	Voltage controlled oscillator (JTOS-3000+) with multiplier output power at different tuning voltage	99
Table 5.5	RF output power at different LO and IF power	101
Table 5.6	Output power level for the multiplier at different input power	103
Table 5.7	Result for the varying the edge gap, i for S11 and S21	107
Table 5.8	Output power of transmitter at different input IF power	111
Table 5.9	Low noise amplifier gain at different frequencies	112
Table 5.10	IF output power at different LO and RF input power	114
Table 5.11	IF signal power at different input power levels of RF signal	120
Table 5.12	IF output power at different value of attenuator	122

List of Abbreviations

ADC	Analog to Digital Converter
ADS	Advanced Design System
ASK	Amplitude Shift Keying
BPF	Bandpass Filter
CCD	Charge Couple Device
CDMA	Code Division Multiple Access
CMOS	Complementary Metal Oxide
CST	Computer Simulation Technology
DAC	Digital to Analog Converter
dB	Decibel
DC	Direct Current
DECT	Digital European Cordless Telephony
FR4	Flame Retardant
GaAs	Gallium Arsenide
GPS	Global positioning System
HBT	Heterojunction Bipolar Transistor
I	Inphase
IF	Intermediate Frequency
ISM	Industrial Scientific & Medical
LNA	Low Noise Amplifier
LO	Local Oscillator
LTE	Long Term Evolution
MCU	Microcontroller Unit
PLL	Phase Locked Loop
Q	Quadrature
RF	Radio Frequency
RSSI	Received Signal Strength Indication
VCO	Voltage Control Oscillator
WIMAX	Worldwide Interoperability for Microwave Access
WLAN	Wireless Local Area Network
WPAN	Wireless Personal Area Network

REKABENTUK BAHAGIAN HADAPAN PEMANCARTERIMA TANPA WAYAR JALUR LEBAR

ABSTRAK

Dalam tesis ini, sebuah pemancarterima tanpa wayar yang beroperasi pada frekuensi 5.8 GHz untuk aplikasi penghantaran imej telah direkabentuk untuk mencapai lebar jalur 200 MHz dengan angka hingar sebanyak 2.5 dB. Prototaip pemancarterima telah dibina menggunakan komponen sedia siap daripada Mini-circuit dan Hittite kecuali penapis 132 MHz dan 5.8 GHz. Ia terdiri daripada penerima superheterodin dan pemancar superheterodin bersama dengan pengayun tempatan dan penguat kuasa IF. Seni bina superheterodin telah digunakan dalam mereka bentuk pemancarterima ini kerana ia tidak rumit dan sesuai untuk ADC yang beroperasi pada resolusi yang tinggi lebih daripada 320 MHz. Terdapat dua jenis penapis lulus jalur telah direka bentuk dalam projek ini iaitu elemen tergumpal untuk frekuensi rendah dan teragih untuk aplikasi frekuensi yang tinggi. Spesifikasi untuk penapis lulus jalur jenis elemen tergumpal ialah 132 MHz dengan lebar jalur 200 MHz. Satu lagi penapis lulus jalur ialah struktur baru penapis lulus jalur 5.8 GHz telah dibangunkan dengan menggunakan gabungan penyalun pecahan bulatan dan garisan penghantaran penyatuan hujung diperkenalkan dalam kajian ini. Struktur padat penyatuan rapat daripada dua garisan penghantaran penyatuan hujung merangkumi dua penyalun pecahan bulatan suku panjang gelombang boleh memperbaiki kehilangan sisipan yang tinggi dalam jalur lulus peranti tersebut. Penghantaran penyatuan hujung digunakan untuk memperbaiki kehilangan balikan yang tinggi. Kelebihan pendekatan struktur baru ini ialah pengurangan saiz dengan penyingkiran tinggi di peralihan jalur curam untuk kedua-dua pintasan frekuensi bawah dan atas. Ukuran penyalun pecahan bulatan boleh dilaraskan untuk dapatkan jalur sempit atau lebar. Reka bentuk ini menghasilkan jalur lebar dari 203 MHz pada frekuensi 5.86 GHz dengan

kehilangan sisipan yang terbaik dalam lulus jalur daripada pengukuran iaitu 2.64 dB. Rekabentuk dan simulasi pemancar penerima dilakukan menggunakan Advanced Designed System (ADS). Manakala, Computer Simulation Technology (CST) digunakan untuk merekabentuk penapis lulus jalur yang beroperasi pada frekuensi 5.8 GHz dengan lebar jalur 200 MHz. Pengesahan untuk rekabentuk ini dilaksanakan melalui ujian perkakasan pemancar dan penerima. Pemancar telah menaikkan isyarat IF pada frekuensi 132 MHz ke isyarat RF pada frekuensi 5.8 GHz, manakala penerima menurunkan isyarat RF dari frekuensi 5.8 GHz ke isyarat IF kembali pada frekuensi 132 MHz. Pemancar mempunyai masukan isyarat IF -20 dBm pada frekuensi 132 MHz dan -39.83 dBm kuasa keluaran signal RF pada frekuensi 5.8 GHz. Sementara penerima mempunyai isyarat RF sebanyak -50 dBm pada frekuensi 5.8 GHz dan -35.33 dBm kuasa keluaran pada frekuensi 132 MHz. Ujian pemancar penerima pula mempunyai -20 dBm isyarat IF kuasa masukan pada 132 MHz dan -24.83 dBm pada 132 MHz.

DESIGN OF WIDEBAND RF FRONT END WIRELESS TRANSCEIVER

ABSTRACT

In this thesis, a wireless transceiver operating at 5.8 GHz for image transmission application is designed and fabricated. It provides wide bandwidth of 200 MHz with noise figure of 2.5 dB. The transceiver's prototype was built using off-the-shelf components from Mini-Circuit and Hittite except 132 MHz and 5.8 GHz bandpass filter. It consists of a superheterodyne receiver and a superheterodyne transmitter analog front-end together with local oscillator and IF amplifier. Superheterodyne architecture was implemented in this transceiver design because it is not complicated design and suitable for high resolution ADCs operating over 320MHz. There are two types of bandpass filter was designed in this project which are lumped element for low frequency and distributed for high frequency application. The specification for the lumped element bandpass filter is 132 MHz with 200 MHz bandwidth. Another bandpass filter is a novel structure of 5.8 GHz bandpass filter has been developed using a combination of split-ring resonator (SRR) and end-coupled transmission lines was introduced in this research. The compact structure from a close couple of two end-coupled transmission lines embedded by two quarter wavelength of split-ring resonators were able to improve the high insertion loss in the passband of the device. The end-coupled transmission line was found to be a parameter that can improves the performance of return loss. The advantage of this new structure approach is a size reduction with a high rejection as well as steep transition bands for both lower and upper cutoff frequencies. The dimensions of the split-ring can be tuned to obtain a narrow or wide band. This design produces a bandwidth of 203 MHz at 5.86 GHz with the best insertion loss in passband from the measurement was 2.64 dB. The overall design and simulation of the transceiver are performed using Advanced

Designed System (ADS). Whereas, Computer Simulation Technology (CST) are used to design the 5.8 GHz bandpass filter. Verification of the design is accomplished through transmitter and receiver hardware testing. The transmitter upconverted IF input at 132 MHz to an RF of 5.8 GHz, while receiver downconverted an RF input at 5.8 GHz to an IF of 132 MHz back. The transmitter has IF input signal level of -20 dBm at 132 MHz and -39.83 dBm RF output power at 5.8 GHz. While receiver has RF input signal level of -50 dBm at 5.8 GHz and -35.33 dBm output power at 132 MHz. For the transceiver testing, it has -20 dBm IF input power at 132 MHz and -24.83 dBm output power at 132 MHz.

CHAPTER ONE

INTRODUCTION

1.1 Background

In wireless communications, the channel medium is typically based on radio frequency which has limited frequency spectrum resources. The limited bandwidth is crowded which show the amount of multimedia contents sent represented by data packets. To the extent that the image is concerned due to the correlation among adjacent pixels, compression of image can be achieved for efficient storage and transmission (Hoang Dung et al., 2004). The process of these image transmission systems involve the installation of image sensor or camera, transmitting image to monitor centre which analyzes , processes and saves the image data, then distributes the useful image to the terminal unit such as mobile phone or computer (Xiangyuan et al., 2008). Image could be transmitted through GPRS/CDMA or WLAN wireless network through front end transceiver(Hoang Dung et al., 2004).

In this research, this transceiver was demonstrated by an integrated prototype, which is compatible to the IEEE 802.11a standard. Because off-the-shelf components and commercially available wireless radios do not fulfill the stringent requirements of our approach by designing transceiver operating at 5.8 GHz with 200 MHz due to bandwidth requirement for image transmission. Moreover, many of them cannot be configured to feature this concept, the transmitter and the receiver are designed part by part, leads to easy for modification and troubleshooting work.

This transceiver was designed based on the Federal Communications Commission (FCC) standard. It has allocated 700 MHz of bandwidth in the 5.15 – 5.85 GHz range. Flexible design was possible due to the availability of about 700 MHz of bandwidth in this 5 GHz spectrum band. By designing the system in the 5.8 GHz band with 200 MHz bandwidth can minimize the interference from the existing systems as there are very few systems operating in this spectrum. Besides that, the availability of cheap and reliable commercial components in the 5 GHz band, indirectly increased the interest in the design and deployment of commercial wireless systems like wireless data communications and point to point communications.

The main tasks in this design process comprise the specification of the subsystems in the transmitter and the receiver including their design and optimisation. This thesis describes the specification and the architecture of the analogue transceiver front-end together with the final assembling of all sub-system of this transceiver. The description of the components and subsystems are accompanied by verifications based on simulations and measurements.

There are different components in the RF front-end section. On the receiving path, starting from the antenna, the major components include LNA, BPF down-conversion mixer and local oscillator. The down-converted signal is then passed to the demodulator for further low frequency or baseband signal processing.

On the transmitting path, the signal from the modulator is passed to an up-conversion mixer. The up-converted signal is passed through a band pass filter and

then amplified by a PA. The amplified signal is ready for transmission through the antenna.

Figure 1.1 depicts the architecture of the RF front-end transceiver, which is capable of performing the intended operations for the 802.11a standard.

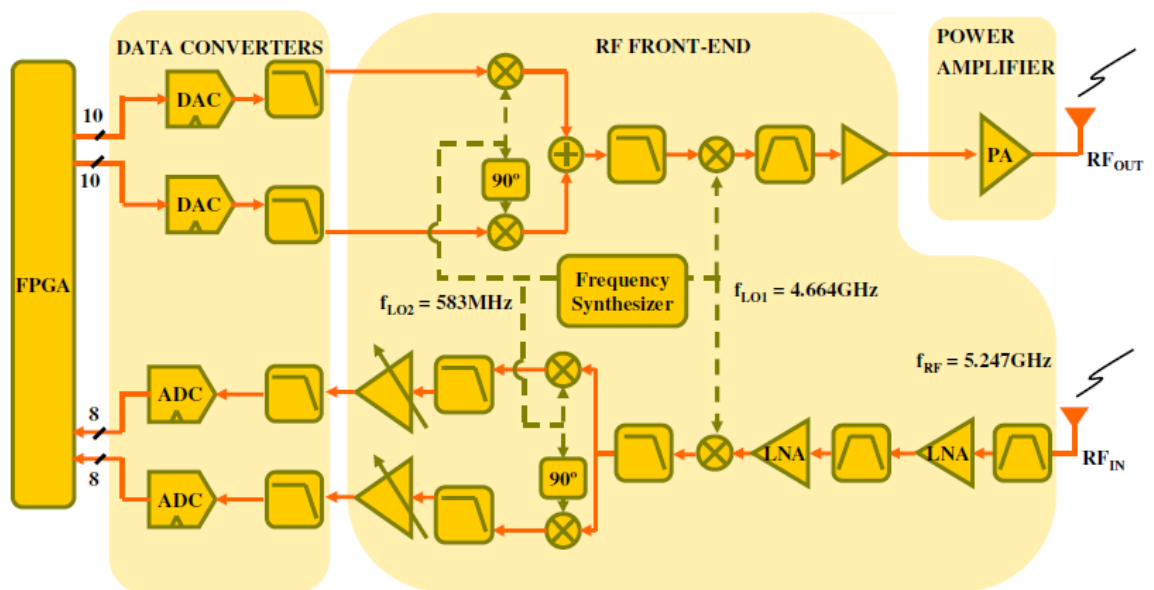

Figure 1.1: Architecture of the RF front-end transceiver (Matalon, 2005)

1.2 Motivation

The current Bluetooth technology is considered a wireless Personal Area Network (WPAN) system, wished-for cable replacement and short distance ad hoc connectivity. It's operate at 2.4 GHz Industry Scientific and Medical (Zongyang et al.) unlicensed band and normally it confined to a person or object and extend up to 10 meters in all direction. This is in contrast to Wireless Local Area Networks (WLANs) which is cover a moderate sized geographic area and operate in the 100 meter range (Golmie et al., 2003). The WLAN standard that will emphasize here is

802.11a operate at 5 GHz band has a significant advantage, since the 2.4 GHz band is heavily used and being crowded.

In general, the RF front-end part is the most power hungry portion of a transceiver. If we can reduce the power consumption of the front-end part, it will be a significant achievement to minimize the power consumption of the transceiver. As a result, the overall power consumption of the wireless device can also be reduced (Golmie et al., 2003).

The power consumption in such devices has to be low to ensure a longer battery life. The number of wireless users is increasing exponentially, and the limited frequency spectrum must be used in an efficient way. One of the techniques that have been used to service multiple channels in a limited frequency bandwidth is to place the channels closer to each other (Abed et al., 2005).

It is necessary to design and develop the wireless transceiver by maintaining each of wireless transceiver system sufficiently with a minimum power. At the same time, the overall system interference is kept to a minimum and, in the case of mobile stations, battery life is maximized.

1.3 Problem Statement

Since the advent of the computer there has always been a requirement to send data. Data inside the system has traditionally been passed in a parallel or serial form. Once data is transmitted out of the system, cable sizes required to carry the data and crosstalk issues associated with multiple signals in close proximity make serial or parallel data transfer problematic. In order to avoid the problem, wireless communication is the best option. Moreover, it is easier to provide connectivity in areas where it is difficult to lay cable. Long-term cost benefits can be found in dynamic environments requiring frequent moves and changes by using wireless communication, and also the network can be access anywhere within the range of an access point.

There are some advantages to move into higher frequencies. The 2.4 GHz has been used for decades for short-range communications. Nowadays, the 2.4 GHz bands are widely used for consumer devices, such as baby monitors, cordless phones, microwave ovens, Bluetooth interdevice communications and wireless LAN for the 2.4 GHz band. But, the 5.8 GHz band is less crowded. The higher the traffic is in the band, the more complex the transmitter and receiver have to be in order to pierce through the interference and maintain signal quality. As a result it will increase the complexity and price of the device. It is therefore more interesting to use a non-crowded band, for instance the 5.8 GHz, to better handle large-capacity tracking systems. Besides that, at 5.8 GHz, bit error rate (BER) is much better because of a less crowded bandwidth.

Most short-range communications occur around human-made constructions, such as vehicles and buildings. For mid-range communications of distances within 1 km and for the same transmitted power level, 5.8 GHz offers almost the same communication range than 2.4 GHz. The 5.8 GHz band offers the smallest Fresnel diffraction zone compared to 2.4 GHz. Due to its shorter wavelength, 5.8 GHz can pass through very narrow spaces. At the same time, it maintains similar penetration capabilities through materials as the 2.4 GHz band. Therefore, the 2.4 GHz is blocked or diffracted by obstacles because of its longer signal wavelength of 12.5 cm, 5.8 GHz can easily pass through unhindered due to its very short 5.17 cm wavelength. Signal wavelength impacting device size and performance

1.4 Objectives

The objectives of this research is:

1. To design, fabricate and characterize a 5.8 GHz RF front end wireless transceiver for image transmission.

1.5 Thesis outline

This thesis is divided into five chapters. It is organized in such way as to properly layout the detail investigations and results of the research work. The background, problem statement, motivation and objective are presented in Chapter 1 with a summary of the thesis outline.

Chapter 2 is an overview on wireless transceiver and general background on parts of transceiver which are power amplifier, low noise amplifier, upconverter, downconverter, bandpass filter, multiplier and local oscillator.

Chapter 3 presents the design of the wireless transceiver. Hardware design and development is discussed in detail. It also presents the flowchart of methodology of transceiver design.

Chapter 4 presents performance of simulation and measurement result. It concludes the overview of test bed and its subsystem. Discussion analysis is done for both theoretical and experimental.

Chapter 5 highlights the overall conclusion of the thesis. It also provides the recommendation for future study.

CHAPTER TWO

LITERATURE REVIEW

2.1 Introduction

As communications among mobile communications, broadcast, and local networks convergence, there is need for a device to support a wide range of frequencies. In addition, the demand for complex devices has been increase as various standards such as m-WiMAX, LTE and etc. emerge. In addition, the structure of a multi-band or multi-mode RF transceiver is shifted from a multi-chain architecture to a reconfigurable architecture. This shift is caused by the growth of wireless communications to include a common vision of the fourth generation of mobile communications, higher data rates, higher mobility and ubiquitous information access. To cope with this change in the communication environment, development of multi-band RF technology is necessary (Chun et al., 2011) with wide range of services including voice, data and multimedia service (Ni et al., 2000).

The main challenge to design wideband, or in a restrictive term UWB, transceivers is to satisfy gain, NF, reverse isolation, and linearity requirements over a wide bandwidth. Recently, different circuit techniques have been proposed to achieve wideband operation for the RF front-end. One of the solution to the UWB design is to extend conventional narrowband techniques to wideband by using higherorder bandpass filters to achieve required wideband input matching (Safarian et al., 2006).

2.2 RF front end wireless transceiver

Most of the transceivers operate at 5 GHz band which is can provide very high throughput multimedia services to terminals at a transmission speed of 200 Mbps in a region that is within a 100m radius (Lee et al., 2010). Table 2.1 compares the several transceiver performance in term of frequency, bandwidth, noise figure and transmitter output.

Table 2.1: Performance comparison of RF front end wireless transceivers

References	Frequency (GHz)	Bandwidth (MHz)	NF at receiver (dB)	Transmitter Output power (dBm)
(Ni et al., 2000)	1.89	3.072	1.2	30
(Young, 1997)	1.885- 2.025	5	5	16.33
(Lee et al., 2010)	5.25	120	-	15
(Chun et al., 2011)	5.0	16.55	5.5	-

In (Ni et al., 2000), the transceiver operate at 1.89 GHz and the bandwidth is 3.072 MHz. It's noise figure is 1.2 dB and the output power level at the antenna is +30 dBm. The incoming RF signal at the receiver is first band limited to eliminate the

undesired noise and then amplified 27 dB by the LNA. The frequency of the local oscillator is 1890 MHz and the IF output of the downconverter is 70 MHz.

The transceiver developed by (Young, 1997) operate at 1.885 GHz to 2.025 GHz. The transmitter is a double up conversion configuration. The 21.4 MHz IF signal is first mixed up to 140 MHz, then to 1965 MHz to 2025 MHz UHF. Whereas, the receiver also is a double down conversion configuration using low side injection. The 1885 MHz to 1945 MHz UHF is first mixed down to 140 MHz, then to 21.4 MHz. For this transceiver the bandwidth is 5 MHz with a NF of 5 dB and the transmitter output power is 16.33 dBm.

The third transceiver was taken for comparison was invented by (Lee et al., 2010), the implementation of this RF transceiver based on the wide-band MIMO-concept operating at 5.25 GHz in a 120 MHz bandwidth. The baseband I and Q signals underwent quadrature modulation at a low IF, 80 MHz, and the result was up-converted to 5.25 GHz by mixing with frequency of 5.17 GHz generated by local oscillator. Then the RF power amplifier amplify the RF frequency to a maximum power of 15 dBm before transmit to the air through antenna.

The last comparison for the transceiver was developed by (Chun et al., 2011), it 's operate at 5.0 GHz with 16.55 MHz bandwidth. The NF for this transceiver is 5.5 dB.

2.3 Bandpass filter

Filters are essential in microwave communication system. It is used to control the frequency response at a certain point in a microwave system by providing transmission at frequencies within the passband and attenuation in the stopband of the filter (Pozar, 1990). It is also necessary for suppressing spurious components generated by multipliers (Ikematsu et al., 2002). The microstrip will be used in order to design the bandpass filter due to have many attractive features such as lower loss and reduced parasitic(Kraus et al., 2004). The types of filter separated according to frequency as listed below:

Table 2.2: Types of filter

	Types	Frequency Range
Passive	Discrete inductors and capacitors	0 GHz - 1 GHz
	Crystal Lattice	0 GHz - 250 MHz
	Surface acoustic wave	0 GHz - 1 GHz
Hybrid	Helical	2 GHz – 3 GHz
Distributed	Transmission Line	1 GHz – 100 GHz
	Dielectric Resonators	1 GHz – 100 GHz
	Waveguide	100 MHz - near light
Active	Operation Amplifier	0 GHz – 50 MHz
Digital	FIR & IIR Upper Frequency	0 GHz – 100 MHz

2.3.1 End-coupled structure

End-coupled microstrip filters are the most commonly used topologies in microwave planar filters and some work has been reported on their realization in CPW. The end-coupled topology was first investigated because it is more compact, but it was soon found that the input and output couplings could not be made tight enough with end-coupled lines. In term of the size of this type of structure, it could be miniaturized by using multilayer techniques and at the same time it can reduce the cost for filter within a MMIC packaging environment (Karacaoglu et al., 1995).

The end-coupled structure also to able control the spurious response with a compact filter size (Hee-Seok and Young-Shin, 2003) which is represent transmission lines 1 and 2. This structure is very suitable in designing a narrowband filter (Bin and Uysal, 1998) because it has an electrical coupling due to fringing fields exist at both open ends of the resonators and hence the inter-resonator electric coupling coefficient is found to be a function of inter-resonator capacitance (Sekar, 2008). Besides that, a large value of capacitance can be obtained from the end-coupled structure (Bin and Uysal, 1998).

The general configuration of end-coupled stripline BPF with half wavelength resonator of center frequency is shown in Figure 2.15(a). The band gap can be modeled as a π -type capacitance as shown in Figure 2.15(b). Whereas the electrical representation and the structure contains J-inverters shown in Figure 2.15(c) (Min-Soo et al., 2004).

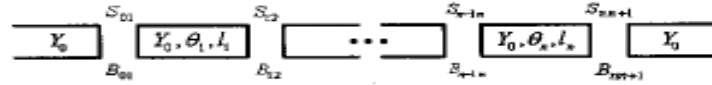

(a) General configuration

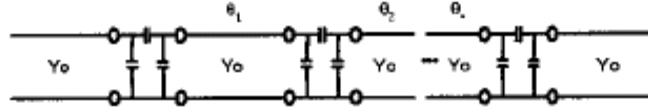

(b) Equivalent model of BPF

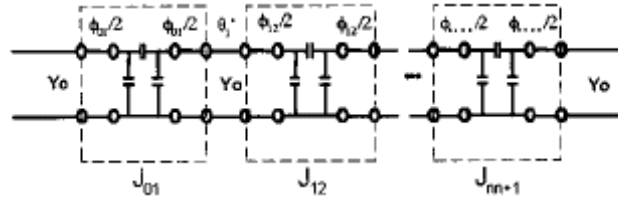

(c) Equivalent model with J-inverter

Figure 2.1: The configuration of end-coupled line BPF (Min-Soo et al., 2004)

The value of J-inverter can be obtained by using the equation in (Pozar, 2000) below and the type, order and ripple (in chebyscheff type) of the filter already determined. Whereas the g_0, g_1, \dots, g_n are the element of a ladder type low pass prototype with a normalized cutoff frequency and the fractional bandwidth (FBW) of the BPF as

$$\text{defined } \frac{F_{high} - F_{low}}{F_{center}} \text{ (Min-Soo et al., 2004).}$$

2.3.2 Split-ring resonator structure

The dual-mode ring filter introduced starting in (Wolff, 1972), it had encouraged much effort on various innovative designs (Yu-Zhen et al., 2008) because the ring is free of open-ended (Woo-Chul et al., 1999). Recently, ring resonator widely used in the

design of filters because it has several advantages of compact size, high-Q and commonly used in narrow-band applications, having typically less than 5% bandwidth (Woo-Chul et al., 1999, Chul-Soo et al., 2005). Whereas end-coupled structure also used in designing of this new bandpass filter due to its compact size, lightweight, low cost and ease of fabrication (Mandal et al., 2008). However, they have a problem due to their typical high insertion loss especially to achieve narrow bandwidth (Chul-Soo et al., 2005, Bin and Uysal, 1998).

Besides that, the SRR can be considered as an electronically small resonator with a very high Q, the structure is very practical in order to construct filters which are requiring a sharp stop or pass of a certain frequency band (Zhiyuan and Qi, 2007). Many other resonator topologies invented from the basic SRR structure proposed by (Jaewon and Chulhun, 2008).

These structures are sub-wavelength resonators and able to obstruct signal propagation in a narrow band closed to their resonant frequency, provided the magnetic field is polarized along the axis of the ring. The induced current loops are closed through the distributed capacitance between concentric rings at resonance can clarify the frequency-selective behavior. Whereby the SRRs able to inhibit signal propagation due to it attribute as LC resonant tanks that can be externally driven by magnetic field (Jaewon and Chulhun, 2007).

CHAPTER THREE

THEORETICAL STUDY

3.1 Introduction

Nowadays, multimedia communications of text voice audio image and video transmission through wireless links have been popular. After text and voice, image transmission is the next achievable and attractive area for the realization of transmission of multimedia contents in current mobile computing era. It also establishes the basis for video transmission in wireless links (Hoang Dung et al., 2004).

In general, remote image transmission system is made up image collection subsystem, image compression subsystem and image transmission subsystem. Image could be transmitted through GPRS/CDMA or WLAN wireless network and the standards of image compression are Joint Photographic Experts Group (JPEG), Bitmap (BMP), Portable Network Graphics (PNG) and Tagged Image File Format (TIFF). The objective of image compression is to reduce redundancy of the image data in order to be able to save storage costs or transmission time (Xiangyuan et al., 2008). Figure 3.1 shows the basic block diagram of wireless network for image transmission.

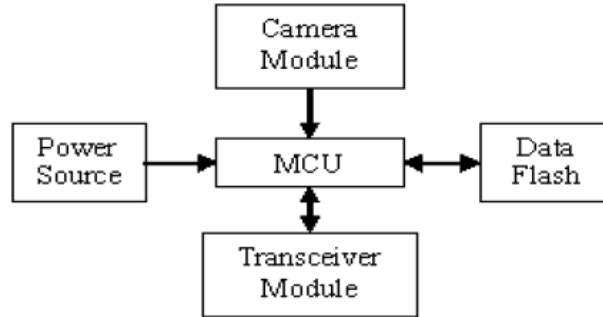

Figure 3.1: Block diagram of wireless network for image transmission

3.1.1 Visual sensor

In cameras and vision systems, the image sensor plays an important role in system performance. Image quality in term of sensitivity and dynamic range and also resolution (pixel number) are significant parameters which characterize the image sensor. There are two types of image sensors are frequently used in many applications. They are CCD and CMOS (Hamid et al., 2009).

CCD sensors implement readout techniques based on displacement maps: the electron charge accumulated by each photodiode from one row (pixel) is displaced to the next in the same column until the last photodiode in the same, which is connected to an analog converter and data acquisition system. Control electronics system permit synchronized acquisition of values for the entire sensor matrix (Bravo et al., 2011).

While CMOS sensors use the latter technology to implement a photosensitive matrix. It is based on digital memory readout techniques by using row decoders which permit random access and the selection of regions or windows of interest. Each pixel contains the electronic circuitry necessary to convert the electrical charge into tension,

and this affects the fill factor which relates the data acquisition area to the pixel matrix conversion area. These sensors attain very low readout times. In order to characterize the image acquisition task, pixel number per second is used rather than the image number per second used by CCD sensors (Bravo et al., 2011).

3.1.2 Microcontroller

Nowadays with the advance development of microcontroller system, the processing of image can be implemented by the microcontroller. There are several types of microcontrollers or microprocessors which used in image processing. They are Digital Signal Processors (DSPs), Field Programmable Gate Arrays (FPGAs) and multimedia processors. The selection of which to use will depend on the application, and basic considerations include flexibility, processing performance, low Non-Recursive Engineering (NRE) cost, low energy consumption and level of programmability (Bravo et al., 2011).

3.1.3 Front End Transceiver

The RF module comprises of an RF Transmitter and an RF Receiver and it operates at Radio Frequency. The corresponding frequency range varies between 30 kHz & 300 GHz. At the transmitter parts, it will broadcast the processed messages from the microcontroller. While at the receiver parts, it will receives the message and transfer it to the microcontroller to be further displayed on the screen or LCD. At the same time, rebroadcast the received signal to ensure long distance communications.

3.2 Microstrip Transmission Line

Microstrip transmission lines are widely used planar transmission line in Radio frequency (RF) applications. The planar configuration can be achieved by several ways, for example with the photolithography process or thin-film and thick film technology. In the other words (Alaydrus, 2010), the microstrip line is a transmission-line geometry with a single conductor trace on one side of a dielectric substrate and a single ground plane on the opposite side. The microstrip line has a major fabrication advantage over stripline because it is an open structure. It also features ease of interconnections and adjustments (Maloratsky, 2000). Like other transmission line in RF applications, microstrip can also be used for designing certain components, such as filter, coupler, transformer or power divider. Figure 3.2 shows a microstrip transmission line which is used for transport of wave with relative low frequency, the wave type propagating in this transmission line is a quasi-TEM wave. This is the fundamental mode in the microstrip transmission line (Alaydrus, 2010).

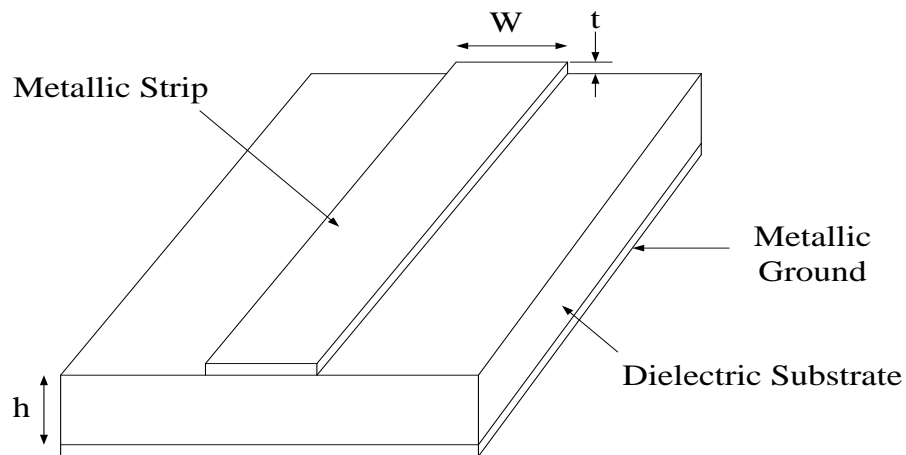

Figure 3.2: Microstrip transmission line

The width of the strip W together with the dielectric constant and the thickness of the substrate determines the characteristic impedance Z_o of the line (Alaydrus, 2010). In order to design the RF circuits, the impedance matching is important for tuning load impedance to the optimum impedance of a connected device. In the other words, matching network plays a vital role in any electronic circuit without which the system response suffers badly. Figure 3.3 shows the block diagram of a matching network which is placed between a load impedance and a transmission line. The presence of the matching network is ideally lossless to avoid the unnecessary loss of power, and is usually designed so that the impedance seen looking into matching network is Z_o (Tiwari, 2010).

Then the reflections are eliminated on the transmission line to the left of the matching network, even though there will be multiple reflections between the matching network and the load. This procedure is also referred to as tuning. Impedance matching or tuning is important for the following reasons (Tiwari, 2010):-

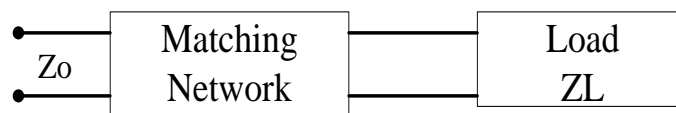

Figure 3.3: Block diagram of a matching network

(a) Maximum power is delivered when the load is matched to the line (assuming that generator is matched) and power loss in the feed line is minimized. (b) Impedance Matching sensitive receiver components such as antenna, LNA etc. could improve the

signal to noise ratio of the system. (c) Impedance matching in a power distribution network such as antenna array feed network will reduce amplitude and phase errors (Tiwari, 2010).

3.3 Transceiver

Driven by increasing demand in term of bandwidth, data-rate, size and cost in wireless communication (Tatu et al., 2008), the communication equipment manufacturers had encouraged to develop product using the 5.8 GHz (Luff et al., 2004). It is quite challenging to design a high operating frequency of analog front-end wireless communication. There are three critical aspects need to be consider in order to design front-end wireless communication. They are wide bandwidth, large dynamic range and (especially for multicarrier system) a good linearity (Wambacq et al., 1999). However, transceiver architectures that are amenable to high-level of integration and support the large transmission bandwidths and high carrier frequencies needed for higher data throughput will inevitably suffer from RF impairment, which limit their performance and hence hindering their wide-spread use in commercial products. The RF impairments of the transceiver can be divided into two categories: phase and gain mismatches in the In-phase (I) and Quadrature (Q) paths of the quadrature up-converter at the transmitter and the quadrature down-converter at the receiver, carrier phase and frequency synchronization errors, phase noise and power amplifier non-nonlinearties (Cetin et al., 2007).

Generally, the transceiver can be divided into two parts: the RF/analog front-end part and the digital back-end part. The front-end part is responsible for the transmission and reception of analog signals, and the back-end part is in charge of the base-band process and handover control (Zongyang et al., 2007). The physical layer implementation of almost any modern wireless device consists of three main parts as shown in Figure 3.4: the antenna, the analog part of the transceiver and the digital part of the transceiver.

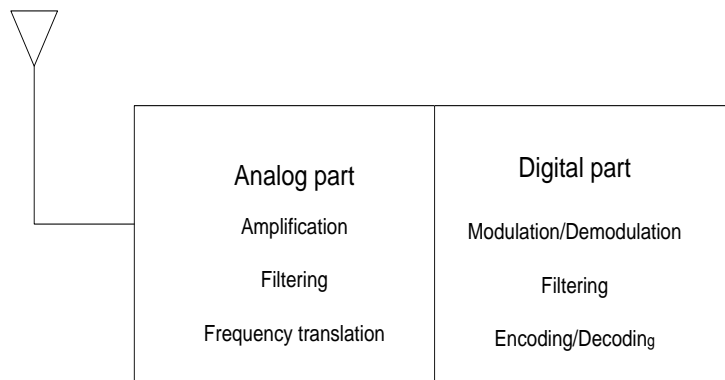

Figure 3.4: General block diagram of transceiver

3.4 Transmitter

Generally, the signal processing in wireless communication takes place in the digital domain with signal frequencies significantly lower than the radio frequency (RF) that is needed for transmission. Therefore, to perform the transmission, an upconversion of the baseband signal is needed. This upconversion can be accomplished in various manners including analogue mixing, direct digital conversion and combined digital/analogue upconversion (Sommarek, 2007).

The designs of RF transmitters for wireless applications lead to many challenges at both architecture and circuit levels. The number of off-chip components, the restrictions on unwanted emissions and the trade-offs between the output power, the efficiency and the required linearity directly impact the choice of the transmitter topology and the implementation of each circuit block (Razavi, 1999).

The selection of transmitter architecture depends on two major factors: wanted and unwanted emission requirements and the number of oscillators and external filters. Generally, the architecture and frequency planning of the transmitter must be selected in conjunction with those of the receiver so as to allow sharing hardware and possibly power (Razavi, 1999).

In order to design the transmitter, it required a solid understanding of modulation schemes because of their influence on the choice of such buildings blocks as upconversion mixers, oscillators and power amplifiers (Razavi, 1999). In the other words, the transmitter performs modulation, upconversion, and power amplification (Zou, 2000). It can be divided into two main groups (Oliveira et al., 2008):

- a) Heterodyne – that use an intermediate frequency;
- b) Direct upconversion – that converts directly the signal to the RF band.

3.4.1 Heterodyne Transmitters

Figure 3.5 shows the heterodyne architecture which is the most often used architecture in transmitters. In heterodyne transmitters the baseband signals are modulated in quadrature with carrier frequency (modern transmitters must handle quadrature signals) to the lower frequency ω_1 [called the intermediate frequency (IF)], since it is easier to provide accurate quadrature outputs at IF than at RF. The IF filter that follows rejects the harmonics of the IF signal, and reduces the transmitted noise (Oliveira et al., 2008).

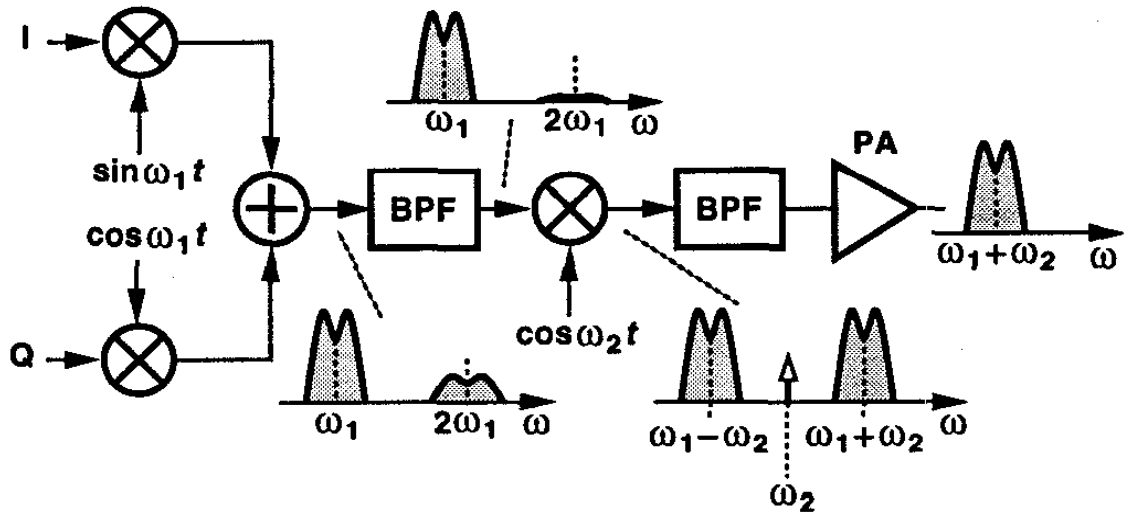

Figure 3.5: Heterodyne transmitter (Razavi, 1999)

Then the IF modulated signal is upconverted to $\omega_1 + \omega_2$ by mixing and then amplified by the power amplifier before transmitted by the antenna. The first BPF suppresses the harmonics of the IF signal while the second removes the unwanted sideband centered around $\omega_1 - \omega_2$ (Razavi, 1999). In the other words, the RF band-pass filter used to suppress around 50 dB to 60 dB the unwanted sideband after the upconversion, in order to meet spurious emission levels imposed by the standards. This

filter is typically passive and built with inexpensive off-chip components. This topology does not allow full integration of the transmitter, due to the off-chip passive components in IF and RF filters (Oliveira et al., 2008).

An advantage of heterodyne over the direct conversion approach is that since quadrature modulation is performed at lower frequencies, I and Q matching is superior, leading to less cross-talk between two bit streams. Also, the channel filter could be used at the first IF to limit the transmitted noise and spurs in adjacent channels (Razavi, 1999).

3.4.2 Direct Upconversion Transmitters

In this type of transmitter, shown in Figure 3.6, the baseband signal is directly upconverted to RF. The RF carrier frequency is equal to the LO frequency, at the mixers input. A quadrature upconversion is required by modern modulations schemes. This topology can be easily integrated, because there is no need to suppress any mirror signal generated during the upconversion. As in the receiver, the local oscillator frequency is the carrier frequency (Oliveira et al., 2008).

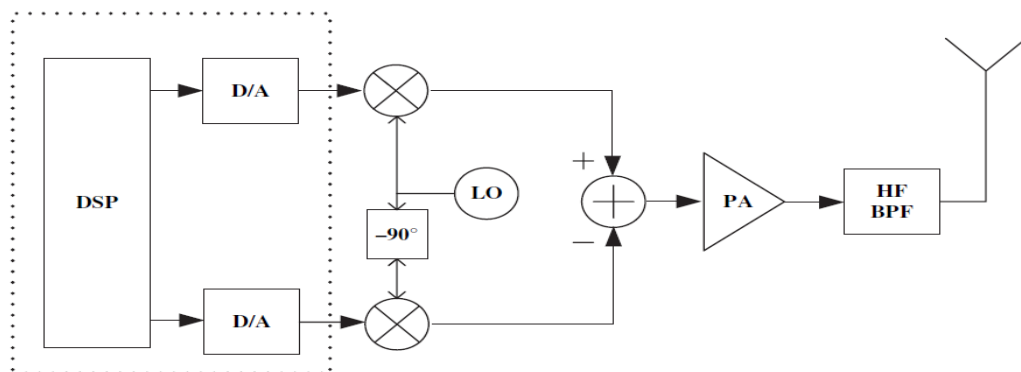

Figure 3.6: Direct upconversion transmitter (Oliveira et al., 2008)

The architecture as shown in Figure 3.6 is called direct-conversion because the carrier frequency is equal to the local oscillator frequency. There are several disadvantages of this simple architecture (Oliveira et al., 2008). First, the quadrature upconverter cannot suppress the LO signal completely at its output. Often referred to as ‘LO leakage’, this residue LO appears at the transmitted spectrum and acts as interference to other receivers. Secondly, since the shielding from the power amplifier to the local oscillator is finite, the strong signal of the power amplifier will corrupt the local oscillator spectrum. To avoid this phenomenon (referred to as “injection pulling” or “injection locking” of the local oscillator by the high level PA output), a two-step transmitter architecture is proposed. As shown in Figure 3.6, the baseband signal is upconverted twice such that the power amplifier output spectrum is far from the frequencies of the local oscillator. The first BPF suppresses the harmonics of the IF signal and the second BPF removes the unwanted sideband due to the simple upconversion (Zou, 2000).

3.5 Receiver

The receiver RF topology, defined here as RF analog section, detects the wanted signal at high frequencies and down-convert it to a low IF or zero IF. As the wireless receiver need to be highly integrated, the RF section has to be simple and robust. There are four types of receiver structure which are superheterodyne, direct conversion, wide-band IF and low IF receiver (Yoo, 2004).