

This is a repository copy of *Design of the Synthetic Aperture Microwave Imager Upgrade for measurement of the edge current density on MAST-U*.

White Rose Research Online URL for this paper:
<https://eprints.whiterose.ac.uk/144128/>

Version: Published Version

Article:

Allen, Joe Oliver, Vincent, Charles and Vann, Roderick G L orcid.org/0000-0002-3105-2546 (2019) Design of the Synthetic Aperture Microwave Imager Upgrade for measurement of the edge current density on MAST-U. EPJ Web of Conferences. 03004. ISSN 2100-014X

<https://doi.org/10.1051/epjconf/201920303004>

Reuse

This article is distributed under the terms of the Creative Commons Attribution (CC BY) licence. This licence allows you to distribute, remix, tweak, and build upon the work, even commercially, as long as you credit the authors for the original work. More information and the full terms of the licence here:

<https://creativecommons.org/licenses/>

Takedown

If you consider content in White Rose Research Online to be in breach of UK law, please notify us by emailing eprints@whiterose.ac.uk including the URL of the record and the reason for the withdrawal request.

Design of the Synthetic Aperture Microwave Imager Upgrade for measurement of the edge current density on MAST-U

J.O. Allen^{1,*} and C. H. Vincent²·R. G. L. Vann¹·

¹York Plasma Institute, Department of Physics University of York, York, YO10 5DD, UK

²Centre for Advanced Instrumentation, Department of Physics Durham, DH1 3LE, UK

Abstract. The Synthetic Aperture Microwave Imager (SAMI) has demonstrated the feasibility of 2D Doppler backscattering for measurement of the edge magnetic pitch angle on MAST and NSTX-U. The aim of SAMI-Upgrade (SAMI-U) is to build on this methodology to produce higher quality pitch angle data simultaneously in multiple spatial locations, enabling calculation of the edge current density. This movement from proof of principle to production quality necessitates several alterations to the design. There will be a fourfold increase in the number of antennas, as minimising the sidelobe level is key to ensuring maximum resolution in the reconstructed Doppler backscattered power map. SAMI-U will actively probe the plasma with two frequencies at the same time. These correspond to two different backscattering locations in the edge plasma which allows the edge current density to be calculated from the measured magnetic field vector. Dual-polarised sinuous antennas will be used in the array as they are planar and broadband. Polarisation separation is necessary for differentiation between the O- and X-mode cut off surfaces, as their locations can be separated by up to a few centimetres. Due to spatial constraints many of the components will be placed on a PCB behind each antenna. FPGAs will be used to stream the high data throughput, over 16 GB s^{-1} , into PC memory.

1 Introduction

For future tokamaks, such as ITER, the energy released by the largest edge-localised mode (ELM) instabilities will critically damage components [1, 2], therefore understanding the ELM mechanism in order to suppress or mitigate their effects is important for future devices. Several diagnostic methods have been employed so far to measure the edge current density. These include the Zeeman effect [3, 4], the motional Stark effect (MSE) [5] and beam emission polarimetry [6]. However, these are all indirect methods which do not necessarily work at all times throughout a plasma shot. Consequently a diagnostic to deliver direct and continuous edge current density measurements is desirable. By making high quality direct measurements of the edge magnetic pitch angle at multiple radial locations, SAMI-U will produce a profile of the edge current density throughout the plasma lifetime on MAST-U.

2 Summary of SAMI results

SAMI was used to make passive measurements, of plasma thermal emission, as well as active measurements, when probing the plasma with a broad microwave beam, of the plasma edge. It was installed on MAST to passively investigate electron Bernstein wave (EBW) mode conversion windows [7, 8] and additionally microwave bursts during ELMs [9]. In active probing mode SAMI has been used

to record the edge magnetic pitch angle on MAST at multiple radial locations in the plasma [10, 11]. The system was subsequently moved to NSTX-U where the pitch angle measurements were repeated. These results demonstrated the feasibility of 2D DBS for measuring the magnetic pitch angle and motivate the construction of a production quality diagnostic, the SAMI-Upgrade.

3 System overview

A block circuit diagram of the SAMI-U radio frequency (RF) and digitisation system can be seen in figure 1. The antenna feed is connected to a balun on the RF PCB module, highlighted in green, which is situated perpendicular to the antenna PCB. The signal is amplified before passing through a power divider into IQ mixers at the fundamental. These two mixers combine the antenna signals with two local oscillator signals in the channel frequency range 10 – 40 GHz. The IF is band pass filtered between 1 MHz, to block leakage from the LO signal, and 25 MHz, to prevent aliasing; this is under half of the ADC sampling rate of 65 MS s^{-1} . The upper frequency of the band pass filter is kept below the Nyquist frequency to allow for the non-negligible frequency roll off of the filter.

Coaxial cables connect the RF modules to the digitisation system where first the signal is converted by an ADC. The digital output is processed by an FPGA. SAMI-U will produce over 16 GB s^{-1} of data throughout a plasma shot, which is processed into Ethernet packets and sent over multiple 10 Gbps fibre links to the data storage machine.

*e-mail: j.allen@york.ac.uk

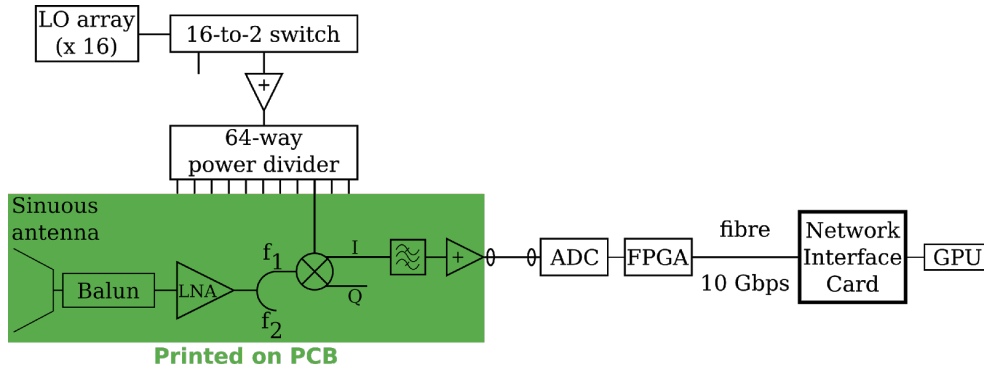

Figure 1. A block circuit diagram of the circuitry for one of two antenna polarisations in the SAMI-U array. Repeating sections have been omitted. The components in the green section will be printed or surface mounted on PCB which will feed the IF into the digitisation system.

Using this method SAMI-U can accommodate planned increases in pulse length on MAST-U and is only limited by the amount of RAM available in the storage machine. GPUs will be used in future for real-time calculation of the edge current density which could allow SAMI-U to become part of the set of feedback control diagnostics.

4 The sinuous antenna array

There are several constraints affecting the SAMI-U array design, the most restrictive of which is the 160 mm port window diameter which sets the maximum array diameter. This limits the number of antennas of a given size that can be contained while retaining independent baselines. In order to cover as much of the pedestal as possible, the antennas should be wide-band to encompass frequencies over at least one octave in the frequency range 10 – 40 GHz. To enable separation of O- and X-mode radiation they must be dual-polarisation. A planar structure would protect against spurious reflections within the array.

The sinuous antenna is the top candidate when considering all of these requirements and furthermore it is especially compact, a diameter of 13 mm is required to reach a low end frequency of 10 GHz. Its dual-polarisation log-periodic structure is shown in figure 2 with an example symmetric feed for both pairs of arms in the centre. The arms interleave to enable the dual-polarisation capability and each polarisation will be printed on either side of a PCB. Due to the top frequency of 40 GHz, the central area in which to extract the signals is small. Therefore, designing the geometry of this feed network is the biggest challenge when working with sinuous antennas at these frequencies.

SAMI-U will be situated at the midplane out of vacuum behind a port window of diameter 160 mm and its antenna array has a 150 mm diameter to retain an antenna field of view of $\pm 40^\circ$ in both the horizontal and vertical directions, accounting for the window thickness. Each of the 32 antenna elements requires a circular area of diameter 15 mm, including 2 mm of substrate free from copper surrounding the antenna arms. The antennas may not overlap one another and must lie wholly within the array PCB.



Figure 2. A dual-polarisation sinuous antenna, vertical polarisation in green and horizontal polarisation in purple. The log-periodic structure of the sinuous antenna offers a relatively small diameter for the low end frequency compared with other antennas and enables two polarisations to interleave. An array of sinuous antennas will not suffer from internal reflections due to their planar shape. At the desired maximum frequency, 40 GHz, the central feed region becomes very small making the design of the feed network the most complex part of the design. The feed design is omitted here so as not to prejudice future publications.

When arranging the original SAMI array, a simulated annealing optimisation method was used to minimise the sidelobe level of the array response to a point source [12]. However, the SAMI-U element placement will be chosen from a set of random placements as the benefit of using an optimisation algorithm in this case is unlikely to be worth the computational expense. Figure 3 shows an example antenna arrangement. The response of this array to a point source is displayed in figure 4.

All the sidelobes are below -18 dB making uncertainty due to these spurious signals sufficiently small in relation to the real backscattered signal. This is significantly below the maximum sidelobe of over -7 dB in the comparable response of the existing SAMI system, displayed in figure 5.

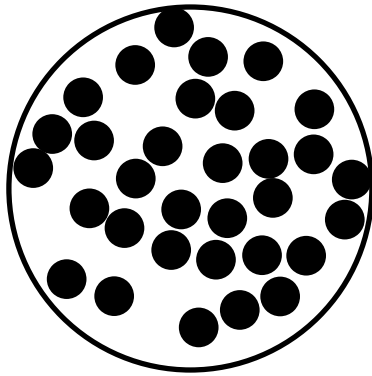

Figure 3. An example SAMI-U array layout. Ideally the layout should be maximally random in order to maximise the number of independent baselines and thus give the maximum amount of unique information in Fourier space. This is a random antenna arrangement with the lowest sidelobe level from a set of 10,000 candidate arrangements. The computational expense of optimising the placement of the 32 elements is likely to be prohibitive.

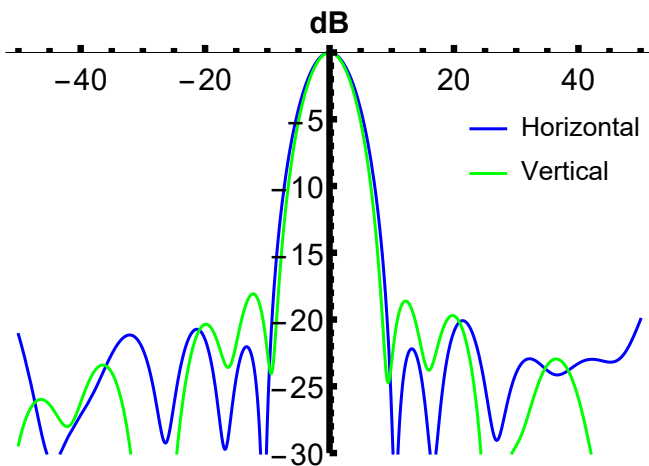

Figure 4. Response of the SAMI-U candidate array in figure 3 to a point source at $(\theta, \phi) = (0, 0)$ at frequency 16 GHz. The maximum sidelobe is below -18 dB in both the horizontal (blue) and vertical (green) planes.

5 Conclusion

Components for the SAMI-U diagnostic are being designed and built with the view to installing the completed system on MAST-U in time for the first experimental campaign. This device will extend the capability of the SAMI diagnostic to measure magnetic pitch angle at multiple radial locations to give the edge current density profile. The evolution of these current density profiles will aid understanding of edge instabilities including ELMs.

6 Acknowledgements

The authors would like to thank the Fusion CDT, EUROfusion and the EPSRC for supporting this research. This work was funded by the EPSRC under grant

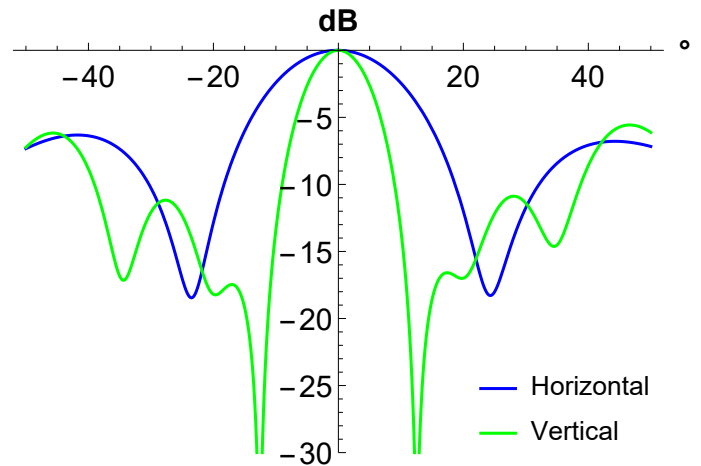

Figure 5. Response of the SAMI array to a point source at $(\theta, \phi) = (0, 0)$ at frequency 16 GHz. The maximum sidelobe is above -7 dB in both the horizontal (blue) and vertical (green) planes.

EP/L01663X/1.

References

- [1] A. Loarte, G. Saibene, R. Sartori, D. Campbell, M. Becoulet, L. Horton, T. Eich, A. Herrmann, G. Matthews, N. Asakura et al., *Plasma Physics and Controlled Fusion* **45**, 1549 (2003)
- [2] J.W. Connor, A. Kirk, H.R. Wilson, S. Benkadda, *AIP Conference Proceedings* **1013**, 174 (2008)
- [3] D.M. Thomas, A.W. Leonard, H.W. Mueller, *Review of Scientific Instruments* **75**, 4109 (2004)
- [4] D.M. Thomas, A.W. Leonard, R.J. Groebner, T.H. Osborne, T.A. Casper, P.B. Snyder, L.L. Lao, *Physics of Plasmas* **12**, 1 (2005)
- [5] M.F.M. De Bock, J. Citrin, S. Saarelma, D. Temple, N.J. Conway, A. Kirk, H. Meyer, C.A. Michael, *Plasma Physics and Controlled Fusion* **54**, 025001 (2012)
- [6] E. Viezzer, R. Dux, M. Dunne, *Review of Scientific Instruments* **87**, 11E528 (2016)
- [7] V.F. Shevchenko, R.G.L. Vann, S.J. Freethy, B.K. Huang, *Journal of Instrumentation* **7**, P10016 (2012)
- [8] S.J. Freethy, B.K. Huang, V.F. Shevchenko, R.G.L. Vann, *Plasma Physics and Controlled Fusion* **55**, 124010 (2013)
- [9] S.J. Freethy, V.F. Shevchenko, B.K. Huang, R.G.L. Vann, *Localised microwave bursts during ELMs on MAST*, in *EPJ Web of Conferences* (EDP Sciences, 2015), Vol. 87, p. 03008
- [10] D.A. Thomas, K.J. Brunner, S.J. Freethy, B.K. Huang, V.F. Shevchenko, R.G.L. Vann, *Nuclear Fusion* **56**, 026013 (2016)
- [11] R.G.L. Vann (2018), 20th Joint Workshop on Electron Cyclotron Emission (ECE) and Electron Cyclotron Resonance Heating (ECRH)

- [12] S.J. Freethy, V.F. Shevchenko, R.G.L. Vann, IEEE Transactions on Antennas and Propagation **60**, 5442 (2012)