



This is a repository copy of *A decision-making framework for the implementation of remanufacturing in rechargeable energy storage system in hybrid and electric vehicles.*

White Rose Research Online URL for this paper:
<http://eprints.whiterose.ac.uk/143498/>

Version: Published Version

Article:

Okorie, O., Turner, C., Salonitis, K. et al. (4 more authors) (2018) A decision-making framework for the implementation of remanufacturing in rechargeable energy storage system in hybrid and electric vehicles. *Procedia Manufacturing*, 25. pp. 142-153. ISSN 2351-9789

<https://doi.org/10.1016/j.promfg.2018.06.068>

Article available under the terms of the CC-BY-NC-ND licence
(<https://creativecommons.org/licenses/by-nc-nd/4.0/>).

Reuse

This article is distributed under the terms of the Creative Commons Attribution-NonCommercial-NoDerivs (CC BY-NC-ND) licence. This licence only allows you to download this work and share it with others as long as you credit the authors, but you can't change the article in any way or use it commercially. More information and the full terms of the licence here: <https://creativecommons.org/licenses/>

Takedown

If you consider content in White Rose Research Online to be in breach of UK law, please notify us by emailing eprints@whiterose.ac.uk including the URL of the record and the reason for the withdrawal request.



eprints@whiterose.ac.uk
<https://eprints.whiterose.ac.uk/>



8th Swedish Production Symposium, SPS 2018, 16-18 May 2018, Stockholm, Sweden

A Decision-Making Framework for the Implementation of Remanufacturing in Rechargeable Energy Storage System in Hybrid and Electric Vehicles

*O. Okorie¹, C. Turner¹, K. Salonitis¹, F. Charnley², M. Moreno², A. Tiwari³,
W. Hutabarat³

¹*Cranfield University, School of Aerospace, Transport and Manufacturing,
Bedfordshire, United Kingdom*

²*Cranfield University, Centre for Competitive Design, School of Water, Energy and Environment,
Bedfordshire, United Kingdom*

³*University of Sheffield, Department of Automatic Control & Systems Engineering,
Sheffield, United Kingdom.*

*Corresponding author: o.s.okorie@cranfield.ac.uk

Abstract

As data from manufacturing and digital intelligence become a pervasive feature of our economy, it becomes increasingly important to leverage on this data in the creation of new forms of value. Within emerging concepts such as Industry 4.0 (I4.0) and the Internet of Things (IoT), understanding decision-making and stakeholders' interaction is important in optimising manufacturing and post-manufacturing processes. Of interest is the post-manufacturing phase for the Rechargeable Energy Storage system, (RESS), a battery system embedded in hybrid and electric automobiles. This research develops a decision-making framework for the RESS component, employing data-driven remanufacturing as the circular approach for implementation. Findings highlight useful manufacturing data employed in remanufacturing for the RESS technology. This study concludes by giving recommendations on how decisions made by stakeholders and their interaction can inform manufacturers on design for remanufacturing.

© 2018 The Authors. Published by Elsevier B.V.
Peer-review under responsibility of the scientific committee of the 8th Swedish Production Symposium.

Keywords: Remanufacture, Rechargeable Energy Storage System, Circular Approach, Decision-Making, Internet of Things

1. Introduction

An increasingly important component of the circular economy, product remanufacturing is defined as returning an already used product to at a state closer to original equipment manufacturer (OEM) specification or a much better state [1]. Here the used product is returned to “at least its original performance with a warranty that is equivalent to or better than that of the newly manufactured product”, a British Standards Institution definition, [2]. Thus, for a remanufactured product to be deemed “acceptable”, the declaration of acceptability must come from what is the customer’s viewpoint and may not use repaired or reconditioned parts during the process of remanufacturing. Remanufacturing is no new concept; it is a process that culminated as an industrial activity during the Second World War with the remanufacturing of war tanks due to shortage of raw materials to manufacture new products, [3]. Academic interest in remanufacturing began in 1984 with a research by Robert Lund, [4] where the remanufacturing in the United States and its implications for developing countries in the European Union was studied. Remanufacturing in European countries was driven by environmental legislation and, similarly China, where the concern for environmental impacts caused by vehicles led to initiatives around remanufacturing, [3]. Besides the need to meet environmental concerns and ensure sustainability in the light of climate change, the major drivers for remanufacturing include end-of-life directives, economics, [1], improving productivity [3] and, as remanufacturing is labour intensive, it is seen as an assured employer of low-skilled labour[5]. An example of the positive environmental impact of remanufacture is indicated in a research on remanufacturing by Robert Lund. His research [4] shows that in comparison to equivalent new products, remanufacturing requires 50-80% less energy to produce a component and can provide 20-80% production cost savings. Remanufacturing, thus, has positive impacts on all three pillars of the circular economy –economic, environmental and societal. Figure 1 shows the research focus of the paper.

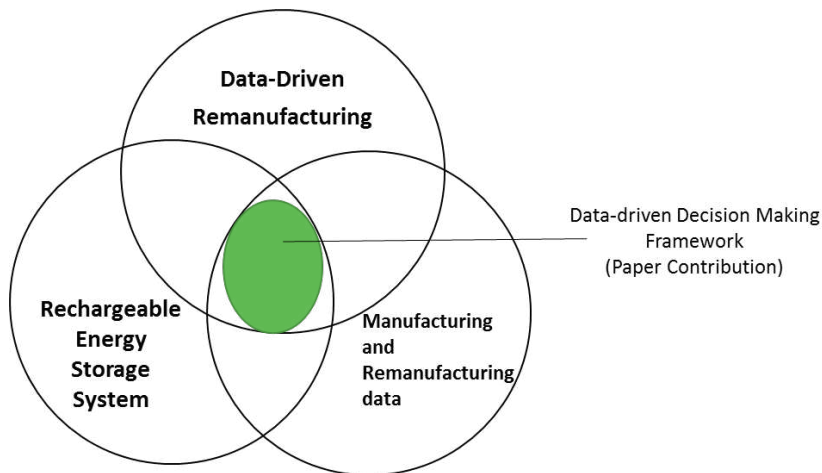

Fig 1: Research Focus

Unlike the concepts of remanufacturing and reverse logistics which has gained popularity in research, available theory on strategic decision-making for remanufacturing is limited [6]. Literature on strategic decision-making for remanufacturing HEVs and EVs is limited and literature on strategic decision-making for RESS remanufacture are not available at the time of writing this paper. This paper aims to contribute to this research gap. This research also aims to identify the manufacturing data which enables strategic decision-making for remanufacturing the RESS.

The automotive sector, where this research shall focus on is one of the primary industries where remanufacturing is done. The Centre for Remanufacture and Reuse, [2], also identifies aerospace, rail, mechanical power machinery,

ICT, rubber products and maritime sectors as major sectors out of 22 investigated which had remanufacturing activity in the United Kingdom. The automotive sector was seen to have one of the largest economic impact in remanufacturing and has been an area of interest for industry and academia, [3], [5] [7] and [6]. As innovation, the gradual decline in global oil reserves, stringent emission rules around the world and all-round environmental sustainability drive car manufacturing from the more traditional fuel-driven cars to hybrid and electric vehicles, the importance of understanding and developing appropriate post-manufacturing frameworks for critical parts of these new vehicles becomes imperative. This paper presents the development of a decision-making framework utilized in enabling the remanufacturing of the Rechargeable Energy Storage System, indicating where necessary, the manufacturing data needed to enable these decisions. This study will conclude by giving recommendations on how the decision made by stakeholders and their interaction can inform manufacturers regarding design for remanufacturing.

2. State of the Art

2.1. Remanufacturing

Simply put, remanufacturing is a process of disassembly and recovery of an asset at a product and component level, [8]. The product is disassembled, cleaned, refurbished, replaced as necessary and then reassembled, with the eventual performance of the product equal to or better than, “as new” through remanufacturing. Thus, the value of the product is retained, as the performance is at least as new and waste is minimized. Remanufacturing is a dominant feature of the “take, make, reuse” (TMR) model of the Circular Economy, which keeps product at their highest utility and value at all times, [9].

This research shall focus on automobile components where, presently, engine, fuel system, drive train components are some of the components remanufactured, with or without the knowledge of the customer, [10]. Remanufacturing is either performed by the OEM or the Independent Remanufacturer, with various advantages. While the OEM can leverage upon product knowledge and brand name, the independent remanufacturer has better accessibility to cores, often come with extensive expertise in remanufacturing and has dedicated facilities for remanufacture, [3]. Figure 2 below from [11] shows the remanufacture process, and Figure 3, a picture of a typical remanufactured product, [5].

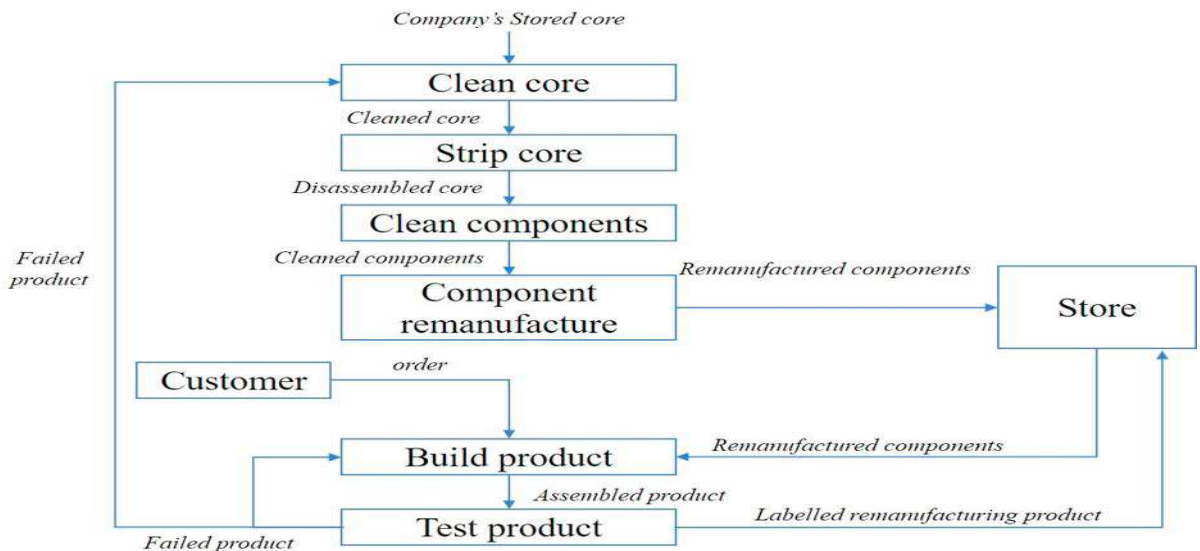

Fig. 2: A generic remanufacturing process chart, [11]



Fig 3: Example of core (L) and remanufactured (R) products, [5]

The drive towards circular model in manufacturing, achieving sustainable business plans and environmental legislation has driven recent industry and academic interest in remanufacturing. Research on remanufacturing has focused on utilising remanufacturing to enable reverse logistics and supply chains, [12], [13], [14], design for remanufacturing, [2], [15], [16], [5] and different case studies of remanufacturing in automotive industries have been of interest in research. An exploratory study for instance, revealed that in Brazil OEM's involved in remanufacturing had more advantages than independent remanufacturing companies, regarding the relationship with used product suppliers, remanufacturing operation and marketing of the remanufactured product, [3], when two case study companies were analysed. On the other hand, results in the research by Ijomah and Chiodo, [17] indicated that remanufacturing is highly profitable in large and complex mechanical and electromechanical products but requires effective waste management. However, due to the recentness of the development of “green” vehicles, (battery electric vehicle in 2009; hybrid electric vehicle in 2010; plug-in hybrid vehicle in 2011; fuel cell electric vehicle in 2012, [18]) there has been few research on remanufacturing components of these type of vehicles. The paucity of remanufacturing research in these vehicles can also be attributed to the business models of OEMs involved in electric and hybrid vehicles, as these vehicles require heavy innovation and are hence, kept secret. This research shall explore the decision-making involved in remanufacturing the rechargeable energy storage system and shall bring a contribution to knowledge of what is a developing area.

2.2. Rechargeable Energy Storage System

Electric Vehicles (EVs) use was first prompted by the California Air Resources Board (CARB) as a response to pollution reduction from automobile users, [19]. The hybrid electric vehicle (HEV), where electric batteries and the internal combustion engine (ICE) are combined in one powertrain and the electric vehicle, (EV), have become an important option for reducing fuel consumption, improving fuel efficiency, replacing the diminishing reserves of oil and providing clean energy supply systems. This is important, as the impacts of climate change are deemed to be irreversible, [18] and hence, it is important for the world to have an ideal emissions free future based on sustainable energy, [20]. The focus on reducing emissions of harmful substances into the environment has concentrated, for most parts; on the transport industry as researches in this area in recent years has shown that the transport industry is a main contributor to emissions of toxic substances into the atmosphere, as they rely on fossil fuels. According to [21] the transport industry accounts for 55% of the world energy consumption and 30.9% of CO₂ gas emissions, driven by the high demand for fossil fuel by the transport sector. Figures 4 and 5 below from [22] graphically simplifies the levels of energy consumption by different sectors from 2010 with projections made till 2020.

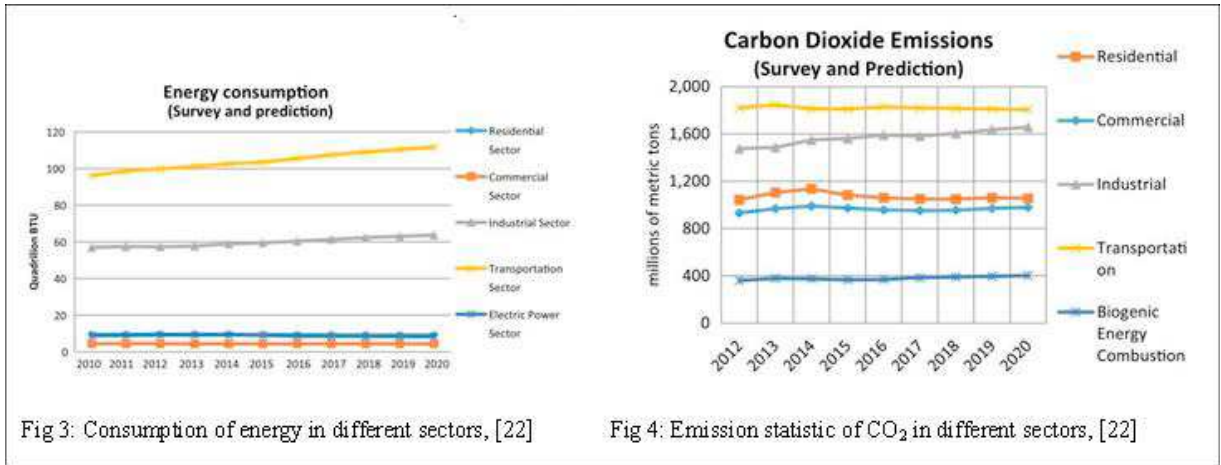

Fig 3: Consumption of energy in different sectors, [22]

Fig 4: Emission statistic of CO₂ in different sectors, [22]

Thus, it can be argued that attaining a sustainable future and reducing the effect of global warming is not completely possible until ways of tackling energy consumption by the transportation sector is investigated. Electric cars and hybrid vehicles are being explored as a sustainable alternative to the use of fossil fuels which normal traditional IC engine utilises. These environmentally friendly vehicles are driven by batteries, ultra-capacitors and fuel cells. Asides being environmentally friendly, electric cars help in reducing operational cost compared to fossil-fuelled vehicles, [18]. Most EVs and HEVs are powered by two energy storage devices. These are the “Main Energy System”, (MES) which has a high energy storage capability and the “Rechargeable Energy Storage System”, RESS, which has a high power capability and reversibility, [23] both part of the very complex systems of EVs/HEVs containing various subsystems, [19]. The Energy Storage Systems are made up of, Fuel Cells (FCs), Batteries and Supercapacitors (SCs) as shown in Figure 6 from [23].

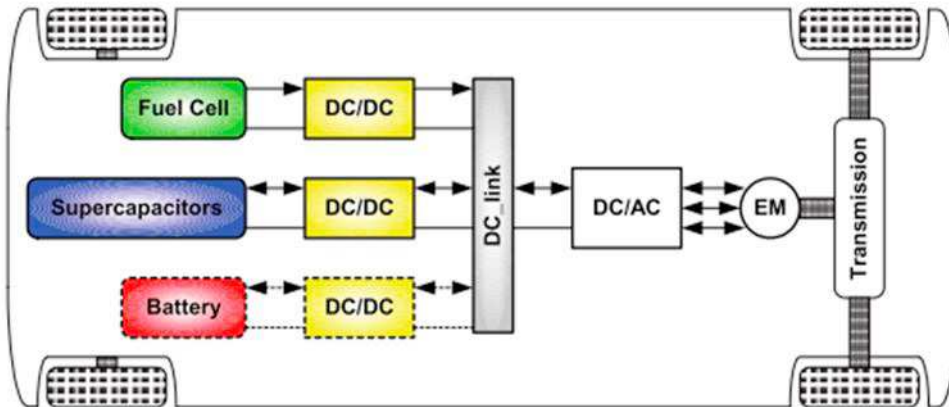

Fig 6: Drive System for Electric Vehicle, [23]

2.3. Decision Making for Remanufacturing in Automobiles

In exploring ways in which the electric vehicle can enable a transition to a circular economy, an ongoing focus in research has been the decision-making which influences remanufacturing, from the point of justifying a business case for the remanufactured component to remanufacturing the product. In exploring the need to combine ecological concerns and economic growth using remanufacturing [1] Ijomah discusses decision-making for remanufacturing

operations, as part of this exploration, by narrowing down on key decision-making in an international aero-engine manufacturer. In [6], Subramoniam, et al., developed a Remanufacturing Decision-Making Framework (RDMF) by identifying strategic remanufacturing factors identified during literature review of macro-level parameters in an automotive industry. This was further validated using the Analytical Hierarchal Process, (AHP) leading to prioritization of the RDMF. In a different research, Abdulrahman M.D., [24] developed a strategic decision-making framework which was further validated using the AHP. This study included qualitative data gathered from two leading Chinese auto-parts companies and the framework was developed around the key determinants for in-house remanufacturing, outsource remanufacturing and to not remanufacture.

3. Methodology

First an exploratory review of literature on the circular economy, remanufacturing, electric and hybrid vehicles was performed to understand the differences, meaning and impact on the remanufacturing process. Additionally, a literature review was done to understand the taxonomies of manufacturing data for automotive industry. The remanufacturing decision-making framework is also supposed to capture the type of data used in enabling these decisions, hence the need for the review.

The next step was selection of case study companies for applying this research. As the study is qualitative it is imperative to select companies that showed strong interest in remanufacturing and innovating from their current remanufacturing methods. First, a study of remanufacturing companies found on the database, “*European Remanufacturing Network*” (<http://www.remanufacturing.eu/>) was conducted. These companies were located in the “Case Study Tool” section of the website (<http://www.remanufacturing.eu/case-study-tool.php>), containing 66 company’s case studies within 10 key industry sectors. Important aspects of these companies such as, location”, “years of remanufacturing experience”, “access of data”, “availability of company website”, “involvement in sustainability”, “agreement to take part in the research” were noted. It was important, for instance, to have companies which were based in the United Kingdom as site visits were to be made. Of importance was the “*specialty*” of the companies. In order to have a more informed understanding of remanufacturing, companies involved in (i) automotive functions (ii) remanufacturing of mechanical products (iii) remanufacturing of electrical components (iv) companies involved in remanufacturing research and (v) companies involved with products that included HEVs, EVs, RESS and fuel cells were selected. These reduced the companies in the database from 64 to 4 companies. A 5th company, an OEM manufacturer and the client to a selected company, was provided by a selected company, an automotive remanufacturer. Thus the selected companies, included two OEM companies (Company C and Company E), two independents remanufacturers (one of electrical, Company D and the other of mechanical bias, PSS) and a company involved in remanufacturing (HSSMI) and research for remanufacturing RESS and fuel cells. Two of these companies were happy to be mentioned in the research and the other three remained anonymous. The depth in variety of the companies chosen and the different business models on which they operated, presented an important opportunity to understand similarities and investigate important differences, which are key in developing a framework that can be applicable to both EVs and HEVs.

A questionnaire and semi-structured interview were developed and deployed as qualitative research methods. First, subject areas for the questionnaire were developed from an understanding of the research objectives and the key terms related to the objectives. This questionnaire was explored questions under the following subject areas; (i) Circular Economy and Circular Approach; (ii) Decision-Making for the Circular Economy with the focus on Remanufacturing and (iii) Data and Data Streams flow for Remanufacturing. Multiple questions were developed under these groups after a review of literature and an initial discussion with the interviewees. The interview was in two parts: the first part of the interview captured general information about the company. The second part captured information regarding the use of manufacturing data in the process of manufacturing/ remanufacturing of these companies, stakeholders involved in remanufacturing, the business models of the companies and the processes involved in remanufacturing including any feedback loop. This questionnaire is given in Appendix A.

Respondents selected for the semi-structured interview were selected based on their years of experience, their importance in the remanufacturing process and decisions in the company and their understanding of the business models deployed in the companies. They were first contacted by email, where the initial introduction was done. A

follow-up phone call was then done. Following the first contact, a second email containing the questionnaire was sent to respondents, three days after the first contact. The respondents across the 5 companies included senior level managers and managing directors. These members of staffs were selected as they can provide a top view understanding for the research and were able to drill into the details, where necessary, as they had the knowledge, business and technical experience more than other employees. The data (completed questionnaire and semi-structured interview responses) were analysed to understand the how manufacturing data were utilized in remanufacturing and then to develop a decision-making framework for the RESS.

4. Results

The chart below in Figure 7 indicates the use of structured data, semi-structured data and unstructured data by the 5 case study companies.

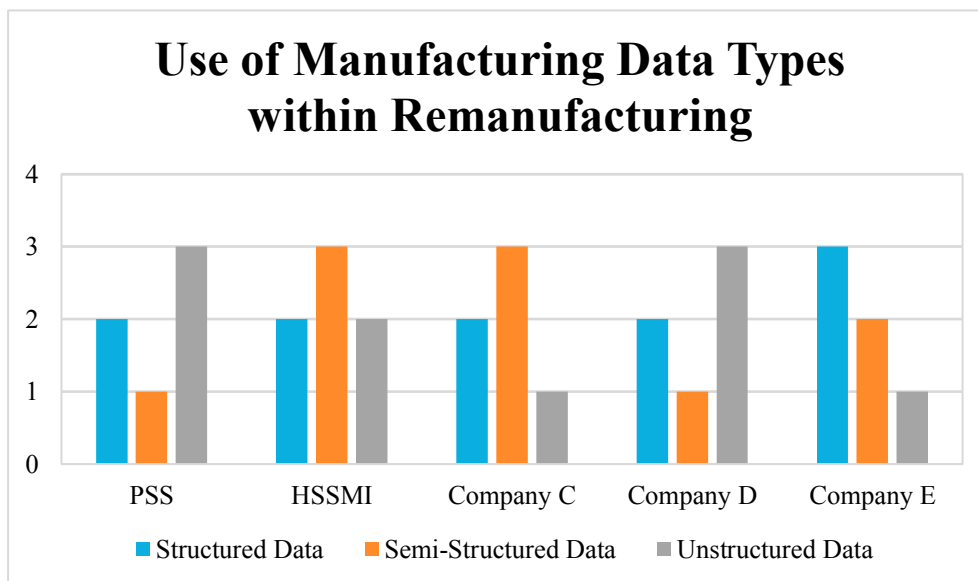

Fig 7: Use of Manufacturing Data by Case Study Companies

The taxonomy of manufacturing data was defined by three different categories. These are structured data (spreadsheets, relational databases, enterprise data warehouse, files stored in manufacturing PCs) real-time, semi-structured data (data from sensors, relays, RFID, XML, time series data structures) and unstructured data (operator shift reports, machine logs, error logs, texts, images, audio/video, manufacturing collaboration on social platforms), [25]. These were represented as “3” for “high”, “2” for “medium” and “1” for low, which denoted their level of use within the case study companies. It was observed that for Company C and HSSMI whose operations utilised a high level of automation and IoT interaction, employed a high amount of semi-structured data in comparison to PSS and Company D, both independent remanufacturers. Similar observations of data stream types were noticed in the development of the decision-making framework, which is given in Figure 8.

From the data gathered from the respondents, we develop the decision-making framework after identifying remanufacturing decision flow from the automobile manufacturer and the decisions taken to remanufacture by the third party independent remanufacturer, as well as the specific manufacturing data requirements that is needed to ensure the decision is carried out. This was developed after spending time with the OEM and third party remanufacturers and, with decision makers, agreeing on important decisions for remanufacturing, as due to the data

requirement and the technical robustness of the RESS, there were a host of decisions to make. The key driver that drove decision-making in remanufacturing is the ability to capture value either in the process or product or both process and product. This importance is useful, as decision-making in remanufacturing is a complex process as it normally involves at least two interacting constituents –the OEM and the Third Party Remanufacturer. In developing the decision-making framework, the following broad steps were carried out;

- a) Modelling an understanding of the decisions for the incoming product. Decisions of price, quality and quantity of incoming product, product assessment and pricing. Stakeholders, decision-makers and data requirements needed to enable this decision are captured and included in the model. It was observed that at this point companies also take into account economic, market, regulatory and environmental factors.
- b) Modelling the remanufacturing stages of the product after the decision has been made to remanufacture. This stage is conducted by the third party remanufacturer. Here the difference process of remanufacture and quality control audit check are captured and the stakeholders, decision-makers and the data needed to enable this decision are captured. These are modelled in input/output process boxes.
- c) Modelling the quality audit (if product is treated again after initial remanufacturer is complete) and the handover to the OEM. This stage contains another interaction between the third party remanufacturer and the OEM. The decision to send the product for recycling or other End-of- Life uses are captured here and the human and data drivers towards this decision are captured.

It was observed that remanufacturing decision-making framework for the RESS for EVs and HEVs would involve the interaction of stakeholders and manufacturing data between two hubs –the Automobile Manufacturer, or OEM and the independent remanufacturers. From the semi-structured interviews, independent remanufacturers are observed to be very experienced in remanufacturing, possess the necessary equipment for remanufacturing, were open to optimising manufacturing data for their remanufacturing needs and had a vast network of suppliers who help in remanufacturing. The decision to remanufacture is undertaken by the Head of Manufacturing at the OEM primarily based on business needs. Thus, this head of manufacturing is a senior level manager with a multi-disciplinary understanding of the business. The developed framework shows that there are interdependent interactions between stakeholders that inform decision making along the chain for effective remanufacturing. These interactions possess an inbuilt feedback mechanism which different stakeholders make use of in order to ensure that remanufacturing is done effectively. More importantly, it indicates loops where manufacturing data and data streams are important to accomplish remanufacturing. [6] argue that for effective remanufacturing decision-making to be employed, the strategic factors had to be as broad as possible. This framework highlights the importance of manufacturing data and data streams as part of that broad choice of parameters. Thus, from the developed framework, decision-making in remanufacturing for the RESS can be categorised into two different strategic components- the business level component at the OEM level and the engineering level component at the Independent Remanufacturer level. A balanced optimisation of these different levels is need for effective remanufacturing.

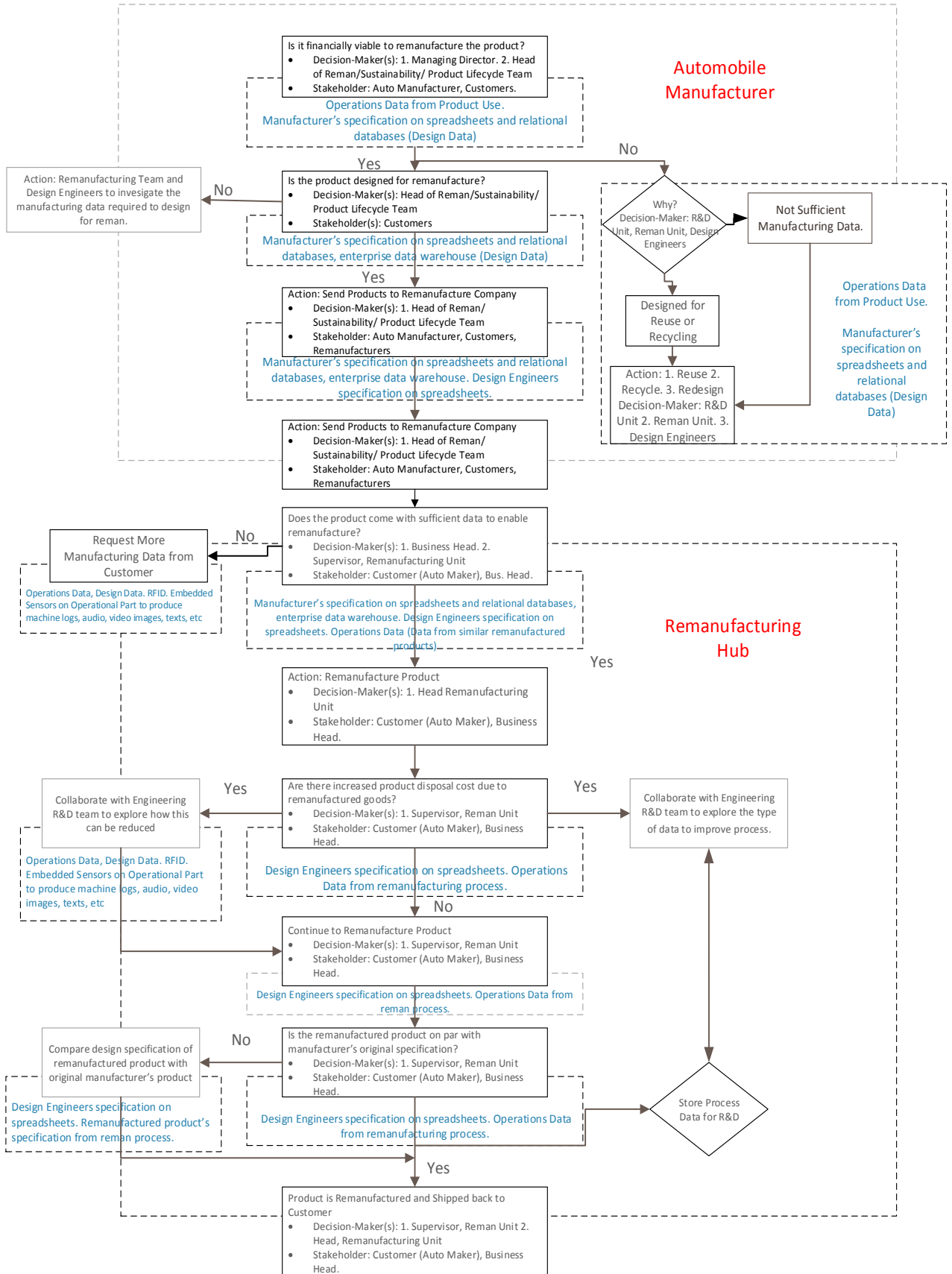

Fig 8: Remanufacturing Decision-Making Framework for the RESS

5. Discussion and conclusions

Remanufacturing is an important approach in attaining a more circular economy and has seen an upward growth owing to its main advantages –low cost and its ability to produce equipment and parts which at as new as or better than the original product. As it is labour intensive, it is also a job-creator; it directly employs over 480K people in the US alone from over 73K firms,[26] . It is an important end of life strategy for automobile parts and is expected to drive sustainability in EVs and HEVs, as these become a major part of transportation across the globe due to their green-energy ability in comparison to internal combustion-driven engines.

This paper aims to develop a decision-making framework for the rechargeable energy storage system, which is a key energy system currently utilised in Electric Vehicles (EVs) and Hybrid Electric Vehicles (EVs) with a focus on the key stakeholders and their decision and the manufacturing data utilised in the decision-making process. The novelty of this developed framework lies in the identification of exact data type and data sets required to enable remanufacturing, hence “*data-driven remanufacturing*”. To the best of the researchers’ knowledge, no decision-making framework captures this specific information.

The manufacturing data was highlighted due to the digital intelligence capacity of the modern EVs and HEVs, which are able to churn a vast amount of data and IoT communications and feedbacks that take place. Decision-making frameworks developed in research were drawn from automobile case study companies which produced the traditional IC-engine automobile and did not consider the manufacturing data utilized in production. The data for this research was collected from 5 different companies –much larger than similar remanufacturing decision-making framework research. The developed framework argues that the interdependencies between stakeholders is strategic for remanufacturing the RESS, due to the complexity of the RESS equipment and the type of data produced, must continue to ensure the effective delivery of remanufacturing. Feedback loops in the framework as seen to be as important as the decisions themselves as they contribute to the eventual remanufactured product quality. Further-work on this research includes validation of the decision-making framework; a TO-BE decision-making framework shall be developed after this validation. Validation methods will include data collection from Company C; the researchers shall spend some periods at the case company of this framework includes spending periods at Company C and PSS where both qualitative (semi-structured interview) and quantitative data shall be collected and analysed. Systems Dynamics and Discrete Event Simulation can be applied for validation if known elements (such as can be obtained from the remanufacturing shop-floor. This type of validation is important in order to capture the time element in data-driven remanufacturing. A criticality assessment of the decision-making framework shall be conducted, where the time and cost element of the key decisions shall be investigated and ranked. Viability of this decision-making frameworks to circular business models is an area worth investigating as future work. As innovation continues on the EVs and HEVs, further work includes development of important circular-economy enabling frameworks for the different components in the powertrain. Part of these further works includes, investigating more important and viable end-of-life uses of the data produced by the IoT devices which these EVs and HEVs are/ can be connected to. Future work should involve, as well, utilizing this framework as a driver for the development of an expansive design for data-driven remanufacturing methodology.

Acknowledgements

The authors wish to acknowledge the assistance of PSS, Norwich, and HSSMI, London, Riversimple, Wales, all in the United Kingdom for their contribution to this research as well as other companies who remained anonymous. The authors also wish to acknowledge the assistance of the EPSRC funded Network Plus, Connected Everything: Industrial Systems in the Digital Age, who contributed funding for this research.

Appendix A: Interview guide.

A.1 *Circular Economy: Fundamental Information*

1. What is your understanding of Circular Economy, Circular Approaches and Sustainability?
2. Why the choice of remanufacturing over recycling, reuse or another end-of-life approach? What is the most significant challenge in implementing remanufacturing in your firm?
3. What asset is being remanufactured? What drives this choice of asset?
4. How is remanufacturing being implemented in your firm? In-house or through a third-party remanufacturer? Why use a third-party remanufacturer? Why in-house remanufacturing? What are the barriers to implementing one over the other?

A.2 *Decision-Making for the Implementation of Remanufacturing*

1. How are decisions made for remanufacturing currently done? What drives the decision-making?
2. Who is the primary stakeholder for remanufacturing? Who are the key stakeholders for these decisions? What are the stakeholder interactions?
3. What are the important feedback loops that ensures remanufacturing is carried out?
4. What are the data type that drives remanufacturing decisions? Where is the data type most visible in?
5. What do you think data can do which is not currently doing?

A.3 *Data and Data streams for Data-Driven Automotive Remanufacturing*

1. What data are currently being considered for remanufacturing at present? How are these data captured?
2. What sensors are used for data capturing?
3. How do availability or lack of data improve the quality and speed of remanufacturing? What drives decisions without the availability of data?
4. Is there any tradeoff between quality and speed from the perspective of the customer?
5. How does data ownership affect decision-making for remanufacturing the RESS?

References

- [1. Ijomah WL. Addressing decision making for remanufacturing operations and design-for-remanufacture. *International Journal of Sustainable Engineering*. 2009; 2(2): 91–102. Available at: DOI:10.1080/19397030902953080
2. David Parker. *Remanufacturing in the UK*. Centre for Remanufacturing & Reuse. 2010;
3. Saavedra YMB., Barquet APB., Rozenfeld H., Forcellini FA., Ometto AR. Remanufacturing in Brazil: Case studies on the automotive sector. *Journal of Cleaner Production*. Elsevier Ltd; 2013; 53: 267–276. Available at: DOI:10.1016/j.jclepro.2013.03.038
4. Lund RT and BM. Remanufacturing: The experience of the United States and implications for developing countries. 1984; (31): 126. Available at: <http://documents.worldbank.org/curated/en/792491468142480141/Remanufacturing-the-experience-of-the-United-States-and-implications-for-developing-countries>
5. Tolio T., Bernard A., Colledani M., Kara S., Seliger G., Duflo J., et al. Design, management and control of demanufacturing and remanufacturing systems. *CIRP Annals - Manufacturing Technology*. 2017; 66(2): 585–609. Available at: DOI:10.1016/j.cirp.2017.05.001

6. Subramoniam R., Huisingsh D., Chinnam RB., Subramoniam S. Remanufacturing Decision-Making Framework (RDMF): Research validation using the analytical hierarchical process. *Journal of Cleaner Production*. 2013; 40: 212–220. Available at: DOI:10.1016/j.jclepro.2011.09.004
7. Ramoni M., Zhang HC. Remanufacturing processes of electric vehicle battery. *IEEE International Symposium on Sustainable Systems and Technology*. 2012; 147(2005): 2005. Available at: DOI:10.1109/ISSST.2012.6228014
8. Ellen Macarthur Foundation. INTELLIGENT ASSETS: UNLOCKING THE CIRCULAR ECONOMY POTENTIAL. 2016.
9. Ellen MacArthur Foundation. *Towards The Circular Economy*. 596/09-08-2013. 2013.
10. Sutherland JW., Adler DP., Haapala KR., Kumar V. A comparison of manufacturing and remanufacturing energy intensities with application to diesel engine production. *CIRP Annals - Manufacturing Technology*. 2008; 57(1): 5–8. Available at: DOI:10.1016/j.cirp.2008.03.004
11. Ijomah WL., McMahon CA., Hammond GP., Newman ST. Development of design for remanufacturing guidelines to support sustainable manufacturing. *Robotics and Computer-Integrated Manufacturing*. 2007; 23(6): 712–719. Available at: DOI:10.1016/j.rcim.2007.02.017
12. Nenes G., Panagiotidou S., Dekker R. Inventory control policies for inspection and remanufacturing of returns: A case study. *International Journal of Production Economics*. Elsevier; 2010; 125(2): 300–312. Available at: DOI:10.1016/j.ijpe.2010.02.008
13. Vlachos D., Georgiadis P., Iakovou E. A system dynamics model for dynamic capacity planning of remanufacturing in closed-loop supply chains. *Computers and Operations Research*. 2007; 34(2): 367–394. Available at: DOI:10.1016/j.cor.2005.03.005
14. Bhakthavatchalam S., Diallo C., Venkatadri U., Khatib A. Quality, reliability, maintenance issues in closed-loop supply chains: A review. *IFAC-PapersOnLine*. Elsevier Ltd.; 2015; 28(3): 460–465. Available at: DOI:10.1016/j.ifacol.2015.06.124
15. Butzer S., Schötz S., Steinhilper R. Remanufacturing Process Assessment - A Holistic Approach. *Procedia CIRP*. The Author(s); 2016; 52: 234–238. Available at: DOI:10.1016/j.procir.2016.07.066
16. Esmaeilian B., Behdad S., Wang B. The evolution and future of manufacturing: A review. *Journal of Manufacturing Systems*. 2016; 39: 79–100. Available at: DOI:10.1016/j.jmsy.2016.03.001
17. Ijomah WL., Chiodo JD. Application of active disassembly to extend profitable remanufacturing in small electrical and electronic products. *International Journal of Sustainable Engineering*. 2010; 3(4): 246–257. Available at: DOI:10.1080/19397038.2010.511298
18. Wilberforce T., El-Hassan Z., Khatib FN., Al Makky A., Baroutaji A., Carton JG., et al. Developments of electric cars and fuel cell hydrogen electric cars. *International Journal of Hydrogen Energy*. Elsevier Ltd; 2017; 42(40): 25695–25734. Available at: DOI:10.1016/j.ijhydene.2017.07.054
19. Kouchachvili L., Yaïci W., Entchev E. Hybrid battery/supercapacitor energy storage system for the electric vehicles. *Journal of Power Sources*. 2018; 374(November 2017): 237–248. Available at: DOI:https://doi.org/10.1016/j.jpowsour.2017.11.040
20. Heppeler G., Sonntag M., Wohlhaupter U., Sawodny O. Predictive planning of optimal velocity and state of charge trajectories for hybrid electric vehicles. *Control Engineering Practice*. Elsevier Ltd; 2017; 61: 229–243. Available at: DOI:10.1016/j.conengprac.2016.07.003
21. Wilberforce T., Alaswad A., Palumbo A., Dassisti M., Olabi AG. Advances in stationary and portable fuel cell applications. *International Journal of Hydrogen Energy*. Elsevier Ltd; 2016; 41(37): 16509–16522. Available at: DOI:10.1016/j.ijhydene.2016.02.057
22. Das HS., Tan CW., Yatim AHM. Fuel cell hybrid electric vehicles: A review on power conditioning units and topologies. *Renewable and Sustainable Energy Reviews*. Elsevier Ltd; 2017; 76(January 2016): 268–291. Available at: DOI:10.1016/j.rser.2017.03.056
23. Al M., Van J., Gualous H. DC/DC Converters for Electric Vehicles. *Electric Vehicles - Modelling and Simulations*. 2011; (September). Available at: DOI:10.5772/17048
24. Abdulrahman MDA., Subramanian N., Liu C., Shu C. Viability of remanufacturing practice: A strategic decision making framework for Chinese auto-parts companies. *Journal of Cleaner Production*. Elsevier Ltd; 2015; 105: 311–323. Available at: DOI:10.1016/j.jclepro.2014.02.065
25. Intel Corporation. *Optimizing manufacturing with the internet of things*. Intel Corporation. 2014. Available at: <http://www.intel.com/content/www/us/en/internet-of-things/white-papers/industrial-optimizing-manufacturing-with-iiot-paper.html> (Accessed: 17 August 2016)
26. Hauser W., Lund R. *The Remanufacturing Industry: Anatomy of a Giant*, Report. Boston; 2003. Available at: <http://www.bu.edu/remman/OrderAnatomy.htm>