

**ASYMMETRICAL ADAPTATION OF  
HUMAN SACCADES TO  
ANISOMETROPIC SPECTACLES**



Print: Haveka B.V., Alblaserdam, The Netherlands.

Acknowledgement. These investigations were supported by the Foundation for Medical Research MEDIGON (grant nr.: 900-550-092).

**ASYMMETRICAL ADAPTATION OF  
HUMAN SACCADES TO  
ANISOMETROPIC SPECTACLES**

(ASYMMETRISCHE ADAPTATIE VAN  
MENSELIJKE SACCADES AAN  
ANISOMETROPE BRILLEN)

**PROEFSCHRIFT**

ter verkrijging van de graad van doctor  
aan de Erasmus Universiteit Rotterdam  
op gezag van de rector magnificus  
Prof. Dr. C.J. Rijnvos  
en volgens besluit van het college van dekanen.  
De openbare verdediging zal plaats vinden op  
woensdag 21 februari 1990 te 15.45 uur

door

**HANS GEERT LEMIJ**

geboren te Point Fortin (Trinidad)

1990

**Promotiecommissie:**

**Promotor: Prof. Dr. H. Collewijn**

**Overige leden: Prof. Dr. M.W. van Hof**  
**Prof. Dr. P.T.V.M. de Jong**  
**Prof. Dr. C.D.A. Verwoerd**

Aan Joke

Aan mijn ouders

De totstandkoming en verspreiding van dit proefschrift zijn mogelijk gemaakt mede dankzij:

Groeneveld Brillen  
Nederlands Kontaktlens Laboratorium  
Rodenstock/NEHOM

## DANKWOORD

Dit proefschrift is tot stand gekomen door de inzet van velen. Ieder van hen ben ik daarvoor zeer dankbaar. Diegenen die werkelijk onmisbaar zijn geweest wil ik graag in het bijzonder bedanken.

Prof. Dr. H. Collewijn. Han, bedankt voor de prettige en inspirerende manier waarop je mij begeleidt. Jouw kritische houding, jouw grote kennis van zaken en jouw gave om helder te schrijven, zullen een blijvend voorbeeld voor me zijn.

Prof. Dr. M.W. van Hof, Prof. Dr. P.T.V.M. de Jong en Prof. Dr. C.D.A. Verwoerd. Bedankt voor het kritisch doornemen van mijn proefschrift en voor uw bereidheid zitting te nemen in de promotiecommissie.

Dr. J. van der Steen en Dr. C.J. Erkelens. Hans en Casper, bedankt voor de vele uren die jullie besteed hebben aan het programmeren van de benodigde computerprogramma's. Van de leuke discussies met jullie heb ik erg veel geleerd.

Dank ben ik verschuldigd aan de tientallen proefpersonen die aan het onderzoek hebben deelgenomen. In het bijzonder wil ik proefpersonen JN en PF bedanken voor de schier eindeloze reeks van experimenten van Hoofdstuk 7.

Mw. S. Markestijn. Suzanne, jouw bijdrage aan het maken van de figuren is enorm geweest, zowel achter de PC, als in de doka. Nogmaals, bedankt.

Dr. Th. Stijnen wil ik hierbij bedanken voor het wegwijs maken in de variantie analyse.

Groeneveld Brillen B.V. Hartelijk bedankt voor het zoeken van geschikte proefpersonen en voor het leveren van diverse materialen. Kees Kortland, Joop Franken, Ruud van den Heuvel en Anne Smit, vooral jullie inzet heb ik erg op prijs gesteld.

Mw. J. van Werkum-van Gelder. Josanna, bedankt voor het minutieuze proeflezen en voor je lay-out adviezen.

Tot slot wil ik alle medewerkers van de afdeling Fysiologie I bedanken voor de leuke tijd die ik er gehad heb.





# TABLE OF CONTENTS

## CHAPTER 1 INTRODUCTION

Saccades	1
Control of saccades	2
Binocularity	3
Hering's law	3
Adaptation	3
Outline of the present thesis	5

## CHAPTER 2 REVIEW OF THE LITERATURE

Hering's law of equal innervation	7
Adaptation of saccades	9
Asymmetrical adaptation of saccades	13

## CHAPTER 3 GENERAL METHODS

Geometrical principles	17
The stimulus screen	25
Targets	26
Eye movement recording-technique	27
Calibration procedures	28

CHAPTER 4  
**DIFFERENCES IN ACCURACY OF HUMAN SACCADES  
BETWEEN STATIONARY AND JUMPING TARGETS**

Introduction	33
Methods	34
Results	37
Discussion	48

CHAPTER 5  
**CONJUGACY OF SACCADES**

Introduction	55
Methods	57
Results	61
Discussion	70

CHAPTER 6  
**LONG-TERM ASYMMETRICAL ADAPTATION**

Introduction	73
Fundamental considerations on spectacle-lenses	74
Methods	77
Results	79
Discussion	93

CHAPTER 7  
**SHORT-TERM ASYMMETRICAL ADAPTATION**

Introduction	99
Methods	99
Results	102
Discussion	114

CHAPTER 8  
**MERIDIAN-SPECIFIC ASYMMETRICAL ADAPTATION OF  
HORIZONTAL AND VERTICAL SACCADES**

Introduction	119
Methods	119
Results	122
Discussion	131

CHAPTER 9  
**MERIDIAN-SPECIFIC ASYMMETRICAL ADAPTATION OF  
OBLIQUE SACCADES**

Introduction	135
Methods	136
Results	142
Discussion	149

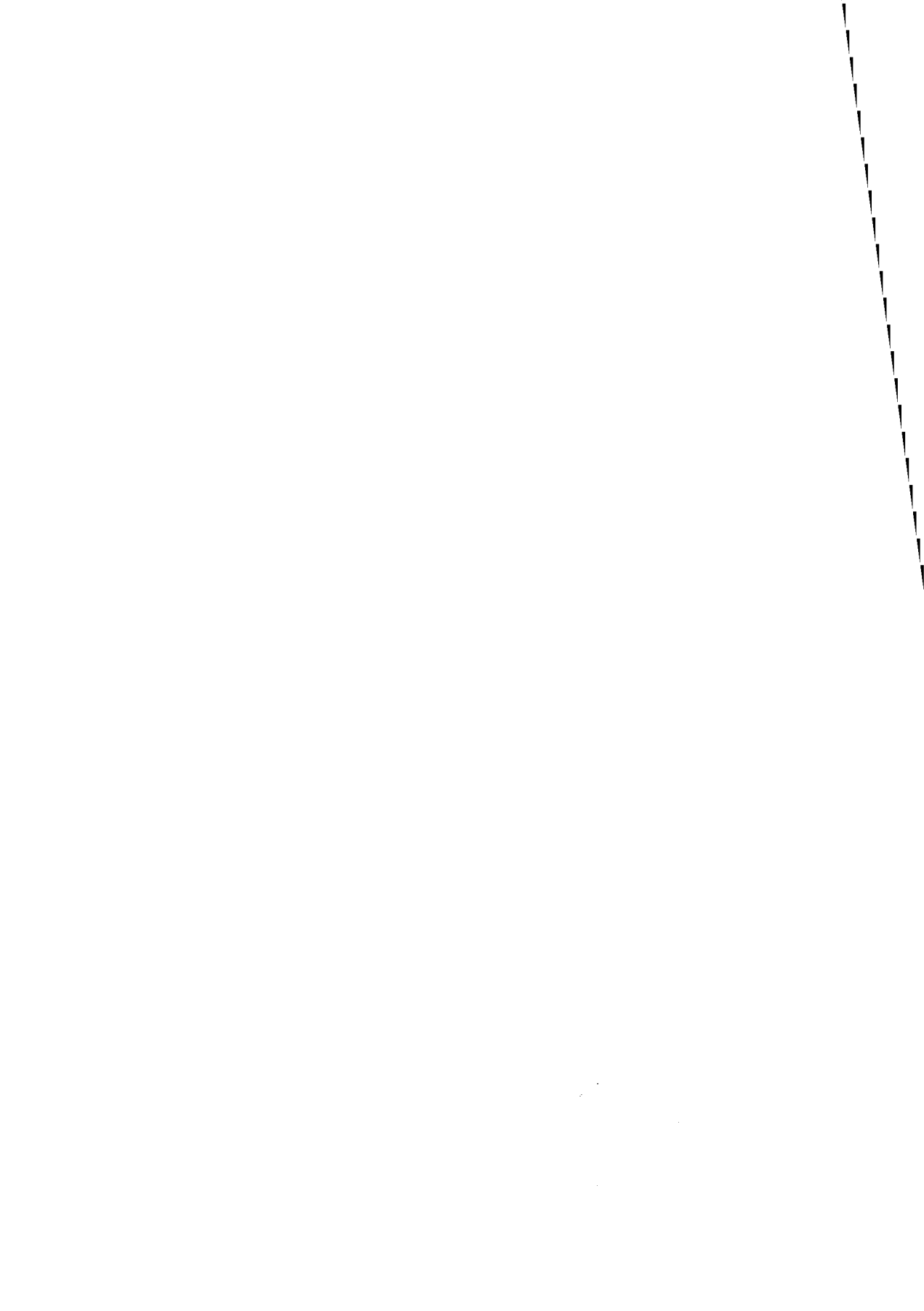
CHAPTER 10  
**GENERAL DISCUSSION AND CONCLUSIONS** 151

REFERENCES	161
------------	-----

SUMMARY	167
---------	-----

SAMENVATTING	173
--------------	-----

CURRICULUM VITAE	177
------------------	-----



## CHAPTER 1

### INTRODUCTION

#### SACCADES

Saccades are the rapid eye movements that allow us to voluntarily shift our gaze from one visual target to another. They serve to bring newly selected targets to the small and central area of the retina which is called the fovea, where visual acuity is high. The size of saccades can range between a minimum of about 3 min arc (Haddad and Steinman, 1973) up to a maximum of about 90 deg. Although saccades have been studied extensively under various experimental conditions, there are, to my knowledge, no reliable data on the metrics of normal human saccades, i.e., saccades we make in every-day life. However, it is generally assumed that most of our normal saccades have magnitudes of less than about 15 deg and that larger saccades are usually associated with movements of the head.

A prominent characteristic of saccades is that they are fast. They therefore enable us to direct our gaze over a wide range in a short period of time. Peak-velocities of saccades rise as the magnitudes of saccades become larger. This is a quite close relationship. At saccadic magnitudes larger than about 40 deg, the peak-velocities saturate. Peak-velocities may then reach values of up to about 600 deg/s (e.g. Westheimer, 1954; Boghen et al., 1974; Bahill et al., 1975a; Collewyn et al., 1988a,b). There is also a quite close relationship between the duration of a saccade and its magnitude in the sense that the execution of a large saccade takes more time than the execution of a small saccade. A saccade with a magnitude of 10 deg takes about 50 ms to be made, whereas a 40 deg saccade has a duration of about 130 ms. Another prominent characteristic of saccades is that they are remarkably accurate, despite their high velocities. Saccades are generally thought to fall short of their target by about 10% of the angular distance between the previous target and the new target. The residual error is compensated by so-called

corrective saccades. This 10% undershoot is, however, observed under rather unnatural experimental conditions. Collewyn et al. (1988a) showed recently that under more natural conditions, this undershoot was considerably less than 10%. I shall go further into this in *Chapter 4*.

## CONTROL OF SACCADES

The high accuracy of a saccade obviously requires a very strict control of its execution by the central nervous system, which drives the eye-muscles that move the eye in its orbit. The high velocities of saccades put special demands on this control, as will now be explained. When the eye makes a saccade, the visual image of the outside world on the retina sweeps with approximately similar velocity across the retinal surface. Because velocities of the retinal image higher than only a few deg/s degrade visual acuity, the central nervous system is very unlikely to receive useful visual feedback on the position of the target during a saccade. In addition, the time-delay associated with the transport of any in-flight visual information on the position of the target, and also the time required for the processing of that visual information, would be too long to adjust the trajectory of a saccade in time. Under certain experimental conditions, however, the trajectory of saccades can indeed be changed in mid-flight by retinal signals (Van Gisbergen et al., 1987).

In spite of the minor role, if any, of visual feedback during the execution of a saccade, saccades are remarkably accurate over the full range of magnitudes. Therefore, the trajectory of a saccade has to be accurately pre-programmed. Evidence is gathering that the central nervous system obtains non-visual, or extra-retinal, information on the positions of the eye during the execution of a saccade, primarily by keeping track of the actual motor commands to the eye-muscles (the so-called *effeference copy*) which, in turn, allows for the in-flight adjustment of deviations from the pre-programmed trajectory.

## BINOCULARITY

Because humans have two eyes with largely overlapping visual fields, it is important that each eye be always positioned in such a way that the image of a visual target lies, within certain limits of tolerance, on the fovea of each eye. This positioning of the two eyes is called binocular foveation. If a visual target were not binocularly foveated, each fovea would contain the image of a different visual object. This would presumably lead either to the perception of double images, or to the suppression of one of the two images, in which case we would effectively end up with monocular vision. In conclusion, if a visual target were not foveated binocularly, it would probably be more of a nuisance than of a benefit to have two eyes.

## HERING'S LAW

To maintain binocular foveation at all times, eye movements are generally thought to obey Hering's law of equal innervation. According to this law, the eyes make movements of equal size (Hering, 1868). A simple illustration of this law is that if one eye is covered, it apparently follows the movements of the viewing eye closely. However, the validity of this law was already challenged in Hering's time and it has been subject to debate for more than a century. I will elaborate on Hering's law and also on its violations in *Chapter 2*, because of its relevance to the present thesis.

## ADAPTATION

As already mentioned, the central nervous system presumably receives very little, if any visual feedback during the execution of a saccade. Because saccades are so very accurate, the central nervous system must be very well informed about the properties of the extra-ocular muscles, as well as about the forces of resistance that act on the eyeball during its movement, caused by the tissues in which the eye is suspended. As the eye-muscles that move the eye, as well as the tissues in which each eye is suspended are subject to change due to growth, ageing, disease or fatigue, the motor commands that drive the eye-muscles need to be recalibrated frequently, in order to make accurate

saccades possible throughout a person's entire life. The central nervous system itself is also subject to changes. Moreover, as all these changes will probably not have the same time-course and magnitude in the various parts of the eye movement system, a differential recalibration is required to adapt to these changes in an appropriate way for the eye movements to remain accurate. More specifically, changes that involve one eye more than the other eye, require *asymmetrical adaptations*.

An important question in the understanding of how the central nervous system adapts to these changes is how it keeps up-to-date with them. In physiological terms, what is the appropriate stimulus for these adaptations? A very likely candidate for such a stimulus is the visual information that reaches the central nervous system after the completion of each saccade. I hypothesize that the existence of any consistent discrepancy between the actual position of the eye at the end of a saccade, as judged from the visual information that enters the central nervous system, and the required position of the eye, forms the stimulus for adjusting the motor commands.

Changes caused by growth, ageing, disease or fatigue are obviously not restricted to the oculomotor system, but take place continuously in all parts of the body. How the central nervous system adapts to these changes is poorly understood. A close examination of adaptations to these changes by the eye movement system may contribute to the understanding of how the central nervous system is capable of responding to similar changes in the rest of the body.

Recently, Erkelens et al. (1989b) found that subjects made saccades of unequal size, thus violating Hering's law of equal innervation, after they had adapted to anisometric spectacles. These are spectacles that have lenses of unequal refractive powers, and therefore have unequal magnifying factors for each of the two eyes. Because such different magnifications of the visual world lead to images of different size in each eye, the appropriate adaptation to these spectacles would be a change in size between the movements of each of the two eyes. Such adaptations were already evident after wearing anisometric spectacles for about 8 hours.

In the present thesis, the asymmetrical adaptations to anisometric spectacles are studied and discussed in greater detail.



## OUTLINE OF THE PRESENT THESIS

In *Chapter 2*, a review of the relevant literature will be presented. It will focus primarily on the literature on asymmetrical adaptations of saccades both to changes caused by the wearing of spectacles and to pathological or experimental weakening of external eye-muscles. In addition, Hering's law will be commented on in detail.

The study of asymmetrical adaptation to anisometric spectacles requires accurate recordings of the movements of both eyes simultaneously. The geometrical principles, which underly a clear description of the recorded movements of each eye, will be discussed in detail in *Chapter 3*. This chapter will also deal with the materials that were used and the general methods that were employed in the experiments of the following chapters.

Saccades are usually elicited experimentally by having subjects make gaze shifts to suddenly moving targets. Because such an experimental design deals with saccades as if they are reflex-like movements, rather than voluntary movements to continuously present targets, as is the case in every-day life, the effects of the target condition on the execution of saccades, notably their accuracy, is examined and discussed in *Chapter 4*.

A way of measuring the amount of adaptation of saccades to anisometric spectacles, is to assess to what extent Hering's law is violated. This can be done by measuring the sizes of the saccades in each eye in monocular viewing. The change in size of the movements of the covered eye reflects the actual hard-programmed adaptation. In *Chapter 5* accurate baseline data are obtained of the movements of a covered eye before any adaptation has taken place.

*Chapter 6* presents data on the metrics of saccades in a number of subjects who have been wearing anisometric spectacles for many years. This chapter deals with the adaptations of horizontal and vertical saccades to the long-term wearing of such spectacles. *Chapter 7* focusses on the time-course and limits of short-term adaptation to anisometric spectacles. Both horizontal and vertical saccades will be examined. As different areas of the central nervous system are involved in the generation of horizontal

and vertical saccades, I address the question whether saccades can be selectively adapted in one eye and in one meridian (horizontal or vertical) only, without affecting saccades in the other eye and also without affecting saccades in the orthogonal meridian. This question is dealt with in *Chapter 8*. This chapter is followed by an assessment, in *Chapter 9*, whether adaptations to anisometric spectacles can be specific for any meridian, or whether such adaptations always consist of adaptations of the horizontal and the vertical components of oblique saccades. Finally, *Chapter 10* will present a general discussion of the main findings of the research described in this thesis.

## CHAPTER 2

### REVIEW OF THE LITERATURE

This review will be limited to the literature that is of direct relevance to the topic of asymmetrical saccadic adaptation. For a comprehensive survey of the oculomotor system, including the saccadic subsystem, see e.g. Carpenter (1988). A general overview of the literature on adaptations of eye movements, also other than saccades, is presented in Berthoz and Melvill Jones (1985). In the present chapter, I shall first go into Hering's law of equal innervation, because of its pertinence to the adaptation of saccades of two eyes. Secondly, I shall focus on the literature that deals with adaptation of saccades in general, and finally, I shall discuss the literature on the asymmetrical adaptation of saccades, i.e., adaptation of saccades that is different for each of the two eyes.

#### HERING'S LAW OF EQUAL INNERVATION

According to Hering (1868), the eyes move in such a perfectly coordinate way that the lines of sight of both eyes are always aimed at the same object. The two eyes can therefore, in Hering's terms, be thought of as one organ, which he named the double-eye (Doppelaue). Hering illustrated his concept of the double-eye with his observation that linking of the movements of the two eyes also occurs when there is no need for any linking, such as when one eye is covered. Hering believed that this coordinate linking was innate. His views contrasted sharply, however, with those of his contemporary scientific rival Helmholtz, who favoured the notion that each eye was innervated independently and that only through experience were coordinate movements achieved (see Bridgeman, 1977).

For eye movements in the horizontal meridian, each eye receives, according to Hering, two different innervations, each of which is equal for the two eyes. One innervation

results in a turning of both eyes to the right or left (*version*), and the other innervation results in an inward or outward turning of the eyes (*vergence*). Version movements are required for changes in *direction* of our gaze, whereas vergence movements are required for changes in *distance*. In Hering's terminology, vergence movements are therefore, by definition, movements of the two eyes in opposite direction, because, for a vergence movement, one eye moves to the left and the other eye moves to the right. Movements of the two eyes in a direction opposite to each other are frequently referred to as *disjunctive*, whereas movements of the two eyes in the same direction are called *conjugate*.

According to Hering, any movement of each of the two eyes is composed of a version movement that is equally large for each eye and a vergence movement that is also equally large for each eye. Hering pointed out that the magnitude of the net movement of one eye would be different from the magnitude of the net movement of the other eye if a gaze shift required both a change in direction and a change in distance. It is, however, a mathematical tautology to consider each eye movement to be the sum of a version and a vergence movement, because this is always true and cannot be violated (Ono, 1980; Erkelens et al., 1989a).

Hering's law should be seen in the light of its time, when eye movements had never been recorded. Only 35 years after Hering drew up his law of equal innervation did Dodge (1903) measure eye movements. In his classical paper, Dodge distinguished five types of eye movements. This classification has remained virtually the same over the years, although the nomenclature of these five types has changed somewhat. Dodge described a slow disjunctive eye movement (type 5), which is currently referred to as a vergence eye movement. It has been more or less tacitly assumed that the other four types of eye movements (one of which represents saccades) are conjugate. Because of the differences in dynamic properties of (fast) saccades and (slow) vergence eye movements, Hering's law has been frequently put to the test by examining whether normal eye movements can indeed be algebraically broken down to a slow, vergence eye movement and a fast, version (saccadic) movement.

Yarbus (1967) reported that eye movements that required both a change in direction and

a change in distance consisted indeed of the arithmetical sum of a (slow) vergence and a fast (saccadic) version eye movement. He stated that such composite eye movements were in fact triphasic: they consisted of an initial (slow) vergence movement, an additional fast saccadic version movement, followed by another (slow) vergence movement. Although Yarbus' experiment gained considerable popularity, more recent work showed, however, that slow vergence and fast saccadic eye movements are in fact not additive in tasks that require gaze shifts with changes both in direction and in distance (e.g. Ono et al., 1978; Ono and Nakamizo, 1978; Enright, 1984, 1986; Erkelens et al., 1989a). When a gaze-shift has to be made that requires both a change in direction and a change in distance, this gaze-shift can be brought about to a large extent by saccades that are of unequal size. These findings appear to undermine Hering's law of equal innervation.

However, Erkelens et al. (1989a) emphasized recently that the debate about the validity of Hering's law in the present century has presumably little to do with Hering's original ideas, because Hering never distinguished between different types of eye movements, simply because they were unknown at that time. The tenet of Hering's insight was, however, that the coordination of the two eyes is so good, that any selected target can be binocularly foveated at all times. To achieve this binocular foveation, the central nervous system has to take both changes in direction and changes in distance into account. In this sense, Hering's law is still valid.

## ADAPTATION OF SACCADDES

As explained in the previous chapter, the motor commands to the eye-muscles that move the eye in its orbit need to be recalibrated frequently throughout a lifetime, in order to respond adequately to changes that occur anywhere in the structures involved in the execution of eye movements. These changes are due to, e.g., growth, ageing, disease or fatigue. I also pointed out that saccades are so fast, that they are normally over before any useful visual feedback can affect their trajectories, which puts special demands on the control of saccades and also on the way the recalibrations take place. All these recalibrations are usually denominated by the word *adaptation*. Before going into the literature that deals with the adaptation of saccades, I shall discuss some of the

properties of the motor commands that generate saccades.

The discharge from the motoneurons that drive the eye muscles to generate a saccade is characterized by a high frequency burst, or *pulse*, which creates a large force for a short period of time (Robinson, 1964). The large force is required to overcome the forces of resistance that act on the eyeball, and, in addition, to obtain the large acceleration which is typical of saccades. After the completion of a saccade, the eye is held in its new position by a lower frequency discharge from the motoneurons, which is called the *step*, and which serves to counter the elastic forces, caused by the tissues in which the eyeball is suspended, that would otherwise drive the eye back to a position in which all the elastic forces would be in equilibrium. The magnitude of the step is thought to be calculated by the central nervous system through a mathematical integration of the pulse (Robinson, 1975). At the end of a saccade, the eye sometimes drifts, which is usually attributed to a mismatch between the pulse and the step (Weber and Daroff, 1972; Bahill et al., 1975a). These post-saccadic drifting movements are sometimes called *glissades*. If the step is too small relative to the pulse, a backward post-saccadic drift will result, whereas a step that is too large relative to the pulse will yield an onward post-saccadic drift. Adequate adaptation of saccades to various changes within the saccadic subsystem, should therefore entail adaptation of both the pulse and the step. Adaptation of the size of saccades to the weakening of an external eye-muscle has been demonstrated both in man and in monkey. In humans, the weakening was caused by disease, whereas in monkeys the external eye-muscles were weakened experimentally.

Kommerell et al. (1976) reported in detail on one of three patients who had developed a left-sided peripheral abducens paralysis. The affected eye had good visual acuity, whereas the acuity of the right eye was, by chance, very poor. Several weeks after the onset of the paralysis, the retinal image of the right eye was suppressed. The paretic eye with the better visual acuity then made leftward saccades (i.e., in the direction of the paretic lateral rectus muscle) that were orthometric, i.e., of the correct size, whereas the fellow eye made leftward saccades that were too large (hypermetric). Rightward saccades were orthometric in both eyes. After covering the left, paretic eye for three days, the saccades of the right, viewing eye had become orthometric in all directions, whereas the

covered, paretic eye then made saccades that were hypometric (too small) towards the left. In conclusion, the adaptative changes in saccade-size were reversible, and the changes that occurred in the viewing eye were paralleled by equal changes in the other eye.

In addition, the saccades of the right eye were, before patching, characterized by a very large rightward post-saccadic drift, notably for saccades made towards the left, suggesting a pulse-step mismatch. After patching of the left, paretic eye for three days, the post-saccadic drift of the right eye disappeared, with a concomitant increase in post-saccadic drift of the covered, left eye. In conclusion, the adaptations of post-saccadic drift were also reversible, and they were also paralleled by similar changes in the covered eye. All these findings support Hering's law in the sense that the adaptive changes in innervation were equal for each of the two eyes. As the adaptations of both the saccade-size and the post-saccadic drift were different for movements to the left than for movements to the right, Kommerell et al. (1976) concluded that such adaptations can be direction-specific. The velocities of the saccades made by the paretic eye in the direction of the palsy were always, i.e., before and after adaptation, lower than the velocities of the saccades of the same eye in the opposite direction, and also lower than the saccades of the unaffected eye in both directions. Similar results were reported by Abel et al. (1978), who elaborated on a patient with a sudden one-sided medial rectus palsy, secondary to a partial third nerve palsy, and also by Optican et al. (1985) who discussed four patients who all had one-sided lateral rectus palsies of various durations and of various degrees of severity.

In monkeys in which both horizontal recti muscles of one eye were weakened by tenectomy, the ensuing hypometric saccades of that eye became orthometric after three days of patching of the contralateral eye (Optican and Robinson, 1980). The post-saccadic drift that was prominent in the tenectomized eye shortly after the operation had by then disappeared. The patched eye, however, then made saccades that were hypermetric and were followed by a post-saccadic drift that was in a direction opposite to the direction previously observed in the tenectomized eye.

All the experiments described above indicate that symmetrical adaptations of saccades to weakened external eye muscles take place, and that these adaptations presumably encompass adaptations of both the step and the pulse. Optican and Robinson (1980)

demonstrated by partial ablation studies of the cerebellum in monkeys, that adaptations of either the pulse, or the step are independent and that they correspond with different parts of the cerebellum.

An important question in the understanding of the adaptation of saccades is which stimuli are adequate to induce these adaptations. A likely candidate is the visual information that enters the brain at the end of each saccade. Support for the likelihood of this candidate comes from the following experiments. It was recently demonstrated in monkeys (Vilis et al., 1985; Viirre et al., 1987), that after continuous patching of one eye for one week, the properties of the saccades of that eye changed, while the saccades of the viewing eye showed no changes. These findings suggest that visual information is essential to the calibration of each eye.

The importance of visual information at the end of a saccade to the calibration of the saccadic oculomotor subsystem is also supported by work of Miller et al. (1981) and Deubel et al. (1986). These workers had subjects make saccades by letting them track a visual target that jumped. Whenever a saccade was made, the target jumped again during the execution of the saccade. The second, intra-saccadic target jump was, consistently, either in the same direction as the saccade, thereby making the required gaze-shift larger than the initially planned gaze-shift, or it was consistently in a direction opposite to the saccade, thus decreasing the size of the required gaze-shift, relative to the planned saccade. After some experience, subjects responded to the first target-jump by making saccades which had magnitudes that were adapted to the second target-jump, i.e., they were larger after a period of onward intra-saccadic target displacements and they were smaller after a period of backward intra-saccadic target displacements. Deubel et al. (1986) found that these adaptations were direction-specific, which supported similar findings by Miller et al. (1981).

In addition, Deubel et al. (1986) observed that the adaptive changes that were induced by the intra-saccadic target-displacements at a specific saccade size, was also reflected in the magnitude of saccades of a different size in the same direction. From this, Deubel et al. concluded that adaptation in one direction takes place in a simple, *parametric* manner: one single gain element determines adaptive changes in saccade-sizes for all target eccentricities. This notion of a simple, direction-specific, gain element had been



suggested earlier by Miller et al. (1981). However, this notion is still under debate. In an experiment to be described below, Erkelens et al. (1989b) found that the adaptation of saccades appeared to be different for each target eccentricity, suggesting a point-by-point adaptation rather than an adaptation determined by one uniform parametric gain element. Despite this controversy, it is evident that visual feedback plays an important role in the adaptation of saccades. Visual feedback may not only affect saccadic size. Deubel (1987) demonstrated, both in man and in monkey, that an intra-saccadic target displacement could produce adaptive changes in saccadic direction.

In the experiments described by Miller et al. (1981), and also by Deubel et al. (1986), nothing was mentioned about the occurrence of post-saccadic drift. This may suggest that post-saccadic drift, if at all present, was not a very prominent characteristic of saccades adapting to a visual stimulus, which contrasts sharply with the adaptations of saccades adapting to weakened external eye-muscles, in which post-saccadic drift was very conspicuously present (Kommerell et al., 1976; Abel et al., 1978; Optican et al., 1985). This contrast suggests that the adaptations that occur either to the weakening of external eye-muscles or exclusively to a changed visual feedback, may occur at different levels, as was also suggested by Erkelens et al. (1989b). Visual feedback can also induce post-saccadic drift, without affecting saccade-size, as was demonstrated by Optican and Miles (1985), by artificially generating a slip of the retinal image in monkeys after every saccade that the monkeys made. The post-saccadic slip of the monkeys' eyes that was experimentally induced helped to stabilize the retinal image.

## ASYMMETRICAL ADAPTATION OF SACCADES

In the adaptation experiments described above, in which external eye muscles were weakened either by disease or experimentally, the adaptive changes were equally large for both eyes. Asymmetrical adaptation, i.e., adaptation that is different for each eye, was not required, because one of the two eyes was either patched or its retinal image was suppressed. In normal life, however, asymmetrical adaptation is presumably called for more frequently than symmetrical adaptation, because the changes in the oculomotor system caused by growth, ageing, disease or fatigue are very unlikely to affect each eye with exactly the same time course and to exactly the same degree. Therefore, I shall now

discuss the literature on asymmetrical adaptation in greater detail.

Snow et al. (1985) demonstrated asymmetrical adaptation of saccades in monkeys in which both horizontal recti muscles of only one eye were tenectomized. When both eyes remained unpatched for several weeks, the saccades of both eyes became orthometric and the post-saccadic drift that followed shortly after the tenectomy almost disappeared. In a similar experiment by Viirre et al. (1988), only one horizontal rectus muscle was surgically weakened in monkeys. After sufficient binocular experience, the normal yoking of saccades was virtually restored, which showed that asymmetrical adaptations to a parietic, external eye muscle could also be direction-specific.

Severing the tendons of one or more external eye-muscles brings about very dramatic changes to the oculomotor system. Because of their very sudden onset, combined with a high degree of severity, these changes presumably closely resemble an acute palsy of an eye muscle. However, such a tenectomy poorly resembles the presumably slight and gradual wear and tear that usually occurs within the oculomotor system throughout a lifetime. Therefore, considerably less invasive experimental designs are required to study adaptations to more natural, i.e., more moderate changes.

Henson and North (1980) showed that when a base-up prism was applied in front of one eye, the ensuing vertical phoria largely disappeared after just over three minutes of binocular visual experience, which reflects short-term adaptation to an asymmetrical change in visual information. These results were later confirmed by Henson and Dharamshi (1982). When a subject wears anisometric spectacles, he initially develops a phoria, whose magnitude depends on the eccentricity of the target that is binocularly fixated. Henson and Dharamshi (1982) found that the induced phoria largely disappeared after 2.5 hours of binocular visual experience. Similar results had been reported by Ellerbrock (1948) and Allen (1974). These results show something on end positions (perceptual, not recorded), but not on the dynamics of saccades.

Recently, Erkelens et al. (1989b) reported on a subject who had been wearing anisometric spectacles for many years. They observed that this subject made saccades that were of unequal size for the two eyes, thus representing asymmetrical adaptation to the unequal sizes of the images on each retina, caused by the anisometric

spectacles. Adaptations were almost complete for vertical saccades, but less complete for horizontal saccades. These asymmetrical adaptations differed in magnitude, depending on the eccentricity of the target, suggesting a point-to-point adaptation, instead of a simple adaptational change of a single gain parameter, as proposed by Deubel et al. (1986). Erkelens et al. (1989b) further demonstrated that asymmetrical adaptations of saccades were already present in two normal subjects after wearing anisometropic spectacles for about 8 hours. Short-communications of these and similar results had also been made by Collewijn et al. (1988c), Horner et al. (1988) and Levi et al. (1988).

Little is known, however, about the time course and the limits of these asymmetrical adaptations. In addition, there are, to my knowledge, no data available on the meridian-specificity of these adaptations. These problems will be dealt with in the following chapters.



## CHAPTER 3

### GENERAL METHODS

#### GEOMETRICAL PRINCIPLES

##### *Spherical coordinate systems*

Measuring eye movements requires a clear way of describing eye-positions. The most suitable way of describing eye-positions is in spherical coordinates. These are angles, expressed in degrees of arc (abbreviated to deg), which correspond with angular rotations of the eye in its socket. The centre of rotation of the eye is located, in normal human adults, approximately 13.5 mm posterior to the corneal vertex, which is the most anterior pole of the eye. As eye movements have three degrees of freedom, it is customary to describe each rotation of the eye in relation to a set of three axes, which intersect in the centre of rotation of the eye. Any rotation of the eye can therefore be geometrically broken down to its three axis-related rotational components.

Before going any further, I shall define the straight-ahead position of the eye as its primary position. The position of the head then has to be also straight-ahead and upright. With the head in this position, purely horizontal and purely vertical eye-positions are called secondary positions, whereas all other eye-positions are referred to as tertiary positions.

When the eye is in the primary position, the three axes of rotation are assumed to run horizontally in the frontoparallel plane, vertically and perpendicularly to the frontoparallel plane. They form the basis of three commonly used and slightly different coordinate systems, each of which describes the position of the eye in the head. The three systems have in common, that they all consider one of the three axes to be fixed in the head, while the other two axes are nested within the fixed axis. Therefore, in each coordinate system there exists a hierarchy of nested axes. The three systems differ

from each other in that they all have a different fixed axis, and, as a consequence, a different hierarchy of nested axes. I shall elaborate on two of these systems, because they are relevant to the present thesis. The third system will be discussed only in brief.

The first two coordinate systems to be discussed are frequently referred to as Fick's and Helmholtz's coordinate systems, named after their inventors in the nineteenth century (Von Helmholtz, 1867; for a treatise on both systems, see Carpenter, 1988).

In Fick's coordinate system it is the vertical axis that is fixed in the head, whereas in Helmholtz's coordinate system the horizontal axis is fixed in the head. This difference is best demonstrated by a model of the eye in its orbit, in which the eye is suspended in gimbals (Fig. 3.1).

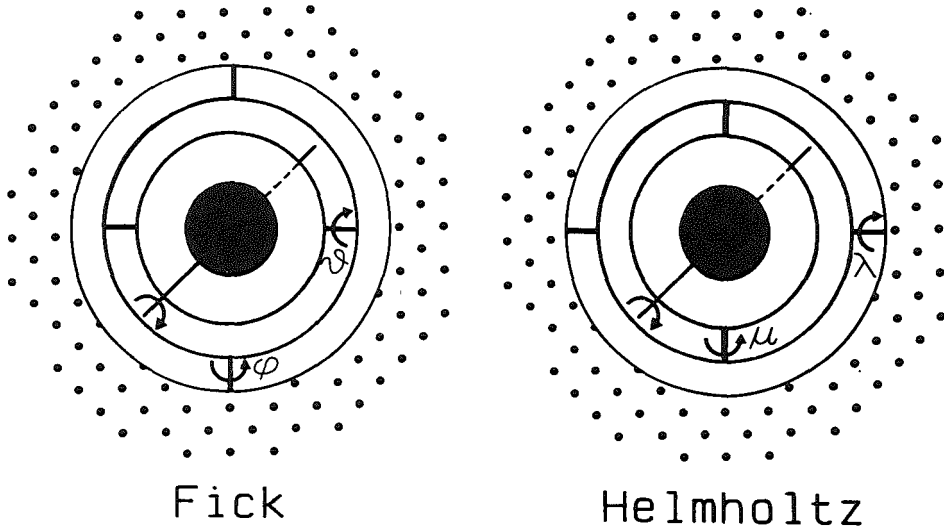


Fig. 3.1 Schema illustrating the hierarchy of nested axes in Fick's coordinate system (left panel) and in Helmholtz's coordinate system (right panel). In Fick's system, the vertical axis is fixed to the head, whereas in Helmholtz's system, it is the horizontal axis that is fixed to the head. For further details, see text.

In Fick's coordinate system, a horizontal rotation of the eye is described in terms of its *longitude* ( $\phi$ ) and a vertical rotation in terms of its *latitude* ( $\theta$ ). In Helmholtz's coordinate system, horizontal and vertical rotations are described in terms of *azimuth* ( $\mu$ ) and *elevation* ( $\lambda$ ), respectively. Rotations around the third axis, i.e., the visual axis,

relate to torsional eye-positions. These torsional eye-positions will not be considered here, because they are not related to the scope of this thesis.

When the eye moves from its primary position to a secondary position, only one of the three axes of rotation is involved in either coordinate system. In each system, the involved axis then has the same orientation in space. Therefore, for secondary positions, Fick's longitude equals Helmholtz's azimuth, and, in addition, Fick's latitude equals Helmholtz's elevation. This obviously applies also to primary eye-positions, in which the magnitudes of all four coordinates are, by definition, equal to 0 deg.

However, when the eye moves from its primary position to a tertiary position, both the horizontal and the vertical axes are involved in either system. Because of the different nesting of axes in the two systems, all four axes then become differently oriented in space. Therefore, for a tertiary position, Fick's longitude does not equal Helmholtz's azimuth, nor does Fick's latitude equal Helmholtz's elevation.

The relevance of the difference between these two systems is that Helmholtz's coordinate system is convenient for describing and comparing the positions of both eyes in one subject, whereas Fick's coordinate system does not offer such a convenient description. This difference will now be explained.

If a subject binocularly foveates a target in a tertiary position, the lines of sight will both lie in the same plane, which is called the plane of regard. In Helmholtz's coordinate system, each eye will have the same elevation, because both eyes share the same fixed, horizontal, axis. In Fick's coordinate system, however, both eyes will not have the same latitude, because the latitude depends on the longitude, which is different for each eye, because the centres of rotation of the two eyes do not coincide.

The angle subtended by the lines of sight is, by definition, the angle of vergence. I shall first discuss the angle of vertical vergence in either coordinate system. In Helmholtz's coordinate system, the angle of vertical vergence is given by the difference between the elevation of the left eye and the elevation of the right eye. In case of binocular foveation of a target in any position (primary, secondary or tertiary), the elevation of the two eyes will be identical. Therefore, the angle of vertical vergence will then be 0

deg. In contrast, if the angle of vertical vergence is similarly calculated in Fick's coordinate system by subtracting the latitude of the left eye from the latitude of the right eye, the vertical angle of vergence will not be equal to zero when a subject foveates a tertiary target with both eyes. This is due to the fact that the latitude depends on the longitude. Therefore, in Fick's coordinate system, the vertical angle of vergence is a less clear measure than the vertical angle of vergence in Helmholtz's coordinate system.

The angle of horizontal vergence can be simply calculated in Helmholtz's coordinate system by subtracting the azimuth of the left eye from the azimuth of the right eye. In Fick's coordinate system, however, the angle of horizontal vergence is again not very clear, because the longitude is expressed as the angle of rotation of the eye after projection onto a horizontal surface. As this projection changes as a function of the latitude, the angle of horizontal vergence is also an unclear measure.

In the third coordinate system to be discussed, the fixed axis runs perpendicularly to the frontoparallel plane. This system has three different names: 1) Listing's coordinate system, 2) the perimetric coordinate system, 3) the polar coordinate system. In this system, it is not the eye that rotates around the head-fixed axis. Instead, it is the axis which in the hierarchy of nesting comes second to the head-fixed axis, that rotates around the head-fixed axis. Therefore, rotations of the eye around its visual axis (i.e., torsional movements) cannot be described in Listing's coordinates. In other words, this coordinate system has only two degrees of freedom. This system has another drawback in that it cannot be easily used to describe and compare the positions of both eyes in one subject. This is due to the fact that, as in Fick's coordinate system, the fixed axes of both eyes do not coincide. In conclusion, Helmholtz's coordinate system is the most elegant system for describing eye positions of two fellow eyes.

#### *Interchanging the 3 coordinate systems*

In view of the considerations discussed above, I expressed the eye-positions in Helmholtz's coordinates. The positions of my target-stimuli, were, however, for practical reasons, controlled in a Fick's coordinate configuration. Therefore, I needed a convenient way to convert the coordinates of one system into the coordinates of the



other system, and vice versa. As no suitable solution could be found in the literature, I derived the appropriate equations, which will now be discussed in detail.

Figure 3.2 shows the angles in either coordinate system, which describe the position of point P in space in a fixed set of 3 orthogonal axes.

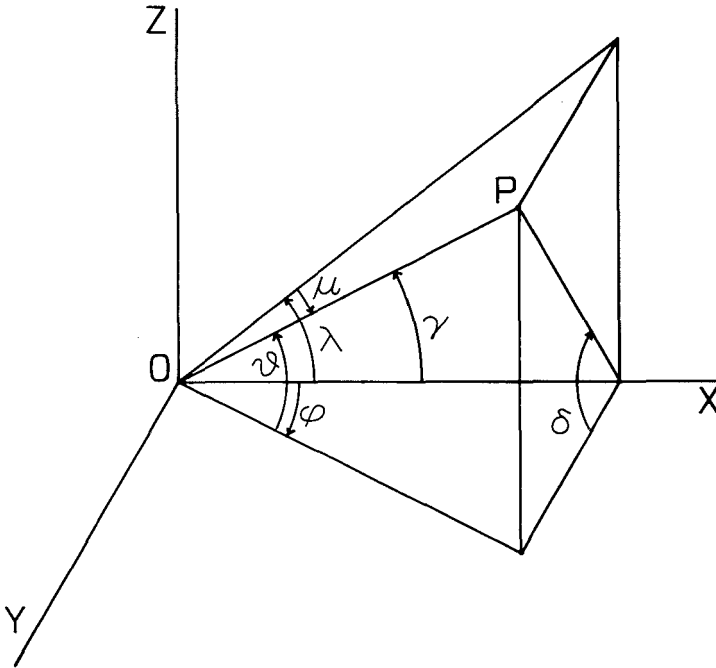


Fig. 3.2 Schema illustrating how the position of point P may be described in terms of Fick's, Helmholtz's or Listing's coordinates. For further details, see text.

$\lambda$  and  $\mu$  apply to Helmholtz's coordinate system, and  $\phi$  and  $\theta$  apply to Fick's coordinate system. The coordinates of point P are given by

(Helmholtz)

$$x = r.\cos\mu.\cos\lambda$$

$$y = r.\sin\mu$$

$$z = r.\cos\mu.\sin\lambda$$

(Fick)

$$x = r.\cos\theta.\cos\phi$$

$$y = r.\cos\theta.\sin\phi$$

$$z = r.\sin\theta$$

It can be shown by eliminating  $x$ ,  $y$ ,  $z$  and  $r$  that,

$$\lambda = \arctan(\tan \theta / \cos \phi) \quad (1)$$

$$\mu = \arcsin(\cos \theta . \sin \phi) \quad (2)$$

$$\phi = \arctan(\tan \mu / \cos \lambda) \quad (3)$$

$$\theta = \arcsin(\cos \mu . \sin \lambda) \quad (4)$$

Fick's coordinates can be transformed into Helmholtz's by applying (1) and (2), whereas (3) and (4) serve to transform Helmholtz's coordinates into Fick's.

Because eye movements are frequently described in Listing's coordinate system, I shall also present the appropriate equations to transform these coordinates into the coordinates of both Helmholtz's and Fick's coordinate systems, and vice versa. These equations were derived in a way similar to the equations (1) through (4). Listing's coordinates specify the position of the eye in terms of its *meridional angle* ( $\delta$ ) and its *eccentricity* ( $\gamma$ ), as indicated in Fig. 3.2.

To interchange the coordinates of Listing's and Helmholtz's coordinate systems, use

$$\lambda = \arctan(\tan \gamma . \sin \delta) \quad (5)$$

$$\mu = \arcsin(\cos \delta . \sin \gamma) \quad (6)$$

$$\delta = \arctan(\sin \lambda / \tan \mu) \quad (7)$$

$$\gamma = \arccos(\cos \mu . \cos \lambda) \quad (8)$$

To interchange the coordinates of Listing's and Fick's coordinate systems, use

$$\phi = \arctan(\tan \gamma . \cos \delta) \quad (9)$$

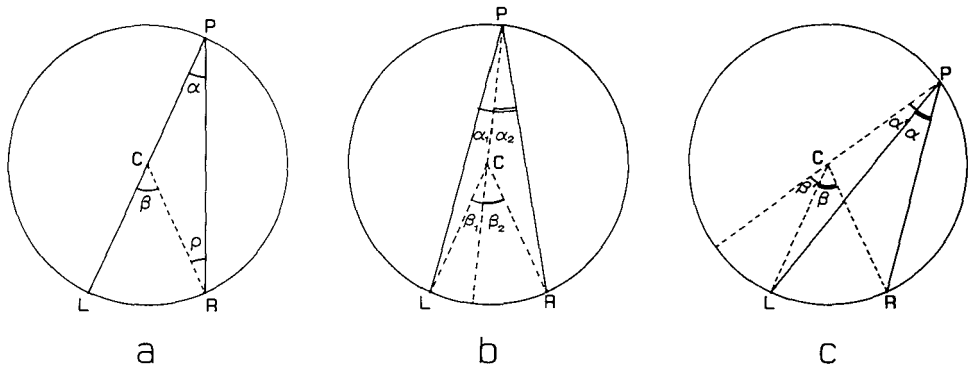
$$\theta = \arcsin(\sin \delta . \sin \gamma) \quad (10)$$

$$\delta = \arctan(\tan \theta / \sin \phi) \quad (11)$$

$$\gamma = \arccos(\cos \theta . \cos \phi) \quad (12)$$

*Stimulus presentation*

The main object of this thesis was to study differential adaptation of saccadic movements of the two eyes to anisometric spectacles. To avoid confusion with vergence eye-movements, I had to employ stimuli that did not require any vergence changes. To achieve this, a special stimulus screen was constructed. The geometrical principles of this screen will now be explained.



**Fig. 3.3** Illustration of the geometrical principles of an iso-vergence circle. Displayed are three different positions of point P located on a circle that passes through the centres of rotation of the two eyes (L and R). Irrespective of the position of P on this circle, the angle subtended by the centres of rotation of the eyes and point P is constant. For further details, see text.

When the centres of rotation of both eyes (L and R) are located on a circle, and point P is also located on that circle (Fig. 3.3), the angle  $\alpha$  subtended by the centres of rotation and point P is independent of the position of point P. This general property of points on a circle will now be clarified. Three different cases can be distinguished:

1) C lies on the line LP (Fig. 3.3a)

In this case

$$\beta = \alpha + \rho \tag{13}$$

In addition,

$$CP = CR \tag{14}$$

Therefore

$$\rho = \alpha \quad (15)$$

By substitution of (15) in (14), it follows that

$$\beta = 2\alpha \quad (16)$$

which equals

$$\alpha = \beta/2 \quad (17)$$

2) **C lies within  $\alpha$**  (Fig. 3.3b)

Then

$$\alpha_1 = \beta_1/2 \quad (\text{case 1}) \quad (18)$$

$$\alpha_2 = \beta_2/2 \quad (\text{case 1}) \quad (19)$$

By addition of (18) and (19), it follows that

$$\alpha_1 + \alpha_2 = (\beta_1 + \beta_2)/2 \quad (20)$$

Therefore, also in this case

$$\alpha = \beta/2$$

in which

$$\alpha = \alpha_1 + \alpha_2$$

and

$$\beta = \beta_1 + \beta_2$$

### 3) C lies outside $\alpha$ (Fig. 3.3c)

Then

$$\alpha + \alpha' = (\beta + \beta')/2 \quad (21)$$

$$\alpha' = \beta'/2 \quad (22)$$

By subtracting (22) from (21), one can show once more that

$$\alpha = \beta/2$$

If a subject foveates point P with both eyes,  $\alpha$  equals the angle of vergence. Therefore, the circle is an iso-vergence locus (Collewijn et al., 1988a). When this circle is rotated around the line between the centres of rotation of the two eyes, it describes a surface, which is called a torus. Such a toroid surface contains also vertical iso-vergence loci, if eye-positions are expressed in a Helmholtz coordinate system, because the plane of regard in Helmholtz's coordinate system coincides with the plane of the iso-vergence circle. For each angle of horizontal vergence, there exists a toroid surface that contains horizontal and vertical iso-vergence loci. At an infinite distance, the toroid surface is flat and runs parallel to the frontoparallel plane.

### THE STIMULUS SCREEN

I constructed a toroid screen of glassfiber and polyester. The diameter of the iso-vergence circle was 80 cm. The surface was painted white. In the properly placed subject, the screen covered almost the entire visual field. Subjects were positioned with reference to their corneal vertices, which were supposed to lie 13.5 mm anterior to the centres of rotation of their eyes. Head movements of the subjects were restricted by adjustable forehead- and chin-supports, with additional strapping of the head.

## TARGETS

The targets consisted of 2 bright-red He-Ne laser spots with a diameter of 5 min arc. For each target, a laser beam (LB) was first projected onto a front-surfaced mirror, which was mounted on the axle of a galvanometer (General Scanning) (see Fig. 3.4a). This axle was positioned horizontally, so that, by rotation of the axle the beam could be shifted in a vertical plane (mirror VP). Next, the beam was reflected to another front-surfaced mirror, which was mounted on a vertically positioned axle which, in turn, allowed for beam-shifts in a horizontal plane (mirror HP). This axle was positioned on the iso-vergence circle that was described above, to allow for a simple control of the horizontal target position (Fig. 3.4b). Finally, the beam was projected on the toroid screen.

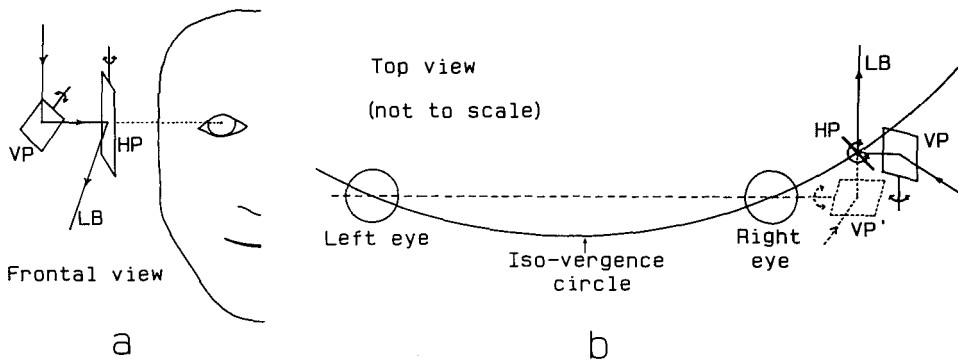


Fig. 3.4 Schema of the positioning of the scanning mirrors, the centres of rotation of the two eyes and the iso-vergence circle. a: frontal view. b: top view (not to scale). For further details, see text.

Note that the position in space (Fig. 3.4b) of the axis of rotation of mirror VP is, after reflection in mirror HP, virtually located on the line through the centers of rotation of both eyes. This configuration allowed for the simple control of beam shifts in the vertical plane. When mirror HP rotates about its fixed vertical axis, the position of the axis of rotation of the virtual mirror VP' changes in space. This spatial arrangement of axes, with a fixed vertical axis and a horizontal axis that is nested within the vertical axis, follows the hierarchy of axes in Fick's coordinate system. In principle, a Helmholtz configuration of axes of rotation would have been more convenient in the present

experimental set-up, if it had not been for the fact that the mirrors would then have to be located within the subject's head.

Two of such sets (of two mirrors each) were mounted in a fixed frame with one set on each side of the subject's head. The lateral positions of these two sets were taken into account in the equations that converted Fick's coordinates of the target-positions into Helmholtz's coordinates, and vice versa. All four scanners were driven independently by a computer. I therefore had two targets that were independently controlled and could be positioned anywhere on the screen. Position errors were less than 1%. Each scanner had a built-in transducer which supplied analog output signals representing the real angular positions of the mirrors. These signals were always recorded simultaneously with the signals that represented the eye-positions (see below). If necessary, one or both targets could be extinguished, either manually or by a computer-controlled shutter.

#### EYE MOVEMENT RECORDING-TECHNIQUE

Eye movements of both eyes were recorded simultaneously by magnetic sensor coils, introduced by Robinson (1963) and modified by Collewijn et al., (1975). This is the most accurate and precise recording technique with a large range that is currently available. Briefly, a copper coil, which is embedded in a specially molded soft-silicone ring, is pressed gently onto the eyeball, after local anaesthesia with a few drops of a topical agent. The silicone ring is shaped in such a way, that it adheres to the eyeball through suction. Slip of the coil is virtually absent (Collewijn et al., 1981). The properly placed ring lies over the corneo-conjunctival border, or limbus. A very thin copper wire leaves the coil, preferably at the inner canthus of the eye.

In Robinson's design, the subject is placed in an alternating current (a.c.) electromagnetic field, which induces an a.c. potential in the coil. This potential can be recorded from the wire that leaves the coil. As the amplitude of the potential depends on the magnetic flux through the coil, the a.c. potential is maximal when the plane of the coil is perpendicular to the direction of the field, and it is zero when the plane of the coil runs parallel to the direction of the field. Therefore, the a.c. potential relates

sinusoidally to the angular rotation of the coil, with reference to the direction of the field.

If two orthogonal magnetic fields are employed simultaneously, one being directed horizontally and the other vertically, the induced voltage is composed of the inductions by each magnetic field. If these magnetic fields are also 90 deg out of phase with each other (i.e., orthogonal in phase), it is possible to break the a.c. potential recorded from the sensor coil down to its horizontal and vertical components. It is therefore possible to measure vertical and horizontal eye movements simultaneously.

The frequency of my magnetic fields was 1245 Hz. Decomposition into two analog voltages, representing vertical and horizontal eye-positions, was done by dual-phase lock-in amplifiers (type: EG&G Princeton Applied Research, model 5210). Target-positions were recorded simultaneously with the eye-positions. All position signals were subsequently low-pass filtered at a cut-off frequency of 125 Hz, digitized with 12-bit precision and sampled at a rate of 238 Hz. All recordings were stored on disk or tape for off-line analysis. The overall noise level was less than 1.5 min arc.

## CALIBRATION PROCEDURES

The recording-equipment was pre-calibrated. Secondary corrections were carried out off-line by a special calibration computer programme to obtain a better accuracy of the calibration, to convert the signals to a Helmholtz coordinate system, and also to linearize the recordings. The principles of these secondary corrections will now be discussed.

As already mentioned, the amplitude of the a.c. potential induced in a sensor-coil relates sinusoidally to the angular rotation of the coil with respect to the direction of the magnetic field. After decomposition of this potential into its vertical and horizontal d.c. (direct current) components, the horizontal d.c. potential ( $V_x$ ) is, in Helmholtz's coordinate system, given by

$$V_x = k.\sin\mu + O_x \quad (23)$$



where  $k$  is a constant,  $\mu$  is the azimuth and  $O_x$  is an offset, introduced by various amplifiers and filters, through which the signal-current passes, before it is digitized and sampled.  $O_x$  was appropriately zeroed by adjusting the position of serial coils, which were mounted in the magnetic field, when sensor coils that were fitted on a calibration device, were put in the primary position. After this procedure, equation (23) becomes

$$V_x = k.\sin\mu \quad (24)$$

However,  $\mu$  is composed of 1) the azimuth of the eye ( $\mu_e$ ) with respect to an arbitrary zero-position, and 2) the position of the coil on the eye ( $\mu_c$ ) with respect to the direction of the magnetic field when  $\mu_e = 0$  deg. Therefore, equation (24) becomes

$$V_x = k.\sin(\mu_e + \mu_c) \quad (25)$$

Equation (25) is equivalent to

$$\mu_e = \arcsin(V_x/k) - \mu_c \quad (26)$$

If a subject foveates a target with a (horizontal) target-position  $\mu_t$ , then  $\mu_e$  equals  $\mu_t$ . Equation (25) then becomes

$$V_{xt} = k.\sin(\mu_t + \mu_c) \quad (27)$$

By measuring  $V_x$  while a target is foveated,  $\mu_c$  can be calculated, provided  $k$  is known. If  $k$  varies between coils, which may occasionally occur if a coil has an extra turn,  $k$  and  $\mu_c$  can be calculated from two steady fixations of two known targets ( $t1$  and  $t2$ ). For targets  $t1$  and  $t2$ , equation (27) becomes

$$V_{xt1} = k.\sin(\mu_{t1} + \mu_c) \quad (28)$$

and

$$V_{xt2} = k.\sin(\mu_{t2} + \mu_c) \quad (29)$$

It can be shown from equations (28) and (29) that,

$$\mu_c = \arctan[(\sin\mu_{t1} - p.\sin\mu_{t2}) / (p.\cos\mu_{t2} - \cos\mu_{t1})] \quad (30)$$

in which

$$p = V_{xt1}/V_{xt2} \quad (31)$$

In addition,

$$k = V_{xt} / \sin(\mu_t + \mu_c) \quad (32)$$

The vertical d.c. potential ( $V_y$ ) in Helmholtz's coordinate system is given by

$$V_y = c.\sin(\lambda_e + \lambda_c).\cos(\mu_e + \mu_c) + O_y \quad (33)$$

where  $c$  is a constant,  $\lambda_e$  and  $\lambda_c$  relate to the elevation of the eye, and the position of the coil on the eye, respectively.  $O_y$  represents an offset caused by the recording equipment, which in my experimental set-up was zeroed by serial coils, just as described above for  $O_x$ . Equation (33) is then equivalent to

$$\lambda_e = \arcsin[V_y / c.\sin(\lambda_e + \lambda_c).\cos(\mu_e + \mu_c)] - \mu_c \quad (34)$$

It can also be shown that

$$\lambda_c = \arctan[(\sin\lambda_{t1} - q.\sin\lambda_{t2}) / (q.\cos\lambda_{t2} - \cos\lambda_{t1})] \quad (35)$$

in which

$$q = V_{yt1}/V_{yt2} \quad (36)$$

In addition,

$$c = V_{xt} / [\sin(\lambda_t + \lambda_c).\cos(\mu_t + \mu_c)] \quad (37)$$

By applying equations (30) through (32), and equations (35) through (37), I computed  $\mu_c$ ,  $k$ ,  $\lambda_c$  and  $c$  for each eye, for every subject and for every experiment from steady fixations of targets with known positions. All raw recordings were then digitally adjusted to these values by application of equations (26) and (34), to obtain well calibrated, as well as linearized recordings expressed in Helmholtz's coordinates. The accuracy of the calibrations was better than 1%. Target-positions were also expressed in Helmholtz's coordinates. All recordings were subsequently submitted to specially designed computer programmes for their analysis. If any statistics were required, the data were submitted in a next step to an SPSS-X statistical programme.



## CHAPTER 4

# DIFFERENCES IN ACCURACY OF HUMAN SACCADES BETWEEN STATIONARY AND JUMPING TARGETS<sup>1</sup>

### INTRODUCTION

It is generally assumed that saccadic eye movements undershoot their target by approximately 10% of the angular distance between the new target and the previous target and are then followed by corrective saccades, which make up for the residual position error. These generalizations originate from work by Becker and Fuchs (1969) and, for smaller saccades, from work by Henson (1979). Recently Collewijn et al. (1988a) found that their subjects made saccades that were far more accurate: they undershot their targets by about 0.5 deg, irrespective of the target amplitude, which was varied over a very wide range (1.25 - 80 deg). Saccadic undershoot, therefore, ranged between a minimum of less than 1% up to a maximum of only 5%.

One of the possible explanations for this unexpectedly good accuracy was that Collewijn et al. (1988a) ran their experiments in conditions that were far more natural than customary laboratory conditions. They used stationary, continuously visible targets within a structured visual context (a normally lit laboratory). Traditionally, however, experiments on saccades are conducted with targets that jump, flash, appear or disappear suddenly on a dark or homogeneous background (e.g. Westheimer, 1954; Becker and Fuchs, 1969; Prablanc and Jeannerod, 1975; Hallett and Lightstone, 1976; Becker and Jürgens, 1979; Deubel et al., 1982; Van Gisbergen et al., 1987). Such discontinuous stimulus presentations are useful in the study of the timing of saccades, such as saccadic latency. It is less clear, however, that such stimuli are best suited for studying saccadic accuracy. Zingale and Kowler (1987) pointed out recently that experiments in which such

---

<sup>1</sup> A slightly modified version of this chapter has been accepted for publication in *Vision Research*.

discontinuous stimuli are employed are designed as if saccades were reflex-like movements, instead of voluntary gaze shifts.

In the present study I compared the accuracy of saccades made between stationary targets to the accuracy of saccades elicited by a jumping target. To my knowledge, such a direct comparative study has not been done before. I found that saccadic undershoot was two to five times smaller with stationary targets. In parallel with this increased accuracy, the number of corrective saccades was significantly reduced. In addition, the total time required to foveate the target was approximately 60 ms shorter with stationary targets than with a jumping target. My results confirm and take into account the expectation drift prior to an expected target displacement, reported by Kowler and Steinman (1979a,b, 1981) and Kowler et al., (1984).

To assess the effects of some other commonly employed, though unnatural, experimental conditions on saccadic accuracy, I extended the scope of the present study further by studying two other variables: monocular versus binocular viewing and a dark versus an illuminated background. With monocular viewing, saccadic accuracy of the viewing eye turned out to be as good as with binocular viewing. A dark background, however, led to an increase in the time required to foveate the target by about 50 ms. The present results have been preliminarily reported in abstract form (Lemij et al., 1988).

## METHODS

### *Subjects*

Complete data were obtained from eleven subjects. Their ages ranged between 24 and 52 years (mean age: 31 years). None of them had any history of ocular or oculomotor pathology. Refractive anomalies existed in seven subjects, all of whom were myopic. Five of these myopes wore contact-lenses and the other two had spectacles, which they wore only on rare occasions, and not during the experiments. Vision was at least 5/5 in each eye of the subjects who never wore spectacles. The two myopic subjects who occasionally wore spectacles had lower acuities at 5 metres (without corrective lenses) but could clearly see the experimental targets at the used target distance of approximately 80 cm. The refractive power of their spectacles was less than -2.5 diopters. All subjects had

good binocular vision, as ascertained by stereopsis test-charts (type: TNO test for stereoscopic vision). Routine cover-examination revealed no marked phorias in any of the subjects. Eight of the subjects were completely naive as to the purpose of the experiment.

### *Recording technique*

The movements of the right eye were recorded by means of magnetic sensor coils as developed by Collewijn et al. (1975), combined with Robinson's (1963) phase-locked amplitude-detection technique. My field frequency was 1245 Hz and the overall bandwidth was estimated at 150 Hz. All recordings were low-pass filtered at a cut-off frequency of 250 Hz, digitized with 12-bit precision at a sampling rate of 400 Hz and stored on disk or tape for off-line analysis. The recording equipment and search coils were pre-calibrated. Recordings of steady fixations of at least three known target positions allowed for slight additional off-line corrections of offsets and gains, if necessary. The required adjustments never exceeded 3 deg (offset) and 1% (gain).

### *Stimuli*

Targets consisted of one or two bright red laser spots with a diameter of 5 min arc, projected onto the white iso-vergence screen that was described in detail in Chapter 3. In the dark-background condition the laboratory lights were turned off; subjects could then see nothing but the targets. With the lights turned on, the screen was dimly lit, and vague shadows of laboratory equipment were cast on it. Head movements were restricted by means of a chin and a forehead support, to which the head was strapped.

### *Experimental procedures*

The experiment consisted, for each subject, of two similar sessions, run immediately after each other. Every session was made up of twenty-four trials of 10 s each. These trials were run in a randomised order, which was different for every subject. Subjects were allowed to relax for approximately 30 s between successive trials. Half of the trials was carried out in the dark (i.e. with only the targets visible). In the remaining trials the screen was lit. In either state of illumination (dark or light) the subjects viewed with one

eye in half of the cases, and with both eyes in the other half of the cases. To obtain monocular viewing, the subjects covered their left eye with a patch, mounted on a stick. The patch did not limit the visual field of the viewing, right eye. In half of each of the described conditions, subjects had to fixate and follow a single target, which jumped horizontally at a constant rate of fifty steps per minute between two fixed positions, distributed symmetrically about the midline. These steps had a size of 10, 20 or 40 deg. In the remaining half of each of the conditions, subjects had to alternate their gaze between two stationary, continuously present targets at a similar pace, marked by the sound of a metronome. The angular separations between these two targets were identical to those in the jumping target condition. Subjects were instructed to carry out all gaze shifts as accurately as possible. No time-pressure was imposed to avoid any possible trade-off between accuracy and speed. Subjects were requested to avoid blinking during trials, because blinking causes eye movements (Collewijn et al., 1985). Each trial began with the presentation of the new experimental condition. Subjects were then allowed some practice and when they felt ready, they started the actual data collection themselves by pushing a button. This approach was chosen because I was interested in steady-state performance and not in transient behaviour possibly associated with the first responses to a changed stimulus. Most subjects allowed themselves approximately 4 s of practice before starting.

### *Data analysis*

All recordings were analysed by computer programmes. Each primary saccade was detected by a velocity criterion of 15 deg/s, combined with an amplitude criterion set at 30% of the target amplitude. The primary saccade was assumed to have ended, when its velocity fell below 15 deg/s. Velocities were calculated simply by dividing the difference in eye position between two successive samples by their time interval. No additional filtering, smoothing or window-techniques were used. For each primary saccade three parameters were computed: amplitude, duration and peak-velocity. In addition, true position error at the end of each primary saccade was determined by subtracting absolute eye position from absolute target position. Secondary, corrective saccades were scored if they met the following criteria: 1) they had to be preceded by a primary saccade; 2) they had to exceed the same velocity criterion of 15 deg/s; 3) they had to be larger than 0.25 deg, because microsaccades associated with fixation (see e.g. Haddad



and Steinman, 1973) should not be scored as secondary saccades . Care was taken that neither the small return movements associated with dynamic overshoot (see Bahill et al., 1975b), nor subsequent primary saccades were scored as secondary saccades. If a primary saccade was followed by one or more secondary saccades, I determined the latency of the first secondary saccade, i.e., the time between the end of the primary saccade and the beginning of the first secondary saccade. After every secondary saccade, position error was calculated. The number of secondary saccades which brought the eye within 0.25 deg of the target was defined as the necessary number of secondary saccades. In addition, I calculated the time-lapse between the end of the primary saccade and the end of the last necessary secondary saccade. This time-lapse was defined as the post-saccadic foveation time. The saccadic amplitudes, the saccadic durations, the position errors at the end of each primary saccade and the numbers of secondary saccades were transformed into their logarithmic values to meet the requirements of normal distributions and homogeneous variances for further statistical analysis. For similar reasons, I extracted the square-roots of the post-saccadic foveation times and the latencies of the secondary saccades. Peak velocities did not need to be transformed. All data were submitted to a multivariate analysis of variance. As it turned out that no significant results were observed between the two successive sessions, their data were pooled.

## RESULTS

### *Magnitude of primary saccades*

Saccades elicited by a jumping target were metrically different from those made between two stationary targets. Figure 4.1 shows some typical saccades of one subject (GV) in either condition. An important phenomenon associated with saccades which are elicited by a jumping target is, that the eyes frequently begin to drift towards the next target-position before the target has actually jumped. This pre-saccadic drift was discovered and extensively described as expectation-drift by Kowler and Steinman (1979a,b , 1981) and Kowler et al. (1984). In my conditions, the magnitude of this pre-saccadic drift was on the order of 0.4 deg for all three target amplitudes. Occasionally, however, presaccadic drift was as large as 1.5 deg. In Fig. 4.1 this drift is most clearly visible in the lower panels, because of the larger scale. In agreement with

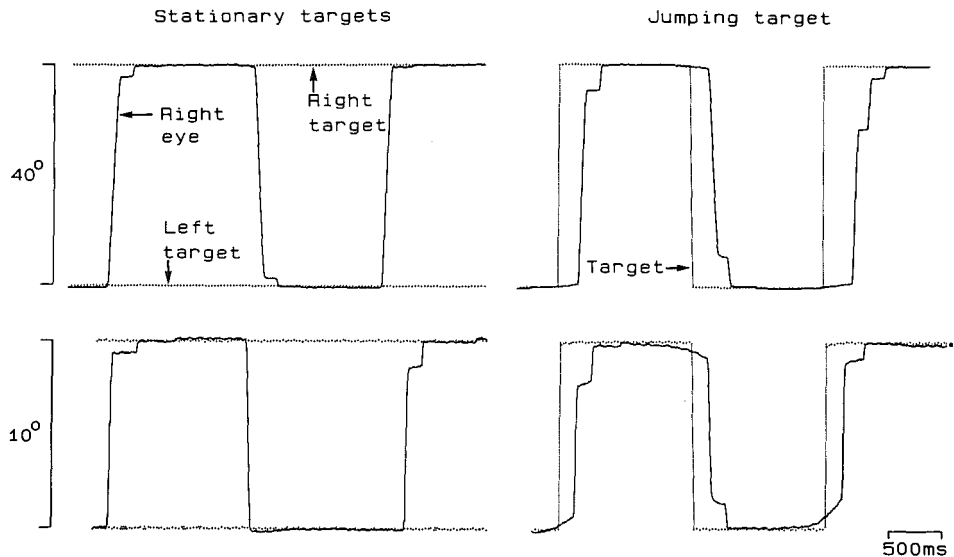


Fig. 4.1 Typical recordings of saccadic eye movements either between stationary or jumping targets, for two target amplitudes.

Kowler and Steinman (1979a,b , 1981), expectation drift was not observed with stationary targets. This, by now well-known, phenomenon has an important bearing upon the definition of saccadic accuracy.

Saccadic accuracy relates to eye position error at the end of the primary saccade. If a saccade begins exactly from the first target position, its accuracy can simply be determined by subtracting the saccadic amplitude from the target amplitude. However, if a saccade does not have its onset exactly on the first target, such as occurs with expectation drift, the size of the saccade is no longer a direct measure of its accuracy. For that reason I calculated position error directly.

Position errors at the end of the primary saccades were about two to five times smaller with stationary targets than with a jumping target. This difference was especially marked at smaller target amplitudes. For the 10 deg target amplitude the error was, on average, 0.3 deg with stationary targets and 1.5 deg with the jumping target. For a target amplitude of 40 deg mean values were 2.3 and 4.3 deg, respectively. These differences were all statistically highly significant:  $F_{1,10} = 53.2$ ;  $P < 0.0005$ . Figure 4.2 presents the

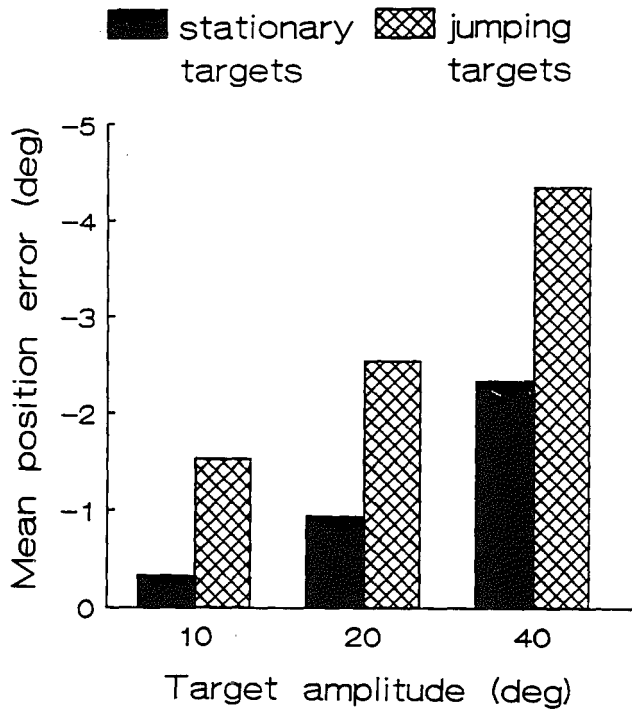
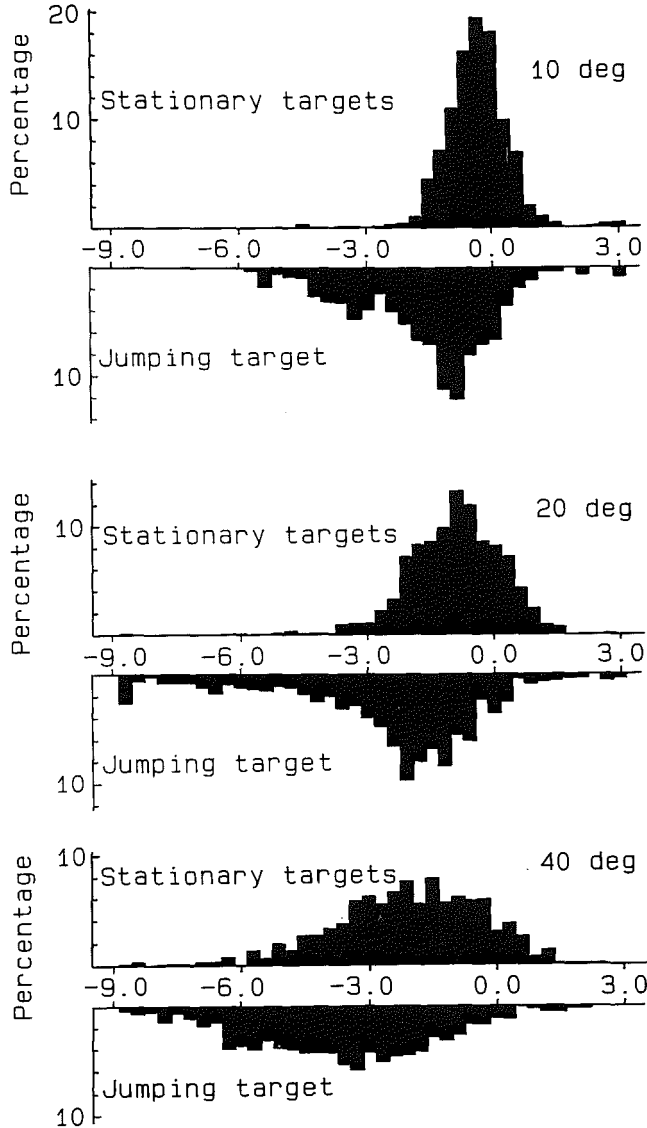


Fig. 4.2 Mean values of position errors (deg) for all subjects and all three target amplitudes in both the stationary targets and the jumping target condition.

mean values for all subjects and for all three target amplitudes in both conditions. The negative sign of the mean position errors represents saccadic undershoot. Note that the difference in accuracy would have appeared even larger, if position errors had merely been inferred from the saccadic amplitudes, because the expectation drift associated with jumping targets decreases the amplitude of a saccade. To give an example: the mean saccadic amplitude at the smallest target amplitude (10 deg) was 9.6 deg with stationary targets and 7.8 deg with a jumping target. The difference between these two is 1.8 deg, which is 50% larger than the actual mean difference in position error, which equalled 1.2 deg (1.5 versus 0.3 deg). The discrepancy of 0.6 deg is due to expectation drift.

The distributions of the position errors in the conditions with either stationary targets or a jumping target are presented for the three different target amplitudes in the histograms of Fig. 4.3. Negative position errors relate to saccadic undershoot and positive



**Fig. 4.3** Distributions of position errors (binwidth 0.3 deg) for all three target amplitudes in both the stationary targets and jumping target condition. Negative position errors indicate saccadic undershoot and positive position errors saccadic overshoot.

errors to saccadic overshoot. All data are included. Figure 4.3 demonstrates a number of important features of saccadic accuracy in the various conditions: 1) The distributions of position errors of saccades made between stationary targets were almost symmetrical,

notably at the 10 and 20 deg target amplitudes, whereas the distributions relating to the jumping target condition were significantly skewed in the direction of undershoot; 2) The modal values of the position errors of the saccades elicited by a jumping target were shifted towards the side of saccadic undershoot, when compared to the findings for the stationary target condition. The combined effects of 1) and 2) contribute to the mean increase in saccadic undershoot of saccades made to a jumping target compared to those between stationary targets (Fig. 4.2); 3) The variability of the position error increased at larger target amplitudes; 4) The distributions shifted towards the left at larger target amplitudes, corresponding to a gradual increase in saccadic undershoot at larger target amplitudes. At the smallest target amplitude (10 deg), the distribution associated with the stationary targets was almost symmetrical around a position error of 0.0 deg.

The difference in position error between the two target conditions was not a transient phenomenon. It occurred throughout the whole period of a trial and did not diminish. Even in the second session, which was run immediately after the first session, the difference in position error was equally large ( $F_{1,10} = 2.72$ ;  $P > 0.10$ ).

The peak velocities of primary saccades were lower by about 20 deg/s in the jumping target condition than in the stationary target condition ( $F_{1,10} = 6.55$ ;  $P < 0.05$ ). Likewise, durations were shortened by about 5 ms ( $F_{1,10} = 36.65$ ;  $P < 0.0005$ ). I determined whether these effects were merely epiphenomena of the smaller saccadic amplitudes associated with a jumping target or represented a different category of saccades, suggesting a possibly different underlying oculomotor programme. For each of the three target amplitudes, I matched approximately two-hundred saccades which had been made between stationary targets with a similar number of saccades of comparable size which had been elicited by a jumping target. Peak velocities and durations of these saccades were submitted to an analysis of variance. Neither peak velocities, nor saccadic durations proved to be significantly different from each other (peak velocity:  $F_{1,10} = 0.29$ ;  $P > 0.5$ . duration:  $F_{1,10} = 0.03$ ;  $P > 0.8$ ). Therefore, the lower peak velocities and shorter durations of saccades elicited by a jumping target are, most likely, fully accounted for by the smaller saccadic sizes.

*Secondary saccades: magnitude*

Primary saccades which do not end on target are followed by secondary, usually called corrective saccades. Visual inspection of recordings suggests that the large majority of the secondary saccades does indeed reduce the position error. To quantitatively assess whether all secondary saccades are indeed corrective, I counted the total number of secondary saccades and the number of secondary saccades that were necessary to foveate the target within 0.25 deg. This criterion of 0.25 deg was the same one as used to detect secondary saccades. I found that about 95% of all secondary saccades were indeed corrective. Only occasionally did secondary saccades increase the position error. The rest of my statistics on secondary saccades is based on all secondary saccades in my study and not only on those secondary saccades which were truly corrective.

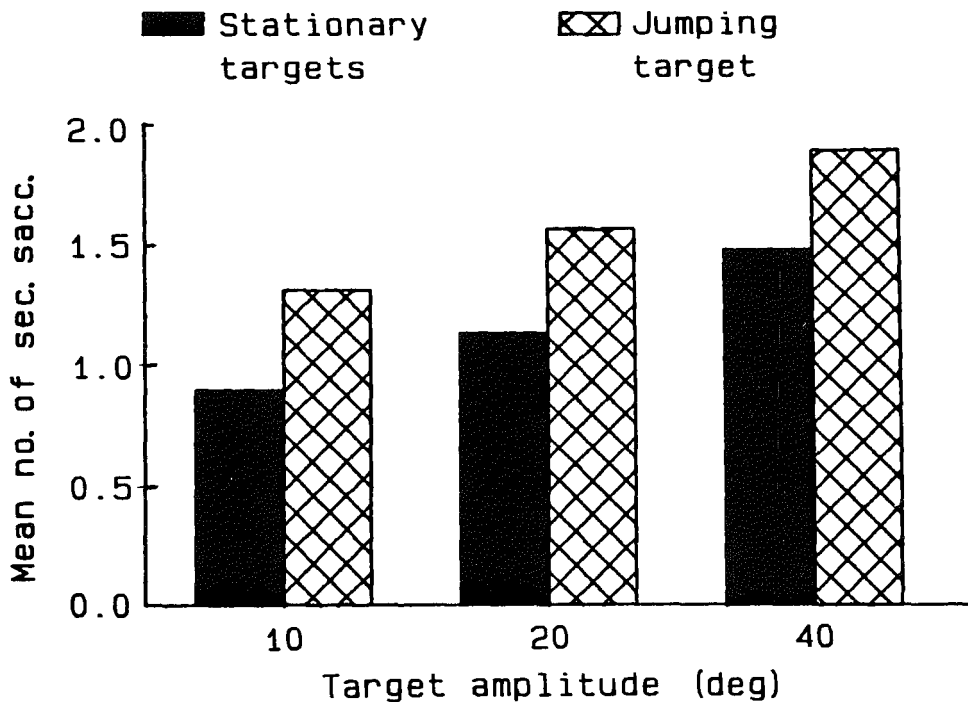
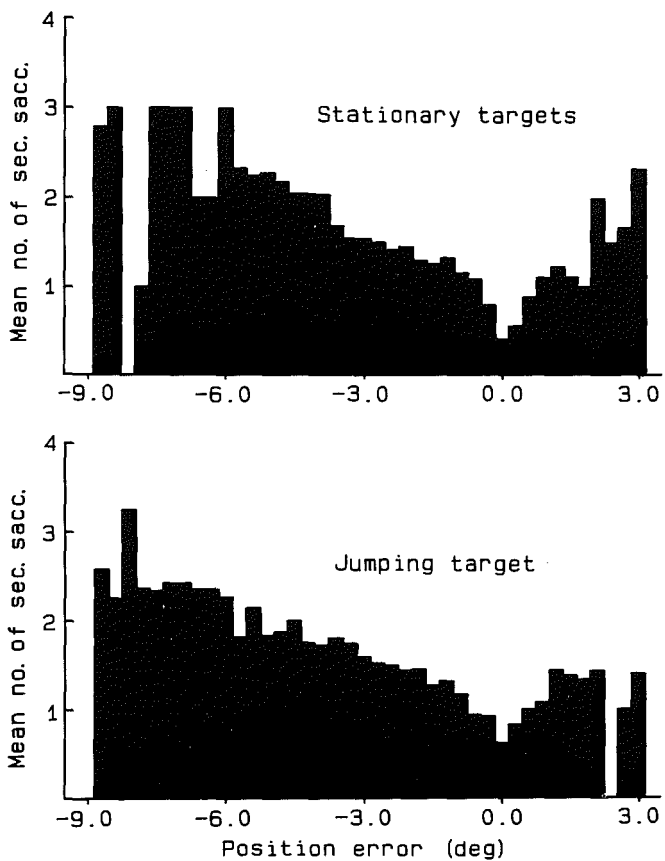


Fig. 4.4 Mean number of secondary saccades following each primary saccade for all three target amplitudes in either target condition (jumping target or stationary targets).

Saccades elicited by a jumping target were followed by a substantially larger number of secondary saccades than saccades made between stationary targets. Mean values are presented in Fig. 4.4. At the smallest target amplitude in this study (10 deg), the mean number of secondary saccades was 0.89 with stationary targets, and 1.31 with a jumping target. This increase by approximately 0.4 in the jumping target condition was observed at all three target amplitudes. It corresponded to a statistically significant rise in the number of secondary saccades by about 25 to 50% ( $F_{1,10} = 43.2$ ;  $P < 0.0005$ ). In addition, the number of secondary saccades went up at higher target amplitudes, irrespective of whether the targets jumped or remained stationary ( $F_{2,20} = 84.3$ ;  $P < 0.0005$ ). At the largest target amplitude (40 deg) the average numbers of secondary saccades were 1.89 in the stationary target condition and 1.48 in the jumping target condition. These figures also emphasize that the number of secondary saccades in this study was frequently larger than one.

As a next step, I tested whether the number of secondary saccades was correlated with the magnitude of the position error after each primary saccade. A positive correlation would explain the increased frequency of secondary saccades both at larger target amplitudes and with a jumping target. I therefore determined the mean number of secondary saccades made for all the various magnitudes of position error at the end of every primary saccade in my study. I distinguished between saccades made to a jumping target and saccades made between stationary targets. The results are presented in the histograms of Fig. 4.5, which demonstrate that the mean number of secondary saccades increased at larger position errors, irrespective of whether the position error consisted of saccadic undershoot or overshoot. This increase occurred both with stationary targets and with a jumping target. A position error at the end of a primary saccade of 0.6 deg (either undershoot or overshoot) was followed, on average, by about 1 secondary saccade. The mean number of secondary saccades was twice as large after an undershoot of 4.5 deg, and increased to 2.6 after an undershoot of 8.7 deg. Note that even with a position error of 0.0 deg (range: -0.1 to +0.1 deg), secondary saccades were made (mean number: 0.46).

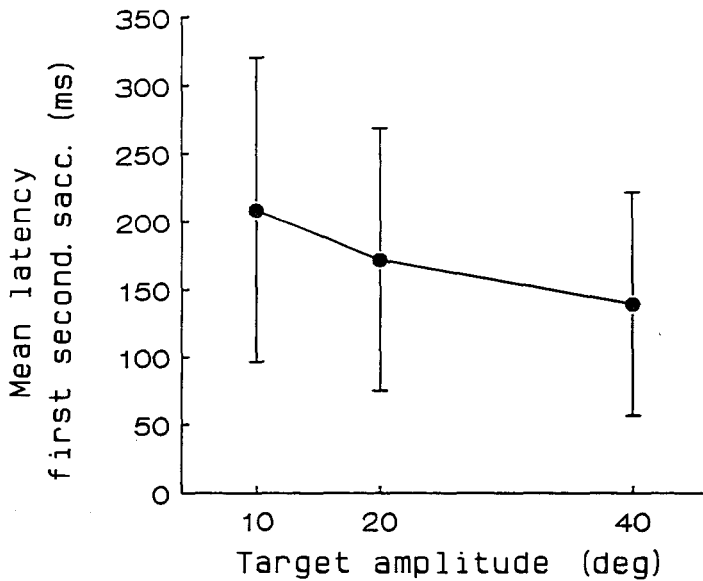


**Fig. 4.5** Mean numbers of secondary saccades following each primary saccade as a function of the magnitude of the post-saccadic position error (binwidth 0.3 deg). Negative position errors indicate saccadic undershoot; positive position errors indicate saccadic overshoot.



*Secondary saccades: timing*

The mean latencies of the first secondary saccades, calculated from the moment at which the primary saccade ended (velocity < 15 deg/s), are presented in Fig. 4.6, for the three different target amplitudes. They depended only on target amplitude and not on any of the other stimulus variables of my experimental conditions. The latencies went down at larger target amplitudes, with a high level of statistical significance:  $F_{2,20} = 73.2$ ;  $P < 0.0005$ . At the smallest target amplitude in the present study (10 deg) the mean latency of the first secondary saccade was 208 ms. At the 20 deg target amplitude it averaged 171 ms and at the largest target amplitude (40 deg) the mean value equalled 138 ms.



**Fig. 4.6** Mean latencies of secondary saccades for all subjects and all three target amplitudes. Secondary saccades made in either target-condition (jumping target or stationary targets) are pooled, because no significant differences were observed.

I wanted to know whether there was a negative correlation between the latency of the first secondary saccade and the magnitude of the position error at the end of each primary saccade, because such a correlation would contribute to the observed decrease of mean latencies at larger target amplitudes. A scatterplot of all saccades which

undershot their target is presented in Fig. 4.7. The dense cluster in this scatterplot indeed suggests a very slight, negative correlation between the latency of the first secondary saccade and the position error at the end of the primary saccade. It is, however, evident from the widespread scatter in the rest of Fig. 4.7 that this correlation is, on the whole, very weak. In conclusion, the latency of the first secondary saccade is indeed negatively correlated with the target amplitude, and virtually not with the magnitude of the error after the primary saccade.

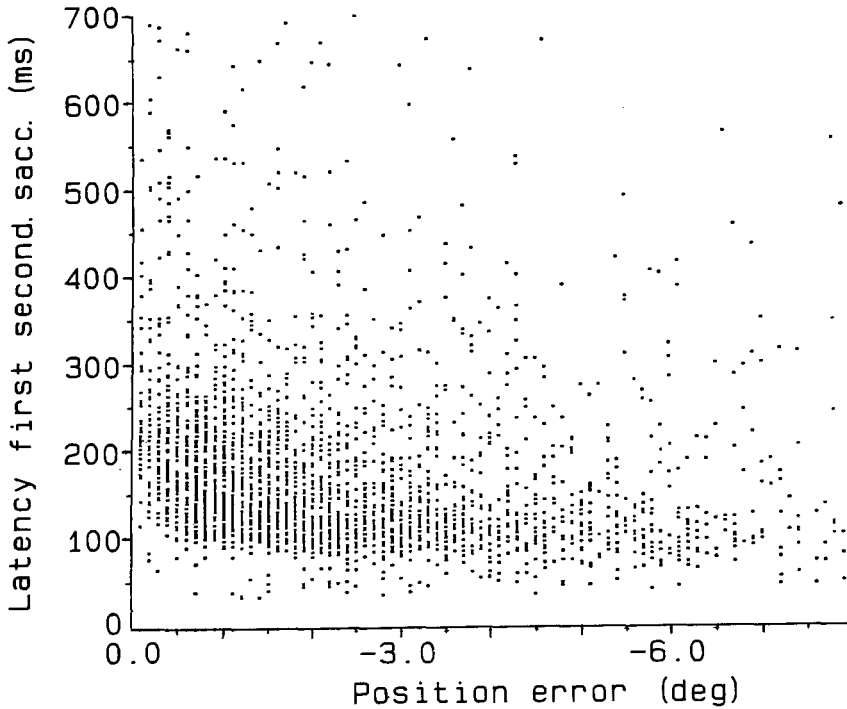
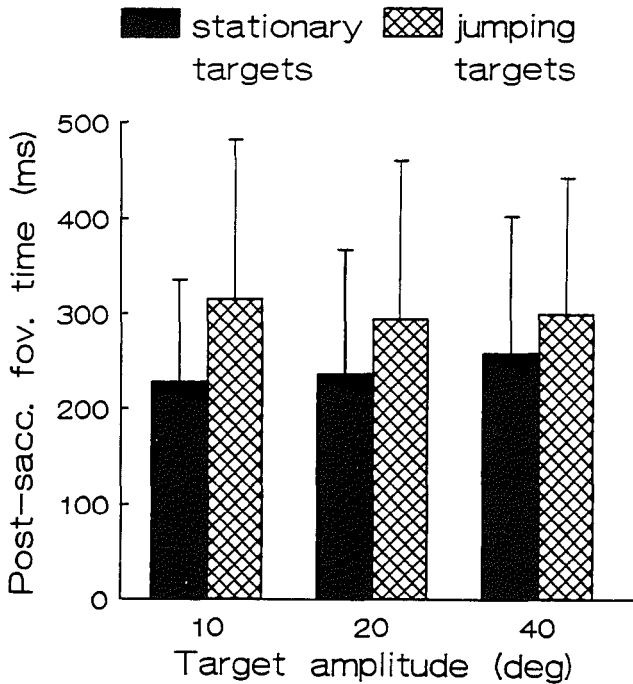


Fig. 4.7 Scatterplot of latencies of first secondary saccades as a function of position error (deg undershoot). Latencies are truncated at 700 ms.

I also determined how much time elapsed between the end of the primary saccade and the moment at which position error fell below 0.25 deg immediately after a secondary saccade. With jumping targets this post-saccadic foveation time was considerably longer than with stationary targets. This applied to all three target amplitudes. Mean values are presented in Fig. 4.8. At the smallest target amplitude in this study (10 deg), mean post-saccadic foveation time was 228 ms with stationary targets and 315 ms with a

jumping target. At the 40 deg target amplitude mean post-saccadic foveation times were 258 and 299 ms, respectively. The reduction in post-saccadic foveation time of saccades made between stationary targets, when compared to saccades elicited by a jumping target, were statistically significant:  $F_{1,10} = 16.4$ ;  $P < 0.005$ . Although the latencies of the first secondary saccades proved to be dependent on the target amplitude, as already mentioned, this was not the case with the post-saccadic foveation times ( $F_{2,20} = 2.15$ ;  $P > 0.10$ ).



**Fig. 4.8** Mean values of post-saccadic foveation times (+ SD) for all subjects and all three target amplitudes, in either target condition.

Finally, I determined whether the post-saccadic foveation time was correlated with the magnitude of the position error at the end of each primary saccade. This correlation turned out to be absent.

### *A dark versus a dimly lit background*

There was only one robust effect related to background conditions. When the background was dark, post-saccadic foveation time was on average 50 ms longer than when the screen was illuminated, irrespective of the target amplitude ( $F_{1,10} = 44.6$ ;  $P < 0.0005$ ). The mean value with a dark background was 279 ms and 229 ms with a lit screen. The latencies of the first secondary saccades were not affected by either state of background illumination.

Differences in the magnitude of the position error in the two conditions of background illumination were idiosyncratic. Statistical analysis of the position errors, pooled for all subjects, proved that there was no significant overall effect of background illumination on position error at the end of primary saccades ( $F_{1,10} = 4.58$ ;  $P > 0.05$ ). Similarly, I observed very slight and statistically non-significant ( $P > 0.05$ ) differences in saccadic durations, and also in the number of secondary saccades, between the dark-background condition and the condition when the background was illuminated.

### *Monocular versus binocular viewing*

The overall effect of the viewing condition (either binocular or only the right eye viewing) on post-saccadic position error of the right eye was statistically not significant:  $F_{1,10} = 3.28$ ;  $P > 0.05$ . Saccadic peak velocities and saccadic durations of the right eye were also similar for either binocular viewing or right eye viewing (peak velocity:  $F_{1,10} = 1.81$ ;  $P > 0.2$ , saccadic duration:  $F_{1,10} = 0.13$ ;  $P > 0.7$ ). All parameters related to the movements of the right eye following a primary saccade (number of secondary saccades, latency of the first secondary saccade and the post-saccadic foveation time) were also unaffected by the covering of the left eye.

## DISCUSSION

### *Effects of target condition on position error*

The present experiment demonstrates clearly that jumping targets elicit saccades that undershoot their target considerably more than saccades made between stationary

targets. To my knowledge, this difference has not been systematically studied and described before. Lauritis and Robinson (1986) did mention in passing, however, that saccades made between stationary targets had a comparatively good accuracy and display a relatively small variability of position errors, in comparison with the values in the literature, which are considered to be typical of saccades elicited by sudden visual changes, such as jumping targets. Weber and Daroff (1971, 1972), however, who employed stationary targets in a range comparable to mine, did not find such a good saccadic accuracy as I did. This discrepancy may be largely attributed to the fact that all their computations were based only on position errors that were larger than 1 deg, which contrasts with the resolution of 0.1 deg that I applied.

Why are saccades that are made between stationary targets far more accurate than saccades elicited by a jumping target? A possible explanation for this difference is that, while fixating one target in the stationary target condition, a subject can already see the other target with the peripheral part of his retina. This allows the oculomotor system to compute the oncoming saccade well in advance, to the benefit of its accuracy. The accuracy of a saccade therefore appears to be dependent upon the amount of time that the target is presented. This agrees well with the finding by Prablanc and Jeannerod (1975), that saccadic accuracy improved as the time that a peripheral target was presented (within a range of 20 to 200 ms) became longer. These findings might be related to the observations made by Sparks et al. (1987), who found, in monkeys, that the motor commands which generate saccades evolve gradually, which suggests that shortening of the time in which the computation of a saccade is made, could possibly affect its execution. However, it is unclear whether shortening of the time in which visual information is acquired results in a shortening of the time in which the motor commands are calculated.

Since most saccades we make in every-day life are aimed at objects that we have already seen with our peripheral retina well before saccadic onset, my results suggest that real-life saccades are much more accurate than has been suggested by previous studies. This is also supported by Collewyn et al. (1988a), who ran their experiments in conditions that were even more natural than mine (i.e., with a normally lit laboratory as visual background) and found a saccadic accuracy that was on the whole better than in the present study.

The importance of the background is also stressed by my finding that the post-saccadic foveation time was significantly longer when the background was dark, than when it was lit and contained some structure (blurred shadows). This suggests that a lit and vaguely structured background, which has more resemblance with every-day life conditions than a completely dark background, improves the overall efficacy of the saccadic system, by reducing the time that is required to foveate a target. I did not observe, however, that the magnitudes of the post-saccadic position errors were smaller with a lit background, when compared to the dark-background condition. It remains to be seen whether a real-life background, such as employed by Collewijn et al. (1988a), significantly improves saccadic accuracy, both in terms of post-saccadic position error and post-saccadic foveation time, when compared to a background which is less rich in visual structure, such as in my lit-background condition. The present study did not serve to distinguish between the effects of the structure of the background, acting as a frame of reference for localizing stimuli, versus the possible effects of the level of illumination per se.

The increased undershoot in the jumping target condition cannot be described as a single shift of the distributions of the position errors in the direction of undershoot. It results from the combination of a modal increase in saccadic undershoot, as well as an increased skewing of the distributions (see Fig. 4.3). I have no solid explanation for the modal increase in saccadic undershoot, although it appears to be an increase in the normal, yet not convincingly explained, tendency of the saccadic subsystem to generate saccades that undershoot their target.

To explain the increased variability of the position errors with jumping targets in comparison to the stationary targets condition, the following tentative hypothesis may be put forward. As the time to acquire visual information of the exact position of the newly selected target is relatively short with a jumping target, when compared to the stationary target condition, this time may have reached a critically low value. The visual information acquired during that short period of time may therefore be just enough to generate a saccade, but on the other hand be so scarce, that the programming of that saccade becomes more sensitive to noise, which results in a larger scatter of the position errors.

The scatter of position errors of saccades has recently gained interest. Van Opstal and

Van Gisbergen (1989) proposed a model which attributes the scatter of saccadic endpoints to noise occurring at the level of the motor map of the superior colliculus, whereas Deubel (1987) assumes that noise affects saccadic endpoint-variability at a more downstream level. My results suggest that the time in which visual information is acquired should be included in their models since saccades elicited by a jumping target show considerably more variability in their position errors than saccades made between stationary targets. I do not know whether the time to acquire visual information also has any effect on the scatter in the direction of saccades, which is an important part of their models. Note, however, that their models are based on experiments in which jumping targets were employed. It remains to be seen whether those models also hold in more natural conditions. My present results indeed support the possibility that the model of Van Opstal and Van Gisbergen (1989) will hold in more natural conditions, because, even with stationary targets, the variability of position errors increases at larger target amplitudes, as predicted by their model.

#### *Expectation drift and the determination of position error*

Kowler and Steinman (1979a,b , 1981) and Kowler et al. (1984) demonstrated that subjects make smooth eye movements in the direction of an expected target displacement, which they called expectation drift. In their first paper on this topic (Kowler and Steinman, 1979a), they used a target that stepped periodically back and forth, a condition which closely resembles the jumping target condition in my experiment. One difference is that their target steps were much smaller (10 to 426 min arc) than the steps in my experiment (10 to 40 deg). They quantified their results in the form of mean velocities of the expectation drift. They did not explicitly discuss the magnitudes of the expectation drift but, judging from their figures, this was on the order of 15 to 25 min arc. In the present experiments, expectation drift was of comparable magnitude, although occasionally it was as large as 1.5 deg. Such large magnitudes of the expectation drift in my experiments confirm the observation by Kowler and Steinman (1979a) that the velocity of this drift increased at larger target steps, at least in the range they studied. This study confirms that expectation drift occurs only as a result of an expected target motion, and not prior to an expected saccade, because I observed no expectation drift in my stationary target condition.

The importance of expectation drift with respect to saccadic accuracy, expressed as post-saccadic position error, is that the magnitude of a saccade becomes a poor measure of its accuracy if the saccade is preceded by expectation drift. It is often unclear, however, whether in previous investigations any attention was paid to this phenomenon. The determination of position error at the end of a primary saccade in those studies therefore remains somewhat ambiguous, because it is unclear how it was estimated. An indirect way to estimate the error is to measure the size of the primary saccade and to subtract it from the target amplitude, which is usually well known in an experimental setting. An obvious advantage of this way of measuring saccadic accuracy is, that it is unaffected by any fluctuations in offset, such as occur frequently in electro-oculography (EOG), due to drift. The more direct way of determining position error at the end of a primary saccade is to record the true eye position at saccadic offset and to assess its angular distance to the true position of the target. Obviously, this can be done only when a recording method with a stable baseline, such as the magnetic sensor coil, is used. These two ways of determining position error at the end of a primary saccade are identical only if the primary saccade begins exactly on the initial target. Since this does not appear to be the case in quite a number of saccades, the second method of determining position error at the end of a primary saccade is the only correct one. I demonstrated that this distinction becomes especially significant when differences in saccadic accuracy are studied between saccades made to a jumping target and saccades made between stationary targets, because expectation drift occurs only in the jumping target condition.

### *Secondary saccades*

It was found that the number of secondary saccades went up both at larger target amplitudes and with jumping targets. These findings agree very well with my additional observation that the mean number of secondary saccades which follow a primary saccade increases with larger position errors. This relationship between the number of secondary saccades and the position error at the end of a primary saccade, either relating to saccadic overshoot or saccadic undershoot, has to my knowledge not been described before. However, somewhat comparable findings were reported by Weber and Daroff (1971, 1972) and by Henson (1979), who studied the incidence of corrective saccades, which is, by definition, not equal to the number of corrective saccades: the incidence of



corrective saccades indicates how many primary saccades are followed by one or more corrective saccades, whereas the number of secondary saccades indicates how many secondary saccades follow, on average, each primary saccade.

#### *Latencies of secondary saccades*

The present results indicate that the latencies of the first secondary saccades go down at larger target amplitudes. There is not a very close relationship between the latency of the first secondary saccade and the position error at saccadic offset. This contrasts with a rule that Becker (1976) proposed, based on his own previous work (Becker, 1972) and also based on work of Prablanc and Jeannerod (1975). According to Becker's rule the latency of the first corrective saccade following a post-saccadic position error smaller than 2 to 3 deg equals the normal reaction time for a single target-step, i.e., approximately 200 ms. For position errors larger than 2 to 3 deg, but smaller than about 10 deg, a correction saccade would result with a latency of 120 to 140 ms. Saccades with larger position errors than 10 deg, would be followed by secondary saccades with even shorter latencies than 120 ms. In contrast, my findings demonstrate that the latencies of the first secondary saccades, associated with both small and large position errors, range from a minimum of about 100 ms to a maximum well over one reaction time (200 ms). Therefore, my results indicate that the distinction between latencies of secondary saccades and latencies of primary saccades is by no means clear. Although this distinction is not clear, this does not necessarily imply that the latencies of secondary saccades reflect similar neural processes as the latencies of primary saccades to a single target-step do, because the latency of a secondary saccade probably reflects a normal physiological process, as opposed to the latency of a primary saccade to a single target-step, which reflects a response to a very artificial experimental condition.

#### *Post-saccadic foveation time*

Since the most important objective of a saccade and any successive secondary saccades is to foveate a target, or at least bring the target very close to the fovea, where acuity is high, I considered it of interest to measure the post-saccadic foveation time. This has, to my knowledge, not been measured before. I demonstrated that this post-saccadic foveation time was independent of the target amplitude. It was, however, significantly

longer with jumping targets than with stationary targets. This difference is certainly not due to a possible relationship between position error, which is larger with jumping targets than with stationary targets, and post-saccadic foveation time.

The present results suggest that the visual information on the exact position of the selected target, which is acquired in the stationary target condition while fixating the initial target, is not only used in the programming of the primary saccades, but also in the programming of subsequent, secondary saccades. These results may also suggest that the entire process of foveation, consisting of a primary saccade and possibly one or more secondary saccades, is planned as a whole. Zingale and Kowler (1986) showed that a sequence of saccades is planned as a whole, rather than as multiple, independent saccades. Their observation applied to primary saccades. My results suggest that the planning of a sequence, rather than independent saccadic eye movements, also applies to the sequence of a primary saccade, followed by secondary saccades. The latter is of course not very surprising because primary saccades, which according to Zingale and Kowler are planned in a sequence, are interleaved by secondary saccades, which makes it highly probable that they are also planned in the entire programme.

The latencies of the first secondary saccades were not affected by the target condition, which contrasts with the post-saccadic foveation time. Also, the post-saccadic foveation time was strongly affected by the background illumination, suggesting that the background plays an important part in the programming of saccades, whereas the latencies of the first secondary saccades were not affected by background illumination. These observations suggest that post-saccadic foveation time may prove more useful in the study of the programming of saccades than the latency of the first secondary saccades, which has traditionally received more interest.

In conclusion, the present study demonstrates that the accuracy of human saccades is significantly affected both by the temporo-spatial arrangements of the targets and by their background.

## CHAPTER 5

### CONJUGACY OF SACCADES

#### INTRODUCTION

The main objective of this thesis is to study asymmetrical adaptations of human saccades to anisometropic spectacles. Because asymmetrical adaptations are, by definition, different for either eye, these adaptations are best studied by comparing the saccades of each of the two eyes with each other. Asymmetrical adaptations are then represented by changes in the degree of yoking (conjugacy) of the two eyes. Moreover, hard-programmed asymmetrical adaptations are best demonstrated when one eye is covered, because, in that case, any possible change in the degree of yoking of saccades can only be explained by a more permanent asymmetrical adaptation, and not by the direct effects of asymmetrical visual input associated with binocular viewing through anisometropic spectacles.

However, the degree of yoking per se can only be used as a clear and reliable measure of asymmetrical adaptation, if the conjugacy of saccades before adaptation is perfect. Although a perfect conjugacy of saccades is traditionally assumed (Hering's law of equal innervation), very few accurate data actually exist on the yoking of saccades.

Collewijn et al. (1988a,b), using highly accurate recording techniques, reported that both horizontal and vertical saccades are not perfectly conjugate in binocular viewing. During the execution of horizontal saccades the eyes diverged transiently. Abducting saccades were consistently larger by about 0.3 deg than the concomitant adducting saccades of the fellow eye. In addition, abducting saccades reached higher peak-velocities and had shorter durations than the contralateral, adducting eye. The conjugacy of vertical saccades was, however, better than the conjugacy of horizontal saccades. Furthermore, shortly after patching one eye, horizontal saccades of the covered eye were generally

slightly smaller than the horizontal saccades of the viewing eye (Collewijn et al., 1988a), although no quantitative data on these size-reductions were given. In addition, it is unclear if the yoking of vertical saccades is also affected by the covering of one eye. The present chapter will focus on the conjugacy of horizontal and vertical saccades in humans, both during binocular and monocular viewing, before adaptation. I shall confine this study to saccadic start- and endpoints, rather than go into the dynamical aspects of the yoking of saccades. In addition, I shall examine the conjugacy of both eyes shortly after completion of a saccade, for reasons explained below.

Adaptive changes of saccades to the weakening of one or more external eye muscles are partly characterized by conspicuous changes in post-saccadic drift, which are thought to be due to adaptations of both the pulse and the step of the motor commands to the external eye muscles (Kommerell et al., 1976; Abel et al., 1978; Optican et al., 1985; Snow et al., 1985; for a review, see Chapter 2). Therefore, asymmetrical adaptations to anisometric spectacles may possibly affect post-saccadic drift differently for each of the two eyes, which will be reflected by changes in the degree of yoking. Very small changes in post-saccadic drift secondary to the wearing of anisometric spectacles were reported by Erkelens et al. (1989b). Again, for a clear assessment of such changes, it is important to study the degree of yoking during post-saccadic drift prior to adaptation.

To date, accurate data on normal post-saccadic drift in humans, and, more specifically, on its degree of yoking, are scarce and incomplete. The few available data were obtained from rather limited numbers of subjects. Kapoula et al. (1986) studied post-saccadic drift in both eyes associated with horizontal saccades during binocular viewing. Post-saccadic drift of the adducting eye was almost always in the onward direction (i.e., in the same direction as the saccade), whereas the drift of the abducting, fellow eye could be either backward or onward. The drift of the adducting eye had a higher velocity than the drift of the contralateral, abducting eye. Drift-velocities increased with target amplitude and could become as high as about 6 deg/s. These results were later confirmed by Collewijn et al. (1988a), who, in addition, studied post-saccadic drift with horizontal saccades during monocular viewing. Post-saccadic drift during monocular viewing was the same as during binocular viewing. In a second paper, Collewijn et al. (1988b) reported on post-saccadic drift associated with vertical saccades. The second study was confined to binocular viewing. Vertical saccades, both upward and downward,

were followed by conjugate, upward drift, with velocities up to about 3 deg/s. After upward saccades, drift-velocities increased with saccade-size. In contrast, velocities of post-saccadic drift after downward saccades decreased with saccade-size. There is, to my knowledge, no literature on post-saccadic drift associated with vertical saccades during monocular viewing.

In conclusion, because accurate data on the conjugacy of saccades, and also on the conjugacy of post-saccadic drift are scarce and incomplete, I shall, in the present chapter, systematically study saccade-size, as well as post-saccadic drift in both eyes, for horizontal and vertical saccades, both during binocular and monocular viewing.

## METHODS

This section describes the experimental procedures that were also adopted in the following chapters. Any departures from these standard procedures will be duly mentioned.

### *Subjects*

Nine healthy subjects participated in this experiment. None of them had any history of ocular or oculomotor pathology. They were between 25 and 44 years old. Refractive anomalies existed in four subjects, all of whom were myopic. All of these myopes normally wore corrective contact lenses, which they also wore during the experiment. Visual acuity was at least 5/5 in all emmetropic subjects, and also in the myopes wearing their normal contact lenses. Because the presence of binocular vision was considered important for the outcome of the experiment, stereopsis was assessed with a standard test (type: TNO test for stereoscopic vision). All subjects performed normally on this test (thresholds: 120 sec arc or better).

### *Stimuli*

Subjects were seated facing the toroid, iso-vergence screen that was described in detail in Chapter 3. They were positioned in such a way that the centres of rotation of the two

eyes, assumed to be located 13.5 mm posterior to the corneal vertices, were located on the iso-vergence circle which, by rotation around the interocular baseline, described the surface of the torus. Movements of the head were limited by means of a forehead- and chin-support, with additional straps. Two bright red He-Ne laser spots (diameter approximately 5 min arc), that were position-controlled by mirror-galvanometers, were simultaneously projected onto the screen. These two spots served as stationary targets. I used stationary targets because they yield more accurate saccades than those which are elicited by a, more conventional, jumping target (Lemij and Collewyn, 1989c; Chapter 4). The laboratory lights were left on, thus dimly illuminating the rest of the toroid screen, as was also described in Chapter 4.

### *Experimental procedures*

Subjects were requested to make accurate gaze shifts between the two stationary targets at a comfortable pace of 45/minute, marked by a ticking sound from a loudspeaker. I did not exert any time-pressure, in order to avoid a possible compromise between accuracy and speed. Subjects were also asked to refrain from blinking during actual recording, because blinking produces eye-movements (Collewyn et al., 1985). Each experiment consisted of twenty-four trials for every subject. One half of these trials involved horizontal saccades, whereas the other half of the trials involved saccades in the vertical meridian. For each meridian, saccades were made between targets that were 5, 10, 20 or 30 deg apart, positioned symmetrically around the straight-ahead position. Viewing was either binocular, or monocular with either eye, in equal numbers of trials. The order of the trials was randomized for every subject. To obtain monocular viewing, subjects covered one eye with a patch that was attached to a handle. This device did not limit the visual field of the viewing, fellow eye. Trials lasted 12 s each. Therefore, eight to ten saccades were recorded in each trial. Before each trial began, the targets were presented in their new positions and subjects were allowed to practice for a few seconds. When the subjects felt ready for the trial, they started the actual recording themselves by pushing a start button. This experimental procedure was chosen, because I was only interested in steady-state performance, and not in any possible effects of a suddenly changing visual scene.

When all twenty-four saccade-trials had been completed, one target was extinguished, and the other target made a smooth, circular movement, with a diameter of 30 deg and a velocity of 11 deg/s. Subjects were instructed to follow the target as accurately as possible for 12 s, beginning at the push of the start button. Viewing was either binocular, or monocular with either eye. These recordings served as control data for asymmetrical adaptations of smooth-pursuit eye movements to the wearing of anisometropic spectacles, as will be described in detail in the following chapters, along with the asymmetrical adaptations of saccades.

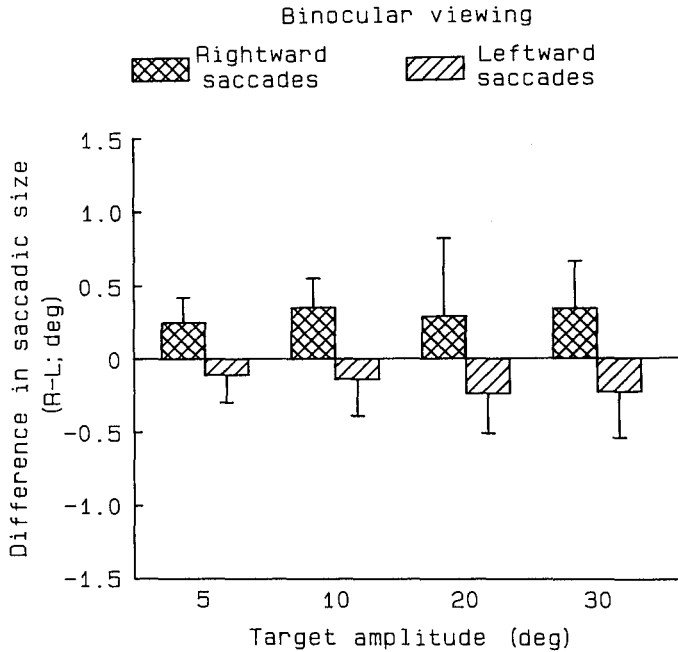
#### *Data collection and analysis*

Eye movements of both eyes were recorded simultaneously by means of magnetic sensor coils (Collewijn et al., 1975). I adopted the magnetic-field configuration originally described by Robinson (1963). The recordings were digitized and stored on disk or tape for off-line analysis. The overall bandwidth was about 125 Hz (for further details on the recording equipment, see Chapter 2). The equipment was pre-calibrated. Recordings of steady monocular fixations of targets with known positions allowed for off-line, digital fine-tuning of the calibrations as well as linearization of the recordings, and also transformation of the linearized recordings into Helmholtz's coordinates. The principles of all these transformations were described in detail in Chapter 2.

The recordings were thereafter analyzed by computer-programmes. Saccades were identified by standard criteria. A saccade was considered to have occurred if: 1) the velocity of the eye movements exceeded 15 deg/s, and 2) the movement was also larger than an amplitude criterion, which was set at 2 deg for the smallest target separation (5 deg) and 4 deg for all other target separations (10 through 30 deg). When eye velocity fell below 15 deg/s, the saccade was considered to have ended (saccadic offset). Each saccade was characterized by its magnitude and direction. In addition, the mean velocity of the post-saccadic drift was calculated as the mean velocity of the eye movement over a period of 68 ms, beginning 25 ms after saccadic offset. These criteria were adopted, first of all to disregard eye movements associated with dynamic overshoot (Bahill et al., 1975b; Kapoula et al., 1986), and secondly to avoid contamination of the computations by secondary saccades. As was demonstrated in Chapter 4, virtually all secondary saccades occur well over 90 ms after saccadic offset.

*Statistical analysis*

All data were submitted to a computer programme (SPSS-X) for statistical analysis. To balance the data, those saccades that had been made in excess of a total of eight (i.e., four in each direction) in every trial were disregarded. The remaining data were used to calculate mean values. The same data were also submitted to a multivariate analysis of variance (MANOVA). To meet the requirements of normal distributions and homogeneous variances, the amplitudes of the saccades, as well as the post-saccadic drift-velocities were transformed logarithmically.



**Fig. 5.1** Mean size-differences (+ SD) between horizontal saccades of the two eyes during binocular viewing, calculated as the size of a saccade of the right eye minus the size of a fellow saccade of the left eye, at all four target amplitudes.



## RESULTS

### *Horizontal saccades - binocular viewing*

Horizontal saccades were normally not perfectly conjugate, which confirms similar findings by Collewijn et al. (1988a). The abducting eye made saccades that were about 0.3 deg larger than the adducting, fellow eye ( $F_{1,8} = 26.6$ ;  $P < 0.001$ ), irrespective of the target amplitude. Mean size-differences between horizontal saccades of the 2 eyes in binocular viewing are presented in Fig. 5.1. As a consequence of the size-difference between abducting and adducting saccades, the angle of convergence was about 0.3 deg smaller at saccadic offset than at the beginning of the saccade. In some subjects, this size-difference between concomitant saccades of the two eyes was consistently larger for saccades towards one side, most frequently towards the right, than for saccades towards the opposite side.

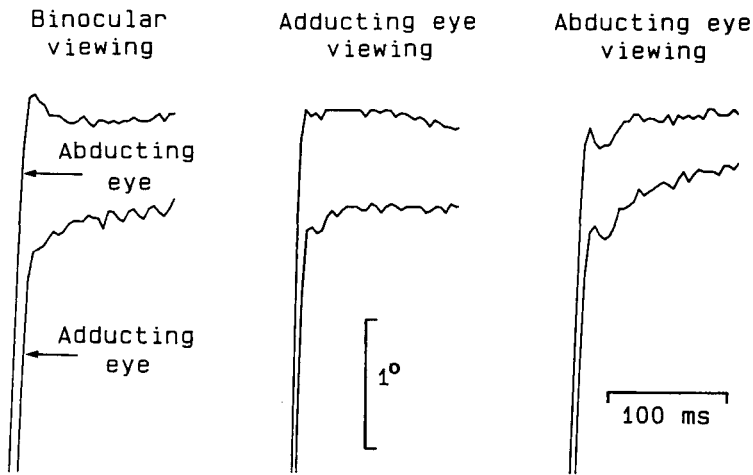
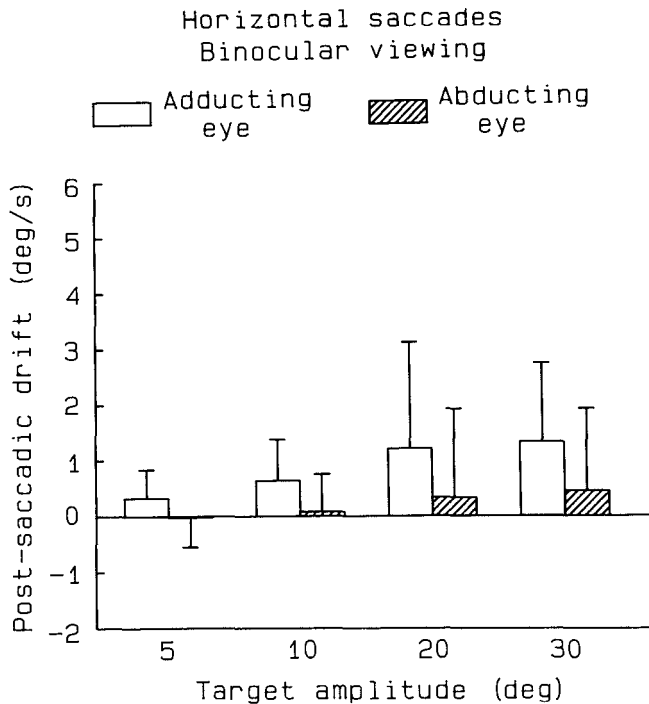


Fig. 5.2 Typical recordings of the two eyes, showing post-saccadic drift of horizontal saccades in each viewing condition. The target amplitude in all three conditions was 10 deg. For clarity, the recordings of the adducting and the abducting eye have been plotted slightly apart.

After saccadic offset, the eyes normally drifted slightly (Fig. 5.2). The direction of the drift that followed an adducting saccade was typically onward (i.e., in the same direction as the saccade), whereas the fellow, abducting eye drifted either backward or onward. At larger target amplitudes, however, post-saccadic drift of the eye that made an

abducting saccade was also most frequently in the onward direction. Figure 5.3 presents mean drift-velocities associated with adducting, as well as abducting saccades for all four target amplitudes. The eye that made an adducting saccade drifted at higher velocity than its fellow, abducting eye ( $F_{1,8} = 15,2$ ;  $P < 0.005$ , Figs 5.2, 5.3). The velocity of the post-saccadic drift of both adducting and abducting saccades increased with the target amplitude ( $F_{3,24} = 18.0$ ;  $P < 0.0005$ ). At the smallest target amplitude (5 deg) post-saccadic drift associated with an adducting saccade had a mean velocity of about 0.3 deg/s and at the largest target amplitude (30 deg) the mean velocity equalled about 1.3 deg/s. The mean velocity of the drift following abducting saccades ranged between less than about 0.1 deg/s at a target amplitude of 5 deg up to about 0.5 deg/s at a target amplitude of 30 deg. Because the post-saccadic drift-velocity of adducting saccades went up more steeply with the target amplitude than the drift-velocity following abducting saccades, the



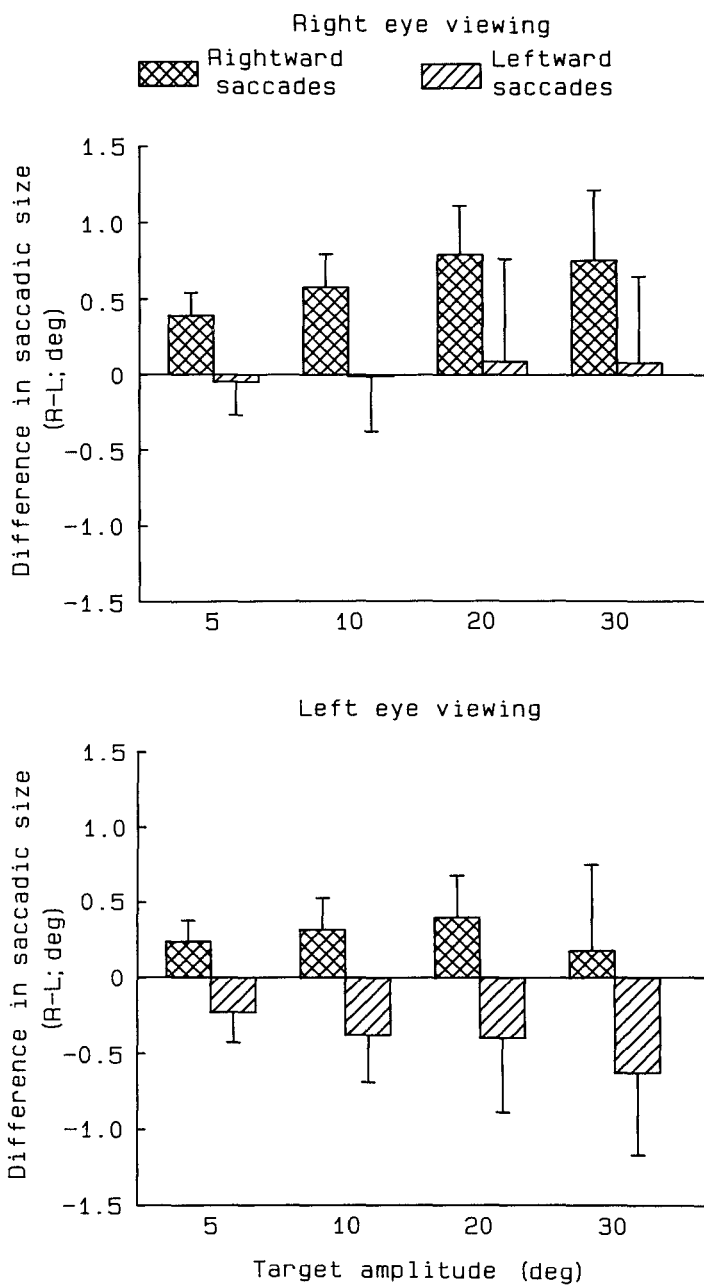
**Fig. 5.3** Mean velocities of post-saccadic drift (+ SD) of horizontal saccades of both the adducting eye and the abducting eye in binocular viewing at all four target amplitudes. Positive values indicate onward drift; negative values indicate backward drift.

eyes converged with higher drift velocities at larger target amplitudes. Mean velocities of this converging drift were about 0.3 deg/s at a target amplitude of 5 deg and up to about 1 deg/s at my largest target amplitude (30 deg). These results are in close agreement with findings reported by Kapoula et al. (1986) and Collewyn et al. (1988a). Within approximately 300 ms after saccadic offset, the angle of vergence reached its pre-saccadic value. Note that these results relate to experiments in which the stimuli did not require any vergence-changes.

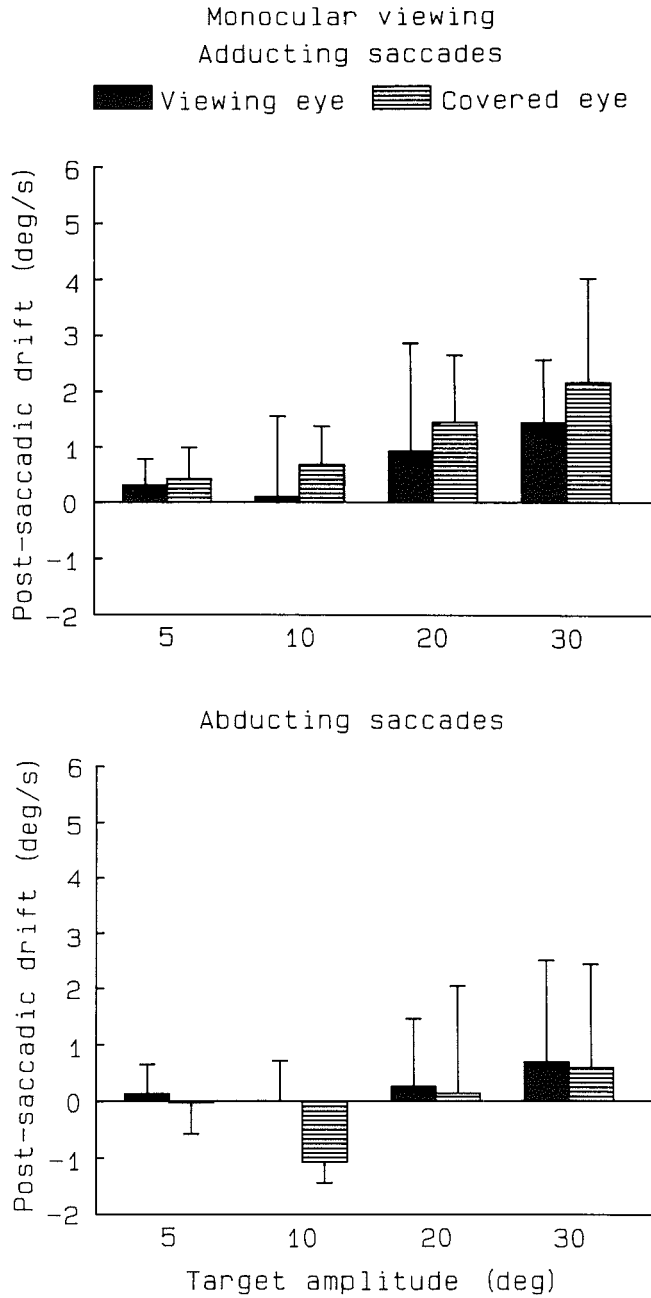
#### *Horizontal saccades - monocular viewing*

When one eye was covered, it made saccades that were, on average, about 0.3 deg smaller than those made by the fellow, viewing eye ( $F_{2,16} = 22.9$ ;  $P < 0.0005$ ). This effect was additional to the naso-temporal asymmetry that was described above. Therefore, when the viewing eye made an abducting saccade, it was up to about 0.6 deg larger than the adducting saccade of the covered eye (Fig. 5.4). However, adducting saccades of the viewing eye were accompanied by about equally large saccades of the covered, abducting eye. Because some of the subjects showed larger size-differences for rightward saccades than for leftward saccades, the mean effects of covering one eye are less clear in the lower panel of Fig. 5.4 (left eye viewing) than in the upper panel of this figure (right eye viewing). In addition to the effects of monocular viewing on saccadic size of the covered eye, the saccades of the viewing eye were also smaller when compared with binocular viewing ( $F_{1,8} = 24.4$ ;  $P < 0.001$ ). This size reduction was about 0.2 deg, and it became less at larger target amplitudes.

The onward post-saccadic drift associated with adducting saccades was also affected by the viewing condition. During monocular viewing, the onward post-saccadic drift of adducting saccades of the covered eye had a mean velocity that was about 0.5 deg/s higher than the post-saccadic drift of adducting saccades of the viewing eye ( $F_{1,8} = 9.20$ ;  $P < 0.05$ . Figs 5.2, 5.5). This contrasts with findings by Collewyn et al. (1988a), who reported no difference in post-saccadic drift between monocular and binocular viewing. The post-saccadic drift of the viewing eye, following adducting saccades, however, was the same as with binocular viewing. The post-saccadic drift that occurred in the covered eye frequently persisted until the next primary saccade, which contrasts with binocular viewing in which the onward drift virtually came to a halt within



**Fig. 5.4** Mean size-differences (+ SD) between horizontal saccades of the two eyes during monocular viewing. Upper panel: right eye viewing; lower panel: left eye viewing. Size-differences were calculated as in Fig. 5.1.

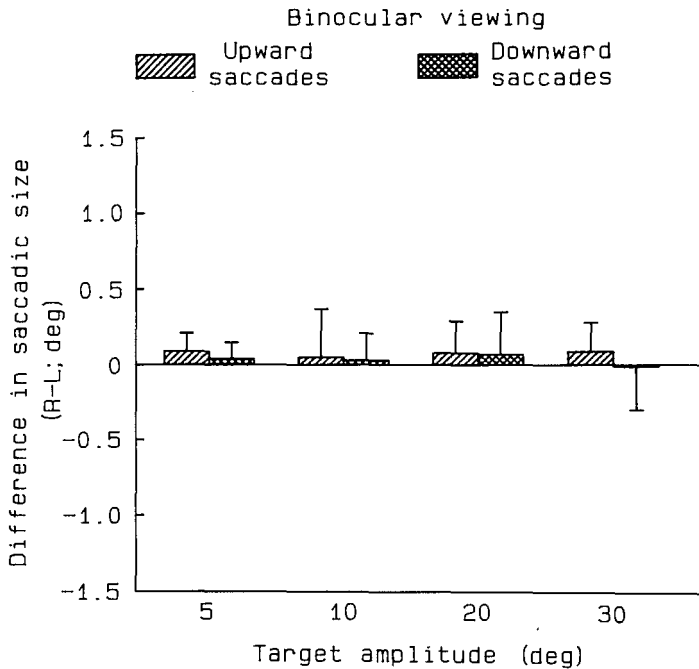


**Fig. 5.5** Mean velocities of post-saccadic drift (+ SD) of horizontal saccades during monocular viewing. Upper panel: adducting saccades; lower panel: abducting saccades. Positive values indicate onward drift; negative values indicate backward drift.

about 300 ms. Occasionally, post-saccadic drift of the covered eye was directed towards one side, throughout an entire trial, irrespective of the saccade direction. The post-saccadic drift associated with abducting saccades in binocular viewing was not consistently affected by covering of one eye, either in the covered eye, or in the viewing eye (cf. Fig. 5.5 with Fig. 5.3).

*Vertical saccades - binocular viewing*

During binocular viewing, vertical saccades had virtually the same magnitudes in each of the two eyes (Fig. 5.6). Therefore, the conjugacy of vertical saccades was better than the conjugacy of horizontal saccades (cf. Fig. 5.6 with Fig. 5.1). The degree of yoking was the same for upward saccades as for downward saccades. However, downward saccades were systematically larger than upward saccades between the same targets



**Fig. 5.6** Mean size-differences (+ SD) between vertical saccades of the left and the right eye during binocular viewing, calculated as the size of a saccade of the left eye subtracted from the size of a fellow saccade of the right eye, at all four target amplitudes.

( $F_{1,8} = 26.3$ ;  $P < 0.001$ ). The mean size-difference between upward and downward saccades increased with the target amplitude. This difference was on average about 0.3 deg at the smallest target amplitude (5 deg) and about 2 deg at the largest target amplitude (30 deg). Furthermore, downward saccades frequently overshoot their target, whereas upward saccades virtually never showed saccadic overshoot. Post-saccadic drift was predominantly upward after upward saccades (Fig. 5.7). Its mean velocity varied on average between about 1.0 and 2.5 deg/s, which was about 2 times higher than the post-saccadic drift-velocities of horizontal, adducting saccades during binocular viewing (cf. Fig. 5.7 with Fig. 5.3). After downward saccades post-saccadic drift was also predominantly upward, although less consistently. The mean drift-velocity was lower by about 0.8 to 2.4 deg/s when compared to the post-saccadic drift-velocities of upward saccades ( $F_{1,8} = 6.83$ ;  $P < 0.05$ )(Fig. 5.7). In contrast with horizontal saccades, the post-saccadic drift-velocity was independent of the target amplitude. There was no significant difference between the drift of the two eyes.

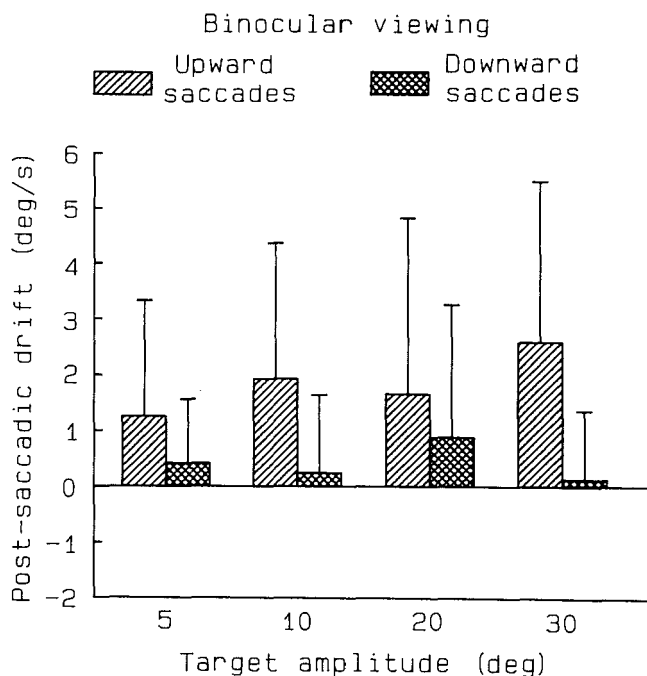
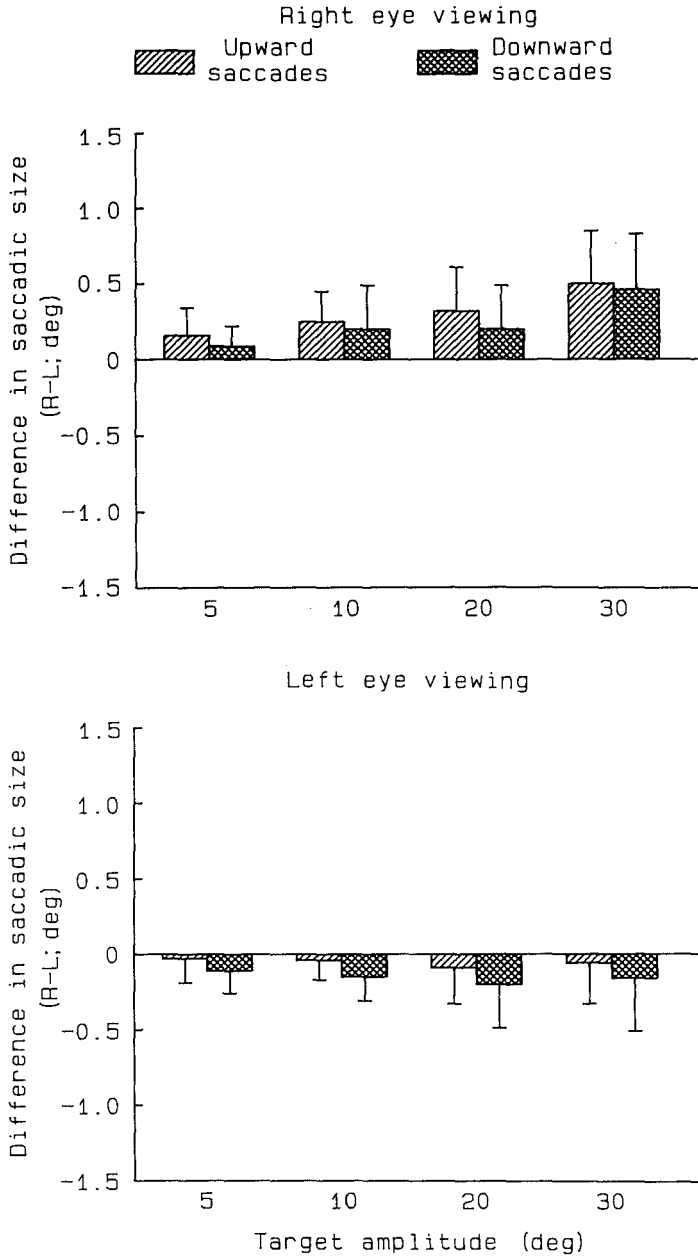
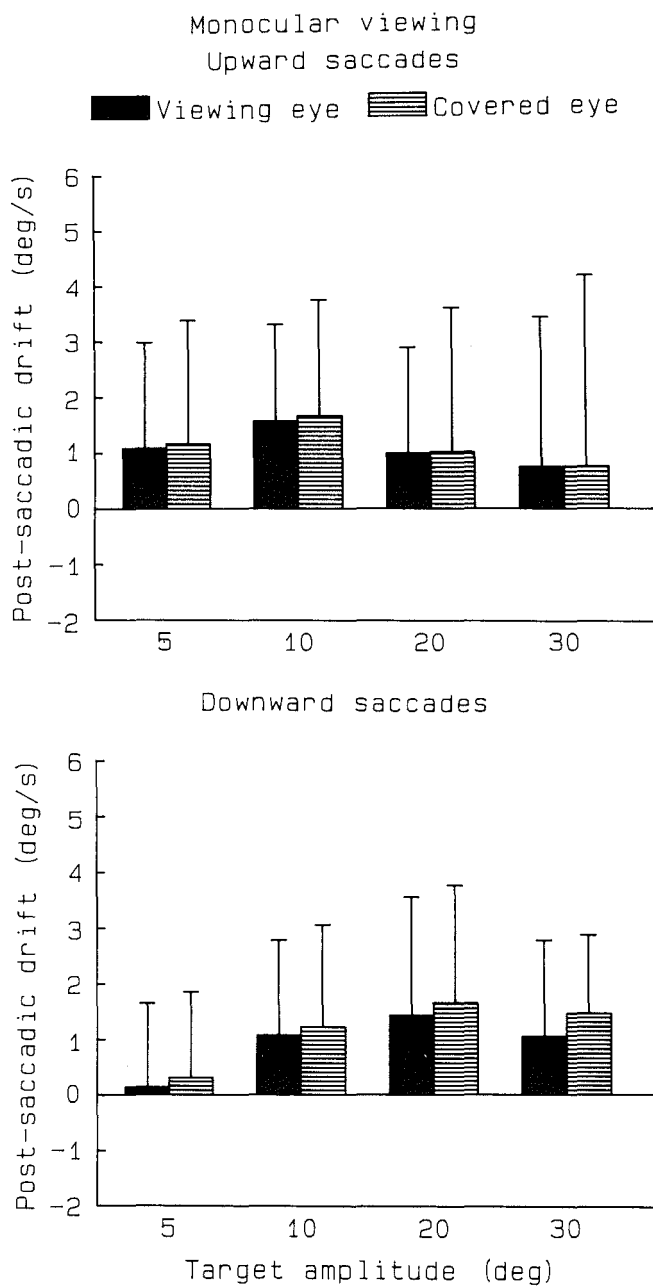


Fig. 5.7 Mean velocities of post-saccadic drift (+ SD) of vertical saccades in binocular viewing. Positive values indicate upward drift; negative values indicate downward drift.



**Fig. 5.8** Mean size-differences (+ SD) between vertical saccades of the left and the right eye with the right eye viewing (upper panel) or with the left eye viewing (lower panel). Size-differences were calculated as in Fig. 5.6.





**Fig. 5.9** Mean velocities of post-saccadic drift (+ SD) of vertical saccades during monocular viewing. Upper panel: upward saccades; lower panel: downward saccades. Positive values indicate upward drift; negative values indicate downward drift.

### *Vertical saccades - monocular viewing*

When one eye was covered (Fig. 5.8), it made saccades that were about 0.2 deg smaller than those of the viewing eye, in both upward and downward direction ( $F_{2,16} = 29.7$ ;  $P < 0.0005$ ). Because the saccadic size-difference between the two eyes was calculated as the magnitude of the saccade of the left eye subtracted from the magnitude of the fellow saccade of the right eye, the effects of covering one eye on the magnitude of its saccades are reflected by positive size differences during right eye viewing (Fig. 5.8, upper panel) and negative size differences during left eye viewing (Fig. 5.8, lower panel). These differences were statistically independent of the target amplitude. The saccades of the viewing eye were equally large as during binocular viewing. In some subjects, the difference in saccade size between the viewing eye and the covered eye was larger when one eye was covered than when the other eye was covered. Post-saccadic drift during monocular viewing was, for upward saccades (Fig. 5.9, upper panel) the same as during binocular viewing (Fig. 5.7). In contrast, post-saccadic drift of downward saccades had higher mean velocities (Fig. 5.9, lower panel) than when viewing was binocular ( $F_{2,16} = 17.5$ ;  $P < 0.0005$ ). This difference became larger with the target amplitude and ranged between about 0.1 deg/s at a target amplitude of 5 deg up to about 1 deg/s at a target amplitude of 30 deg (cf. Fig. 5.9 with Fig. 5.7). As with binocular viewing, post-saccadic drift of vertical saccades was conjugate.

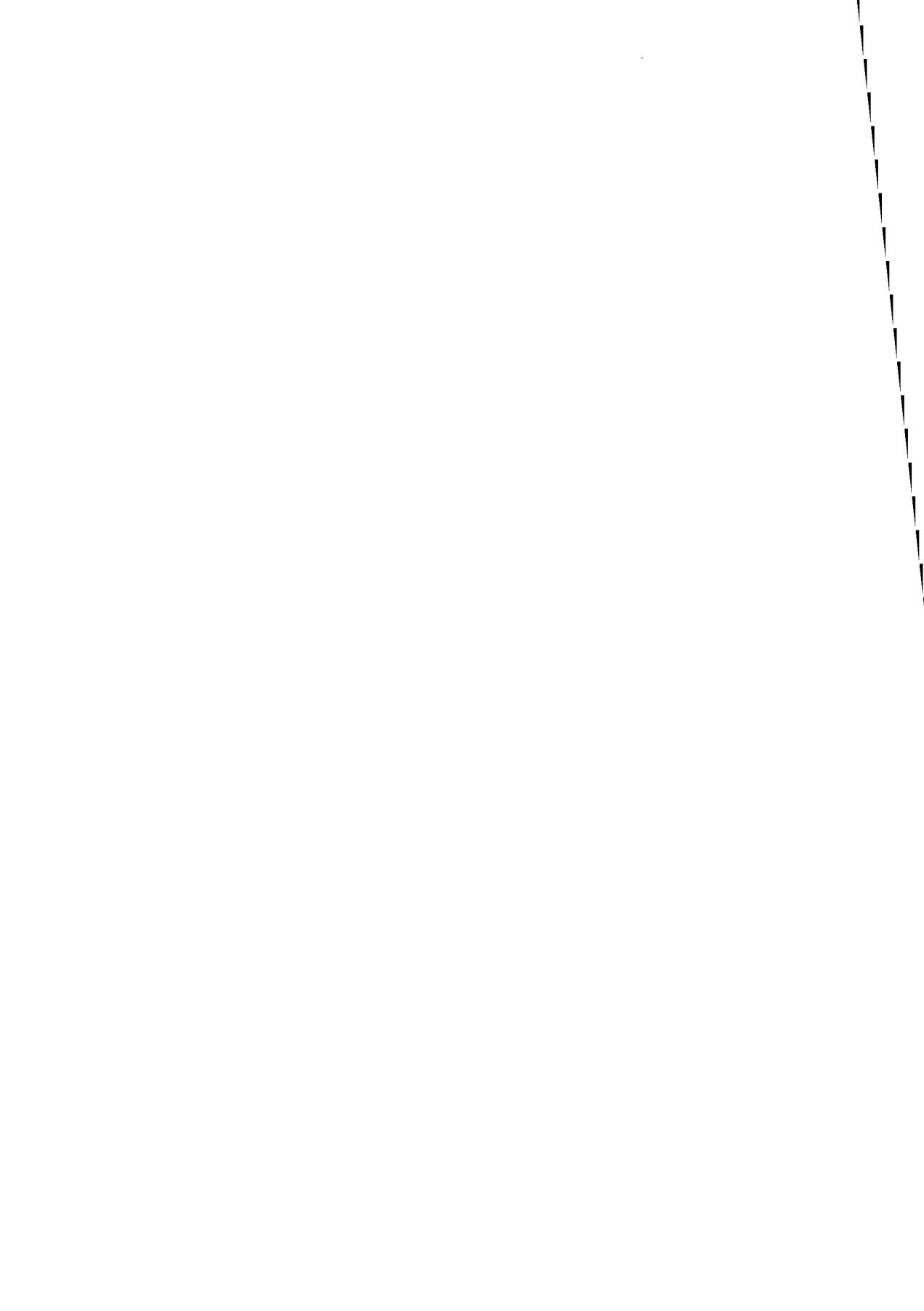
## DISCUSSION

This discussion will be confined to those aspects of the present results that are of direct pertinence to studying asymmetrical adaptations to anisometric spectacles. My results show that normal saccades, both horizontal and vertical, are not perfectly conjugate, even when the positions of the targets per se do not call for disjunctive eye movements. This contrasts with the generally held view that saccades are always of equal size, a notion that is frequently referred to as Hering's law of equal innervation (for a discussion on Hering's law, see Chapter 2). The present results confirm and extend similar findings by Collewijn et al. (1988a,b). In horizontal saccades, the yoking of the two eyes depends on the direction of the saccades and also on whether viewing is binocular or monocular. In vertical saccades, the coordination of the two eyes depends only on the viewing condition. Departures from perfect yoking are, however, small: they

are virtually always less than about 0.6 deg.

Nonetheless, the degree of yoking of saccades can only be used as a reliable measure of asymmetrical adaptation in relation to the present results. In other words, imperfect yoking does not necessarily have to result from asymmetrical adaptation. In order to accurately assess the degree of such asymmetrical adaptation, it is therefore best to study comparable saccades before and after adaptation. For a clear assessment, the number of data should also be balanced, i.e., the numbers of saccades that are compared should be equally large.

However, if no pre-adaptation data are available, such as in subjects who have been wearing anisometric spectacles for many years (Chapter 6), this problem can also be solved by carefully balancing the data. Mean values of the degree of yoking will be least affected by naso-temporal asymmetries when the numbers of saccades to one side are matched by equal numbers to the opposite side. Likewise, the effects of systematic asymmetries on mean values will be least when saccades made with one eye covered are matched by equal numbers made with the contralateral eye covered. The experimental design should meet these requirements. Obviously, these considerations apply also to the study of the effects of asymmetrical adaptations on post-saccadic drift.



## CHAPTER 6

### LONG-TERM ASYMMETRICAL ADAPTATION

#### INTRODUCTION

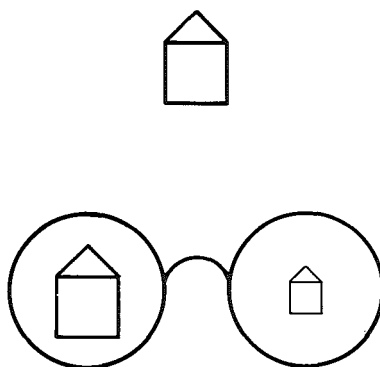
In a recent paper, Erkelens et al. (1989b) reported on a subject who had been wearing anisometropic spectacles for about 40 years. They found that he made saccades that were of unequal size in the two eyes, thus violating Hering's law of equal innervation. This asymmetrical adaptation was attributed to the unequal size of the images on each of the two retinas, as a result of the unequal refractive powers of each of the two lenses of his anisometropic spectacles. For vertical saccades, this long-term asymmetrical adaptation was almost perfect, i.e., the difference in saccadic amplitude was very close to that called for by the spectacles. Horizontal saccades, however, were less perfectly adapted. The adaptation of horizontal saccades increased with the target amplitude from about 40% for amplitudes of 5 deg to about 75% for amplitudes of 60 deg. Erkelens et al. (1989b) also mentioned a very small change in post-saccadic drift. This contrasts with the marked post-saccadic drift associated with palsies of one or more external eye muscles, either caused by disease or brought about experimentally (Kommerell et al., 1976; Abel et al., 1978; Optican and Robinson, 1980; Optican et al., 1985; Snow et al., 1985) (for a review, see Chapter 2).

In this chapter, I shall report on extensions of experiments as started by Erkelens et al. (1989b). Saccades of eight habitual anisometropic spectacle-wearers will be examined. I shall focus on size-differences between the saccades of the two eyes, and also on post-saccadic drift. In addition, I shall examine whether asymmetrical adaptations were also expressed in smooth-pursuit eye movements. First, however, I shall deal with some relevant basic principles of spectacle-lenses, and the way they affect the size of retinal images.

## FUNDAMENTAL CONSIDERATIONS ON SPECTACLE-LENSES

Spectacle-lenses, like other lenses, refract light, which is why they are widely used to correct various refractive anomalies of the eyes. Refractive powers of lenses are commonly expressed in diopters. A diopter is defined as the reciprocal of the focal length of a lens, expressed in meters. A positive dioptric value indicates that the lens converges light-rays, whereas a negative value indicates that the lens diverges light-rays. As a consequence of their refractive power, positive spectacle-lenses also magnify the visual image on the retina. Negative spectacle-lenses reduce the size of the retinal image. The degree of magnification or reduction depends on many factors in a rather complex way, which will not be discussed in detail (for a comprehensive treatise, see Bennett and Francis, 1962; Southall, 1937). In essence, the amount of magnification or reduction increases proportionately with the refractive power of the lens and also with the distance between the lens and the nodal point of the eye. In practice, it is the distance between the lens and the anterior surface of the cornea, rather than between the lens and the nodal point of the eye, which determines the amount of magnification. In addition, the degree of magnification or reduction increases proportionately with the thickness of the lens, although this effect is relatively small in normal glasses. Because the distance between the lens and the nodal point of the eye is larger with spectacles than with contact-lenses, and, to a lesser extent, because spectacle-lenses are thicker than contact-lenses, spectacle-lenses affect retinal image-size very much more than contact-lenses with the same refractive powers (Bennett and Francis, 1962).

In subjects wearing anisometric spectacles, i.e., spectacles with lenses of unequal refractive powers, the images on the two retinas are unequal in size. This size-difference is also referred to as *aniseikonia*. The aniseikonia increases with the anisometropia, which is, by definition, the difference in refractive power between the two spectacle-lenses. Furthermore, aniseikonia increases with the distance between the anisometric spectacle-lenses and the nodal points of the two eyes. As a consequence of this aniseikonia, angular target separations are larger in the larger retinal image than in the smaller retinal image. Therefore, gaze shifts between two binocularly foveated visual targets require larger movements of the eye with the larger retinal image than of the fellow eye. This is also illustrated in Fig. 6.1.

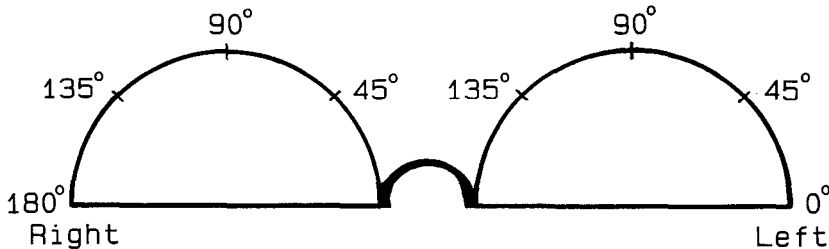


**Fig. 6.1** Schema of the effects of anisometric spectacles on the size of the visual image for each of the two eyes. The left side of the spectacle-frame is not provided with a lens. The right side is supplied with a negative, spherical lens. The house, as seen through these spectacles, is normally sized in the left eye, and scaled down in the right eye. Suppose a saccade were made from the left wall of the house to its right wall. The left eye would then have to make a normally sized saccade, whereas the right eye would, ideally, have to make a smaller saccade because the angular distance between the two walls is, for the right eye, smaller than for the left eye.

As already mentioned, the distance between the spectacle-lens and the nodal point of the eye affects the size of the retinal image. The ideal change in the size of an eye movement imposed by a spectacle-lens, is, however, more directly related to the slightly larger distance between the spectacle-lens and the centre of rotation of the eye, than to the distance between the spectacle-lens and the nodal point of the eye.

With anisometric contact-lenses, however, the situation is very different. One difference is that the aniseikonia associated with anisometric contact-lenses is much smaller than with equally anisometric spectacles, largely because the distance between the contact-lens and the nodal point of the eye is smaller than with spectacles. More important, however, is the fact that all contact-lenses, both anisometric and isometric (i.e., equally powerful) move along with the eyes, in contrast to spectacle-lenses, which remain fixed to the head. As a consequence, contact-lenses, either anisometric or isometric, do not require that the eyes move differently from uncorrected eyes.

In the present context it is also important to distinguish between various kinds of spectacle-lenses. *Spherical lenses* have equally strong refractive powers in all meridians. In lens-prescriptions their refractive powers (expressed in diopters) are preceded by the letter S. *Planocylindrical lenses*, however, refract maximally in one meridian and virtually not in the orthogonal meridian. The latter meridian is also referred to as the *cylinder-axis*, or *axis*, for short. The refractive power of a planocylindrical lens is proportional to the sine of the angle subtended by the cylinder-axis and the meridian under consideration. The orientation of a cylinder-axis in the fronto-parallel plane is prescribed, for both eyes, in terms of its angle in relation to a horizontal line in the same plane, as illustrated in Fig. 6.2.



**Fig. 6.2** Schema for the convention for the orientation of the cylinder-axis of a spectacle-lens as used in prescriptions.

The maximal refractive power of planocylindrical lenses (expressed in diopters) is preceded by the letter C in lens-prescriptions. *Spherocylindrical lenses* can be thought of as a spherical lens combined with a planocylindrical lens. The refractive power of a spherocylindrical lens in every meridian equals the sum of the refractive power of the spherical lens and the refractive power of the same meridian in the planocylindrical lens. Lens-prescriptions indicate refractive powers of both the spherical and the cylindrical components, as well as the orientation of the axis.



## METHODS

### *Subjects*

Nine subjects participated in these experiments. None of them had any history of ocular or oculomotor pathology. All of them had asymmetrical refractive anomalies, which had been corrected by anisometric spectacles for many years. Visual acuities were, in all subjects, when wearing their own corrections, 5/5 or better. The anisometropias were, on average, 2 diopters or more. In one subject (PA) the anisometropia was less than 1 diopter in the horizontal meridian, but more than 2 diopters in the orthogonal meridian. Two subjects (CR and CB) normally wore their spectacles all day through, whereas all other subjects used to wear them for several hours a day. The individual lens-prescriptions at the time of the experiments are presented, for all subjects, in Table 6.1. Age and sex of each subject, as well as the time of wearing of the spectacles, both in terms of the number of years and the amount of time every day during the last three months prior to the experiments are also presented in the table.

**Table 6.1** Lens-prescriptions and additional data of subjects

Sub	Age	Sex	Wearing time		Prescription left lens	Prescription right lens			
			years	/day					
KH	55	F	±40	SH*	S-1.25	S-3.75,	C-1.0,	axis 90 deg	
CR	73	F	51	AD*	S-2.75, C-0.75,	axis 170 deg	S+0.75, C-1.0,	axis 10 deg	
PJ	46	M	±35	SH	S+1.0	S-2.25,	C-0.5,	axis 155 deg	
PA	39	F	25	SH	S-1.25, C-2.0,	axis 85 deg	S+1.5, C-5.0,	axis 80 deg	
CB	46	F	42	AD	S-2.0	S-9.0,	C+5.0,	axis 65 deg	
MB	41	F	32	SH	S-1.25, C-1.5,	axis 10 deg	S-5.0,	C-1.25,	axis 10 deg
GP	48	F	2	SH	S+3.5, C-1.5,	axis 10 deg	S+0.25		
MJ	33	F	19	SH	S-3.0, C-0.5,	axis 100 deg	S-1.0,	C-0.5,	axis 70 deg
HH	61	M	±40	SH	S-3.5, C-1.0,	axis 100 deg	S+0.25		

\* SH = Several hours a day; AD = All day through

### *Experimental procedures and data analysis*

During the experiments, all subjects wore their own anisometric spectacles. The experiments were run as described in detail in Chapter 5. In short, horizontal and vertical saccades were made at a comfortable pace, marked by an auditory signal, between stationary targets that were positioned 5, 10, 20 or 30 deg apart, symmetrically

about the straight-ahead position. The positions of the targets contained no stimulus for disjunctive eye movements. Viewing was binocular or monocular with either eye. The order of the trials was randomised for every subject. In addition, subjects were asked to follow a target that made a circular, uniform movement, either binocularly or with either eye covered. Again, disjunctive eye movements were not called for by the target-positions. The movements of both eyes were recorded simultaneously by means of sensor coils. All recordings were analyzed by computer programmes. The number of data was balanced for the two meridians, the four target amplitudes, the three viewing conditions and the two directions of the saccades for either meridian. For statistical analysis, these data were submitted to a statistical computer programme (SPSS-X), which was used to compute mean values and also to test any observed differences by means of a multivariate analysis of variance (MANOVA). As it turned out that one subject (GP) had cooperated poorly, by frequently not looking at the appropriate visual targets, her data were disregarded.

I used size-differences of concomitant saccades, instead of saccade-sizes per se, as a measure of the degree of adaptation. This approach was chosen for two reasons: 1) the occurrence of saccadic undershoot would make it difficult to determine the degree of asymmetrical adaptation from comparing the actual saccadic size with the required gaze-shift of each eye, and 2) the variability of saccadic size of each eye, expressed in standard deviations, would be a meaningless measure of asymmetrical adaptation, as opposed to the variability of differences in saccadic size.

As a final comment on my methods, some displacement of the spectacles on the head was likely to occur during the running of the present experiments, which would consequently affect the position of the targets as viewed through the spectacles. Therefore, it was not possible to assess where the targets were seen at all times by each of the two eyes. For that reason, I refrained from measuring position-errors at saccadic offset. I shall, for the same reason, also refrain from plotting target-positions in any of the figures.

## RESULTS

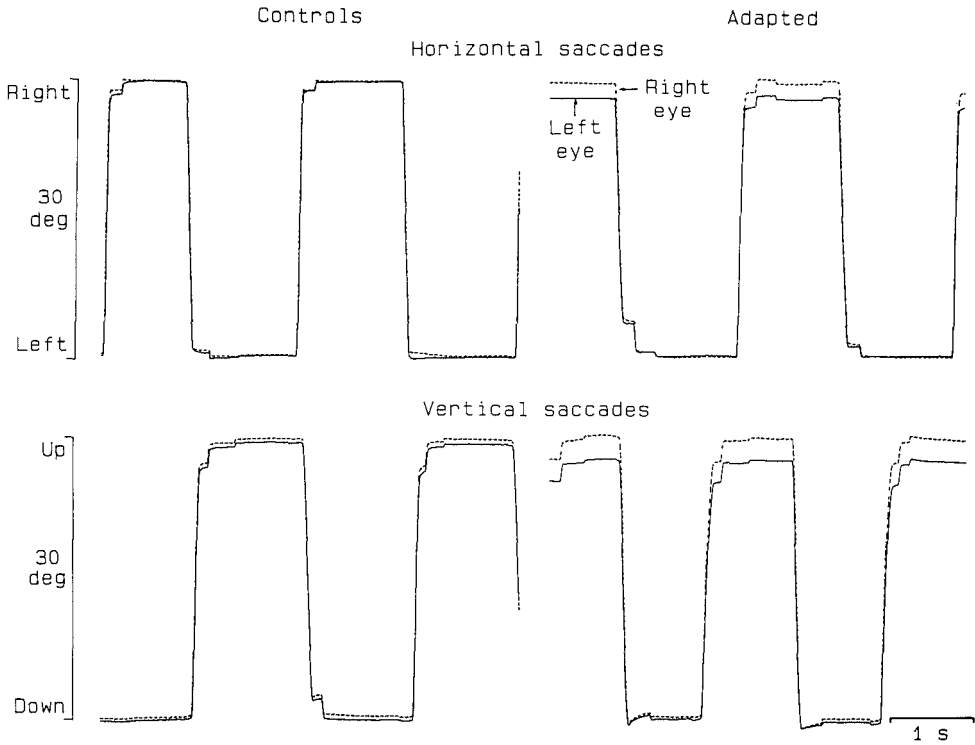
### *Saccadic size*

In all subjects, the saccades of the two eyes were unequal in size, thus reflecting asymmetrical adaptation to the anisometric spectacles ( $F_{1,7} = 83.3$ ;  $P < 0.0005$ ). These asymmetrical adaptations were present in horizontal, as well as in vertical saccades, both during binocular and monocular viewing, which confirms similar findings by Erkelens et al. (1989b). Moreover, these results violate Hering's law of equal innervation in the sense that the eyes make saccadic movements that are different in size. I did not observe any differences in asymmetrical adaptation between those subjects who wore their spectacles all day through and those who wore them intermittently. Figure 6.3 presents typical recordings of concomitant saccades of both eyes in either meridian during monocular viewing (right eye covered), at a target amplitude of 30 deg. For comparison, typical recordings of normal, unadapted saccades of both eyes (left eye viewing) of a control subject, made under similar conditions, have been added to the figure (left panels). These controls were obtained from the experiments described in Chapter 5. It is evident from Fig. 6.3 that the size-difference between saccades of the two eyes can become very large after asymmetrical adaptation. In this case they were on the order of 1.7 deg for horizontal saccades and 2.6 deg for vertical saccades, at a nominal target amplitude of 30 deg.

I have tabulated the mean size-differences between saccades of the two eyes for every subject in Table 6.2. Distinctions were made between horizontal and vertical saccades, monocular and binocular viewing and also between the four target amplitudes. Size-difference was calculated as the size of the saccade of the eye that was required to make the larger saccade (larger movement eye), minus the size of the saccade of the contralateral eye (smaller movement eye). It can be seen from Table 6.2 that saccadic size-differences between the two eyes generally increased with the target amplitude ( $F_{3,21} = 61.3$ ;  $P < 0.0005$ ), which agrees well with the requirements of the glasses. In addition, the saccadic size-differences were generally larger during binocular viewing than during monocular viewing ( $F_{2,14} = 7.48$ ;  $P < 0.01$ ). This was true for both horizontal and vertical saccades. Although hard-programmed asymmetrical adaptations are better reflected by saccadic size-differences between the two eyes during monocular viewing than during binocular viewing, I shall nonetheless also present the asymmetries that occurred during

**Table 6.2** Mean differences in saccadic size (+ SD) between the two eyes (deg)

Sub	Target amp.	Horizontal saccades				Vertical saccades			
		Monoc. view.		Binoc. view.		Monoc. view.		Binoc. view.	
KH	5	0.31	(0.13)	0.35	(0.11)	0.34	(0.23)	0.33	(0.17)
	10	0.56	(0.16)	0.93	(0.24)	0.47	(0.26)	0.68	(0.31)
	20	0.94	(0.36)	1.08	(0.38)	0.96	(0.34)	0.95	(0.26)
	30	0.68	(0.55)	1.91	(0.20)	1.21	(0.42)	1.36	(0.31)
CR	5	0.16	(0.31)	0.24	(0.18)	0.17	(0.15)	0.31	(0.16)
	10	0.26	(0.48)	0.49	(0.24)	0.63	(0.20)	0.56	(0.31)
	20	0.87	(0.30)	0.99	(0.29)	1.83	(1.33)	1.45	(0.37)
	30	1.33	(0.37)	1.75	(0.47)	2.14	(0.41)	2.11	(0.14)
PJ	5	0.31	(0.46)	0.49	(0.27)	0.14	(0.12)	0.25	(0.08)
	10	0.56	(0.71)	0.79	(0.34)	0.22	(0.14)	0.51	(0.14)
	20	1.17	(0.89)	2.00	(0.56)	0.54	(0.21)	1.40	(0.26)
	30	1.66	(1.13)	2.86	(0.37)	0.97	(0.23)	2.45	(0.49)
PA	5	0.04	(0.15)	0.00	(0.13)	0.22	(0.09)	0.11	(0.11)
	10	-0.04	(0.20)	0.05	(0.05)	0.38	(0.13)	0.43	(0.07)
	20	0.13	(0.22)	0.14	(0.26)	1.02	(0.19)	0.93	(0.13)
	30	0.34	(0.38)	0.53	(0.21)	1.57	(0.44)	1.61	(0.25)
CB	5	-0.04	(0.28)	0.16	(0.24)	0.33	(0.13)	0.34	(0.07)
	10	0.08	(0.28)	0.31	(0.20)	0.78	(0.14)	0.80	(0.22)
	20	0.21	(0.43)	0.93	(0.18)	1.81	(0.30)	2.01	(0.12)
	30	0.71	(0.63)	1.53	(0.36)	2.48	(0.95)	2.93	(0.21)
MB	5	0.31	(0.28)	0.39	(0.24)	0.21	(0.14)	0.18	(0.09)
	10	0.55	(0.45)	0.71	(0.22)	0.40	(0.19)	0.34	(0.22)
	20	1.09	(0.53)	1.40	(0.20)	0.43	(0.26)	0.84	(0.07)
	30	1.41	(0.52)	1.98	(0.10)	0.71	(0.35)	1.23	(0.34)
MJ	5	0.10	(0.07)	0.10	(0.11)	0.00	(0.14)	0.05	(0.11)
	10	0.19	(0.18)	0.15	(0.18)	0.13	(0.13)	0.36	(1.12)
	20	0.34	(0.25)	0.36	(0.18)	0.22	(0.70)	0.24	(0.11)
	30	0.91	(0.48)	0.64	(0.37)	0.65	(0.33)	0.61	(1.18)
HH	5	0.11	(0.38)	0.30	(0.43)	0.09	(0.32)	0.19	(0.15)
	10	0.31	(0.62)	0.61	(0.66)	0.18	(1.44)	0.51	(0.27)
	20	0.88	(0.69)	1.68	(0.48)	0.88	(0.26)	1.06	(0.28)
	30	1.61	(0.86)	3.16	(0.40)	1.20	(0.30)	1.64	(0.53)



**Fig. 6.3** Typical recordings of control saccades (left panels) and asymmetrical saccades (right panels) of both eyes, made with only the left eye viewing in either meridian. Nominal target amplitude: 30 deg.

binocular viewing, because they reflect how well the eye movements were adapted to normal, i.e., binocular, viewing conditions. The size-difference between horizontal saccades of the two eyes could become as large as about 3.2 deg (subject HH) during binocular viewing. During monocular viewing, however, this size-difference was considerably smaller and equalled maximally about 1.6 deg (subjects HH and PJ). For vertical saccades, maximal saccadic size-differences between the two eyes were about 2.9 deg (subject CB) during binocular viewing and 2.5 deg (same subject) during monocular viewing. In subject PA the size-differences between horizontal saccades of the two eyes were very small, which agrees well with the small horizontal anisometropia of her spectacles (cf. Table 6.2 with Table 6.1).

**Table 6.3** Vergence-deficits at saccadic offset

Sub	Target amp.	Horiz. sacc.		Vert. sacc.	
		Monoc.	Binoc.	Monoc.	Binoc.
KH	5	0.05	0.01	-0.06	-0.05
	10	0.16	-0.20	0.11	-0.10
	20	0.49	0.36	0.20	0.21
	30	1.48	0.25	0.53	0.38
CR	5	0.15	0.07	0.26	0.12
	10	0.34	0.12	0.26	0.33
	20	0.34	0.22	-0.03	0.35
	30	0.49	0.06	0.54	0.57
PJ	5	0.21	0.04	0.48	0.37
	10	0.49	0.26	1.06	0.77
	20	0.93	0.09	2.04	1.18
	30	1.49	0.28	2.89	1.41
PA	5	0.05	0.09	0.06	0.16
	10	0.22	0.13	0.19	0.14
	20	0.23	0.22	0.12	0.22
	30	0.19	0.01	0.14	0.09
CB	5	0.41	0.21	0.22	0.22
	10	0.67	0.43	0.37	0.35
	20	1.28	0.56	0.51	0.30
	30	1.52	0.71	0.98	0.53
MB	5	0.22	0.14	0.10	0.13
	10	0.51	0.35	0.24	0.30
	20	1.03	0.72	0.86	0.44
	30	1.77	1.20	1.21	0.69
MJ	5	0.01	0.01	0.15	0.10
	10	0.03	0.07	0.19	-0.05
	20	0.10	0.08	0.41	0.40
	30	-0.24	0.03	0.30	0.34
HH	5	0.47	0.28	0.45	0.35
	10	0.85	0.54	0.94	0.60
	20	1.43	0.63	1.37	1.19
	30	1.86	0.30	2.16	1.73

As a next step I calculated the saccadic size-differences between the two eyes that were actually required for making a saccade from one binocularly foveated target to another binocularly foveated target. To that end I first measured the movement-angle covered by the monocularly viewing left or right eye during gaze-changes between two targets made with the spectacles on. The angular difference between the two eyes, calculated as the larger movement of one eye minus the smaller movement of the fellow eye, made between the same targets, was considered to equal the required saccadic size-difference between the two eyes for that specific target amplitude. Thereafter, I subtracted the actual size-difference between concomitant saccades of the two eyes from the required size-difference. This difference between required and actual saccadic size-difference between the two eyes was defined as the vergence-deficit. Mean vergence-deficits are tabulated in Table 6.3. The standard deviations have been left out of Table 6.3, because they equal the standard deviations in Table 6.2. Table 6.3 demonstrates that the vergence-deficit of horizontal saccades was almost always less than 1.0 deg during binocular viewing (mean value: 0.26 deg). During monocular viewing, however, the vergence-deficit at the end of horizontal saccades was, on average, more than twice as large (0.60 deg). Vertical saccades also showed smaller vergence-deficits during binocular viewing than during monocular viewing ( $F_{2,14} = 7,5$ ;  $P < 0.01$ ); mean values were 0.60 deg for monocular viewing and 0.43 deg for binocular viewing. Vergence-deficits generally increased with the target amplitude ( $F_{3,21} = 12.6$ ;  $P < 0.0005$ ). This increase was more prominent during monocular viewing than during binocular viewing ( $F_{6,42} = 4.81$ ;  $P < 0.0005$ ). The vergence-deficits of vertical saccades were, for all subjects taken together, not consistently different from the vergence-deficits of horizontal saccades ( $F_{1,7} = 0.18$ ;  $P > 0.5$ ), neither during binocular, nor during monocular viewing. However, within some subjects, the vergence-deficits associated with saccades in one meridian (either horizontal or vertical) were consistently larger than the vergence-deficits of saccades in the orthogonal meridian (Table 6.2). These differences between horizontal and vertical vergence-deficits were not clearly correlated with differences between the anisometropias along these two meridians.

Some subjects (HH and PJ) experienced double-images of the upper targets, notably at larger target amplitudes, which indicates that asymmetrical adaptation was inadequate in the upper oculomotor field. This corresponds well with their large vergence-deficits (more than 1 deg) associated with vertical saccades during binocular viewing. Targets in

the lower oculomotor fields, as well as all targets positioned along the horizontal meridian, were never seen as double-images.

The size-differences between saccades of the two eyes that were required by the spectacles amounted, on average, to about 2.4% for every diopter of anisometropia, when the orientations of the cylinder-axes had been taken into account. However, this percentage was very variable and ranged between a minimum of about 1.2% and a maximum of about 3.4%. I attribute this variability largely to the various distances between the spectacle-lenses and the centres of rotation of the eyes among the different subjects. Therefore, the anisometropia per se was considered to be a poor parameter of the required size-differences between saccades of the two eyes. Thus, I compared the actual saccadic size-differences between the two eyes to the required size-differences, as measured from the viewing eye during monocularly viewing gaze-shifts with either eye. Individual means of saccadic size-differences (also presented in Table 6.2) have been plotted as a function of the required differences in saccadic size in Figs 6.4 (binocular

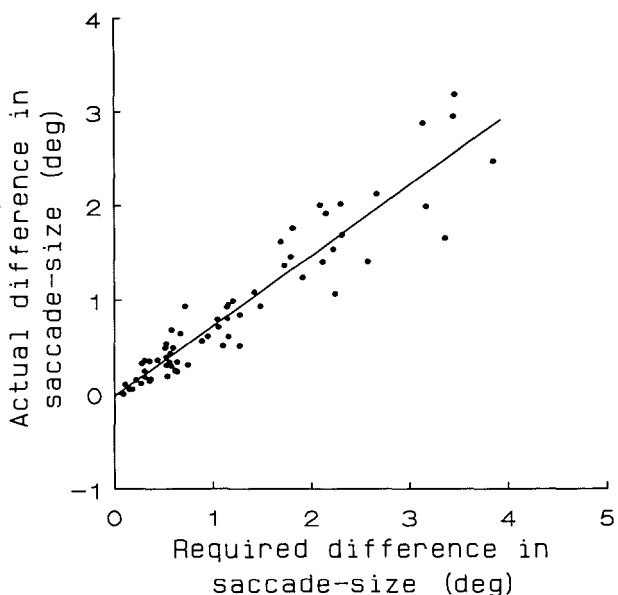


Fig. 6.4 Actual difference in saccadic size between the two eyes, plotted as a function of the required difference in saccadic size for all subjects and both meridians. Data relate to binocular viewing.



viewing) and 6.5 (monocular viewing). Because there were no significant differences between horizontal and vertical saccades with respect to the actual saccadic size-differences between the two eyes, saccades of both meridians have been pooled. During binocular viewing (Fig. 6.4), the overall average degree of adaptation was about 74%. During monocular viewing, however, the overall average of asymmetrical adaptation dropped to about 46% of what was required.

As a next step, I computed the individual degree of asymmetrical adaptation for every subject, expressed in the actual saccadic size-difference between the two eyes as a percentage of the required size-difference between the two eyes. Mean values of these percentages are presented in Table 6.4. This table demonstrates that the degree of asymmetrical adaptation varied considerably between and within subjects at the various target amplitudes. During monocular viewing, this percentage was only very rarely about the same for all four target amplitudes (e.g., subject PJ in both meridians, subject MB for horizontal saccades and subjects PA and CB for vertical saccades). More frequently,

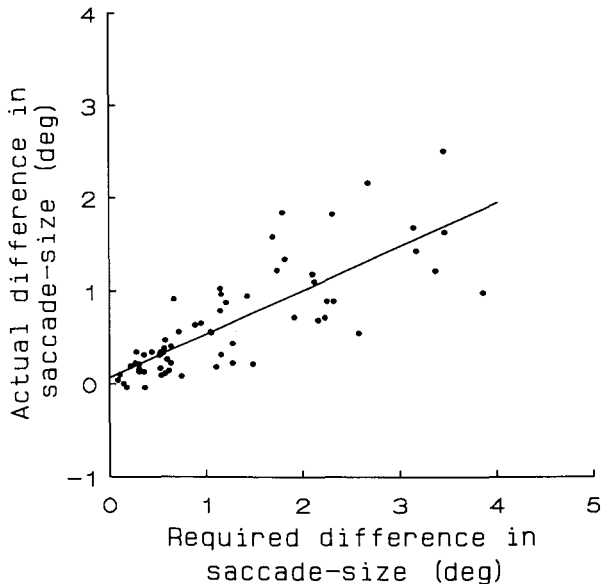


Fig. 6.5 As Fig. 6.4, for monocular viewing.

**Table 6.4** Percentages of asymmetrical adaptation

Sub	Target amp.	Horiz. sacc.		Vert. sacc.	
		Monoc.	Binoc.	Monoc.	Binoc.
KH	5	87	97	121	118
	10	78	127	81	117
	20	66	75	83	82
	30	32	89	70	78
CR	5	52	78	39	72
	10	43	80	71	63
	20	72	82	102	81
	30	73	96	80	79
PJ	5	60	93	23	40
	10	53	75	17	40
	20	56	96	21	54
	30	53	91	25	64
PA	5	49	0	80	41
	10	-18	28	66	75
	20	35	39	89	81
	30	65	99	92	95
CB	5	-10	44	60	61
	10	10	42	68	70
	20	14	62	78	87
	30	32	68	72	85
MB	5	58	73	67	57
	10	52	67	63	53
	20	51	66	33	65
	30	44	62	37	64
MJ	5	90	90	0	33
	10	84	68	40	116
	20	78	82	35	37
	30	118	96	68	65
HH	5	19	52	17	35
	10	26	53	16	46
	20	38	73	39	47
	30	46	91	36	49

this percentage either increased or decreased with the target amplitude. In many other cases, there was no systematic trend whatsoever within subjects. During binocular viewing, the degree of asymmetrical adaptation expressed as a percentage was also highly variable. In conclusion, the size-difference between saccades of the two eyes increased with the target amplitude, but this asymmetrical adaptation could not be expressed in a systematic percentage of the required asymmetrical adaptation.

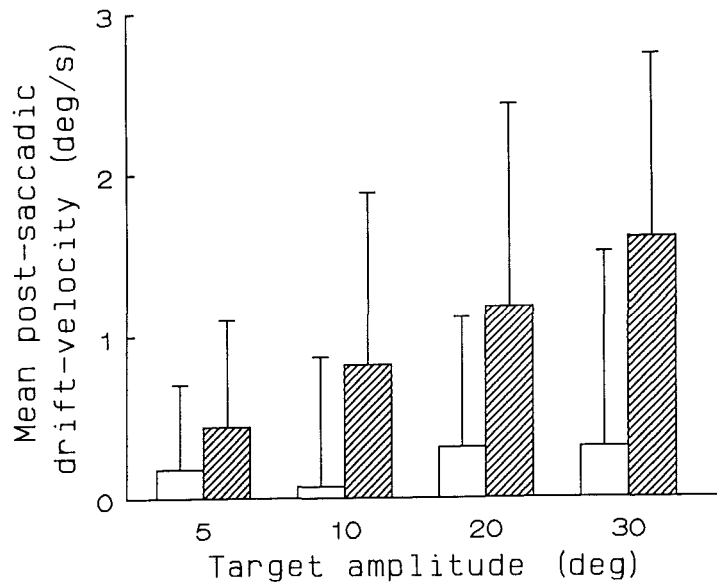
#### *Post-saccadic drift*

Post-saccadic drift of horizontal saccades was also asymmetrically adapted. Post-saccadic drift of vertical saccades, however, was not significantly different in the two eyes ( $F_{1,7} = 0.26$ ;  $P > 0.5$ ), and was also not different from the controls (Chapter 5). Following horizontal saccades, post-saccadic drift-velocities of the eye that made the larger saccades were higher than the post-saccadic drift-velocities of the eye that made the smaller saccades ( $F_{1,7} = 7.00$ ;  $P < 0.05$ ). This difference in post-saccadic drift-velocity between the two eyes was larger during binocular viewing than during monocular viewing ( $F_{2,14} = 12.0$ ;  $P < 0.001$ ). It averaged about 0.8 deg/s with both eyes viewing and about 0.3 deg/s with only one eye viewing (Fig. 6.6). The direction of the post-saccadic drift of the eye that made the larger saccade was such that it reduced the vergence-deficit that was present at saccadic offset. As already mentioned, this effect was most prominent during binocular viewing. The naso-temporal asymmetries of drift that normally occur (Chapter 5) were not present after asymmetrical adaptation ( $F_{1,7} = 2.59$ ;  $P > 0.1$ ). In other words, post-saccadic drift of asymmetrically adapted saccades was the same for adducting as for abducting saccades of each eye. Like with normal, unadapted saccades, mean post-saccadic drift-velocities increased with the target amplitude ( $F_{3,21} = 14.2$ ;  $P < 0.0005$ ). The asymmetry in post-saccadic drift of the two eyes, however, was independent of the target amplitude.

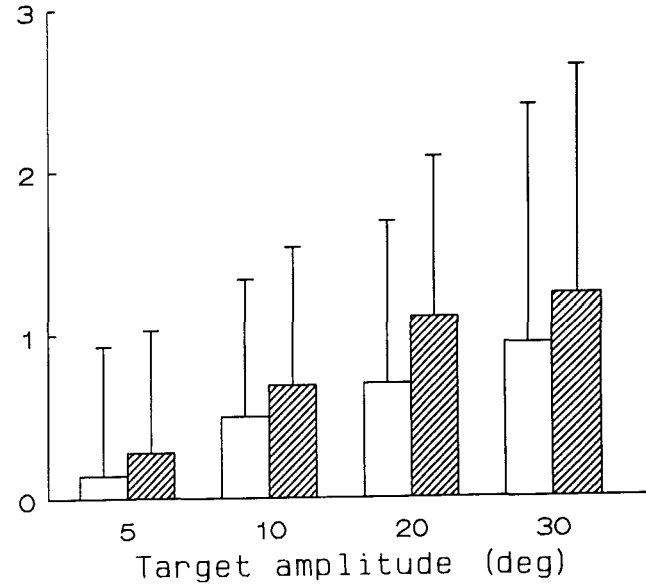
#### *Smooth pursuit*

When subjects tracked a target that made a uniform, circular movement (diameter: 30 deg; velocity: about 11 deg/s) the magnitudes of the eye movements were different in the two eyes. Some typical recordings, which demonstrate this asymmetrical adaptation of smooth pursuit eye movements, are presented in Fig. 6.7 (Subject HH). For

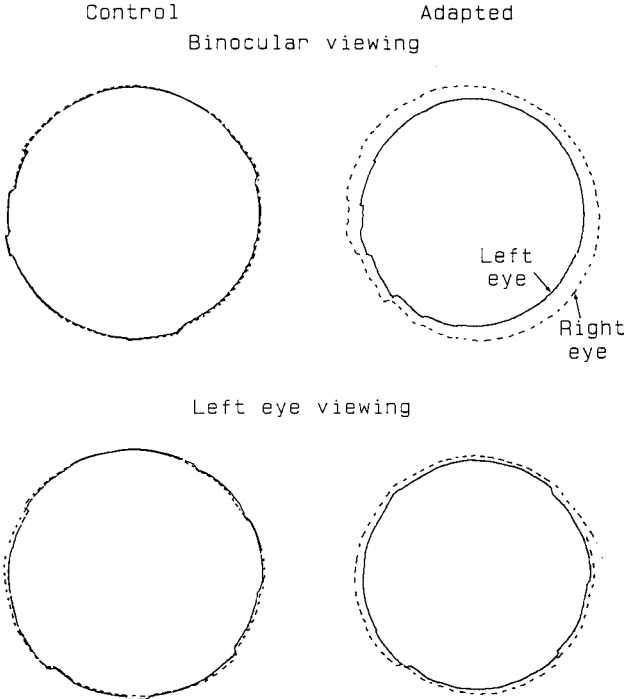
Binocular viewing



Monocular viewing



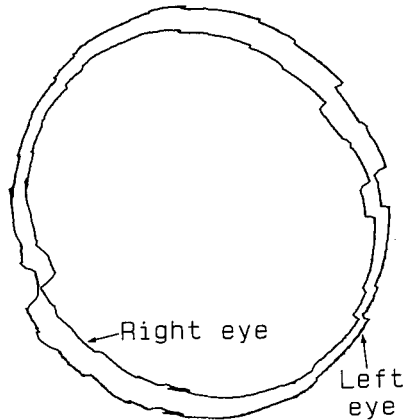
comparison with controls, recordings made under similar experimental conditions, derived from the experiments described in Chapter 5, are also included in the same figure. As I was not interested in systematic shifts in gaze due to any prismatic effects of the glasses or to phorias, I have, for clarity, plotted the recordings concentrically. Note that the subjects occasionally made saccades during the execution of the pursuit-task, which is a normal phenomenon.



**Fig. 6.7** Binocular recordings of smooth-pursuit eye movements, during binocular viewing (upper panels) and during monocular viewing (left eye viewing, lower panels). Control recordings are presented in the left panels; recordings after adaptation are shown in the right panels.

**Fig. 6.6** Mean post-saccadic drift-velocities (+ SD) at four target amplitudes, plotted for the eye that made the smaller saccades and for the fellow eye. Left panel: binocular viewing; right panel: monocular viewing.

Those subjects who wore spectacles with cylindrical lenses made elliptical eye movements, corresponding with the refractive powers and cylinder-axes of their glasses. One such example (subject CB) is presented in Fig. 6.8.



**Fig. 6.8** Binocular recordings made during the smooth-pursuit task in a subject with powerful cylindrical lenses. Binocular viewing.

I calculated the size-differences between the diameters of the movements of either eye along the horizontal, as well as the vertical meridian. As with saccadic size-differences, these differences in diameter were computed as the diameter of the movement of the eye that was expected to make the larger movement, minus the diameter of the movement of the fellow eye. These differences in diameter are presented in Table 6.5. Differences in diameter between movements of the two eyes were larger by about 0.9 deg during binocular viewing than during monocular viewing, along either meridian (paired Student t-test:  $P < 0.05$ ). As a next step, I computed the vergence-deficits, by subtracting the actual differences in diameter-size between the movements of the two eyes from the differences that were required by the spectacles. Vergence-deficits along one meridian were not significantly different from those along the orthogonal meridian (paired Student t-test:  $P > 0.05$ ), neither during binocular, nor during monocular viewing.

**Table 6.5** Differences in diameter between circular movements of the two eyes (deg)

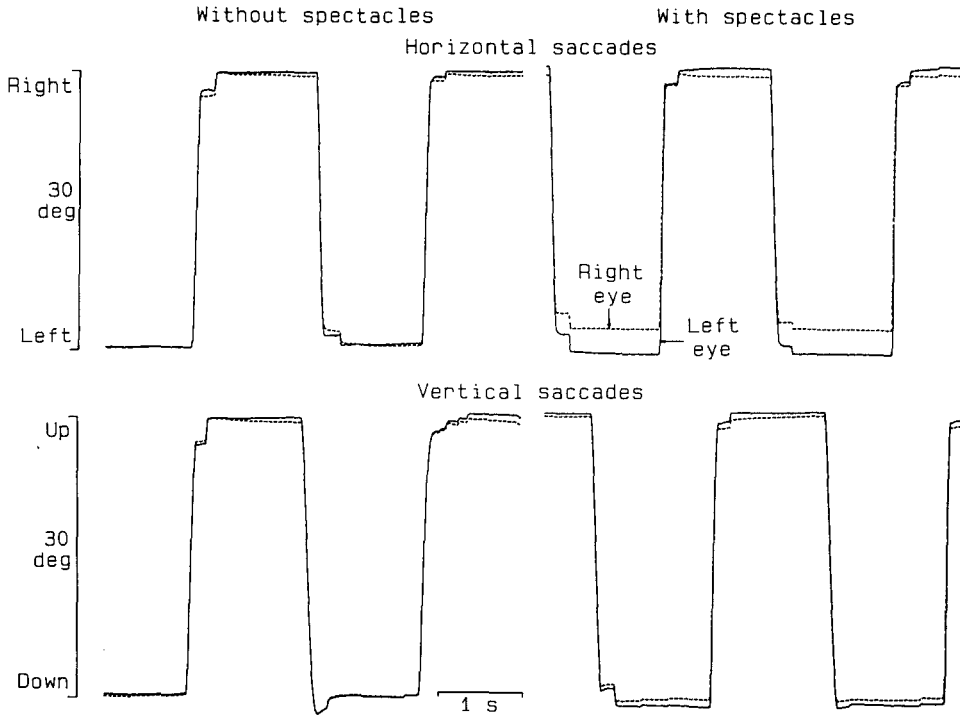
Sub	Horizontal diameter		Vertical diameter	
	Binoc. view.	Monoc. view.	Binoc. view.	Monoc. view.
KH	1.88	1.43	1.70	1.40
CR	1.96	2.20	2.69	2.55
PJ	3.68	1.60	4.31	1.93
PA	0.50	0.57	2.49	1.98
CB	2.13	0.96	3.21	2.54
MB	2.53	1.19	2.28	1.34
MJ	1.23	1.40	0.85	0.61
HH	3.56	1.14	3.19	0.87

I then compared the vergence-deficits of the asymmetrical smooth-pursuit eye movements to those of the asymmetrical saccades. With both eyes viewing, the vergence-deficits of smooth-pursuit eye movements were smaller by about 0.6 deg than those associated with saccades (horizontal as well as vertical) that were made between targets positioned equally far apart (30 deg) as the diameter of the circular target-movement (paired Student t-test:  $P < 0.05$ ). As with vertical saccades, subjects HH and PJ experienced double-images of the target in the upper oculomotor range. During monocular viewing, however, there was no significant difference in vergence-deficit between saccades and smooth-pursuit eye movements.

In conclusion, during binocular viewing, asymmetrical adaptation was more complete for smooth-pursuit eye movements than for saccades. During monocular viewing, however, there was no significant difference in the degree of asymmetrical adaptation between saccades and smooth-pursuit.

#### *Versatility of asymmetrical adaptation*

Subject PJ repeated the experiments on another day. This time, however, he did not wear his anisometric spectacles, which he had left off for about 1 hour prior to the experiment. It will be recalled that he normally wears them for only several hours a day,



**Fig. 6.9** Recordings of saccades made by subject PJ. Viewing was monocular with the left eye. Left panels present recordings made without spectacles. Right panels present recordings made with the subject wearing his own, anisometric spectacles.

and that his intermittent wearing of his spectacles therefore requires that he either make asymmetrical eye movements or normal eye movements, depending on whether he has his glasses on or not. Figure 6.9 presents recordings of saccades of his two eyes during monocular viewing, both with and without his own spectacles. It is clear from this figure that the size-differences between saccades of the two eyes that were present while he wore his spectacles were markedly reduced when he did not wear them. In both conditions, however, viewing was monocular and therefore contained no direct stimulus for saccades of unequal size. During binocular viewing, there were no significant size-differences between saccades of the two eyes, except for the temporo-nasal asymmetries that normally occur (see Chapter 5). Vertical saccades made with both eyes viewing did not result in double-images of the upper targets, such as occurred with his spectacles on.



Mean post-saccadic drift-velocities in the uncorrected condition were somewhat different from when he had his spectacles on. However, these changes were entirely inconsistent. Smooth eye movements, made with one eye covered, in pursuit of the circularly moving target, were smaller in his right eye than in his left eye, which would meet the requirements of his spectacles, although he did not wear them at that time. With both eyes viewing, however, the two eyes made circular movements of equal size. In conclusion: the intermittent wearing of anisometric spectacles by this subject was, under normal conditions (binocular viewing), adequately matched by a very versatile degree of asymmetrical adaptation.

## DISCUSSION

The present experiments demonstrate that saccadic eye movements can adapt asymmetrically to the long-term wearing of anisometric spectacles, which confirms and extends work done by Erkelens et al. (1989b). In addition, I found that long-term asymmetrical adaptation was also present in smooth-pursuit eye movements. As a result of asymmetrical adaptation, Hering's law of equal innervation is violated in the sense that these two kinds of (versional) eye movements become unequally large in the two eyes (for a discussion on Hering's law, see Chapter 2). Although Hering's law is also slightly violated in normal subjects, as was demonstrated in Chapter 5, the violations that occur in asymmetrically adapted eye movements can be very striking. I shall now discuss the present results in further detail.

Erkelens et al. (1989b) found in the subject they reported on that the asymmetrical adaptation to his long-term wearing of anisometric spectacles was more complete for vertical saccades than for horizontal saccades. The same authors suggested that this meridional difference might possibly be explained by the fact that the fusional limits for vertical disparities are smaller than for horizontal disparities (Fender and Julesz, 1967; Piantanida, 1986; Erkelens, 1988). Asymmetrical adaptation would then occur up to the level that fixation disparities were reduced to within the fusional limits. In other words, loss of fusion might be the adequate stimulus for asymmetrical adaptation. Therefore, asymmetrical adaptations of saccades would be more complete for the vertical than for the horizontal meridian. However, in my experiments, vertical asymmetrical adaptations

were, for the group as a whole, equally complete as horizontal asymmetrical adaptations, although some idiosyncratic variations existed. The deficits of these asymmetrical adaptations were, for saccades in either meridian, almost always smaller than 0.75 deg during binocular viewing. These vergence-deficits equalled the fixation disparities at the end of the primary saccades during binocular viewing. Fixation disparities virtually always became smaller shortly afterwards due to asymmetrical secondary saccades, and also, for horizontal saccades, due to asymmetrical post-saccadic drift. As a consequence, fixation disparities at the time of saccadic offset, and also very shortly afterwards, were, for horizontal saccades, well within the fusional limits, which can be as large as about 2 deg (Erkelens, 1988). For this reason, and also because I found no better asymmetrical adaptation for vertical saccades than for horizontal saccades, despite narrower fusional limits along the vertical meridian than along the horizontal meridian, loss of fusion appears to be a less likely stimulus for asymmetrical adaptation than fixation disparity per se. In addition, if loss of fusion at saccadic offset were indeed the adequate stimulus for asymmetrical adaptation, the general increase that I observed in the vergence-deficits with the target amplitude, would presumably not have occurred. Instead, a more uniform vergence deficit across the range of target amplitudes would have been more likely. Furthermore, if diplopia at saccadic offset were the adequate stimulus, we would presumably experience double-images very frequently throughout the course of a lifetime, before asymmetrical adaptations to local changes within the oculomotor system, caused by ageing, disease or fatigue, would come about. Therefore, the limits of the stimulus for asymmetrical adaptation should a priori be narrower than the limits of fusion.

Another point of interest is that I found no uniform percentage of asymmetrical adaptation at the various target amplitudes. This shows that asymmetrical adaptation does not result from the resetting of a few simple gain parameters that control the coordination of the two eyes. Such a simple resetting has, however, been put forward as a possible general control strategy for adaptation of the saccadic subsystem (e.g., Deubel, 1986). Erkelens et al. (1989b) have already pointed out, however, that the results of the experiments carried out by Deubel et al., which support such a hypothesis, could have been affected by a flaw in the experimental design. The present results suggest that asymmetrical adaptation occurs on a point-to-point basis in the topology of sensory-motor maps, in such a way that the vergence deficits, or fixation disparities during binocular viewing, remain within narrow limits.

Why is asymmetrical adaptation more complete during binocular viewing than during monocular viewing? An obvious explanation is that, during binocular viewing, both eyes receive direct visual information on the position of the newly selected target and, therefore, accurate motor commands can be computed for each individual eye. With one eye covered, this is obviously not the case. However, if unequally large saccades in the two eyes were programmed solely on direct asymmetrical visual information, saccades in the two eyes would probably not be unequal in size during monocular viewing. My results therefore suggest that the control of asymmetrical coordination of saccades of the two eyes consists of, at least, two components: 1) a fairly steady, hard-programmed interocular coordination, demonstrable during monocular viewing, which is not complete, but forms a basic level of interocular coordination, and which can only be modified slowly and through experience, and 2) a component that is complementary in action to the first one, and that requires direct, binocular visual information for the fine-tuning of accurate coordination of the two eyes. The hard-programmed component would presumably be too robust to meet the requirements of interocular coordination in normal life. One possible reason for this would be that most objects we look at vary both in direction and in distance, thus requiring slight departures from the basic interocular coordination of saccades. The second, fine tuning component would probably have a relatively small range. Therefore, without the complementary action of the first, hard-programmed component, the saccadic size-differences required by the spectacles would be beyond the range of this second, high-precision component. Support for such a limited range of the second component comes from the common experience that when a subject puts on anisometric spectacles for the first time, he will perceive double-images. Only through continued experience will he be able to maintain fusion at all times. Adaptation will only be adequate if the contribution of one component is sufficiently complemented by the other.

Possibly, the interocular coordination of normal, i.e., not asymmetrically adapted, saccades could be under similar, dual component control. As I demonstrated in Chapter 5, even normal saccades become, during monocular viewing, slightly smaller in the covered eye than in the viewing eye. The hard-programmed component would then be responsible for the fairly good interocular coordination during monocular viewing, but it would take the complementary action of the second, accurate component to make

saccades of the right size in each eye during binocular viewing. That the action of the supposed hard-programmed interocular coordination component is based on experience, most likely visual information, is supported by experiments run by Vilis et al. (1985) and Viirre et al. (1987). These authors patched one eye in monkeys for one week and saw that the saccades of the patched eye gradually changed in size (they became either smaller or larger), when compared with saccades of the viewing eye.

Another striking feature of the asymmetrical adaptation of saccades to the wearing of anisometric spectacles is that the degree of adaptation can be very versatile. This was demonstrated by the difference in asymmetrical adaptation in subject PJ either with and without his spectacles on. This difference was not only present during binocular viewing, but also during monocular viewing, which shows that he may change his hard-programmed asymmetrical adaptation very quickly. I do not know whether his hard-programmed asymmetrical adaptation can vary so rapidly between only two, more or less remembered, modalities, or whether it can vary equally rapidly over a wider range to meet any requirement.

Two subjects experienced double-images in the upper oculomotor range when they made saccades, but also when they smoothly pursued the circularly moving target. One possible explanation for this poor asymmetrical adaptation might be that eye movements are normally made more frequently in the lower oculomotor range than in the upper oculomotor range. Therefore, the pressure for adaptation would be smaller in the higher oculomotor range than in the lower oculomotor range. This explanation was also given by Henson and Dharamshi (1982), who found that adaptation of vertical phorias to anisometric spectacles was larger, and also more rapid, in the lower oculomotor range than in the upper oculomotor range. This phenomenon had also been described by Ellerbrock (1948). My two subjects did not experience double-images when they took off their glasses.

The asymmetrical changes in post-saccadic drift were very small and restricted to horizontal saccades. These changes presumably reflect asymmetrical, adaptive resettings of the pulse-step ratios, that characterize the motor commands to the external eye-muscles for the generation of saccades. These very slight asymmetrical changes in post-saccadic drift-velocities contrast with the dramatic changes in post-saccadic drift

associated with palsies of one or more external eye-muscles (Kommerell et al., 1976; Abel et al., 1978; Snow et al., 1985; Optican and Robinson, 1980; Optican et al., 1985). One explanation for this difference might be that my subjects had adapted maximally, so that the pulse and the step of either eye apart were closely matched to each other. In the monkey, large asymmetries in post-saccadic drift, secondary to unilateral tenectomies of external eye-muscles gradually became less when viewing was binocular for several weeks (Snow et al., 1985). It remains to be seen, whether short-term asymmetrical adaptation, to be discussed in the following Chapters, is associated with different asymmetries in post-saccadic drift from long-term asymmetrical adaptations. Another explanation for the differences in post-saccadic drift-asymmetries between my subjects and subjects with unilateral external eye-muscle palsies might be that the sizes of the retinal images in the two eyes were different in my subjects, whereas this was not the case in the subjects having paretic eye-muscles. In addition, the eye-muscles of my subjects were not affected. Therefore, the asymmetrical adaptations required in either condition might result from different adaptive processes, and consequently yield different asymmetries in post-saccadic drift.

Little is known about adaptive processes of smooth-pursuit eye movements (for a review, see Berthoz and Melvill Jones, 1985). Except for one short communication by Horner et al. (1988), asymmetrical adaptations of smooth-pursuit eye movements have, to my knowledge, not been described before. An important feature of smooth-pursuit eye movements is that the movements are relatively slow, which allows continuous visual feedback. In contrast, saccades are not controlled by continuous visual feedback (see Chapter 1). The continuous visual feedback that takes place during smooth-pursuit eye movements may possibly explain why the vergence-deficits that I observed during binocular viewing were smaller when my subjects tracked the slowly moving target than when they made saccades. However, this difference in vergence-deficits can also be partly explained by the fact that saccades usually undershoot their target and are then followed by one or more secondary saccades which in turn may reduce the vergence deficits, present at the offset of the primary saccades. In addition, post-saccadic drift of horizontal saccades also reduced the vergence-deficits.

More importantly, asymmetrical adaptations of smooth-pursuit eye movements were also present when one eye was covered. The vergence-deficits, used as a measure of

asymmetrical adaptation, were similar to those associated with monocularly viewing saccades, and they were also larger than during binocular viewing. I may therefore speculate that asymmetrical adaptation of smooth-pursuit eye movements occurs in a way similar to that for the saccadic subsystem, viz., with a hard-programmed, fairly robust and incomplete component, as well as with a complementary, precise component, that requires direct, binocular visual information. In the present experiments, the hard-wired component was equally powerful with smooth-pursuit eye movements as with saccades, in terms of vergence-deficits. I feel, however, that the number of data are too limited to speculate on the possibility of structures, shared by both eye movement subsystems, that control interocular coordination.

An interesting question is whether the target-positions, as viewed through anisometric spectacles can be mimicked by positions of natural targets, i.e., viewed without such glasses. Along the horizontal meridian this is indeed possible. Objects in a frontoparallel plane, seen through anisometric spectacles, are positioned as if that plane is rotated around a vertical axis. Along the vertical meridian, however, there are no positions of natural targets that could simulate targets as seen through anisometric spectacles, which will now be explained. The position of a natural target will always have the same elevation for either eye. Seen through anisometric spectacles, however, most positions (all tertiary positions and those along the vertical meridian, except for the primary position) of any visual target will have different elevations for either eye. In conclusion, anisometric spectacles present visual targets in positions that cannot be simulated by natural targets.

A drawback of the present experiment was that the lens-prescriptions were very heterogeneous. In the following chapters, which focus on short-term asymmetrical adaptations to anisometric spectacles, I shall therefore study these adaptations more systematically, i.e., with the same spectacles for every subject.

## CHAPTER 7

### SHORT-TERM ASYMMETRICAL ADAPTATION

#### INTRODUCTION

In the previous chapter, I discussed asymmetrical adaptations of saccades, and also of smooth-pursuit eye movements in habitual, or long-term, spectacle-wearers. I shall now examine the adaptations that take place when anisometric spectacles are worn for only several hours by normal subjects. Erkelens et al. (1989b) showed that asymmetrical adaptations of saccadic eye movements to 2 D of anisometropia already take place within about 8 hours. In the present chapter, I shall extend their study by exploring the rate as well as the limits of such short-term adaptations. To that end, I systematically varied both the time of wearing of the spectacles (range: 1 to 6 hours) and their degree of anisometropia. Because an anisometropia of about 5 D is, as a clinical rule of thumb, considered to be the upper limit of what may be tolerated, I adopted some anisometropias that were smaller, but also some that were larger than 5 D. To allow comparison between horizontal and vertical adaptations, I only used spherical lenses. In addition, I shall examine short-term asymmetrical adaptations of smooth-pursuit eye movements.

#### METHODS

##### *Subjects*

Three subjects took part in these experiments. They were between 25 and 28 years old. None of them had any history of ocular or oculomotor pathology. These three subjects had refractive anomalies in both eyes that were corrected by hard contact-lenses. With their own corrections, my subjects had visual acuities of 5/5 or better in either eye. Since binocular vision was regarded as essential for asymmetrical adaptation, all three subjects

were tested on stereoscopic vision (test charts: TNO tests for stereoscopic vision), which proved to be good in either one (thresholds: 60 sec arc or better).

### *Adaptation stimuli*

Subjects were supplied with spectacle-frames that contained only one lens, fitted in front of the right eye. This lens was spherical and its refractive power was -2, -4, -6 or -8 D. In order to maintain the same, good visual acuity with every pair of spectacles, subjects replaced their own right-sided contact-lens by one that countered the refractive power of the spectacle-lens, and, in addition, corrected the subject's own refractive anomaly. The overall effect of this spectacle-lens/contact-lens combination was as follows: the spectacle-lens reduced the size of the retinal image in the right eye, whereas the contact-lens compensated for the blurring the spectacle-lens induced. As I explained earlier (Chapter 6), a contact-lens only minimally affects the size of the retinal image, and, more importantly, it does not call for any changes in the size of eye movements, because it moves along with the eye. The use of this combination required that my subjects were already well habituated to the wearing of hard contact-lenses. Therefore, the number of subjects was rather small. Soft contact-lenses could not be used, because they cannot be worn together with the sensor coils with which I recorded eye movements (see Chapter 3). Before the subjects actually started wearing the spectacles, baseline recordings were made. On another day, they began to wear the anisometric spectacles, beginning with the spectacles having the smallest anisometropia (2 D), for 1 hour continuously. On separate days, the wearing-time of the same spectacles was gradually increased to 2, 4 or 6 hours at a stretch. To reduce any possible carrying over of long-lasting asymmetrical adaptations between successive sessions, the days the spectacles were worn were interleaved by two or more days that no adaptation was required. The same procedure was thereafter followed with spectacles having gradually larger anisotropias (4, 6 or 8 D). This entire conditioning-programme, which consisted of sixteen sessions on which spectacles were worn for a variable amount of time, were spread, for every subject, over more than two months. While wearing the spectacles, the subjects went on with their normal daily activities. To allow a direct comparison with the results of Erkelens et al. (1989b), the three subjects were finally also fitted with one positive lens (+2 D) in front of the right eye for 6 continuous hours.



### *Experimental procedures*

After the completion of each adaptation-period, i.e., the time that the anisometric spectacles were worn, magnetic sensor coils were put onto each of the eyes. To that end, the spectacles had to be taken off temporarily, and care was taken that one eye remained covered at all times, to prevent any symmetrical visual input, that could possibly undo the effects of the spectacle-wearing. Thereafter, the actual experiments were run. The procedures of these were very similar to those described in the previous two chapters and they will now be described in brief. During the trials, the subjects continued to wear the spectacles. The subjects were seated facing the white, toroid screen that provided no stimulus for disjunctive eye movements. Subjects made repetitive gaze-shifts between two, continuously present, bright-red He-Ne laser spots at a comfortable pace, indicated by a sound that beat steadily at a rate of 45/minute. The subjects were asked to carry out the gaze-shifts as accurately as possible. The targets were positioned symmetrically about the straight-ahead position, 10 or 30 deg apart, either horizontally or vertically. At the beginning of each trial, the targets were displayed in their new position, which allowed the subjects to practise if they wanted to. Actual data-collection lasted 12 s for each trial and was started by the subjects themselves when they felt ready for the task. Subjects were asked not to blink during data collection, to avoid the occurrence of associated eye movements (Collewijn et al., 1985). Viewing was binocular, or monocular with either eye. The order of the trials was randomized for every subject. After completing the saccade trials, the subjects tracked a single target that made a uniform, circular movement (diameter of the circle: 30 deg), both during binocular viewing and during monocular viewing with either eye. The recordings were stored on disk. Recordings made of steady fixations of targets with known positions during monocular viewing with either eye, made without the spectacles, enabled us to finely recalibrate and to linearize the recordings and also to express all eye-positions in Helmholtz's coordinates (for details see Chapter 3).

### *Data analysis*

All recordings were analysed by a special computer programme, which computed saccade-size and mean post-saccadic drift-velocity of every saccade, according to standard criteria (as described in Chapter 5). These results were thereafter submitted to another computer programme (SPSS-X) for statistical analysis. The numbers of data were

balanced for the four conditioning-periods, the four degrees of anisometropia, the two meridians, the two target amplitudes and the direction of the saccades. I then calculated the size-differences between concomitant saccades of the two eyes, as well as the vergence-deficits at saccadic offset. Vergence-deficit (see Chapter 6) was defined as the difference between the required difference in saccade-size between the two eyes, as measured from monocular fixations made through the spectacles of targets with known positions, and the actual difference in size of concomitant saccades. Mean values were calculated and the same data were also submitted to a multivariate analysis of variance (MANOVA). To meet the requirements of normal distributions and homogeneous variances, all parameters were logarithmically transformed.

## RESULTS

### *Saccade-size*

Asymmetrical adaptations of saccades occurred in all three subjects. These adaptations were already present after only 1 hour of continuous wearing of any of the four different anisometric spectacles, which varied in anisometropia from 2 to 8 D. Differences in asymmetrical adaptations between subjects were very small. Therefore, only main trends will be discussed. The short-term adaptational asymmetries were manifest during binocular viewing, and also during monocular viewing. Figure 7.1 presents some typical recordings of horizontal saccades, before and after adaptation to only 2 D of anisometropia during 1 hour, made with the right eye covered (i.e., the eye that was required to make the smaller eye movements). In this figure, the right, covered eye made, after conditioning, saccades that were about 1.5 deg smaller than those of the left, viewing eye.

Both the duration of the wearing of the anisometric spectacles and the degree of anisometropia affected the magnitude of the short-term asymmetrical adaptation of saccades. The magnitude of these effects varied, however, also with the target amplitude (10 or 30 deg), the viewing condition (binocular or monocular viewing) and the meridian (horizontal or vertical). I shall now discuss these rather complex adaptational effects in greater detail. In Fig. 7.2 I present mean values of the differences in saccadic size between the two eyes as a function of the wearing-time of the spectacles for every

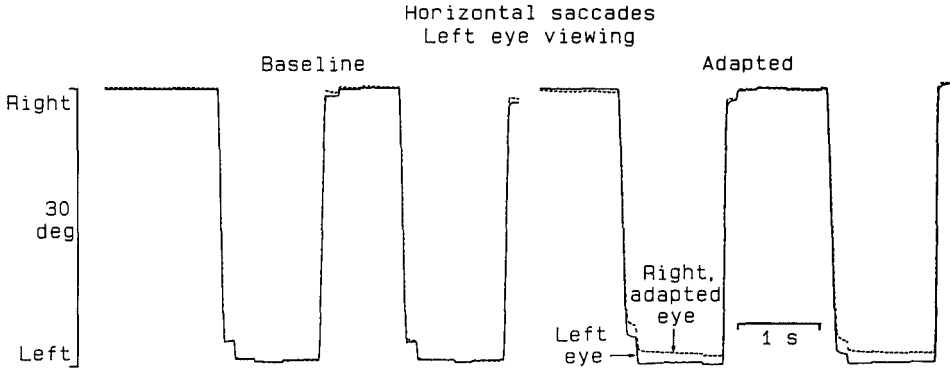


Fig. 7.1 Typical recordings of horizontal saccades of each eye made with the left eye viewing. The left panel shows baseline recordings, and the right panel shows recordings made after 1 hour of adaptation to 2 D of anisometropia. Target amplitude: 30 deg.

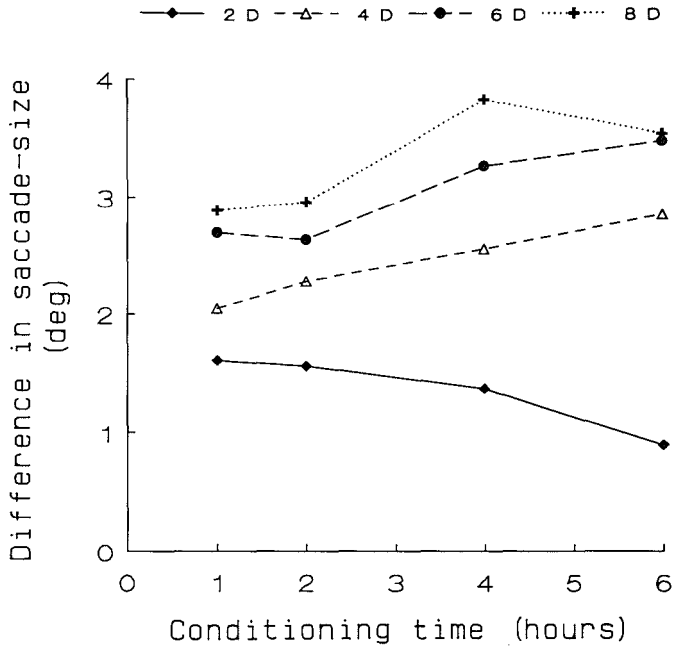


Fig. 7.2 Mean differences in saccadic size between the two eyes, plotted as a function of the conditioning-time, for the four degrees of anisometropia. These data relate to horizontal saccades made during binocular viewing at a target amplitude of 30 deg.

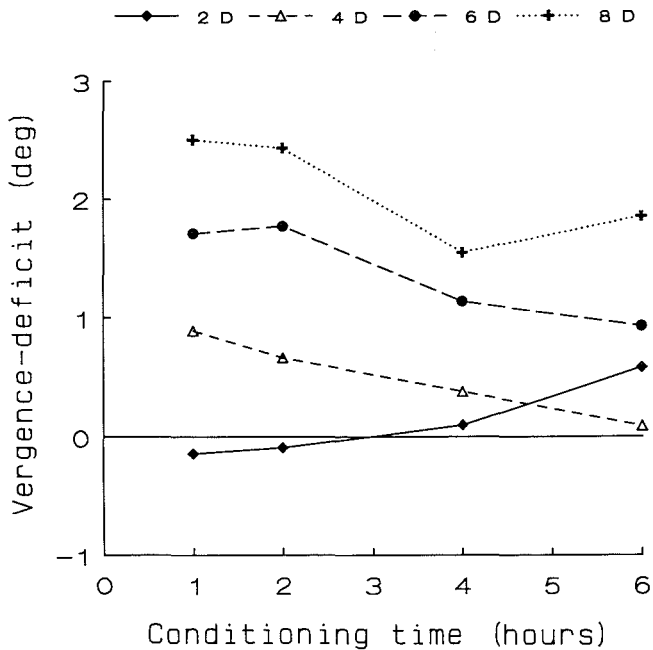


Fig. 7.3 Mean vergence-deficits plotted as a function of the conditioning time. These data relate to the same saccades as in Fig. 7.2.

anisometropia tested. As mean values, averaged for the two target amplitudes, the three viewing conditions and the two meridians would not be very meaningful, the data of this figure relate only to horizontal saccades, made between targets that were positioned 30 deg apart, while viewing was binocular. During monocular viewing and also at the smaller target amplitude (10 deg) the asymmetrical size-changes of horizontal saccades differed only quantitatively, but not qualitatively from these results. The figure shows that the saccadic size-differences between the two eyes increased with the anisometropia of the spectacles ( $F_{3,6} = 8.90$ ;  $P < 0.05$ ). Above 6 D of anisometropia, however, there was no significant rise ( $P > 0.9$ ), which suggests that a critical limit of the sensitivity to asymmetrical adaptation had been reached. After only 1 hour of adaptation, saccades of the two eyes differed in size by about 1.6 deg for the smallest anisometropia (2 D) up to about 2.8 deg for the two largest anisometropias (6 D and 8 D). With prolonged wearing of the spectacles, the differences in saccadic size between the two eyes generally increased. This increase occurred, compared with the first hour of adaptation, rather

slowly. It averaged about 0.7 deg over 5 hours ( $F_{3,6} = 7.56$ ;  $P < 0.05$ ). However, with the smallest anisometropia (2 D), the difference in magnitude between saccades of the two eyes, did not increase with prolonged wearing. Instead, this difference gradually went down by about 0.7 deg, becoming approximately 0.9 deg after 6 hours of adaptation ( $F_{9,18} = 4.37$ ;  $P < 0.005$ ).

To examine the efficacy of these short-term adaptations, I have plotted the mean vergence-deficits at saccadic offset as a function of the conditioning-time for the various anisometropias in Fig. 7.3. These data relate to the same, horizontal saccades as in Fig. 7.2 (30 deg saccades, binocular viewing). Vergence-deficits went up with larger anisometropias ( $F_{3,6} = 97.2$ ;  $P < 0.0005$ ). At the smallest anisometropia (2 D), they were, on average, only about 0.1 deg. With the largest anisometropia (8 D) vergence-deficits were much larger: about 2.5 deg after 1 hour of adaptation (for horizontal, 30 deg saccades during binocular viewing). By comparing Fig. 7.2 with Fig. 7.3, one can conclude that, in spite of the fact that the difference in saccadic size between the two eyes generally increased with the anisometropia, these asymmetrical adaptations also fell increasingly short at larger anisometropias. As a consequence, the average degree of asymmetrical adaptation of horizontal saccades made during binocular viewing went down from about 90% for the 2 D anisometropia to about 60% for the 8 D anisometropia.

With 4 D of anisometropia, adaptation of horizontal saccades (binocular viewing) was almost complete after only 6 hours of adaptation (Fig. 7.3). With 6 D of anisometropia, the asymmetrical adaptation occurred at about the same rate as with 4 D of anisometropia, but it was still not complete after 6 hours. As this duration of adaptation is fairly short, the asymmetrical adaptation to 6 D of anisometropia would presumably have improved with prolonged wearing of the glasses. It is less clear what the time-course of adaptation beyond 6 hours of conditioning to 8 D of anisometropia would be like, because all three subjects were better adapted after 4 hours than after 6 hours of adaptation. As was already pointed out in relation to Fig. 7.2, the magnitude of asymmetrical adaptation surprisingly went down with prolonged wearing of 2 D anisotropic spectacles. This decline in adaptational asymmetry of horizontal saccades occurred in all three subjects.

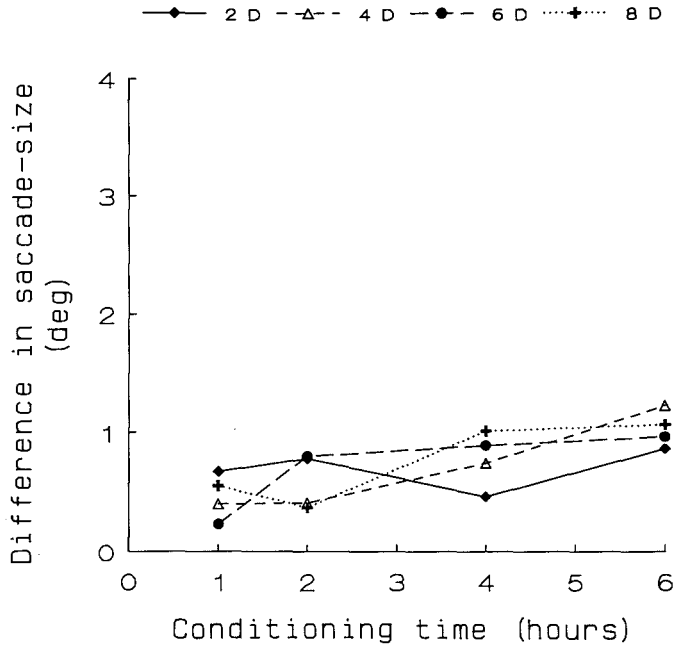


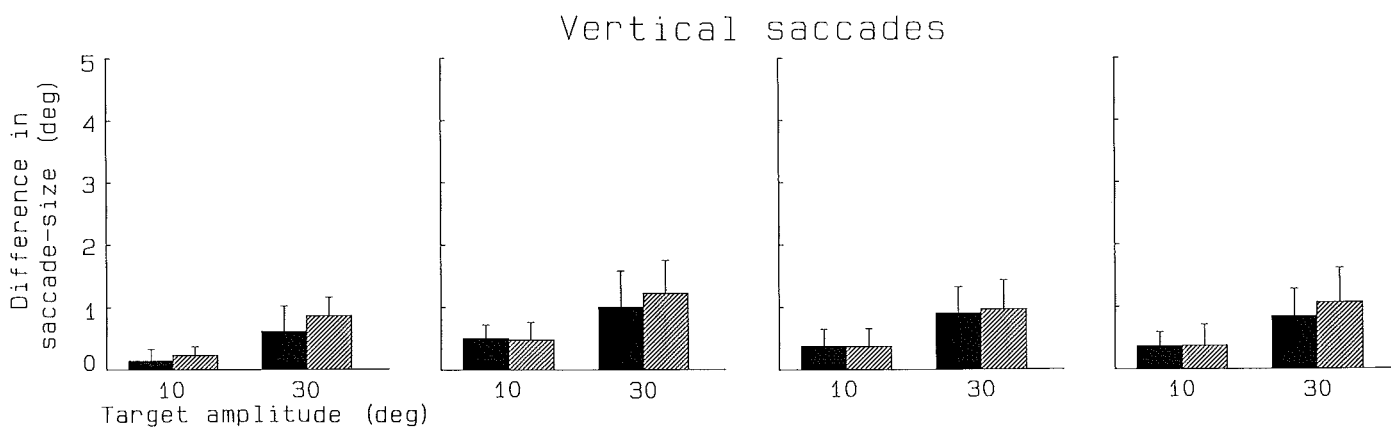
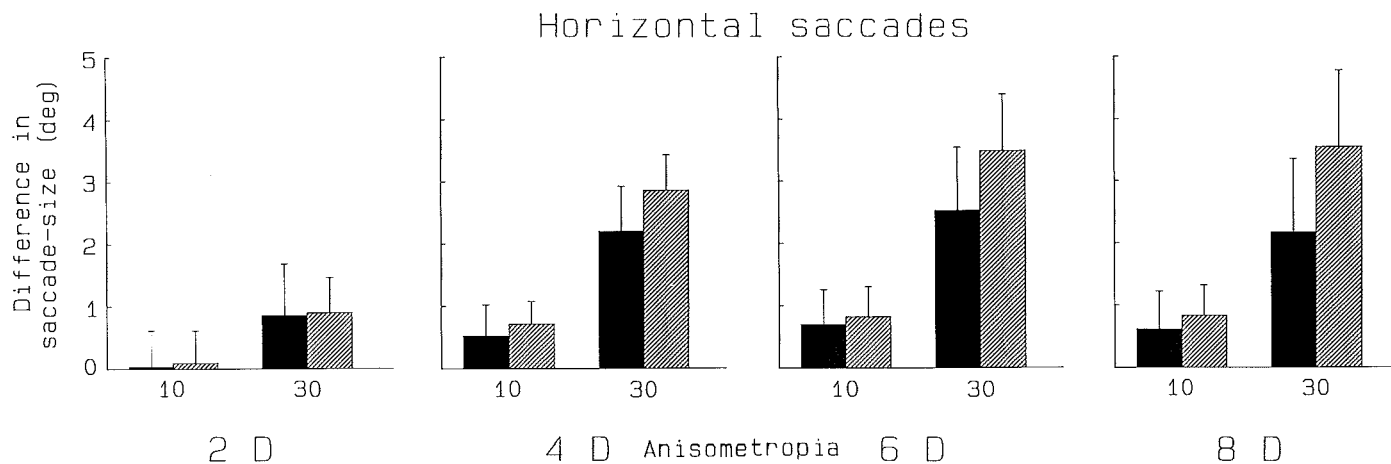
Fig. 7.4 Mean differences in size between vertical saccades of the two eyes, plotted as in Fig. 7.2. Viewing was binocular and the target amplitude equalled 30 deg.

For vertical saccades, differential changes in size were two- to four-fold smaller than for horizontal saccades ( $F_{1,2} = 46.7$ ;  $P < 0.05$ ). To quantify the vertical adaptations, I have plotted in Fig. 7.4 the mean differences in saccadic size between the two eyes for vertical saccades, as a function of the spectacle wearing-time for the four various anisometropias. Like Fig. 7.2, Fig. 7.4 relates to binocular viewing and a 30 deg target amplitude. Changes in the yoking of vertical saccades averaged about 0.5 deg after 1 hour of adaptation. Unlike with horizontal saccades, these changes did not increase with the anisometropia. With continued conditioning, however, the differences in size between saccades of the two eyes became slightly larger and amounted to about 1.0 deg in 5 additional hours. This increase by about 0.5 deg was about as large as with horizontal adaptations. This adaptational increase in asymmetry occurred also with the 2 D anisometropia, which contrasts with the decline in asymmetry that was observed in horizontal saccades. As a result of the poorer adaptation of vertical saccades, compared to those of horizontal saccades, the vergence-deficits at saccadic offset of vertical

saccades were relatively large. On average, they were about 2.5 deg larger than with horizontal saccades, and sometimes as large as 5 deg.

Although I did not systematically examine fusion, all three subjects frequently experienced vertical double-images, which were farther apart with larger anisometropias, notably in the upper oculomotor field. With anisometropias of 4 D and smaller, fusion was usually complete after 6 hours of conditioning in all eye-positions.

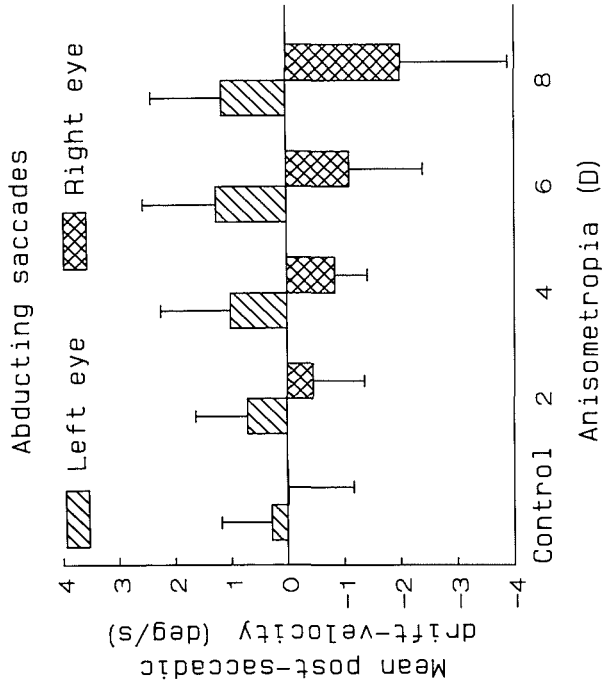
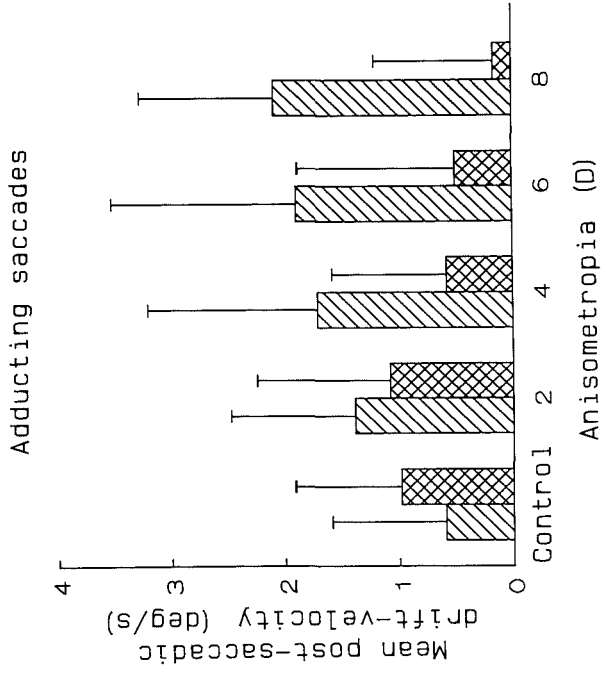
Virtually the same trends as were described above existed, for each meridian and for each subject, during monocular viewing, and also for the smaller target amplitude of 10 deg. However, the magnitudes of these adaptational changes were significantly different, as will now be discussed in more detail. Figure 7.5 presents mean differences in saccadic size between the two eyes for the two various target amplitudes after 6 hours of conditioning. I have also distinguished between the four degrees of anisometropia, the two meridians and the viewing conditions (i.e., binocular viewing or monocular viewing with either eye). This figure shows that, during binocular viewing, the differences in saccadic size between the two eyes were generally larger than during monocular viewing ( $F_{2,4} = 14.8$ ;  $P < 0.05$ ). Furthermore, this effect of the viewing condition was larger for horizontal saccades than for vertical saccades ( $F_{2,4} = 7.18$ ;  $P < 0.05$ ). For horizontal saccades, made at a target amplitude of 30 deg, the viewing condition affected the yoking of saccades by as much as about 0.8 deg, as opposed to about 0.2 deg for vertical saccades. However, with 2 D of anisometropia the difference in size between horizontal saccades of the two eyes was, after 6 hours of adaptation, equally large in either viewing condition. In fact, the gradual decrease in saccadic asymmetry with prolonged adaptation to 2 D of anisometropia, following an initially large asymmetry after 1 hour of conditioning (Figs 7.2 and 7.3), was also present in monocular viewing. It is also clear from Fig. 7.5 that the difference in saccadic size between the two eyes was, not surprisingly, larger at the larger target amplitude than at the smaller target amplitude ( $F_{1,2} = 126.1$ ;  $P < 0.01$ ). This increase was four- to five-fold for horizontal saccades and about two-fold for vertical saccades. Compared with the exactly three-fold increase that was required by the spectacles, it is clear that the degree of adaptation was not a fixed percentage of these requirements.





All these results show that short-term asymmetrical adaptation of vertical saccades was less complete than for horizontal saccades, which contrasts with results by Erkelens et al. (1989b), who found that such adaptation was either equally complete in the two meridians or more complete for vertical saccades than for horizontal saccades. The main difference between their study and ours was that they used a positive spectacle-lens, instead of the negative lenses I used. I therefore repeated the experiment by Erkelens et al. by having my subjects also wear, for 6 continuous hours, a positive, spherical lens with the same refractive power (+2 D) in front of the right eye. With the exception that eye movements of the right eye now were larger than those of the left eye, there was no significant difference in asymmetrical adaptation, compared to when the subjects had worn -2 D for 6 continuous hours.

**Fig. 7.5** Mean differences in saccadic size between the two eyes (+ SD) for horizontal and vertical saccades after 6 hours of conditioning. Distinctions are made for the two target amplitudes, the two viewing conditions (left eye viewing and right eye viewing pooled) and the four degrees of anisometropia.



### *Post-saccadic drift*

Post-saccadic drift was also differentially adapted for either eye ( $P < 0.05$ ). When the right eye, i.e., the eye provided with the negative spectacle lenses, made abducting, rightward saccades, backward post-saccadic drift ensued which increased in velocity with the anisometropia (Fig. 7.6). As an example, baseline mean velocities of this backward drift were about 0.1 deg/s, whereas they became as high as about 2 deg/s with 8 D of anisometropia. The concomitant, adducting saccades of the fellow eye also showed increasingly higher post-saccadic drift-velocities at larger anisotropias. These velocities could become as high as about 2.1 deg/s (baseline: 0.6 deg/s). However, this drift was directed onward, as opposed to the backward post-saccadic drift of the right eye. Therefore, the asymmetrically adapted post-saccadic drift for these, rightward, saccades, reduced the vergence-deficits existing at saccadic offset. Likewise, post-saccadic drift of leftward saccades was also asymmetrically adapted, to have the same effect of reducing the vergence-deficits (Fig. 7.6). These results confirm similar findings by Erkelens et al. (1989b). Post-saccadic drift of vertical saccades proved to be not significantly affected by the short-term wearing of anisometric spectacles.

**Fig. 7.6** Mean post-saccadic drift-velocities (+ SD) of abducting saccades (left panel) and adducting saccades (right panel) for the various degrees of anisometropia. Positive drift-values indicate onward drift; negative drift-values indicate backward drift.

Binocular viewing      Left eye viewing

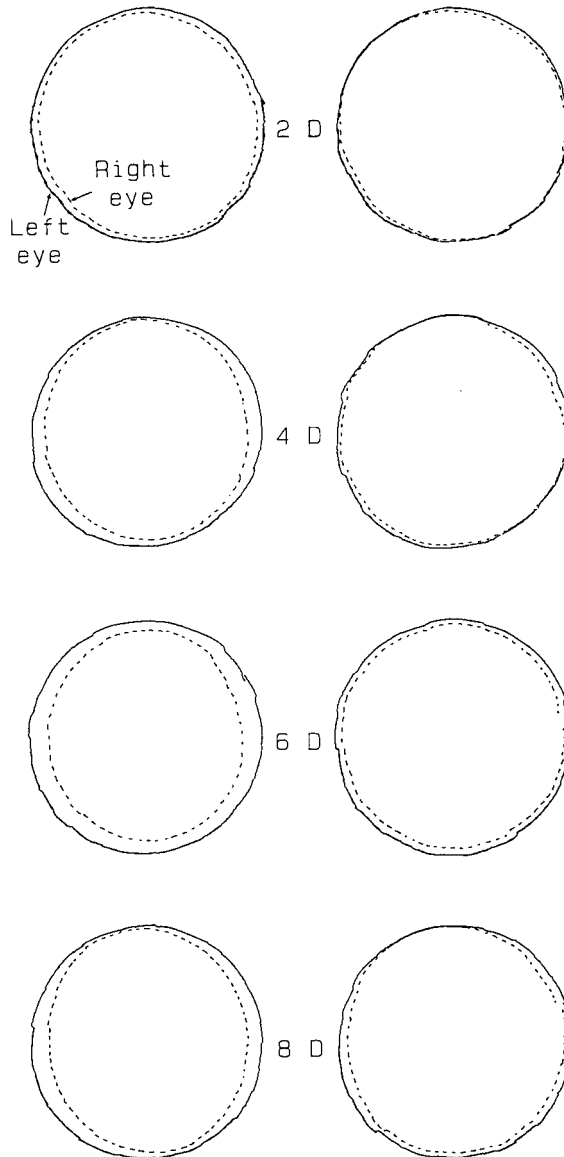


Fig. 7.7 Typical recordings of both eyes made during the smooth-pursuit task after 6 hours of adaptation to the four various degrees of anisometropia. The recordings displayed in the left panels were made during binocular viewing; the right panels relate to monocular viewing with the left eye.

### *Smooth-pursuit*

As with the saccades, smooth-pursuit eye movements became unequally large on either side after adaptation to the anisometric spectacles. Again, the asymmetries were larger during binocular viewing than during monocular viewing. As with saccades, the adaptations were more complete along the horizontal meridian than along the vertical one. All these effects are illustrated in Fig. 7.7, which displays typical recordings under various conditions. Asymmetries generally became larger with increasing anisometropias, although this increase appeared to have reached its maximum at an anisometropia of 6 D. Prolonged wearing of the spectacles only slightly affected the difference in size between the movements of the two eyes. Along the horizontal meridian, the largest increase in adaptive asymmetry was, just as with saccades, achieved within only 1 hour of adaptation.

### *Perception*

A remarkable subjective phenomenon occurred in every subject. After wearing the anisometric glasses for several hours, the visual world became distorted in such a way that all objects on the right side of the visual field appeared smaller, and at the same time, closer by. This illusion, associated with anisometric spectacles, was also described by Ogle (1962). When the subjects took off their spectacles, after completion of the measurements, they occasionally observed double-images, notably during downward or upward gaze. These effects were transient and usually disappeared within about 3 minutes of normal binocular viewing. All subjects were under the impression that it took more time to adapt to the spectacles, than to readapt back to normal. No recordings of eye movements were made during readaptation to sustain this subjective impression with objective recordings.

## DISCUSSION

The present experiments demonstrate that saccades, and also smooth-pursuit eye movements, may adapt asymmetrically to anisometric spectacles in a very short period of time. Large asymmetries occurred in as little as 1 hour. Such very short-term adaptations have, to my knowledge, not been reported before. The remarkable speed and magnitude of these very short-term adaptations suggest that the oculomotor system may normally also adapt rapidly and to an adequate extent to changes that take place as a result of growth, ageing, disease or fatigue. This flexibility of the oculomotor system, which presumably also applies somewhat similarly to other sensori-motor control systems, suggests that many such changes remain concealed.

A remarkable feature of horizontal short-term adaptations was, that the largest change in adaptive asymmetries had developed within only 1 hour of conditioning. Thereafter, adaptations continued relatively slowly. Time-courses of adaptational changes of the saccadic subsystem have been reported earlier. On a larger time-scale than in the present experiments, Abel et al. (1978) closely followed the adaptational changes in saccade-size in a patient who had suddenly developed a unilateral medial rectus paresis. By covering the normal eye for about 1 week, they observed that the saccades of the paretic eye gradually became larger in the appropriate direction. The largest change occurred during the first day. On the days that followed, adaptive changes were considerably smaller. They fitted an exponential curve to the time-course of these adaptive changes. The time constant they reported was 0.85 days. Deubel et al. (1986) and Deubel (1987) had subjects, and also monkeys, track a target that jumped. During the execution of the saccade, the target made a smaller, second jump, either consistently in the same direction, or, on different occasions, consistently in the opposite direction as the first step. They observed that the size of the primary saccades adapted adequately (i.e., became larger or smaller, depending on whether intra-saccadic target-displacements had been onward or backward, respectively) in as little as a few hundred trials. Again, the rate of these adaptations roughly followed an exponential time-course, being fastest at the beginning of the experiments. Although the experiments of Abel et al. (1978), Deubel et al. (1986) and Deubel (1987) related only to symmetrical adaptations of saccades, my present results suggest that somewhat similar time-courses also apply to asymmetrical adaptations. The rate of asymmetrical adaptation during the first hour of

conditioning remains unclear. To elucidate this point, saccades would have to be recorded from the moment that asymmetrical adaptive changes were called for. Erkelens et al. (1989b) recorded saccades of both eyes, while trying to bring about asymmetrical adaptations of saccades, by having subjects repetitively make saccades for 30 minutes between the same, stationary targets. The positions of these targets required that the saccades were not equally large in the two eyes (the gaze-changes entailed both changes in version and in vergence). In this condition, in which no anisometric spectacles were worn, no adaptive changes occurred. Presumably, the stimulus was either not appropriate, or not powerful enough to induce asymmetrical adaptations. In addition, failure to induce asymmetrical adaptation possibly occurred, because in their experimental design, the two targets did not fully resemble two similar targets in the frontoparallel plane, as viewed through anisometric spectacles. I shall mention only a few differences, which may possibly have affected their results. First of all, in their experiment, one target was closer than the other, thereby containing a stimulus for accommodation. Secondly, the closer target presumably appeared brighter than the more distant one. Thirdly, if the positions of the targets had an elevation (either upward or downward) with respect to the positions of the eyes, those target-positions would not resemble those of elevated targets viewed through anisometric spectacles, because a natural target has the same elevation for both eyes, whereas a target viewed through anisometric spectacles has different elevations for each eye (see Chapter 6). Finally, if anything else but the targets were visible in the experiment by Erkelens et al. (1989b), it might have provided conflicting stimuli, thereby preventing asymmetrical adaptation to develop.

In contrast with the horizontal asymmetrical adaptations, which reached a substantial magnitude in only 1 hour of conditioning, thereby displaying the somewhat exponential time-course mentioned above, vertical asymmetrical adaptations were comparatively small, despite equally large pressures for such adaptation along either meridian. Due to the variability of my data it remains inconclusive whether the vertical adaptations also followed pseudo-exponential time-courses. Insight into the various time-courses could possibly provide helpful information in solving the question whether adaptations along either meridian were fundamentally different or not.

Another important meridional difference in asymmetrical adaptation deserves attention. The present experiments show that the rate and the degree of these short-term adaptations are not uniform for every meridian. In my subjects, the most predominant adaptive changes occurred along the horizontal meridian. However, the investigations of short-term asymmetrical adaptations by Erkelens et al. (1989b), showed larger changes along the vertical meridian than along the horizontal one. I ruled out the possibility that this discrepancy could be due to the different kind of spectacle-lens they used. Therefore, it is most likely that idiosyncrasies underly the conflicting outcomes of these two studies. Consequently, one has to be cautious in drawing far-reaching conclusions from the differences in adaptation between the two meridians. Erkelens et al. proposed that the adequate stimulus for asymmetrical adaptations could be related to loss of fusion. They reasoned that, as the fusional limits for vertical disparities are smaller than for horizontal disparities, the pressure for asymmetrical adaptation would be larger for vertical saccades than for horizontal saccades. This matched their observation that vertical adaptations were indeed more complete than horizontal adaptations. However, my present results, and also those of Chapter 6 do not support the general validity of this conclusion. Therefore, loss of fusion does not appear to be the adequate stimulus for asymmetrical adaptation. No matter what the adequate stimulus may be, it is clear that the completeness of asymmetrical adaptation (see Chapter 6), as well as the speed of its development (this chapter), may vary for either meridian. These variations appear to be idiosyncratic. Whether the variations in asymmetrical adaptations are due to variations at an input level (i.e., variability in sensitivity) or at an output level (motor-variability) remains unclear. In any case, the asymmetrical adaptations are not uniform for either meridian. Therefore, it appears likely that each meridian can be adapted selectively. This matter will be dealt with in the following two chapters.

During conditioning, adaptive changes also appear to take place at an input-level. I observed that, with 2 D of anisometropia, differences in saccadic size between the two eyes, after an initial rise following 1 hour of spectacle-wearing, went down with prolonged wearing in all subjects (for horizontal saccades). This suggests that the sensitivity for the stimulus that drives asymmetrical adaptation decreased gradually with time. With larger anisometropias, I did not observe any reduction of the asymmetry that had first developed. Because asymmetrical adaptations were, however, far from complete with these larger anisometropias, as opposed to the almost perfect adaptation that had



been achieved in 1 hour with the 2 D anisometropia, it appears that such reduction in sensitivity may only occur when a critical, high degree of asymmetrical motor-adaptation has been reached. Possibly, this fall in the sensitivity to the stimulus that drives asymmetrical adaptation, is paralleled by adaptive changes at a sensory level, i.e., at a level where the two foveal images are fused. Although such adaptive changes at a sensory level are somewhat speculative, they would explain why many habitual spectacle-wearers (Chapter 6) were also only partly adapted.

I also observed short-term asymmetrical adaptations of post-saccadic drift, which confirm somewhat similar findings by Erkelens et al. (1989b). Asymmetrical adaptations of post-saccadic drift, secondary to unilateral tenectomies of external eye-muscles have also been reported in monkey (Snow et al., 1985). Post-saccadic drift of smaller saccades usually has a slightly lower mean-velocity than the drift that follows larger saccades (Chapter 5). Therefore, nonconjugate post-saccadic drift could, in principle, merely be an epiphenomenon of the smaller saccades, that are made after asymmetrical adaptation to anisometropic spectacles. In that case, the change in yoking would only be characterized by a small reduction in mean drift-velocities of the eye that made the smaller saccades. Because I observed that post-saccadic drift had not simply become slower in the eye that made the smaller saccades, but, instead had changed in the direction appropriate for adaptation, I conclude that the change in yoking of the two eyes during post-saccadic drift was truly adaptive, and not just an epiphenomenon. It is known that, in monkey, post-saccadic drift may adapt independently of saccades (Optican and Miles, 1985). These results suggest that adaptive motor-changes occur at various levels.

Smooth-pursuit eye movements also adapted asymmetrically in a short period of time. In fact, they closely followed the asymmetrical adaptations of saccades. This brings up the question whether these two very different kinds of eye movements, and possibly also other eye movements, are controlled, as far as the yoking of the eyes is concerned, by the same pre-motor circuits. The present results cannot answer this question conclusively, because my subjects carried out their normal daily activities during the conditioning periods, and therefore received plenty of adaptational stimuli for either type of eye movement. Only by not making one of the two kinds of eye-movements during the adaptation-period, could one possibly find out whether these two oculomotor subsystems share a set of pre-motor circuits that control the yoking of the two eyes. An appropriate

experimental design would, however, be highly artificial, and might therefore yield meaningless results.

At present, there is little known about adaptations of smooth-pursuit eye movements (for a review, see Berthoz and Melvill Jones, 1985). The present results confirm those of Horner et al. (1988), who found asymmetrical vertical smooth-pursuit eye movements after 2 hours of adaptation to aniseikonia. Optican et al. (1985) studied smooth-pursuit eye movements in patients with unilateral eye-muscle palsies. However, they confined their observations to the adaptive processes that occurred after patching one eye. As far as other eye movements are concerned, asymmetrical adaptations of the vestibulo-ocular reflex have been reported in monkey after external eye-muscles had been unilaterally severed (Snow et al., 1985). There is some evidence that, in man, asymmetrical adaptation of the vestibulo-ocular reflex may develop to aniseikonia within 24 hours (Collewijn et al., 1983; Schor et al., 1988).

## CHAPTER 8

# MERIDIAN-SPECIFIC ASYMMETRICAL ADAPTATION OF HORIZONTAL AND VERTICAL SACCADES

### INTRODUCTION

In the previous two chapters, I demonstrated asymmetrical adaptations of saccades, and also of smooth-pursuit eye movements, to the wearing of anisometropic spectacles. I observed that these adaptations differed in magnitude and rate for the horizontal and the vertical meridian. Those differences suggest that the adaptational processes which take place in one meridian may be independent of those in the other, orthogonal meridian. Such an independence could possibly enhance the specificity of the adaptive properties of the oculomotor system. In general, a capacity to adapt very specifically to certain changes within the oculomotor system would presumably be very important to protect against any loss in the overall quality of oculomotor control, that could result from such changes. In the present chapter, I shall examine whether asymmetrical adaptation of saccades, and also of smooth-pursuit eye movements may take place in one meridian only (either horizontal or vertical), without affecting such eye movements in the orthogonal meridian.

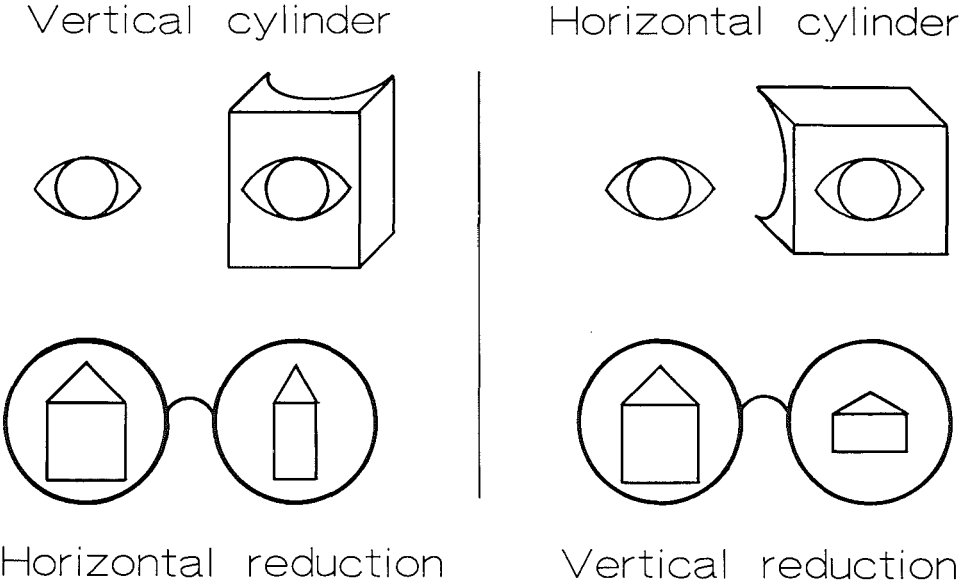
### METHODS

#### *Subjects*

The same nine subjects that took part in the baseline-experiments described in Chapter 5 participated in the current experiments. They had no history of ocular or oculomotor pathology, and their visual acuities were good in either eye. Normal binocular function (in particular stereopsis), assumed to be essential to successful asymmetrical adaptation, was also present in each subject.

*Conditioning*

All subjects were supplied with anisometric spectacles that contained a plano-cylindrical spectacle-lens (-3 D) in front of the right eye. The effect on the size of the retinal image of such a cylindrical lens is illustrated in Fig. 8.1. This figure shows that, with the lens-axis positioned vertically, the visual image is reduced along the horizontal meridian only, virtually not affecting the size along its vertical meridian. When the lens is rotated by 90 deg (i.e., with its axis positioned horizontally), only the vertical meridian is affected in size. The left eye was not supplied with a lens.



**Fig. 8.1** Schema of the effects of the cylindrical lenses and their axis-positions on the size of the visual image (cf. with Fig. 6.1).

The subjects wore these anisometric spectacles, with the axis of the right lens positioned horizontally on one day and vertically on another day, for 7 continuous hours. During this adaptation-period, the subjects carried out their normal daily activities. At the end of the adaptation-period, I ran the actual measurements.

### *Experimental procedures*

During the actual measurements, the subjects wore the anisometric spectacles. The experimental design was similar to the one described in Chapter 5. In short, subjects made repetitive saccades between stationary targets that were projected symmetrically around the straight-ahead position, onto a white, iso-vergence surface (discussed in Chapter 3). The target amplitudes were 5, 10, 20 or 30 deg, both along the horizontal and along the vertical meridian. The saccades were made to a sound beating at a comfortable pace of 45/minute. Data collection lasted 12 s for every trial, initiated by the subjects themselves by pressing a button. The order of the trials was randomized for every subject. Viewing was either binocular or monocular with either eye. Subjects were requested to refrain from blinking, in order to prevent the occurrence of associated eye movements (Collewijn et al., 1985). Following the saccade-experiments, the subjects tracked a single target that moved along the iso-vergence screen in a circle at a slow, regular velocity (about 11 deg/s). Again, viewing was binocular or monocular with either eye. During all these measurements, the head was stabilized by means of a forehead- and chin-support. At the end of all trials, I had the subjects monocularly fixate targets with known positions by the right eye, viewing through the spectacles, to measure the target amplitudes for that eye. By subtracting these target amplitudes from the actual target amplitudes, I calculated, for each subject and for each meridian the differences in saccade-size between the two eyes that were actually required by the spectacles. The required size-differences varied slightly between subjects (range: 5 - 8 % of the nominal target amplitude). I attribute this variation largely to variations in the distance between the spectacle-lens and the eye (for a discussion on the effect of this distance on the size of the visual image, please refer to Chapter 6). Monocular fixations made by each of the two eyes apart without lenses were also carried out as part of the standard calibration-procedures described in Chapter 3.

### *Data-acquisition and data-analysis*

Eye movements were recorded binocularly by means of search coils. When the spectacles were taken off to place the coils onto the eyes, care was taken that one eye remained covered at all times, to prevent any symmetrical visual input, that might undo the effects of adaptation. The recordings were stored on disk. Saccades were thereafter analysed according to standard criteria by a computer-programme, which calculated the size and

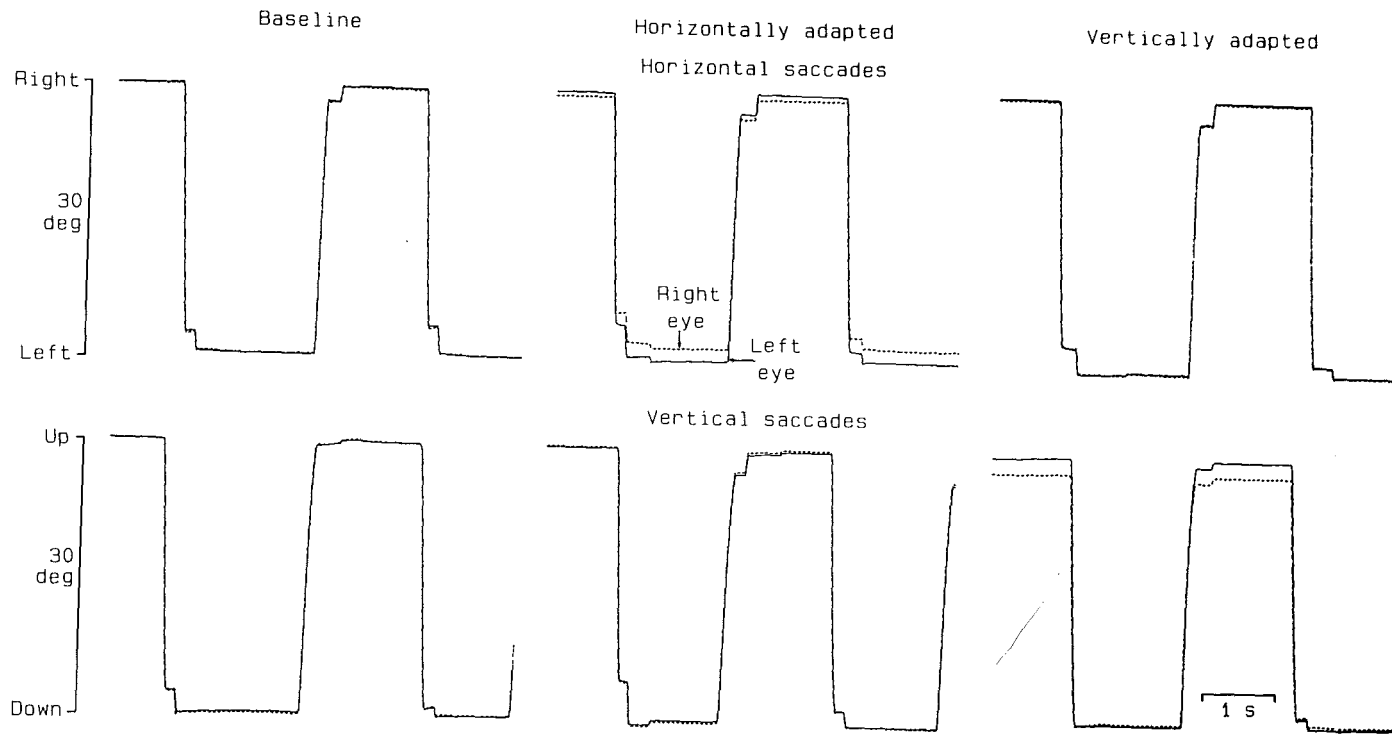
the direction of each primary saccade, as well as the mean post-saccadic drift-velocity. As discussed in Chapter 6, slight displacements of the spectacles on the head were likely to occur during the running of the experiments. Such displacements would affect the positions of the targets as seen by the right eye. I therefore refrained from determining absolute target positions for that eye. Another computer-programme (SPSS-X) was used to carry out statistics on these data. Baseline-data were obtained from the measurements described in Chapter 5. Statistical testing consisted of a multivariate analysis of variance (MANOVA) (for further details, see Chapter 7).

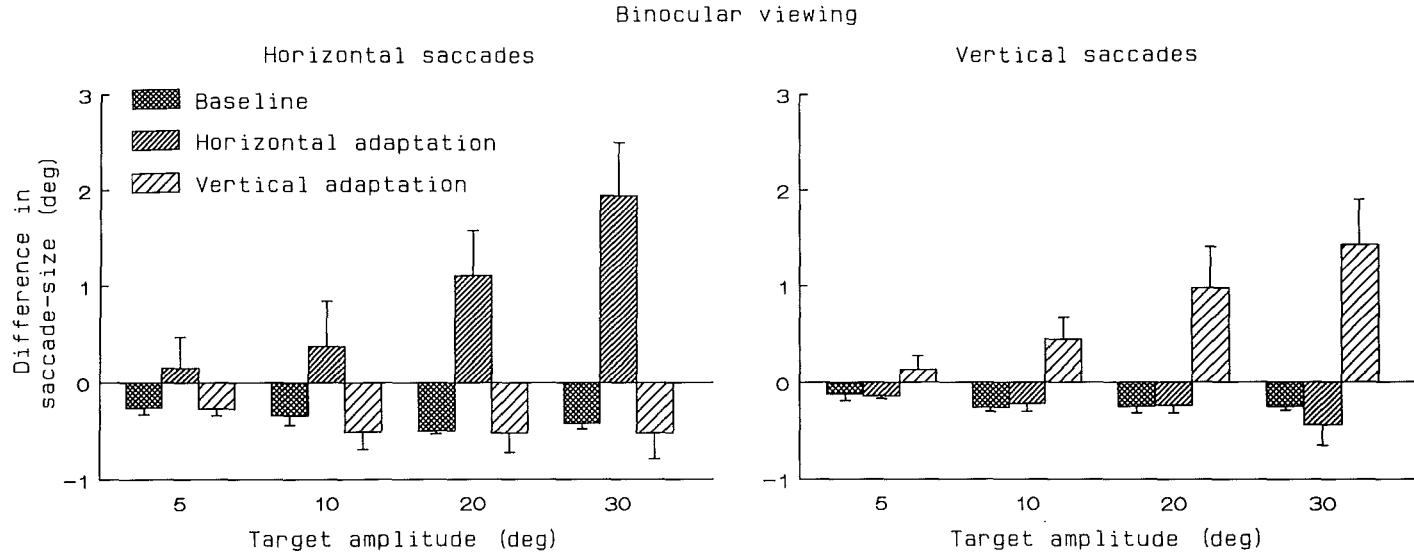
## RESULTS

### *Saccade-size*

The saccades of all subjects had adapted asymmetrically during the 7 hours of conditioning to the anisotropic spectacles described above. These asymmetries were highly meridian-specific ( $F_{2,16} = 314.3$  ;  $P < 0.0001$ ), in accordance with the requirements of the spectacles. Typical recordings of one subject, which illustrate these specific adaptations for either meridian, are shown in Fig. 8.2. The left panel displays binocular recordings of horizontal and vertical saccades made before adaptation. In the middle panel, asymmetrical adaptation had occurred along the horizontal meridian. Horizontal saccades of the right, adapted eye, were in this case about 1.9 deg smaller than those of the left eye (target amplitude: 30 deg). The conjugacy of the vertical saccades, however, was virtually unchanged. When this subject wore, on another day, spectacles with the same lens in front of the right eye, with the lens-axis rotated by 90 deg, only vertical saccades became asymmetrically adapted to about the same degree as the horizontal adaptation had been. The recordings of Fig. 8.2 were made during binocular viewing. With one eye covered, the same, highly meridian-specific asymmetrical adaptations were present, although the differences in saccade-size between the two eyes were somewhat smaller.

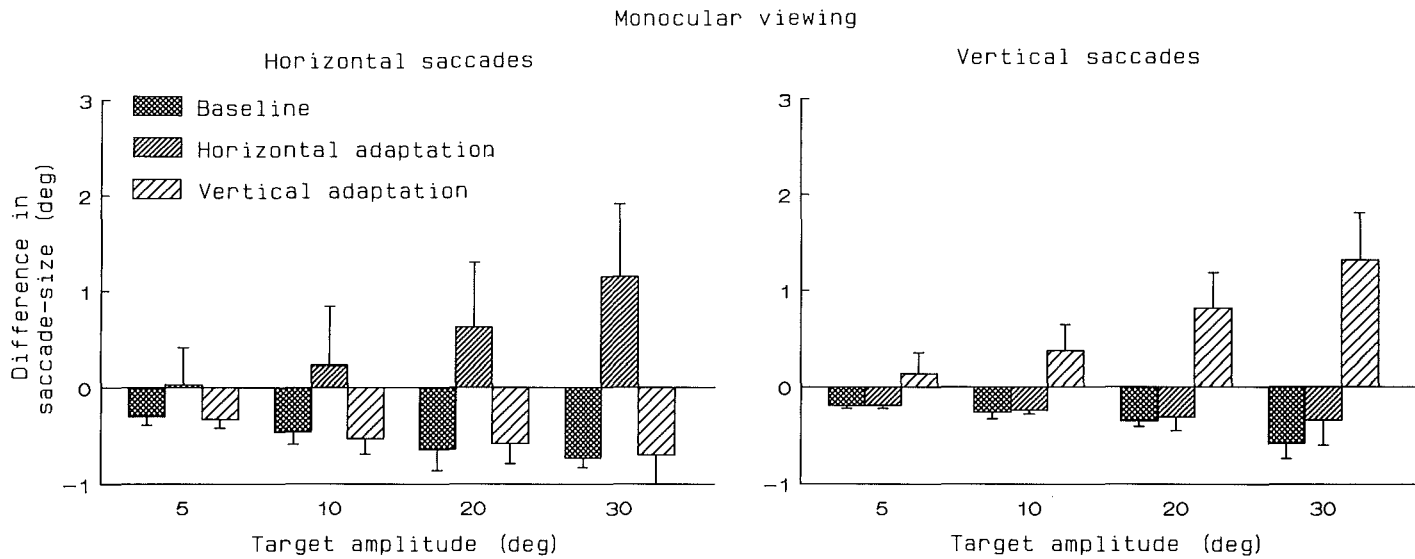
**Fig. 8.2** Typical recordings of horizontal and vertical saccades of the same subject, made during binocular viewing. Left panel: baseline recordings; middle panel: horizontal adaptation; right panel: vertical adaptation.





**Fig. 8.3** Mean differences in saccade-size between the two eyes, expressed in deg (+SD), for horizontal saccades (left panel) and vertical saccades (right panel). Binocular viewing. For comparison, baseline values have been added.

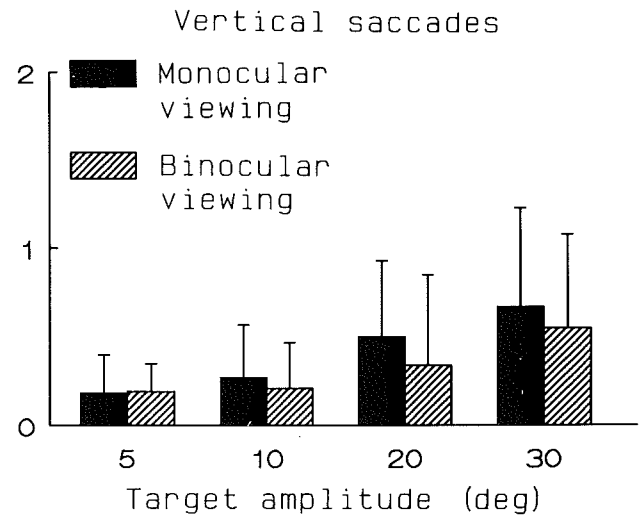
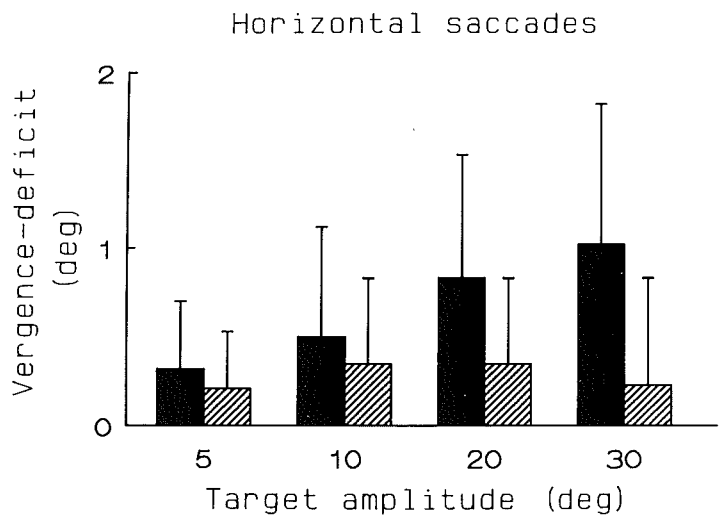




**Fig. 8.4** Same as Fig. 8.3, for monocular viewing with either eye.

To quantify the magnitude of these asymmetrical adaptations, and also to indicate their meridian-specificity, I present mean differences in saccade-size between the two eyes for horizontal and for vertical saccades in Figs 8.3 and 8.4 (Fig. 8.3 relates to binocular viewing and Fig. 8.4 represents data from the monocular viewing conditions). For comparison, baseline values have also been added. Both figures show clearly that adaptational asymmetries occurred over the full range of target amplitudes (5 to 30 deg) in the appropriate meridian only; the degree of yoking in the orthogonal meridian was, after adaptation, essentially the same as before adaptation. The magnitude of the adaptive changes in vergence were, for the saccades made during binocular viewing, on the order of 4% to 7% of the target amplitude, amounting to up to about 2 deg for the largest target amplitude (30 deg). Note that these changes in vergence resulted only from the effects of the anisometric spectacles, and not from the target vergence. For the smallest target amplitude, changes in the degree of yoking were as little as about 15 min arc. All these adaptational size-asymmetries were, on average, about as large for horizontal saccades as for vertical saccades. However, some subjects were better adapted along one meridian (either horizontal or vertical) than along the orthogonal one. These idiosyncrasies varied also with the target amplitudes. When one eye was covered, the asymmetries were, on average, 30% smaller, but, more importantly to the present context, they were equally meridian-specific as during binocular viewing (cf. Fig. 8.3 with Fig. 8.4). This indicates that the meridian-specificity was really hard-programmed, and did not result from direct visual information obtained from both eyes shortly before saccadic onset. The degree of yoking was, on average, the same for monocular viewing with the left eye as for monocular viewing with the right eye. I have, for that reason, pooled the data of the two monocular viewing conditions. In some subjects, however, the asymmetries were slightly larger when the normal, left eye was covered, whereas some other subjects were marginally better adapted when their right, adapted eye was covered. These differences in the degree of asymmetrical adaptation between the two monocular viewing conditions were on the order of as little as about 0.1 deg.

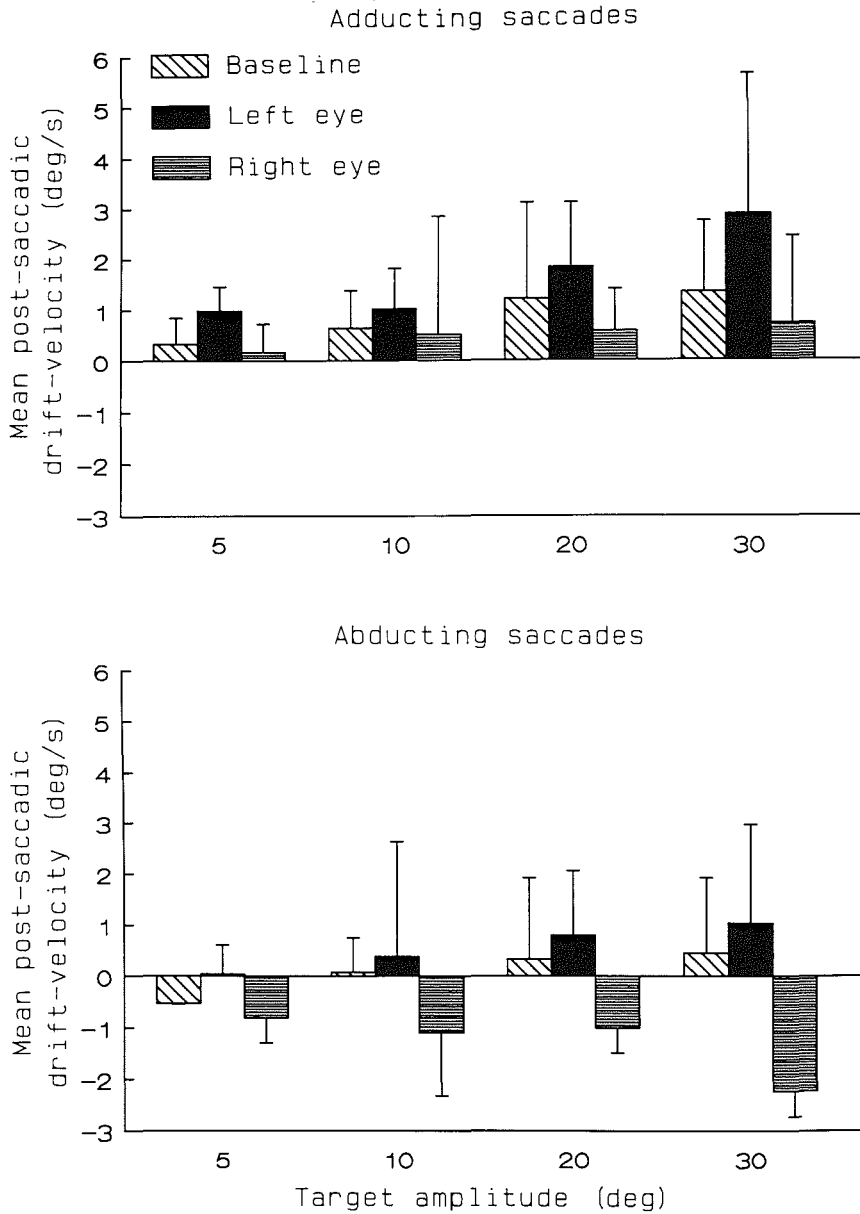
**Fig. 8.5** Mean vergence-deficits (+SD) for horizontal saccades (horizontally adapted) and for vertical saccades (vertically adapted) during binocular and monocular viewing.



To assess the degree of asymmetrical adaptation for either meridian, and for either viewing condition, I measured the vergence-deficits, calculated as the required change in vergence of concomitant saccades (see Methods) minus their actual change in vergence. These results are summarized in Fig. 8.5. The asymmetrical adaptations were almost complete during binocular viewing: vergence-deficits (Fig. 8.5) averaged only about 0.3 deg for all four target amplitudes along the two meridians, with maximal values of about 0.6 deg for 30 deg vertical saccades. None of my subjects perceived any double-images after 7 hours of conditioning, which indicates that all vergence-deficits remained within the fusional limits. With both eyes viewing, the overall degree of asymmetrical adaptation was about 73% of what was called for by the spectacles. When one eye was covered, the overall degree of asymmetrical adaptation dropped to about 52%, with vergence-deficits reaching maximal values of about 1 deg. Figure 8.5 might give the impression that, during monocular viewing, the degree of asymmetrical adaptation equalled a fixed percentage of what was called for by the spectacles, because the vergence-deficits increased somewhat linearly with larger target amplitudes. This apparent trend resulted, however, from pooling of the data. Close inspection of vergence-deficits of individual subjects revealed that there was, during monocular viewing, not such a very tight, linear relationship between the target amplitude and the amount of size-asymmetry. This supports my earlier findings (Chapters 6 and 7) that the asymmetrical adaptations are unlikely to result from a simple resetting of a few gain parameters which monitor the coordination of the two eyes.

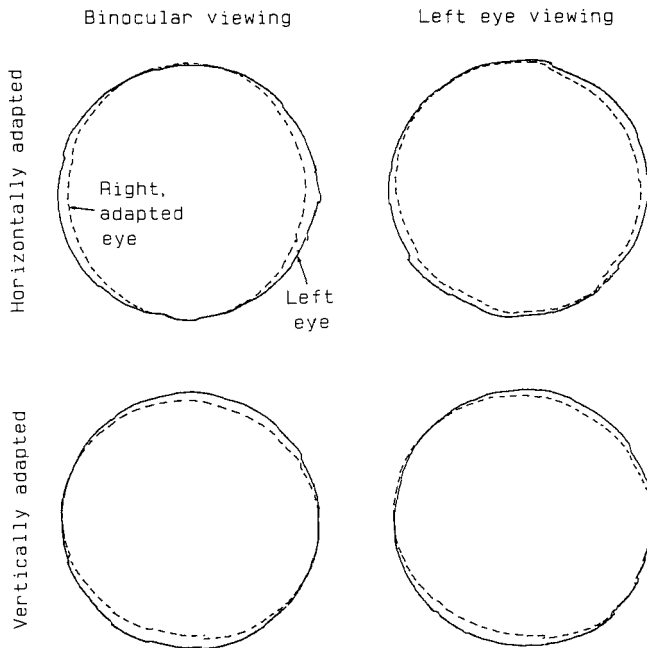
#### *Post-saccadic drift*

Asymmetrical adaptation of post-saccadic drift occurred in all subjects, but this adaptation was confined to horizontal saccades ( $F_{2,16} = 25.5$ ;  $P < 0.0005$ ). The following discussion will be limited to the changes that occurred, and not to the general characteristics of normal post-saccadic drift, as these were dealt with in Chapter 5. The plastic changes that occurred in the post-saccadic drift were such that they reduced the residual vergence-deficits at saccadic offset. This was true for binocular viewing, and, to the same extent, also for monocular viewing with either eye. I shall therefore not distinguish between these viewing conditions. For adducting saccades (Fig. 8.6, upper panel), the predominantly onward drift of the left, normal eye increased in mean velocity by about 0.6 deg/s. At the largest target amplitude (30 deg), however, the drift-velocity



**Fig. 8.6** Mean post-saccadic drift-velocities (+SD) for adducting saccades (upper panel) and abducting saccades (lower panel). The data relate to binocular viewing, both before and after asymmetrical adaptation.

had increased two-fold, up to about 3 deg/s. The right eye also drifted predominantly in the onward direction after adducting saccades, but its drift-velocity had dropped by about 0.3 deg/s, as compared to baseline values. For abducting saccades, the asymmetrical adaptation of post-saccadic drift was characterized by a change in direction of the right eye: instead of the normal, onward drift, the right eye now drifted backward. Its mean drift-velocities were on the order of 0.5 deg over the full range of target amplitudes. When the fellow eye made an abducting saccade, this eye drifted with a velocity about twice as high as before asymmetrical adaptation. All these results suggest that the pulse-step ratio, which characterizes the motor commands to the external eye muscles (see Chapter 2), was adaptively changed for horizontal saccades, when the spectacles called for asymmetrical, horizontal adaptation. When vertical adaptation was required, no changes in the yoking of post-saccadic drift occurred.



**Fig. 8.7** Typical recordings made during the smooth-pursuit task, after horizontal adaptation (upper panels) and after vertical adaptation (lower panels) of the same subject. Viewing was either binocular (left panels) or with the left, normal eye (right panels).

### *Smooth-pursuit*

Smooth-pursuit eye movements, made to the circularly moving target, were also asymmetrically adapted in all subjects. As with saccades, these adaptations occurred only along the appropriate meridian. The asymmetries were almost complete during binocular viewing, and somewhat less complete when one eye was covered. Figure 8.7 presents some typical recordings, which illustrate these plastic changes along either meridian (horizontal and vertical).

### *Perception*

After the first few hours that the subjects had worn the anisometric spectacles, they perceived the visual world as distorted. With the cylinder-axis positioned vertically, thus reducing the visual world along the horizontal meridian, objects on the left side of the visual field appeared larger and farther away than those on the right. Many subjects reported that they misjudged distances, and, as a consequence, occasionally bumped accidentally into objects on their left side. Also, horizontal surfaces appeared to be tilted: ceilings seemed to go down towards the right side, whereas floors gradually became higher on that side. With the lens-axis positioned horizontally, the distortions were exactly opposite: objects on the right side of the visual field now appeared larger and farther away than on the left, and horizontal surfaces were tilted in the opposite direction. These illusions confirm similar results by Ogle (1962). They did not become less within 7 hours of conditioning, but disappeared completely in about 2 minutes after the spectacles were taken off.

## DISCUSSION

The principal finding of these experiments is that asymmetrical adaptations of saccades and smooth-pursuit eye movements can be highly specific for either the horizontal or the vertical meridian. Such meridian-specificity has, as far as I know, not been reported before. Since the asymmetries were also present during monocular viewing, these meridian-specific plastic changes proved to be hard-programmed. These results nicely demonstrate how remarkably adequate the oculomotor system may be in adjusting to specific changes in the visual input. The speed of these adaptations (they were almost

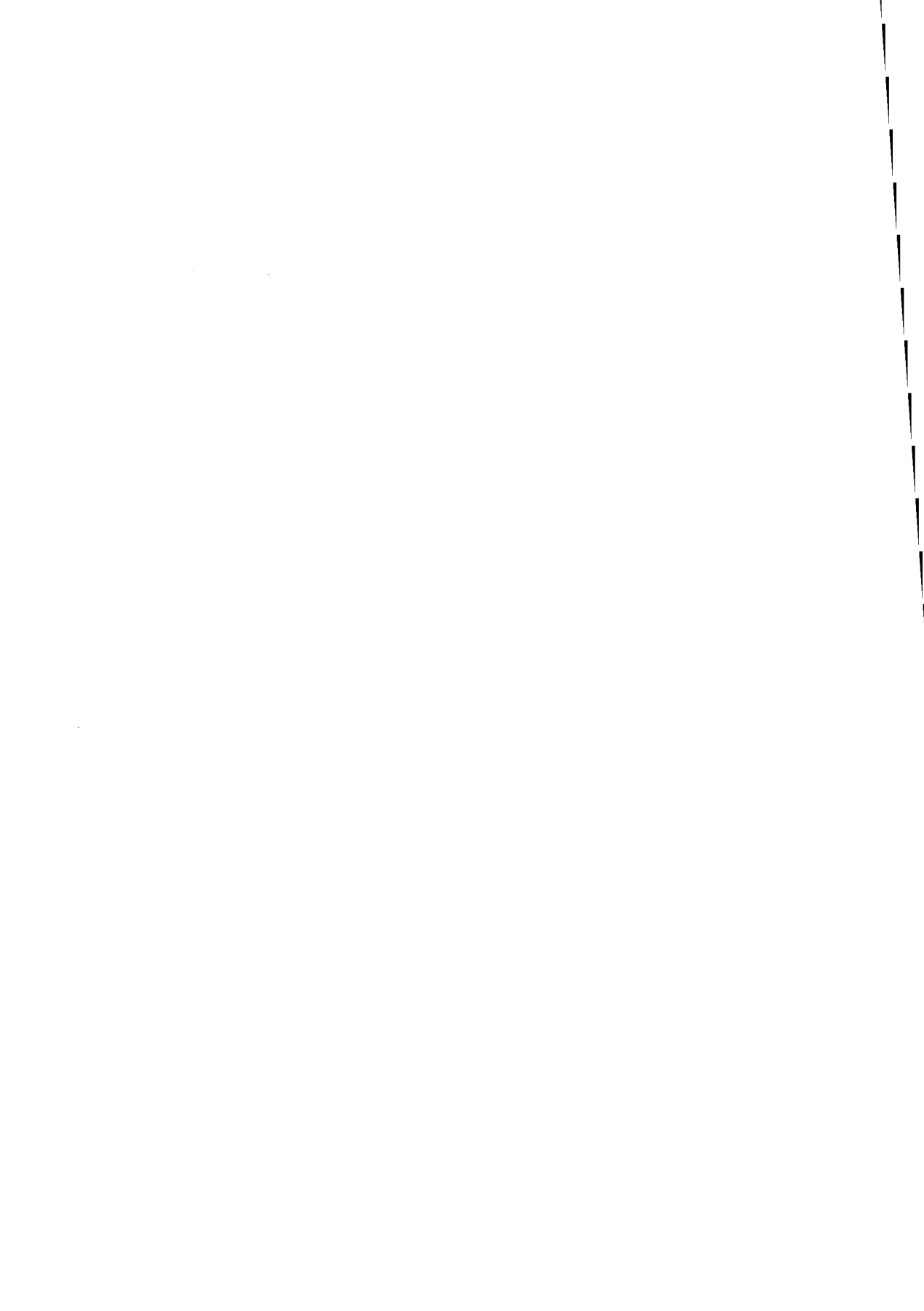
complete in as little as 7 hours of conditioning), and the apparent ease with which they came about, suggest that other changes, either specific or more general, may be dealt with accordingly. As I mentioned at the outset of this thesis, the most probable changes which the oculomotor system, like other sensory-motor systems, has to cope with, stem from growth, ageing, disease, injury or fatigue. Only by adapting adequately, and therefore specifically, to such changes, can eye movements be controlled accurately throughout a lifetime. The adaptations did not seem to consist of a simple resetting of a few gain parameters, as has been suggested before as a general way the oculomotor system may adapt (see Chapters 6 and 7), but, instead, of a point-to-point modification in the topology of sensory-motor maps. Such point-to-point adjustments conceivably add to the specificity of (asymmetrical) adaptations.

Obviously, these adaptations occurred only because there was a pressure for such specific changes. It is well-known, for horizontal saccades, that if there is a pressure for (symmetrical) adaptation in only one direction (either to the left or to the right), appropriate, direction-specific adaptive changes may take place. This was shown in patients with unilateral palsies of a medial or lateral rectus muscle (Kommerell et al., 1976; Abel et al., 1978; Optican et al., 1985), but also for saccades made in one direction towards a target that jumped consistently during the execution of that saccade, to another position, in order to induce direction-specific changes in saccade-size (Miller et al., 1981). In all these experiments, the direction-specific adaptations did not transfer to the opposite direction. It is unclear, however, whether they might have transferred to other meridians, thus reflecting a poor degree of meridian-specificity. This brings up the question how meridian-specific the adaptive properties of the saccadic subsystem, and of other oculomotor systems alike, can be. In case of the muscle- pareses, direction-specific adaptations presumably also developed in adjacent meridians. It is questionable, however, whether these developments of direction-specific adaptive changes in adjacent meridians resulted from poor meridian-specificity, or from a specific pressure for such direction-specific changes along those meridians. The latter appears to be more probable, because saccades made along those adjacent meridians would also involve the action of the weakened eye muscle. Therefore, adaptive changes would be called for that were proportional to that action.



In the present experimental design, the whole visual world of one eye was reduced in magnitude along one meridian. Therefore, in case of a size-reduction along the horizontal meridian, there was not only a pressure for purely horizontal saccades to adapt asymmetrically, but also for the horizontal components of all oblique saccades. Thus, even if I had recorded oblique saccades, my present experimental design would not have been appropriate to assess how truly meridian-specific, i.e., without any transfer to adjacent meridians, might be.

Deubel (1987) had subjects make saccades, in various directions along various meridians, towards a target that jumped. This design was quite similar to the one adopted by Miller et al. (1981), with the exception that Deubel examined various meridians. For saccades made along one meridian, he let the target jump, during the execution of the saccade, consistently in one direction. He found that saccades made in that direction, along that specific meridian, gradually changed in size, as a result of this conditioning (adaptation). He also found that this direction-specific adaptation transferred, to a lesser extent, to adjacent meridians, with a meridian-specificity on the order of 30 deg to either side. However, this does not necessarily imply that meridian-specificity cannot be even better. In his experimental design, there was no pressure for any higher meridian-specificity, because he did not try to induce a different degree of adaptation along adjacent meridians. Therefore, meridian-specificity might well be better than about 30 deg, provided there was a specific pressure for it. An interesting question that has yet to be answered is how narrow the limits of such meridian-specific adaptations might actually be. The narrower these limits were, the better equipped the oculomotor system would be to adapt to any possible changes. Another interesting question, which will be dealt with in the following chapter, is whether asymmetrical adaptations can occur along any meridian, i.e., also along oblique meridians, and if so, whether they are really meridian-specific or whether they merely consist of asymmetrical adaptations of their horizontal and vertical components.



## CHAPTER 9

# MERIDIAN-SPECIFIC ASYMMETRICAL ADAPTATION OF OBLIQUE SACCADES

### INTRODUCTION

In the previous chapter, I demonstrated asymmetrical adaptations of horizontal and vertical saccades, that were specific for either the horizontal or the vertical meridian. I shall now assess whether such asymmetrical adaptations can also be specific for oblique meridians, and, consequently, apply largely to oblique saccades. The relevance of establishing whether or not (asymmetrical) adaptations of saccades can be specific for oblique meridians will now be explained.

Oblique saccades are made through the joint action of multiple external eye-muscles which have different lines of action. At an immediate pre-motor level, separate regions have been identified in the brainstem, which are involved in the generation of horizontal and vertical saccades. Oblique saccades require the concerted action of these regions (Luschei and Fuchs, 1972; Keller, 1974; Henn and Cohen, 1976; Büttner et al., 1977; Hepp and Henn, 1983; King et al., 1986). Therefore, oblique saccades result from the combined generation of their horizontal and vertical components. The way in which a central command to generate an oblique saccade is translated into its horizontal and vertical components, is still subject to debate. Various, somewhat conflicting, models for this decomposition have been proposed (Van Gisbergen et al., 1985; Tweed and Vilis, 1985; Fuchs et al., 1985). None of these, however, can exhaustively account for the various characteristics of oblique saccades (Grossman and Robinson, 1988).

The important point in the present context is, however, in what stage of saccade-generation the asymmetrically adaptive changes take place. For the adaptations described in Chapter 8, which were specific for either the horizontal or the vertical meridian, these

adaptations could have occurred either before or after decomposition of the central motor commands into their horizontal and vertical components. This would also apply to oblique saccades, that had to adapt along either the horizontal or the vertical meridian. If the asymmetrical adaptation occurred after decomposition, the central commands could, in principle, remain unchanged, requiring only a modification of either the horizontal or the vertical components. However, if the adaptive changes indeed took place after decomposition, they could only be specific for the horizontal or the vertical meridian, and not for oblique meridians, as will now be explained with the help of Fig. 9.1. Figure 9.1a schematically illustrates how an oblique saccade can be composed, through vector-summation, of its horizontal and vertical components. A similar schema is presented for an oblique saccade along the orthogonal meridian (Fig. 9.1b). If an adaptive size-reduction were required for the oblique saccade of Fig. 9.1a, this could, in principle be achieved by a simple, adaptive shrinking of its horizontal and vertical components (dotted arrows in Fig. 9.1c). However, if this were the way in which asymmetrical adaptations of all saccades are established, i.e., by uniformly changing the gain of the horizontal and vertical components of oblique saccades, then the oblique saccades along the orthogonal meridian would be equally affected (cf. Fig. 9.1c with Fig. 9.1d). In that case, asymmetrical adaptation would not be specific for oblique meridians. This would, in turn, impair the flexibility of the oculomotor system to adapt adequately. If, however, asymmetrical adaptation of oblique saccades occurred before decomposition, such adaptation could, in principle, indeed be specific for oblique meridians. To find out in what stage of the generation of oblique saccades the asymmetrically adaptive changes take place (i.e., before or after decomposition into horizontal and vertical components), I shall address the question whether asymmetrical adaptations of saccades can be specific for oblique meridians. Furthermore, I shall examine if any such adaptation may also occur in smooth-pursuit eye movements.

## METHODS

### *Subjects*

Ten normal subjects took part in these experiments. They were between 20 and 44 years old. None of them had any history of ocular or oculomotor pathology. Four subjects

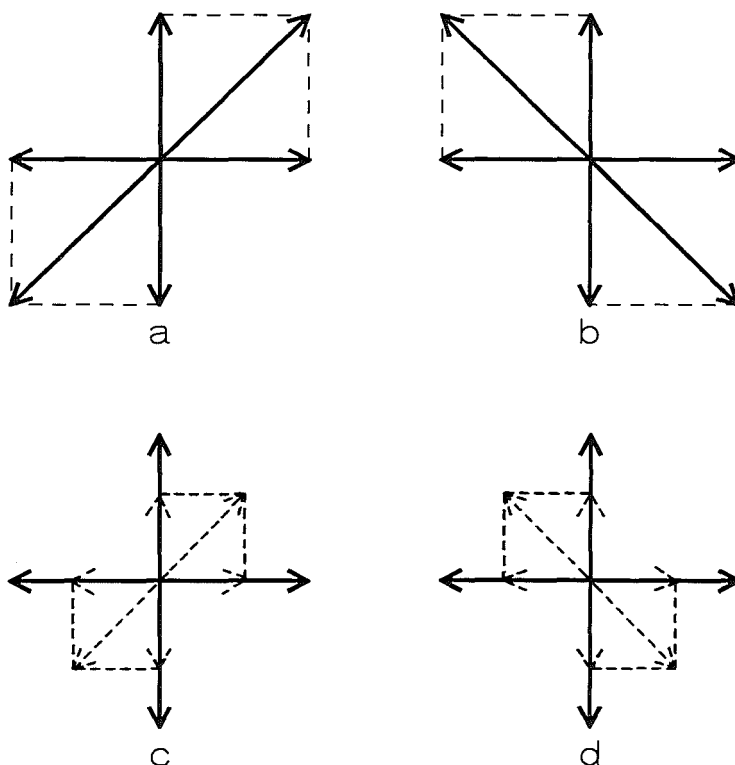
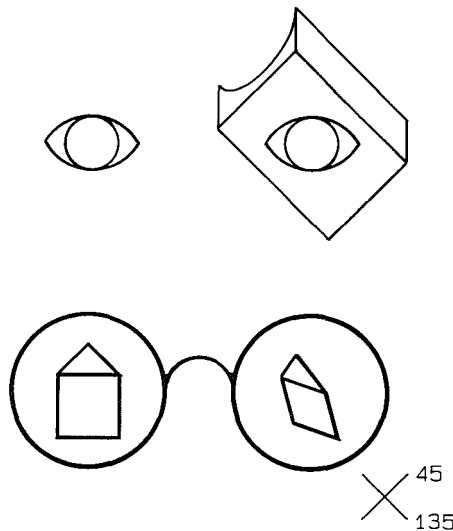


Fig. 9.1 Schema illustrating the effects on the size of orthogonal, oblique saccades if adaptive size-changes were caused by a uniform resetting of the horizontal and vertical components of all oblique saccades. In a) a normal, oblique saccade, made along the 45 deg meridian, is schematically drawn with its horizontal and vertical components. A similar schema for an orthogonal saccade is presented in b). Suppose an adaptive size-reduction of the oblique saccade presented in a) occurred after decomposition of its central motor commands into its horizontal and vertical components. The size-reduction of the oblique saccade would then be secondary to the component-adaptations. This is indicated in c) by means of dotted arrows. As a consequence of this uniform resetting, other oblique saccades, such as the one orthogonal to the saccade in c) would also be affected by this uniform, component-plasticity (d). Meridian-specificity of saccadic adaptations would then be impossible for oblique meridians.

were myopic. Three of these myopes wore contact-lenses. The fourth myopic subject had spectacles (-1 D on either side), but he virtually never wore them. Visual acuities were, in all subjects (the myopes wearing their own corrective lenses) 5/5 or better. Binocular vision, which was considered essential for asymmetrical adaptation, was ascertained by means of stereopsis test charts (TNO test for stereoscopic vision). Stereoscopic vision was normal (thresholds 120 sec arc or better) in all subjects.

### Conditioning

The experimental procedures were almost identical to those described in Chapter 8. I shall therefore present only a brief description of the current experimental design (for further details, refer to the previous chapter). As in Chapter 8, I supplied the subjects with a cylindrical lens (-3 D) in front of the right eye. This time it was positioned obliquely (45 deg, according to conventional descriptions, as discussed in Chapter 6). Again, the left eye was not provided with a lens. The effects on the proportions of the visual images of these anisometric spectacles are illustrated in Fig. 9.2.



**Fig. 9.2** Schema of the effects on the visual image of anisometric spectacles containing a negative, cylindrical lens positioned at 45 deg in front of the right eye. Along the 45 deg meridian, as seen through the spectacles, the image is reduced in size, whereas along the orthogonal, 135 deg meridian no size-change is inflicted. The left side of the spectacle-frame is not provided with any lens (cf. with Fig. 6.1).

For the right eye, the size of the image, as seen through the spectacle-lens, was reduced along the meridian that ran from the bottom left to the top right. I defined this meridian as the 45 deg meridian. Along its orthogonal meridian (135 deg meridian), the visual image was not affected in size. Obviously, the visual images for the left, naked eye, remained unchanged. The subjects wore these anisometric spectacles for 7 continuous hours, meanwhile carrying on with their normal daily routine. Following this

conditioning-period, I performed the actual measurements, during which the subjects continued to wear the anisometric spectacles. Baseline recordings were obtained on another day, either before or well after the day of adaptation.

### *Recording sessions*

Again, the experimental conditions during the recording of eye movements were very similar to those in the previous chapter. This time, however, the targets, which consisted of He-Ne laser beams projected onto the white iso-vergence surface, were not only positioned along the horizontal or the vertical meridian, but also along either the 45 deg meridian or along the 135 deg meridian. The positioning of the targets along any of the four various meridians was always symmetrical about the straight-ahead position. Target amplitudes were, for the oblique meridians, 10, 14, 30 or 42 deg. For the horizontal as well as for the vertical meridian, target amplitudes equalled 10 or 30 deg. Oblique target amplitudes of 14 and 42 deg were chosen to allow comparison of the horizontal and vertical components of oblique saccades (with component target amplitudes of 10 and 30 deg, respectively) to horizontal and vertical saccades made between targets positioned 10, respectively 30 deg apart. However, as this comparison will go beyond the scope of this chapter, I shall currently confine myself to asymmetrical adaptations of oblique saccades.

Just as in the previous chapters, subjects made repetitive saccades between stationary targets at a comfortable, standardized pace, which was indicated by a sound. Data-collection, which lasted 12 s for every trial, was initiated by the subjects themselves, whenever they felt ready, by pressing a button. Viewing was binocular or monocular with either eye. Movements of the head were restricted through a forehead- and chin-support, and additional straps. The order of the trials was randomized for every subject. The subjects were instructed to fixate either of the targets alternately as accurately as possible, and also to refrain from blinking during the collection of data, in order to prevent the occurrence of eye movements related to blinks (Collewijn et al., 1985). The horizontal and vertical components of the eye movements of both eyes were recorded simultaneously by means of magnetic sensor coils. These recordings were digitized and stored on disk for off-line analysis. When the search coils were placed onto each eye, following the 7 hours of conditioning, care was taken that one eye remained covered at

all times. This was done to prevent any symmetrical visual input, that might revert any asymmetrical adaptation that had developed.

After all saccade-trials were completed, I conducted the smooth-pursuit experiments, in a way identical to the one in previous chapters. Subjects had to track a circularly moving target as accurately as possible (target-velocity: 11 deg/s; diameter of circle: 30 deg). This task was performed with both eyes viewing, and also during monocular viewing with either eye.

Finally, I recorded steady, monocular fixations of targets with known positions, made both with and without spectacles, to serve a careful fine-tuning of the calibrations (see Chapter 3). These recordings also allowed for assessing, for each individual subject, how much the movements of the right eye should ideally become smaller along the appropriate meridian after adaptation to the spectacles. It will be recalled that the magnitude of this size-reduction may vary between subjects due to individual differences in the distance between the spectacle-lens and the point of rotation of the eye (Chapter 6).

#### *Data analysis*

As I explained in Chapter 3, the recording-technique I employed only recorded horizontal and vertical components of eye movements. Therefore, the trajectories of the oblique saccades made in the present experiments were later digitally reconstructed from corresponding sample-points of the individual horizontal and vertical recordings. These reconstructed, oblique saccades were then, again, broken down into two orthogonal components: this time, however, not along the horizontal and vertical meridians, but along their oblique, 45 deg and 135 deg meridians. This transformation allowed that the main components of the oblique saccades could be studied, just as horizontal and vertical saccades were studied in previous chapters, with respect to their main, horizontal or vertical components, respectively. For clarity, when horizontal saccades were examined in previous chapters, their vertical components were neglected. In case of vertical saccades, their horizontal components were not considered. In the present experiments on oblique saccades, those made along either the 45 deg or the 135 deg meridian, were also studied with respect to their main, oblique component;



their components along the orthogonal meridian were disregarded. The main components of the oblique saccades were analysed by a computer programme, which adopted the standard criteria, that were also used for horizontal and for vertical saccades (Chapter 5). In short, saccades were scored if they met specific velocity- and amplitude-criteria. Whenever a saccade was scored, this computer programme calculated saccadic size and direction. In addition, the mean post-saccadic drift-velocity and drift-direction was determined. These data were thereafter submitted to another computer-programme (SPSS-X), which was used to perform any statistical calculations. Statistical testing consisted of a multivariate analysis of variance (MANOVA), in which the requirements of balanced data, normal distributions and homogeneous variances were observed (for further details on the statistics, see the previous chapters).

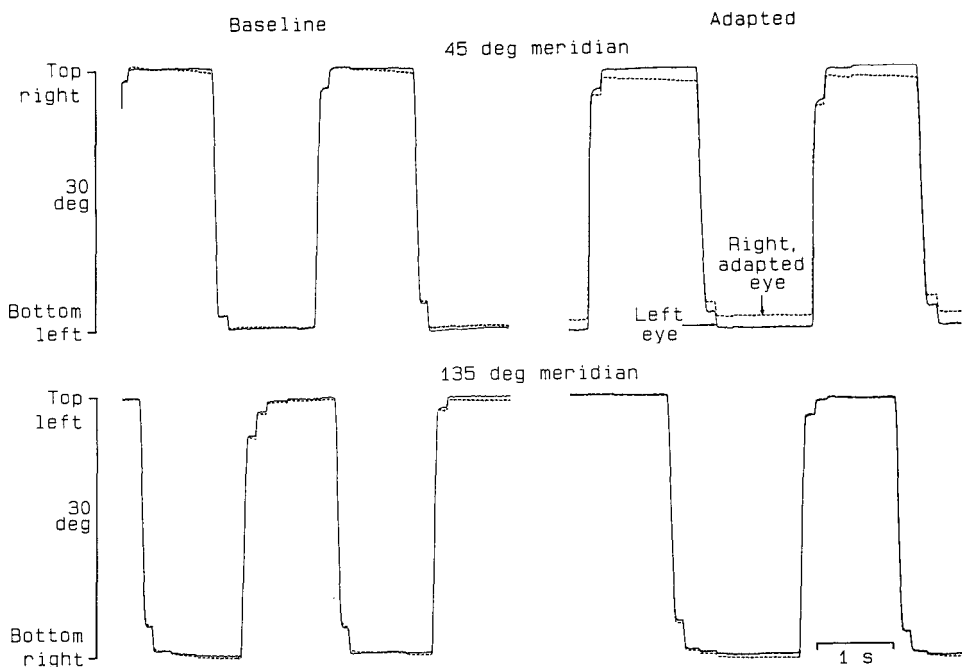
An analysis of measurement-errors is appropriate. It turned out that, due to a systematic error in the recording equipment, eye positions of the right eye along the 45 deg meridian were recorded too small by about 1.5%, whereas eye positions of the same eye along the 135 deg meridian were recorded too large by about 1%. Similar deviations for the left eye were less than 0.5% along either of these two meridians. As a consequence, the differences in saccadic size between the two eyes per se, which reflected the degree of asymmetrical adaptation, were not entirely correct as such, and they should always be compared with the baseline-values. However, the vergence-deficits, which were calculated as the required difference in saccade-size between the two eyes minus the actual difference in saccade-size, were hardly subject to these systematic errors, because both the required and the actual differences in saccade size between the two eyes were determined from recordings from both eyes.

As was also mentioned in previous chapters, slight displacements of the spectacles were likely to occur during the running of the experiments. Such displacements would result in a shifting of the target-positions as seen by the right eye, which was supplied with the spectacle-lens. For that reason I did not determine position-errors at saccadic offset for each eye as a measure of the degree of asymmetrical adaptation. Instead, I related the actual difference in saccadic size between the two eyes to the difference that was required by the spectacles, as ascertained from monocular, steady fixations of targets with known positions.

## RESULTS

### *Saccades*

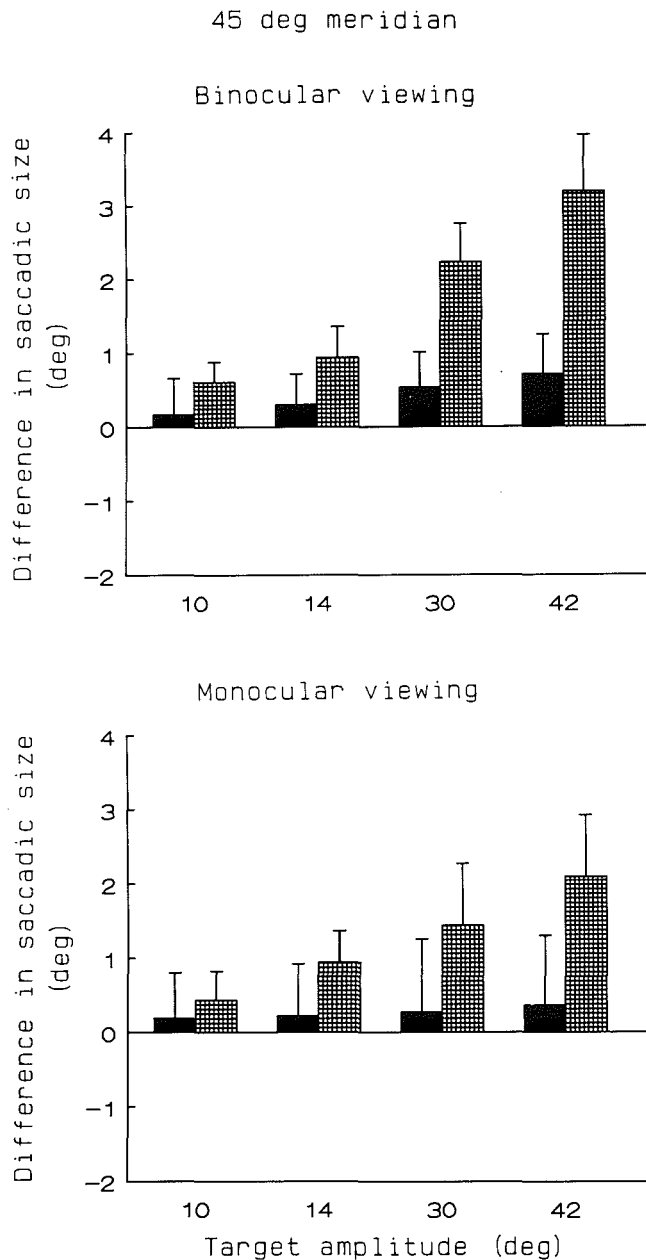
Asymmetrical adaptations of oblique saccades occurred in all subjects. These asymmetrical adaptations were specific for the appropriate, 45 deg meridian ( $F_{1,9} = 66.9; P < 0.0005$ ). Along the orthogonal, 135 deg meridian, no asymmetrical changes had developed during 7 hours of conditioning. This result corresponded with the requirements of the spectacles. Figure 9.3 displays some typical recordings of oblique saccades made along either meridian, both before and after adaptation. This figure shows that, before adaptation (left panels), oblique saccades were conjugate along either meridian (45 or 135 deg), thereby complying with Hering's law of equal innervation.



**Fig. 9.3** Typical binocular recordings of oblique saccades made along the 45 deg meridian (upper panels) and along the 135 deg meridian (lower panels). Left panels: baseline recordings. Right panels: after adaptation. Only the main, oblique saccadic components are displayed. Viewing was with the left eye.

After adaptation to the anisometric spectacles, however, the oblique saccades, made along the 45 deg meridian, were smaller by about 2.1 deg in the right eye than in the fellow eye (target amplitude: 30 deg), whereas saccades made along the orthogonal, 135 deg meridian had not changed asymmetrically in size. Note that the recordings of Fig. 9.3 were made during monocular viewing with the left eye. They therefore illustrate that these asymmetrical adaptations were hard-programmed. These results also show that the asymmetrical adaptations were truly meridian-specific, and that the observed differences in saccadic size between the two eyes did not merely result from an adaptive modification of the horizontal and vertical components of oblique saccades. If the latter had indeed been the case, oblique saccades towards the right, for instance, would have been equally adapted for the 45 deg meridian (i.e., saccades towards the upper right) as for the 135 deg meridian (i.e., saccades towards the lower right).

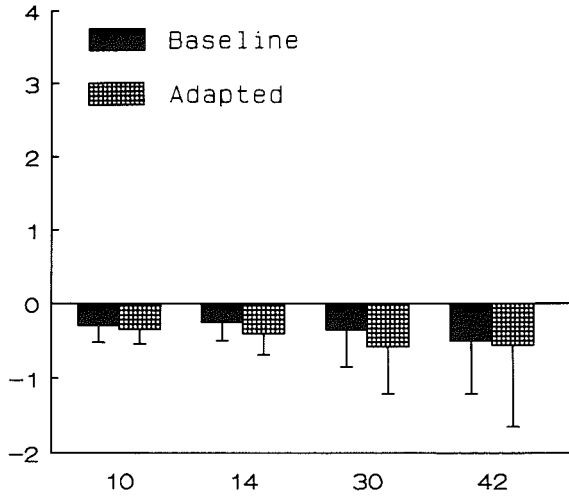
To quantify these asymmetrical adaptations, I measured the difference in size between concomitant saccades of the two eyes, calculated as the magnitude of saccades made by the left eye minus the magnitude of saccades of the right (adapted) eye. Because variations in the degree of asymmetrical adaptation between subjects were very small, I shall focus on the main trends. Figure 9.4 presents mean values for the differences in saccade-size between the two eyes, both before and after adaptation, for the four various target amplitudes. Distinctions have also been made between the various viewing conditions (binocular viewing versus monocular viewing with either eye). As the size-differences were not significantly dependent on whether the right eye or the left eye was viewing, the data of these two monocular viewing conditions were pooled. Along the adapted, 45 deg meridian the differences in saccadic size became, not surprisingly, larger at larger target amplitudes ( $F_{3,27} = 46.8$ ;  $P < 0.0005$ ). During binocular viewing, the right, adapted eye made saccades along the 45 deg meridian, that were about 6% smaller than before adaptation (all four target amplitudes), whereas the saccades of the left eye had not changed in size. The magnitudes of these adaptive size-asymmetries could, for the binocular viewing condition, become as large as 2.6 deg, compared to baseline-values (target amplitude: 42 deg). Figure 9.4 clearly shows that, along the orthogonal, 135 deg meridian, however, differences in saccade-size between the two eyes were just as large as before adaptation. Figure 9.4 also demonstrates that, when viewing was monocular, this meridian-specificity was still present. The magnitudes of the adaptive asymmetries were then, however, about 30 % smaller than during binocular viewing. As with



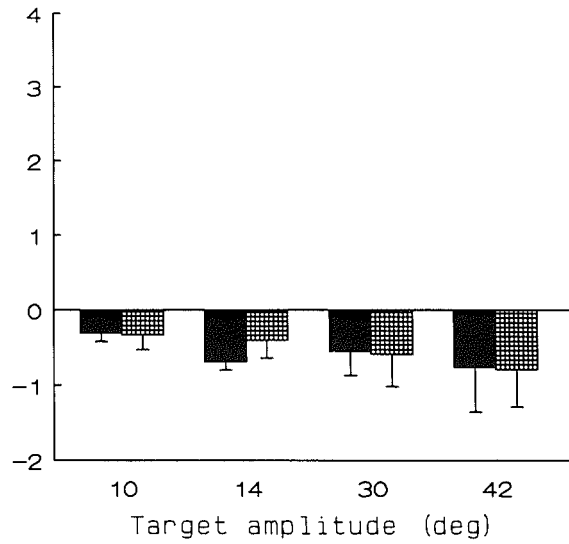
**Fig. 9.4** Mean differences in saccadic size between the two eyes (+ SD), computed as the magnitude of saccades of the left eye minus the magnitude of concomitant saccades of the right eye, for either meridian (left page: 45 deg meridian; right page: 135 deg meridian) at the four various target amplitudes. Baseline-data have been included. Top panels relate to the binocular viewing condition. Bottom panels represent data obtained during monocular viewing with either eye.

135 deg meridian

Binocular viewing



Monocular viewing



asymmetrical adaptations along the horizontal and vertical meridians (Chapters 6 through 8), data of individual subjects showed that the magnitude of the asymmetries in saccadic size was not a fixed percentage of what was required by the spectacles. Instead, it frequently varied for the various target amplitudes, which suggests once more that the asymmetrical adaptations did not come about by a simple resetting of a possible common gain factor (for a discussion on this topic, see Chapter 6).

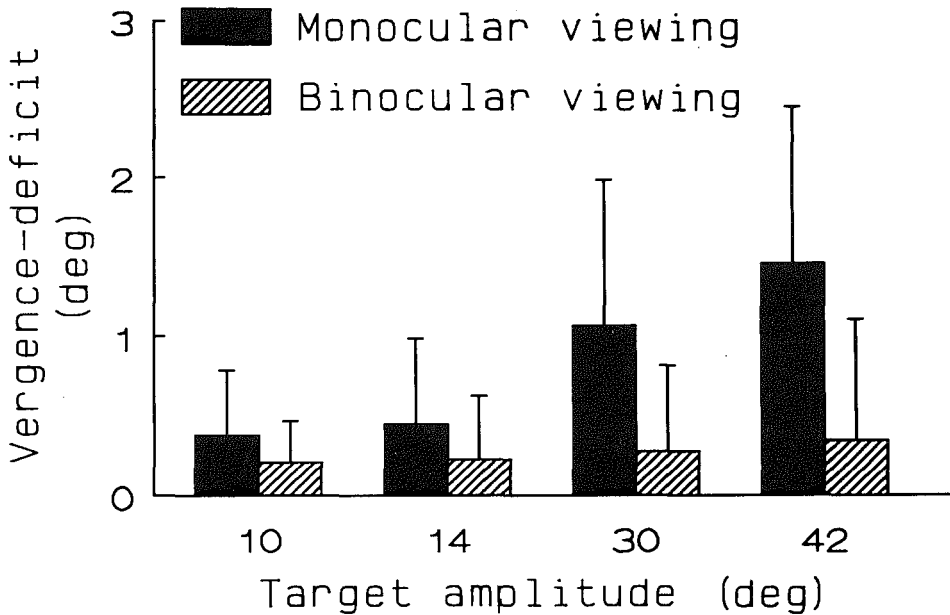


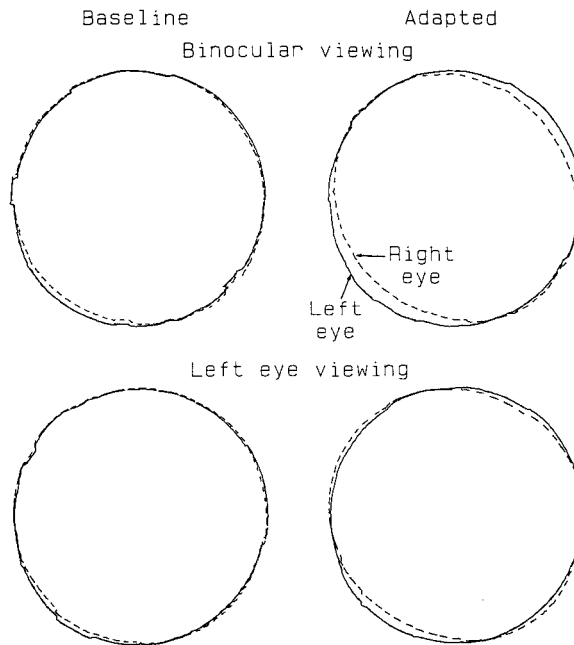
Fig. 9.5 Mean vergence-deficits (+ SD) for saccades made along the adapted, 45 deg meridian at the four various target amplitudes. Data relate to monocular viewing with either eye (black bars) and to binocular viewing (grated bars).

As a next step, I determined how complete the asymmetrical adaptations were. The degree of asymmetrical adaptation was described, just as in the previous chapters, in terms of the vergence-deficit present at the end of each primary saccade. Vergence-deficit was calculated as the required difference in saccadic size between the two eyes minus the actual difference in saccadic size. The required difference was determined, for every individual subject, from steady, monocular fixations with either eye of targets with known positions. Mean values of vergence-deficits are presented in Fig. 9.5. The data are confined to the 45 deg meridian, i.e., the meridian along which the asymmetrical adaptation was required. It is clear from this figure that the asymmetrical adaptations were almost complete during binocular viewing: vergence-deficits then were as little as about 0.3 deg over the full range of target amplitudes. This corresponded nicely with the fact that most subjects experienced fusion of the targets. Although all other subjects clearly saw two distinct images of each target, one being normal and the other being distorted through the action of the cylindrical lens, these images were always seen on top of each other, which was also in agreement with the small vergence-deficits. When one eye was covered, the asymmetrical adaptations were less complete ( $F_{2,18} = 14.6$ ;  $P < 0.0005$ ): the vergence-deficits then were about two- to four-fold larger than during binocular viewing, and could become as large as about 1.5 deg for the largest target amplitude of 42 deg. When compared with the meridian-specific, asymmetrical adaptations of saccades along the horizontal and vertical meridian (Chapter 8), the adaptive changes along the 45 deg meridian were equally complete and equally meridian-specific.

In contrast with the asymmetrical changes in saccadic size, no significant adaptive changes occurred to the post-saccadic drift ( $F_{1,9} = 0.63$ ;  $P > 0.40$ ). It will be recalled that this was also the case with asymmetrical adaptations of vertical saccades (see Chapters 6 through 8). Because asymmetrical changes in post-saccadic drift did develop in horizontal saccades, following adaptation along the horizontal meridian (Chapters 6 through 8), these results suggest that such adaptations might be a property restricted to the horizontal meridian.

### *Smooth-pursuit*

When the subjects tracked the circularly moving target (velocity: 11 deg/s), asymmetrical adaptation was, just as with saccades, clearly present along the appropriate, 45 deg meridian. This is illustrated in Fig. 9.6, which shows typical, binocular recordings made before and after adaptation. When one of the eyes was covered, this meridian-specific adaptation was still present, although to a slightly lesser extent. These results, which were virtually the same for all subjects, showed that smooth-pursuit eye movements may also adapt asymmetrically along a specific, oblique meridian, and that these adaptations were hard-programmed. Compared with similar adaptations along the horizontal and vertical meridian (Chapter 8), there was neither a significant difference in the meridian-specificity nor in the magnitude of these plastic changes of smooth-pursuit eye movements.



**Fig. 9.6** Typical binocular recordings made during the smooth-pursuit task, both before (left panels) and after adaptation (right panels). Viewing was binocular (upper recordings) or with the left eye (lower recordings).



Just as with saccades, these oblique adaptations did not merely result from asymmetrical adaptations of the horizontal and vertical components of such eye movements, but from a true specificity for one oblique meridian. During binocular viewing, the target was always seen either fused or as two distinct, though superimposed images, which suggests that the adaptations were, for functional purposes, complete.

### *Perception*

As had also been the case in the preceding experiments on short-term asymmetrical adaptations (Chapters 7 and 8), all subjects reported that they experienced, after several hours of conditioning, a distortion of the visual world. This time, the distortions consisted of a shrinking of objects in the upper visual field, as well as an increase in distance between those objects and the subject. Similar findings were reported by Ogle (1962). The illusions did not diminish during the 7 hours in which the spectacles were worn. After the spectacles were taken off, however, the illusions disappeared very rapidly.

## DISCUSSION

The most important finding of these experiments is that the asymmetrical adaptations were truly specific for a single, oblique meridian. Such a demonstration of oculomotor plasticity has, to my knowledge, not been reported before. Since asymmetrical adaptations can also be induced specifically along either the horizontal or the vertical meridian (Chapter 8), these results strongly suggest that asymmetrical adaptations of saccades, and also of smooth-pursuit eye movements, may take place along any meridian. Such a versatile plasticity of these two oculomotor subsystems would conceivably contribute to their tolerance to any specific changes that might occur to them throughout a lifetime.

The present results also demonstrate that the asymmetrical adaptations along a specific, oblique meridian did not merely consist of adaptive changes of the horizontal and vertical components of the oblique eye-positions. Otherwise, eye movements made along the orthogonal meridian would also have been adapted, and to the same extent, although

this result would have been functionally maladaptive. Deubel (1987), who induced adaptations of oblique saccades (of both eyes) in monkeys, as well as in human subjects, by means of a target that jumped consistently in a specific direction during the execution of a saccade, also found that these adaptations could not be explained by plastic changes of the individual horizontal and vertical saccadic components. Deubel suggested that the adaptive changes of oblique saccades take place before decomposition of the central command to generate a saccade into its horizontal and vertical components. My results are in line with such a possibility, although I hasten to add, that the model Deubel (1987) has proposed does not address the asymmetries of adaptation between the two eyes that I studied.

Deubel's experimental conditions (1987) enabled him also to study how narrowly the size-adaptation of saccades was tuned around the trained direction. It turned out that the adaptations induced for a specific (oblique) direction transferred partially to other, adjacent directions. This transfer became weaker as the adjacent direction was farther off the main, adapted direction. The "tuning curves" had a width of about 30 deg on either side of the main direction. The width of a tuning curve corresponds inversely with the specificity of the adaptation for a given direction or for a given meridian. As I already pointed out in the Chapter 8, Deubel did not impose any specific pressure for differential adaptation (or absence of adaptation) in the adjacent directions, because in the training phase only saccades in the direction that was to be adapted were elicited. Therefore, the tuning curves he found may relate only to situations in default of specific pressure for differential adaptation in adjacent directions. If there were indeed a more specific pressure for differential adaptation in adjacent directions, the tuning curves might perhaps be even narrower. In my experimental design, the spectacles required a very gradual change in the degree of (asymmetrical) adaptation along adjacent meridians. Therefore, my experiments were not suitable for assessing the minimum width of such tuning curves, i.e., the maximal meridian-specificity of such (asymmetrical) adaptations.

## CHAPTER 10

### GENERAL DISCUSSION AND CONCLUSIONS

In this thesis I have systematically studied some adaptive properties of saccadic eye movements in order to assess, both quantitatively and qualitatively, how the saccadic subsystem responds to a consistent pressure for a reprogramming of its commands. Although I focussed my study on saccadic adaptations, and, to a lesser extent, on adaptations of smooth-pursuit eye movements to the wearing of anisometric spectacles, I was essentially interested in sensory-motor adaptations at large. Concentrating on these two oculomotor subsystems, I have tried to increase our understanding of how the central nervous system may generally cope with any sensory-motor changes that presumably take place throughout a lifetime. Such changes unavoidably result from growth, ageing, disease, injury or fatigue, and they are likely to occur haphazardly, at variable locations, along variable time-courses as well as with variable degrees of severity. Because they presumably affect the quality of sensory-motor control, the sensory-motor systems involved should be capable of adapting adequately to them in order to safeguard their proper functioning.

One of the major findings of the research presented in this thesis was that saccades and smooth-pursuit eye movements may adapt in such a way to anisometric spectacles that the two eyes make movements of unequal size. Normally, however, these eye movements are thought to be perfectly conjugated. This notion of perfect yoking is frequently referred to as Hering's law of equal innervation. Although even normal, unadapted saccades do not follow this law rigidly (Chapter 5), the magnitude of these violations is negligible compared to the dramatic changes in size between saccades of the two eyes that may occur after asymmetrical adaptation to anisometric spectacles. Importantly, these asymmetries were also present when one eye was covered, which demonstrates that they had become part of the basic programming of saccades. An interesting question is why these adaptations take place. A tentative explanation may be the following. Even

before adaptation, there is a hard-programmed, close coupling between movements of the two eyes, also when one eye is covered. This was observed by Hering, which led him to formulate his law (1868). This hard-programmed, basic yoking might ease the strain on the saccadic subsystem to program, for two eyes simultaneously, saccades that have to be accurate, and at the same time, fast. As saccades have such high velocities that visual feedback is unlikely to play an important role, if any, during their execution, this demand is presumably very high. Possibly, such basic yoking might also be beneficial to other oculomotor subsystems. In case of viewing through anisometric spectacles, the basic, unadapted level of the degree of yoking would be more of a nuisance than of any help for the generation of saccades of the appropriate size in the two eyes. Therefore, a hard-programmed resetting of the ratio of this basic coupling between the two eyes would be needed to relieve the saccadic subsystem from the consistent burden of asymmetrical visual input. Thus, the inherent yoking of saccades, and the capacity to readjust the basic setting of this yoking, may be purely economical.

Hering (1868) originally observed that the two eyes are so well coordinated that they always look at the same object. He stated that this coordination is so perfect that the two eyes move as though they were one single organ, which he called the double-eye (*Doppelaug*). Based on this observation, he formulated his law on the so-called equal innervation of the two eyes. Importantly, his law is merely a description of the high degree of yoking of the eyes. It does not, however, relate directly to the actual motor commands (or "innervation") of the two eyes, which may not at all be equal in case of asymmetrical differences in the physical properties of, for instance, the motoneurons, the external eye muscles or the tissues in which the eyeballs are suspended. As explained before, such asymmetries are very likely to exist. Normally, the high degree of yoking is desirable for a proper binocular control of eye movements. This conjugacy is obtained and maintained through adaptation, because normal, every-day life conditions exert a certain pressure for such conjugacy. It was shown in monkeys that this conjugacy may deteriorate when one eye is deprived of vision for one week (Vilis et al., 1985; Viirre et al., 1987). Therefore, the high degree of normal yoking of the eyes results from the capacity of the oculomotor system to adapt; it does not originate from a fixed and rigid coupling of motor commands which are equal for the two eyes. In case changes occur within the oculomotor system, for example due to pathology or growth, the adaptation will restore the degree of yoking within a certain adaptive range. If changes occur

outside the oculomotor system, such as caused by anisometric spectacles, the coordination between the two eyes will be adjusted (also within a certain range) up to the point where yoking becomes functionally complete, which means that the eye that perceives a smaller visual image will make a smaller eye movement than its fellow eye. In that sense, asymmetrical adaptations actually confirm Hering's law instead of violating it, because, after adaptation, the two eyes will always look at the same object. Obviously, Hering did not have this in mind when he laid down his law.

The functional significance of asymmetrical adaptations is that it prevents the occurrence of diplopia that would otherwise ensue. Erkelens et al. (1989b), who initiated experiments of the kind described in this thesis, found in their subjects that asymmetrical adaptations of saccades were more complete along the vertical meridian than along the horizontal meridian. Because the fusional limits for vertical disparities are narrower than for horizontal disparities (Fender and Julesz, 1967; Piantanida, 1986; Erkelens, 1988), Erkelens et al. (1989b) suggested a connection between loss of fusion and the degree of asymmetrical adaptation, in the sense that asymmetrical adaptation would proceed to a level at which fusion was maintained. This does not imply, however, that loss of fusion is the appropriate stimulus for asymmetrical adaptations, as will now be argued. My experiments, which were conducted on a larger number of subjects than used in the study by Erkelens et al., showed that the asymmetrical adaptations could be, for individual subjects, better along either meridian (horizontal or vertical). Therefore, the correlation between the degree of asymmetrical adaptation and the fusional limits is by no means very strong. In addition, the adaptations along the horizontal meridian were frequently much better than would have been strictly necessary for the fixation-disparities present at saccadic offset to fall within the fusional limits, which are now assumed to be 1-2 deg (Fender and Julesz, 1967; Erkelens, 1988). Furthermore, some of my habitual spectacle-wearers were not well enough adapted, along the vertical meridian, to prevent the perception of double images, despite many years of conditioning. When these observations are taken together, it seems very unlikely that loss of fusion be the adequate stimulus for asymmetrical adaptation. Consistent fixation-disparities, even within the fusional range, present at saccadic offset, are a more probable candidate for such a stimulus. I would argue that fixation-disparity is a more direct stimulus, because of its relative simplicity, compared to fusion, or the loss of it, which involves higher visual processing.

Apart from the asymmetrical, adaptive changes in saccadic size, I found that the drift following a saccade was also adequately adapted, in the sense that the changes in velocity and direction reduced the vergence-deficit present at saccadic offset. These changes suggest that there was asymmetrical adaptation of both the pulse and the step which characterize the motor commands of saccades. However, these adaptive changes in post-saccadic drift were restricted to horizontal saccades. They were not observed in vertical saccades, nor in oblique saccades. In contrast, Erkelens et al. (1989b) did find such asymmetrical adaptive changes in post-saccadic drift for vertical saccades. I have no explanation for this discrepancy, other than idiosyncrasies. The fact remains, however, that plastic, asymmetrical changes in post-saccadic drift are not uniform for every meridian, which presumably reflects the different adaptive processes that take place in either one.

One might also argue that the asymmetrical, adaptive changes in post-saccadic drift resulted from adaptation of the vergence subsystem. If this were true, it would possibly explain why the plastic changes in post-saccadic drift were most prominent along the horizontal meridian, which is also the most effective meridian for vergence eye movements. Importantly, the asymmetrical changes in post-saccadic drift were also present during monocular viewing. This argues against the likelihood of the direct involvement of the vergence subsystem in the adaptive changes of post-saccadic drift, because the strongest stimulus for vergence movements, disparity (Erkelens and Regan, 1986), is absent during monocular viewing. A possible role of the vergence subsystem in the plastic changes of post-saccadic drift would therefore only be conceivable, if there were an adaptive linking between saccades and vergence eye movements. However, Erkelens et al. (1989b) tried to induce asymmetrical, adaptive changes in saccades by having subjects make, for half an hour at a stretch, repetitive gaze-shifts between two continuously present targets that differed both in direction and in distance. Despite this persistent coupling between version and vergence eye movements, no asymmetrical changes whatsoever occurred. Therefore, an adaptive linking between saccades and vergence eye movements is very unlikely. Taken together, the asymmetrical changes in post-saccadic drift to the wearing of anisometric spectacles do not seem to result from an adaptive modification of the vergence subsystem.

There is a marked contrast in the magnitude of the plastic changes in post-saccadic drift between adaptations to anisometric spectacles and adaptations to a unilateral, extraocular muscle weakness. In case of anisometric spectacles (Erkelens et al., 1989b; this thesis), the adaptive changes in post-saccadic drift are fairly inconspicuous as compared to the large changes associated with a paretic external eye muscle (Kommerell et al., 1976; Abel et al., 1978; Optican and Robinson, 1980; Snow et al., 1985; Optican et al., 1985; Viirre et al., 1988). This suggests that the plastic changes of saccades to these two different conditions may address very different stages of adaptive processing, although both conditions require an asymmetrical resetting of oculomotor commands to reduce the fixation-disparities at saccadic offset. Following a mechanical weakening of an external eye-muscle, conjugated saccades require different motor-commands for each of the two eyes. In case of a strictly visual pressure for asymmetrical adaptation, however, there is no physical damage to the oculomotor system. Therefore, conjugated saccades would not require a differential change in motor-commands between the two eyes. This conjugacy would then, however, be undesirable. Despite the possibility that a mechanical weakening of an external eye muscle elicits a fundamentally different adaptive response in the saccadic subsystem than a purely visual stimulus does, there is no conclusive evidence for this, except for the differences in post-saccadic drift between these two conditions. As post-saccadic drift may adapt independently of saccades (Optican and Miles, 1985), it might also be that the observed differences in post-saccadic drift result only from different adaptations of the post-saccadic drift per se, and not from different plastic changes of the entire programming of saccades.

There is another possible explanation for the large changes in post-saccadic drift associated with a weakened external eye-muscle, as compared to the moderate adaptive changes in post-saccadic drift related to the wearing of anisometric spectacles. In case of a pathological or experimental weakening of an external eye-muscle, the equilibrium between a pair of antagonistic muscles is disrupted. This will also be true for a weakening of both muscles, because the damage is unlikely to be equally severe for the agonist and the antagonist. It will be recalled that the pulse of the saccadic motor-commands brings the eye to a new position, whereas the step holds it in that position, thereby resisting the elastic forces which act on the globe, caused by the tissues which surround it. Therefore, if one or more external eye muscles are weakened, the same step-commands to each of the two eyes will lead to the occurrence of asymmetrical

post-saccadic drift. This would also occur when other asymmetrical changes within the orbit took place, such as changes in the elasticity of the tissues in which the eyeballs are suspended. If anisometric spectacles imposed a pressure for asymmetrical adaptation, however, the equilibrium between antagonistic muscle pairs would not be affected. This may explain the difference in the adaptive changes of post-saccadic drift between the wearing of anisometric spectacles and the weakening of one or more external eye-muscles.

From my study, and also from the work of others, the general picture emerges that adaptations of saccades will not differentiate any further than is specified by the stimulus. This will be illuminated in the following. Deubel et al. (1986) induced saccadic adaptation, using a target that jumped consistently in one direction during the execution of a saccade. This training was restricted to only one target amplitude. They found that the adaptive gain in saccadic size was transferred uniformly to saccades of different amplitudes, made in the same direction. Miller et al. (1981), who had performed similar experiments, had also found such a transfer, although it had not been as strong as in the experiments by Deubel et al. (1986). More recently, Deubel (1987) carried out experiments that were comparable to those in 1986. This time, however, he studied adaptation of saccades in various directions, including oblique saccades. Again, the stimulus for adaptation consisted of an intra-saccadic target displacement. He found transfer of these adaptations to adjacent directions, although this transfer was not very large. The important point is that this transfer occurred in default of any specific pressure for differential adaptation in those other, adjacent directions. A much stronger example of somewhat poor adaptive differentiation associated with a fairly nonspecific stimulus is that, in case of a unilateral, external eye-muscle weakness, saccades of both eyes will adapt in parallel when one eye is deprived of vision (Kommerell et al., 1976; Abel et al., 1978; Optican and Robinson, 1980; Optican et al., 1985). When vision is binocular, however, the adaptations of saccades to such a unilateral muscle weakness will be asymmetrical, i.e., differential for the two eyes (Snow et al., 1985; Viirre et al., 1988). My own work, presented in this thesis, as well as the work by Erkelens et al. (1989b), showed that similar, differential adaptations of saccades may also develop in response to specifically asymmetrical visual information. I even found that such asymmetrical adaptation could be induced selectively for various meridians, provided the stimulus was meridian-specific. Viirre et al. (1988) demonstrated an even higher level of differentiation



in asymmetrical adaptation: monkeys that had undergone surgical weakening of only one of the two horizontal recti muscles of one eye, and that were afterwards allowed binocular vision, showed asymmetrical adaptation that was direction-specific. Obviously, I was not able to induce similar asymmetrical adaptations in my experimental design, because spectacle-lenses do not differentiate between opposite directions, but only between meridians. In conclusion, saccadic adaptations will not differentiate further than the stimuli that induce them. This conclusion presumably applies to all sorts of sensory-motor plasticity.

Limits inherent in the adaptive processes of saccades may impose restrictions on the specificity of saccadic adaptations. Such restrictions, if any, appear to be by no means very tight: adaptations of saccades may be symmetrical (e.g. Kommerell et al., 1976; Abel et al., 1978; Deubel, 1987), but also differential for the two eyes (Snow et al., 1985; Erkelens et al., 1989b; this thesis). Such asymmetrical adaptations can also be specific for orthogonal meridians, even if these meridians are positioned obliquely ( Chapters 8 and 9). Furthermore, asymmetrical adaptations can be direction-specific (Viirre et al., 1988). An interesting question with this respect is how selective these kinds of saccadic adaptations can be for different amplitudes. Deubel et al. (1986) found a uniform transfer of the adaptive gain of horizontal saccades, established for one specific amplitude, to other horizontal saccades with different amplitudes. From this observation they inferred that adaptive changes of saccades consist of a uniform resetting of the gain of the pulse and the step of saccadic motor-commands. If this general resetting applied to all forms of saccadic plasticity, adaptations could not be amplitude-specific. There is, however, sufficient proof that argues against the likelihood of such a simple adaptive control strategy. First of all, the uniform transfer of adaptive gain to other amplitudes in the experiments by Deubel et al. (1986) occurred in the absence of a stimulus that was differential for the various saccadic amplitudes (Erkelens et al., 1989b). Moreover, the transfer that Miller et al. (1981) found in similar experiments was not uniform for all saccadic amplitudes. In my own experiments (Chapters 6 through 9), like those of Erkelens et al. (1989b) there was also no evidence for uniform adaptive changes over a range of saccadic magnitudes. Furthermore, the fact that saccadic adaptations can be asymmetrical, and moreover, meridian-specific or even direction-specific, make it highly improbable that the adaptive changes result from a simple resetting of a few global gain-parameters. Instead, the saccadic adaptations appear to take place on a point-to-point

basis in sensory-motor coordinates. Consequently, plastic changes of saccades could conceivably be highly selective for specific amplitudes, provided there were sufficient pressure for such adaptation. However, to my knowledge there is no literature that might substantiate this. By the same token, saccadic adaptations could presumably also differentiate accurately between closely spaced meridians or directions. The meridian-specificity that Deubel (1987) found for adapted saccades made in one direction was, without any pressure for different adaptations in adjacent directions, already quite good. It amounted to a specificity of about 30 deg to either side of that meridian. Again, with sufficient pressure this meridian-specificity might increase, although this has, to my knowledge, not been investigated. It is, however, questionable whether a higher meridian-specificity is necessary for the usual adaptations to the effects of growth, ageing and disease.

Another important observation by Deubel (1987) is that the adaptation he induced in oblique saccades could not result from individual adaptations of their horizontal and vertical components. My own data (Chapter 9), which relate specifically to asymmetrical adaptations of oblique saccades, confirm his finding. These results strongly suggest that the adaptive processes involved address an early stage in saccade generation, i.e., before decomposition of the central motor commands into their horizontal and vertical components. The model Deubel proposed of the direction-specific adaptations of saccades, would therefore have to be extended for asymmetrical saccadic adaptations.

Limitations of the adaptive processes also exist with respect to the magnitude of the adaptations. In my study, short-term asymmetrical adaptations to 8 D of anisometropia were not significantly different from the adaptations to 6 D of anisometropia (Chapter 7). I do not know if prolonged wearing of the 8 D anisometric spectacles would eventually have yielded larger asymmetries in saccadic size between the two eyes than with equally long adaptation to 6 D of anisometropia. My results comply, however, with the clinical rule of thumb that anisometropias larger than about 5 D are poorly tolerated. However, this poor tolerance does not necessarily have to be caused by limitations of the oculomotor system, but may also be due to limitations in perception, caused by the aniseikonia. Other examples of limited adaptations of the oculomotor system, frequently secondary to disease, are well-known in clinical practice (Leigh and Zee, 1983).

I found that asymmetrical adaptations were not only present in saccades, but also in smooth-pursuit eye movements. This raises the question if the two oculomotor subsystems involved, and possibly also other oculomotor subsystems, may share the same adaptive circuits. An obvious advantage of such a general adaptation would be efficiency. It would obviate the need to carry out virtually identical adaptive processes in every individual subsystem. On the other hand, a uniform plasticity for all subsystems would be undesirable if a more specific adaptive change were required. Such a specific change could be useful in case of, for instance, a very local lesion in one of the subsystems. In case of anisometric spectacles, however, there would be no need for differential adaptations for the various kinds of eye movements. Therefore, my experiments, in which presumably all kinds of eye movements were made during training, were not appropriate to distinguish between a general adaptation and multiple, individual adaptations. Such an assessment would, however, be very interesting.

I showed that asymmetrical adaptations may develop very rapidly. After only 1 hour of conditioning to anisometric spectacles, the adaptation was almost complete for a moderate pressure and well under way for fairly large pressures (Chapter 7). Symmetrical adaptations of saccades to intra-saccadic target displacements can also take place very rapidly (Miller et al., 1981; Deubel et al. 1986; Deubel, 1987). The speed of all these adaptive changes illustrates once more how remarkably flexible the saccadic subsystem, as well as the smooth-pursuit subsystem, is in dealing with pressure for change. This flexibility is probably essential to the sustained and proper functioning of the oculomotor system throughout a lifetime. Another conspicuous example of how quickly saccades and smooth-pursuit eye movements may adapt was my demonstration of a subject who was used to wearing his anisometric spectacles for only several hours a day (Chapter 6). When he wore them, he was asymmetrically adapted, even when one eye was covered, and when he took them off, his eye movements were normally yoked. It seems very unlikely that he has to readapt from scratch every time he puts his spectacles on or takes them off again. Rather, these results suggest that the plastic changes may be stored in various modalities, each of which can be rapidly called upon when necessary. This confirms my belief that the specificity of adaptations, both spatial and temporal, is specified by the demands of the stimulus.



## REFERENCES

- Abel L.A., Schmidt D., Dell'Osso L.F. and Daroff R.B. (1978). Saccadic system plasticity in humans. *Ann. Neurol.*, 4, 313-318.
- Allen D.C. (1974). Vertical prism adaptation in anisometropes. *Amer. J. Optom. Physiol. Opt.*, 51, 252-259.
- Bahill T.A., Clark M.R. and Stark L. (1975a). The main sequence, a tool for studying human eye movements. *Math. Biosci.*, 24, 191-204.
- Bahill T.A., Clark M.R. and Stark L. (1975b). Dynamic overshoot in saccadic eye movements is caused by neurological control signal reversals. *Exp. Neurol.*, 48, 107-122.
- Becker W. (1972). The control of eye movements in the saccadic system. *Bibl. Ophthalmol.*, 82, 233-243.
- Becker W. (1976). Do correction saccades depend exclusively on retinal feedback? A note on the possible role of non-retinal feedback. *Vision Res.*, 16, 425-427.
- Becker W. and Fuchs A.F. (1969). Further properties of the human saccadic system: eye movements and correction saccades with and without visual fixation points. *Vision Res.*, 9, 1247-1258.
- Becker W. and Jürgens R. (1979). An analysis of the saccadic system by means of double step stimuli. *Vision Res.*, 19, 967-983.
- Bennett A.G. and Francis J.L. (1962). Ametropia and its correction. In: Davson H. (ed.). *The eye, volume 4. Visual optics and the optical space sense*. Academic Press, London. pp. 133-180.
- Berthoz A. and Melvill Jones G. (eds) (1985). *Adaptive mechanisms in gaze control. Facts and theories*. Elsevier, Amsterdam, New York, Oxford.
- Boghen D., Troost B.T., Daroff R.B., Dell'Osso L.F. and Birkett J.E. (1974). Velocity characteristics of normal human saccades. *Invest. Ophthalmol.*, 13, 619-623.
- Bridgeman B. (1977). In: Bridgeman B. and Stark L. (eds). *The theory of binocular vision*. Translation of Hering E. (1868): *Die Lehre vom Binokularen Sehen*. Plenum Press, New York.
- Büttner U., Büttner-Ennever J.A. and Henn V. (1977). Vertical eye movement related unit activity in the rostral mesencephalic reticular formation of the alert monkey. *Brain Res.*, 130, 239-252.
- Carpenter R.H.S. (1988). *Movements of the eyes*. Pion, London.
- Collewijn H., Mark F. Van der and Jansen T.C. (1975). Precise recording of human eye movements. *Vision Res.*, 15, 447-450.
- Collewijn H., Martins A.J. and Steinman R.M. (1981). Natural retinal image motion: origin and change. *Ann. NY Acad. Sci.*, 374, 312-329.

- Collewijn H., Martins A.J. and Steinman R.M. (1983). Compensatory eye movements during active and passive head movements: fast adaptation to changes in visual magnification. *J. Physiol.*, 340, 259-286.
- Collewijn H., Steen J. Van der and Steinman R.M. (1985). Human eye movements associated with blinks and prolonged eyelid closure. *J. Neurophysiol.*, 54, 11-27.
- Collewijn H., Erkelens C.J. and Steinman R.M. (1988a). Binocular co-ordination of human horizontal saccadic eye movements. *J. Physiol.*, 404, 157-182.
- Collewijn H., Erkelens C.J. and Steinman R.M. (1988b). Binocular co-ordination of human vertical saccadic eye movements. *J. Physiol.*, 404, 183-197.
- Collewijn H., Erkelens C.J. and Steinman R.M. (1988c). Undoing Hering's law: differential adaptation of saccadic amplitude in the two eyes. *Invest. Ophthalmol. Vis. Sci.*, 29, p. 166 (abstract 8).
- Deubel H. (1987). Adaptivity of gain and direction in oblique saccades. In: O'Regan J.K. and Lévy-Schoen A. (eds). *Eye Movements: from Physiology to cognition*. Elsevier, Amsterdam. pp. 181-190.
- Deubel H., Wolf W. and Hauske G. (1982). Corrective saccades: effect of shifting the saccade goal. *Vision Res.*, 22, 353-364.
- Deubel H., Wolf W. and Hauske G. (1986). Adaptive gain control of saccadic eye movements. *Human Neurobiol.*, 5, 245-253.
- Dodge R. (1903). Five types of eye movement in the horizontal meridian plane of the field of regard. *Am. J. Physiol.*, 8, 307-329.
- Ellerbrock V.J. (1948). Further study of effects induced by anisometric corrections. *Am. J. Optom. Arch. Am. Acad. Optom.*, 25, 430-437.
- Enright J.T. (1984). Changes in vergence mediated by saccades. *J. Physiol.*, 350, 9-31.
- Enright J.T. (1986). Facilitation of vergence changes by saccades: influences of misfocused images and of disparity stimuli in man. *J. Physiol.*, 371, 69-87.
- Erkelens C.J. (1988). Fusional limits for a large random-dot stereogram. *Vision Res.*, 28, 345-353.
- Erkelens C.J. and Regan D. (1986). Human ocular vergence movements induced by changing size and disparity. *J. Physiol.*, 379, 145-169.
- Erkelens C.J., Steinman R.M. and Collewijn H. (1989a). Ocular vergence under natural conditions. II. Gaze shifts between real targets differing in distance and direction. *Proc. R. Soc. Lond.*, B 236, 441-465.
- Erkelens C.J., Collewijn H. and Steinman R.M. (1989b). Asymmetrical adaptation of human saccades to anisometric spectacles. *Invest. Ophthalmol. Vis. Sci.*, 30, 1132-1145.
- Fender D. and Julesz B. (1967). Extension of Panum's fusional area in binocularly stabilized vision. *J. Opt. Soc. Am.*, 57, 819-830.

- Fuchs A.F., Kaneko C.R.S. and Scudder C.A.** (1985). Brainstem control of saccadic eye movements. *Ann. Rev. Neurosci.*, 8, 307-337.
- Gisbergen J.A.M. Van, Opstal A.J. Van and Schoenmakers J.J.M.** (1985). Experimental test of two models for the generation of oblique saccades. *Exp. Brain Res.*, 57, 321-336.
- Gisbergen J.A.M. Van, Opstal A.J. Van and Roebroek J.G.H.** (1987). Stimulus-induced midflight modification of saccade trajectories. In: O'Regan J.K. and Lévy-Schoen (eds). *Eye Movements: from Physiology to cognition*. Elsevier, Amsterdam. pp. 27-36.
- Grossman G.E. and Robinson D.A.** (1988). Ambivalence in modelling oblique saccades. *Biol. Cybern.*, 58, 13-18.
- Haddad G.M. and Steinman R.M.** (1973). The smallest voluntary saccade: implications for fixation. *Vision Res.*, 13, 1075-1086.
- Hallett P.E. and Lightstone A.D.** (1976). Saccadic eye movements to flashed targets. *Vision Res.*, 16, 107-114.
- Helmholtz H.L.F. Von** (1867). Movements of the eyes. In: *Helmholtz's treatise on physiological optics* (translated from the third German edition and edited by Southall J.P.C. (1962). Vol.III. Dover Publications Inc., New York. pp. 37-126.
- Henn V. and Cohen B.** (1976). Coding of information about rapid eye movements in the pontine reticular formation of alert monkeys. *Brain Res.*, 108, 307-325.
- Henson D.B.** (1979). Investigation into corrective saccadic eye movements for refixation amplitudes of 10 degrees and below. *Vision Res.*, 19, 57-61.
- Henson D.B. and Dharamshi B.G.** (1982). Oculomotor adaptation to induced heterophoria and anisometropia. *Invest. Ophthalmol. Vis. Sci.*, 22, 234-240.
- Henson D.B. and North R.E.** (1980). Adaptation to prism-induced heterophoria. *Am. J. Optom. Physiol. Opt.*, 57, 129.
- Hepp K. and Henn V.** (1983). Spatio-temporal recoding of rapid eye movement signals in the monkey paramedian pontine reticular formation (PPRF). *Exp. Brain Res.*, 52, 105-120.
- Hering E.** (1868). Die Lehre vom binokularen Sehen. English translation in: Bridgeman B. and Stark L. (eds) (1977). *The theory of binocular vision*. Plenum Press, New York.
- Horner D.G., Gleason G. and Schor C.M.** (1988). The recalibration of Hering's law for versional eye movements in response to aniseikonia. *Invest. Ophthalmol. Vis. Sci.*, 29, p. 136 (abstract 28).
- Kapoula Z., Hain T.C., Zee D.S. and Robinson D.A.** (1987). Adaptive changes in post-saccadic drift induced by patching one eye. *Vision Res.*, 27, 1299-1307.
- Kapoula Z. and Robinson D.A.** (1986). Saccadic undershoot is not inevitable: saccades can be accurate. *Vision Res.*, 26, 735-743.

- Kapoula Z.A., Robinson D.A. and Hain T.C.** (1986). Motion of the eye immediately after a saccade. *Exp. Brain Res.*, 61, 386-394.
- Keller E.L.** (1974). Participation of medial pontine reticular formation in eye movement generation in monkey. *J. Neurophysiol.*, 37, 316-332.
- King W.M., Lisberger S.G. and Fuchs A.F.** (1986). Oblique saccadic eye movements of primates. *J. Neurophysiol.*, 56, 769-784.
- Kommerell G., Olivier D. and Theopold H.** (1976). Adaptive programming of phasic and tonic components in saccadic eye movements. Investigations in patients with abducens palsy. *Invest. Ophthalmol.*, 15, 657-660.
- Kowler E., Martins A.J. and Pavel M.** (1984). The effect of expectations on slow oculomotor control - IV. Anticipatory smooth eye movements depend on prior target motions. *Vision Res.*, 24, 197-210.
- Kowler E. and Steinman R.M.** (1979a). The effect of expectations on slow oculomotor control - I. Periodic target steps. *Vision Res.*, 19, 619-632.
- Kowler E. and Steinman R.M.** (1979b). The effect of expectations on slow oculomotor control - II. Single target displacements. *Vision Res.*, 19, 633-646.
- Kowler E. and Steinman R.M.** (1981). The effect of expectations on slow oculomotor control - III. Guessing unpredictable target displacements. *Vision Res.*, 21, 191-203.
- Lauritis V.P. and Robinson D.A.** (1986). The vestibulo-ocular reflex during human saccadic eye movements. *J. Physiol.*, 373, 209-233.
- Leigh R.J. and Zee D.S.** (1983). *The neurology of eye movement*. F.A. Davis Company, Philadelphia.
- Lemij H.G. and Collewijn H.** (1989). Differences in accuracy of human saccades between stationary and jumping targets. *Vision Res.* (in press).
- Lemij H.G., Erkelens C.J. and Collewijn H.** (1988). Do common experimental conditions impair saccadic eye movements? *Europ. J. Neurosc. Suppl.*, supplement, p. 6, (abstract 6.4).
- Levi L., Zee D.S., Hain T.C., Fletcher W.A. and Miller N.R.** (1988). Ocular motor adaptation to anisometropic correction. *Invest. Ophthalmol. Vis. Sci.*, 29, p. 167 (abstract 14).
- Luschei E.S. and Fuchs A.F.** (1972). Activity of brain stem neurons during eye movements of alert monkeys. *J. Neurophysiol.*, 35, 445-461.
- Miller J.M., Anstis T. and Templeton W.B.** (1981). Saccadic plasticity: parametric adaptive control by retinal feedback. *J. Exp. Psychol. (Human Percept.)*, 7, 356-366.
- Ogle K.N.** (1962). Special topics in binocular spatial localization. In: Davson H. (ed.). *The eye, volume 4. Visual optics and the optical space sense*. Academic Press, London. pp. 349-407.
- Ono H.** (1980). Hering's law of equal innervation and vergence eye movement. *Am. J. Optom. Physiol. Opt.*, 57, 578-585.



- Ono H. and Nakamizo S.** (1978). Changing fixation in the transverse plane at eye level and Hering's law of equal innervation. *Vision Res.*, 18, 511-519.
- Ono H., Nakamizo S. and Steinbach M.J.** (1978). Nonadditivity of vergence and saccadic eye movement. *Vision Res.*, 18, 735-739.
- Opstal A.J. Van and Gisbergen J.A.M. Van** (1989). Saccade-endpoint scatter and properties of the collicular motor map. *Vision Res.*, (in press).
- Optican L.M.** (1985). Adaptive properties of the saccadic system. In: Berthoz A. and Melvill Jones G. (eds). *Adaptive mechanisms in gaze control. Facts and theories*. Elsevier, Amsterdam, New York, Oxford. pp. 71-80.
- Optican L.M. and Miles F.A.** (1985). Visually induced adaptive changes in primate saccadic oculomotor control signals. *J. Neurophysiol.*, 54, 940-958.
- Optican L.M. and Robinson D.A.** (1980). Cerebellar-dependent adaptive control of primate saccadic system. *J. Neurophysiol.*, 44, 1058-1076.
- Optican L.M., Zee D.S. and Chu F.C.** (1985). Adaptive response to ocular muscle weakness in human pursuit and saccadic eye movements. *J. Neurophysiol.*, 54, 110-122.
- Pelisson D. and Prablanc C.** (1988). Kinematics of centrifugal and centripetal saccadic eye movements. *Vision Res.*, 28, 87-94.
- Piantanida T.P.** (1986). Stereo hysteresis revisited. *Vision Res.*, 26, 431-437.
- Prablanc C. and Jeannerod M.** (1975). Corrective saccades: dependence on retinal reafferent signals. *Vision Res.*, 15, 465-469.
- Robinson D.A.** (1963). A method of measuring eye movements using a scleral search coil in a magnetic field. *IEEE Trans. Biomed. Electron.*, BME-10, 137-145.
- Robinson D.A.** (1964). The mechanics of human saccadic eye movement. *J. Physiol.*, 174, 245-264.
- Robinson D.A.** (1975). Oculomotor control signals. In: Lennerstrand G. and Bach-y-Rita P. (eds). *Basic mechanisms of ocular motility and their clinical implications*. Pergamon, Oxford. pp. 337-374.
- Schor C.M., Gleason G. and Horner D.G.** (1988). The variability and adaptability of Hering's law for yoked reflexive eye movements. *Invest. Ophthalmol. Vis. Sci.*, 29, p. 136 (abstract 27).
- Snow R., Hore J. and Vilis T.** (1985). Adaptation of saccadic and vestibulo-ocular systems after extraocular muscle tenectomy. *Invest. Ophthalmol. Vis. Sci.*, 26, 924-931.
- Southall J.P.C.** (1937). *Introduction to physiological optics*. Newly published in 1961, Dover Publications, New York.
- Sparks D.L., Mays L.E. and Porter J.D.** (1987). Eye movements induced by pontine stimulation: interaction with visually triggered saccades. *J. Neurophysiol.*, 58, 300-318.

- Tweed D. and Vilis T.** (1985). A two dimensional model for saccade generation. *Biol. Cybern.*, 52, 219-227.
- Tweed D. and Vilis T.** (1987). Implications of rotational kinematics for the oculomotor system in three dimensions. *J. Neurophysiol.*, 58, 832-849.
- Viirre E., Cadera W. and Vilis T.** (1987). The pattern of changes produced in the saccadic system and vestibulo-ocular reflex by visually patching one eye. *J. Neurophysiol.*, 57, 92-103.
- Viirre E., Cadera W. and Vilis T.** (1988). Monocular adaptation of the saccadic system and vestibulo-ocular reflex. *Invest. Ophthalmol. Vis. Sci.*, 29, 1339-1347.
- Vilis T. and Hore J.** (1981). Characteristics of saccadic dysmetria in monkeys during reversible lesions of medial cerebellar nuclei. *J. Neurophysiol.*, 46, 828-838.
- Vilis T., Yates S. and Hore J.** (1983) Cerebellar saccadic dysmetria is not equal in the two eyes. *Exp. Brain Res.*, 51, 343-350.
- Vilis T., Yates S. and Hore J.** (1985). Visual patching of one eye produces changes in saccadic properties in the unseeing eye. *Dev. Brain Res.*, 17, 290-292.
- Weber R.B. and Daroff R.B.** (1971). The metrics of horizontal saccadic eye movements in normal humans. *Vision Res.*, 11, 921-928.
- Weber R.B. and Daroff R.B.** (1972). Corrective movements following refixation saccades: type and control system analysis. *Vision Res.*, 12, 467-475.
- Westheimer G.** (1954). Eye movement responses to a horizontally moving visual stimulus. *AMA Arch. Ophthalmol.*, 52, 932-941.
- Yarbus A.L.** (1967). *Eye movements and vision*. Plenum Press, New York.
- Zingale C.M. and Kowler E.** (1987). Planning sequences of saccades. *Vision Res.*, 27, 1327-1341.

## SUMMARY

Saccades are the rapid eye movements which enable us to voluntarily shift our gaze from one visual target to another. They serve to bring newly selected visual targets to the fovea of each of the two eyes, which is a small part of the retina with high visual acuity. This accurate, binocular control of saccades requires a high quality of oculomotor coordination. During the course of a lifetime, the various structures involved in the generation and the control of saccades may be subject to change, due to, for example, growth, ageing, disease or injury. These changes will undoubtedly affect saccadic control, and, consequently, jeopardize its quality. To safeguard its proper functioning, the oculomotor system will therefore have to adapt adequately to such changes. As these changes probably take place haphazardly, at different places, with different time-courses and with different degrees of severity, the saccadic subsystem should be capable of adapting specifically to such non-uniform changes. Adaptation of saccades has been described in the literature subsequent to local, physical damage to external eye muscles, as well as to purely visual stimuli (for a review, see Chapter 2). The aim of this thesis was to assess both qualitatively and quantitatively how the saccadic subsystem responds to a consistent visual pressure for an asymmetrical adaptation, i.e., adaptation that is different for each of the two eyes.

It is generally assumed that the two eyes make saccades of the same size. This assumption is frequently referred to as Hering's law of equal innervation (Hering's law is commented on in Chapter 2). Normally, such yoking of the eyes is desirable. However, this will not be the case when a subject wears so-called anisometric spectacles. These are spectacles which have lenses with different refractive powers, and therefore different magnifications. As a result of these different magnifications, the visual images will be differently sized in each of the two eyes. Consequently, the saccades of the two eyes would, ideally, also have to be different in magnitude (Chapter 6). In the present thesis I have demonstrated that saccades may indeed adapt to anisometric spectacles in such a way that they become different in size. This result will shortly be discussed in greater detail.

Measuring eye movements, and especially, comparing those of the two eyes with each other, requires a clear convention for describing eye-positions. The most convenient coordinate system for that purpose is the one named after Helmholtz. Therefore, special equations were derived to transform the recorded eye-positions into Helmholtz's coordinates. Eye movements were recorded binocularly by means of magnetic sensor coils, which allow a very accurate and precise recording over a wide range. Because two other coordinate systems are also commonly used to describe eye-positions (those of Fick and of Listing), additional equations were derived for the transformation of the coordinates of one system into the other. Furthermore, a special calibration procedure, as well as a linearization technique of the recordings were developed (Chapter 3). As the difference in size between saccades of the two eyes was used as a measure of asymmetrical adaptation, care was taken that the positions of the visual targets used provided no stimulus for disjunctive eye movements. To that end a special screen onto which the targets were later projected was constructed. This screen had a toroid, iso-vergence surface. The basic principles of this screen were explained in Chapter 3. Other details on the materials I used and the methods I employed were also discussed in Chapter 3.

Before asymmetrical adaptations to the wearing of anisometric spectacles were studied, I examined the accuracy of unadapted saccades (Chapter 4). It is usually assumed that saccades fall short of their target by about 10% of the angular distance between the previous and the new target. This position error at saccadic offset is then compensated by secondary saccades. These results relate to experimental conditions in which the saccades are elicited by a target that jumps, flashes, suddenly disappears or reappears. Such conditions very poorly resemble real-life circumstances, in which saccades are predominantly made to continuously present, stationary targets. I compared the accuracy of saccades made between two stationary targets that were continuously present, to the accuracy of saccades that were elicited by a single, regularly jumping target. The saccadic accuracy was two- to five-fold better with stationary targets than with a jumping target. Correspondingly, the number of secondary saccades was significantly reduced with stationary targets.

As a next step, baseline data were obtained on the yoking of normal saccades in Chapter 5, for comparison with the yoking of asymmetrically adapted saccades. It turned out that

even normal, unadapted horizontal saccades were not perfectly yoked. Abducting saccades were slightly larger than the saccades of the fellow, adducting eye. This difference was about 0.3 deg. In addition, when one eye was covered, it made saccades that were approximately 0.3 deg smaller than the contralateral, viewing eye. Vertical saccades were more conjugate than horizontal saccades. Post-saccadic drift of horizontal saccades was also not perfectly yoked. These asymmetries in concomitant saccades were, however, negligible to the asymmetries that might be observed in saccades, adapted to anisometric spectacles (Chapters 6 through 9).

In Chapter 6, long-term asymmetrical adaptations of saccades were studied in habitual anisometric spectacle-wearers. Differences in saccadic size between the two eyes could be as large as about 10% of the target amplitude. The adaptations were almost complete during binocular viewing. The degree of asymmetrical adaptation varied, however, within each subject, for the various saccadic amplitudes and also for the two meridians (horizontal and vertical). From this it was concluded that the adaptations did not result from a simple resetting of a few global parameters in the generation of saccadic motor-commands, as has been proposed as a general strategy of the saccadic subsystem to adapt. Instead, the adaptive changes appear to be based upon a point-to-point readjustment of sensory-motor coordinates. Further support for such a point-to-point, adaptive modification of motor commands was provided by the results of the next chapters. Importantly, the adaptive asymmetries in saccadic size were also present during monocular viewing, although to a slightly lesser extent, which showed that the adaptations were hard-programmed, because they did not result from direct, asymmetrical visual input. Post-saccadic drift of horizontal saccades was also asymmetrically adapted, in the sense that it reduced the vergence-deficit present at saccadic offset. Post-saccadic drift associated with vertical saccades was not significantly changed. In addition, the asymmetrical adaptations were also present in smooth-pursuit eye movements.

In Chapter 7, I examined the time-course and the limits of these asymmetrical adaptations of horizontal and vertical saccades to the short-term wearing of anisometric spectacles. After only 1 hour of conditioning to a moderate pressure (2 D of anisometropia), the asymmetrical adaptations were almost complete along one meridian. For larger pressures, the adaptations were well under way. These results

demonstrated how rapidly such adaptive changes may develop. An anisometropia larger than 6 D did not further increase the rate of adaptation during the first 6 hours of conditioning, which suggests that about 6 D may be the upper limit of what can be handled by the adaptivity of the saccadic subsystem. Post-saccadic drift of horizontal saccades was also adequately changed. In addition, asymmetrical adaptations had also developed in smooth-pursuit eye movements. All these plastic changes persisted during monocular viewing, indicating that the basic programming of these eye movements was changed. Just as with long-term adaptations, the plastic changes could not be explained by a uniform resetting of a few, uniform parameters in the oculomotor commands.

In Chapter 8, I determined whether such asymmetrical adaptations might be specific for the horizontal or the vertical meridian. Such a plastic capacity of the oculomotor system would greatly add to its flexibility to adequately adapt to various stimuli. To that end subjects adapted to anisometric spectacles that contained a negative, cylindrical lens (-3 D) on one side, and no lens on the other side. Such a lens reduces the visual image along one meridian only. With the lens-axis positioned vertically, asymmetrical adaptations of saccades, and also of smooth-pursuit eye movements, developed along the appropriate, horizontal meridian only. The same applied to the post-saccadic drift. Vertical saccades remained unchanged. Again, the adaptations were hard-programmed. When the experiment was repeated on another day, this time with the lens-axis positioned horizontally, only vertical asymmetries were induced. Post-saccadic drift of vertical saccades was, however, unaffected.

In Chapter 9, I addressed the question whether asymmetrical adaptations could be specific for any meridian, also oblique meridians, or whether asymmetrical adaptations of oblique saccades would merely consist of an adaptive change of their individual horizontal and vertical components. In that case, the adaptations would not be specific for oblique meridians. This was examined by means of a cylindrical spectacle-lens, just as in Chapter 8, supplied to one eye for 7 continuous hours. In the present experiments, however, the lens-axis was positioned obliquely. After the training-period, asymmetrical adaptations of saccades, and also of smooth-pursuit eye movements, had developed, that were truly specific for the appropriate, oblique meridian. This shows that the asymmetrical adaptations take place before the central command to generate an oblique saccade is decomposed into its horizontal and vertical components.

All these experiments demonstrate the remarkable capacity of the oculomotor system to adapt adequately to various kinds of specific, visual pressure. This capacity may help to maintain proper oculomotor control throughout a lifetime.





## SAMENVATTING

Saccades zijn snelle oogbewegingen waarmee wij onze blik willekeurig van het ene visuele doel naar het andere kunnen verplaatsen. Zij dienen om het beeld van het nieuwe visuele doel op een klein deel van het netvlies te laten vallen waar de gezichtsscherpte groot is. Dit deel heet de fovea. Dit proces vindt voor beide ogen bijzonder nauwkeurig plaats, hetgeen hoge eisen stelt aan de sturing van saccades. In alle structuren die betrokken zijn bij die sturing kunnen er gedurende ons leven veranderingen optreden als gevolg van bijvoorbeeld groei, veroudering en ziekte. Deze veranderingen hebben ongetwijfeld gevolgen voor de sturing van saccades en vormen daarom mogelijk een bedreiging voor de kwaliteit ervan. Om die kwaliteit te bewaken, dient het saccade-systeem zich daarom adequaat aan te passen aan dergelijke veranderingen. Aangezien deze veranderingen waarschijnlijk lukraak op verschillende plaatsen optreden, verschillende tijdsverlopen hebben en in intensiteit wisselen, dienen de aanpassingen van het saccade-systeem specifiek te zijn voor dergelijke niet-uniforme veranderingen. Adaptatie van saccades is beschreven voor verschillende soorten veranderingen; zowel voor beschadiging van uitwendige oogspieren, alsmede voor puur visuele prikkels (voor een overzicht, zie Hoofdstuk 2). De opzet van dit proefschrift was om na te gaan hoe het saccade-systeem reageert op een consistente visuele prikkel die vereist dat de twee ogen zich verschillend, dat wil zeggen *asymmetrisch*, aanpassen.

Algemeen wordt aangenomen dat de twee ogen normaliter saccades maken van gelijke grootte, hetgeen is vastgelegd in de wet van Hering, die stelt dat de twee ogen een gelijke innervatie ontvangen (de wet van Hering wordt in Hoofdstuk 2 besproken). Normaliter is een dergelijk conjugaat bewegen van de ogen wenselijk. Dat is echter niet het geval wanneer men een zogenaamd anisometrope bril draagt; dat is een bril waarvan de twee glazen een verschillende brekingssterkte hebben. Hierdoor krijgen de visuele beelden in elk oog een verschillende grootte, waardoor de saccades voor elk oog ook van ongelijke grootte dienen te zijn. In dit proefschrift heb ik aangetoond dat een dergelijke aanpassing van saccades aan anisometrope brillen inderdaad mogelijk is.

Om oogbewegingen te meten en die van de twee ogen met elkaar te vergelijken, dient men oogposities ondubbelzinnig te beschrijven. Het coördinaatsysteem volgens Helmholtz

leent zich hier het beste voor. Derhalve heb ik goniometrische vergelijkingen afgeleid die de gemeten oogposities omzetten in Helmholtz-coördinaten. Aangezien twee andere coördinaatsystemen (genoemd naar Fick en naar Listing) ook veelvuldig gebruikt worden, heb ik formules afgeleid, waarmee de coördinaten van elk systeem in die van de ander kunnen worden omgezet. Daarnaast heb ik een speciale ijkingsprocedure en een linearisatie-techniek ontwikkeld (Hoofdstuk 3). Oogbewegingen werden nauwkeurig en binoculair gemeten door middel van magnetische inductie-spoeltjes. Omdat het verschil in grootte van saccades tussen de twee ogen gebruikt werd als maat voor asymmetrische adaptatie, heb ik ervoor gezorgd dat de posities van de visuele doelen op zich geen prikkel vormden voor niet-conjugate oogbewegingen. Daartoe heb ik een speciaal scherm geconstrueerd, waarop de doelen later geprojecteerd werden. De principes van dit scherm worden toegelicht in Hoofdstuk 3. De overige methoden en technieken die ik heb toegepast, worden eveneens in Hoofdstuk 3 besproken.

Alvorens asymmetrische adaptaties aan anisometrope brillen te bestuderen, heb ik de nauwkeurigheid van ongeadapteerde saccades onderzocht (Hoofdstuk 4). Algemeen wordt aangenomen dat saccades ongeveer 10% te klein zijn voor de te overbruggen afstand. De positie-fout die daardoor ontstaat aan het eind van elke saccade, wordt vervolgens gecompenseerd door secundaire saccades. Deze gegevens zijn ontleend aan experimenten, waarbij visuele doelen werden gebruikt, die versprongen of flitsten, of anderszins discontinu aanwezig waren. Dergelijke experimentele condities vertonen echter weinig gelijkenis met normale, dagelijkse omstandigheden, waarin wij voornamelijk saccades maken naar stilstaande, continu aanwezige doelen. Ik heb de nauwkeurigheid vergeleken van saccades die gemaakt werden tussen stationaire, continu aanwezige doelen met die van saccades die opgewekt werden door een verspringend doel. De nauwkeurigheid was twee tot vijf maal beter met stilstaande doelen dan met een verspringend doel. In overeenstemming hiermee, was het aantal secundaire saccades bij stilstaande doelen significant kleiner.

Bij verdere analyse van ongeadapteerde saccades bleek dat zelfs normale saccades niet geheel conjugaat zijn (Hoofdstuk 5). Abducerende saccades zijn ongeveer 0,3 graden groter dan die van het adducenterende, contralaterale oog. Bovendien zijn de saccades van een afgedekt oog ongeveer 0,3 graden kleiner dan die van het ziende oog. Verticale saccades waren meer geconjugeerd dan horizontale saccades. Aan het eind van een

saccade maken de ogen vaak een langzame, gladde beweging: post-saccadische drift. De post-saccadische drift van horizontale saccades bleek ook niet volkomen conjugaat. Al deze asymmetrieën waren echter verwaarloosbaar in vergelijking met de asymmetrieën die konden optreden na adaptatie aan anisometrope brillen (Hoofdstuk 6 tot en met 9).

In Hoofdstuk 6 heb ik asymmetrische adaptaties bestudeerd bij mensen die reeds vele jaren anisometrope brillen droegen. Verschillen in saccade-afmeting tussen de twee ogen konden een grootte bereiken van ongeveer 10% van de doel-amplitude (de doel-amplitude is de afstand tussen twee visuele doelen, uitgedrukt in graden). Tijdens binoculair zien waren de adaptaties vrijwel volledig. De mate van adaptatie varieerde echter per proefpersoon voor de verschillende doel-amplitudes en ook voor de twee meridianen (horizontaal en verticaal). Hieruit valt af te leiden dat een dergelijke adaptatie niet bestaat uit een eenvoudige modificatie van enkele algemene parameters in de opwekking van de saccade motor-commando's, zoals wel is gesuggereerd voor adaptaties van saccades in het algemeen. Mijn resultaten wijzen erop dat adaptatie plaatsvindt op basis van een punt-tot-punt aanpassing van sensori-motore coördinaten. Resultaten uit volgende hoofdstukken bevestigen dit. Van groot belang is dat de asymmetrische adaptaties ook aanwezig waren wanneer een oog was afgedekt, hetgeen impliceert dat de adaptaties "hard" waren, omdat zij in deze conditie niet het gevolg konden zijn van directe, asymmetrische visuele informatie. Post-saccadische drift van horizontale saccades was eveneens asymmetrisch geadapteerd, in die zin dat de drift steeds bijdroeg aan het elimineren van positiefouten die resteerden na de saccade. Bovendien bleken de asymmetrische adaptaties ook opgetreden te zijn in gladde volgbewegingen.

In Hoofdstuk 7 bekeek ik het tijdsverloop en de grenzen van dergelijke asymmetrische adaptaties gedurende de eerste uren dat anisometrope brillen gedragen werden. Na slechts 1 uur blootstelling aan een anisotropie van 2 D was de adaptatie vrijwel volledig voor één meridiaan. Bij grotere anisotropieën waren de adaptaties nog niet compleet, maar reeds aanzienlijk toegenomen. Deze resultaten tonen hoe snel dergelijke adaptaties kunnen optreden. Mijn resultaten suggereren bovendien dat 6 D anisotropie de bovengrens vormt van wat het saccade-systeem aankan. Post-saccadische drift van horizontale saccades was eveneens adequaat geadapteerd. Dit gold ook voor gladde volgbewegingen. Al deze plastische veranderingen waren ook aanwezig

tijdens monoclair zien, hetgeen aangeeft dat zij geïncorporeerd waren in de basale programmering van saccades en gladde volgbewegingen.

Vervolgens heb ik onderzocht of asymmetrische adaptaties specifiek kunnen zijn voor de horizontale of verticale meridiaan (Hoofdstuk 8). Een dergelijke specificiteit zou de flexibiliteit van adaptatie-processen ten goede komen. Voor dit onderzoek gebruikte ik een negatieve, cilindrische lens (-3 D), die gedurende 7 uren continu voor het rechter oog gedragen werd. Een dergelijke lens verkleint het visuele beeld slechts langs één meridiaan. Het bleek mogelijk asymmetrische adaptaties te bewerkstelligen, die specifiek waren voor hetzij de horizontale meridiaan, hetzij de verticale meridiaan, afhankelijk van de positie van de lens-as. Post-saccadische drift van horizontale saccades, alsmede gladde volgbewegingen bleken eveneens meridiaan-specifiek geadapteerd te kunnen worden.

Tot slot heb ik in Hoofdstuk 9 onderzocht of asymmetrische adaptaties ook opgewekt kunnen worden voor iedere willekeurige meridiaan, schuine meridianen inbegrepen, of dat adaptaties van schuine saccades plaatsvinden op grond van individuele adaptaties van hun horizontale en verticale componenten. Dit werd bekeken met gebruikmaking van dezelfde lens als in Hoofdstuk 8. Ditmaal werd de lens-as echter schuin geplaatst. Na 7 uur waren asymmetrische adaptaties geïnduceerd die inderdaad specifiek waren voor de juiste, schuine meridiaan. Dit gold zowel voor saccades als voor gladde volgbewegingen. Deze resultaten tonen dat de asymmetrische adaptaties plaatsvinden voordat de motor-commando's voor schuine saccades worden ontbonden in hun individuele horizontale en verticale componenten.

Al deze resultaten geven aan hoe fraai het oogbewegings-systeem uitgerust is om zich adequaat aan te passen aan verschillende vormen van specifieke, visuele druk. Deze eigenschap kan bijdragen tot het blijvend goed functioneren van onze oogbewegingen gedurende een heel leven.

## CURRICULUM VITAE

De auteur werd op 14 juli 1960 geboren in Point Fortin (Trinidad). In 1978 behaalde hij het eindexamen Atheneum B op het Rijnlands Lyceum te Wassenaar. Aansluitend studeerde hij Geneeskunde aan de Rijksuniversiteit te Leiden. In 1985 slaagde hij voor het artsexamen (cum laude). Het grootste deel van zijn militaire diensttijd bij de Koninklijke Marine was hij werkzaam als assistent Psychiatrie in het Marine Hospitaal te Overveen. In maart 1987 werd hij aangesteld als wetenschappelijk onderzoeker bij de Stichting Medigon. Tijdens deze aanstelling verrichtte hij het onderzoek beschreven in dit proefschrift bij Prof. Dr. H. Collewijn op de afdeling Fysiologie I van de Erasmus Universiteit te Rotterdam. Sinds november 1989 is de auteur werkzaam als assistent in opleiding Oogheelkunde in het Oogziekenhuis Rotterdam (opleider: Prof. Dr. P.T.V.M. de Jong).



