



Durham E-Theses

The relation between radio-active collector current potential gradient and wind speed

Groom, K. N.

How to cite:

Groom, K. N. (1963) *The relation between radio-active collector current potential gradient and wind speed*, Durham theses, Durham University. Available at Durham E-Theses Online:
<http://etheses.dur.ac.uk/10287/>

Use policy

The full-text may be used and/or reproduced, and given to third parties in any format or medium, without prior permission or charge, for personal research or study, educational, or not-for-profit purposes provided that:

- a full bibliographic reference is made to the original source
- a [link](#) is made to the metadata record in Durham E-Theses
- the full-text is not changed in any way

The full-text must not be sold in any format or medium without the formal permission of the copyright holders.

Please consult the [full Durham E-Theses policy](#) for further details.

Academic Support Office, Durham University, University Office, Old Elvet, Durham DH1 3HP
e-mail: e-theses.admin@dur.ac.uk Tel: +44 0191 334 6107
<http://etheses.dur.ac.uk>

ABSTRACT

Several workers have suggested that the current flowing to earth through an earthed radio-active collector could, if wind speed was considered, be used to measure the earth's vertical potential gradient. Without measurement of wind speed such a collector has been used to give an approximate estimate of the potential gradient.

The present work sets out to show whether, in fact, an accurate estimate of potential gradient can be got from the simultaneous recording of the current flowing to earth from an earthed radio-active collector and the wind speed. Records were taken at the Durham University Observatory of the two variables mentioned and were compared with records of potential gradient as measured with a field mill.

The records show^{ed} agreement with the results of other workers in that there was: a highly significant correlation between the collector current and the potential gradient; and in almost all cases a significant correlation between collector current and wind speed. However, the results showed that no reliable estimate could be got of potential gradient from the other two records. It was found that the errors in such an estimate were about 6% over short periods (up to three hours) and appreciably greater over longer periods.

It is suggested that the apparently random short term errors are due to rapid fluctuations in wind speed which are not accurately recorded on the anemometer because of the smoothing which was necessary. The long term errors are thought to be due

to variations in the effective activity of the collector because of contamination on the surface of the radio-active laminae restricting the emission of radiation.

**The Relation Between Radio-Active Collector Current
Potential Gradient and Wind Speed**

by

K.N.Groom B.Sc., Grad.Inst.P., F.R.Met.s.

**Submitted in candidature for the degree of M.sc.in the
University of Durham**

The copyright of this thesis rests with the author.
No quotation from it should be published without
his prior written consent and information derived
from it should be acknowledged.



September, 1963.

PREFACE

The units employed in this work are rationalised M.K.S. However, for convenience practical units have been quoted in some diagrams.

Extensive use has been made of diagrams to help in the description of apparatus and expression of results.

The following abbreviations and symbols have been used:

C - curie

ϵ - permittivity of air, taken as 8.85×10^{-12} F/m

and the following prefixes:

M = 10^6 - as in megohm

K = 10^3 - as in kilo-ohm

m = 10^{-3} - as in milliamp

μ = 10^{-6} - as in microamp

n = 10^{-9} - as in nanoamp

p = 10^{-12} - as in picocoulomb

The less conventional n is especially useful in the expression of values of collector current.

ABSTRACT

Several workers have suggested that the current flowing to earth through an earthed radio-active collector could, if wind speed was considered, be used to measure the earth's vertical potential gradient. Without measurement of wind speed such a collector has been used to give an approximate estimate of the potential gradient.

The present work sets out to show whether, in fact, an accurate estimate of potential gradient can be got from the simultaneous recording of the current flowing to earth from an earthed radio-active collector and the wind speed. Records were taken at the Durham University Observatory of the two variables mentioned and were compared with records of potential gradient as measured with a field mill.

The records show^e agreement with the results of other workers in that there was: a highly significant correlation between the collector current and the potential gradient; and in almost all cases a significant correlation between collector current and wind speed. However, the results showed that no reliable estimate could be got of potential gradient from the other two records. It was found that the errors in such an estimate were about 8% over short periods (up to three hours) and appreciably greater over longer periods.

It is suggested that the apparently random short term errors are due to rapid fluctuations in wind speed which are not accurately recorded on the anemometer because of the smoothing which was necessary. The long term errors are thought to be due

to variations in the effective activity of the collector because of contamination on the surface of the radio-active laminae restricting the emission of radiation.

CONTENTS

	<u>page</u>
CHAPTER 1 INTRODUCTION	
Measurement of the earth's vertical potential gradient	1
Simple bound charge method	1
The Field Mill	2
Sign discrimination	2
Problems in the use of the Mill	3
Collectors	4
Water Droppers and Atomisers	5
Collectors which increase ionisation	6
The Radio-active collector as an equaliser	7
The earthed radio-active collector	8
Previous work done with earthed radio-active collectors	
Schaefer's work	8
Bent's work	9
Chapman's work	10
Summary of main points	11
Object of research	12
Note on the effect of wind on radio-active collectors	13
CHAPTER 2 DESCRIPTION OF APPARATUS	
Overall requirements	14
Site of investigation	14
The measurement of radio-active collector current	15
The measurement of potential gradient	16

CONTENTS (Cont'd)

	<u>page</u>
Principles of operation of the Field Mill	16
Electronics of the Field Mill	17
Snags and precautions in construction	17
Contact potential	17
Sources of pick-up	
Piezo-electric or microphonic pick-up	18
Radiated Electric pick-up	18
Magnetic pick-up	19
Faulty earthing	19
Non-linearity of the amplifier diode	19
The amplifier	20
The measurement of wind speed	20
The detection of wind direction	21
The recording apparatus	21
The monitoring apparatus	22
CHAPTER 3 THE CALIBRATION AND PERFORMANCE OF APPARATUS	
The Collector	
Calibration	23
Performance	23
The Field Mill	
Calibration	26
Exposure factor	26
Operation	29

CONTENTS (Cont'd)

	<u>page</u>
The Anemometer	
Calibration and operation	30
The Wind Vane	31
CHAPTER 4 RESULTS	
The taking of results from the records	33
The analysis of data	33
CHAPTER 5 DISCUSSION OF RESULTS AND CONCLUSIONS	
Statistical method employed	37
Confidence intervals	37
Applications	37
Computation of confidence intervals	38
Discussion of results	38
Possible value of fitting other equations	42
Advantage of wind measurement	43
Statement of conclusions	45
Possible reasons for inconsistency of results	46
Short-term fluctuations	46
Effect of surface contamination on day to day variations	47
ACKNOWLEDGEMENTS	49
REFERENCES	50

CHAPTER 1

INTRODUCTION

Measurement of the earth's vertical potential gradient

The vertical potential gradient in the space between the earth and the ionosphere can be measured by two methods.

The first to be used was that of measuring the potential, V , at two heights, a & b , vertically above one another and computing the potential gradient, F , from

$$F = \frac{V_b - V_a}{b - a} \dots\dots\dots (1.1)$$

It is now conventional to take b as the higher of the two points of measurement thus giving the potential gradient a positive value in fine weather. It is often convenient, for measurements close to the earth, to take $a = 0$ where, by definition, $V_a = 0$. Thus equation 1.1 is reduced to

$$F = V_b / b \dots\dots\dots (1.2)$$

The second method of measurement makes use of the charge bound onto the earth's surface by the lines of force ending thereon. The surface charge density, σ , of this bound charge is given by

$$F = \sigma / \epsilon \dots\dots\dots (1.3)$$

It can be seen from equation 1.3 that the charge on any area exposed to potential gradient is directly proportional to that potential gradient.

Simple bound charge method

A simple method of measuring the bound charge has been described by CHALMERS (1955).

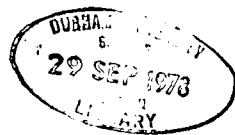

A plate is exposed to the potential gradient and is electrically connected to the grid of an amplifying triode. When the plate is removed from the potential gradient the bound charge will leak away through the grid resistor of the valve giving an amplified impulse in the output circuit. On re-exposing the plate charge will flow back to the plate. The amplitude of the pulses in the anode circuit gives a measure of the potential gradient.

The field mill and agrimeter are two field machines which employ the above principles to give a continuous measurement of potential gradient. Both these machines have been amply described elsewhere but since a field mill has been used in this work it has been thought worth while to describe it again here. A description of the agrimeter can be found in CHALMERS (195⁷~~6~~).

The Field Mill

In the mill two identical vanes are set coaxially such that when the upper earthed vane is rotated it alternately covers and exposes the lower vane. Hence the flowing of the bound charge through the resistance to earth produces an alternating voltage which can be amplified and measured. The amplitude of the voltage is directly proportional to the potential gradient. A more detailed description of the mill will be given in ~~section (2.4)~~ Chapter 2.

Sign discrimination

Because the mill gives an alternating output it is not possible from the output to determine the sign of the potential gradient.

Several methods of sign discrimination have been employed by several workers; all involve further complicating the apparatus.

A method used by MAPLESON & WHITLOCK (1955), among others, involves a secondary pair of smaller vanes driven on the same axle and a phase sensitive amplifier.

COLLIN (1962) has described how the sign of the potential gradient may be determined by applying pulses to the rotating vanes at intervals.

A similar method is to apply an additional field large enough to render the sum of the applied and natural potential gradients positive for all natural negative potential gradients to be encountered.

Problems in the use of the Mill

If there is any contact potential between the two vanes a high zero output will be encountered. Contact potentials are of the order of a few volts but the separation of the vanes is small, about 5mm. Thus for a contact potential of 1 volt there will be a spurious field of 200 volts/metre.

The usual way of overcoming this problem is to use highly polished chromium plated vanes which are unlikely to tarnish. However, it would seem that in an industrial area certainly, the vanes will become coated with foreign matter.

Regular cleaning may appear to be the solution to the problem. This would remove the foreign matter and therefore the contact potential, but one could not be certain that the vanes would be restored to their former state. It would seem then that regular

cleaning would cause the contact potential to vary in an erratic manner.

The alternative is to allow foreign matter to be deposited on the vanes and measure the zero output regularly; using an extrapolation of these results to obtain a correction.

A second problem is that of exposure. If a mill is to be used at any position, other than that of having the vanes at ground level, an exposure factor has to be found. If there is any space charge between the levels of the mills used in determining the exposure factor it will be subject to error. (COLLIN 1963).

ISRAEL (1963) has proposed that all measurements be standardised to height other than ground level, say 2m., and that all apparatus should be installed at this height. If this were done the mill would have to be kept at the potential of the surroundings which would involve more electronics.

Other bound charge methods have been described by CHALMERS (1958)⁷ and IMANIATOV (1962).

Collectors

The potential gradient is measured with collectors by measuring the potential at two heights as described previously. The potential is measured by allowing the always highly insulated collector to reach the potential of its surroundings after which this potential is measured with an electrometer.

Some of the earliest measurements in Atmospheric Electricity were made by Lomonosov and Rikhman with an "electric gnomon" or point. In sufficiently high fields a highly insulated point will

discharge until its potential is equal to that of its surroundings. It would reach the potential of its surroundings even in low fields if it was allowed sufficient time to collect (or give off) the necessary charge by conduction current. For a reasonably rapid response the point collector is only suitable for high fields.

More recently Crozier has used a method employing an extremely highly insulated point with a high degree of electronic feed-back. He refers to his arrangement as a "passive antenna". The details of the set up are awaiting publication, but it is clear that it will need a good deal of electronic amplification.

Water Droppers and Atomisers

The water dropper devised by KELVIN (1859) attains the potential of its surroundings by having the excess charge carried away by the water drops. When there is a potential difference there will also be a potential gradient (in addition to the earth's) so lines of force will end on the dropper and a drop about to leave. If the dropper is negative with respect to the surroundings the lines of force will end on negative charges on the dropper and drop and vice versa. Hence when a drop leaves it will carry away an amount of charge depending upon the potential difference and the capacity of the dropper. As the drops leave the dropper the charge left and potential difference will become smaller and smaller until drops eventually cease to carry any net charge. When this state has been reached the dropper must be at the potential of the surroundings.

For any given collector and potential difference the rate at which the potential is equalised depends upon the rate at which drops are expelled. In order to gain a fast response SMIRNOV (1904) used a water collector in which the water was forced out and atomised under pressure. It is possible, with sufficient water, to use water collectors for continuous recording.

Collectors which increase ionisation

The instantaneous current, i , flowing to a collector is given by

$$i = (V - V_c) / R \dots\dots\dots(1.4)$$

where V is

the potential of the surroundings; V_c is that of the collector and R is the resistance between the air layer of potential V and the collector usually called the "effective resistance". The change of charge of the collector is $dQ = idt$. If the capacity of the collector and its measuring device is C the relative change in potential of the collector in time dt is:

$$dV_c / (V - V_c) = dt / RC \dots\dots\dots(1.5)$$

integrating equation 1.5 gives

(for V, R & C constant)

$$V_c(t) - V = (V_c(0) - V) e^{-t/RC} \dots\dots\dots(1.6)$$

where $V_c(t)$ is the potential of the collector at time t .

It can be seen from equation 1.6 that $V_c(t)$ will approach V exponentially with time. A measure of the effectiveness of a

collector is obtained from the relaxation time $\tau = RC$. τ is the time in which the fraction $(V_0 - V) / (V_0(t) - V)$ becomes equal to e , the base of natural logarithms. Clearly to decrease τ one can decrease R . Now R depends upon the ionisation of the air; so to decrease the relaxation time of a collector one must increase the ionisation in the air close to the collector. The earliest way of increasing ionisation was to use burning or smouldering wicks, candles and fuses.

The Radio-active collector as an equaliser

More recently radio-active substances have been used to enhance the natural ionisation close to the collector. Many workers both experimental WICHMAN (1953), HANNFELD (1932), ISRAEL (1939), MUHLEISEN (1951), and theoretical WAGNER (1955) have investigated the operation of the radio-active collector. They have found that the magnitude of the effective resistance depends upon the radio-active substance used, the current flowing to the collector and upon the ventilation of the collector. The nature of the inter-relation has only been given in a very much simplified case. From a consideration of the ionic currents in the electric field round a spherical collector located in the centre of a spherical conducting shell WAGNER (1955) concluded that the effective resistance depends upon both the potential applied to it and on the wind speed.

DOLEZALEK (1960) in a continuation of Wagner's work has given the equivalent circuit of a radio-active collector. He considers the collector as behaving as an "active, non-linear and asymmetrical four-pole". In his paper he gives characteristics for different loads, (the load being the resistance of the recording apparatus)

and indicates how the values of the components of the equivalent circuit may be determined.

A danger with ionising collectors is that the ionisation may distort the conditions they are attempting to measure. If they are used in conjunction with other apparatus, to measure conductivity for instance, great care must be taken to reject readings taken when wind was blowing from the ionising collector to the other apparatus.

It should be noticed that a wind which blows away ions will cause the effective resistance to increase and so will increase the relaxation time.

KOBAYASHI & KYOZUKA (1962) found that radio-active collectors were not suitable for the measurement of potential gradient during balloon ascents because of the variable influence of wind speed.

The earthed radio-active collector

Another way of using the radio-active collector is to earth it through a galvanometer. If the air close to the collector is at a positive potential, then negative charge will flow up from earth in an attempt to neutralise this potential i.e. in a positive potential gradient a positive current flows from the collector to earth. Similarly a negative potential gradient produces a negative current.

Previous work done with earthed radio-active collectors

Schaefer's work

In an investigation on the Atmospheric Electrical effects of Jet streams SCHAEFER (1955) used a brass needle wrapped with a small strip of gold foil impregnated with a Radium salt, the activity of which was 250 μ C (microcuries). This he mounted on a 36 ft. mast taking the current to earth as an indication of potential gradient.

Schaefer reports that on days with wind speed less than 3 m/sec the effect of even small gusts of wind is considerable. Schaefer suggests that during positive, say, potential gradient the negative space charge left by the positive current forms a sheath masking the potential gradient. On removal of the space charge sheath by a gust of wind there is an increase in current due to the increased potential gradient. Presumably on days with wind speed greater than 3m/sec the wind effectively removes the space charge so that the effect of gusts is not appreciable.

Schaefer regards the earthed radio-active collector as a cheap and efficient instrument with which to measure potential gradient. In his paper Schaefer does not mention any attempt to calibrate the collector but refers throughout to the values of the collector current.

Bent's work

At Mount Washington Observatory BENT (1955) has used a collector of 250 μ C mounted on a 41 ft. tower. Simultaneous records were taken by Bent of the collector-earth current and the meteorological parameters: temperature, wind-speed and dew-point. From his records he computed mean hourly values and so produced a single 24 hour oscillation which indicated the diurnal variations noted by other workers. Bent found also that the current was high on days of high wind-speed and suggests that in his case this may be due to the high winds bringing in atmospheric pollution from downwind.

In summing up he suggests that the earthed radio-active collector is "a simple tool with which to study local pollution and convection".

Bent, like Schaefer, did not make any attempt to get absolute values of potential gradient but merely used the collector current to give an indication of potential gradient.

Chapman's Work

CHAPMAN (1956) has made wind tunnel and free atmosphere measurements with earthed radio-active collectors. His collector was a point round which was wrapped a foil containing $320\mu\text{C}$ of radium.

The collector was placed in a wind tunnel between two plates separated by one metre. His measurements showed that there were three regimes of current; - the first at low plate voltages was one of ion collection, described above; the second was that of saturation when the current increased very little or not at all with increasing field; the third regime occurred at very high fields and was that of simple corona or point discharge.

From his data Chapman has shown that in the ion collection regime a small increase in wind speed can increase the magnitude of the current by a factor of almost ten. He explains that this is due to the space charge which on its removal causes the field at the collector to be restored to the prevailing value of the surroundings.

For very high wind speeds (above 20 m/sec.) in the first two regimes there is a decrease in current instead of the normal increase. This is due to the wind removing ions which would contribute to the current before they are able to reach the collector.

From his out of doors measurements Chapman found that sometimes he had steady records while at other times they fluctuated greatly. He found that the steady records were those taken in the saturation regime or on perfectly calm nights. The records which fluctuated

Type of Collector	Expenditure of water cm ³ /sec	Effective resistance 10 ¹⁰ ohms	Relaxation time (for C = 111 pF) secs	Time to come within 1% of value for C = 111 pF) secs
Water dropper	1.5	13	14.6	67
High speed atomiser	8.3	1.8	2	9
Wick	-	90	100	460
Candle	-	8.1	9.1	42
Radium	-	5.0	3.	9

TABLE 1

were those taken with the current less than saturation in periods of fluctuating wind speed (almost always).

From his data, which he admits, is "rough" he is able to show that the effect of wind is considerable; for example, at 100 V/m the collector current was found to vary between 10 n.amps and 70 n.amps with varying wind speeds.

Summary of main points.

It can be seen from the foregoing sections that there is a wide range of methods of measuring potential gradient. It is desirable to have the simplest instrument possible. This criterion rules out the bound charge methods because of the relatively complicated machines. Of the collectors Table 1, reproduced here from IMANIATOV (1962), may help the choice.

The collectors with the fastest relaxation times are the high speed atomising collector and the radio-active collector. Of these two the radio-active collector is certainly the most convenient as it does not involve ejecting water at high pressures.

MUHLEISEN (1951) has studied experimentally the effect of wind on radio-active collectors. Using polonium collectors of saturation current 20 n.amps he found that in light winds (apparent calm) there were variations in collector output of up to 30% of the mean. He recommends that for potential measurement the collector should be ventilated (to blow away space charge) by a flow of air in the direction of the equipotential surfaces. The presence of this artificial air flow will obscure the natural wind thus leaving the collector current unaffected by natural wind fluctuations. The supply of air flow to the radio-active collector would make it almost

as inconvenient as a water dropper.

The only instrument not yet rejected as being unsuitable for obtaining a measure of potential gradient simply is the earthed radio-active collector.

Object of research

SCHAEFER (1955) and BENT (1955) have used the earthed radio-active collector to give them an indication of potential gradient. However, without a knowledge of the wind speed it is certainly not possible to get anything better than an indication. CHAPMAN (1956) has said "one can draw any significant conclusions about the (radio-active) corona current record as an indication of the earth's electric field only if the wind speed is measured too".

From this report of Chapman's it would seem that it may be possible to get a measure of potential gradient from simultaneous measurements of radio-active collector current and wind speed. The object of the present work is to determine whether or not this is so.

If it is possible to get a reliable measure of potential gradient from apparatus as simple as a radio-active collector and an anemometer it would prove a most useful tool to workers in the field of Atmospheric Electricity.

If it can be done the problem of measuring potential gradient would be very much simplified.

It would be possible to make measurements anywhere without the problem of supplying power to the apparatus either by battery or mains supply. The recording would also be very simple for all that would be needed would be two sensitive galvanometers.

This apparatus would be able to be left for very long periods

without maintenance.

Note on the effect of wind on radio-active collectors

Above it was said that wind would tend to increase the effective resistance of an equalising collector by removing ionisation and so reducing conductivity. Thus for collectors as equalisers, increase in wind speed will reduce the current. In the case of the earthed collector there will always be a very large potential difference between the air close to the collector and the collector itself. Thus the ions will be in a very high field and so virtually unaffected by the wind. (CHALMERS (1962) has discussed this subject in the similar problem of point discharge). Hence the effect of wind is to blow away the excess ions in the space charge sheath which had reduced the field i.e. the effect of an increase in wind speed is an increase of current.

CHAPTER 2

DESCRIPTION OF APPARATUS

Overall requirements

For the investigation it is necessary to measure the vertical potential gradient, the current down the earthed radio-active collector and the wind speed.

Site of investigation

It has been suggested that this investigation could be best performed in a wind tunnel. Here steady conditions can be practically realised, and variables which cannot be controlled (e.g. temperature and humidity) could be kept constant, such that there would be no disturbing influences. The drawback to this proposition is evident when one considers the mechanism of the collector current. Ions are repelled from (as well as attracted to) the collector. These ions affect the field close to the collector. The effect on the field of any ion depends upon its distance from the collector. Even at great distances (theoretically infinite) it has some effect - although small. The integrated effect of many ions may however be appreciable. If the collector were enclosed in a wind tunnel the ions would be prevented from diffusing naturally away from the collector, thus making any free atmosphere interpretation of results obtained virtually meaningless. Furthermore if the wind tunnel walls were conducting there would be distortion of the equipotential surfaces round the collector possibly giving misleading results.

The investigation has been carried out at the Durham University Observatory. The apparatus was mounted on a wooden telegraph pole

and the cables led to the Atmospheric Physics Laboratory of the Observatory where records were taken.

In this work, as with any using natural air flow, it was necessary for the fetch of the wind to be undisturbed. From the pole this is the case if the wind is blowing from anywhere between NW and SW. Fortunately the prevailing wind is westerly in Durham, so there was little inconvenience involved in imposing this restriction on observations.

The measurement of radio-active collector current

The ideal requirements for the collector is that its response should be close to linear for fields less than those giving point discharge. (i.e. saturation is not reached before the onset of point discharge). This will depend on the height of the collector and its geometrical properties. It was thought that a radio-active Lightning Preventor, which was on hand, would be suitable. The Preventor used was a model of the British Lightning Preventor Ltd. (Fig. 2.1)

The radio-active Lightning Preventor, which from henceforth shall be referred to as "the collector", has radio-active material in three laminae distributed symmetrically about the surface of the middle plate. The total activity of the laminae is $460 \mu\text{C}$ giving an intensity of ionisation of 1.5×10^{12} ion pairs / sec. Now if the field is sufficiently large to separate all the ion pairs the maximum or saturation current will be

$$2 \times 1.5 \times 10^{12} \times 1.6 \times 10^{-19} = 0.48 \mu\text{amps.}$$

The radio-active material used is 88 Radium 226 which has a half-life of 1650 years so there need be no worries about any decrease in

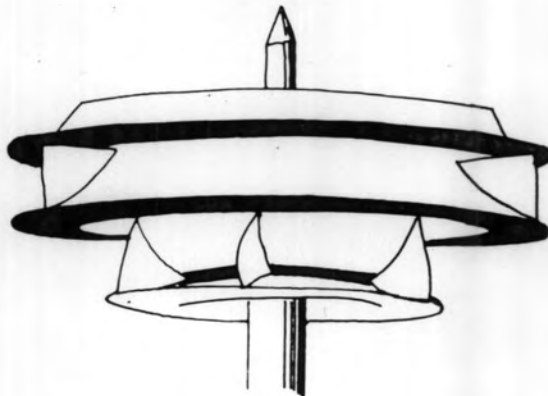
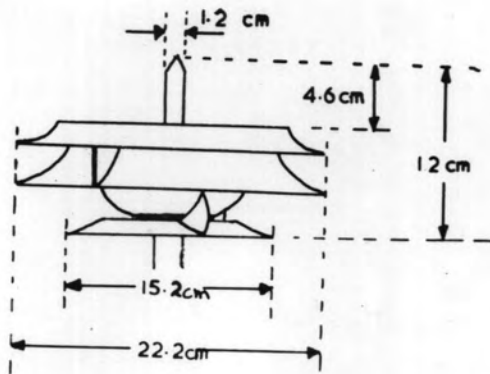

COLLECTOR

Fig 2.1

activity over the time of the investigation.

The collector was mounted on the top of the pole, being 7.3 metres above the ground.

The measurement of potential gradient.

A Field Mill was chosen to measure potential gradient; being an instrument with which the group has had considerable experience. It was mounted 4 metres above the ground on the West side of the post so that during observations the space charge from the collector would not be blown over the Mill where it would affect the potential gradient. The Mill was operated upside down to keep out the rain.

Principles of operation of the Field Mill

The Mill consists of two exactly similar vanes, one of which is the rotor which is made to spin above the stator by an electric motor. The stator is highly insulated by polystyrene blocks and is connected electrically to earth by a 100 M resistor. When the stator is exposed to the potential gradient (as it is four times in each revolution of the rotor) lines of force end on the stator. Hence there will be a bound charge, q , on the stator where

$$q = -\epsilon FA \dots\dots\dots(2.1)$$

where A is the exposed area of the stator. This bound charge can be seen to be directly proportional to the potential gradient. As the rotor covers the stator the lines of force will cease to reach the stator, so the bound charge will flow to earth through the high resistor. As soon as the rotor completely covers the stator it begins to re-expose the stator causing the bound charge to flow back from earth through the high resistor to the stator. The alternating current

through the high resistor has a triangular wave form and a frequency four times that of the rotation of the rotor. The alternating potential difference across the 100 M resistor is amplified, rectified and recorded as a measure of the potential gradient.

Since the output of the Mill is alternating it is not possible to distinguish between positive and negative potential gradients. However, in this work the sign of the potential gradient can be found from the collector current record. The collector current to earth has the same sign as the potential gradient.

Electronics of the Field Mill

In order to maintain the high insulation of the stator a cathode follower is used as the first stage of the Mill amplifier (Fig 2.2). The cathode follower has a very high input impedance (equal to the cathode-grid leakage resistance) and serves to isolate the head unit described above from the amplifying unit. The cathode follower also provided the energy necessary to convey the signal from the head unit along the cables to the recording apparatus.

Snags and precautions in construction

The snags encountered in the construction are :-

- (i) contact potential on vanes (see Chapter 1)
- (ii) pick-up from various sources. This is serious because the output is AC, any pick-up is therefore registered as signal
- (iii) non linearity of the amplifier diode.

Contact potential

The vanes are made of stainless steel. They are polished so that they have as near identical surfaces as possible, thus minimising the effects of contact potential.

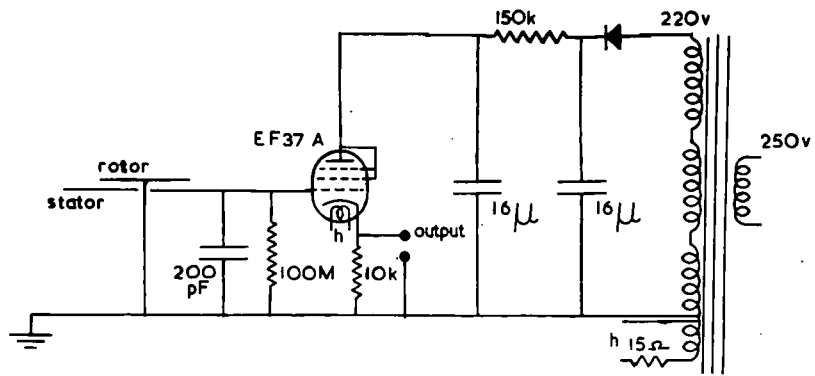

HEAD UNIT & CATHODE FOLLOWER

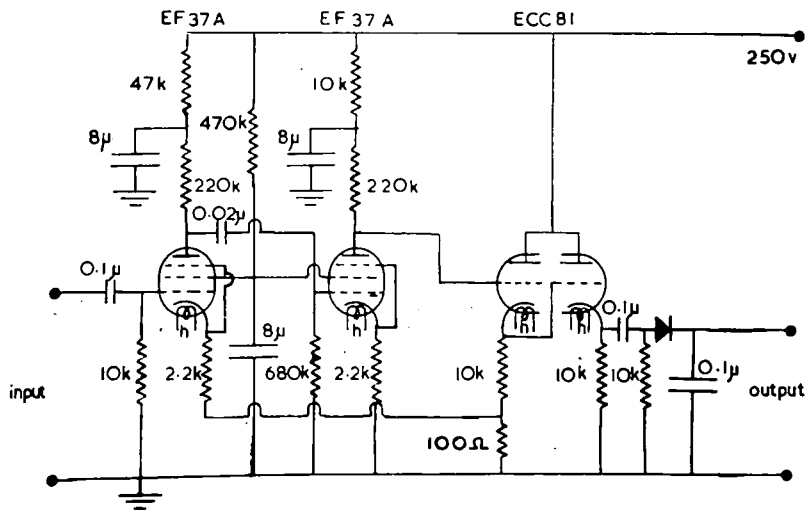

MILL AMPLIFIER

Fig 2.2

Sources of pick-up

Piezo-electric or microphonic pick-up

Vibration of any cable or valve can produce interference due to the piezo-electric effect. The valve in the cathode follower is very susceptible because of its having to be in the head unit with the motor. Valves have been designed especially to minimise microphonic pick-up, e.g. EF 37A and EF 86. Such a valve was used with the extra precaution of mounting it on a frame suspended by rubber bands. The components associated with the cathode follower were also mounted on this anti-vibration mounting.

After the cathode follower there appeared to be no appreciable microphonic pick-up so that it was not necessary to support the signal cable rigidly between the cathode follower and the amplifier.

Radiated electric pick-up

Any component or wire carrying alternating currents will radiate. This radiation will be received by any output wires unless precautions are taken. Each section of the head unit is screened from every other by a sheet of earthed aluminium. The outer case of the head unit is also screened against radiation from external sources. Further precautions are to use screened mains cables throughout and to screen the input (grid) and output (Cathode) leads of the cathode follower. The only part of the field mill which cannot be effectively screened is the stator which, being large, can pick-up a considerable spurious signal. This can be minimised by employing an earthed guard ring at the level of the vanes.

If the heaters of the cathode follower tube are AC the radiation is effectively eliminated by the use of a "humdinger".

This is a low value potentiometer (up to 50 ohms) put in parallel with the heater windings of the transformer with the centre tap earthed. This system acts as an L - R filter, the centre tap is adjusted until the 50 c/s pick-up as observed on an oscilloscope is a minimum. The humdinger was found to be as effective as using DC heaters.

The motor used was a 240 volt, 50 c/s mains synchronous motor. The synchronous motor was used after an attempt had been made with a commutator motor. The signal from the sparking of the commutator could not be reduced to a sufficiently low level so as to be insignificant in fine weather fields. (There is of course no commutator in a synchronous motor).

Magnetic pick-up

The only source is the transformer; the trouble could be removed by enclosing the transformer in a mu-metal box. However, the easier course of moving the transformer a few feet from the mill was adopted with complete success.

Faulty earthing

Pick-up due to faulty earthing of the rotor will appear on the displayed signal as "grass". Some workers have found that it is necessary to use a mercury cup to earth the rotor (e.g. ECCLES 1961). Trouble was not however encountered with the more conventional carbon brush earthing.

Non-linearity of the amplifier diode

The AC output of the mill has to be rectified before being recorded. Crystal diodes of the usual type are not linear for small outputs. In order that most fields would be recorded on the linear part of the characteristic an amplifier was employed.

The amplifier

The amplifier employed was a hybrid of the design successfully used by MILNER (1960) and RAISBECK (1963) the circuit diagram is shown in Fig. 2.2.

The power for the amplifier was obtained from a conventional power pack with HT stabilisers.

The Measurement of wind speed

Since the site chosen was the Durham University Observatory it was at first thought that the Dines Pressure Tube anemometer on the top of the building might be used to measure wind speed. There are however, several disadvantages to this proposition. The chart speed of the Dines is only one inch per hour. This could not be interfered ^{with} as it would disturb the meteorological recordings of the Geography Department. The Dines has, for the convenience of the Geography Department been biased so that the sensitivity below 5 meters per second is greatly suppressed. Short-term wind changes occur very locally so that the wind speed at the Dines position may be (and very often is, as later comparisons have shown) very different from the wind at the position of the collector.

Any one of these points is sufficient justification for the adopted procedure of using an anemometer at the same height as the collector on the pole. The anemometer is mounted to the side of an east-west line drawn through the collector so that the rotating cups do not interfere with any space charge close to the collector when the wind is westerly.

The type of anemometer employed is a three cup generator. Its operation depends simply upon the principles of electro-magnetic

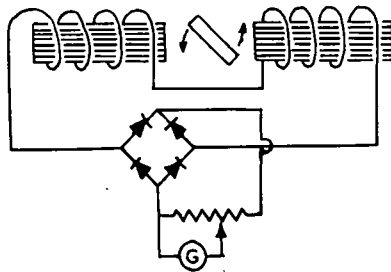
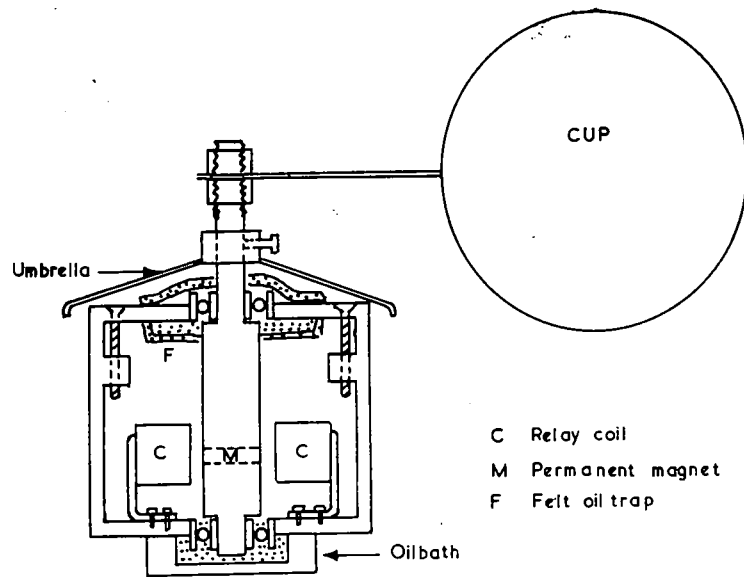

ANEMOMETER

Fig 2.3

induction. The wind causes the cups to rotate with a permanent magnet. The magnet rotates between the ends of two 1000 ohm relay coils (Fig. 2.3). The size of the alternating emf. induced in the coils is directly proportional to the angular velocity of the magnet. The output is rectified and recorded with a moving coil galvanometer. The long period of the galvanometer (30 sec.) causes the peaks of the full wave rectification to be smoothed and also causes the record to give the average value of the wind of the past half minute. (This is also the case with the other two records).

The detection of wind direction

In order that no records would have been taken when the wind was not from the west a wind vane was constructed. Instead of recording the direction from which the wind was blowing the vane was arranged to actuate a switch which passed current only when the wind was between NW and SW. This switch closed a circuit allowing lights to shine, one at the monitoring pannel and the other onto the photographic recording paper, whenever the wind was in the quarter suitable for recording.

The moving vane carried a carbon brush on an arm which made contact in the 90° arc when the vane pointed between NW and SW.

The vane was mounted on a post close to the telegraph pole. It was not mounted on the telegraph pole in case its swinging disturbed any space charge present.

The recording apparatus

The three variables were photographically recorded by directing the reflected beam from the mirror galvanometers onto a rotating drum camera. The galvanometers were used at critical damping, this

condition being maintained throughout range changes by the use of Ayrton Shunts.

The monitoring apparatus

Little monitoring was found to be necessary in this work. The wind speed was recorded on only two ranges, either one of which was usually suitable for long periods. The potential gradient record was monitored with a moving coil microammeter. The collector current was found to follow the field, for monitoring purposes, quite closely. If it had been necessary to monitor the collector current independently a high gain D.C. amplifier would have been needed.

The wave trace from the mill was monitored on an oscilloscope so that any pick-up could be detected when it arose. (None was in fact detected). Such monitoring by oscilloscope, although helpful, is not really necessary but since an oscilloscope was available it was put to this use.

CHAPTER 3

THE CALIBRATION AND OPERATION OF APPARATUS

The Collector

Calibration

It was necessary to measure the current flowing to earth from the collector. This, as has been said, was done with a sensitive galvanometer. The galvanometer had a sensitivity for 1 metre separation of scale and galvanometer of 0.91×10^{-9} amp/cm. Fig. (3.1) shows the calibration curves for the collector current against deflection on the photographic paper for the ranges used.

The ranges were chosen so that a fairly high resolution could be made in all conditions of field of interest. Table 3.1 shows the factors of interest regarding the collector ranges.

It can be seen from the table that the ranges will not allow study of currents much greater than 1 microamp. This is not however, of any consequence because this is in the region of point discharge and is above the region of the collectors saturation.

Operation

On closing the collector circuit there is a very large surge current three or four times the value it falls to after the surge. When the collector circuit is not closed the collector is not earthed. It is therefore acting as an equaliser so will be at the potential of its surroundings; on being earthed the collector will discharge an amount of charge depending upon the potential of its surroundings and its capacitance. This surge current may lead to confusion when the collector is switched on because the long period of the galvanometer

Range	Sensitivity n.amp/cm	Full Scale defl'n n.amp	Resolution + or - n.amp	Standard value of β error %	Condition of potential gradient for which suitable
A	9.1	60	1	3	low fine weather
B	18.2	125	3	5	undisturbed
C	91	600	10	3	disturbed, less than paint discharge onset
D	182	1,250	30	5	stormy, collector saturation

β The standard value was taken as that at $\frac{1}{2}$ full scale. Thus avoiding confusion about infinite proportional errors at zero deflection.

Table 3.1

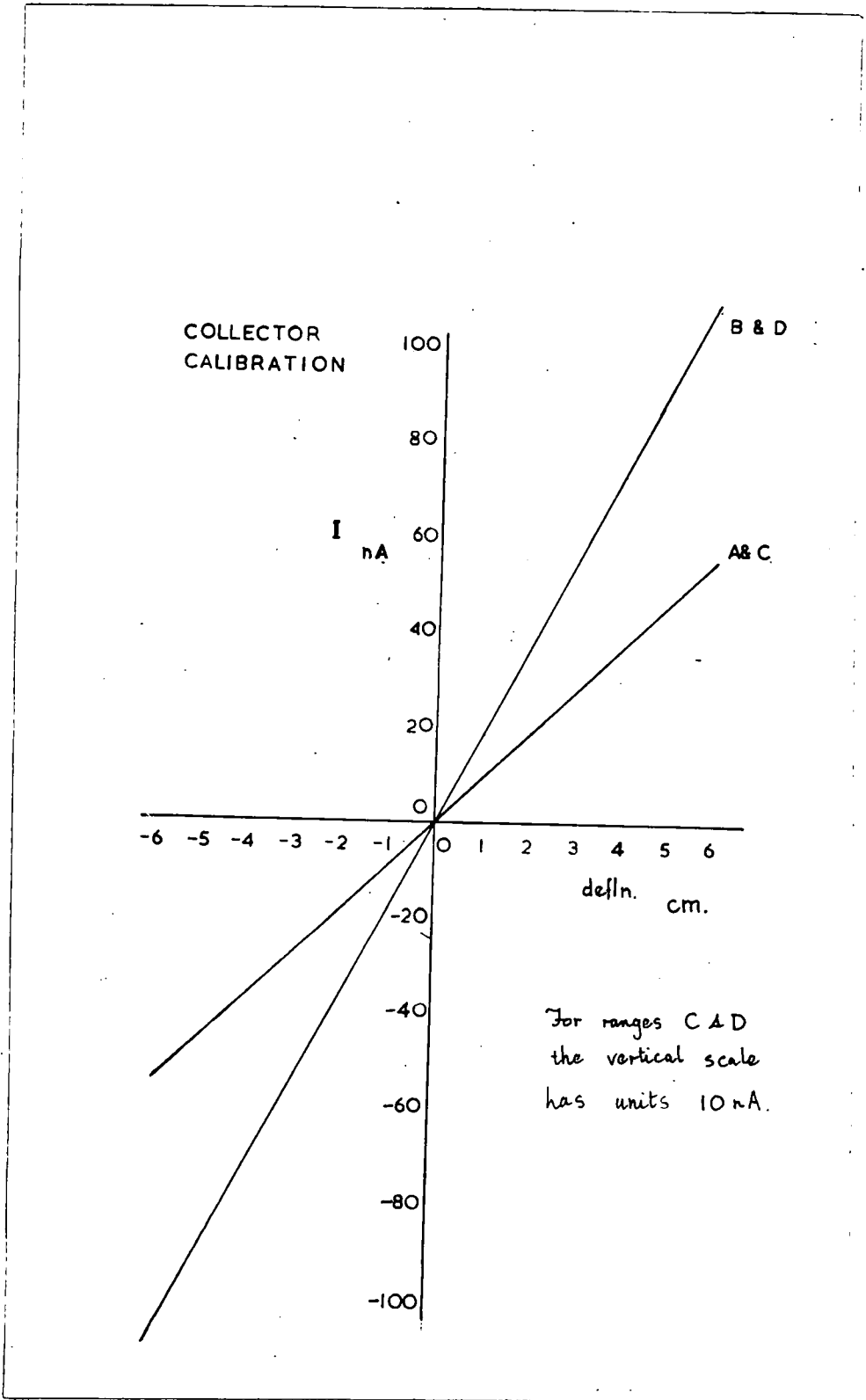

Fig 3.1

causes it to be in evidence for half a minute after switching on (The time when the ranges are selected).

The problem was very easily overcome by simply not opening the collector circuit but merely shorting the galvanometer to get a zero trace on the record. This of course keeps the collector permanently earthed.

It was noticed very early in the investigation that the collector gave spurious results during and immediately following precipitation. During these conditions the collector current was well off scale on the least sensitive range i.e. the current was much greater than a microamp, always positive and independent of the potential gradient.

It had been expected that strange results may be encountered during rain due to there being perhaps a film of moisture over the laminae reducing the emitted ionisation. This would clearly reduce the current not increase it.

It was thought possible that in rain the collector may act in some way as a water dropper: the drops carry away negative charge in positive potential gradient. If the dropper was earthed, as it is in this case, a negative current would flow up from earth, to replace this charge i.e. a positive current would flow to earth through the galvanometer from the collector. In a negative potential gradient the galvanometer would register a negative current from the collector to earth due to the dropper effect.

The current observed was always positive, even in negative potential gradients, so could not therefore be accounted for by the dropper effect. In addition the dropper effect would produce a current dependent upon the magnitude of the potential gradient.

The current due to the charge on rain drops would be far too small to have any appreciable or even detectable effect on the collector current.

The most probable cause of the effect is water bridging the rubber insulation which holds the collector to the pole. On either side of the 0.1 inch of rubber there is a metal fitting. A laboratory experiment showed that the voltage between the pieces of an exactly similar arrangement soaked in water was 20 mV.

There is then during rain a closed circuit to earth through the galvanometer and from earth up the pole the emf. being a voltaic cell of the metal pieces bounding the insulation. Assuming the pole to have a resistance during rain less than its dry value of $75k\Omega$ the total resistance of the loop is the same order as that of the galvanometer, $3k\Omega$. The current flowing in the loop will be of the order of 10^{-4} amps.

This would account for the value observed.

Evidence in support of this theory is that during the winter of 1962-63 the collector showed this current for many days on end while there was no precipitation but a thick layer of snow bounding the collector insulation.

The collector could only be used with its insulation as it is when dry conditions were present. This was not regarded as too serious a drawback as if the insulation had been made 'safe' the other effects described would have come into play. So that in any event the dry and wet behaviour of the collector would be so different as to be incompatible.

The Field Mill

Calibration

The field mill is calibrated very simply by putting it into an artificial field between two plates and applying a potential difference to the plates. Care had to be taken to keep separate calibration curves for positive and negative potential gradients on the lowest range because of the systematic error due to contact potential. The calibration curves are shown in Fig. 3.2.

Exposure factor

Since the mill was not operated upright with the vanes at ground level the potential gradient measured would not be that at ground level. Two attempts to determine the exposure factor were made.

The exposure e is given by

$$F = e F' \dots\dots\dots (3.1)$$

where F is the potential gradient at the ground and F' is the potential gradient measured by the field mill. F' is a measure of the number of lines of force ending on the stator of the mill.

The exposure factor has been defined to be the factor by which the field has been concentrated. This definition gives the reciprocal of that in equation 3.1. The attempts to determine e were made by running two mills simultaneously. One in its position on the post and the other in the observatory calibration pit with its vanes at ground level. The mill in the calibration pit was constructed for work on precipitation electricity reported elsewhere by Collin, Raisbeck and Chalmers (1963) by Mr. H.L. Collin to whom the author is indebted. It was calibrated by the author in the manner described above. From a comparison of the records of the two mills the

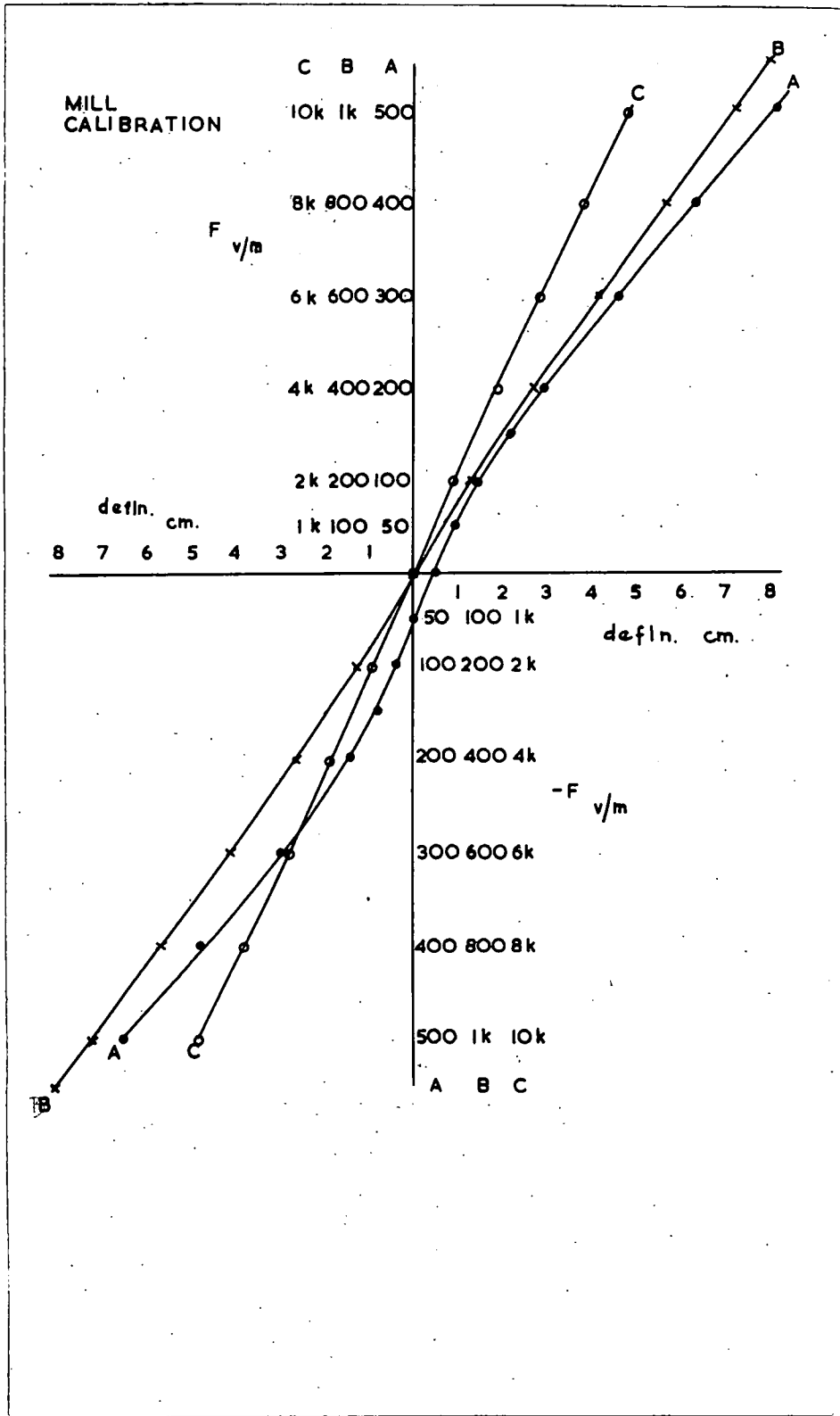

Fig 3-2

exposure factor can be easily found.

For the two attempts, two fine still days with clear sky were chosen as being the most suitable for the non-existence of space charge in the layer between the levels of the mills. Space charge would cause the potential gradient to be different at the two heights so the value of e found would be false.

The first attempt produced a record for 75 minutes and gave, taking readings at $\frac{1}{2}$ minute intervals, a mean for e of 0.265 with a variance of 0.034. The second determination about a fortnight later gave for a 66 minute record a mean value for e of 0.319 with a variance of 0.058.

Statistical tests show that the apparent differences are in fact significant differences. There is a variance ratio of

$$F_{149, 132} = \frac{\text{variance 1}}{\text{variance 2}} = 1.713$$

which is

significant at 0.5%. Here the conventional statistical notation is being used i.e. The probability of getting a value of F with degrees of freedom 149 and 132 as large as 1.713 by chance from samples having the same variance is less than 1 in 200.

A 'student's t ' test on the difference of the means shows the difference to be overwhelmingly significant. The value of t is 9.687. Since t is a normalised function the probability of this value of t by chance from populations of the same mean is equal to that of getting a value of 9.687 standard deviations from the mean of a normal population a probability of very much less than 1 in 10^{10} .

These figures show that there can be no doubt that the determination of exposure factor was erroneous on at least one of the occasions.

A similar account to the following has been given by Collin (1963) but is worth repeating here with emphasis on error in exposure factor rather than potential gradient.

The notation used is as follows:-

Potential gradient at ground = $f \ v/m$

Potential gradient at height $h = F \ v/m$

Potential gradient component at ground due to the space charge between the ground and the height $h = s \ v/m$

So $F = f - s$

Potential gradient as measured by the field mill at height

$h = M \ v/m$

The true exposure factor e

The measured exposure factor e'

from the experiment the exposure factor will be given as;-

$e' = f/M \dots\dots\dots (3.2)$

This assumes that there is no space charge.

Now $M = F/e \dots\dots\dots (3.3)$

So $e' = \frac{f}{F} e \dots\dots\dots (3.4)$

therefore $\frac{e'}{e} = \frac{f}{F} = \frac{f}{f - s} = \frac{1}{1 - s/f} \dots\dots\dots (3.5)$

The error in the determination made is about 20%

i.e. $\frac{e'}{e} = \frac{1}{1 - s/f} = 1.2$

hence $s = \frac{1.2 - 1}{1.2} f$

On days suitable for exposure factor determination f is of the order of 100 v/m. So to give 20% error

$$s = 20/1.2 = 16.6 \text{ v/m}$$

Now for uniformly distributed space charge density, ρ , $s = \frac{\rho h}{\epsilon}$

$$\rho = \frac{s\epsilon}{h} \dots\dots\dots (3.6)$$

Thus the space charge density necessary to give an error of 20% in exposure factor is

$$\begin{aligned} &= \frac{16.6 \times 8.85 \times 10^{-12}}{4} \text{ coulombs / m}^3 \\ &= 36.9 \text{ pC/m}^3 \end{aligned}$$

So if there exists about 35 pC/m³ one can expect a very large error in e . Since this is of the same order of magnitude as the typical average values which have been found (although higher) it would seem to be sufficient reason for disregarding any experimental determination of exposure factor using the method described.

An alternative determination could be made for simple cases by geometry but in this investigation the proximity of large bushes renders this approach impracticable.

The potential gradients referred to throughout, except where otherwise stated, refer to the potential gradient at the vanes of the mill. It should be noted that this potential gradient is related by a constant of the order of 0.3 to the normally quoted potential gradient at the earth's surface. This constant, however, cannot be reliably determined.

Operation

It was mentioned in the introduction that with field mills

there is a danger of a drift in calibration due to changing contact potentials between the vanes. In view of this calibration was repeated at the end of the investigation. On the higher ranges, B and C, there was no difference that could matter. On the lowest range A there was a difference, the zero output had changed slightly and the calibration had a systematic difference from the initial calibration. However a closer examination of the calibration data showed that the second calibration lay within the errors of the first (and vice-versa). In view of this, the first calibration was used throughout.

Except for the trivial maintenance of replacing the rubber bands which perished while supporting the cathode follower unit the mill worked perfectly throughout the investigation.

There was also no trouble with the amplifier and its power-pack

The Anemometer

Calibration and operation

The anemometer was calibrated in the wind tunnel at the National Coal Board, Scientific Division, Benton, Newcastle upon Tyne. The emf. generated by the anemometer was recorded on a portable 'Scalamp' galvanometer. To obtain the calibration curves shown in Fig 3.4 the recording galvanometer was calibrated against the Scalamp for the two ranges used.

The upper curve was extrapolated when the wind was very high in order that winds in the higher levels did not have to be rejected.

At a first calibration it was noticed that there was a systematic error involved. The anemometer was more sensitive when wind speeds were reached by decreasing the wind from a higher

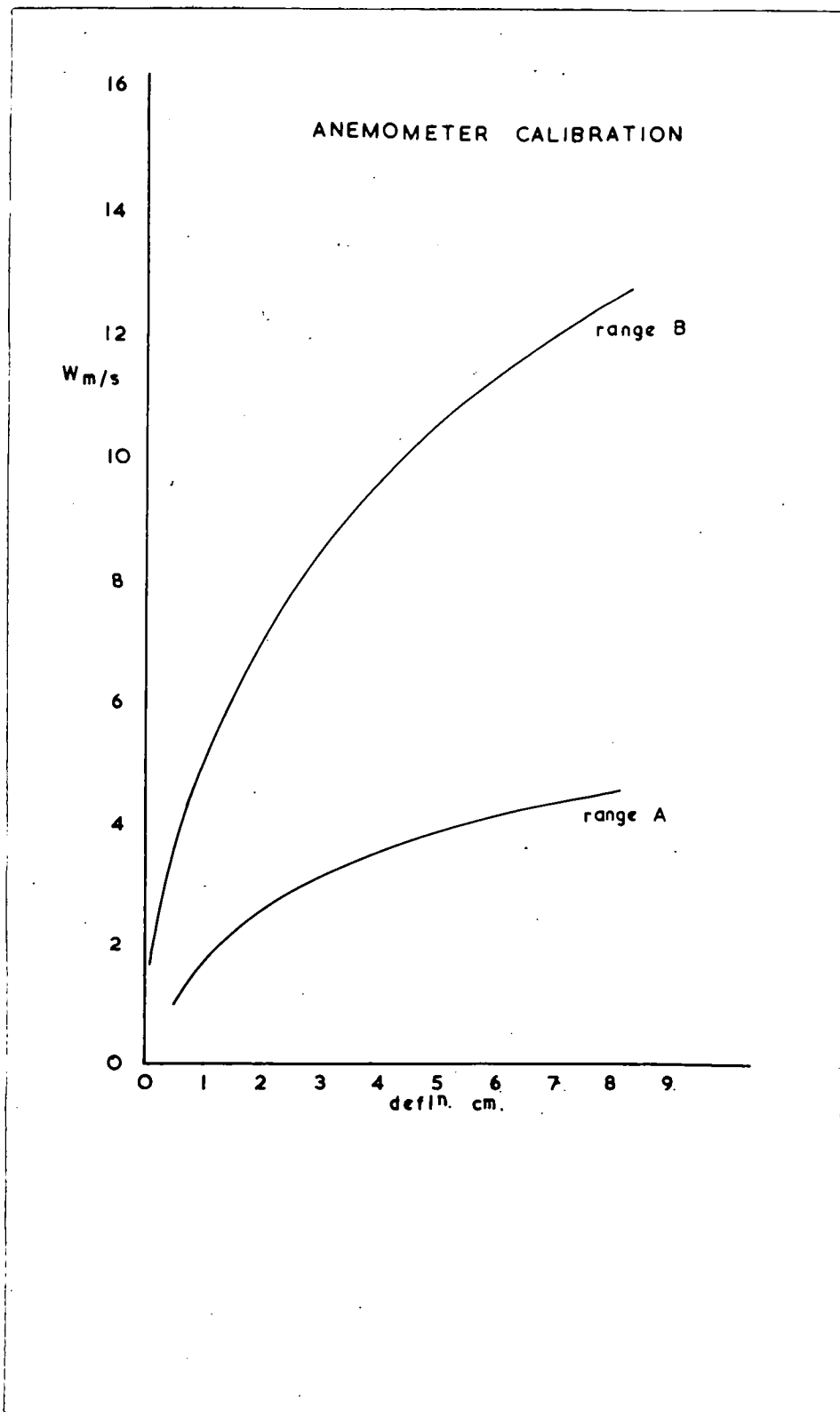

Fig 3.4

value that it was for the same wind speed having been reached from a lower value. This was subsequently found to be a lubrication fault. It was found that the error could be eliminated if the bearings were kept in a bath of light oil or a felt oil trap Fig. 2.3.

The Benton calibration showed that the anemometer had an onset value of wind speed for rotation of just below one metre per second thus, values of wind speed below this value (1 m/sec), which were in fact recorded, were subject to large errors.

The only maintenance which was found to be necessary was occasional oiling of the bearings.

A repetition of the calibration at the end of the investigation showed that the anemometer was still functioning satisfactorily.

Wind Vane

No calibration of this instrument was necessary - it only had to be set up such that the switch closed between NW and SW.

Soon after the investigation was begun the vanes developed an electrical fault. Since it could easily be seen from the laboratory it was not repaired but used simply as a visual indicator.

CHAPTER 4

RESULTS

Records were taken from the beginning of January 1963 until the end of May 1963. At the beginning of March the camera was changed as mentioned in Chapter 2. Before this time records were each of 30 minutes duration. None of these short records were analysed in detail. Some however, were analysed graphically (see Fig. 5.8 example) to help decide on the method of analysis finally adopted.

During this period of two months when the half hour records were taken, all weather conditions and wind directions investigated. A brief glance at records taken in rain or when snow was on the ground showed the anomalous behaviour described in Chapter 3.

After the new camera was installed longer records could be taken. These were taken almost entirely in fine or at least dry weather. Only occasionally were records taken in the wind blowing from direction other than WEST.

Of the ten records finally analysed eight were with Westerly winds comprising a total observation time of 12 hrs. 40 mins, one of ~~the~~ 70 mins. was with a Southerly wind and one of 105 mins. was with a Northerly wind. The object of taking the records with wind direction other than West was to see if there was in fact any difference as suspected. (Chapter 2)

A typical record is shown in Fig. 4.1. This shows an obvious correlation between the collector current, the upper trace, and the potential gradient, and the middle trace. Another record

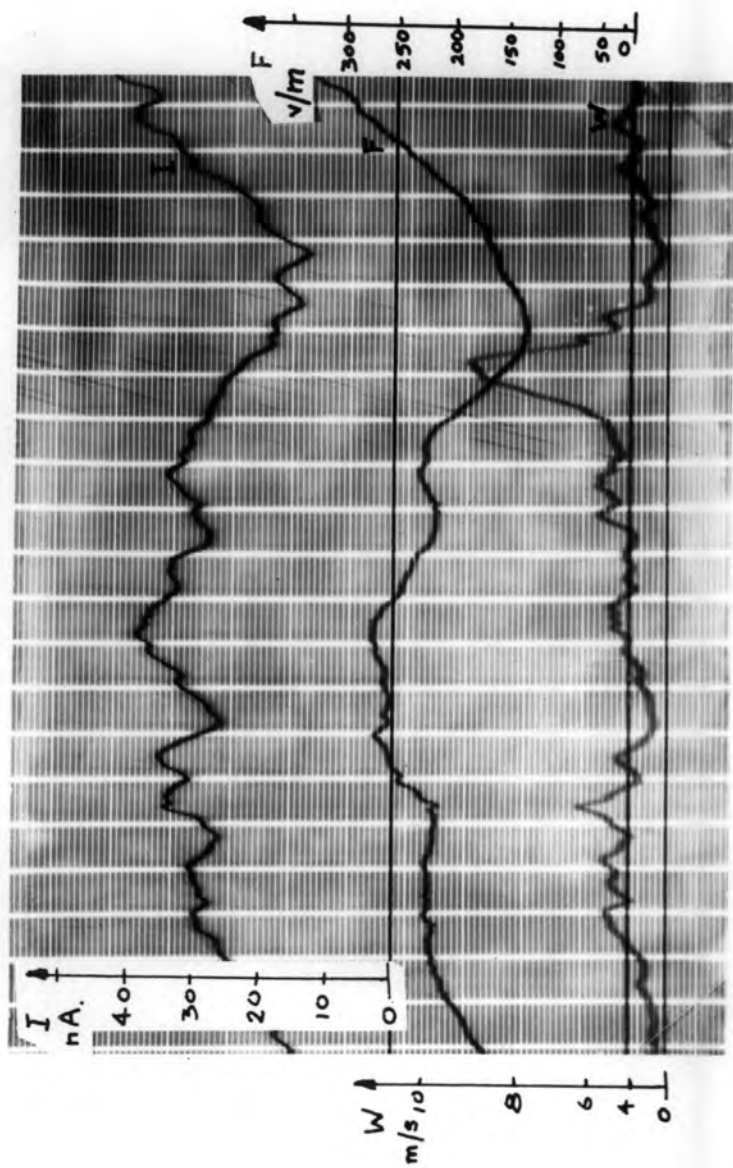

Fig 4.1

fig. 4.2 shows a good correlation between the collector current and the potential gradient. Superimposed on the collector current record are peaks corresponding to the peaks in the wind speed i.e. gusts. This shows how the current increases when the wind blows away the space charge sheath.

The third record shown Fig. 4.3 shows an effect of interest. There is a very large gust of wind which does not cause an increase in the collector current. This is because here the potential gradient is so low that the current is only 1 n.amp hence the negative sheath left screening the collector is virtually non-existent, so that its being blown away is of no consequence.

THE TAKING OF RESULTS FROM THE RECORDS

It can be seen from the records shown that there are vertical lines drawn at regular spacing due to the switching off of a fogging lamp. These lines are drawn each half minute. Now at each of these half minute lines, measurements were made with scales constructed with reference to the calibration curves and entered on data sheets. The information from the data sheets was punched into five hole paper tape suitable for entry into the University "Pegasus" Computer at Newcastle.

Having got the data in a form that could be handled by the computer empirical lines of best fit could very quickly be obtained.

THE ANALYSIS OF DATA

Graphical analysis had shown that there seemed to be differences in behaviour of the collector from day to day. In view of this the data were kept separate and not mixed so that the day-to-day differences could be observed in detail and if possible

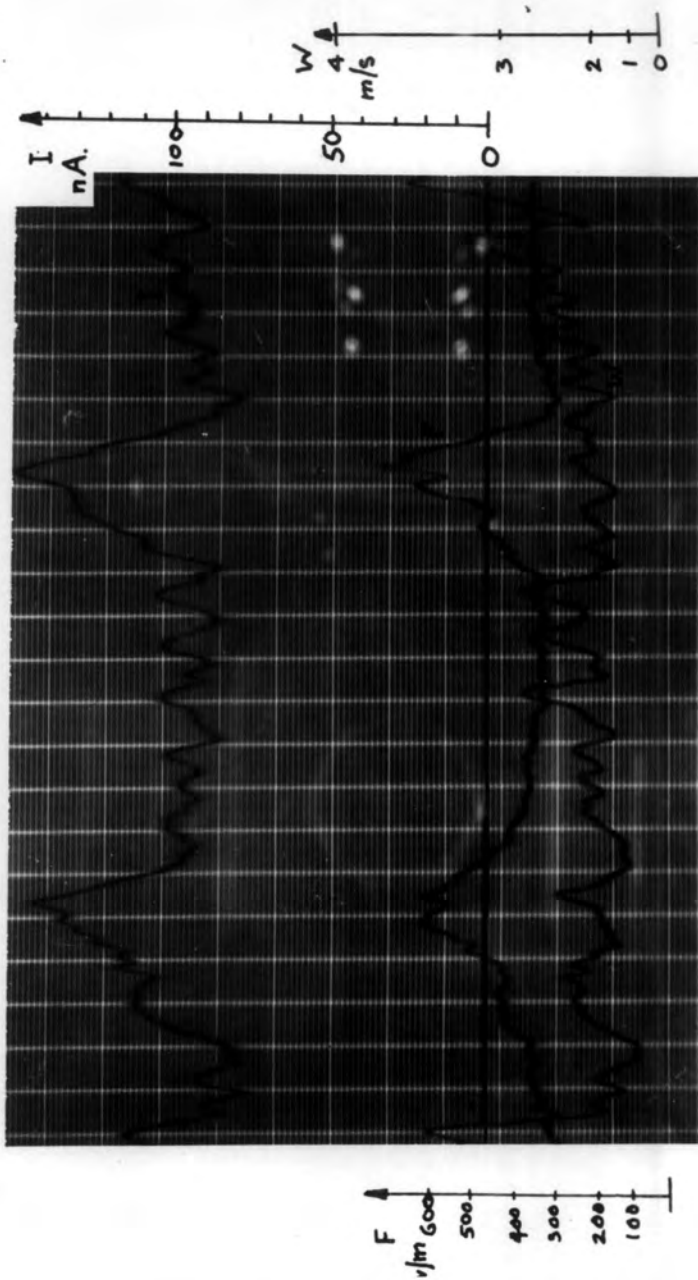

Fig 4.2

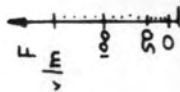
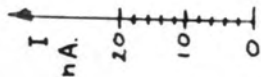
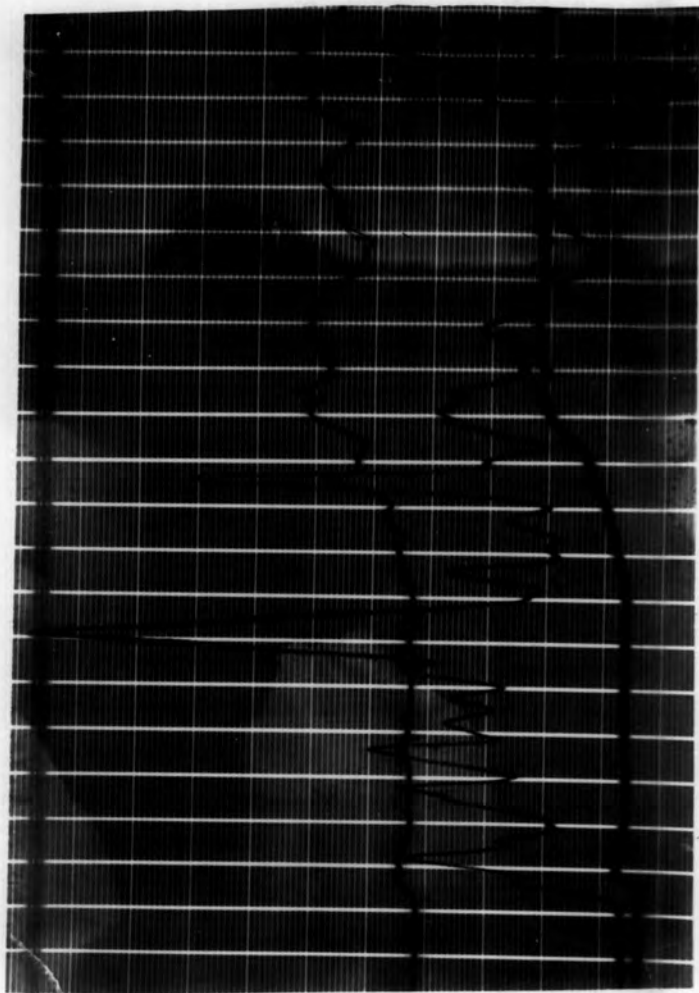
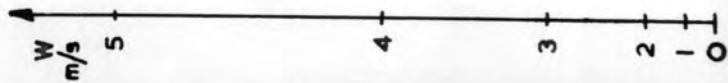

Fig 4.3

explained.

The computer performs the operation of multiple regression in the conventional statistical manner of minimising the squares of the deviations of points from the regression equation. If desired the significance of the regression equation can be tested up to the 0.1% level i.e. any coefficient which is not significantly different from zero will be set equal to zero and a corrected equation for the remaining variables calculated. The statistical principles employed can be found in any fairly advanced statistical text book.

Two regression equations were found for the ten records selected for analysis and these were:-

$$I = a + bF + cW + dWF \dots\dots(1)$$

and $I + k F^p W^q \dots\dots\dots(11)$

The radio-active collector in some ways resembles the discharging point collector. There has been a good deal of work done on the mechanism of point discharge e.g. CHALMERS (1952, 1952a, 1957a, 1962).

From theoretical considerations CHALMERS (1962) has derived an approximate expression for point discharge current:-

$$i = kW (F - F_0)$$

It was suspected that an equation of this form may fit the results obtained with the radio-active collector. With a radio-active collector the onset field should be zero so that we should have:-

$$i = kWF$$

To test this equation (11) was fitted with the expectation that both p and q would be unity.

Equation (1) was fitted to see whether there were any onset

values. If all the coefficients in equation (1) were non zero the equation could be rearranged into a form such as:-

$$i = k(W - mW_0) (F - nF_0).$$

Equation (1) cannot be fitted by straightforward multiple regression unless WF is treated as a third independent variable. This can be done without any loss of generality, by expanding the data to produce the product WF.

Equation (11) cannot be fitted by multiple regression of I against any variables, however, a straightforward multiple regression can be performed to fit the equation:-

$$\log I = k + p \log F + q \log W \dots\dots\dots (11a)$$

from which a simple transformation to equation (11) can be made. To save laborious calculations the computer was used to expand the data to give WF and the natural logarithms.

A further two equations were fitted to the six longer records:-

$$F = a + bI + cW \dots\dots\dots (111)$$

$$F = a' + b' I \dots\dots\dots (1v)$$

N.B. a,b,c, are not the same as those in equation (1)

In fitting planar and linear equations one must expect to run into trouble when the collector saturates. To avoid this trouble only those values of the collector current on the linear current - field curve should be used. Erroneous values for the coefficients would be got from readings on the curved portion of same. Clearly it is not possible to determine where the linearity ends until the curve has been drawn. The curve is a statistical fit so there will be difficulty in finding a criterion for rejection on the grounds

of non-linearity.

A criterion can, however, be found from the data of CHAPMAN (1955). The characteristics he draws are linear until the collector current reaches 0.56 of the saturation current. In this case the saturation current is 480 n.amps, so that the only useable data for planar and linear equations must have collector current

$$0.56 \times 480 = 270 \text{ n.amps.}$$

Table 1 shows that in no case did the collector current exceed this value thus making no rejection necessary. The reason that no values of collector current near saturation were observed is because it was not possible to take records in wet conditions when most high fields occur. The author was not fortunate enough to observe any occasions when a storm cloud was approaching yielding high fields before the onset of precipitation. Nor was any other "dry" high field observed.

The results are summarised in Tables 1, 2, 3, 4.

Table 1 gives a summary of the data and the recording conditions.

Table 2 gives the coefficients in equation (i)

Where the coefficient is zero it has made no significant improvement to the fit at the 0.1% level of significance.

Table 3 gives the coefficient and indices in equation (ii) the value of k has been taken from equation (iia) as $\exp(k')$.

Table 4 gives the coefficients of equations (iii) and (iv).

No.	Date 1963	No. of sets	Wind dir'n.	R.R. %	Potential gradient V/m			Collector Current NA			Wind Speed m/s			Correlation Coeffts. $\times 10^{-5}$		
					Min.	Mean	Max.	Min.	Mean	Max.	Min.	Mean	Max.	F - I	H - I	F - H
1	13/3	140	S	83	350	632	1,000	7	86	135	0.4	2.5	3.9	<u>839</u>	<u>501</u>	<u>128</u>
2	25/3	191	W	86	210	464	695	31	72	120	5.9	9.5	12.6	<u>815</u>	<u>138</u>	- 81
3	28/3	120	W	86	230	383	650	24	60	105	2.3	4.3	8.4	<u>839</u>	<u>658</u>	<u>283</u>
4	2/4	62	W	77	115	257	465	15	33	68	2.8	4.2	4.9	<u>951</u>	- 6	-204
5	29/4	204	W	87	100	193	290	14	28	40	3.2	6.2	10.2	<u>699</u>	<u>435</u>	-154
6	29/4	276	W	87	180	284	490	23	42	79	4.8	9.3	12.6	<u>802</u>	<u>201</u>	<u>171</u>
7	30/4	304	W	89	140	249	500	12	29	57	1.4	4.7	9.2	<u>828</u>	<u>248</u>	-195
8	30/4	194	W	89	180	340	645	24	50	103	4.1	6.9	11.4	<u>869</u>	<u>304</u>	- 84
9	1/5	171	W	83	190	297	460	21	47	60	2.5	6.7	12.3	<u>714</u>	<u>281</u>	-154
10	27/5	210	N	72	10	172	345	1	18	48	0.6	2.5	4.7	<u>848</u>	<u>685</u>	<u>336</u>

In the correlation coefficients the double underlining signifies that the coefficient of correlation is significant at the 0.5% level.

The single underline indicates significance at 2.5%.

No.	a	b	c	d
1	- 37.63	0.1379	7.315	0
2	- 4.564	0.1267	0.8946	0
3	- 30.37	0.1470	3.809	0
4	- 6.546	0.06996	0	0.009758
5	+ 2.489	0.06429	0	0.005394
6	- 2.741	0.09507	0	0.003320
7	- 2.561	0.08013	0	0.004744
8	+ 0.5222	0.06675	0	0.005834
9	+ 12.45	0.07618	0	0.002897
10	+ 2.526	0	0	0.01699

Coefficients of $I = a + bF + cW + dWF$

TABLE 2

No.	k	P	q
1	0.0293	1.131	0.4103
2	0.164	0.8688	0.2568
3	0.0407	1.010	0.5762
4	0.0169	1.132	0.5990
5	0.067	0.9121	0.4953
6	0.0225	1.117	0.4084
7	0.0241	1.110	0.4166
8	0.0312	1.017	0.5513
9	0.318	0.7569	0.2636
10	0.0222	1.113	0.5720

Coefficients and indices of equation

$$I = kP^q$$

TABLE 3

No.	a	b	c	a'	b'
2	177.0	5.530	- 5.621	81.12	5.534
5	111.2	5.755	- 6.276	72.98	4.285
6	176.5	4.920	- 5.226	96.46	4.465
7	130.2	7.094	- 8.715	69.92	6.289
8	202.5	6.207	-12.20	67.29	5.472
10	110.0	8.488	-16.77	65.27	5.968

Coefficients of equations

$$F = a + bI + cW \text{ and } F = a' + b'I$$

TABLE 4

CHAPTER 5

DISCUSSION OF RESULTS AND CONCLUSIONS

Statistical Method employed

The results have been treated statistically. The analysis shows that none of the equations give coefficients which agree for all the records. To avoid the mass of figures necessary to show the inconsistency from a rigorous statistical view point a simplified demonstration of the lack of agreement is given here.

Confidence Intervals

When any experimental observation is made it has a certain inherent error depending upon the precision of the apparatus and care taken in making the reading. Similarly when a figure, a coefficient for example, is derived statistically from a set of readings the figure has an error associated with it. The exact value of this error is difficult to assess. However, it is a simple matter to find the standard deviation of the figure, this depends upon the number and spread of the readings.

From the standard deviation a confidence interval can be computed. The confidence interval is a range about an estimate of a parameter within which one can be sure, to a certain probability, that the true value of the parameter lies. e.g. If an estimate, A' of a parameter, A , has a '95% confidence interval' extending from A_1 to A_2 , it can be said with a certainty of 95% that A lies between A_1 and A_2 .

Applications

(1) If an estimate has a confidence interval not including a

number, N, it can be said that the estimate is not an estimate of N with certainty or confidence to the appropriate probability. If this is the case the estimate is said to be significantly different from N.

(2) If two estimates have confidence intervals not including each other they are said to be significantly different.

Computation of Confidence Intervals

The width of a confidence interval depends upon the level of significance required. The greater the precision desired the wider the confidence interval must be.

For normally distributed data the confidence intervals for different probabilities are given below.

Confidence Interval	Probability %
Estimate ± 1 standard deviation	68.3
" ± 2 " "	95.5
" ± 3 " "	99.73
" ± 4 " "	99.99

Discussion of Results

The summary of the data given in Table 1 is self explanatory. The correlation coefficients are those given by the computer. It was expected from graphical analyses and study of records that there would be a high correlation between the potential gradient, F, and the collector current, I, and also between the wind speed, W, and I. Table 1 shows this generally to be the case except for W - I in record 4.

Record 4 is that of least range in wind speed, only 2.1 m/sec

between minimum and maximum. With such a small range wind effects cannot be expected to ^{be} very apparent, except with very many observations. Unfortunately record 4 was too short for wind effects to be detected.

The few significant correlations between F and W were entirely unexpected. It is just possible that this effect could be due to space charge blowing along the valley from the Consett Iron Works. The town of Consett lies WNW of Durham and the two are linked by a valley. The valley may be narrow enough to have held the space charge cloud together while it drifted with the West wind towards Durham. There would be correlation between W and F if the process was similar to that observed on the North German coast during off sea winds. This effect in Germany was described by MUHLEISEN (1963) at the Montreux Conference. A very strong correlation between wind speed and potential gradient was observed due to space charge being blown off the sea. It must be stated that the conditions in Durham for this effect are very poor compared with the coastal observations. In the author's opinion this explanation is ^{robust} ~~impossible~~ but the only one of which he is aware.

The coefficients of equation (1) :-

$$I = a + bF + cW + dWF$$

are given in Table 2. If an equation of this form is to give a useful representation of the results then the estimates of the coefficients must be the same, subject to experimental error. Even a brief glance at Table 2 is sufficient to show that a number of the coefficients are zero. This signifies that the variable in question makes no significant contribution to fitting the data at the 0.1% level. It is clear then that there are great

differences among the ten equations represented in Table 2. These great differences make it evident that an equation of the form of equation (1) will not represent the data.

Table 3 gives the constants in the equation :-

$$I = kFPWq \dots\dots\dots(11)$$

Examination of the table shows that p is about unity and q is about a half. This would give a nice simple equation. To test whether or not the values of p are estimates of unity we assume that p has a normal distribution with mean unity and standard deviation as given by the computer. (The computer gives the standard deviation of each estimate it calculates). For a normal population the probability that a value will deviate from the mean by 3 standard deviations by chance alone is 0.3%.

Fig (5.1) shows the values of p with their deviations. If they were estimates of unity then each spread would include unity. Such a spread is called a confidence interval and has a probability assigned to it. e.g. given the 99.7% confidence interval one can be sure that on average an estimate of a quantity will lie in the interval of 99.7% of trials. The 99.7% confidence intervals are shown in Fig. (5.1).

It can be seen that only five out of the ten estimates include unity in their confidence interval. Thus showing that the apparent similarity is not real.

It can also be seen that the confidence intervals are not consistent. They do not all include each other, therefore it can be concluded that all the data cannot be accurately represented ^{by} any one of equations of type (11).

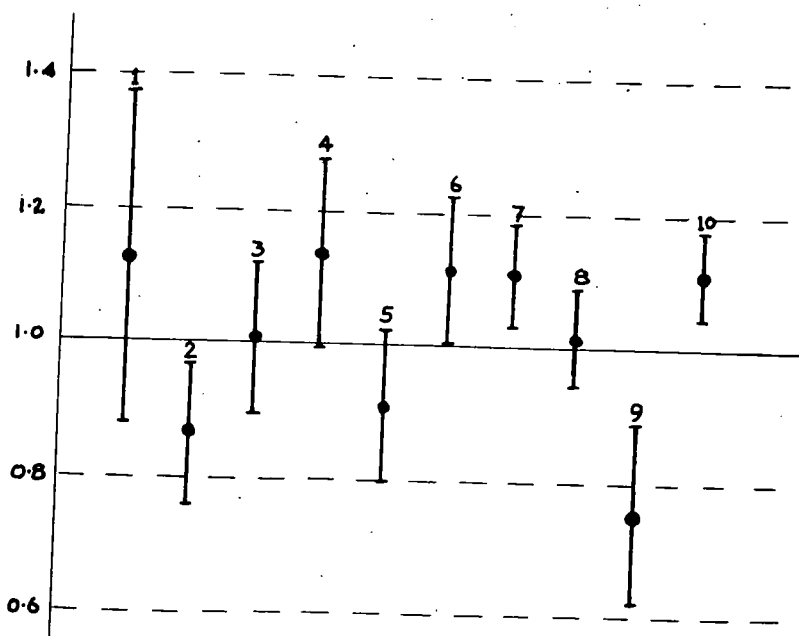

99.7% Confidence interval for power
of F in equation ii.

Fig 5.1

Fig. (5.2) showing the confidence intervals for the power of W shows a very similar picture. The tendency to assume that the values obtained are estimates of 0.5 is not valid. The only estimate which is consistent with all others is that of No.4 whose confidence interval includes all the others.

The great width of the confidence interval of No.4 shows that the estimate is subject to great inaccuracy. (The contribution of wind in record 4 has been discussed previously in relation to the non significant correlation coefficient)

The same considerations apply here.

Inspection of Table 3 shows that the estimates of k range over a whole order of magnitude. This range is not as bad as it appears if one examines the original regression coefficient, k' , in equation (ia) before the transformation to equation (ii) was made. Although even here the minimum and maximum differ by a factor of nearly four.

From Table 3 it will be noticed that records 2 and 9 are very much different from all the others. However, even if they are omitted the differences mentioned above are still highly significant although not so striking. The differences between records 2 and 9 and all the others is apparent in every representation of the data. Examination of meteorological elements shows no difference in conditions which would render records 2 and 9 to be exceptional. Both records are sufficiently long to smooth any freak effects which may have occurred for a short time. The author is unable to offer any plausible explanation for the discrepancy.

It has been mentioned that equation (i) and (ii) were fitted with physical considerations in mind. Equations (iii) and (v) represent

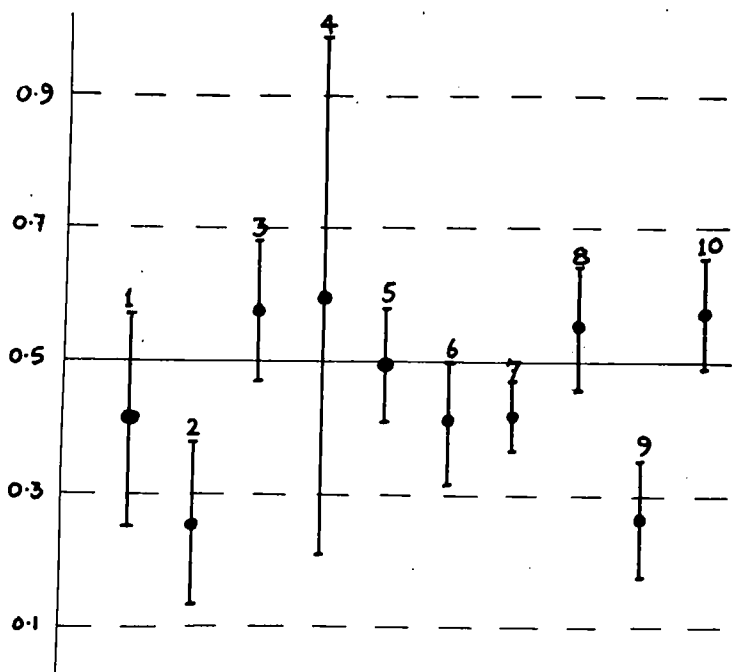

99.7% Confidence interval for power
of W in equation ii.

Fig. 5.2

the simple approach of fitting straightforward regression equations. Fig. (5.3), (5.4), (5.5) show the constants a, b, c , of equation (111) with their 99.7% confidence interval.

Reference to Figs. (5.3), (5.4), and (5.5) shows that the values of the coefficients are not consistent with each other. The values and confidence intervals for the coefficients of equation (iv) are shown in Figs. (5.6) and (5.7).

Fig. (5.6) shows that the estimates of the constant a' in equation (iv) are nearly consistent (i.e. even though the chance of them all being estimates of the same value is less than 0.3%, they are at least the most consistent yet considered). It is to be expected that equation (iv) should appear to be consistent. Since it fits only one variable the deviations from the best straight line will be large, yielding a large standard deviation and so a wide confidence interval.

Fig. (5.7) shows that the estimates of b' are not consistent with the hypothesis that they are estimates of a single value of b' .

Possible value of fitting other equations

Four equations have been fitted to the data and none of these are consistent between records. i.e. The equation of a particular type which gives best fit to the data of one record does not give a fit to the data of another. Therefore it can be said that the investigation has failed to find a way of relating the radio-active collector current to the potential gradient and wind speed in such a way that an accurate estimate of potential gradient can be found from the other two.

It may be said that only four equations have been tried and

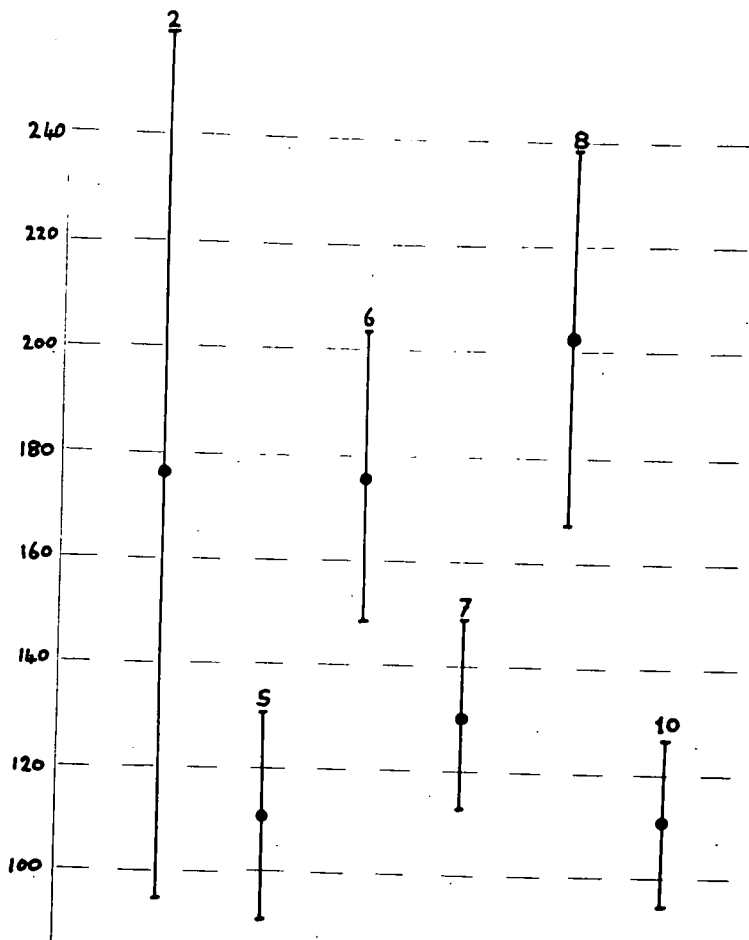

99.7% Confidence interval for a
in equation iii.

Fig 5.3

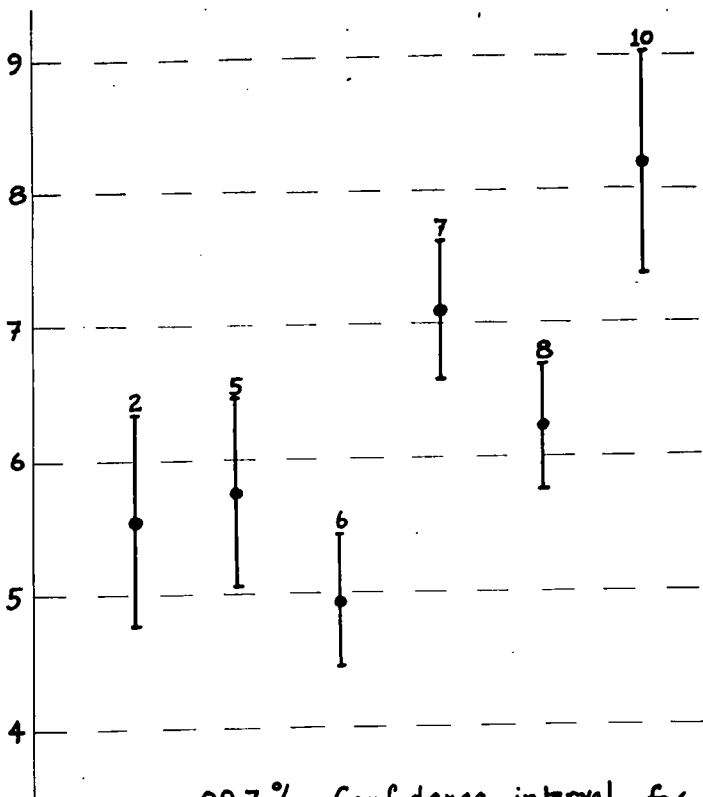

99.7% Confidence interval for b
in equation iii.

Fig 5.4

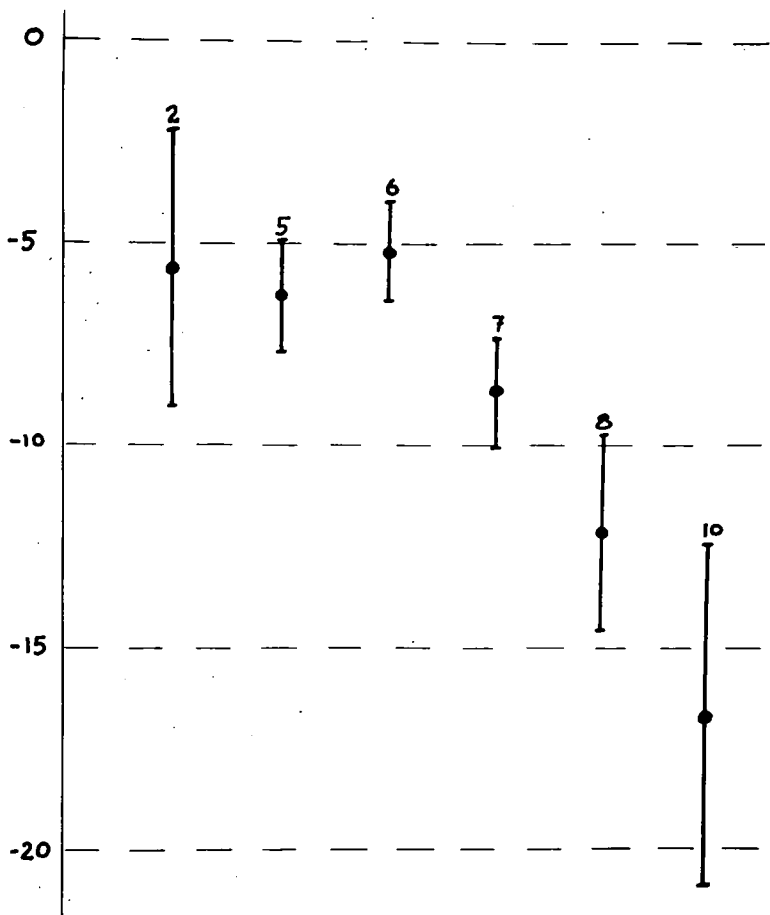

99.7% Confidence interval for c
in equation iii.

Fig. 5.5

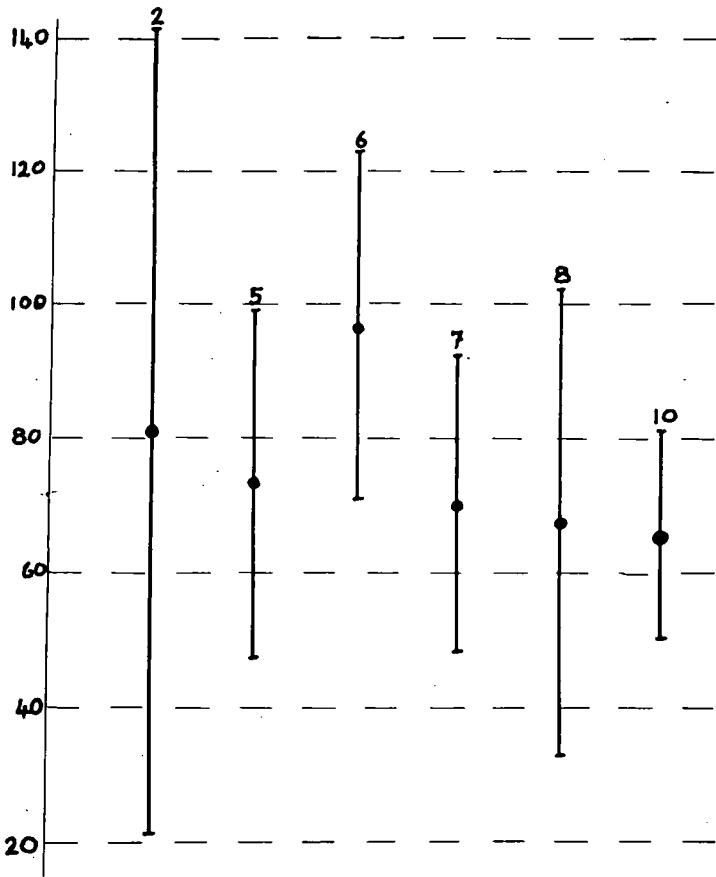

99.7% Confidence interval for a'
in equation iv.

Fig. 5.6

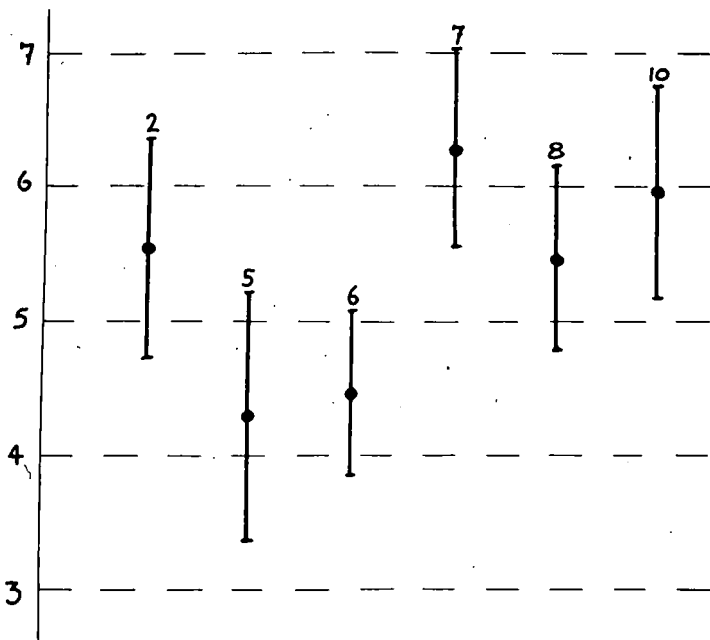

99.7% Confidence interval for b' in equation iv.

Fig 5.7

there may well be an equation which, although not tried, would fit the data of all records without having to change the coefficients. Fig. (5.8) shows very clearly that this is not the case. The crosses and dots represent data taken from two different records with the same wind direction. Both sets show clearly that individually some curve will give a good fit to the data. Equally clearly they show that one equation will not give a good representation of all the data together.

Advantage of wind measurement

BENT (1955) and SCHAEFER (1955) got an estimate of potential gradient from only the collector current. The high positive correlations obtained in this investigation confirm this. The correlations between wind and collector current generally obtained show that wind has an influence. Since none of the equations found gives a useable relation for accurate determination of potential gradient it must be asked "How good the equations are as estimators?".

In order to get an estimate of the accuracy of the predictions of potential gradient for each equation the following procedure was adopted. A number of sets of values of F , I and W were taken from the record. The estimate of F was calculated for each equation from the values of I and W . The root mean square of the values of $(F - \text{estimated } F)$ was taken as an estimate of the error. It was found that ten randomly selected sets of data would give an estimate of the error reliable to about one or two parts in ten. This was regarded as being sufficiently accurate for an estimate of an estimate

Since equation (1) was not even consistent in its form, there being different terms omitted on different occasions, it was not

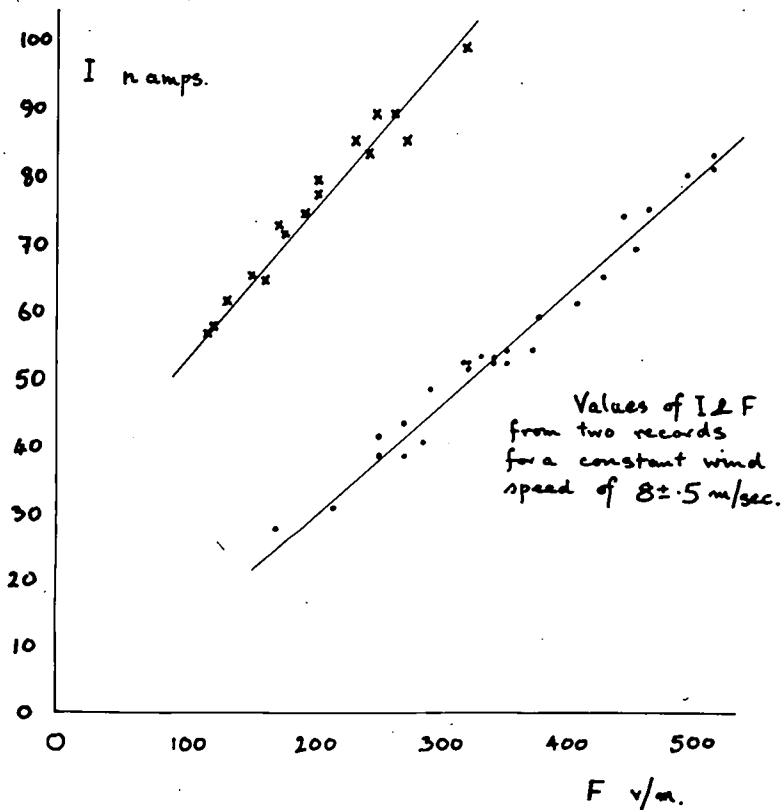

Fig 58

RECORD	2	5	6	7	8	10	mean
Equation 11b	9	10	9	5	6	13	8.67
Equation 11i	11	8	7	8	6	8	8.00
Equation 1v	9	10	6	11	8	26	11.67

Table 5

considered in this analysis.

Equation (11a) was re-arranged to give F in terms of I and W :-

$$\log I = k' + p \log F + q \log W \dots\dots\dots (11a)$$

$$\therefore \log F = -\frac{k'}{p} + \frac{1}{p} \log I - \frac{q}{p} \log W$$

$$\text{Hence } F = e^{-k'/p} I^{1/p} W^{-q/p}$$

$$\text{Or } F = A I^B / W^C \dots\dots\dots (11b)$$

The values of these estimates of error in percentages are shown in Table 5.

The table shows that there is no appreciable difference in accuracy between the estimates from different equations except for record 10. Hence in all but record 10 nothing has really been gained by the measurement of wind speed.

In the cases where the less general equation (11i) excluding wind gives a more accurate result than equation (11) including wind, the danger of the use of small samples is in evidence. If the error of these figures, up to 20%, is recalled it can be seen that there is no real paradox.

The difference in accuracy between equations (1v) and the others in record 10 is due to a phenomena observed by CHAPMAN (1956). In conditions of low field and high winds Chapman observed very great fluctuations over short periods. Because of the great effect of wind in these conditions, those of record 10, a large gain in accuracy is made if wind is taken into account. The mention of "low field" by Chapman is to ensure that there is not saturation where

wind changes have little or no effect.

Statement of Conclusions

As far as this investigation can show it is not possible to get an accurate measure of potential gradient from the records of radio-active collector current and wind speed.

An equation derived from simultaneous reading of I, F and W gives an error of about 8% on average for an estimate of F from I and W taken during the record. If such an equation were used to estimate F beyond the period of the record an accuracy of 8% would be the best one could hope for.

However, on the occasions where records were taken soon after one another (e.g. records 5 and 6, and 7 and 8), there is significant differences in the coefficients of the equations. Thus it can be seen that although an equation may give estimates to an accuracy of 8% initially the error rises very quickly due, possibly, to fluctuations in meteorological parameters not measured. Tables 2, 3 and 4 show without doubt that no one equation is suitable for any length of time.

The only use of the earthed radio-active collector is to give an idea of the potential gradient as used by BENT (1955) and SCHAEFER (1955). The accuracy gained by measurement of wind is on average 3.7%. This, however, leaves the residual error of 8%. Thus it can be seen that the trouble of measuring wind speed does not yield a worthwhile dividend in accuracy of estimation. An accuracy of 11.7% being not a great deal ^{worse} ~~better~~ than one of 8% if only an estimate is required.

The error of 8% should not be taken as an indication of the accuracy of potential gradient. This error is that taken over a

short period when the best fit to conditions prevailing at that time only was made.

The constants in the equations were all found to be inconsistent with each other. In view of this it is not possible to make any conclusions as to the effect of different wind directions. Although the tables and figures show differences between the West and non West (Records 1 and 10) results, these differences are no greater than those within the West results alone.

Possible reasons for inconsistency

In view of the simple way that it is possible, qualitatively at least, to describe the action of the earthed radio-active collector it is strange that the results should be so erratic.

Short-term fluctuations

The cause of rapid fluctuations in collector current is rapid changes in potential gradient or wind speed. The rapid changes in wind speed are most likely in fine weather to be predominant. It is a common experience that wind speed quite close to the ground is extremely variable. The gusts and eddies in the air moving past the collector will interfere with the space charge there all the time. These changes in space charge affect the current. The duration of the changes is very small. This is the crux of the matter. For the reasons described the wind speed galvanometer had a long (20 sec) period. Hence as well as smoothing the peaks of the generated AC it will have smoothed the small period gusts and eddies. The wind speed measured was an average as were the others. It may be that an average is not good enough while a system with a faster response time may be.

To achieve a quicker response time is not quite as easy as it may appear. It could not be done with the present system. The wind would have to be measured with a non-mechanical anemometer (e.g. hot wire or thermistor). With all records now having a period of 1 or 2 secs. photographic recording becomes difficult for the trace will be very faint because of its rapid movement. The camera would have to be speeded up to avoid the rapid deflections producing a wide blur on the paper.

The speeding up would facilitate the obtaining of data rapidly but would result in either using a great deal of photographic paper or sampling over shorter times.

Other sources of variation are hard to find. Temperature and pressure can have only a marginal effect on the range of the radiation particles. No natural atmospheric change in temperature or pressure could have any appreciable effect on the mobility of the ions. High relative humidity would not cause any difference other than marginal in the range of the emitted particles.

The range is of importance because ~~ions form~~ ion pairs formed a long way from the collector will have less chance of reaching it, and contributing to the current, than those formed close to the collector which do not have to suffer the effect of wind for so long.

If some meteorological effect allowed the range to increase more ion pairs would be blown away before they could separate and migrate as part of the current.

Effect of surface contamination on day to day variations

It is probable that the surface of the radio-active laminae may become covered with foreign matter owing to dew and rain leaving

deposits on their eventual evaporation. Such deposits would absorb radiation leaving the laminae and so would reduce the number of ion-pairs produced in the air around the collector. Now since the accumulation of deposits would be variable it is to be expected that the characteristics of the collector current will vary from time to time according to the amount of deposit present.

It is of interest to note that this variation in effective activity would not affect the operation of an equalising collector. Provided that some effective activity remained to perform the equalising, accumulation of deposits would be of no consequence.

ACKNOWLEDGEMENTS

The author wishes to express his sincere thanks to all those who have helped in the course of this work. Particularly to Dr. J. A. Chalmers, his supervisor, for his constant advice and support at all stages of the work.

Thanks are due to Professor G. D. Rochester for making the facilities available and to D.S.I.R. for a maintenance grant during the period 1961 to 1963.

The author would like to thank the technical staff of the Physics department and his fellow research students who were always willing to give advice and assistance.

He is also indebted to his wife for her patience and help in the typing of this thesis.

Finally the author would like to take this opportunity of expressing his thanks to the AVCO Corporation U.S.A. for making possible his attendance at the Montreux conference where he was able to deepen his understanding of the field of Atmospheric Electricity.

REFERENCES

- BENT, A.E. 1955 "Variations in Atmospheric Electricity at Mount Washington". Mount Washington Obsy. News Bull. 27.pp.1-8.
- COLLIN H.L. 1962 "Sign discrimination in Field Mills" J. Atmosph. Terr. Phys. 24.pp.743-745.
- COLLIN H.L. 1963 M.Sc. Thesis, Durham.
- COLLIN H.L., RAISBECK I.A. and CHALMERS J.A. 1963 To be published.
- CHALMERS J.A. 1952 "The Relation between point discharge current and field" J. Atmosph. Terr. Phys. 2.pp. 292-300.
- CHALMERS J.A. 1952a "Point discharge currents" J. Atmosph. Terr. Phys. 2.pp.301-305.
- CHALMERS J.A. 1957 "Atmospheric Electricity". Pergamon Press.
- CHALMERS J.A. 1957a "Point discharge current potential gradient and wind-speed". J. Atmosph. Terr. Phys. 11.pp.301-302.
- CHALMERS J.A. 1962 "The relation of point-discharge current to potential difference and wind-speed". J. Atmosph. Terr. Phys. 24.pp.339-344.
- CHAPMAN S. 1956 "Electrostatic field measurements, corona discharge and thunder clouds". Report C.A.L. 68. (Buffalo, N.Y.:Cornell Aeronautical Laboratory).
- DOLEZALEK H. 1960 "Zur Methodik luftelektrischer Messungen VI: Das Ersatzschaltbild für den radioaktiven Kollektor zur Messung der luftelektrischen Feldstärke" Gerlands Beiträge zur Geophysik 69(2). pp. 87-94.
- ECCLES D. 1961 Private Communication.
- HANNFELD J. 1932 "Untersuchungen über die elektrische Raumladung und das elektrische Feld am Boden" Ziet. Geophys. 8.pp.89-106.

- IMANIATOV I.M. 1962 "Instruments and Methods for measuring Atmospheric Electricity" (Translation A.V.C.O. U.S.A.)
- ISRAEL H. 1939 "Reichsanstalt für Wetterdienst" Wissenschaftliche Abhandlungen 5:12
- ISRAEL H. 1963 Proceedings of third International Conference in Atmospheric Physics. To be published.
- KELVIN Lord, 1859 Proc. Lit. Phil. Soc. Manchester and "Papers on Electricity and Magnetism". pp.200-203.
- KOBAYASHI J. and KYOZUKA M. 1962 "On the specially designed Radiosondes used in Japan during the world meteorological intervals as a programme of the International Geophysical Year". Part 2 Balloon-borne Electrometer and its applications". Geophys. Mag. 31, No.1. pp.195-236.
- MAPLESON W.W. and WHITLOCK W.S. 1955 "Apparatus for the accurate and continuous measurement of the earth's electric field" J.Atmosph. Terr. Phys. 7.pp.61-72.
- MILNER J.W. 1960 Ph.D. Thesis. Durham.
- MUHLEISEN R. 1951 "Zur Methodik der luftelektrischer Potentialmessung: Einfluss des Windes bei radioaktiven Kollektoren." Z. Naturf. 6.pp. 667-671.
- MUHLEISEN R. 1963 Proceedings of third International Conference in Atmospheric Physics. To be published.
- RAISBECK I.A. 1963 M.Sc. Thesis, Durham.
- SCHAEFER V.J. 1955 "Atmospheric Electricity associated with Jet Streams". Wentworth Conference. pp.59-66.
- SMIKNOV D. 1904 "Ein rasch wirkender Wasserkollektor". Physikalische Zeit. 5(19) pp.597-599.
- WAGNER R. 1955 "Zur Messung des luftelektrischer Potentialgefalles mittels Kollektoren". Arch. Met. Geoph. Bio. Series A, 8.pp.427-464.
- WICHMAN H. 1953 "Die Messung des luftelektrischen Feldes mit radioaktiven Potentialsonden". Arch. Met. Geoph. Bio. Series A, 5.pp.86-99.

